

SECTION 2 HYDRAULIC SYSTEM

Group 1	Hydraulic circuit	2-1
Group 2	Hydraulic component testing	2-2
Group 3	Self level valve	2-8
Group 4	Auxiliary pump	2-14
Group 5	Main pump	2-20
Group 6	Travel motor	2-41
Group 7	Main control valve	2-51
Group 8	Boom and bucket cylinder	2-58

SECTION 2 HYDRAULIC SYSTEM

GROUP 1 HYDRAULIC CIRCUIT

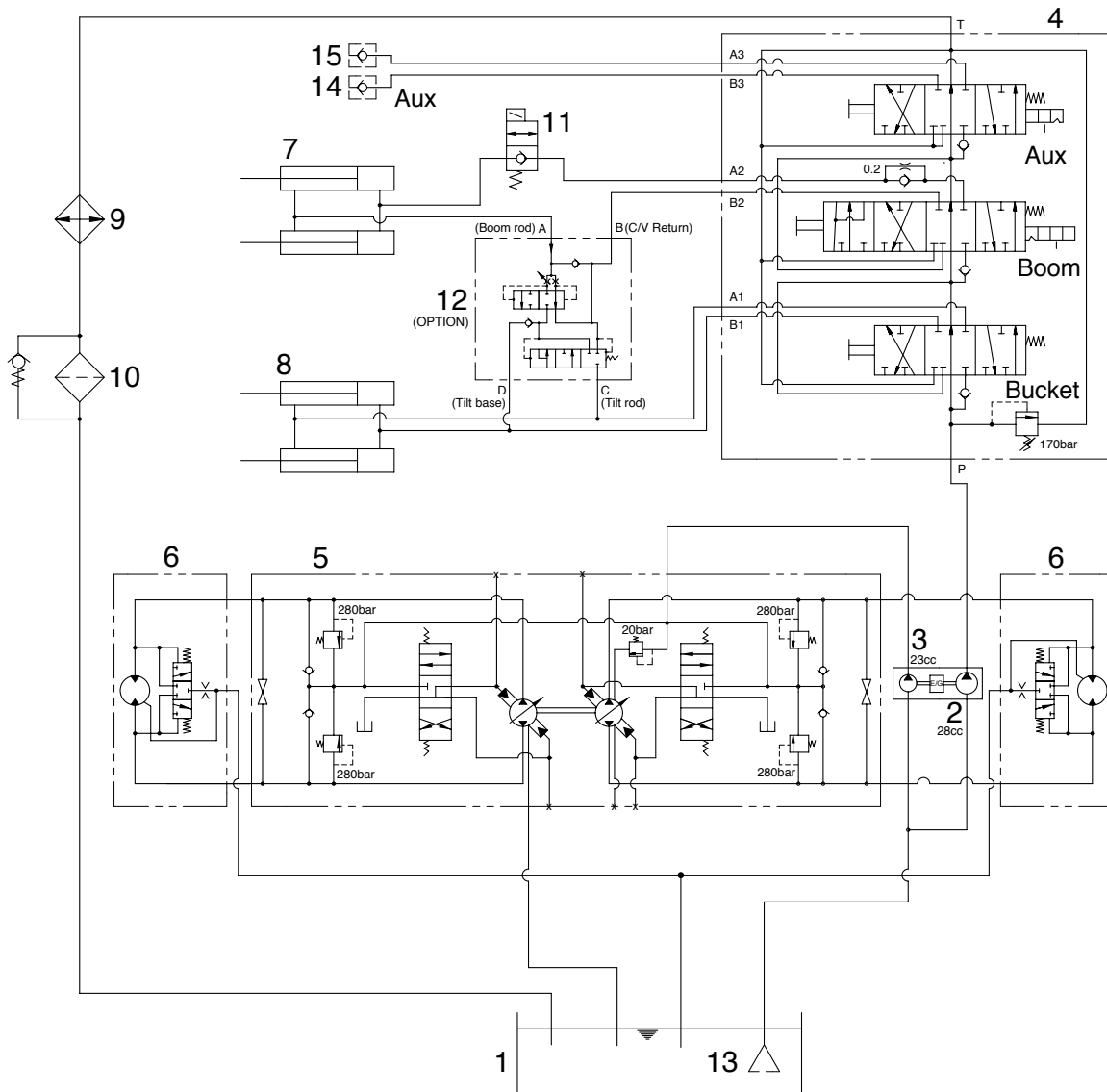

- | | | | | | |
|---|----------------------|----|---------------|----|-----------------------|
| 1 | Oil tank | 6 | Travel motor | 11 | Solenoid valve |
| 2 | Gear pump(Auxiliary) | 7 | Lift cylinder | 12 | Self level valve |
| 3 | Gear pump(Charge) | 8 | Tilt cylinder | 13 | Suction strainer |
| 4 | Main control valve | 9 | Oil cooler | 14 | Quick coupler(Female) |
| 5 | Main pump | 10 | Oil filter | 15 | Quick coupler(Male) |