

# SECTION 1 HYDRAULIC SYSTEM



<b>Hydraulic Circuit</b>	<b>1.1</b>
Layout .....	pg. 1~2
Schematic .....	pg. 1~3
Specifications .....	pg. 1~4
Maintenance Schedule .....	pg. 1~4
<b>Gear Pump</b>	<b>1.2</b>
General Information .....	pg. 1~5
Replacing the Gear Pump .....	pg. 1~6
Gear Pump Disassembly .....	pg. 1-7 ~ 10
Gear Pump Reassembly .....	pg. 1-11 ~ 13
<b>Control Valve</b>	<b>1.3</b>
Testing / Adjusting the Relief Valve .....	pg. 1-14 ~ 15
Control Valve Replacement .....	pg. 1-15 ~ 16
Exploded Illustration Diagram .....	pg. 1-17 ~ 18
Control Valve Disassembly / Repair(175) .....	pg. 1-19 ~ 24
Control Valve Dissassembly/Repair(1700) .....	pg. 1-25~28
<b>Hydraulic Cylinders</b>	<b>1.4</b>
General Information .....	pg. 1~29
Testing Piston Seals .....	pg. 1~30
Lift Cylinder Replacement .....	pg. 1~31
Tilt Cylinder Replacement .....	pg. 1~32
Cylinder Disassembly .....	pg. 1-33 ~ 34
Cylinder Inspection .....	pg. 1-35
Cylinder Assembly .....	pg. 1-35 ~ 36
<b>Hydraulic Oil Filter</b>	<b>1.5</b>
General Information .....	pg. 1~37
Filter Replacement .....	pg. 1~37
<b>Hydraulic Oil Cooler</b>	<b>1.6</b>
General Information .....	pg. 1~38
Oil Cooler Replacement .....	pg. 1~38
<b>Hydraulic Oil Reservoir</b>	<b>1.7</b>
General Information .....	pg. 1~39
Checking the Oil Level .....	pg. 1~39
Adding Oil .....	pg. 1~39
Servicing the Reservoir .....	pg. 1~40
<b>Trouble Shooting</b>	<b>1.8</b>
Trouble Shooting Chart .....	pg. 1-41 ~ 42
<b>Torque Chart</b>	<b>1.9</b>
Torque Chart .....	pg. 1~42
<b>Conversion Charts</b>	<b>1.10</b>
Conversion Charts .....	pg. 1-43 ~ 1-45

# 1

## HYDRAULIC LAYOUT 1.1

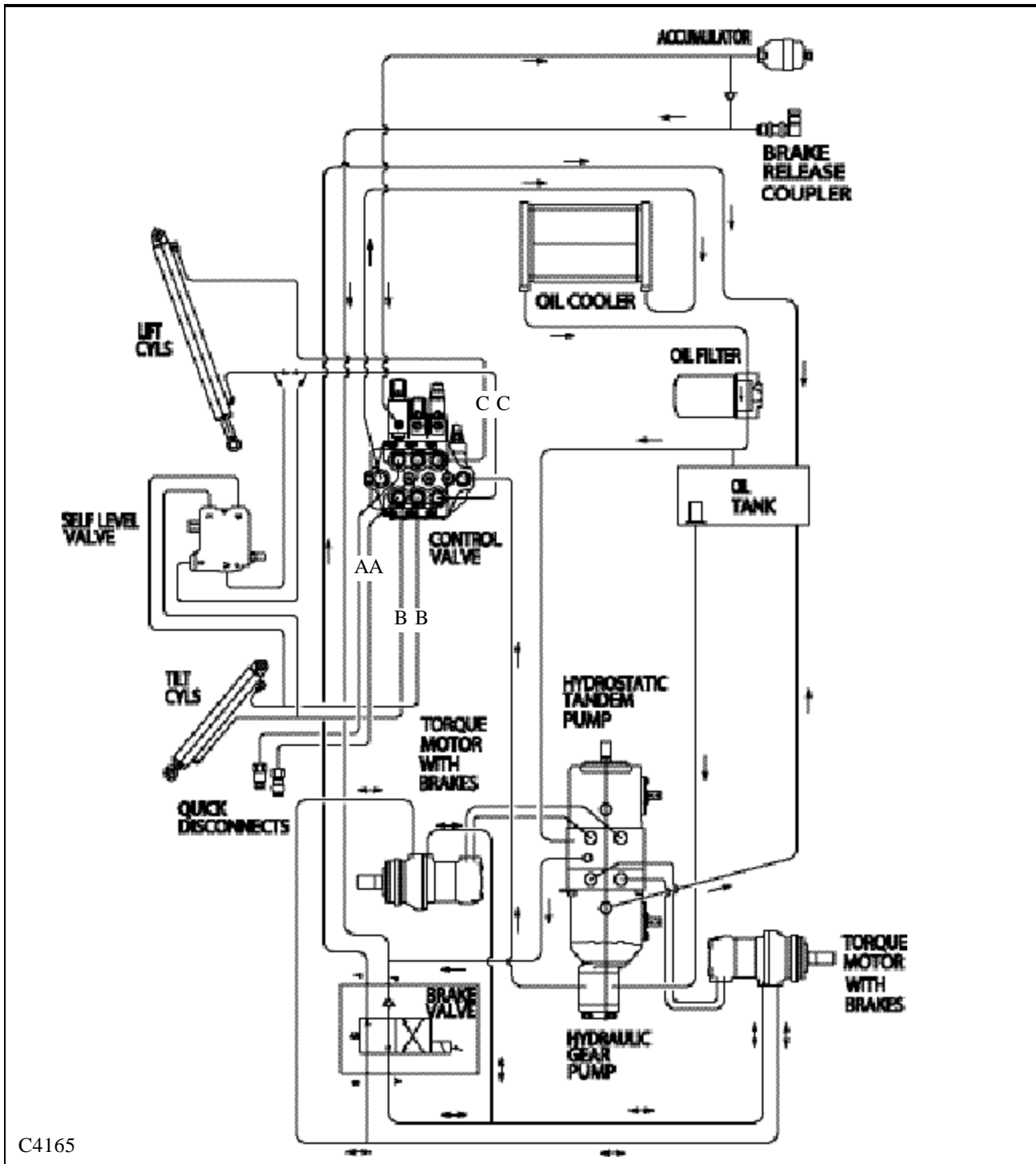

C4165

- A Auxiliary Circuit
- B Tilt Circuit
- C Lift Circuit

NOTE: Foot pedal control operated machine illustrated. Items (A3 / B3) are reversed for hand control operated machines.

Hydraulic fluid comes out the port closest to the spool end of the valve when the spool is pushed in. Hydraulic fluid received at the fixed end of the cylinder pushes it out. When the hydraulic cylinder receives fluid at the ram (rod) end, it retracts.

# HYDRAULIC SCHEMATIC 1.1

1

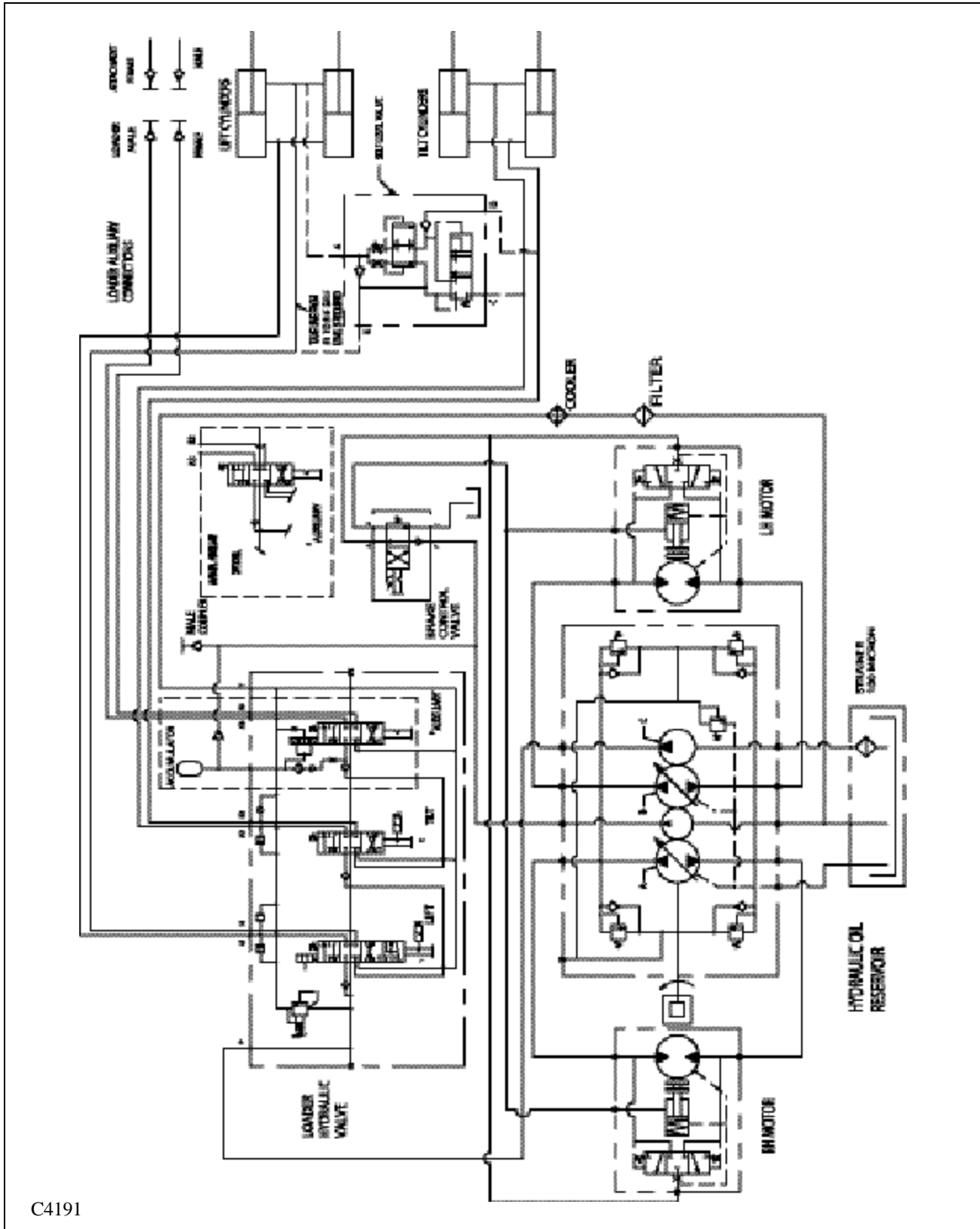

C4191

# 1

## – SPECIFICATIONS & MAINTENANCE 1.1 –

### Hydraulic Specifications

Pump Type	Gear, 1.37 cu. in. (22.4cc)
Pump Brand	Sauer Sundstrand
Pump Capacity	16.6 GPM (62.8 LPM)
Rated Speed	2800 RPM
Control Valve	Series Type
Main Relief Pressure	2400 PSI (165.5 Bar) @ Zero Flow
Reservoir Capacity	14.8 US Gallons (56 Liters)
Fluid Type	10W30 API SJ Oil
Reservoir Filtration	100 Micron
System Filtration	5 Micron
Oil Cooler	650 BTU
Lift Cylinders (STD)	(2) 2.5" Bore Diameter
Lift Cylinder Rods (STD)	1.5" Diameter
Tilt Cylinders	(2) 2 1/2" Bore Diameter
Tilt Cylinder Rods	1.5" Diameter
Lift Cycle Cyl. +/- 1.5 seconds (Up / Down) T175	5.50 / 3.56
Lift Cycle Cyl. +/- 1.5 seconds (Up / Down) 1700	4.6 / 3.0
Tilt Cycle +/- 1.5 seconds (Up / Down) T175	1.84 / 2.61
Tilt Cycle +/- 1.5 seconds (Up / Down) 1700	1.73 / 2.28
Lift & Tilt Cycle Cyl., +/- 1.5 seconds (Up & Out)	5.25
Lift & Tilt Cycle Cyl., +/- 1.5 seconds (Down & In)	4.55
Allowable Drop, Measured at the Cylinder Rod, Engine Off, @ Rated Capacity and Operating Temperature	1.5" (38mm) / 3 Minutes

### Maintenance Schedule . . . . . First (HRS) . . . . Every (HRS)

Oil level check	8	8
Oil filter change	50	150
Oil cooler clean	8	8
General system check ( leaks etc. )	8	8
Cylinders, lubricate	8	8
Control valve relief filter	500	1000
Reservoir filters change	1000	1000
Hydraulic oil change	1000	1000

# GENERAL INFORMATION 1.2

Refer to figure C2018 on page 1-2.

Oil is drawn from the hydraulic oil reservoir through a 100 micron element. From there it travels to the main hydraulic pump.

- The hydraulic pump is a gear type which is driven by a shaft and coupler through the hydrostatic drive pump at engine speed. The oil then flows from the gear pump to the hydraulic control valve.
- The hydraulic control valve is equipped with an adjustable relief valve which is adjusted to 2400 PSI (165.5 Bar). The control valve is a series type with 3 spools (banks). The various spools activate the boom, bucket and auxiliary hydraulic functions.

When the spools are in neutral, oil flows from the hydraulic gear pump, through the control valve and returns to the hydraulic cooler, to the 5 micron hydraulic filter. From the hydraulic filter, the fluid flows to charge the tandem hydrostatic pump and pressurize the hydraulic brake release system and then back to the hydraulic reservoir. As a spool is moved, oil is directed to one of the valve ports and oil flows out to operate a function. The return oil coming back from this operation is ported to the next valve section which allows operation of more than 1 function at the same time. This is a series type valve function.

Each spool end contains a centering spring which returns the spool to neutral when the foot pedal, or control handle, is released.

- The boom section, on foot control operated loaders, has a detent mechanism to hold the spool in the float position. The auxiliary section is operated by foot pedal operation, or may have an optional electrical solenoid operated control, and may be engaged momentarily by the control lever mounted switch, forward or reverse, or by engaging the dash mounted toggle switch for constant power in the forward direction only.

The system relief valve operates when ever a hydraulic function has been restricted or overloaded (fig. C3746). To protect against excessive pressure build up, the relief valve opens and allows oil to return to the return outlet. The system relief valve is adjustable, and is preset at 2400 PSI. (165.5 Bar)

- Load check valves are located between the ports of each spool circuit. The function of the load check valve is to hold the boom arms or bucket in position during initial spool movement (fig. C3717).

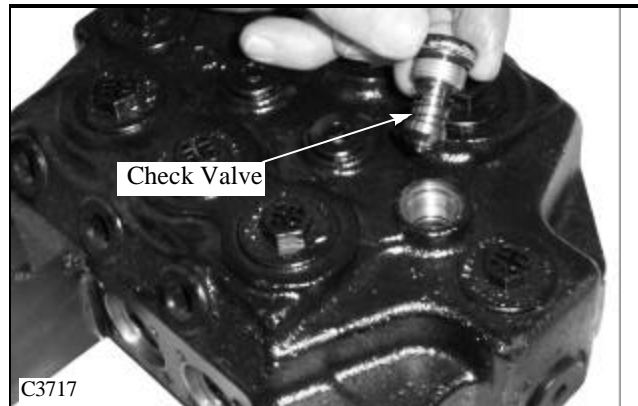
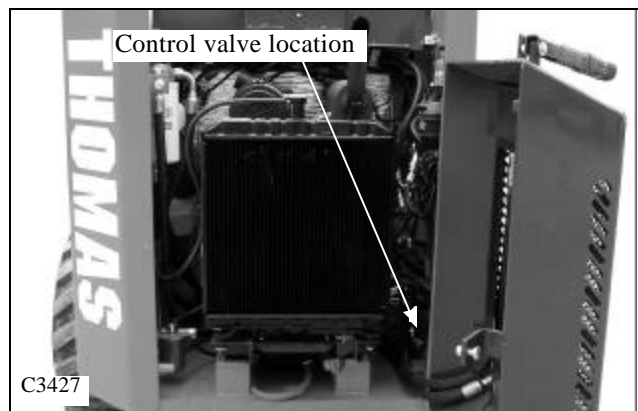
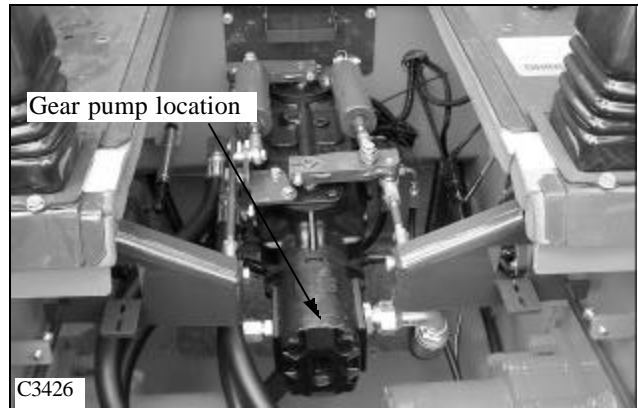

# GEAR PUMP 1.2

# 1

## Replacement

Start the gear pump removal procedure by removing any attachment, raising the boom arms and engaging the boom support pins. Shut off the engine.



### WARNING

**To prevent personal injury do not work under the boom arms without the boom supports engaged.**

- 1 Remove the seat and hydrostatic shield.
- 2 Attach a vacuum system to the hydraulic oil reservoir filler location. ( fig. C3428 ) Or drain the oil reservoir. Seal the threads on the drain plug, if removed, with teflon tape or a liquid form of pipe sealant before re - installing.
- 3 Disconnect the hydraulic hoses from the gear pump. ( fig. C3429 ) Remove the pump fittings. Cap all open hoses to prevent contamination. After capping ends you may unhook vacuum system from oil reservoir.
- 4 Remove the 2 bolts holding the gear pump to the hydrostatic tandem section. ( fig. C3430) Remove the gear pump.
- 5 Replace gear pump in reverse order.

### IMPORTANT

**If gear pump replacement is being done because of failure, the hydraulic system and oil should be checked for contamination.**

- 6 If the hydraulic system has been contaminated by pump or other failure you must follow the cleaning procedure outlined in section 2.7.



### WARNING

**Use caution when dealing with hydraulic fluid under pressure. Escaping fluid under pressure can penetrate the skin and cause serious injury.**

- 7 Start the engine and check for leaks. Do not use your hands to find leaks.
- 8 Check the fluid level in the hydraulic oil reservoir and replenish as required. (fig. C3431)

### IMPORTANT

**When making repairs to the hydraulic system, keep the work area and parts clean. Use caps and plugs on all open lines and ports.**

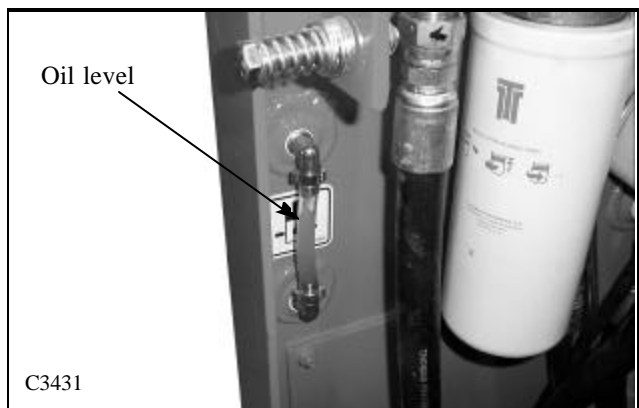
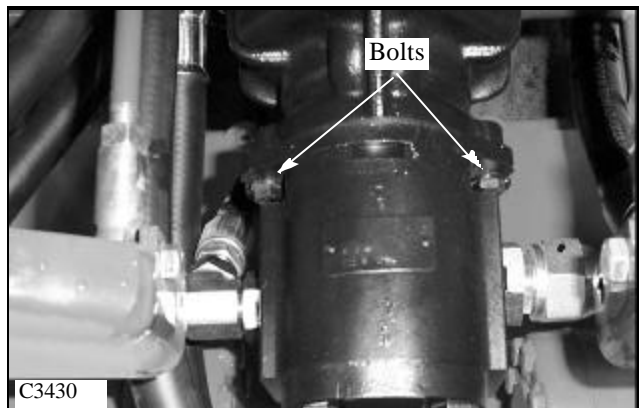
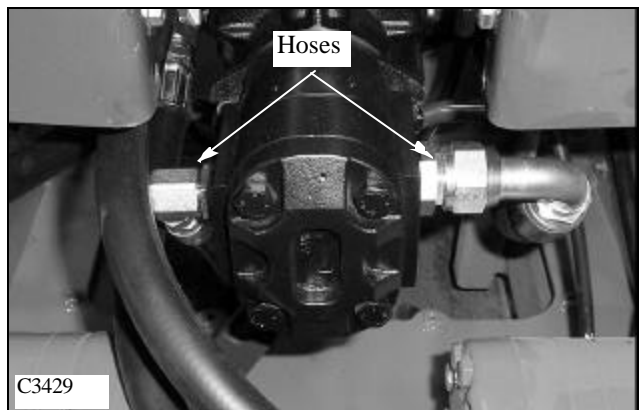
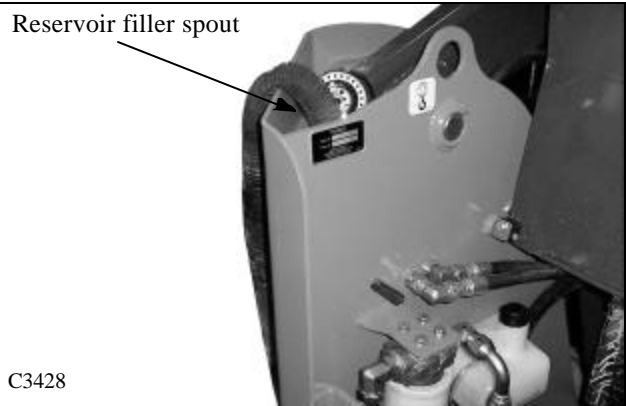

# GEAR PUMP 1.2

## Disassembly

1

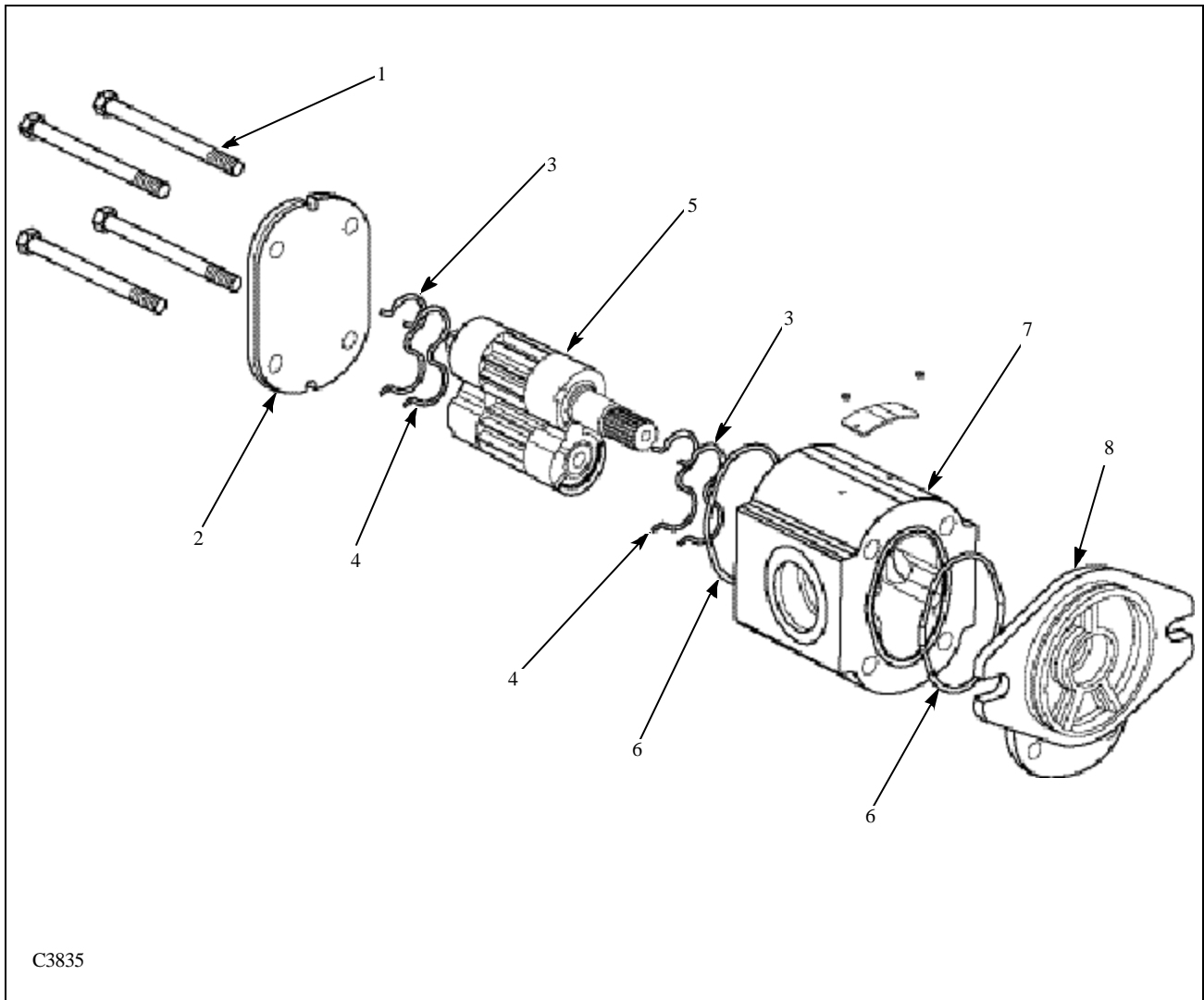

1. Screws
2. Rear Cover
3. Backing Strip
4. Moulded Seal
5. Drive Gear
6. O-Ring Seal
7. Body
8. Front Plate

# GEAR PUMP 1.2

## 1

### Disassembly (continued)

#### 1. General

The following is a detailed procedure for disassembly and assembly of the SP2.5 pumps. Prior to proceeding it may be necessary to prepare some subassemblies separately. The details for preparing each subassembly are given in the following section, as well as some general recommendations.

#### 2. Cleanliness

Cleanliness is the primary factor for reliable pump performance. Wash the outside of the pump thoroughly before disassembly and all pieces prior to assembly. Cleaning parts with clean shop solvent and air drying is usually adequate.

#### 3. Lubrication Of Moving Parts

During assembly, it is imperative to provide lubrication with clean hydraulic oil to all the running parts of the pump. It is also necessary to coat the seals with grease. The absence of lubrication during assembly can cause the unit to seize after a few minutes of running.

#### 4. Care Of Surface Treatment

Be careful when handling all the internal surfaces, especially bearings, gears, and body faces. Do not touch or score them with metal tools or cutting edges.

#### 5. Marking The Parts

Mark the parts before completely disassembling a pump. The marks allow components to be reassembled in the same relative position. This action should be applied to the body, bearings, and gears. Scribing, bluing, or using a felt pen to mark the outside of the body on the inlet side is suggested to indicate the relative position of the front flange and the rear cover to the body. Mark the bearing blocks also on the inlet side and the gears position relative to each other. DO NOT scribe internal surfaces.

### **IMPORTANT**

**Mark all pieces during disassembly so that the unit can be reassembled correctly. Installing components incorrectly could severely damage the unit and/or cause it to not function properly.**



# GEAR PUMP 1.2

## Disassembly (continued)

### 6. Procedure

1. Clamp the unit in a vice from the flange side (fig. C3973). Make sure the vice jaws are clean and have smooth surfaces to prevent damage to the pump. Clamping the pump body is not recommended because serious damage to the surfaces, on which the ports are located, may occur.

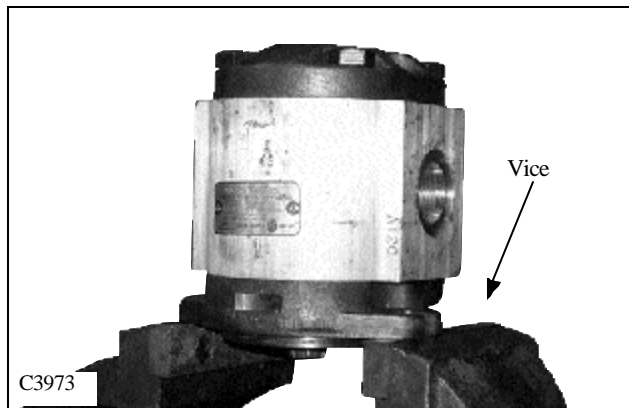

2. Use a 19mm socket wrench to loosen the four bolts on the rear cover (fig. C3974). Next completely unscrew the bolts and remove them. Inspect the threads for damage (fig. C3975).

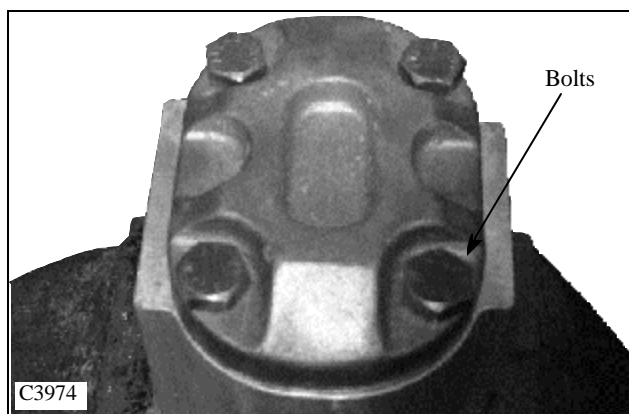

3. Place the pump on the table and slowly remove the front flange (fig. C3976). Note, some units have a shaft seal and others do not. Should your unit have the shaft seal, be careful not to damage it when removing the front flange. Inspect the front flange and seal area.

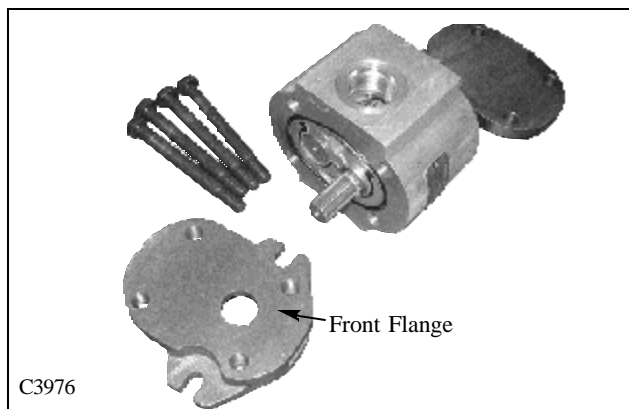
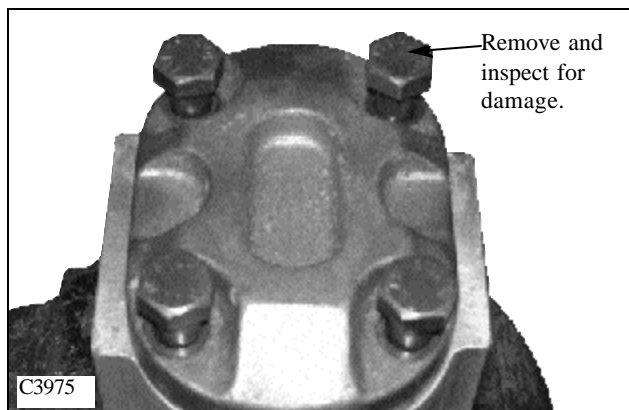

# 1

## GEAR PUMP 1.2

### Disassembly (continued)

#### 6. Procedure

4. Place the pump on it's side. While disassembling the unit, you need to mark the relative positions of the gear mesh (drive gear tooth and idler gear tooth) and the bearing blocks to the body so they can be reassembled in the same position. Carefully remove the bearing block and gear set (fig. C3977). To accomplish this, hold the pump body and push with your fingers on the rear bearing block.

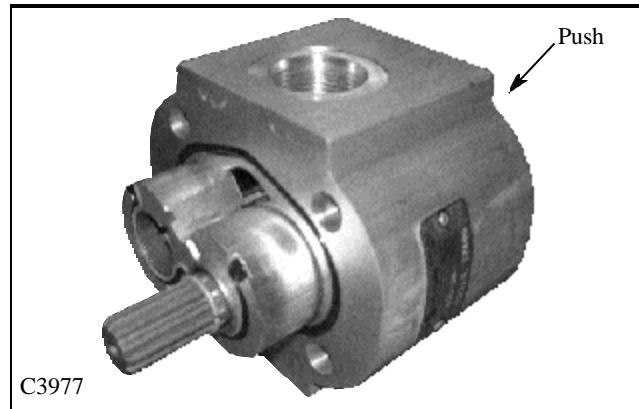

5. Remove the pressure seals taking note how the pressure seals and teflon back up ring are installed (fig. C3978). Check the seal quality. Replacement is recommended whenever there are burrs, evidence of extrusion, or marks caused by overheating. Carefully remove the seals from the bearing blocks beginning with the back up ring then the pressure seal (fig. C3979). Do not use tools with sharpe edges to remove the seals, as damage to the bearing blocks can result. Dispose of any damaged seals.

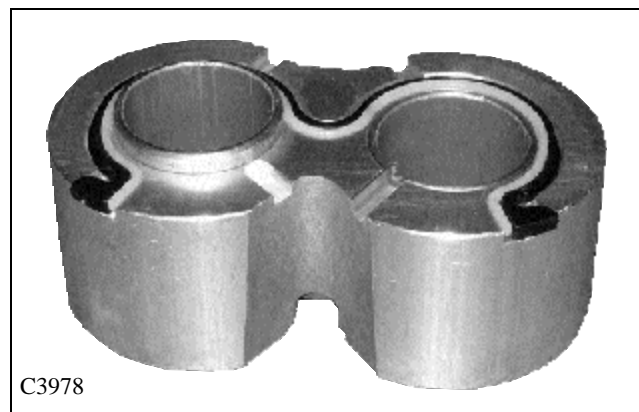

6. Removal of the outer o-ring seals. Check the quality of these two seals. If necessary, replace. Do not use tools with sharp edges to remove the seals, as damage to the housing may result. Discard any damaged seals.

7. Remove the shaft seal in the front flange (if applicable). Place the flange on the work surface. Using internal snap ring pliers, remove the snap ring. Check the seal quality and remove it if necessary. To remove, pry the bottom of the shaft seal and force it out while rotating the flange to lift it out evenly. Do not use the flange pilot to gain leverage as damage may result. Use a plastic rod or wooden dowel as a fulcrum. After removal, dispose of the damaged seal.

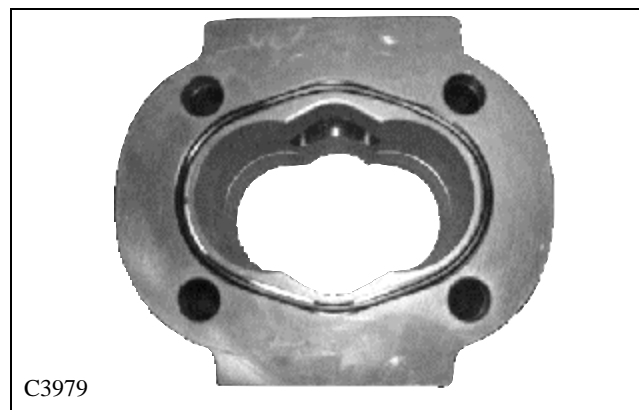

# GEAR PUMP 1.2

## Assembly

1

1. Have the entire seal kit available and laid out neatly on the table (fig. C3980). Compare the old seal kit to the new one to ensure you have the correct one. Lightly coat all seals with seal grease. The grease is needed to adhere the seals in their grooves. **DO NOT INSTALL DRY SEALS!**

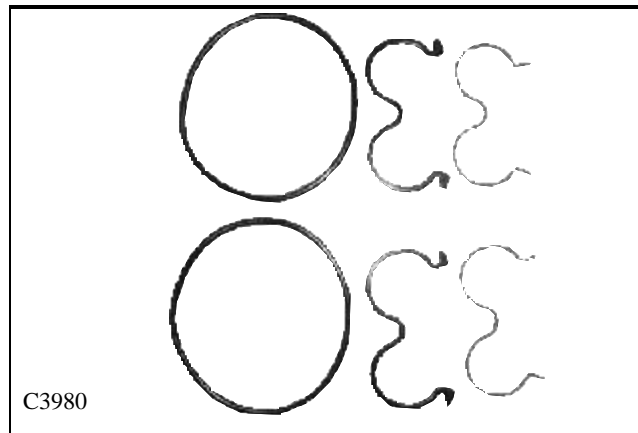

2. Install the shaft seal into the front flange (if applicable). Prepare the flange and shaft seal by lightly lubricating with grease. Seat the seal in the flange by hand. Then, using a shaft seal installation tool press the seal until the tool stops on the flange. This will insure the seal is inserted to the proper depth.

3. Install the snap ring using internal snap ring pliers (fig. 3981). Ensure the snap ring fits securely in its groove. This is necessary to retain the shaft seal.

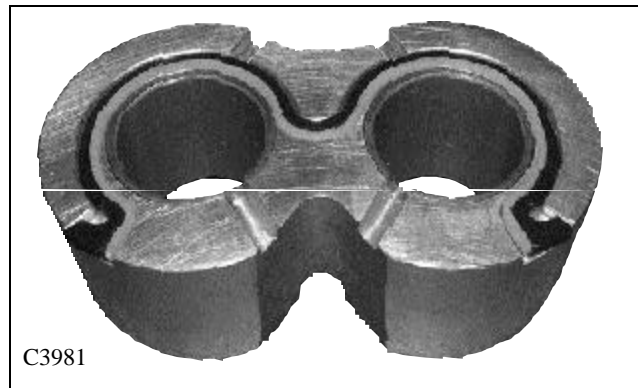

4. Prepare the body by cleaning it. Inspect the internal and mating surfaces. Ensure the surfaces are free of burrs and scratches. Check both the bearing block mating surface and the cut-in path.

5. Prepare the gears (fig. C3982). Caution, the gear surfaces are superfinished. Residue on hands and fingers may be corrosive to this surface. **DO NOT TOUCH.** Carefully clean the two gears. Inspect the journals and the flat faces on the top and bottom of the gears. Ensure these surfaces are free from burrs or scratches. If scratches are found, clean them with a flat stone and/or very fine emery paper. Rewash the gears after this operation.

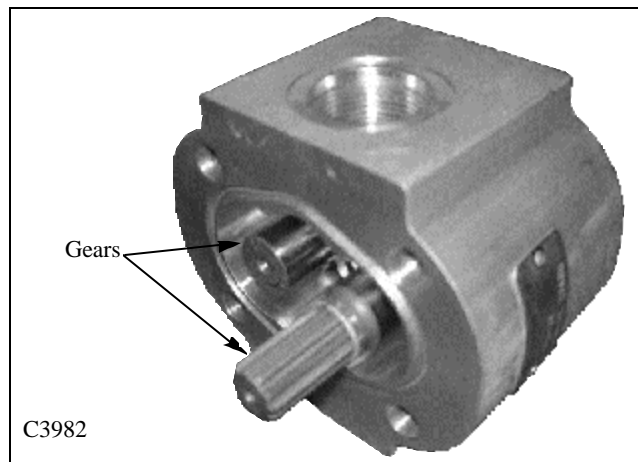

# GEAR PUMP 1.2

## 1

### Assembly

6. Prepare the bearing blocks by cleaning both blocks (fig. C3983). Inspect the flat surfaces of the bearing blocks for burrs or scratches on the edges. If necessary, remove burrs with very fine emery paper. Then rewash the bearings. Inspect the DU bushings for wear. There should be no bronze showing. Using clean hydraulic oil, lubricate the internal and external surfaces of your blocks.

7. Assemble the bearing blocks and gears. Lubricate the journals and gear faces. Assemble the bearing blocks and gears in the same orientation that it was disassembled. Align all marks made during disassembly. Ensure the front and rear block occupy the same location with respect to the housing as they did before disassembly. Misalignment of the gear teeth may increase operating noise.

8. Install the gear and block assembly into the body of the cavity. Align the assembly marks to ensure that the gear block assembly is installed with the same orientation as before assembly.

9. Once the gears and the bearing blocks are installed into the housing, clean the mating surfaces. Remove any excess lubrication and grease from the mating surfaces of the pump body. Ensure that these surfaces are dry and free of contamination before moving on to the next step. Install the o-rings and back-up rings on both the bearing blocks and the housing (fig. C3984).

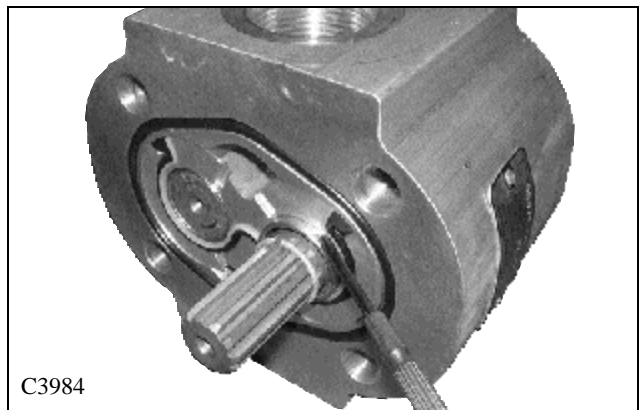
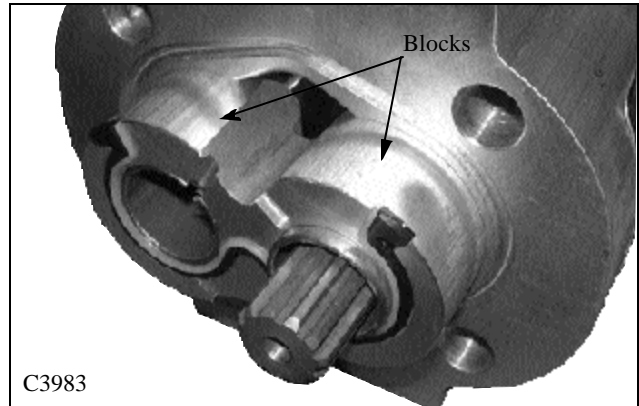

# GEAR PUMP 1.2

## Assembly

10. Remove any excess lubrication and grease from the mating surfaces of the front flange and rear cover. Ensure that these surfaces are dry and free of contamination before moving on to the next step.

11. Install the four bolts through the rear cover then slide the assembly onto the rear of the housing (fig. C3985). Before you slide the cover against the housing, check to make sure all o-rings and the back-up seal are seated properly with no foreign material on them. If they get pinched or there is foreign material on an o-ring, you may get internal or external leakage.

12. Install the front cover (fig. C3986). While keeping pressure on the front flange and the rear cover so the o-rings won't move out of place, set the unit in a vise with the front in the jaws.

13. Torque the four bolts by criss crossing back and forth a little at a time until you reach the final torque.

14. After the pump has been disassembled and reassembled it is suggested that the pump be run in and tested on an appropriate test stand. This is done to verify the volumetric efficiency and the integrity of the unit.

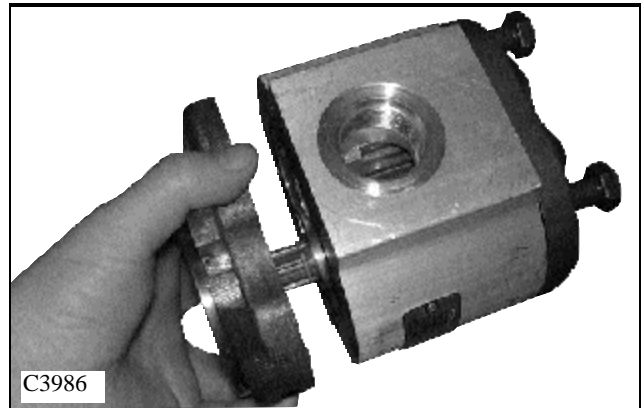
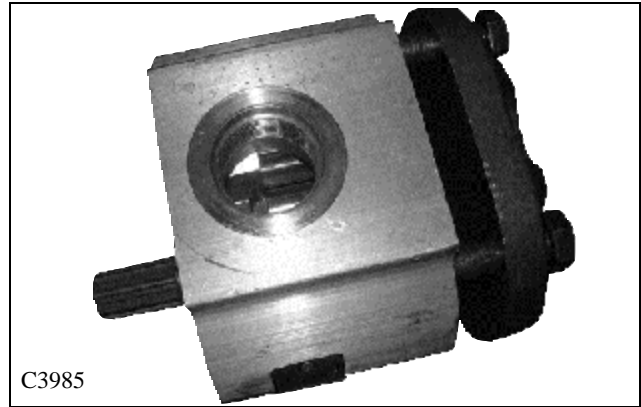

# 1

## CONTROL VALVE 1.3

### Testing and Adjusting the Relief Valve Pressure

Hoses and gauges required for this test must be capable of withstanding 5000 PSI (207 Bar) continuous pressure, and hydraulic flow meter capable of measuring 30 gallons per minute. (113 LPM) (fig. C3432) **This test also checks the status of the gear pump capacities.**

Pressure fluctuations may be caused by restricted oil flow through the relief valve. The relief valve filter may need serviced as outlined in the control valve disassembly section on pages 1-9 through 1-13.

1 Install the flow meter / pressure tester to the auxiliary hydraulic quick couplers. The female coupler attached to the loader provides the power out when the auxiliary control is engaged. (fig. C3646) Connect the flow meter and pressure gauge inlet side to match the power out of the female auxiliary coupler to prevent meter and gauge damage. Be sure to connect a return line to the male auxiliary hydraulic quick coupler. (fig. C3433)

2 Start the engine and engage the auxiliary hydraulic system. Increase the engine speed to full operating RPM. (See Section 7 for checking and adjusting engine speed to 2800 RPM plus or minus 25 RPM)

3 Turn the flow control valve on the flow meter to restrict the oil flow down to 2 GPM. (7.5 LPM) As you are turning the flow control valve, watch the pressure gauge and make sure it does not go over 3000 PSI.(207 Bar) Stop further adjustment immediately if the reading goes over this setting. Shut off the auxiliary hydraulic

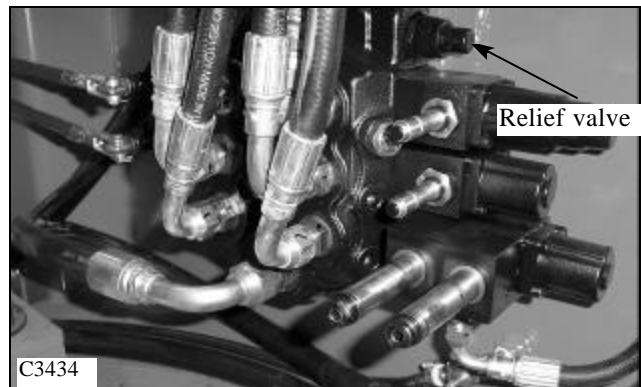
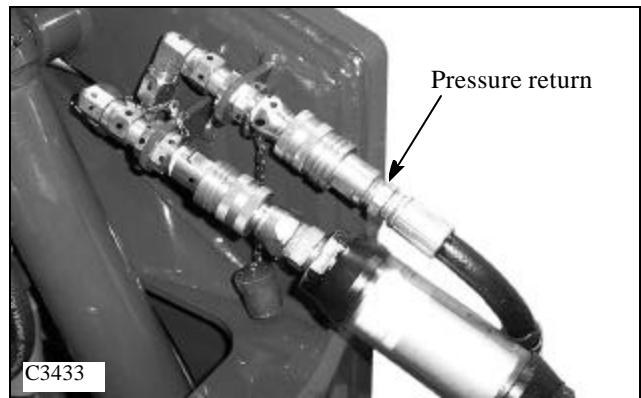
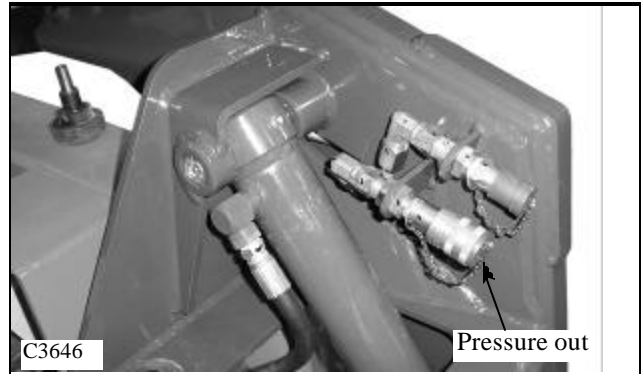
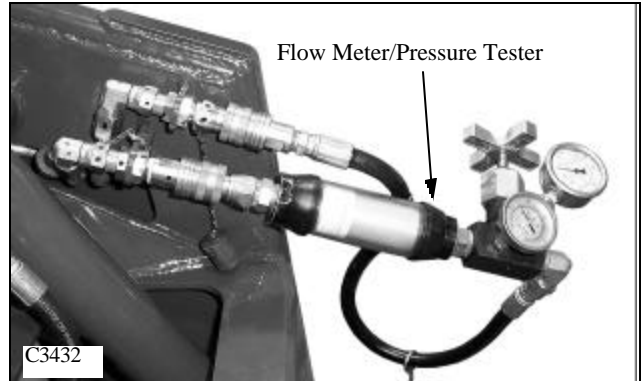

#### CAUTION

**Adjusting the relief valve setting too high may cause damage to the gear pump.**

system and shut off the engine. Move to step 6 to make initial setting.



#### WARNING

**To prevent personal injury or damage to the loader, do not adjust the relief valve while the engine is operating.**

# CONTROL VALVE 1.3

1

4 Repeat steps 2 and 3 if necessary. Allow the loader to operate at this setting until the oil temperature has increased to 160° F (71°C), operating temperature.

5 Turn the flow control valve further to restrict the oil flow to no flow. (Zero) Correct pressure setting is 2400 PSI +/- 100 PSI. (165 Bar, +/-6.9 Bar)

6 If adjustment is necessary, shut down the auxiliary hydraulic system, shut off the engine and return the flow control valve to the open position. Locate the control valve in the engine compartment.

7 Loosen the jam nut on the relief valve adjusting screw and turn the screw clockwise, counting the turns, until the screw bottoms out. (fig. C3435)

8 Turn the screw back out lesser turns than you turned in to increase pressure, or out more turns to decrease pressure.

9 Retake the pressure readings by performing steps 2 through 5. If necessary make further adjustments by repeating steps 6 through 9.

**NOTE: If inadequate pressure and / or flow is not available, the gear pump could be failing, the intake to the gear pump is restricted, or the filter in the relief valve is clogged. (See pg. 25 for filter replacement).**

## Control Valve Replacement

1 Remove any attachment and shut off the engine

### IMPORTANT

**Clean the work area prior to repair. Cap all open lines, fittings and ports to prevent contamination.**

2 Disconnect the control cables, electrical solenoid spool locks, and electrical auxiliary solenoid wiring connectors if equipped. (fig. C3436, C3437)

3 Disconnect the the inlet hose coming from the gear pump. Cap the hose and fitting and remove the adapter fitting in the control valve. (fig. C3436)

4 Disconnect the 6 hoses going to the boom, bucket and auxiliary circuits. Marking the hoses as you remove them is recommended to ease re-assembly and assure the circuits are functioning properly at restart.(fig. C3434)

5 Disconnect the return line from the control valve and remove the adapter fitting. Plug and cap all open ports and hose ends. (fig. C3436)

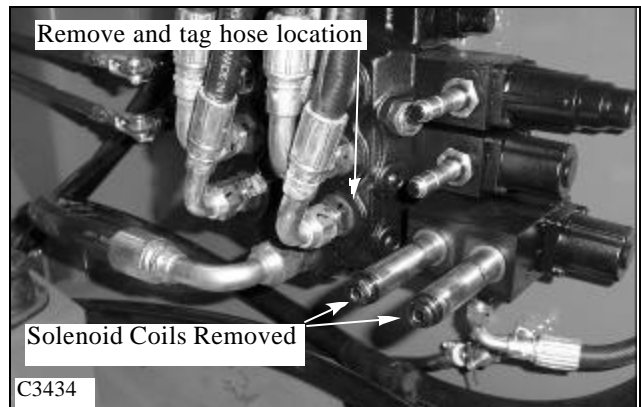
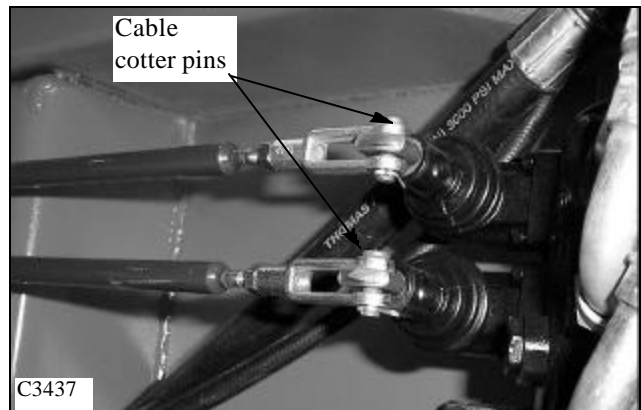
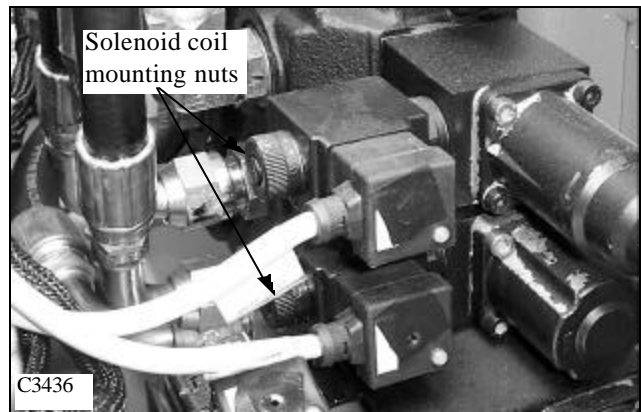
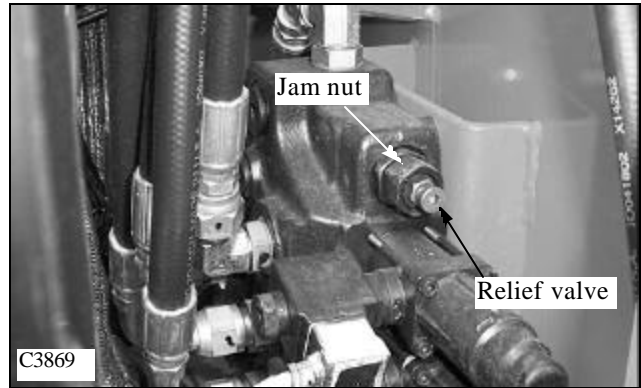

# 1

## CONTROL VALVE 1.3

6 Remove the 3 nuts holding the control valve to the mount and remove the control valve.

7 Remove any fittings left in the control valve. Cap all open ports to prevent contamination. Place these fittings in the new or repaired control valve. Be sure to check all fitting flares and o-rings for damage and replace as required.

### IMPORTANT

Follow the hydraulic fitting torque chart in Section 1.10 when connecting fittings and lines.

8 Assemble the control valve to the loader in the reverse order above. Torque the bolts holding the control valve to the mount at 15 ft / lbs. (20.4 N.m.)

11 After all connections have been made, including the control valve electrical connections, check the oil level in the hydraulic reservoir and top off if necessary.

12 Start the engine and cycle the various hydraulic functions to check for leaks. Make sure the control valve lock system is functioning properly. Do not use your hands to check for leak locations, fluid under operating pressure can penetrate the skin and cause serious personal injury.



### WARNING

Use extreme caution when checking the hydraulic system for leaks. Fluid under pressure can penetrate the skin and cause serious injury.

13 After checking for leaks, you must retest the relief valve setting as outlined on page 1-6 Testing and adjusting.



### WARNING

All safety switches must be connected and functioning to prevent possible operator injury.

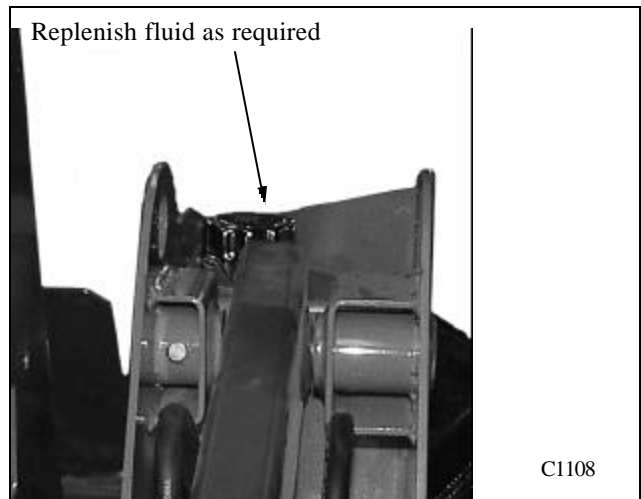
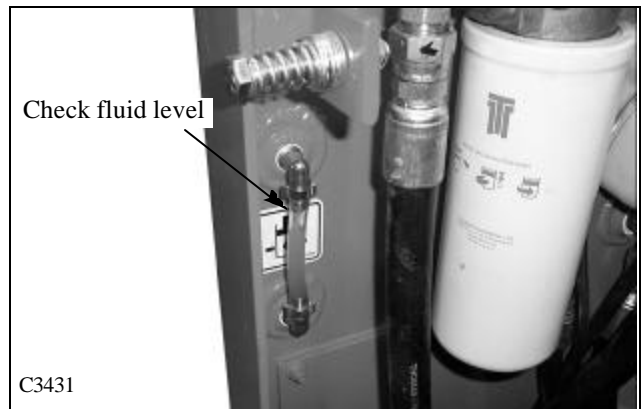
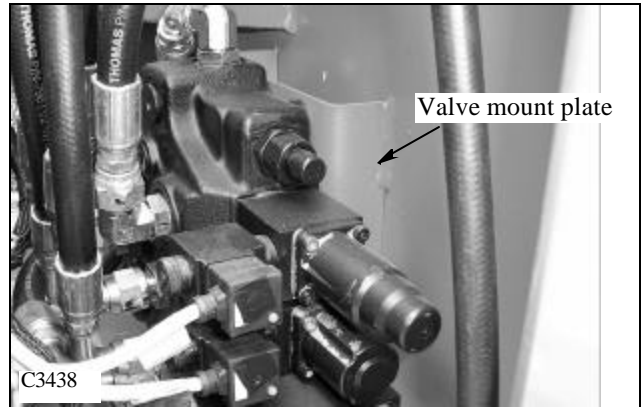



# CONTROL VALVE 1.3

## Control Valve Disassembly (175)

1

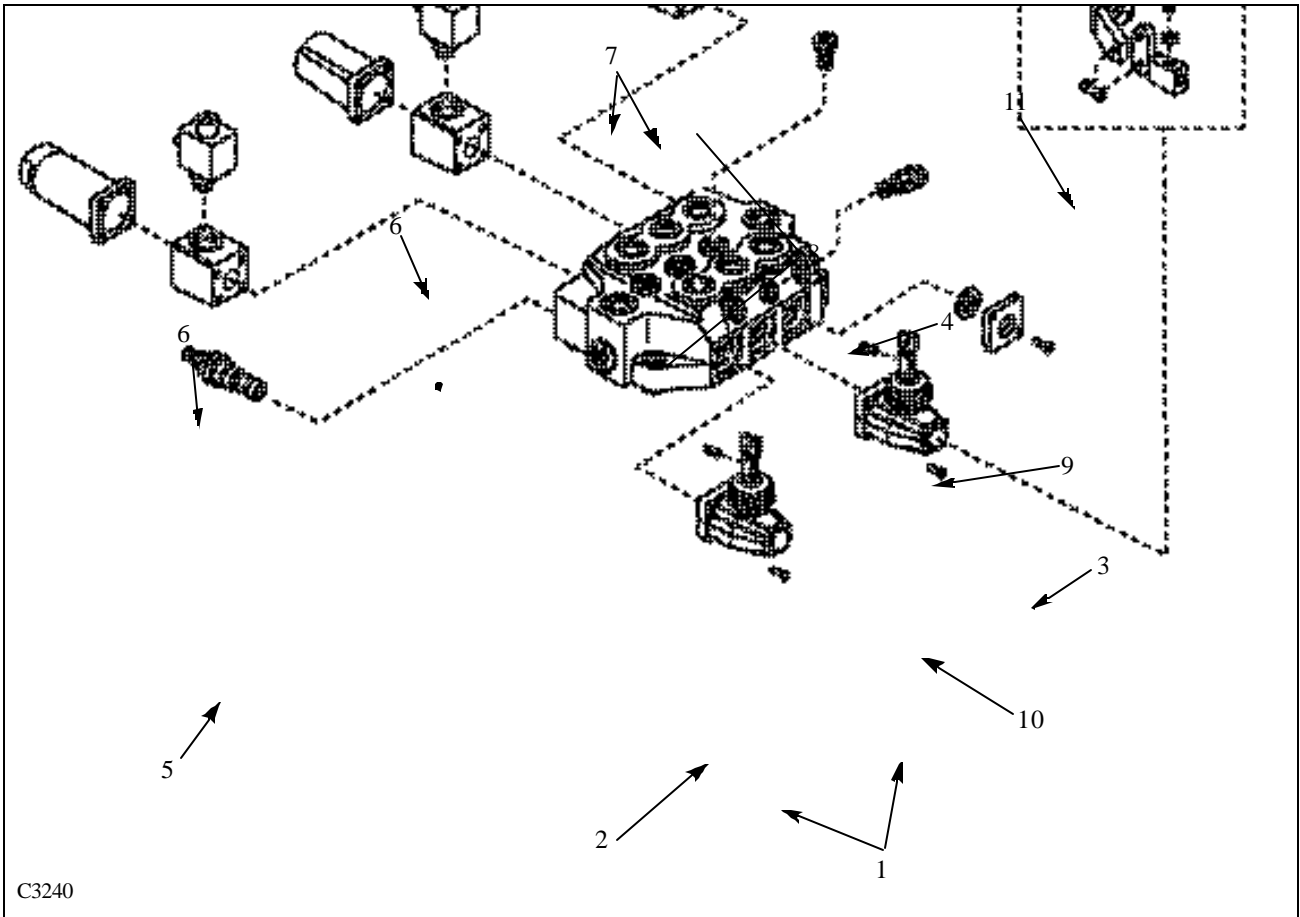

C3240

### Diagram Legend

1. Control Box
2. Set Screws
3. Dust Cap Ass'y Kit
4. Check Valve
5. Main relief Valve
6. Lock Solenoid Coil
7. Auxiliary Solenoid Coil
8. Auxiliary Control With Coils
9. Port Relief Valve
10. Bar
11. Dust Cap With Connector For Hand Controls

# CONTROL VALVE 1.3

1

## Control Valve Disassembly (1700)

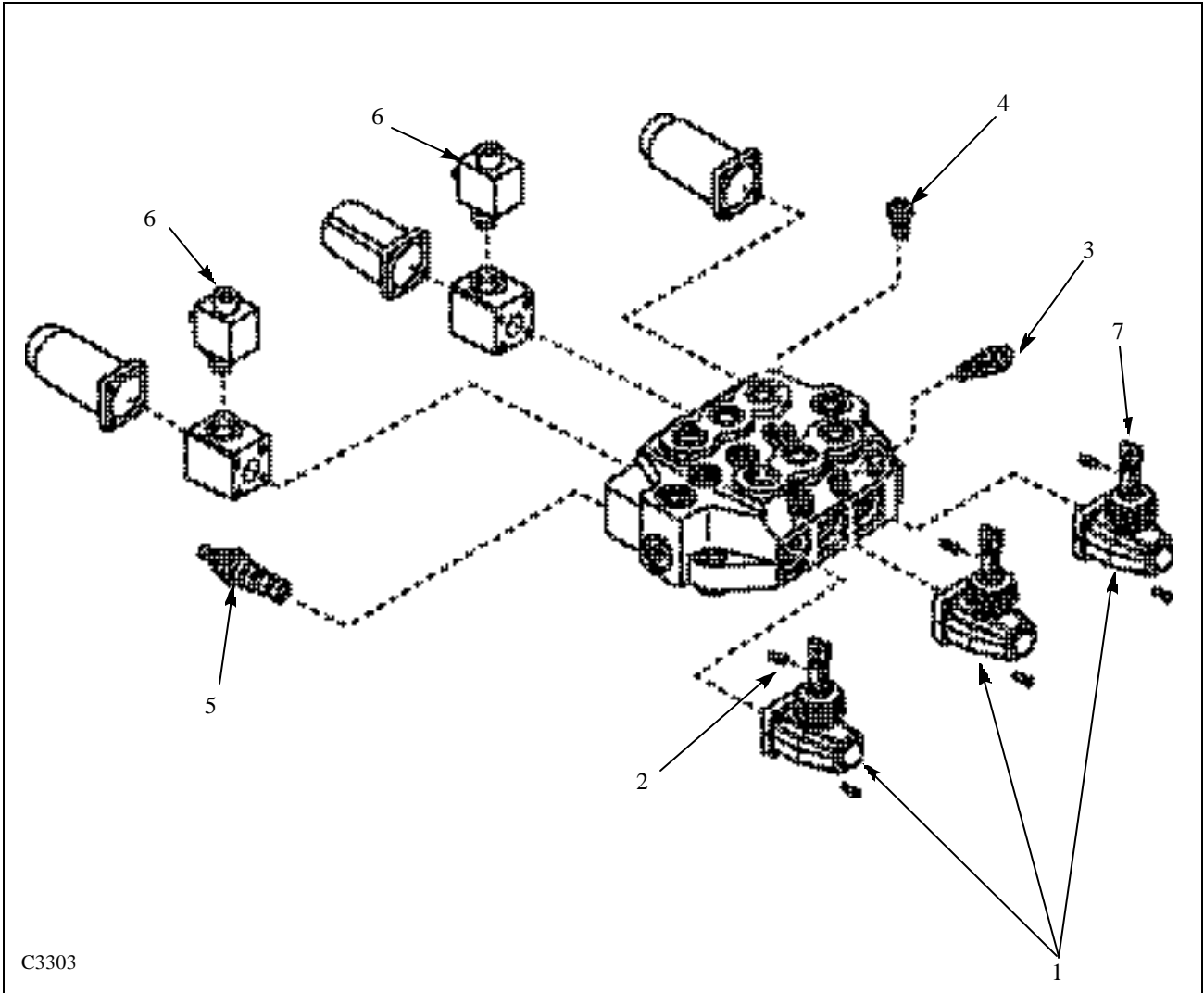

### Diagram Legend

1. Control Box
2. Set Screws
3. Port Relief Valve
4. Check Valve
5. Main Relief Valve
6. Lock Solenoid Coil
7. Bar

# CONTROL VALVE 1.3

## Disassembly / Repair (175)

Before disassembling the hydraulic control valve, clean the body with a suitable solvent and dry with compressed air. (fig. C3696)



### WARNING

To avoid eye injury, use safety goggles when cleaning with compressed air.

Ensure all openings are plugged to prevent solvents and dirt from contaminating the control valve assembly.

1. Remove the pressure relief valve. Discard the O-rings. (fig. C3698)

2. Remove the solenoid coils and locking pin from the valve lock block. (fig. C3699) There are 2 O-ring seals located on either side of the solenoid coils.

3. Remove the spring return detent kit and spring center cap locks. (fig. C3704, C3706)

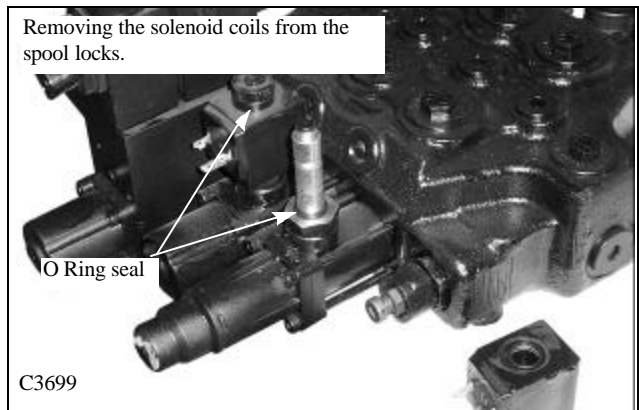
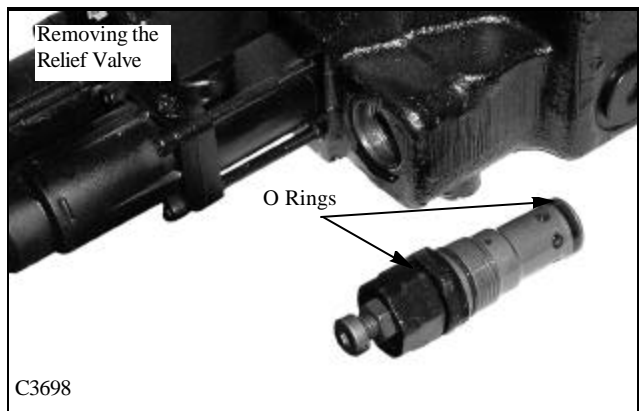
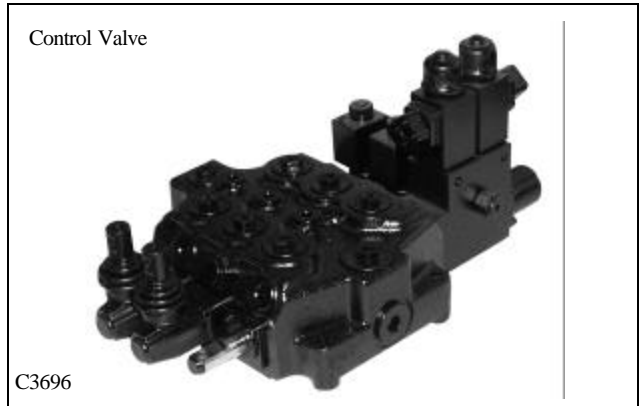

# CONTROL VALVE 1.3

# 1

## Disassembly / Repair 175 (cont'd)

4 Remove the control box from the spool linkage end. (fig. C3709) The box needs to be tilted upward towards the valve to release the hardened ball from the hole in the spool end, and then pull away from the valve.

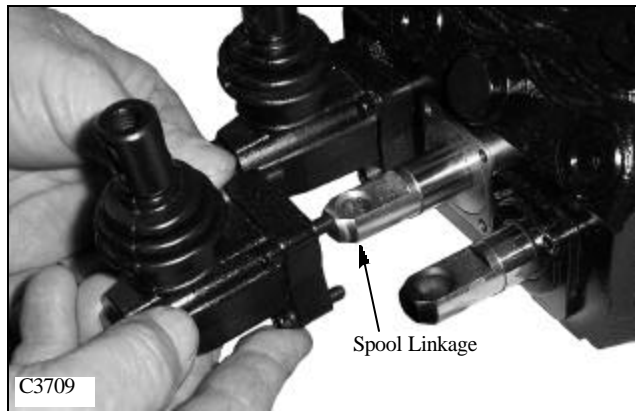

5 Pull out the spool. (fig. C3713) As you pull out the spool, note it's smooth action as it comes out of the valve body. The spool should move freely and smoothly in the bore of the valve body. Check the control valve spool and bore for scuff marks or abnormal wear. Replace the spool and or control valve if signs of wear are present.

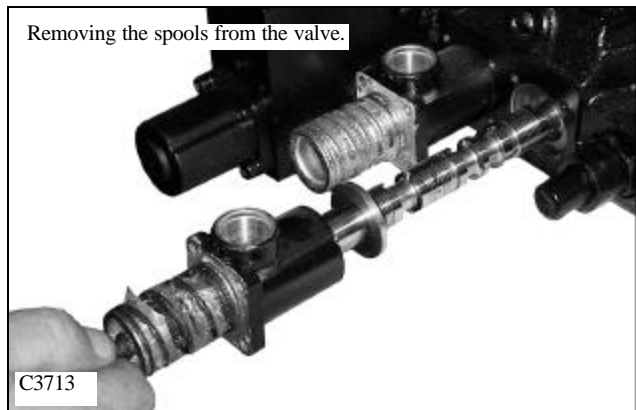

6 Remove the check valves from control valve body. (fig. C3717) They are located between the ports of each section. Check the seat and poppet of the valve body and check valve. Replace the check valve and or the control valve if any signs of wear are present.

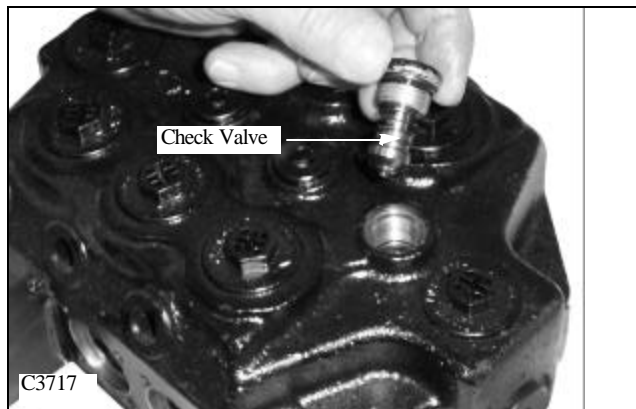

# CONTROL VALVE 1.3

1

## Disassembly Repair 175 (cont'd)

7 When replacing the spool to the control valve, use new O-ring seals and apply system oil to the O-rings and spools. (fig. C3718).

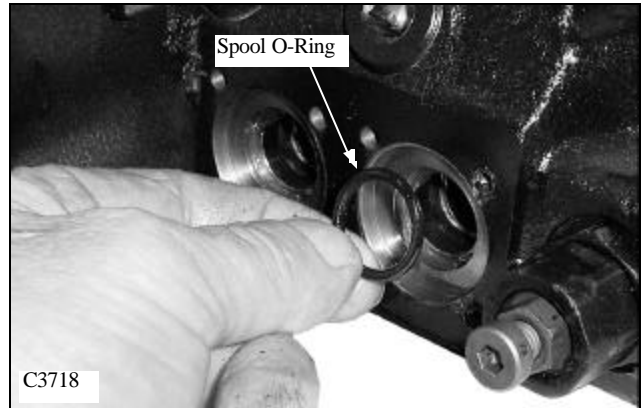

8 Fit the seal washer to the control valve with the beveled side of the washer facing the control valve. (fig. C3719) Fit the spool to the control valve now if repairs are not needed to the detent or spring return mechanism. Use system oil to lubricate the spool before inserting to the control valve.



9 Place the cable end of the spool in a vice, or insert a screw driver through the clevis pin holes, to keep it from turning. The detent is threaded to the spool and can be removed for inspection or repairs.(fig. C3724)

Replace broken springs, worn detents and / or damaged detent balls with a new detent kit.

Apply Loctite 542 to the threads of the detent when installing to the spool.

Apply Castrol "Sphero"l" TN grease to the inside of the spring cover.



10 When installing the detent to the control valve spool, apply Loctite type (542) to the threads. Tighten the detent to the spool at 24 Nm (17.7 lbs / ft). (fig. C2254)



# 1

## CONTROL VALVE 1.3

### Disassembly / Repair 175 (cont'd)

11 Install the spring return / centering cover and tighten the mounting screws evenly to 6.6 Nm (4.9 lbs / ft). Install the end cap to the cover and tighten to 9.8 Nm (7.2 lbs / ft). (fig. C2258)

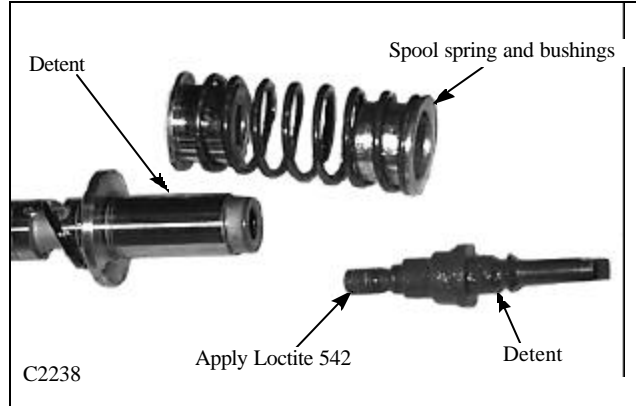

12 Install the spring return / centering cover and tighten the mounting screws evenly to 6.6 Nm (4.9 lbs / ft). Install the end cap to the cover and tighten to 9.8 Nm (7.2 lbs / ft). (fig. C2258)

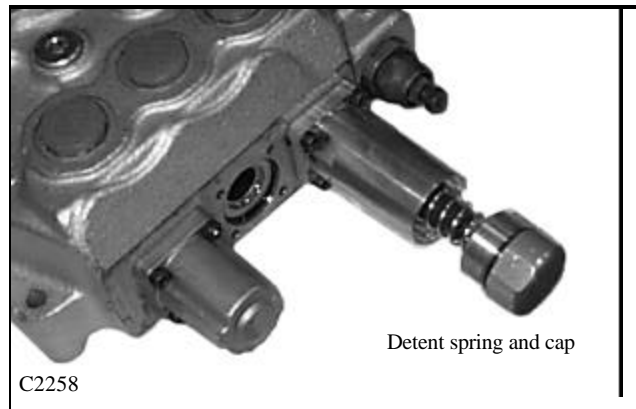

### Solenoid Controlled Auxiliary

- 1 Remove the rubber boot covering the retaining nut on top of each solenoid coil.
- 2 Remove the nut and O-ring and pull off the solenoid coil (s). (fig. C3720)

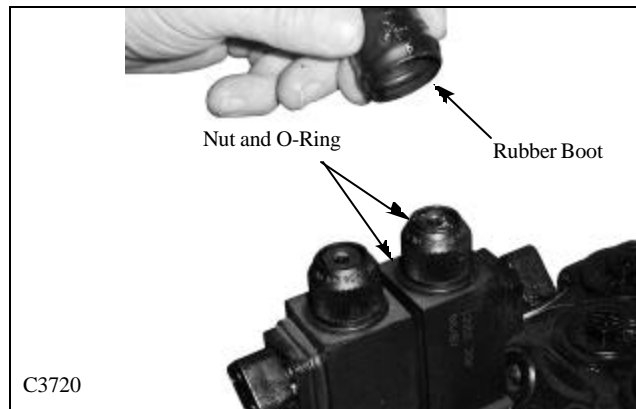

3 Remove the screws retaining the solenoid assembly to the control valve. (fig. C3722). Upon assembly tighten the screws to 6.6 Nm (4.9lbs / ft).

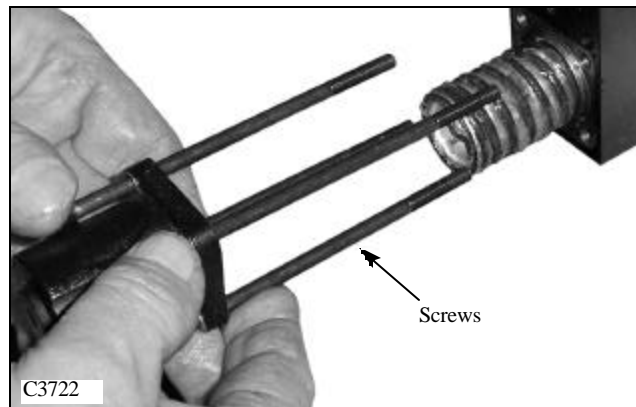

# CONTROL VALVE 1.3

1

## Disassembly / Repair 175 (cont'd)

4 Remove the solenoid spool assembly from the control valve. (fig. C3723) Note the effort required to remove the spool from the spool bore. It should come out smoothly without binding or “snagging” throughout it’s travel.

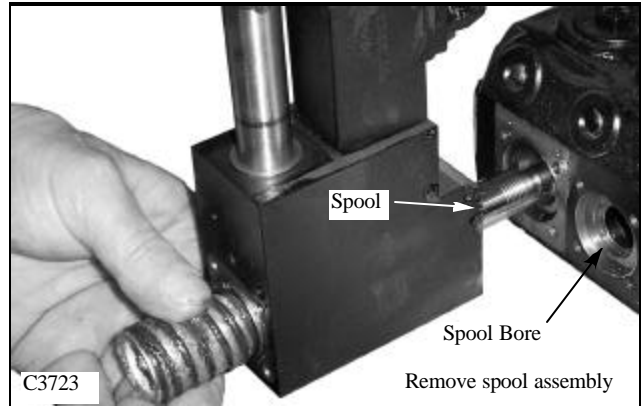

5 Inspect the spool and spool bore for abnormal wear. (fig. C3763) Replace the spool and / or the control valve if large scratches or indentations are present in the spool or spool bore. Minor scratches can be removed from the spool with extra fine emery cloth.

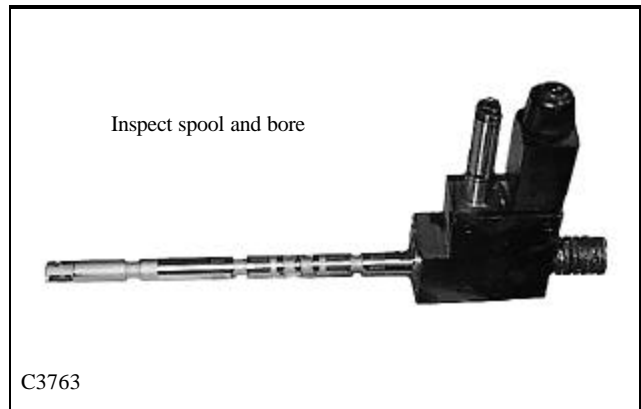

6 Remove the spool from the cylinder assembly by pushing the spool rearward through the cylinder. (fig. C2263) The spool will not pull through the front.

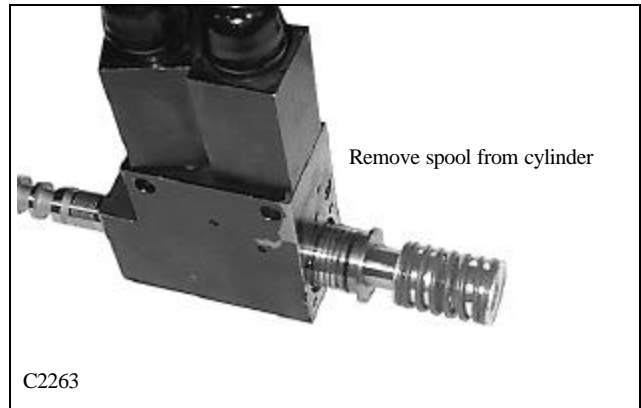

7 The piston part is machined with a nail head type pin that fits to a machined notch in the spool. (fig. C2264) Separate the spool from the piston and spring assembly.

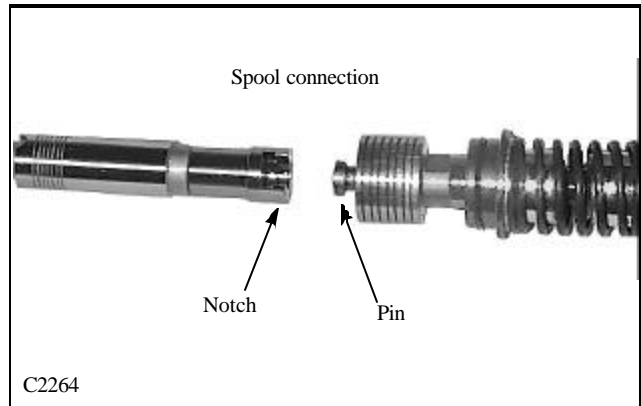

# CONTROL VALVE 1.3

# 1

## Disassembly / Repair 175 (cont'd)

8 Pull the flange and O-ring seal back toward the spring to expose the machined hex of the piston. Hold the hex with a wrench while removing the spring and spring bushings from the piston assembly. (fig. 2265) When installing the spring assembly to the piston, apply Loctite 542 to the threads and tighten the screw to 24 Nm (17.7 lbs / ft).

**NOTE:** The rest of the parts in the cylinder assembly are deemed non serviceable, replacement only.

9 The O-ring in the front part of the cylinder, next to the valve body, is mounted to a flange and is removed by inserting a brass punch through the rear of the cylinder and gently tapping it out. (fig. C2280)

10 Upon assembly, use new O-ring seals. (fig. C3718) Don't over look the small O-ring seal between the cylinder and valve body. (fig. C2250) Lubricate the spool O-ring seals with system oil. Apply Castrol "Spheerol" grease to the inside of the spring covers.

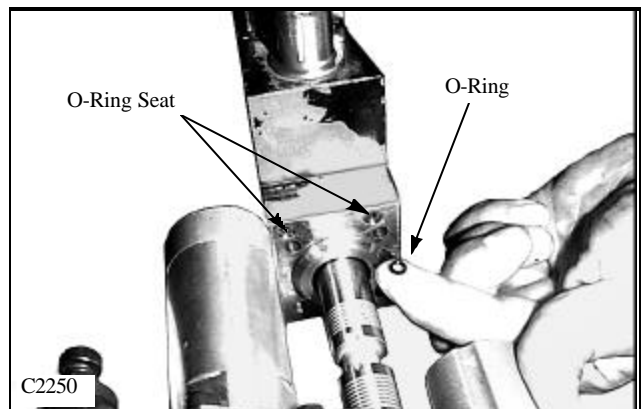
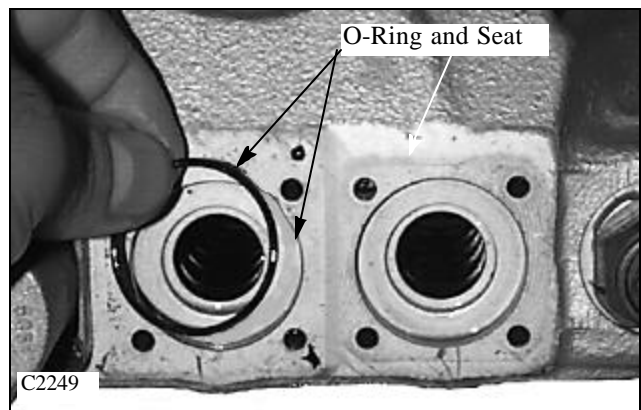
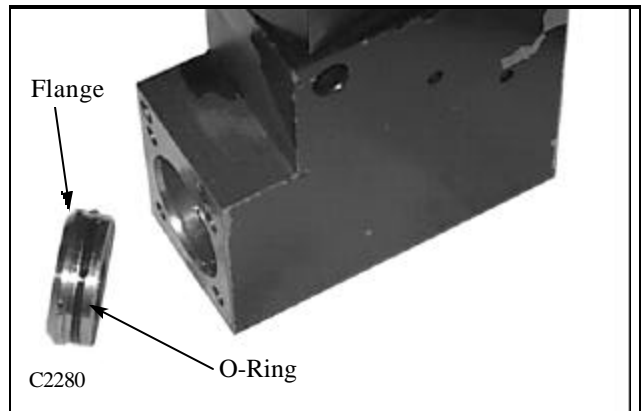
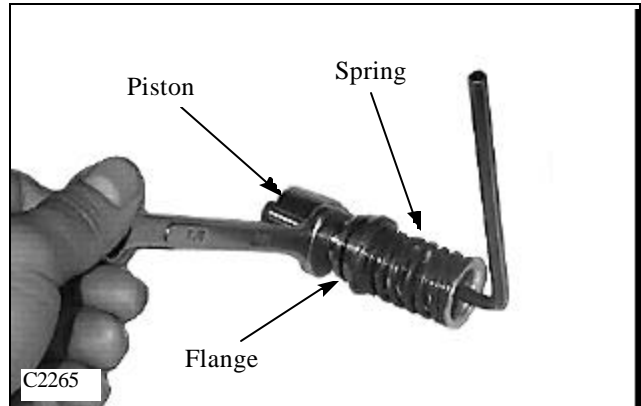



# CONTROL VALVE 1.3

## Disassembly / Repair 1700

Before disassembling the hydraulic control valve, clean the body with a suitable solvent and dry with compressed air. (fig. C3744)



### WARNING

To avoid eye injury, use safety goggles when cleaning with compressed air.

Ensure all openings are plugged to prevent solvents and dirt from contaminating the control valve assembly.

1. Remove the pressure relief valve. Discard the O-rings. (fig. C3746)

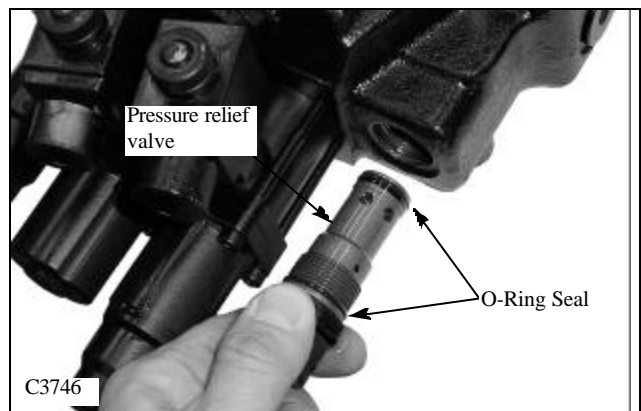

2. Remove the solenoid coils and locking pin from the valve lock block. (fig. C3748) There are 2 O-ring seals located on either side of the solenoid coils.

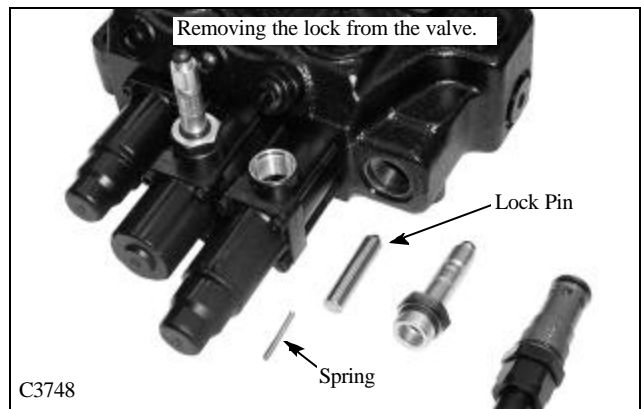

3. Remove the spring return detent kit and spring center cap locks. (fig. C3749)



# CONTROL VALVE 1.3

1

## Disassembly / Repair 1700 (con't)

4 Remove the control box from the spool linkage end. The box needs to be tilted up towards the valve to release the hardened ball on the control box pin from the hole in the spool end and pull it away from the valve. (fig. C3752).



5 Pull out the spool. (fig. C3754) As you pull out the spool, note it's smooth action as it comes out of the valve body. The spool should move freely and smoothly in the bore of the valve body. Check the control valve spool and bore for scuff marks or abnormal wear. Replace the spool and or control valve if signs of wear are present.



6 Remove the check valves from the control valve body (fig. C3757). They are located between the ports of each section. Check the seat and poppet of the valve body and check valve. Replace the check valve and/or the control valve if any signs of wear are present.

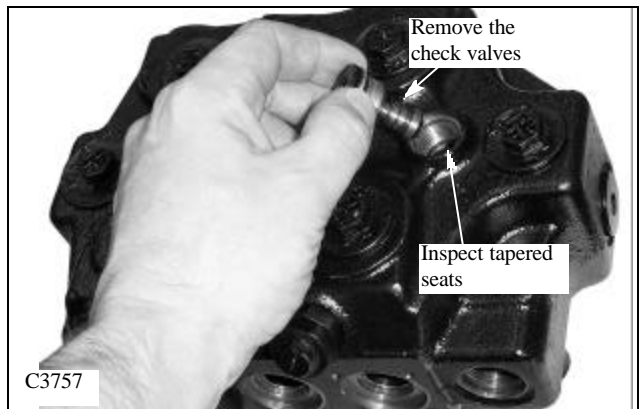

# CONTROL VALVE 1.3

## Disassembly / Repair 1700 (con't)

7 When replacing the spool to the control valve, use new O-ring seals and apply system oil to the O-rings and spools. (fig. C3718).

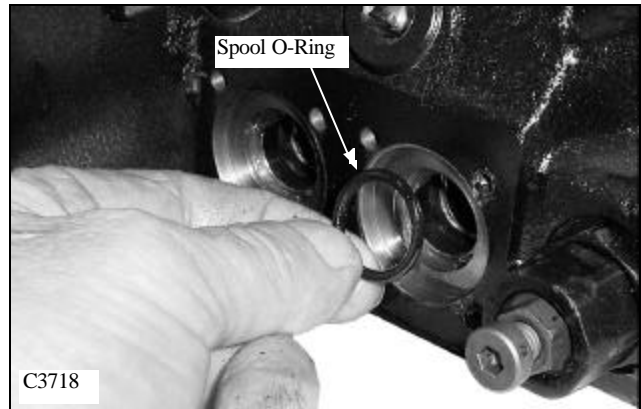

8 Fit the seal washer to the control valve with the beveled side of the washer facing the control valve. (fig. C3719) Fit the spool to the control valve now if repairs are not needed to the detent or spring return mechanism. Use system oil to lubricate the spool before inserting to the control valve.

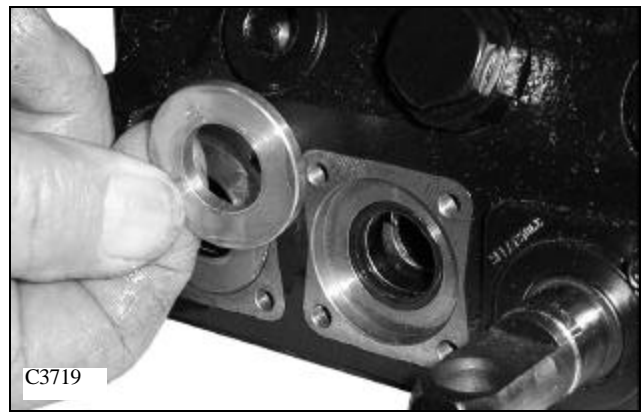

19 Place the cable end of the spool in a vice, or insert a screw driver through the clevis pin holes, to keep it from turning. The detent is threaded to the spool and can be removed for inspection or repairs. (fig. C2238, C2242)

Replace broken springs, worn detents and / or damaged detent balls with a new detent kit.

Apply Loctite 542 to the threads of the detent when installing to the spool.

Apply Castrol "Sphaerol" TN grease to the inside of the spring cover.

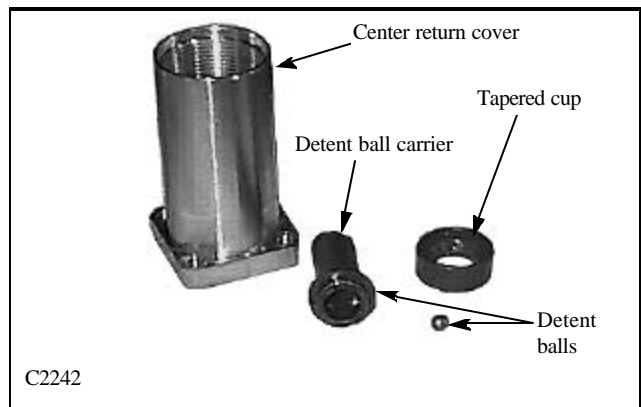
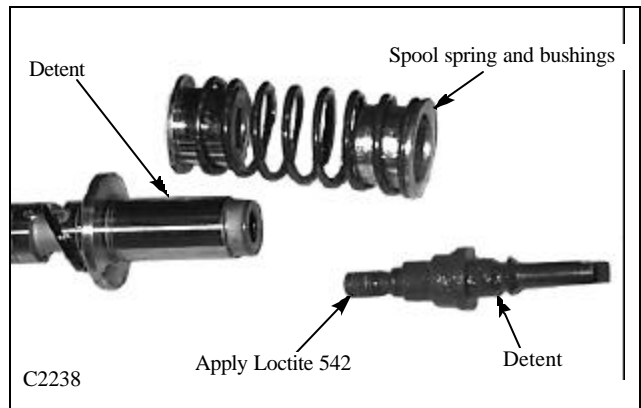

# CONTROL VALVE 1.3

1

## Disassembly / Repair 1700 (con't)

10 When installing the detent to the control valve spool, apply Loctite type 542 to the threads. Tighten the detent to the spool at 24 Nm (17.7 lbs / ft). (fig. C2254)

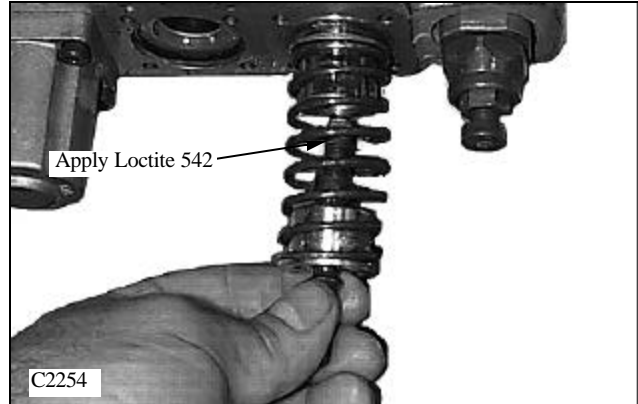

11 Install the spring return / centering cover and tighten the mounting screws evenly to 6.6 Nm (4.9 lbs / ft). Install the end cap to the cover and tighten to 9.8 Nm (7.2 lbs / ft). (fig. C2258)

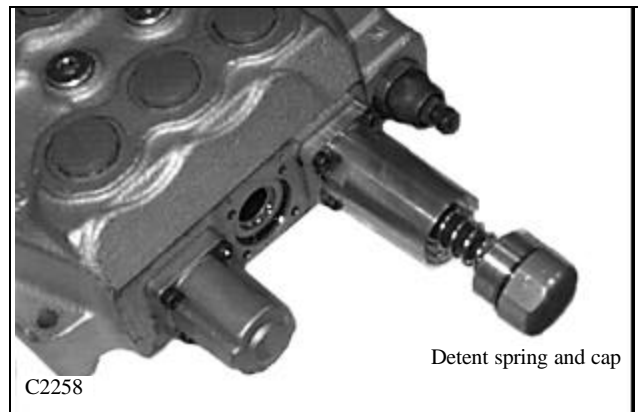

# HYDRAULIC CYLINDERS 1.4

1

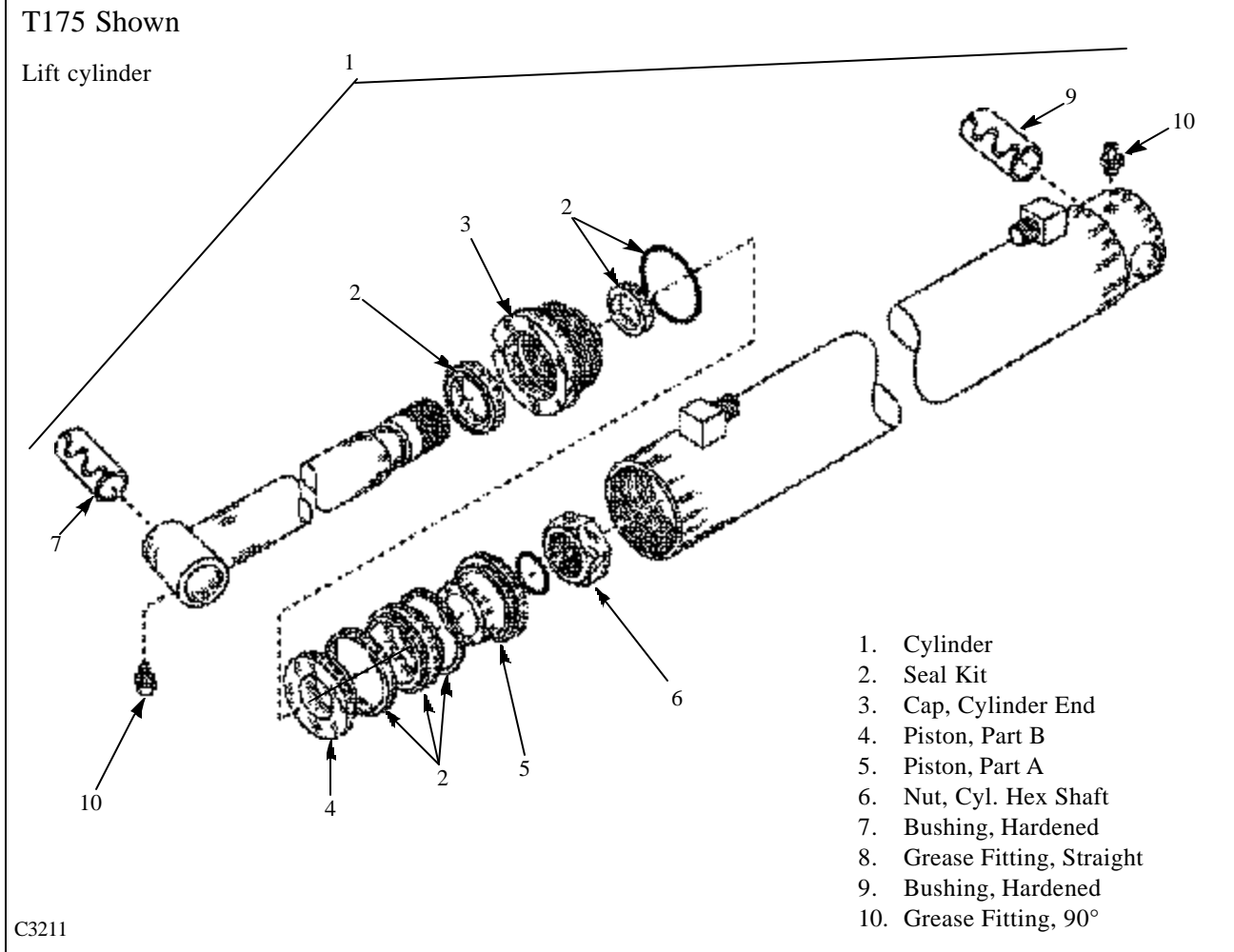

## General Information

All cylinders are a double acting, designed to extend and retract under pressure.

The piston rods, which are made of high strength distortion free material, are precision ground and hard chrome plated. The cylinder barrels are micro honed to close tolerance, straightness and smooth finish for long piston packing seal life.

All cylinders have a 2 piece piston assembly made of ductile iron and a polypac seal arrangement consisting of a piston seal and 2 wear rings.

The rod seal is a "U" cup design, with the "U" facing the pressurized oil. The rod wiper keeps foreign matter from entering the cylinder by wiping the rod clean as the cylinder retracts.

The gland nut seal is of an "O" - ring design. This seal keeps the oil from leaking around the gland nut and cylinder barrel threads.

Certain cylinders have spacers in them. These spacers are used to limit the stroke of the rod.

Some cylinders also have replaceable hardened bushings in the pivot areas that can be serviced when worn out.

# HYDRAULIC CYLINDERS 1.4

# 1

## Testing the Piston Seals

If the boom or bucket cylinders drift down with the control valve spools in the neutral position, and with no external leaks in the hydraulic system, the following test will indicate if oil is leaking by the cylinder piston seals. With the hydraulic oil at operating temperature and a fully loaded attachment, check that the cylinders do not drop more than 1.5 inches every 3 minutes with the engine off. Before performing this test, ensure the control linkages are not binding and the hydraulic control valve spools are centering in the neutral position. If the test has proven excessive leak down the cylinders may be further tested in the following manner.

### IMPORTANT

**Allowable boom or bucket cylinder drop: 1.5" in 3 minutes, @ loaded rating and operating temperature.**



### WARNING

**Use extreme caution when checking the hydraulic system for leaks. Fluid under pressure can penetrate the skin and cause serious injury.**

1 This test must be performed with the engine running. Remove any attachment and block the loader securely with all 4 wheels off the ground.

2 Retract the cylinder(s) to be tested. Shut off the engine and cycle the controls to release the hydraulic pressure.

3 Disconnect the hose from the fixed end of the cylinder to be tested. Cap the hose with a steel plug to prevent system charge pressure from escaping the open circuit and to prevent contamination. (fig. C3440, C3441)

4 Start the engine and cycle the control(s) as to retract the cylinder. Do not over activate the controls as to place in the detent position. Have a container can ready to catch any waste oil to prevent environmental contamination.

5 Repeat for all both pairs of cylinders.

6 If oil leaks from the cylinder port the seals are bad and need replacement. If no oil leaks you may need to check the load check valves or spool wear in the hydraulic control valve.

7 Connect the hydraulic hose to the cylinder ports if no further servicing is required.

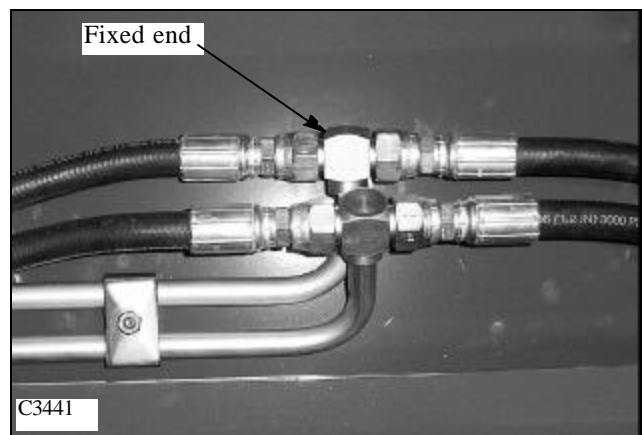
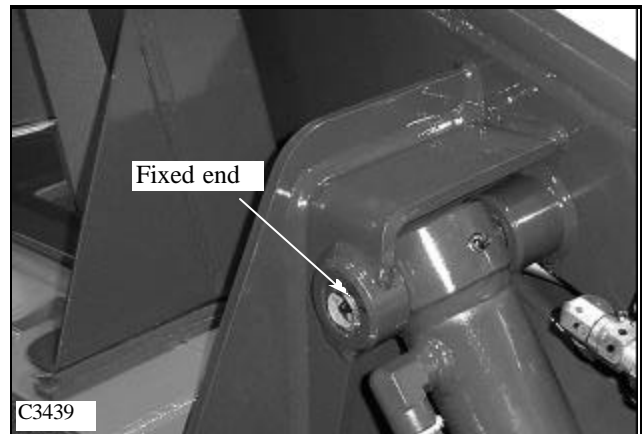
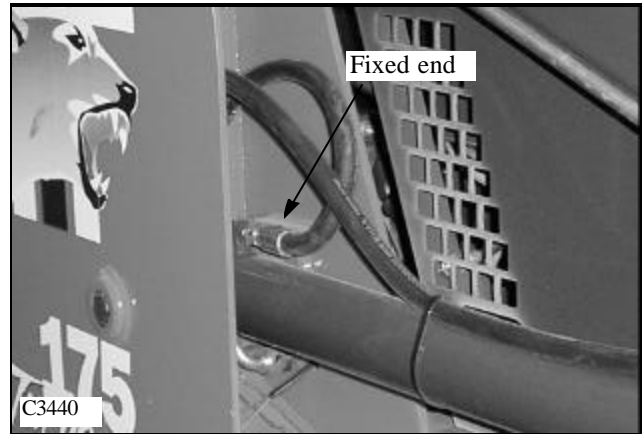

# HYDRAULIC CYLINDERS 1.4

## Lift Cylinder Replacement



### WARNING

To prevent personal injury never repair or tighten hydraulic hoses while the engine is operating or the system is under pressure.

The following procedure will assist you in cylinder removal.

For removal of the boom cylinders:

### IMPORTANT

Cap all open lines and ports to prevent contamination.

- 1 Lower the boom arms, stop the engine and cycle the controls to relieve any hydraulic back pressure in the system. Lock the control in the float or detent position.
- 2 Remove the hydraulic hoses from the cylinder. (fig. C3601) Cap all open ports and lines to prevent contamination.
- 3 Remove the lock nut and bolt from both mounting pins. (fig. C3601, C1864)
- 4 Remove the front pivot pin by pushing the pin out from behind the boom arm, out toward you. (fig. C3647) With an appropriate punch and hammer to prevent brooming of the pin, remove the rear pin. (fig. C3648) Brooming the pin makes it difficult to remove.
- 5 Remove the cylinder from the loader.
- 6 Upon replacement, inspect the pivot pins and cylinder bushings for any wear. Replace if necessary. Reverse order above for installation.
- 7 Upon start up, check for system leaks and replenish the hydraulic reservoir as required.



### WARNING

Use extreme caution when checking the hydraulic system for leaks. Fluid under pressure can penetrate the skin and cause serious injury.

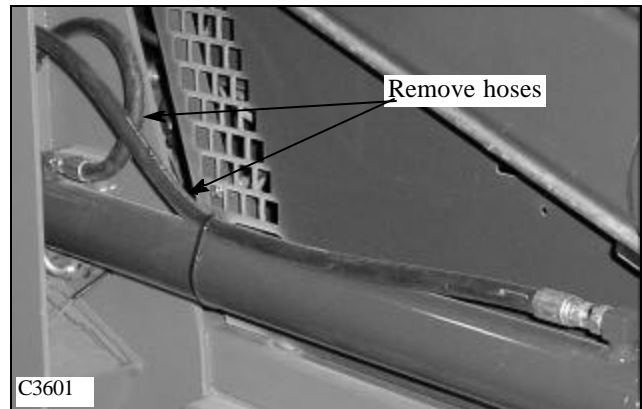

C3601

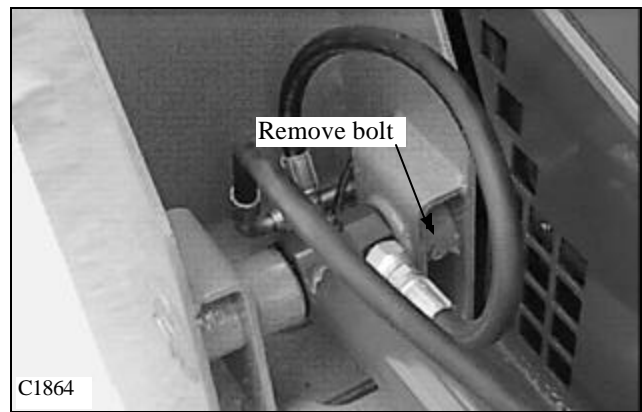

C1864

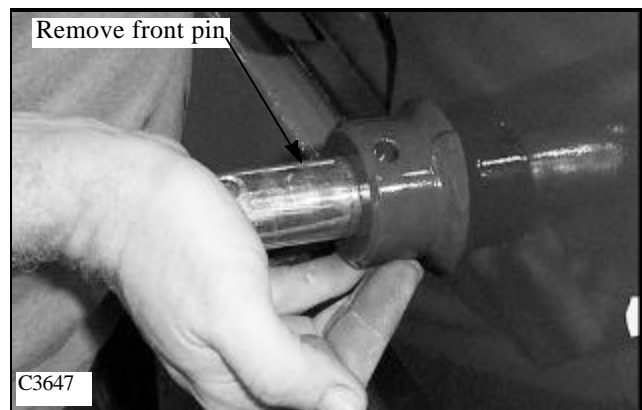

C3647



C3648

# HYDRAULIC CYLINDERS 1.4

# 1

## Tilt cylinder Replacement

For tilt cylinder removal:

- 1 Lower the boom arms, remove any attachment and extend the tilt cylinders. Shut off the engine and cycle the controls to relieve excessive back pressure in the hydraulic system.(fig. C3649)
- 2 Loosen or remove the hydraulic hoses from hydraulic tubing under the boom arm step if you are changing the hoses also. (fig. C3441)
- 3 Remove the hydraulic hoses from the tilt cylinder. Plug and or cap all open ports or lines to prevent contamination. (fig. C3439)
- 4 Remove the lock nuts from the bolts retaining the pivot pins to the loader and remove the bolts. (fig. C3649)
- 5 Remove the pivot pins by tapping out with a brass drift pin. (fig. C3646)
- 6 Remove the cylinder from the loader.
- 7 Upon reassembly, inspect the pivot pins and bushings for wear and replace as required. Reverse order for cylinder installation.
- 8 Upon start up, check for system leaks and replenish the hydraulic oil reservoir as required.

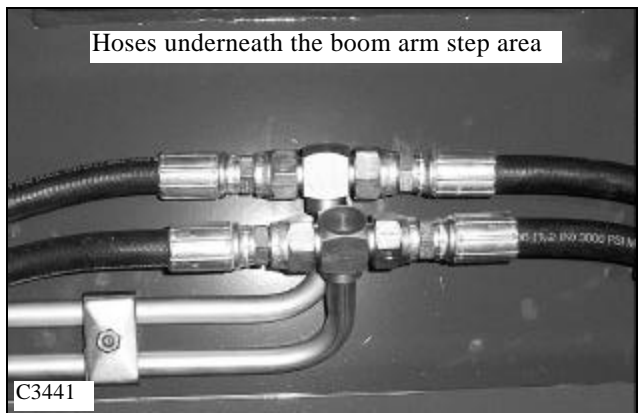
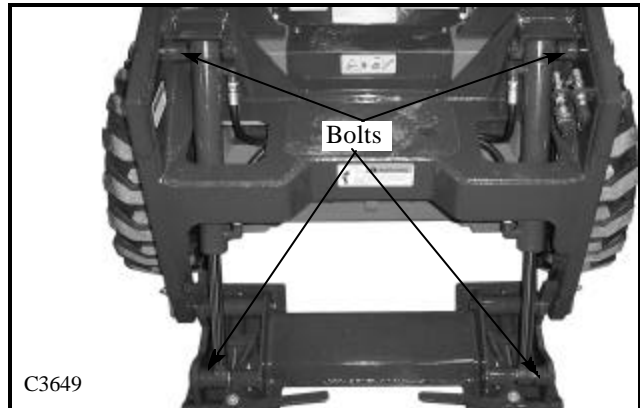

	<b>WARNING</b>
<p>Use extreme caution when checking the hydraulic system for leaks. Fluid under pressure can penetrate the skin and cause serious injury. Never tighten or repair hydraulic lines while the engine is operating.</p>	

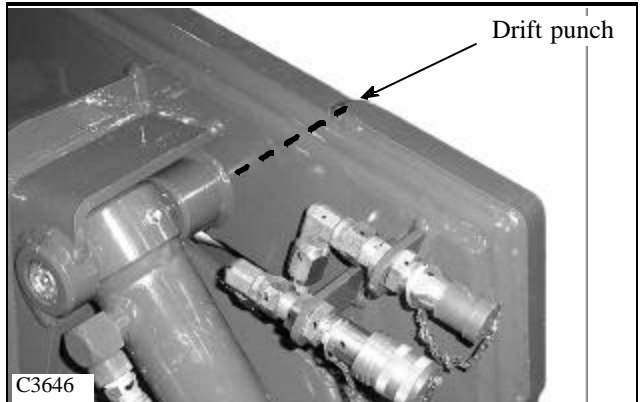
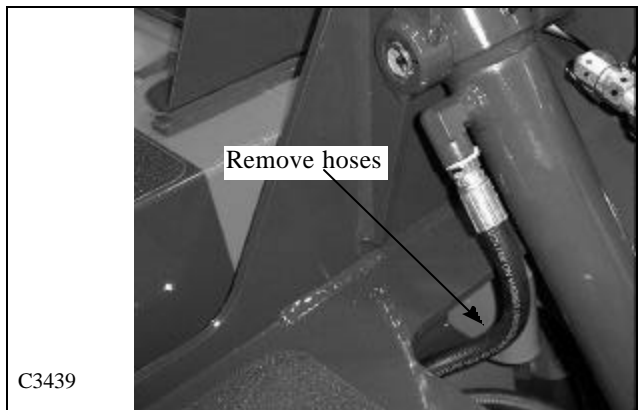



# HYDRAULIC CYLINDERS 1.4

1

## Cylinder Disassembly

Before Attempting repairs to the hydraulic cylinder, clean the body with a suitable solvent. Ensure all openings are plugged to prevent solvent from entering the cylinder.

- 1 Remove the cylinder as outlined previously.
- 2 Place the base end of the cylinder in a vise or on a pin held in the vise and support the front end of the body. Remove the plugs from the hose ports. (fig. C3725)
- 3 Loosen the gland nut from the cylinder barrel using a spanner wrench. The gland nut threads are coated with loctite bonding agent at time of assembly. It may be necessary to apply heat to the gland nut and cylinder barrel threaded area, with a torch, to ease removal. (fig. C3725)
- 4 Remove the gland nut, rod and piston seal assembly from the barrel. (fig. C3726)

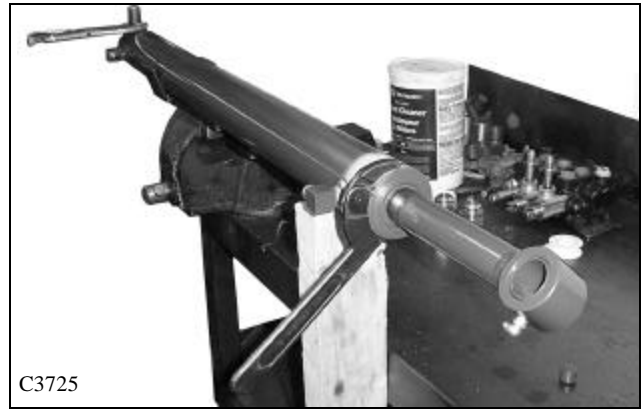

C3725



C3726

- 5 Place the cylinder rod bushing end in a vise or on a pin held in a vise and remove the lock nut from the rod. (fig. C3729)

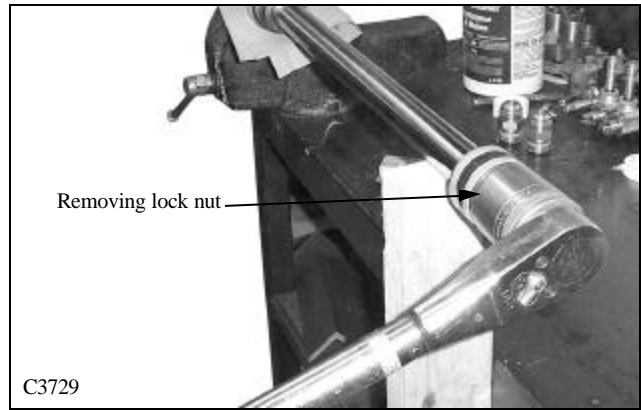

C3729

- 6 Remove the 2 piece piston assembly from the rod. (fig. C3731)
- 7 NOTE: Some piston assemblies rear piston parts are threaded onto the rod. You will need to use a spanner wrench to remove this type of rear piston.



C3731

# HYDRAULIC CYLINDERS 1.4

1

8 Depending on the design of the rear piston, non threaded type, remove and discard the o-ring seal from the end of the cylinder rod. (fig. C3732)

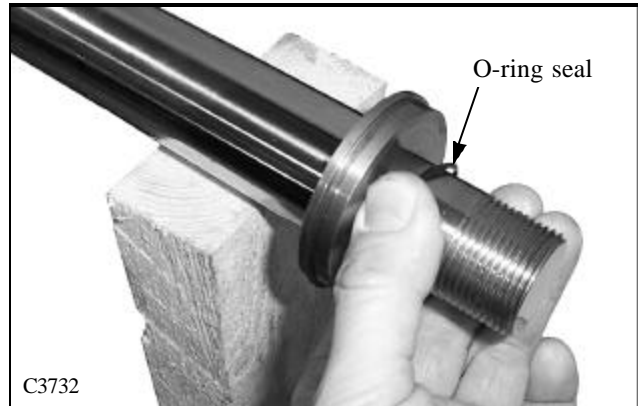

9 Remove the gland nut assembly from the cylinder rod. (fig. C3733)

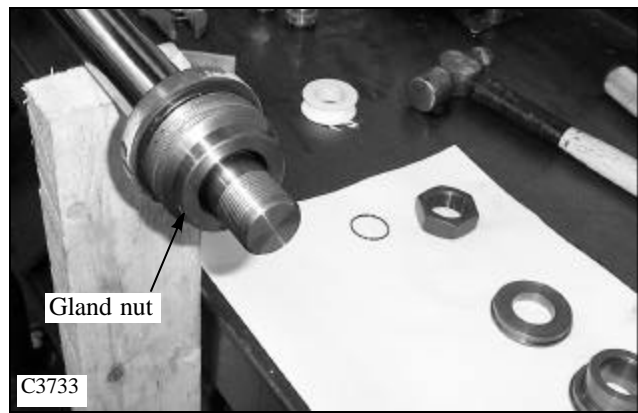

10 Remove and discard the wiper seal, rod seal and o-ring seals and teflon back up washer, (if used), from the gland nut assembly. (fig. C3734) NOTE: Some seal designs may vary from illustration

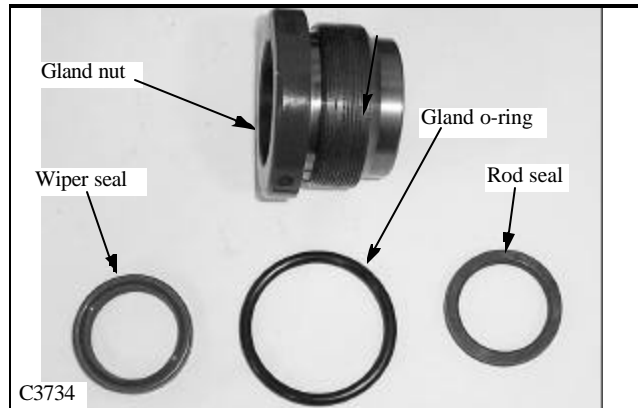

11 Remove and discard the wear rings and piston seal from the piston assembly. (fig. C3735)

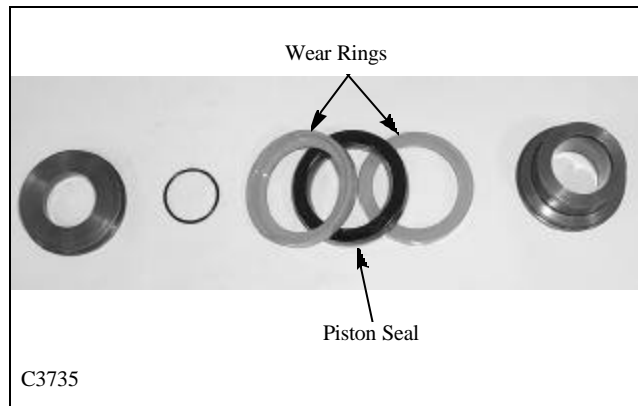

# HYDRAULIC CYLINDERS 1.4

1

## Cylinder Inspection

1 Inspect the cylinder rod for scratches, dents and other damage. Minor rod damage may be repaired using a fine abrasive. Major scratches or dents are not repairable and the rod must be replaced. The chrome surface must be intact to provide a rust resistant surface. Blemishes on the rod will damage the rod seal and wiper and will cause leaking after a short period of use.

2 Inspect the cylinder rod threads. The threads must be in good condition to withstand the high torque required to secure the piston assembly to the rod.

3 Inspect the gland nut for nicks, burrs or other damage. Minor damage may be repaired using a fine abrasive.

Smooth down edges that could damage seals and cause leakage.

4 Inspect the gland nut threads for damage.

5 Inspect the piston assembly for damage. Remove minor scratches or damage with a fine abrasive.

6 Using a suitable light, inspect the cylinder barrel bore for scratches, dents, burrs or any other damage. Replace the cylinder barrel if there is any evidence of damage.

7 Inspect the cylinder barrel threads for damage. The threads must be in good condition to withstand the high torque required to secure the gland nut assembly to the cylinder barrel.

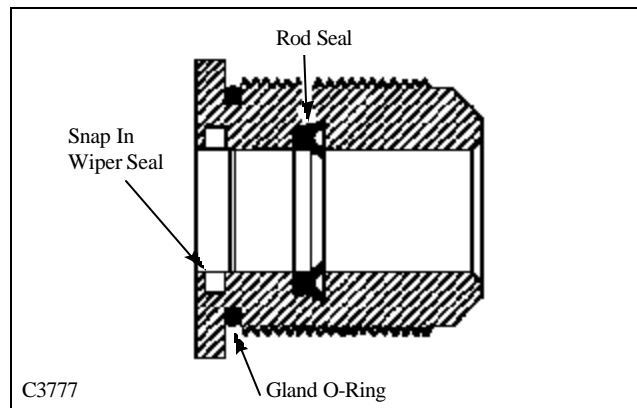
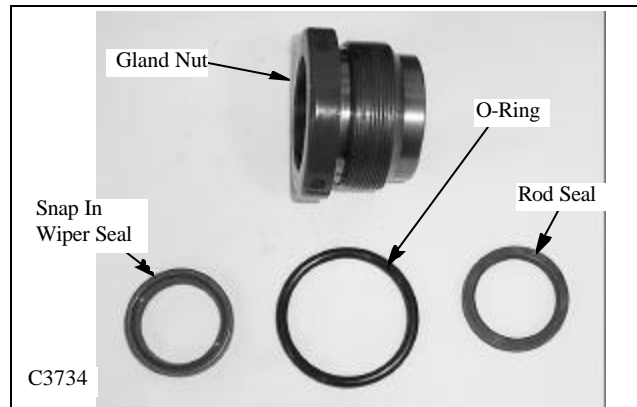

## Cylinder Assembly

1 Install a new gland nut rod seal. Form the seal into an oval shape and place it into the gland nut, with the “U” side of the seal facing the barrel end, and slip the seal into the groove. (fig. C3734)

2 Install a new wiper seal in the gland nut. (fig. C3734, C3777)

3 Install a new gland nut o-ring seal. (fig. C3734, C3777)

4 Apply system oil to the cylinder rod and assemble the gland nut assembly to the rod. (fig. C3736)



# HYDRAULIC CYLINDERS 1.4

1

5 Install a new o-ring seal on the cylinder rod (if used). Some cylinder rods are fully threaded to accommodate a threaded type rear piston part. (fig. C3737)

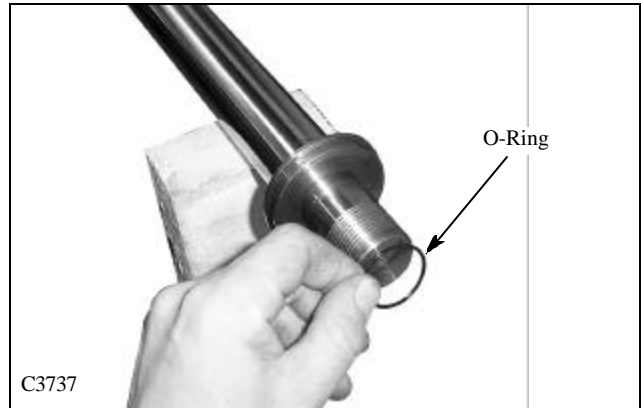

6 Install new wear rings and piston seal to the the 2 piece piston assembly. (fig. C3738)

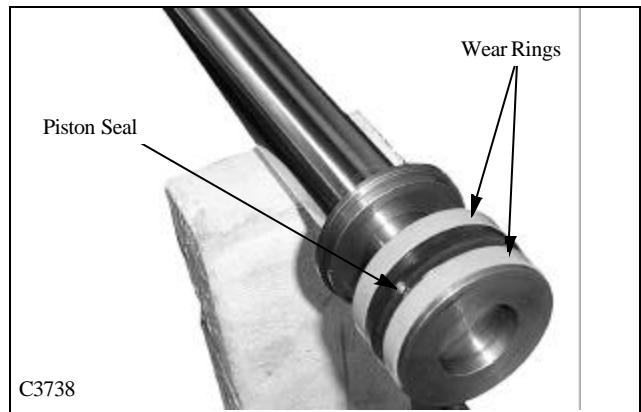

7 Install the piston assembly to the cylinder rod. Some rear piston assemblies are threaded onto the cylinder rod. Use a spanner wrench to install the rear piston part to the cylinder rod. Torque the lock nut to the rod at 250-275 ft / lbs (339-373 N.m.). (fig. C3740)

8 Make sure the inside bore of the cylinder barrel is clean. Lubricate the inside of the barrel with system oil. Do not get oil into the threaded area of the barrel.

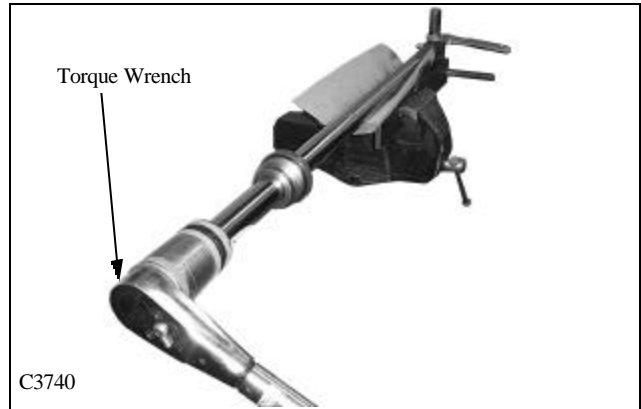

9 Lubricate the piston seal assembly with system oil and install the cylinder rod and piston assembly to the cylinder barrel. (fig. C3741)

10 Apply loctite 242 to the gland nut threads and tighten the gland nut using a spanner wrench. Tighten the gland nut as much as you can using the spanner wrench. Make sure the threaded area of the gland nut and cylinder barrel are free of oil before applying the loctite bonding adhesive.

11 Assemble the cylinder to the loader.



# HYDRAULIC OIL FILTER 1.5

## General Information

The hydraulic oil filter is located in the engine compartment, accessed by opening the rear door and lifting the engine compartment cover. The filter is mounted on the left side, on the oil reservoir.

All oil returning from the control valve is cooled and then filtered before being used up by the hydraulic system. The hydraulic oil filter is a spin on type with a 5 micron rating. The filter material is a synthetic media which features an accordion pleated design to provide maximum filtration area. Only Thomas approved filters should be used.

The filter mounting head has a built in bypass valve that diverts oil around the filter when more than 25 psi (34 nm) differential pressure is required to force oil through the filter.



C3442



C3650

## Filter Replacement

The hydraulic oil filter must be changed after the first 50 hours of operation and every 150 hours thereafter.



### WARNING

**Never repair or tighten hydraulic lines while the engine is operating or the system is under pressure.**



C1968

- 1 Lower the boom arms, shut off the engine and engage the parking brake.
- 2 Open the rear door and raise the engine compartment cover to gain access to the hydraulic filter. (fig. C3442, C3650)
- 3 Clean the area of excess dirt if necessary to prevent contaminating the new filter when installing
- 4 Remove the hydraulic oil filter using a proper sized filter wrench. Check to make sure the o-ring seal has come off with the used filter. (fig. C1968)
- 5 Lubricate the new filter seal with clean system oil.
- 6 Install the filter and fit hand tight.
- 7 After start up, check the system for oil leaks. Replenish the oil reservoir as required with API 10W30 class SJ. (fig. C3431, C1108)

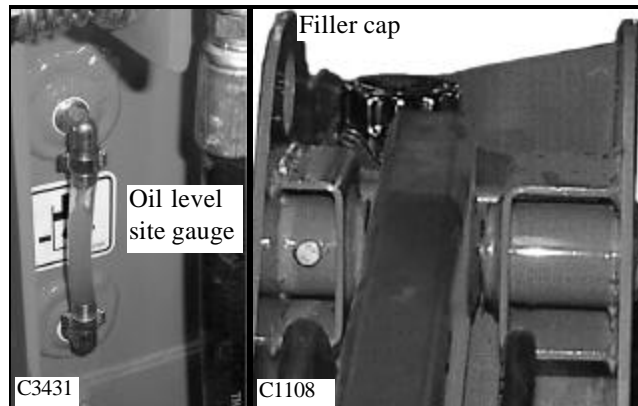

C3431

C1108

# HYDRAULIC OIL COOLER 1.6

# 1

## General Information

The hydraulic oil cooler is mounted to the inside of the rear door. (fig. C3443) Oil returning from the control valve is circulated through the oil cooler before being sent on to other parts of the hydraulic system.

An engine driven cooling fan drives air through the oil cooler when the rear door is closed.

The oil cooler is rated at 650 BTU / minute.

The oil cooler should be checked daily for dirt build up on the cooling fins. If air flow is restricted through the cooling fins, over heating of the hydraulic system may occur. Clean any dirt build up with compressed air. Flush with water if necessary. The oil cooler is surrounded by a



### WARNING

To avoid eye injury, always use safety goggles when cleaning with compressed air.

shroud. The outer edge of the shroud holds a layer of sealing foam that presses against the engine radiator when the rear door is closed. This directs the air, driven by the engine cooling fan (C3659), through the hydraulic oil cooler. The sealing foam and adjustment should be checked at every service interval. The shroud seal (C3444) to radiator adjustment can be made by loosening the upper radiator mounting brace and moving the radiator back or forward. (fig. C3660) If necessary the whole engine may need to be moved if adjustment cannot be made by moving the radiator.

## Cooler Replacement

- 1 Lower the boom arms, engage the parking brake and shut off the engine.
- 2 Open the rear door and remove the cooler shroud.
- 3 Connect a vacuum system to the oil reservoir filler spout, if available, or drain the hydraulic oil reservoir. Be prepared to contain 56 liters of fluid (14.8 gal). Use clean containers if the oil is to be reused.
- 4 Remove the cooler hoses. Plug the open hoses and cooler ports to prevent contamination.
- 5 Remove the cooler from the rear door.
- 6 Remove the fittings from the oil cooler.
- 7 Inspect the fitting o-rings for damage and replace if necessary.
- 8 Install the fittings into the new or repaired oil cooler following the torque chart on section 1.10. Be sure to support the cooler as the fittings are tightened to prevent damaging the cooler.
- 9 Replace the cooler, cooler lines and cooler shroud. Follow the torque chart on section 1.10 when tightening the hydraulic hoses.

- 10 Replenish the hydraulic fluid as required. Check for system leaks and check the fit of the shroud seal to the engine radiator. Adjust if necessary.

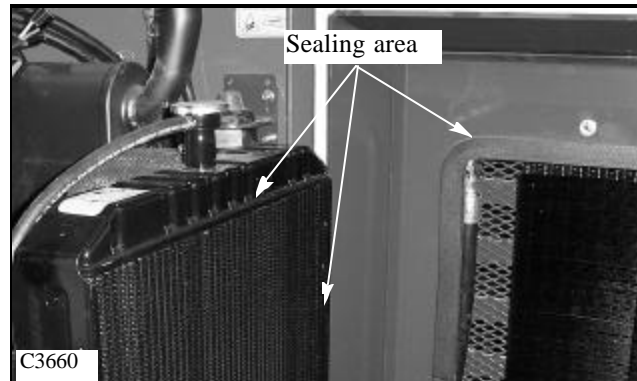
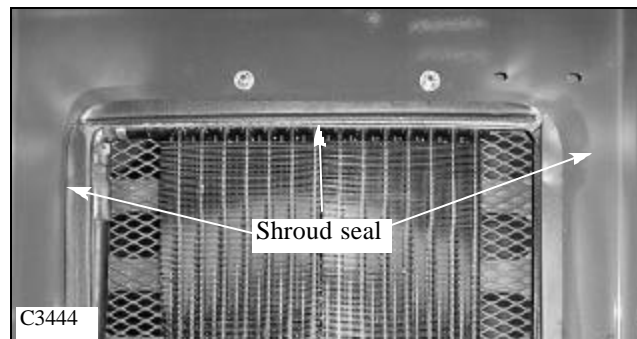
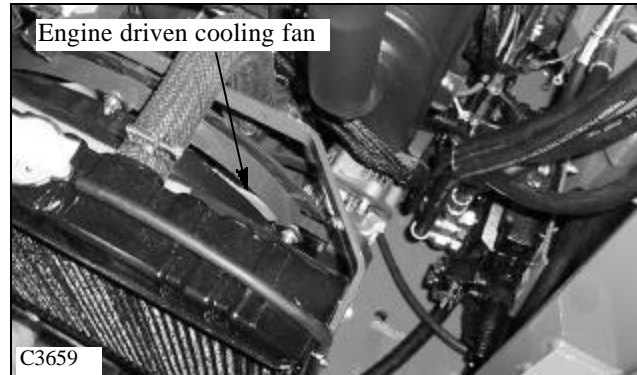

# HYDRAULIC OIL RESERVOIR 1.7

## General Information

The hydraulic oil reservoir is located at the rear of the loader on the left hand side. (fig. C3445) The reservoir is completely separated from all chain and gear drives to eliminate contamination. A magnetic drain plug is installed in the bottom of the reservoir, and a magnet is attached to the 100 micron suction filter, to assist in removing metal particles from the oil.

Oil level is checked through a site gauge located just inside the engine compartment, left hand side, on the oil reservoir. The proper fill level is marked by a line and should be checked daily. (fig. C3431)

The oil reservoir fill cap is located at the top of the reservoir. (fig. C1108) The oil fill cap assembly has a 30 micron screen to catch larger particles of contaminant before entering the reservoir, but **always use oil filtered through a 5 micron min. filter for replenishing the hydraulic reservoir.** The oil fill cap is also a reservoir vent, or breather, and contains a 10 micron filter to remove air borne particles.

## Checking The Oil Level

- 1 Check the reservoir oil level with the loader on level ground.
- 2 Lower the boom arms, retract the cylinders and engage the parking brake. Shut off the engine.
- 3 Open the rear door. (fig. C3442)
- 4 Check the oil level in the sight gauge. (fig. C3431)
- 5 If oil is visible approximately mid way in the sight gauge, the level is correct. The correct level is marked with a line from the factory.

## Adding Oil

- 1 Remove the bolt, or lock, on the reservoir filler cap.
- 2 Open the filler cap. (fig. C1108)
- 3 Inspect the filler screen in the filler neck for damage. If the filler screen is damaged, replace it.
- 4 Using a clean container, add 10W30 API class SJ.
- 5 Replace the filler cap and replace the bolt, or padlock, in the cap to prevent vandalism.

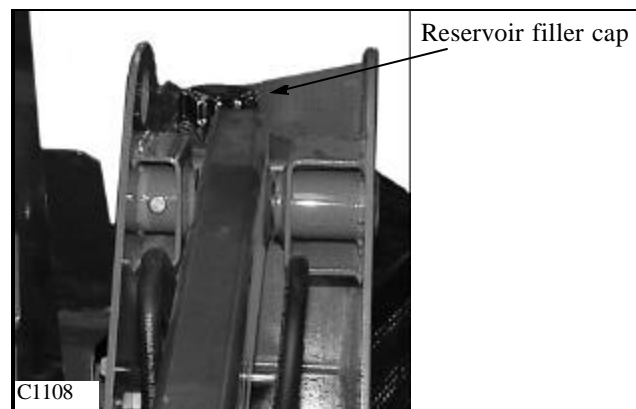
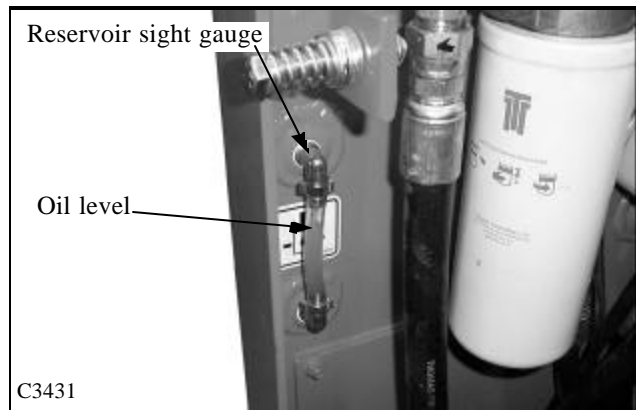
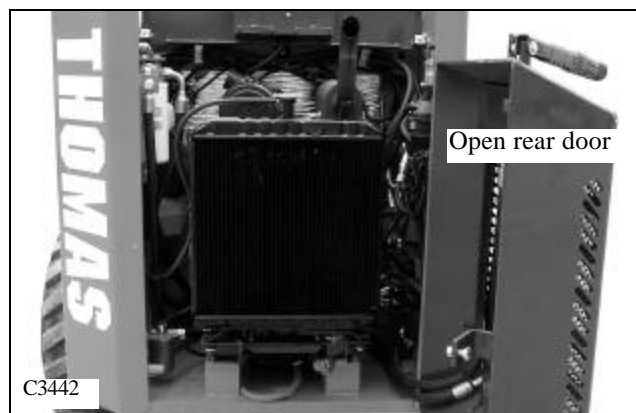
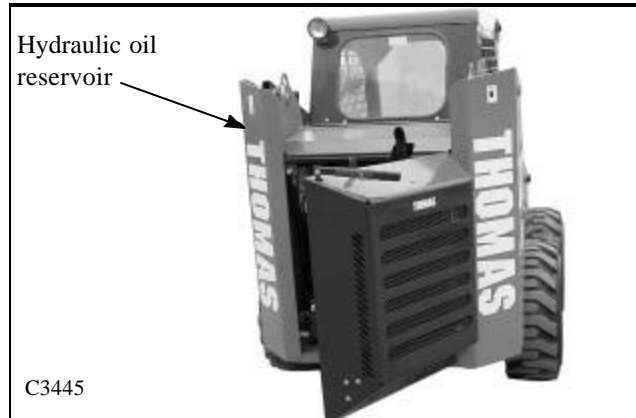

# 1

## HYDRAULIC OIL RESERVOIR 1.7

### Servicing The Oil Reservoir

Change the hydraulic oil, change the suction screen element and clean the magnet in the tank after every 1000 operating hours or if the oil has become contaminated or after any major hydrostatic drive system repair.

- 1 Lower the boom arms, shut off the engine and engage the parking brake.
- 2 Remove the magnetic drain plug located at the bottom of the hydraulic oil reservoir. Clean any metal particles that may be attached to the magnet. (fig. C3661) Have containers ready to hold approximately 14.8 gallons (56 £) of fluid. Replace the drain plug using teflon sealing tape or liquid type sealant on the plug threads.
- 3 Access the suction screen element in the hydraulic reservoir by removing the inspection cover on the reservoir, located in the engine compartment. (fig. C3662) Clean the excess silicone from the cover and reservoir.

**NOTE:** You may need to remove the hydraulic oil filter, or possibly some hoses, to gain access to the inspection cover nuts.

- 4 Remove the suction screen element from the reservoir by turning counter clockwise. (fig. C3663, C3664)
- 5 Remove and clean the magnet attached to the suction element. (fig. C3663)
- 6 Install the magnet onto a new suction element and install the suction element.
- 7 Apply silicone around the inspection hole and install the inspection cover to the reservoir. Do not over tighten the mounting nuts. Maximum torque is 11 ft / lbs (15 N.m.).
- 8 Fill the reservoir to the proper level with 10W30 API classification SJ oil, approximately 14.8 gallons or 56 liters.

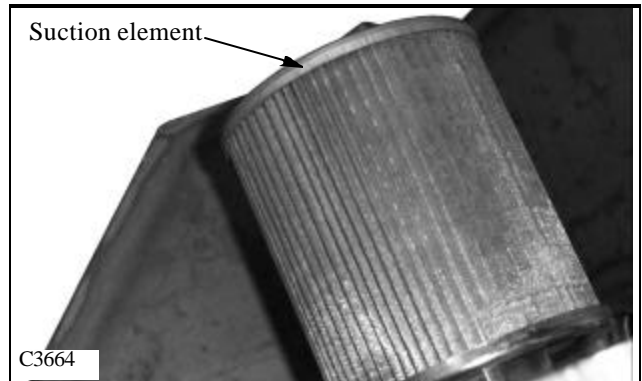
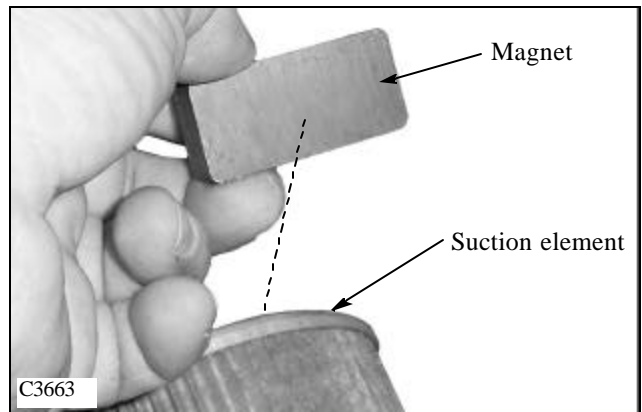
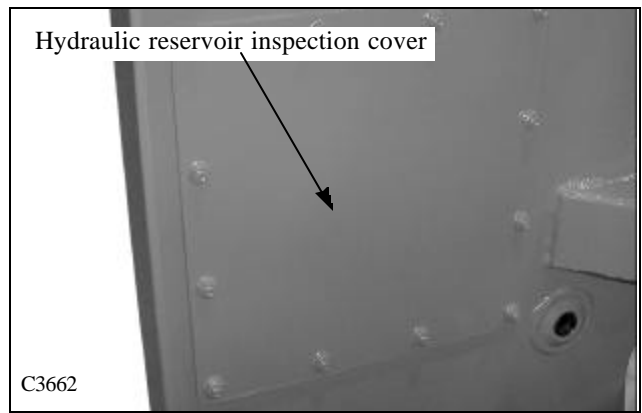
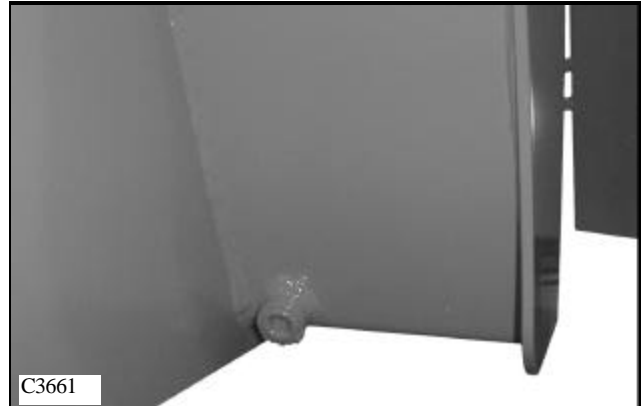



# TROUBLE SHOOTING 1.8



Problem	Cause	Corrective Action	Section
Loss of hydraulic power (no flow from the gear pump).	Reservoir low on oil.	Check for leaks. Fill the reservoir to the proper level.	1.8
	Universal joint between engine and tandem pump failure.	Inspect and replace the damaged parts as required. Check for proper alignment.	7.11
	Gear pump not functioning.	Inspect and replace damaged parts.	1.4 / 2.9
	Splined coupling failure in the hydrostatic pump	See the Sauer Sundstrand Repair Manual BLN 9992.	2.10
Loss of hydraulic power (full flow from gear pump).	Electrical failure.	Check fuse, switches and wiring.	8
	Auxiliary hydraulics engaged.	Disengage the switch.	4.9
	Relief valve failure or out of adjustment.	Check pressure. Adjust or repair as required.	1.4
	Control locks engaged	Check fuse, safety switches and valve lock parts.	1.4 / 8
Hydraulic action jerky.	Reservoir low on oil.	Check for leaks. Fill the reservoir to the proper level.	1.8
	Control linkages loose or worn.	Inspect, adjust or replace parts.	4
	Air in hydraulic system.	Check for leaks between the oil reservoir and pump.	
	Load check valve not functioning.	Inspect and replace damaged parts.	1.4
	Control valve spool spring return mechanism not functioning	Inspect and replace damaged parts.	1.4
Boom raises slowly at full RPM	Reservoir low on oil.	Check for leaks. Fill the reservoir to the proper level.	1.8
	Control linkages loose or worn.	Inspect, adjust or replace parts.	4
	Auxiliary hydraulics engaged.	Disengage the switch.	4.9
	Lifting more than rated capacity.	Reduce the load.	
	Engine RPM too low.	Check engine RPM and reset.	7.11
	Relief valve failure or out of adjustment.	Check pressure. Adjust or repair as required.	1.4
	Cylinder seal(s) failure.	Check seals.	1.5
	Internal leakage in the control valve.	Inspect the control valve and repair as required.	1.4
Hydraulic cylinders will not support a load. (leak down)	Control valve spools not centering.	Check control linkage and control valve spool spring centering devise.	1.4 / 4
	External leak between control valve and cylinders	Inspect and repair.	
	Cylinder seal(s) failure	Check seals.	1.5
	Load check valve not functioning.	Inspect and replace damaged parts.	1.4

# TROUBLE SHOOTING 1.8

1

Problem	Cause	Corrective Action	Section
Hydraulic oil overheating.	Reservoir low on oil.	Check for leaks and replenish as required.	1.8
	Oil cooler plugged or dirty.	Clean the cooling fins.	1.7
	Auxiliary hydraulics engaged.	Disengage.	4.9
	Cooling fan damaged or inoperative	Check fan and drive belt	1.7
	Engine RPM too low.	Check engine RPM and reset.	7.11
	Temperature sender defective.	Replace.	8
	Relief valve failure or out of adjustment.	Check pressure, adjust or replace.	1.4
	Wrong type of hydraulic fluid.	Replace.	1.8

## TORQUE CHART 1.9

**Torque Chart** NOTE: all torques are in ft / lbs. (Multiply by 1.36 = N.m.)

HOSE SIZE	37° JIC FITTINGS	HOSE SIZE	ORB FITTINGS
1/4	9 to 10	1/4	14 to 16
5/16	15 to 16	5/16	18 to 20
3/8	20 to 22	3/8	24 to 26
1/2	30 to 33	1/2	50 to 60
5/8	40 to 44	5/8	72 to 80
3/4	70 to 77	3/4	125 to 135
7/8	82 to 90	7/8	160 to 180
1	55 to 60	1	200 to 220
1 1/4	120 to 132	1 1/4	210 to 280
1 1/2	131 to 144	1 1/2	270 to 360
2	300 to 330		

The following torque specifications are for steel ORB fittings into aluminum.			
HOSE SIZE	ORB FITTINGS	HOSE SIZE	ORB FITTINGS
1/4	5 to 7	3/4	40 to 45
5/16	8 to 10	7/8	50 to 55
3/8	10 to 12	1	90 to 99
1/2	21 to 24	1 1/4	80to 90
5/8	27 to 30		

# CONVERSION CHART 1.10

## CONVERSION FACTORS

### Metric To U.S.



	MULTIPLY	BY	TO OBTAIN
Area:	sq. meter	10.763 91	square foot
	hectare	2.471 05	acre
Force:	newton	3.596 942	ounce force
	newton	0.224 809	pound force
Length:	millimeter	0.039 370	inch
	meter	3.280 840	foot
	kilometer	0.621 371	mile
Mass:	kilogram	2.204 622	pound
Mass/Area:	kilogram/hectare	0.000466	ton/acre
Mass/Energy:	gr/kW/hr.	0.001 644	lbs/hp/hr.
Mass/Volume:	kg/cubic meter	1.685 555	lb/cubic yd.
Power:	kilowatt	1.341 02	horsepower
Pressure:	kilopascal	0.145 038	lb/sq.inch
	bar	14.50385	lb/sq.inch
Temperature:	degree C	$1.8 \times C + 32$	degree F
Torque:	newton meter	8.850 748	lb/inch
	newton meter	0.737 562	lb/foot
Velocity:	kilometer/hr.	0.621 371	miles/hr.
Volume:	cubic centimeter	0.061 024	cubic inch
	cubic meter	35.314 66	cubic foot
	cubic meter	1.307 950	cubic yd.
	millimeter	0.033 814	ounce (US fluid)
	litre	1.056 814	quart (US liquid)
	litre	0.879 877	quart (Imperial)
	litre	0.264 172	gallon (US liquid)
	litre	0.219 969	gallon (Imperial)
Volume/Time:	litre/min.	0.264 172	gallon/min. (US liquid)
	litre/min.	0.219 969	gallon/min. (Imperial)

# CONVERSION CHART 1.10

## CONVERSION FACTORS

### U.S. To Metric

	MULTIPLY	BY	TO OBTAIN
Area:	sq. foot	0.092 903	square meter
	acre	0.404 686	hectare
Force:	ounce force	0.278 014	newton
	pound force	4.448 222	newton
Length:	inch	25.4	millimeter
	foot	0.304 8	meter
	mile	1.609 344	kilometer
Mass:	pound	0.453 592	kilogram
	ounce	28.35	gram
Mass/Area:	ton/acre	2241 702	kilogram/hectare
Mass/Energy:	lb/hp/hr	608.277 4	gr/kW/hr
Mass/Volume:	lb/cubic yd.	0.5930276	kg/cubic meter
Power:	horsepower	0.745 700	kilowatt
Pressure:	lbs/sq.in.	6.894 757	kilopascal
	lbs/sq.in.	0.069	bar
	lbs/sq.in.	0.070 303	kg/sq.cm
Temperature:	degree F	1.8 F - 32	degree C
Torque:	pound/inch	0.112 985	newton meter
	pound/foot	1.355 818	newton meter
Velocity:	miles/hr.	1.609 344	kilometer/hr.
Volume:	cubic inch	16.387 06	cubic centimeter
	cubic foot	0.028 317	cubic meter
	cubic yard	0.764 555	cubic meter
	ounce (U.S. fluid)	29.573 53	milliliter
	quart (U.S. liquid)	0.946 353	litre
	quart (Imperial)	1.136 523	litre
	gallon (U.S.)	3.785 412	litre
	gallons (Imperial)	4.546 092	litre
Volume/Time:	gallon/min.	3.785 412	litre/min.

---

# NOTES

---

1

