

SECTION 3 FINAL DRIVE

Specifications & Maintenance	3.1
Chart	pg. 3-2
Lubrication	3.2
Checking the Oil	pg. 3-3
Adding Oil	pg. 3-3
Changing the Oil	pg. 3-3
Drive Chain	3.3
Inspection	pg. 3-4
Removal	pg. 3-5
Installation	pg. 3-6
Drive Motor Sprocket	3.4
Replacement	pg. 3-7
Axle Assembly	3.5
Illustration	pg. 3-8
Removal	pg. 3-9
Inspection	pg. 3-10
Installation	pg. 3-11 ~ 3-13
Stud Replacement	pg. 3-14
Trouble Shooting	3.6
Chart	pg. 3-15



SPECIFICATIONS & MAINTENANCE 3.1

Specifications

Chain Size ANSI 100
Approved Chain Manufacturer Tsubaki
Lubricating Oil 10W30 API Classification SJ
Oil Capacity (each) 17 Liters. (4.5 gal)
Torque Specifications:
Motor Sprocket Bolt 25 lbs /ft (34 nm)
Wheel Nuts..... 100 - 110 lbs /ft (135 - 149 nm)
Tire Pressure..... 50 psi (345 Kpa)



Maintenance	Initial Check (hrs)	Check Every (hrs)
--------------------	----------------------------	--------------------------

Tire Pressure	8	8
Wheel Nut Torque	8	8
Lubrication Oil	50	150 (*)
Motor Mounting Nuts	50	150
Axle Bearing Pre-load	50	150

(*) Change every 1000 hours.

LUBRICATION 3.2

Checking The Oil Level

The loader has 2 independent final drive housings. When checking the oil level ensure the loader is on a level surface.

- 1 Remove the top (upper) check plug located between the 2 tires at the side of the loader. (fig. C3496)
The oil level should be at the top of the check hole with a little to trickle out.



WARNING

Never work under a raised boom arm without the boom supports engaged and the engine shut off.

Adding Oil

Oil should be added with the loader on a level surface.

- 1 Remove any attachment, raise the boom arms and engage the boom support pins. Shut off the engine.
- 2 Remove the oil level check plug as outlined above. (fig. C3496)
- 3 Remove the seat plate and front bulkhead assembly.
- 4 Remove the vented filler plug. (fig. C3845)
- 5 Add 10W30 API classification SE/CD oil until it begins to flow out the upper check hole. Total final drive housing capacity per side is 17 liters (4.5 gal).
- 6 Replace all plugs.

IMPORTANT

Check the final drives closely for damaged seals or other leaks if the oil level is excessively low.

Changing The Oil

Ensure the loader is on a level surface before changing the oil.

- 1 Shut off the engine.
- 2 Slide a drain pan under one of the lower drain plugs located at the side of the loader, between the wheels. (fig. C3496) Be prepared to contain 17 liters (4.5 gal) of oil.
- 3 Remove the drain plug. Allow the oil to drip completely out of the final drive housing. Replace the drain plug. Dispose of the waste oil in an environmentally friendly manner. If the oil is contaminated, remove the side inspection cover to flush the housing. (fig. C3521)
- 4 Replenish the oil as outlined above in Adding Oil with 10W30 API classification SJ oil.

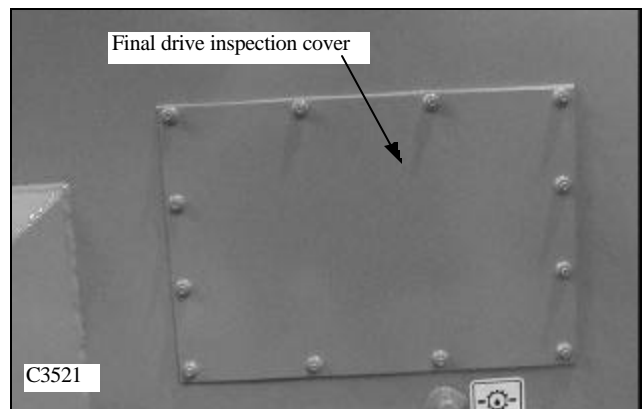
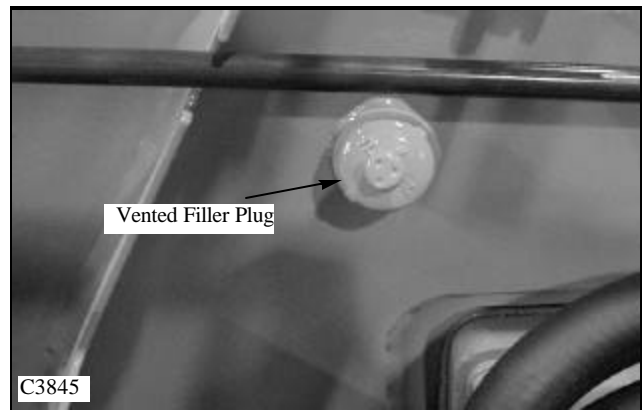
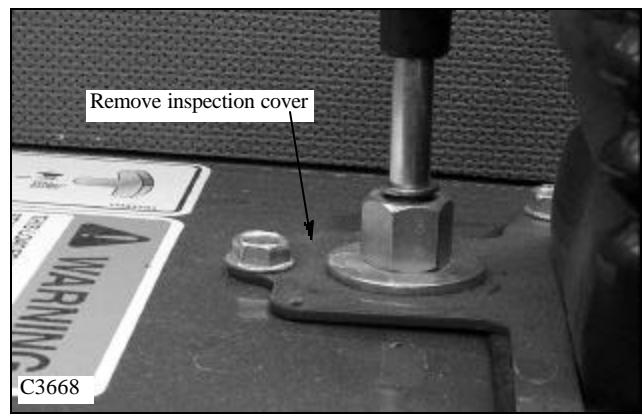
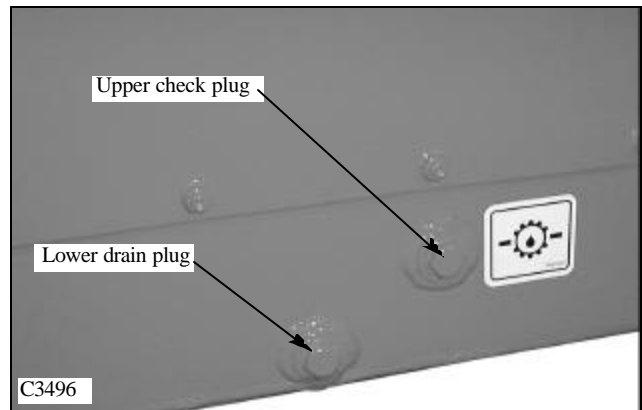

DRIVE CHAIN 3.3

Chain Inspection

The drive chains should be inspected for wear or damage after the first 50 hours of operation and every 150 hours thereafter, or at any time the final drive inspection cover is removed. If the chain shows any sign of wear or damage replace it. (fig. C3769) Inspect as follows:

1. Inspect the chain for excessive roller wear
2. Inspect the chain for excessive wear on the link plates
3. Inspect the connection link cotter pins for wear or damage caused by interference.
4. Check the sprocket for excessive wear or damage such as broken teeth or sharp/rounded teeth.
5. If the chain is removed from the loader, check for stiffness caused by wear between the pins and bushings.
6. If the chain is removed from the loader, check that when laid out it runs straight and not to one side, indicating misalignment.

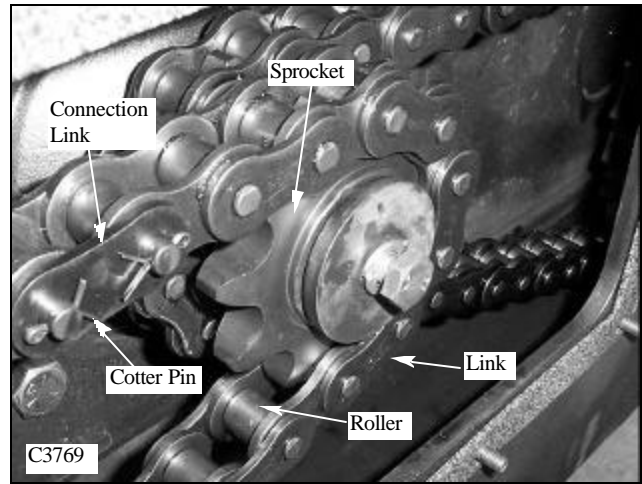

3

DRIVE CHAIN 3.3

Chain Removal

- 1 Remove any attachment, raise the boom arms and engage the boom support pins. Shut off the engine.
- 2 Block the loader securely with all 4 wheels clear of the ground.
- 3 Remove the wheels from the side of the loader the chain is to be removed.
- 4 Clean the excess dirt from the final drive housing. Drain the plug area and the inspection cover area located between the 2 axle towers. (fig. C3524)
- 5 Remove the lower drain plug and drain the oil. Refer to Section 3.2 page 3-3.
- 6 Remove the final drive inspection cover. (fig. C3524)
- 7 Rotate the chains, if necessary, to locate the master connecting link by starting the engine and engaging the steering control. Be sure the loader is securely raised clear of the ground. Shut off the engine.

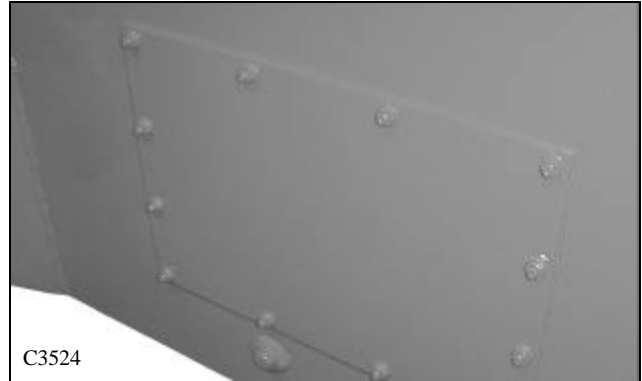

- 8 Remove the cotter pins from the master connecting link and remove the connecting link. (fig. C3769) The connecting link is a press fit type and will need to be supported as you drive the link pins through the link plate.

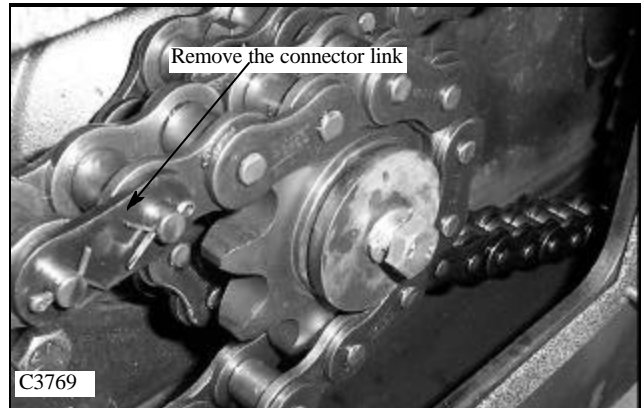

- 9 Remove the front or rear chain from the housing by turning the axles by hand and pulling the slack chain out the inspection cover area. (fig. C3812)

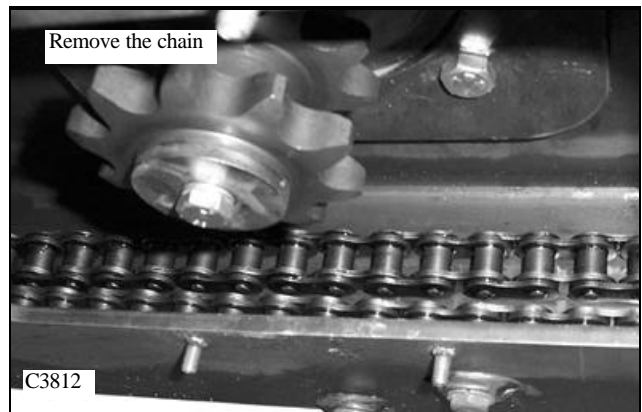

DRIVE CHAIN 3.3

Chain Installation

1 Install the wrapped chain into the final drive housing. (fig. C3812)

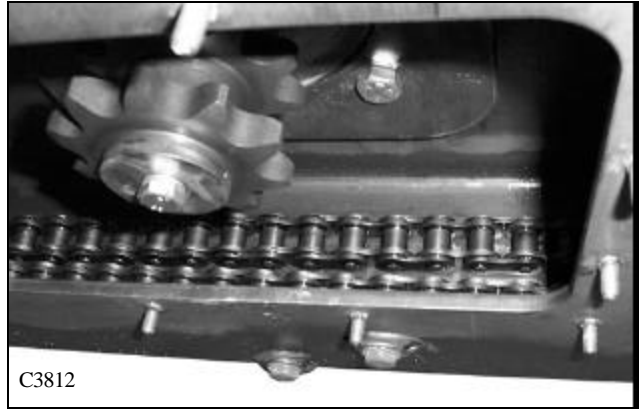

C3812

2 Place one end of the front chain over the top of the front axle sprocket. Rotate the axle and bring the chain along the bottom of the final drive housing to approximately the center. (fig. C3809) Wrap the other end of the chain around the motor sprocket teeth closest to the motor.



C3809

3 Place the ends together and install the new connecting link so that the cotter pins face away from the inspection cover. (fig. C3810). Bend the ends of the cotter pins at least 90 degrees.



C3810

4 Wrap the rear chain over the rear axle sprocket. Rotate the axle and chain around the bottom of the final drive housing and around the bottom of the motor sprocket closest to the inspection cover opening until the ends of the chain meet together.

5 Install a new connecting link. (fig. C3522) Place the connecting link into the chain so the cotter pins face the inspection cover hole. Bend the ends of the cotter pins at least 90° apart.

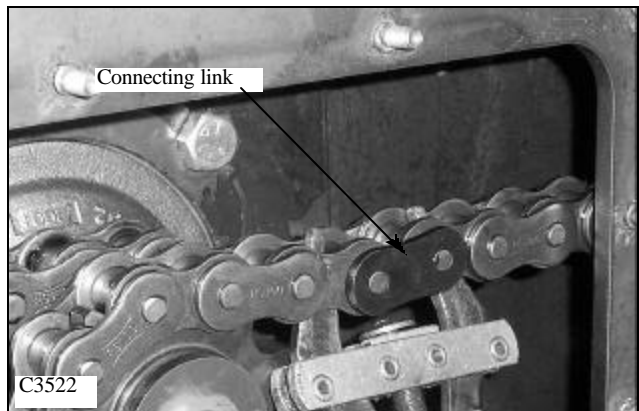

C3522

6 Replace the inspection cover using the gasket. Do not over tighten the inspection cover nuts. 11 lbs / ft maximum. (15.0 nm)

7 Replace the wheels and torque the wheel nuts to 100 to 110 lbs/ft. (136 to 149 nm).

3

DRIVE MOTOR SPROCKET 3.4

Replacement

The torque motor drive sprocket can be removed from the loader without removing the drive motor from the final drive housing.

1 Place the loader on a level surface, engage the parking brake and shut off the engine.

2 Raise the loader securely from the ground and remove the wheels on the side to be worked on.

3 Remove the inspection cover located between the axle assemblies. (fig. C3521)

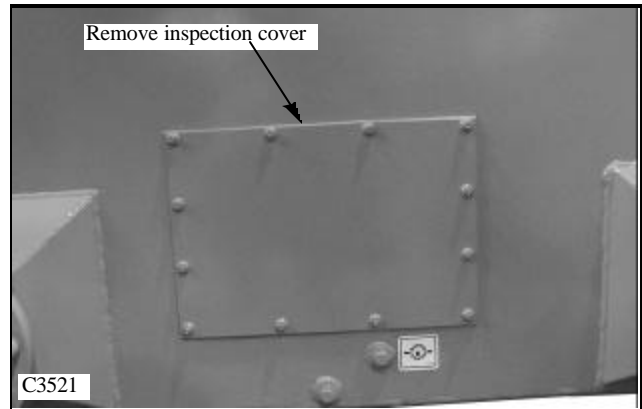

4 Remove the connector link from the front and rear chains. (fig. C3804)

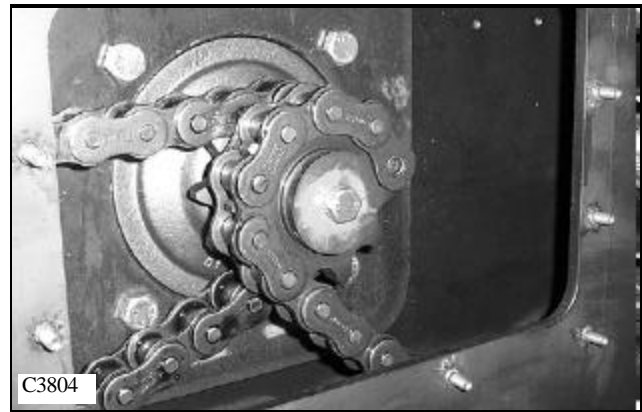

5 Remove the bolt retaining the drive sprocket to the drive motor. (fig. C3493)

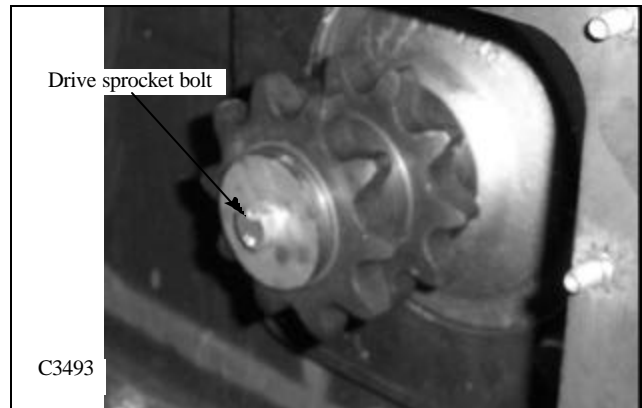

6 Slide the sprocket off the drive motor shaft. (fig. C3493 & C3802)

7 Replace the drive sprocket in the reverse order above. Apply Loctite 242 (blue) to the drive sprocket bolt and torque the bolt to 40 lbs / ft (54 Nm)



AXLE ASSEMBLY 3.5

3

Axle Assembly

C3235

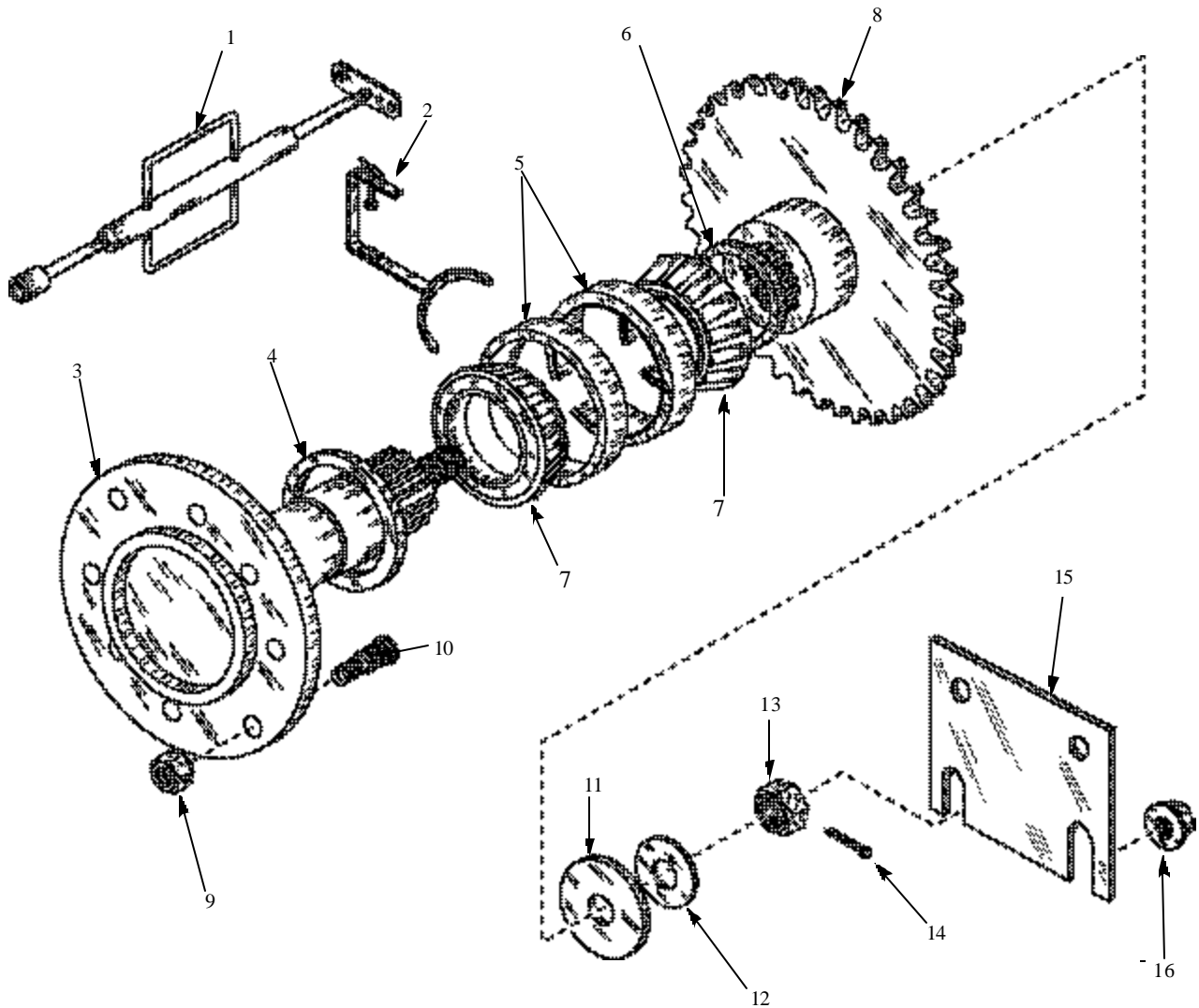

- | | |
|-------------------------------|------------------------|
| 1. Axle Puller | 10. Wheel Stud |
| 2. Seal Installation Tool (2) | 11. Plate, Axle Washer |
| 3. Axle Ass'y | 12. Washer, Axle |
| 4. Seal | 13. Castle Nut |
| 5. Bearing, Cup | 14. Cotter Pin |
| 6. Plate, Axle Spacer | 15. Sheet, Rear Cap |
| 7. Bearing, Cone | 16. Nut, Hex Flange |
| 8. Sprocket | |
| 9. Wheel Nut | |

AXLE ASSEMBLY 3.5

Axle Removal

- 1 Remove any attachment, raise the boom arms and engage the boom support pins. Shut off the engine.
- 2 Block the loader securely with all 4 wheels clear of the ground.
- 3 Remove the wheels from the side of the loader the chain is to be removed.
- 4 Clean the excess dirt from the final drive housing drain plug area and the inspection cover area located between the 2 axle towers.
- 5 Drain the lubricating oil from the final drive housing. Refer to Section 3.2 page 3-3.
- 6 Remove the final drive inspection cover located between the 2 axles.
- 7 Remove the drive chain from the sprocket of the axle being replaced. Refer to Section 3.3 page 3-6.
- 8 **FRONT AXLE:** Remove the foot pedal assembly if so equipped. Refer to Section 4.
- 9 Remove the inner axle cover plate from the final drive housing. (fig. C3811)
- 10 **REAR AXLE:** Remove the inner axle cover plate from the final drive housing.
- 11 Remove the split pin from the castle nut on the end of the axle. (fig. C3673)

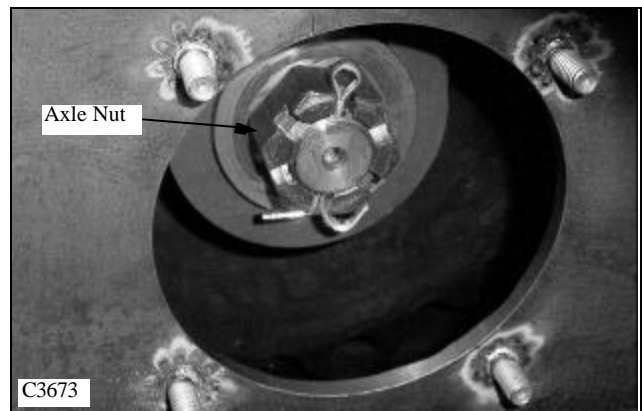
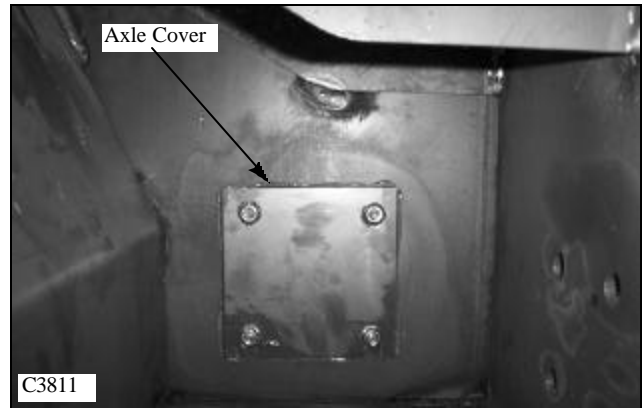

- 12 The axle may be held stationary by inserting a bar between the wheel studs.

- 13 Remove the rear castle nut and axle washer. (fig. C3674)



AXLE ASSEMBLY 3.5

- 14 Attach a special axle puller tool, Thomas P/N 957372, to the axle flange wheel studs using the wheel nuts that are on the loader. (fig. C3807)
- 15 Using the slide hammer action of the special puller, remove the axle. The rear bearing and axle sprocket will remain in the final drive housing.
- 16 Remove the axle sprocket and bearing from the final drive housing through the inspection cover area.



- 17 Using a bearing puller, remove the bearing still pressed in place on the axle. (fig. C3842, C3669)
- 18 Remove and discard the axle oil seal.



Inspection

- 1 Inspect the seal surface area for scarring, pitting or nicks. Minor scratches may be removed using fine emery cloth. Replace the axle if worn excessively.
- 2 Inspect the axle threads for damage. Replace axle if the threads are non serviceable.
- 3 Inspect axle spline for wear and replace if necessary.
- 4 Replace any axle studs as required (page 3-13)
- 5 Inspect the axle sprocket for abnormal tooth wear and inspect sprocket spline for wear. Replace the sprocket if necessary.
- 6 Inspect the bearing races in the final drive housing. Replace them if necessary using a brass drift punch and hammer. Cooling the replacement races in a freezer will aid in using this procedure.
- 7 Replace the bearings if new races are installed or if they are pitted or damaged.

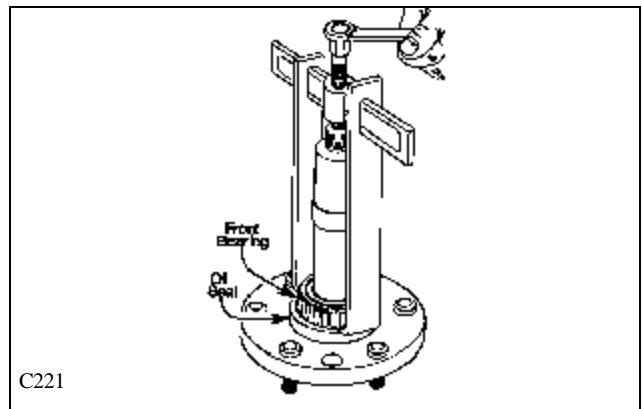

3

AXLE ASSEMBLY 3.5

Axle Installation

- 1 Check the axle seal surface area for damage. Minor scratches may be repaired using fine emery cloth.
- 2 Inspect the axle threads for damage. Replace axle if the threads are non serviceable.(fig. C3799)
- 3 Inspect the splined teeth for wear. Replace the axle if the splined teeth do not fit tightly into the sprocket spline.
- 4 Replace any axle studs as required.
- 5 Lubricate the axle oil seal with light grease.
- 6 Install the seal onto the axle. The seal part number stamping must face the flange side of the axle. (fig. C3699)
- 7 Using a press, install the front, or outer, bearing onto the axle. Be sure to support the axle up off the wheel studs to prevent damaging the wheel studs. (fig. C3800)

8 Place the front axle sprocket into the final drive housing with the hub facing toward the bearing race area. (outside) Note: The rear axle hub faces inside.

9 Apply gasket sealant to the outer edge of the final ass'y oil seal surface. (fig. C3800) Take care, make sure none gets on the bearing surface.

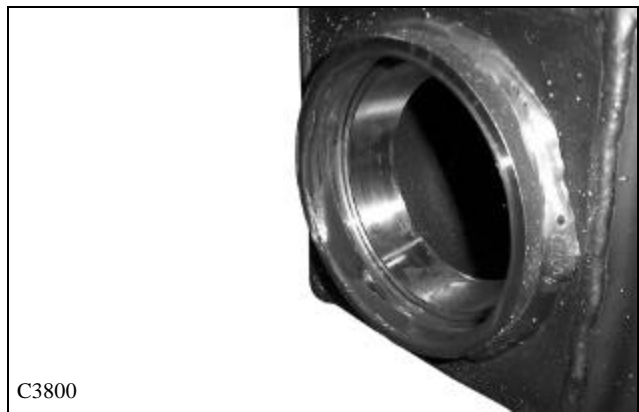

AXLE ASSEMBLY 3.5

10 Guide the axle into the final drive housing.

11 Place 2 seal installation tools, Thomas P/N 958674, equally spaced around the axle flange, behind the seal. (fig. C3671). This special tool must be used to properly locate the seal into the final drive housing.



12 Place the rear (inside) axle bearing onto the axle. (fig. C3813 & fig. C3814)

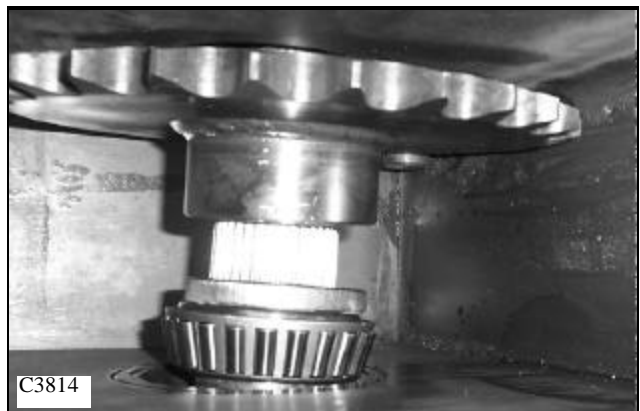

13 Start the axle into the drive sprocket. Place the small axle washer and castle nut onto the threaded end of the axle. (fig. C3815)

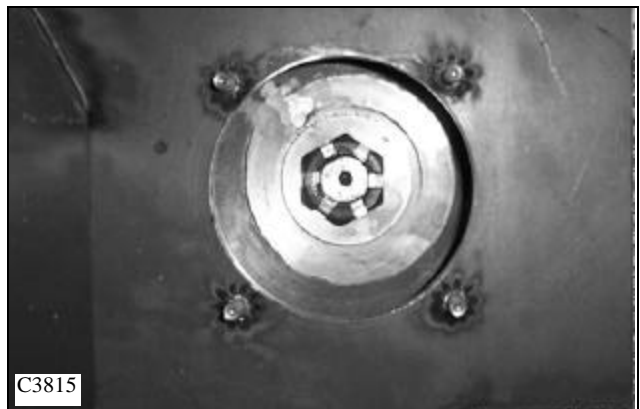

AXLE ASSEMBLY 3.5

14 Tighten the castle nut and guide the axle into the final drive housing as straight as possible to prevent damaging the seal. Tap the axle flange with a hammer if necessary to assist the installation.

As the castle nut is being tightened the rear (inside) bearing is being pressed into place and the axle oil seal is simultaneously pulled into the proper location into the final drive housing.

15 When the castle nut will not turn on any further tap the face of the flange with a hammer to ensure the seal and bearing has seated into place.

16 Remove the castle nut, remove the small washer and add the large axle washer..

17 Install the axle washer and castle nut. Tighten the castle nut to remove all axle bearing end play. (Zero pre-load) Continue tightening until the split pin hole in the axle will align with the castle nut.

18 Install the split pin. Bend the end of the split pin straight back against the axle washer.

19 Install the axle cover using silicone to seal the matting surfaces. Do not over tighten the retaining nuts. 11 lbs/ft maximum. (15 nm)

20 Install the drive chain. Refer to Section 3.3 page 3-7.

21 Fill the final drive housing to the correct level using 10W30 API classification SJ oil. Refer to Section 3.2 page 3-3 for procedure.

22 Install the inspection cover using silicone to seal the matting surfaces. Do not over tighten the retaining nuts. 11 lbs/ft maximum. (15 nm)

23 Install the wheels. Torque the wheel nuts to 100 to 110 lbs/ft. (135 to 149 nm).

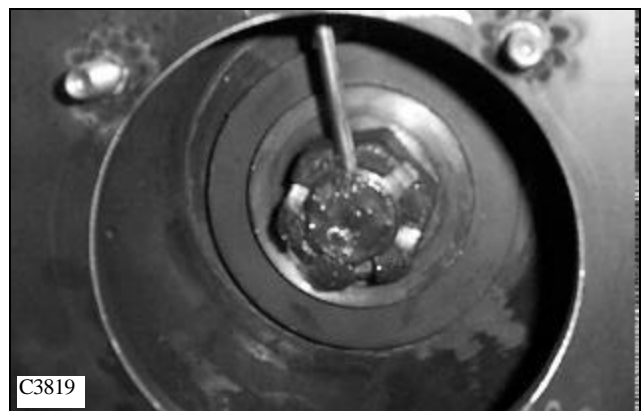
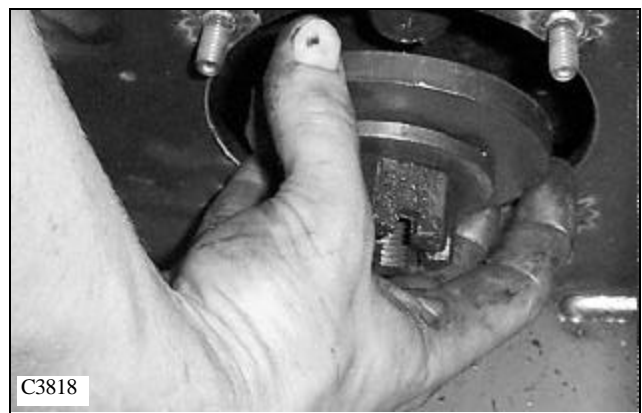
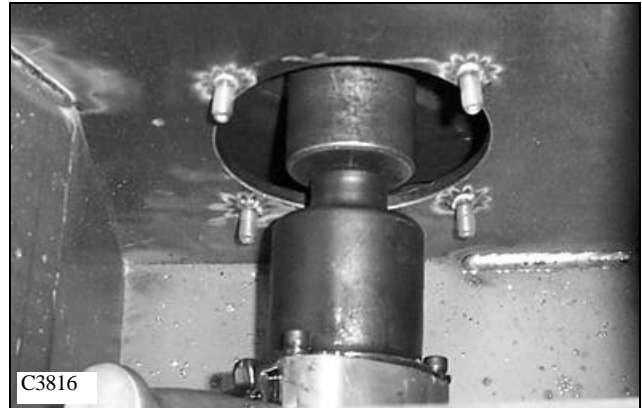

AXLE ASSEMBLY 3.5

Axle Stud Replacement

- 1 Remove any attachment, raise the boom arms and engage the boom locks.
- 2 Raise and block. Clear the side of the loader the wheel studs are to be changed on.
- 3 Remove the wheel the studs are to be replaced on.
- 4 Strike the stud with a hammer to remove from the axle flange. (fig. C3820)
- 5 Place a new stud in position behind the axle flange. Line up the splines on the stud with the splines cut into the axle flange. (fig. C3822)
- 6 Put a few drops of light oil on the stud spline. (fig. C3823)
- 7 Place a wheel nut inverted on the stud and use it to draw the stud into place in the axle flange as you tighten it, (fig. C3824 & C3821) while tapping end of stud with hammer.
- 8 Remove the wheel nut and discard. Replace with new wheel nut. (fig. C3497)
- 9 Replace the wheel and torque the wheel nuts to 100 to 110 lbs/ft. (135 to 149 nm)



IMPORTANT

Torque the wheel nuts daily to prevent stud and/or wheel damage.



TROUBLE SHOOTING 3.6

Problem	Cause	Corrective Action	Section
Final drive noisy.	No lubricating oil.	Check oil level. Add 10W30 SE/CD oil to correct level.	3.2
	Axle has too much end play. (Bearing pre-load)	Check and adjust the bearing pre-load on the axle bearings	3.6
No drive on one side.	Drive chain failure.	Inspect the drive chain and connecting link. Replace damaged parts.	3.3
	Drive motor sprocket failure	Inspect the drive sprocket and splines. Replace parts as required.	3.5 2
	Drive motor or hydrostatic system failure	Refer to the hydrostatic drive section. Diagnose and make repairs as required.	2
Lubrication oil leaking through the filler / breather cap.	Lubricating oil level too high.	Check the oil level.	3.2
	Drive motor shaft seal leakage.	Inspect and repair damaged parts.	2
Wheel studs shearing off.	Wheel nuts loose.	Replace the wheel studs. Check wheel nut torque daily. Torque wheel nuts at 100 to 110 lbs/ft. (135 to 149 nm)	3.6
Wheel stud threads stripped.	Wheel nuts over tightened.	Replace the wheel studs. Check wheel nut torque daily. Torque wheel nuts at 100 to 110 lbs/ft. (135 to 149 nm)	3.6

