

SECTION 2 HYDRAULIC SYSTEM

Group 1	Hydraulic circuit	2-1
Group 2	Hydraulic component testing	2-3
Group 3	Self level valve(Optional)	2-14
Group 4	Auxiliary pump	2-20
Group 5	HST pump (Mechanical type)	2-36
Group 6	HST pump (Pilot type)	2-63
Group 7	Travel motor	2-82
Group 8	Main control valve	2-108
Group 9	Boom and bucket cylinder	2-122

SECTION 2 HYDRAULIC SYSTEM

GROUP 1 HYDRAULIC CIRCUIT

1. MECHANICAL TYPE

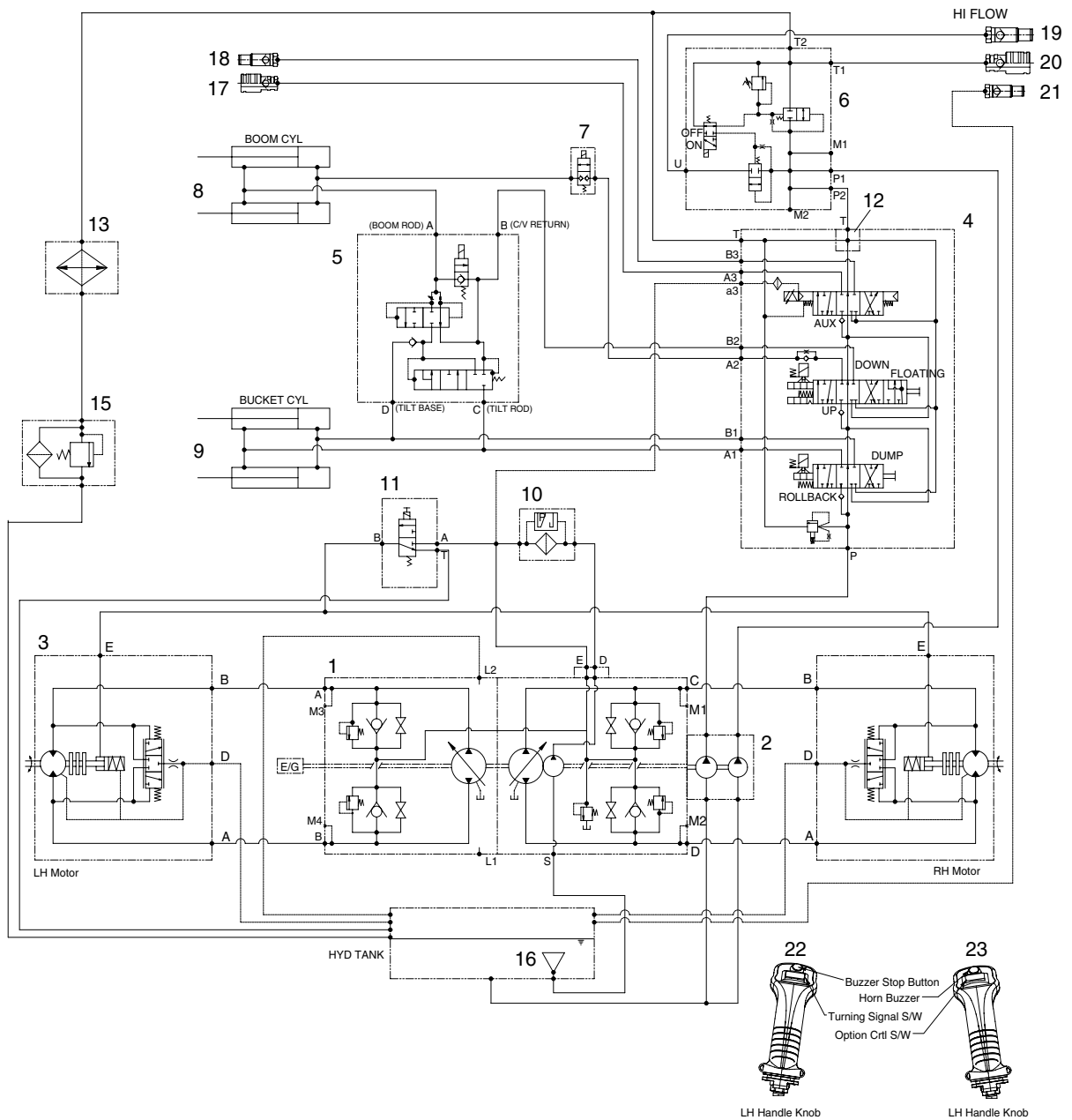

- | | | | | | |
|---|---------------------------|----|------------------------|----|--------------------------------|
| 1 | HST pump | 9 | Bucket cylinder | 18 | Quick coupler (male) |
| 2 | Auxiliary pump | 10 | Filter assy | 19 | Quick coupler (female, option) |
| 3 | Travel motor | 11 | Parking solenoid valve | 20 | Quick coupler (male, option) |
| 4 | Main control valve | 12 | Power beyond sleeve | 21 | Quick coupler (male, option) |
| 5 | Self level valve (option) | 13 | Oil cooler | 22 | Remote control valve-LH |
| 6 | High flow valve (option) | 15 | Return filter | 23 | Remote control valve-RH |
| 7 | Safety solenoid valve | 16 | Suction strainer | | |
| 8 | Boom cylinder | 17 | Quick coupler (female) | | |

2. PILOT TYPE

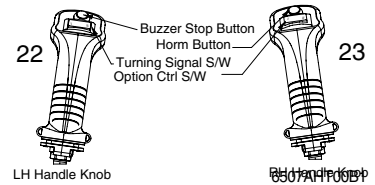
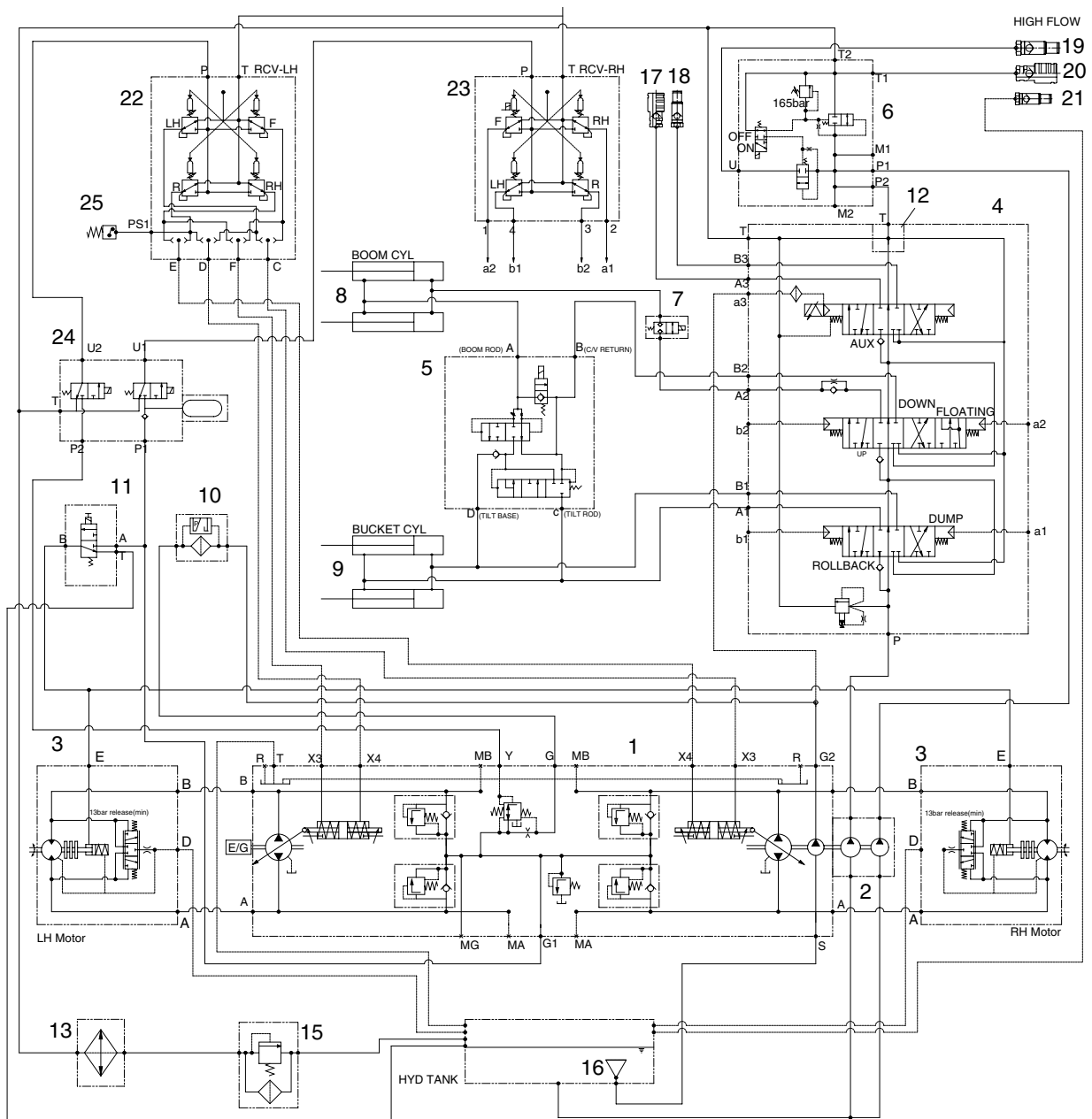

- | | | | | | |
|---|---------------------------|----|--------------------------------|----|------------------------------|
| 1 | HST pump | 10 | Filter assy | 20 | Quick coupler (male, option) |
| 2 | Auxiliary pump | 11 | Parking solenoid valve | 21 | Quick coupler (male, option) |
| 3 | Travel motor | 12 | Power beyond sleeve | 22 | Remote control valve-LH |
| 4 | Main control valve | 13 | Oil cooler | 23 | Remote control valve-RH |
| 5 | Self level valve (option) | 15 | Return filter | 24 | Pilot lock valve |
| 6 | High flow valve (option) | 16 | Suction strainer | 25 | Pressure switch |
| 7 | Safety solenoid valve | 17 | Quick coupler (female) | | |
| 8 | Boom cylinder | 18 | Quick coupler (male) | | |
| 9 | Bucket cylinder | 19 | Quick coupler (female, option) | | |