

GROUP 6 TRAVEL MOTOR

1. REMOVAL AND INSTALL

1) REMOVAL

▲ If engine is running or full up pressure into hydraulic system, absolutely does not repair or tighten hose, fitting. As hydraulic line explode, dangerous accident may occur.

- (1) Lowered the bucket on the ground.
- (2) Shut off engine and raise the seat bar.
- (3) Raising canopy and remove the front cover.
- ※ For raising and lowering of the canopy, refer to page 4-15 of the operator's manual.
- (4) Loosen the bolt(1) and remove the cover(2).
- (5) Separate input, output, drain line from travel motor and block the hole to avoid alien.
- (6) Remove the retaining ring(3).
- (7) Loosen bolt(4) from travel motor.
- (8) Remove travel motor, and put it on the work bench to make disassembly possible.

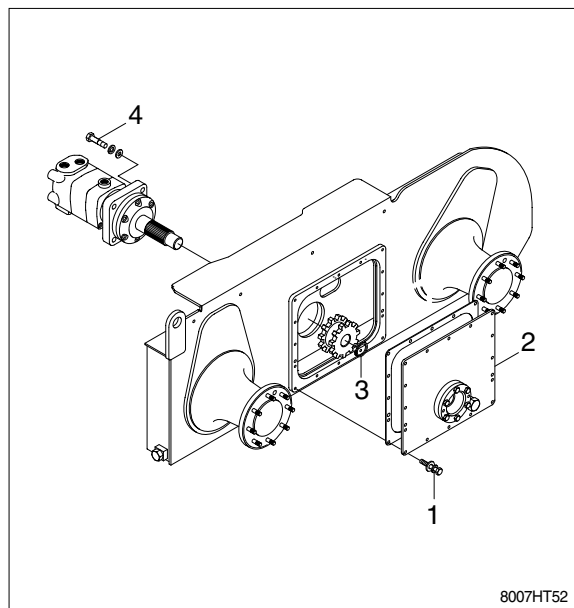

2) INSTALL

- (1) Paint silicon sealant to travel motor flange to prevent the final drive housing from oil leakage.

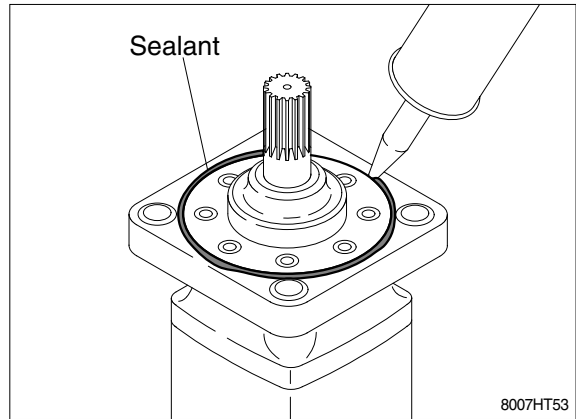

- (2) Tighten mounting bolt(4).
 - Torque : $12.8 \pm 3.0 \text{kgf} \cdot \text{m}$ ($92.6 \pm 21.7 \text{lb} \cdot \text{ft}$)
- (3) Release the plug out of the motor port and remove the cap from the hydraulic hose.
- (4) Assemble hose assembly linked to the lower port connector of the travel motor.
- (5) Assemble hose assembly linked to the upper port connector of the travel motor.
- (6) Assemble hose assembly(Drain) linked to travel motor connector from the oil tank elbow.
- (7) Assemble the retaining ring(3).
- (8) Assemble the cover(2) and tighten the bolt(1).
 - Torque : $6.9 \pm 1.4 \text{kgf} \cdot \text{m}$ ($49.9 \pm 10.1 \text{lb} \cdot \text{ft}$)

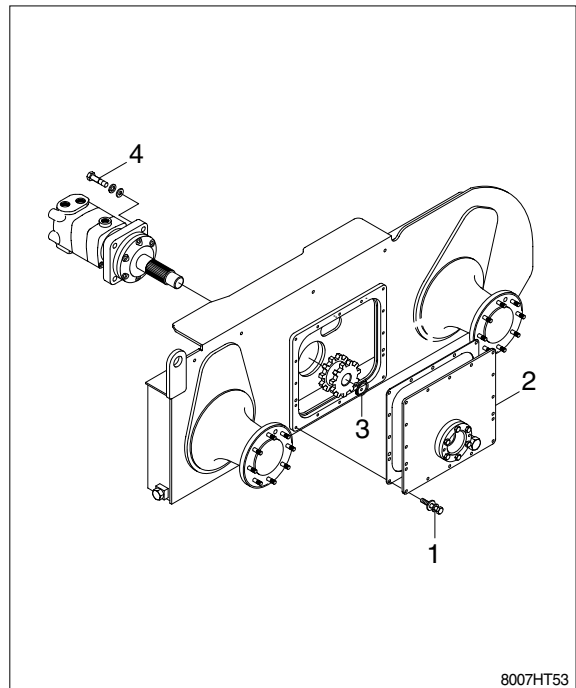

2. STRUCTURE

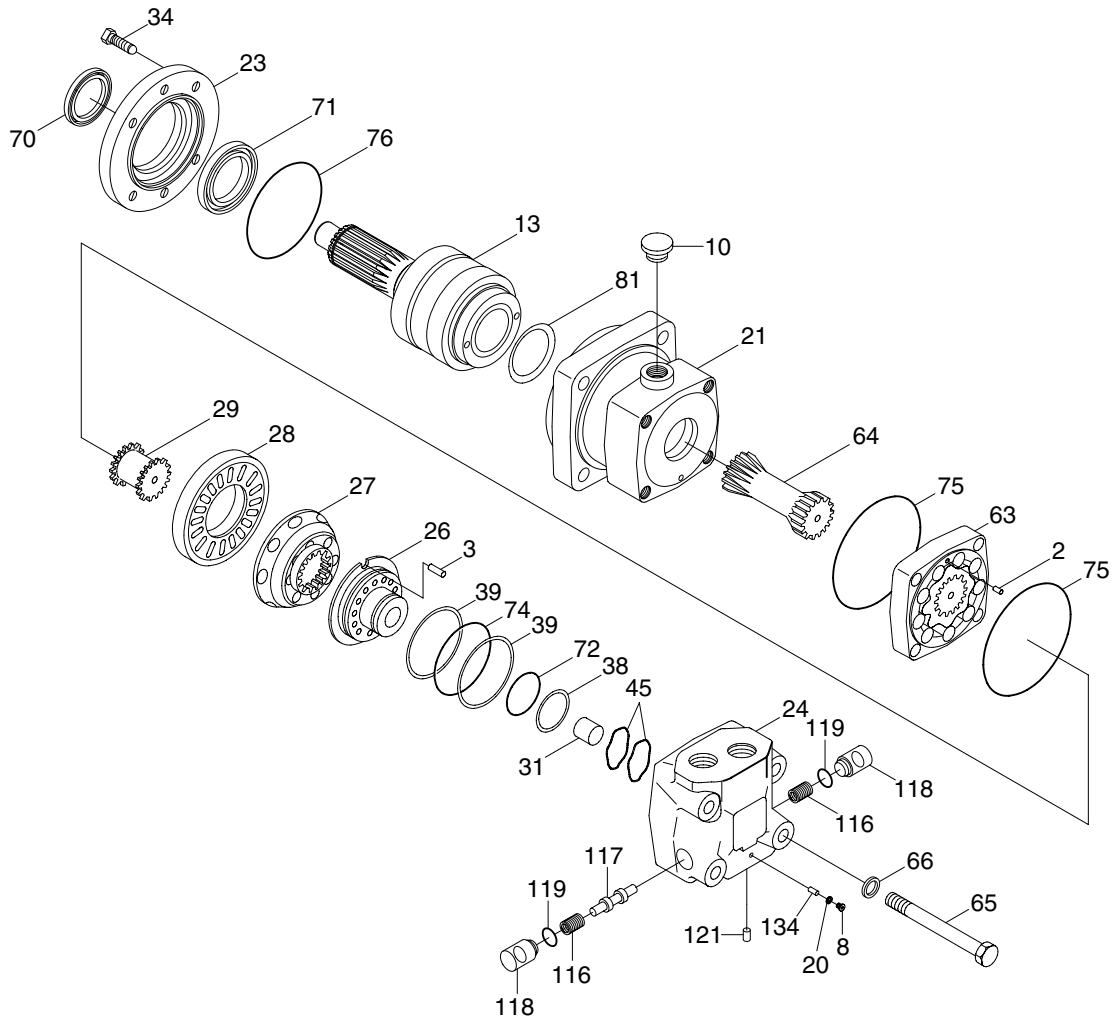

8007HT33

2	Guide pin(\varnothing 4, 10mm)	29	Valve drive	71	Shaft seal
3	Guide pin(\varnothing 5, 14mm)	31	Spacer	72	O-ring
8	Plug	34	Screw	74	O-ring
10	Drain plug(\varnothing 1.5" with bearing)	38	Back up ring	75	O-ring
13	Spline shaft	39	Back up ring	76	O-ring
20	Washer	45	Spring washer	81	Seal ring
21	Bearing housing	63	Gear wheel set	116	Compression spring
23	Front cover	64	Cardan shaft	117	Spool
24	Valve housing	65	Hexagon screw	118	Plug
26	Balance plate	66	Washer	119	O-ring
27	Disc valve	70	Dust seal ring	121	Plug
28	Channel plate	71	Shaft seal	134	Throttle screw

3. TOOLS

1) MAIN HOLDING TOOL

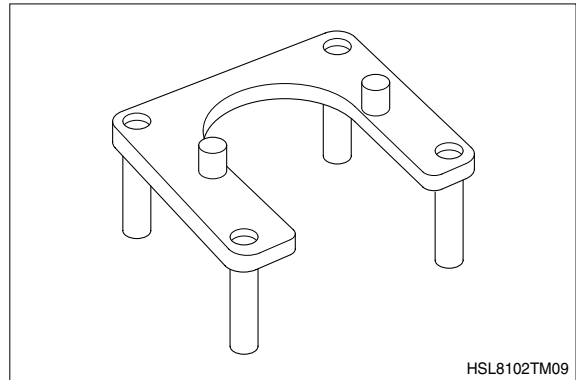

2) HOLDING TOOL

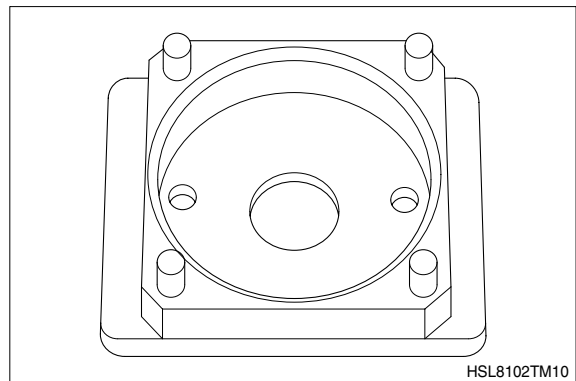

3) MANDREL FOR OUTPUT SHAFT REMOVAL

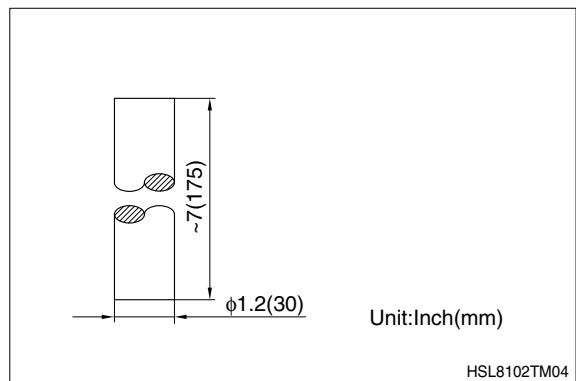

4) MANDREL AND BACKSTOP FOR FITTING SHAFT SEAL

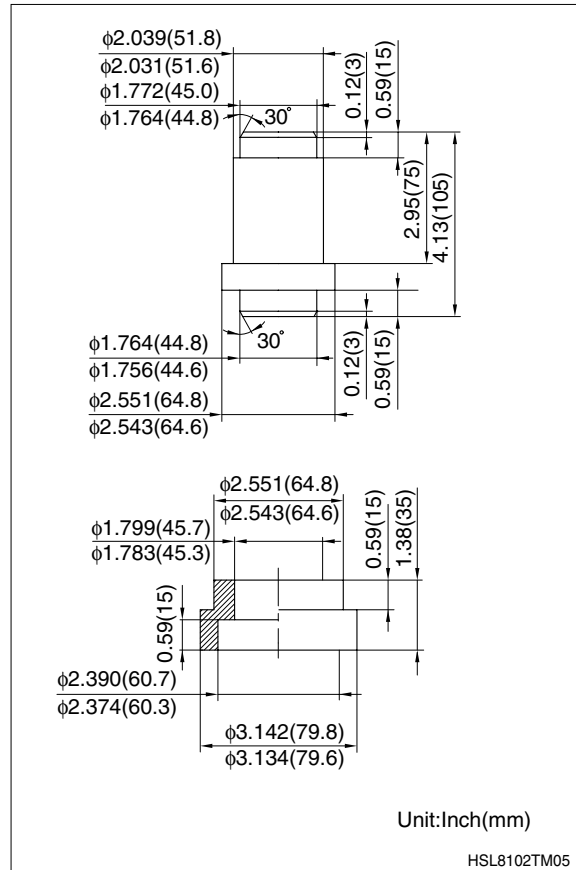

5) TWO GUIDE BOLTS

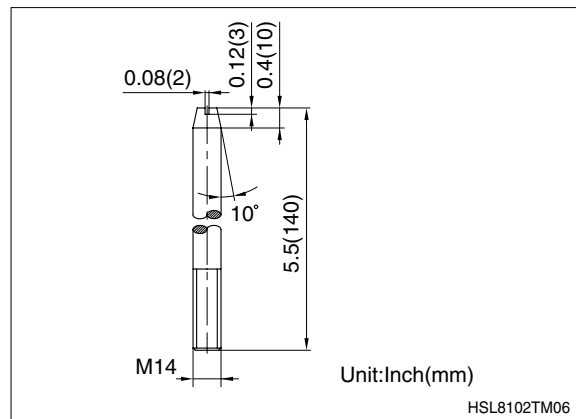

6) MANDREL TO REMOVE BALANCE PLATE

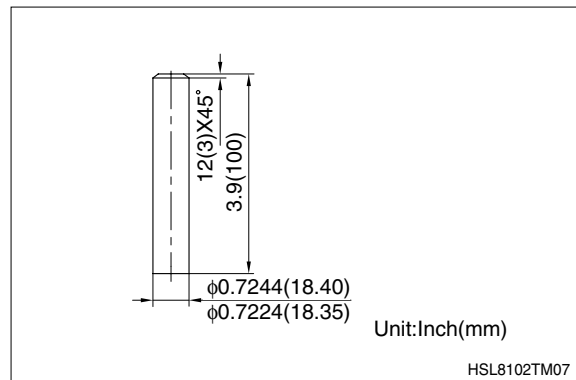

4. DISASSEMBLY

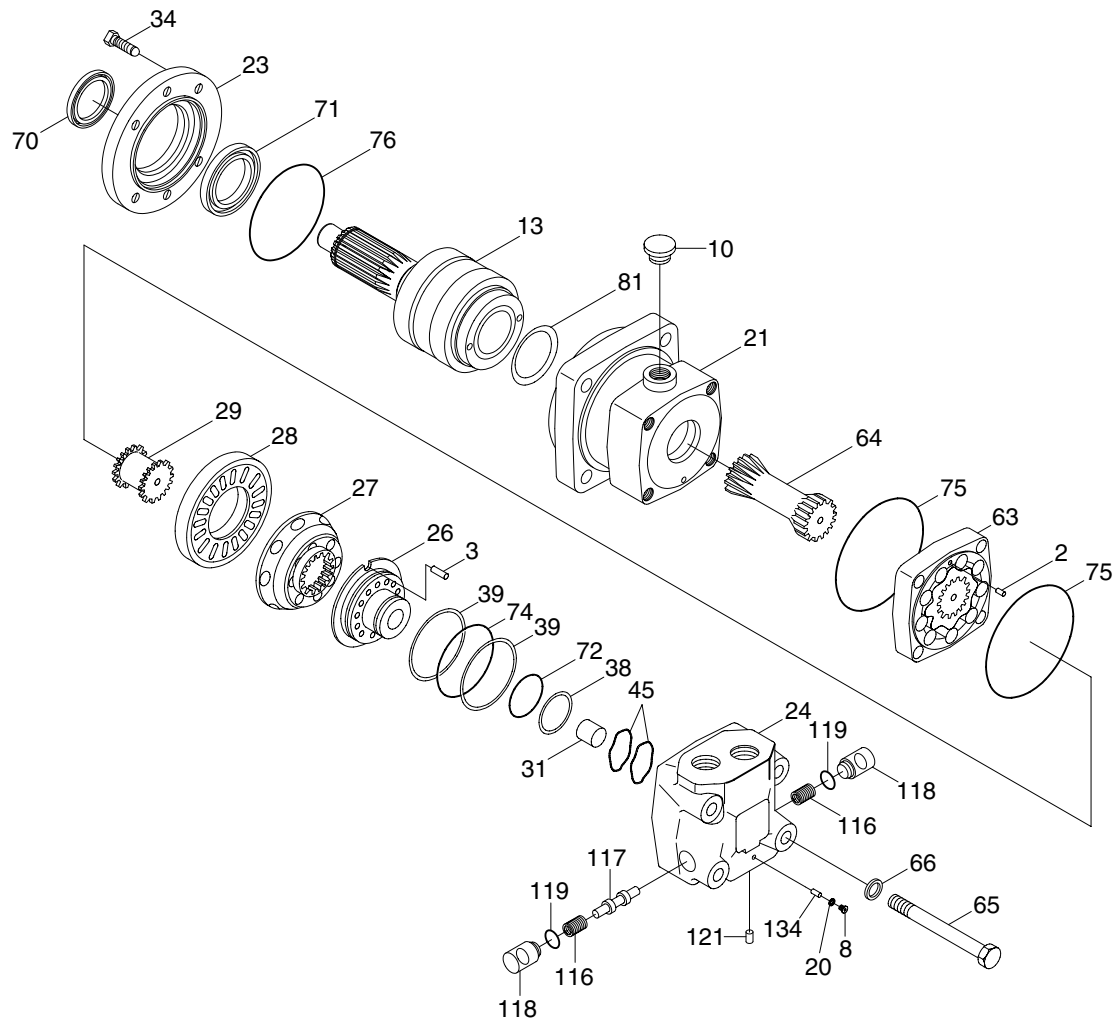

8007HT33

※ Cleanliness is extremely important when repairing a hydraulic motor.

Work in a clean area. Before disconnecting the lines, clean port area of motor thoroughly. Use a wire brush to remove foreign material and debris from exterior joins of motor. Check shaft and keyway, use 600 grit paper/cloth to remove all nicks. Burrs and sharp edges that might damage the shaft seals when installing retainer on shaft and bearing assembly. Before starting disassembly procedures, drain oil from inside of motor.

1) Place motor in a vise with output shaft down. Clamp across edge of bearing housing not on housing. Excessive clamping pressure on housing will cause distortion. When clamping, use some protective device on vise, such as special soft jaws, pieces of hard rubber or board.

Although not all drawings show the motor in a vise, we recommend that you keep the motor in the vise during disassembly.

Follow the clamping procedures explained throughout the manual.

2) Place the motor in holding tool and remove plug(8) and washer(20).

※ Use 5mm allen head spanner.

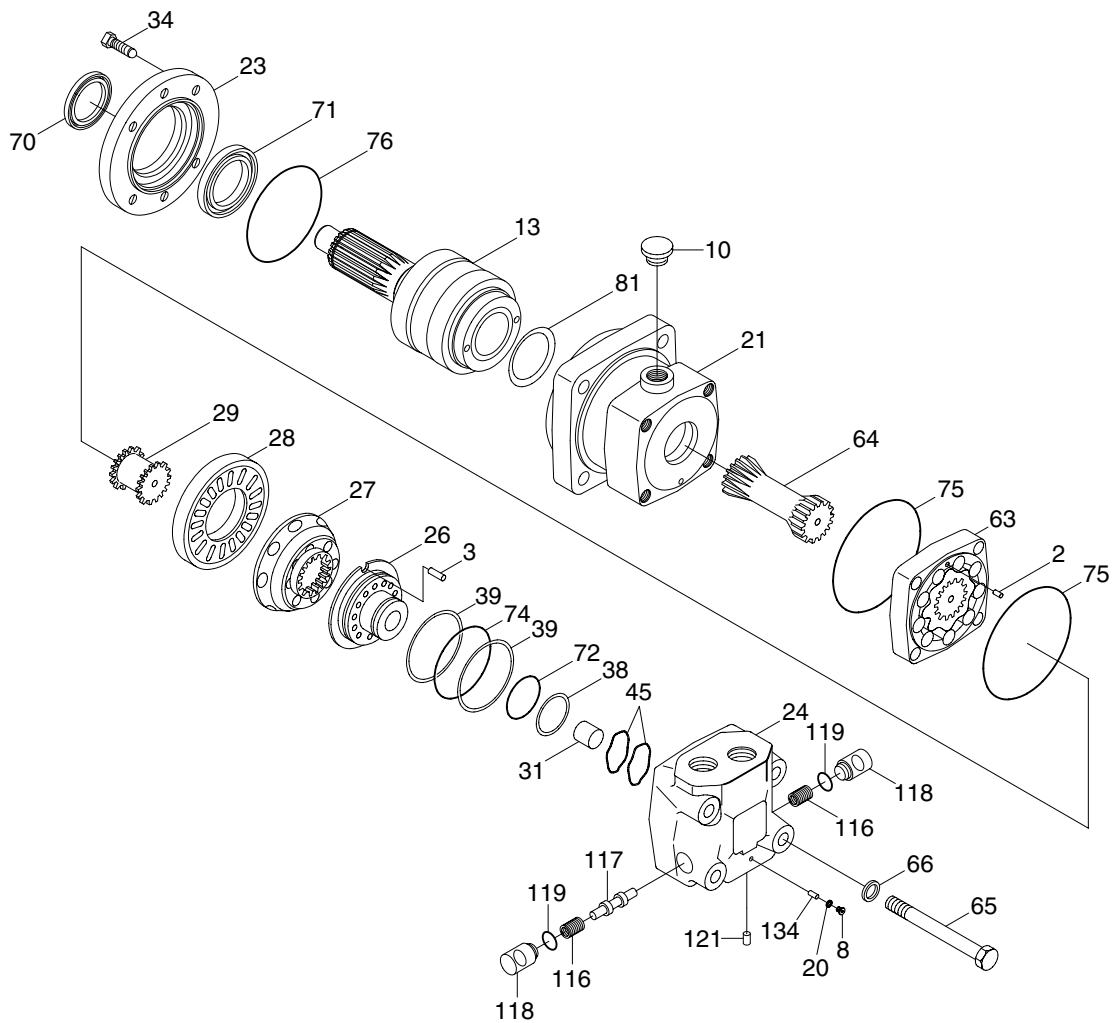

8007HT33

- 3) Tilt motor, screw(134) come out.
- 4) Remove 4 bolts(65) from motor.
※ Use 22mm socket spanner.
- 5) Lift off carefully as a unit, holding your fingers under the channel plate(28).
- 6) Remove O-ring(75) from channel plate(28).
- 7) Remove channel plate(28).
- 8) Remove disc valve(27).
- 9) Remove spacer(31).
- 10) Fill in oil into the spacer hole and use the \varnothing 18.4mm mandrel as a piston to press up the balance plate and remove balance plate(26).
- 11) Remove guide pin(3) and rings(38, 39, 72, 74), 2 spring washers(45) from valve housing.
- 12) Remove valve drive(29).

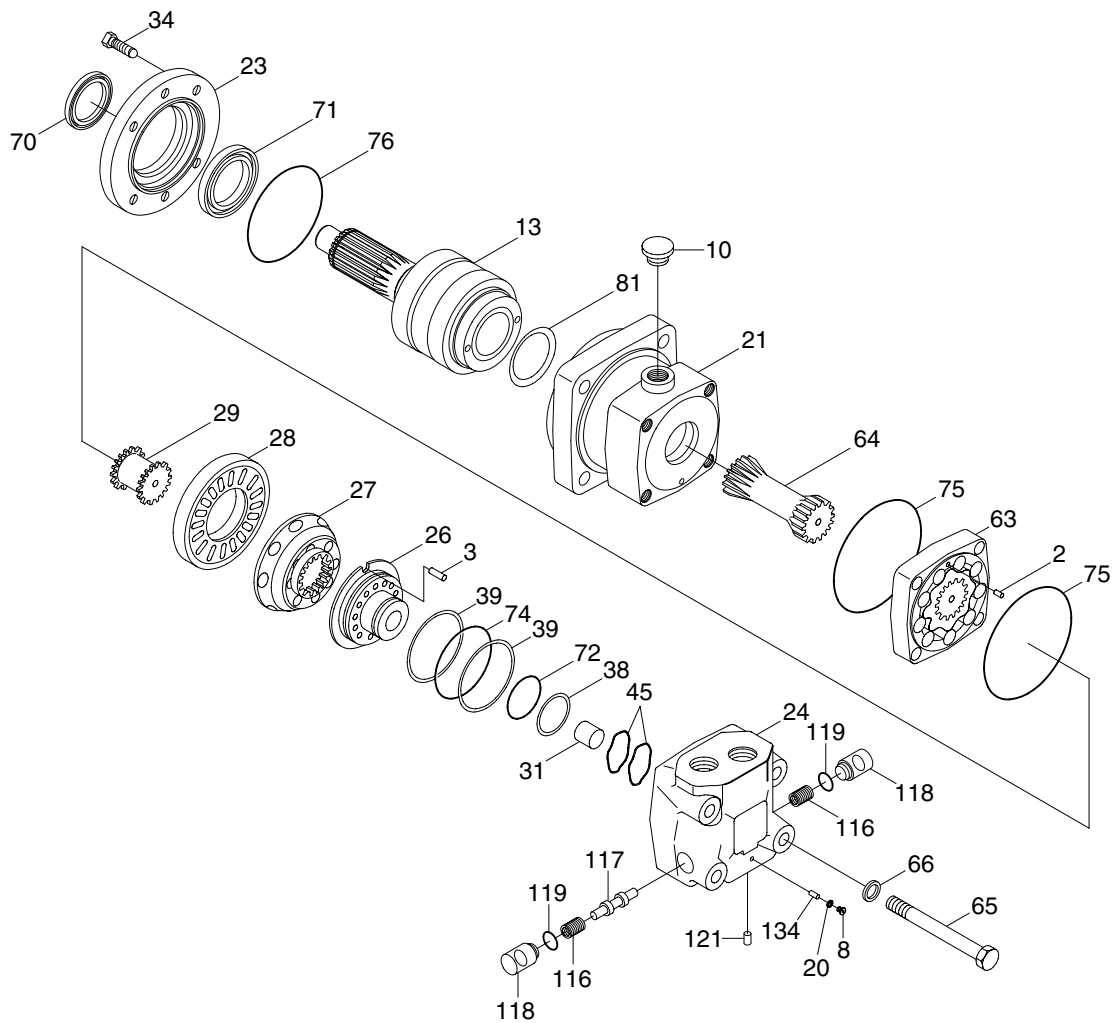

8007HT33

- 13) Remove guide pin(2).
 - 14) Hold fingers under the gearwheel set(63) to prevent the parts from dropping out.
 - 15) Remove O-ring(75) from gearwheel set(63).
 - 16) Remove cardan shaft(64).
 - 17) Remove seal ring(81).
 - 18) Unscrew with 13mm socket spanner.
 - 19) Remove front cover(23) and O-ring(76).
 - 20) Dust seal(70) and shaft seal(76) to be knocked out by means of the special mandrel(4 on page 2-53).
 - 21) Press out the shaft/bearing assembly using a hydraulic press(Pressing force max 550lbf) using the special mandrel(3 on page 2-52).
- ※ Shaft/bearing assembly should not be disassembly.

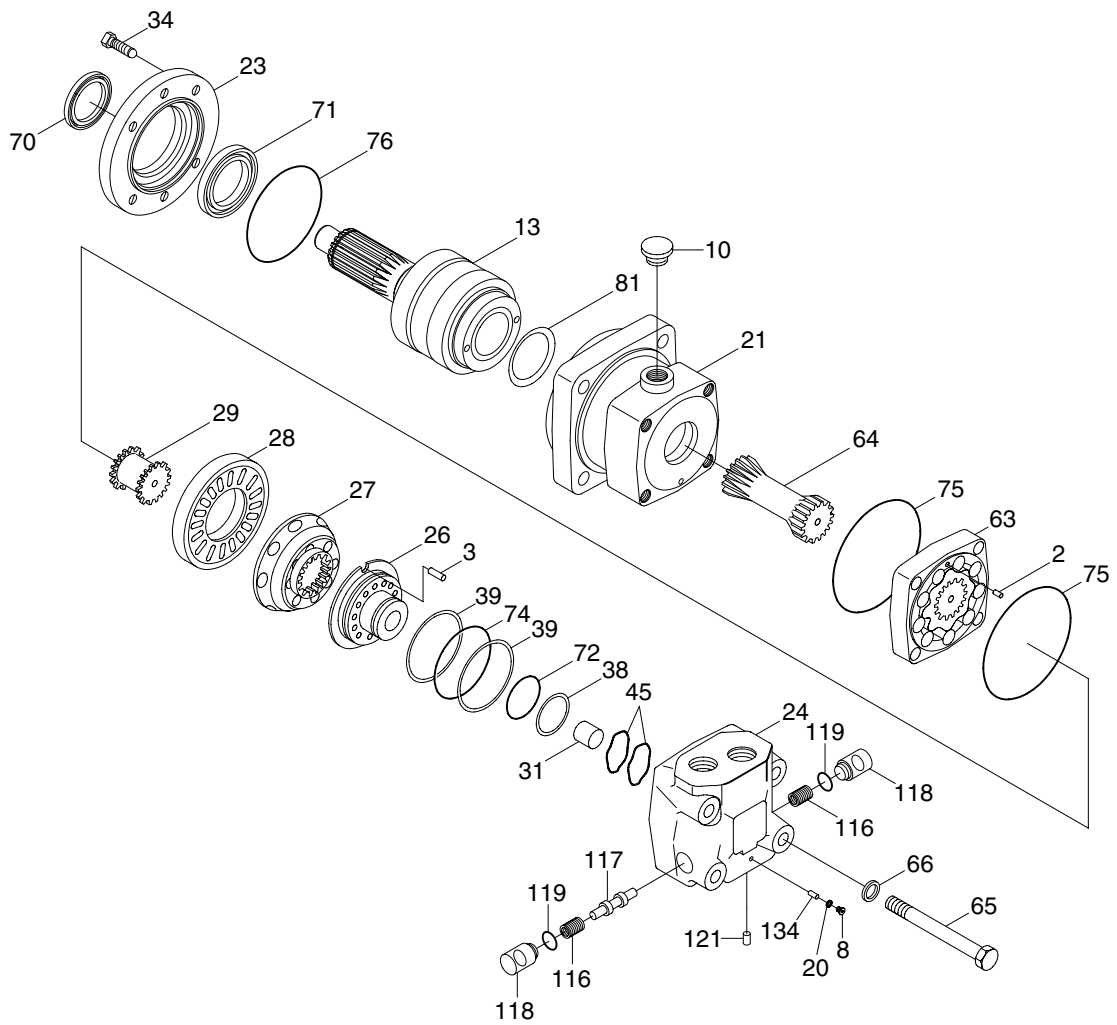

8007HT33

22) Remove plugs(118) and spring(116), spool(117) from valve housing(29).

23) Remove O-ring(119) from plugs(118).

- ※ After disassembling, clean all parts in low aromatic kerosene.
- ※ Examine the parts and exchange them if necessary.
- ※ Immediately before assembly, lubricate each part with hydraulic oil and grease rubber parts with vaseline.

5. REASSEMBLY

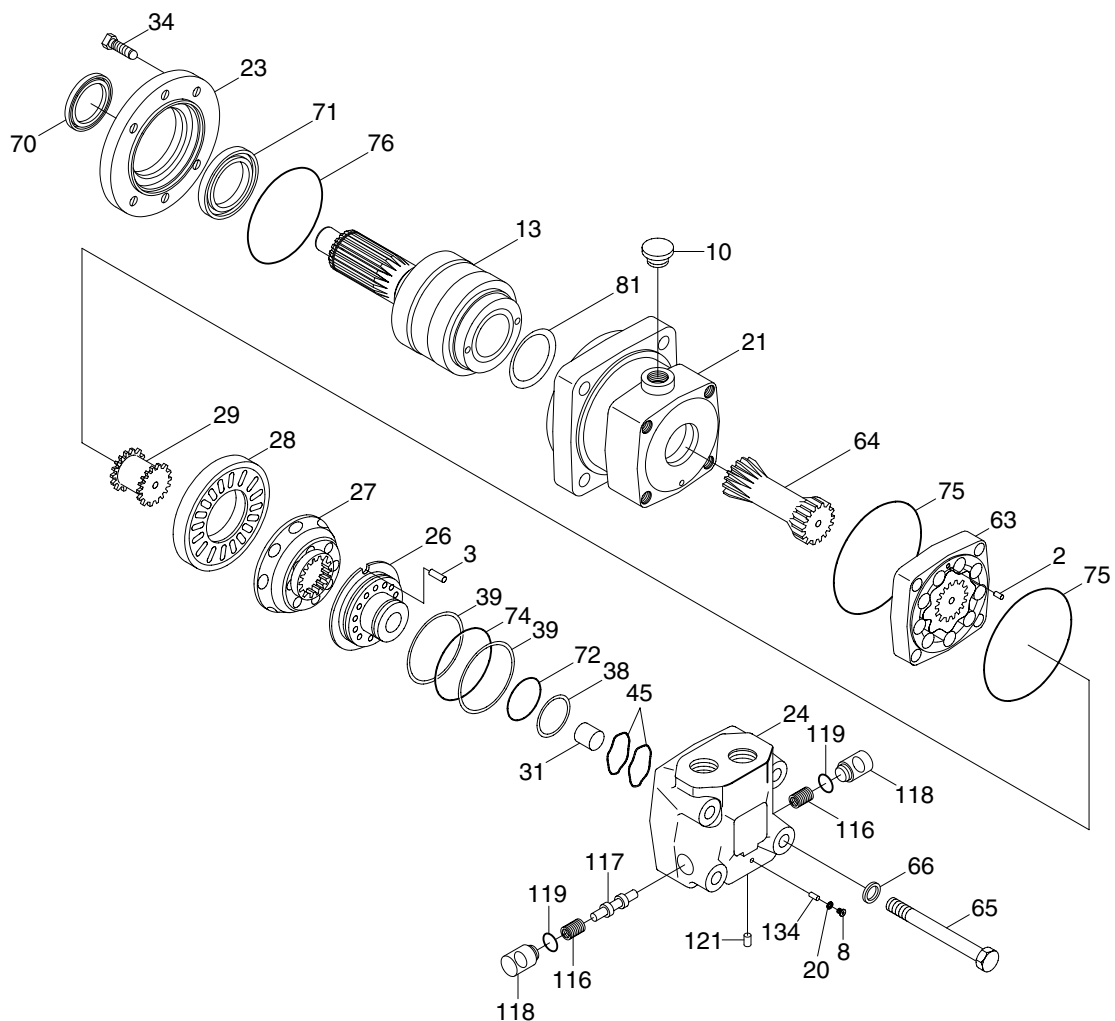

8007HT33

※ Check all mating surfaces. Replace any parts that have scratches or burrs that could cause leakage. Clean all metal parts in clean solvent. Blow dry with air. Do not wipe with cloth or paper towel because lint or other matter could get into the hydraulic system and cause damage. Do not use coarse grit papers/cloth or try to file or grind motor parts. Check around the keyway and chamfered area of the shaft for burrs, nicks or sharp edges that can damage the seals when reassembling the retainer.

※ Lubricate all seals (Prior to installation) with petroleum jelly such as vaseline. Use new seals when reassembling the motor.

- 1) Fit seal ring(81) into recess in bearing housing, placed in the holding tool.
- 2) Fit shaft / bearing assy(13) into housing(21). Use the hydraulic press(Max 250kgf(550lbf)).
- 3) Knock shaft seal(71) into position in the front cover, using the assembly mandrel. Grease lip with vaseline.
- 4) Assemble dust seal(70) to front cover(23).
Use assembly mandrel, plastic hammer and support(To prevent the shaft seal from being knocked out). Grease lip with vaseline.

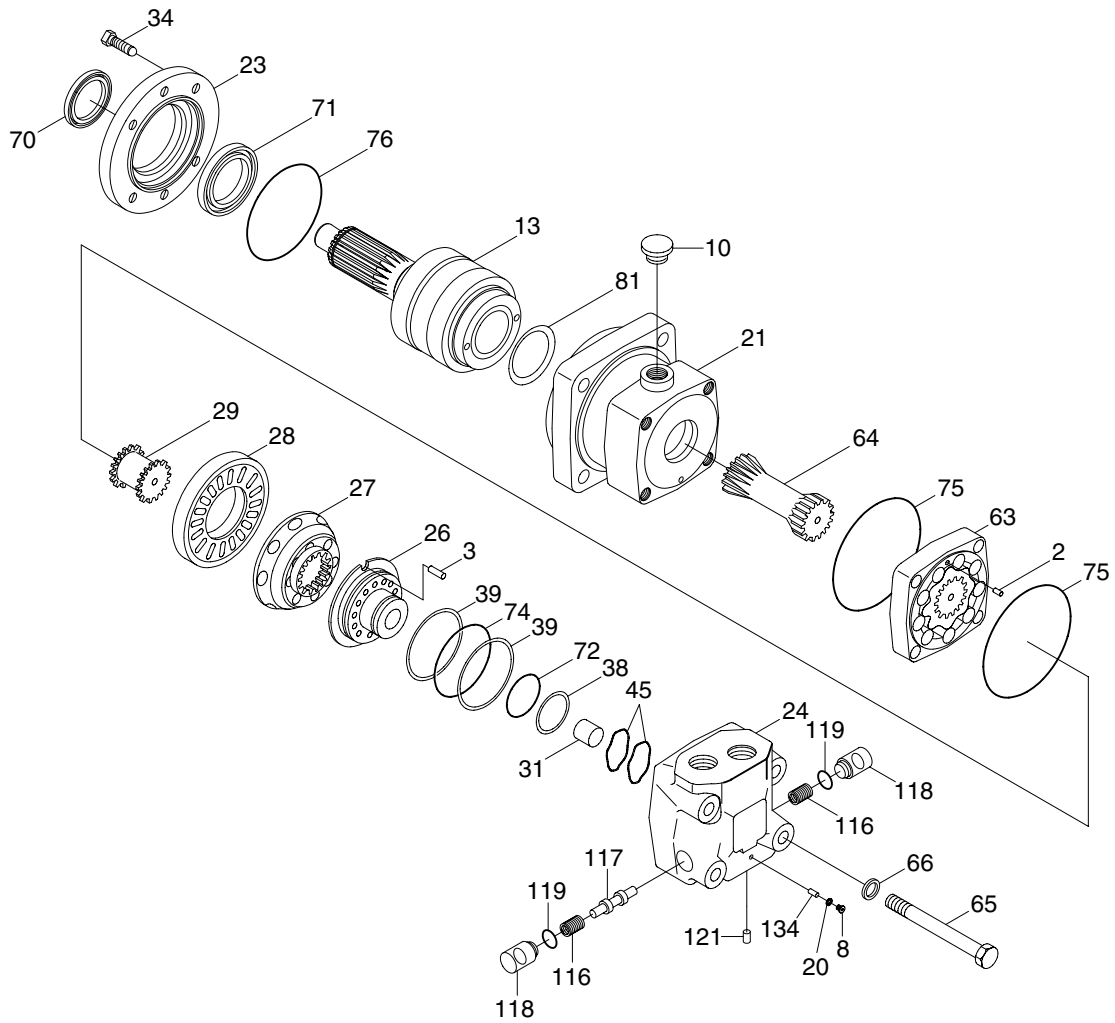

8007HT33

- 5) Assemble O-ring(76) to front cover(23). Grease with vaseline.
- 6) Tighten cover(23) and bearing(21) with screw(34). Use 13mm socket spanner. Turn the motor upside down. Fill up splines area in the shaft with oil. Mount 2 off guide bolts.
 - Tightening torque : 27~31.8kgf · m
(195~230lbf · in)
- 7) Assemble cardan shaft(64) to bearing housing(21). If visible difference in splines length. Longest splines to be mounted in the output shaft.
- 8) Fit O-ring(75) to gear wheel set(63). Grease with vaseline.

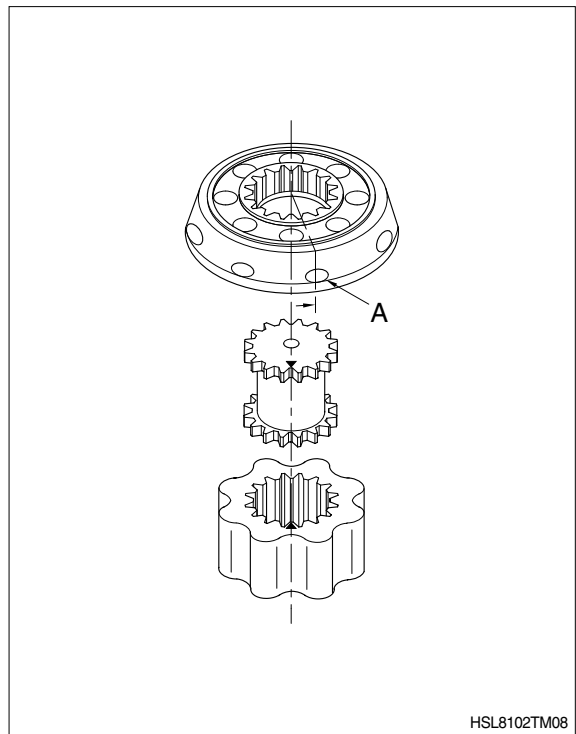

HSL8102TM08

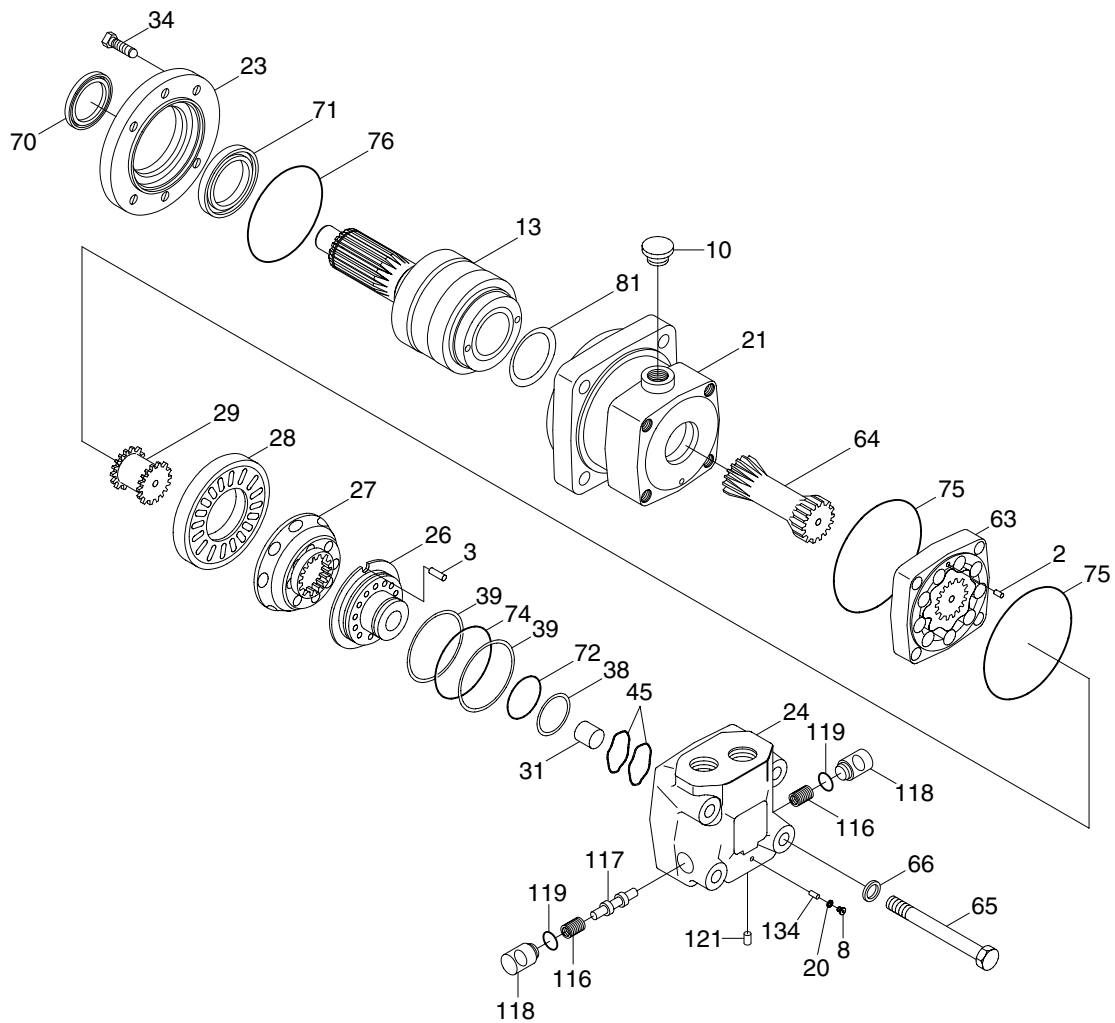

8007HT33

- 9) Hold fingers under the gearwheel set(63) to prevent parts from dropping out. Hole(6mm) to be aligned with hole in the bearing housing(21). Mark the gearwheel set(63) rotor at the point where the tip of a spline tooth is opposite the bottom of a tooth in the external rotor teeth(Right fig).
- 10) Mark the bottom of a spline tooth on the valve drive(29). Line up mark on rotor and valve drive (29).
- 11) Grease with vaseline to O-ring(75) and mount in channel plate(28) groove.
- 12) Assemble gearwheel set(63) and channel plate(28) with guide pin(2).
Align mark on valve drive(29) with a hole in the outer rim(A on drawing previous page). Turn disc valve(27) counter clockwise until splines in the two parts engage.
- 13) Place 2 spring washer(45) into valve housing(24).
- 14) Fit the two O-rings(Greased with vaseline, 72, 74) and 2 back up ring(30) in the balance plate(26) grooves.
- 15) Mount guide pin(3) in valve housing(24).

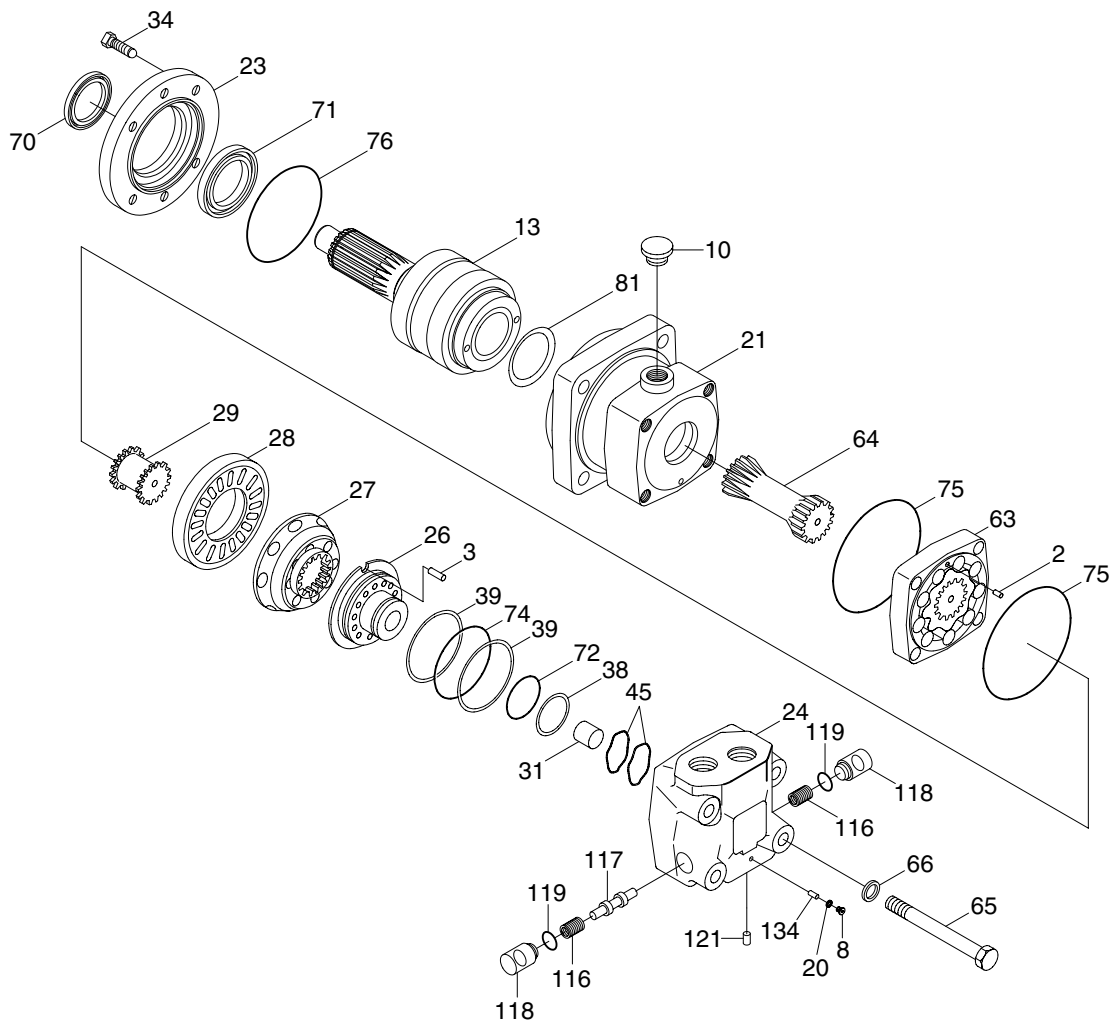

8007HT33

- 16) Grease with vaseline to prevent the spacer(31) from dropping out in balance plate(26).
- 17) Mount valve housing(24) on the rest of the motor. Ports should face in the same direction as the drain port.
- 18) Lubricate threads and cross tighten 4 hexagonal bolts(65).
 - Tightening torque : 164.5~177kgf · m(1190~1280lbf · in)
- 19) Screw in the orifice(134) and tighten it.
- 20) Plug the hole with plug(8) and washer(20) and tighten it.
- 21) Lubricate the two O-ring(119) with hydraulic oil or grease and place them in the bottom of the holes.
- 22) Place the spool(117) with the two spring(116).
- 23) The two plug(118) must be greased on the tapered end and the surface for the O-ring before they are preset in the holes.