

GROUP 7 MAIN CONTROL VALVE

1. REMOVAL AND INSTALL

1) REMOVAL

▲ If engine is running or full up pressure into hydraulic system, absolutely does not repair or tighten hose, fitting. As hydraulic line explode, dangerous accident may occur.

- (1) Lowered the bucket on the ground.
- (2) Shut off engine and raise the seat bar.
- (3) Rasing canopy and remove the front cover.
For raising and lowering of the canopy, refer to page 4-15 of the operator's manual.
- (4) Separate the linkage connecting valve spool with control lever.
- (5) Separate the hydraulic inlet and outlet line of main control valve.
- (6) Loosen the mounting bolt(1).
- (7) Take off the valve and put it on the work bench.

2) INSTALL

- (1) Install the valve and tighten the mounting bolt(1).
 - Tightening torque : $2.5 \pm 0.5 \text{kgf} \cdot \text{m}$ ($18.1 \pm 3.6 \text{lb} \cdot \text{ft}$)
- (2) Assemble the inlet and outlet hoses.
- (3) Connect the cable between valve spool and control lever.

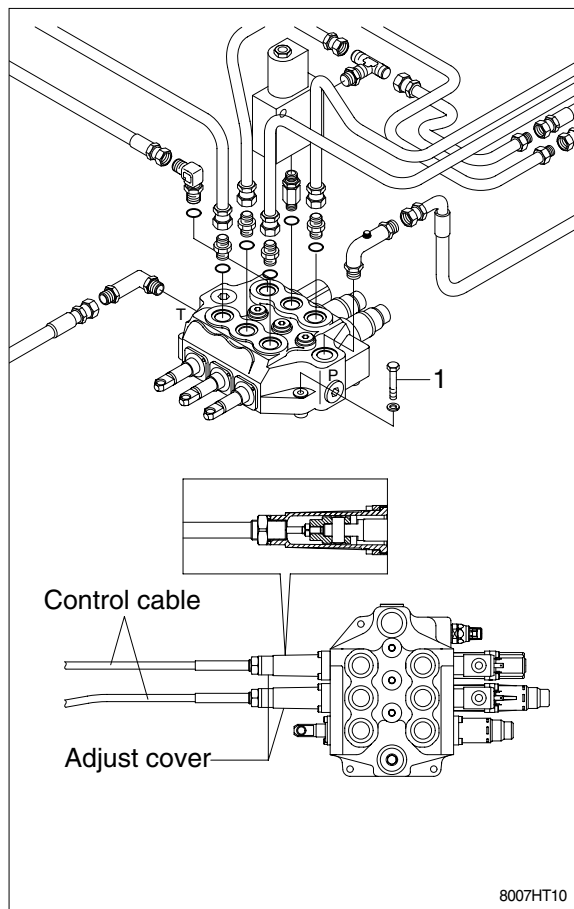

2. STRUCTURE(Main control valve and control kit)

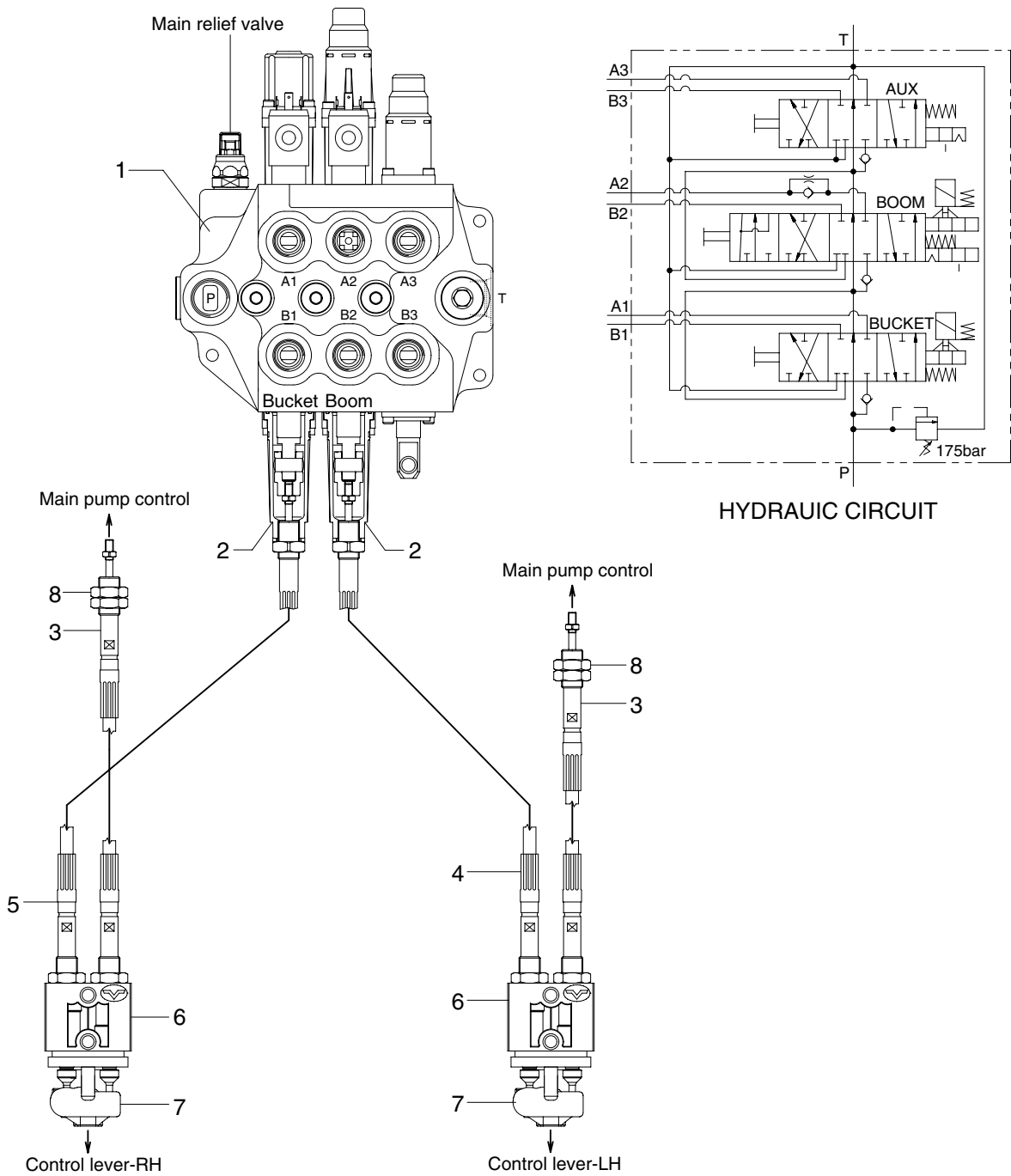

- 1 Main control valve
- 2 Adjust cover
- 3 Cable

- 4 Cable
- 5 Cable
- 6 Body kit

- 7 Cinematic kit
- 8 Nut

8007HT11

STRUCTURE(Main control valve)

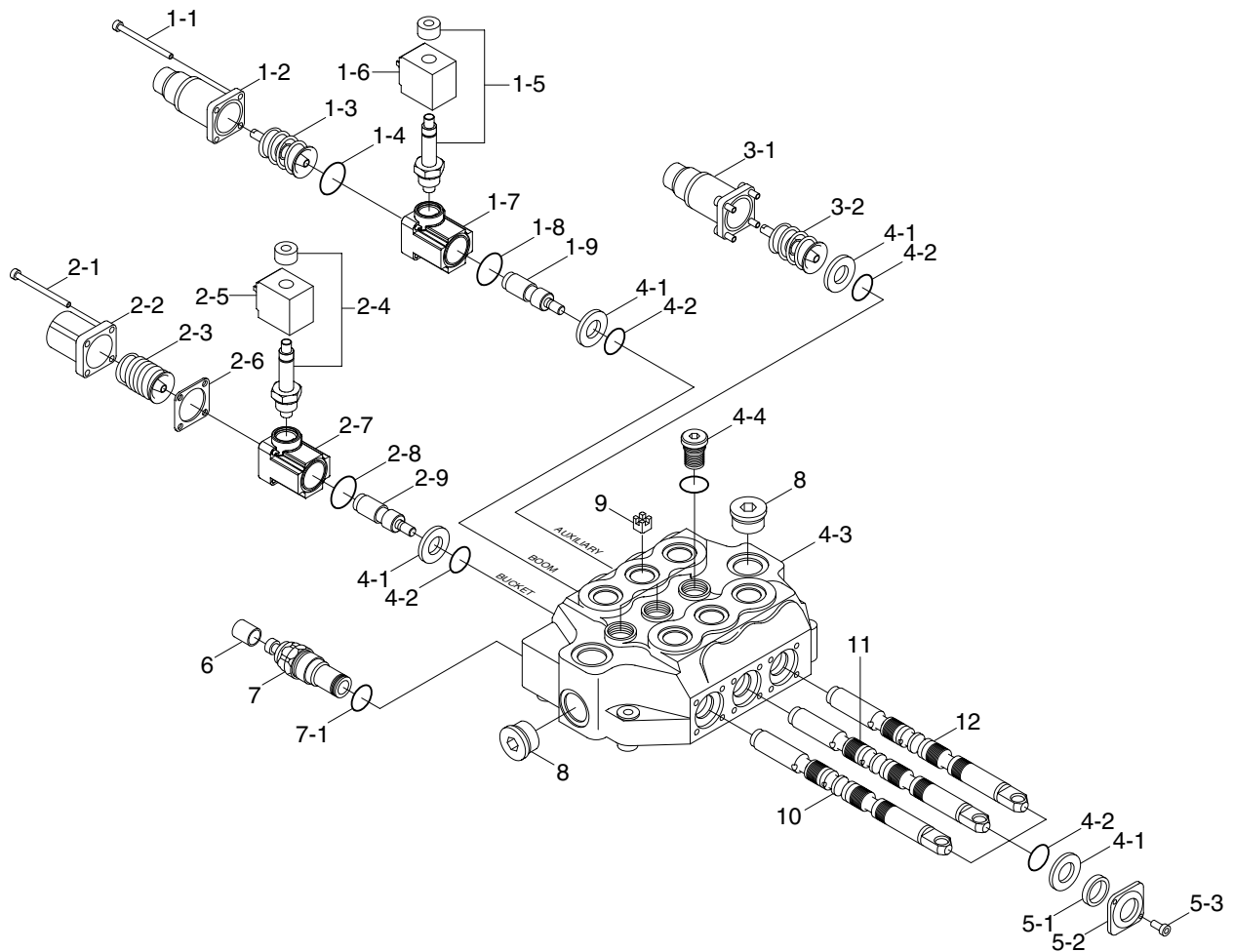

8007HT34

1-1	Screw	2-4	Spool assembly	5-1	Dust wiper
1-2	End cap kit	2-5	Coil	5-2	Flange
1-3	Detent kit	2-6	Seal	5-3	Screw
1-4	O-ring	2-7	Spacer	6	Plastic cover
1-5	Spool assembly	2-8	O-ring seal	7	Main relief valve
1-6	Coil	2-9	Joint	7-1	O-ring
1-7	Spacer	3-1	End cap	8	Plug
1-8	O-ring seal	3-2	Detent kit	9	Orifice
1-9	Joint	4-1	Ring	10	Bucket spool
2-1	Screw	4-2	O-ring	11	Boom spool
2-2	End cap	4-3	Body	12	Auxiliary spool
2-3	Spring kit	4-4	Load check valve		

3. DISASSEMBLY AND ASSEMBLY

1) BOOM SPOOL

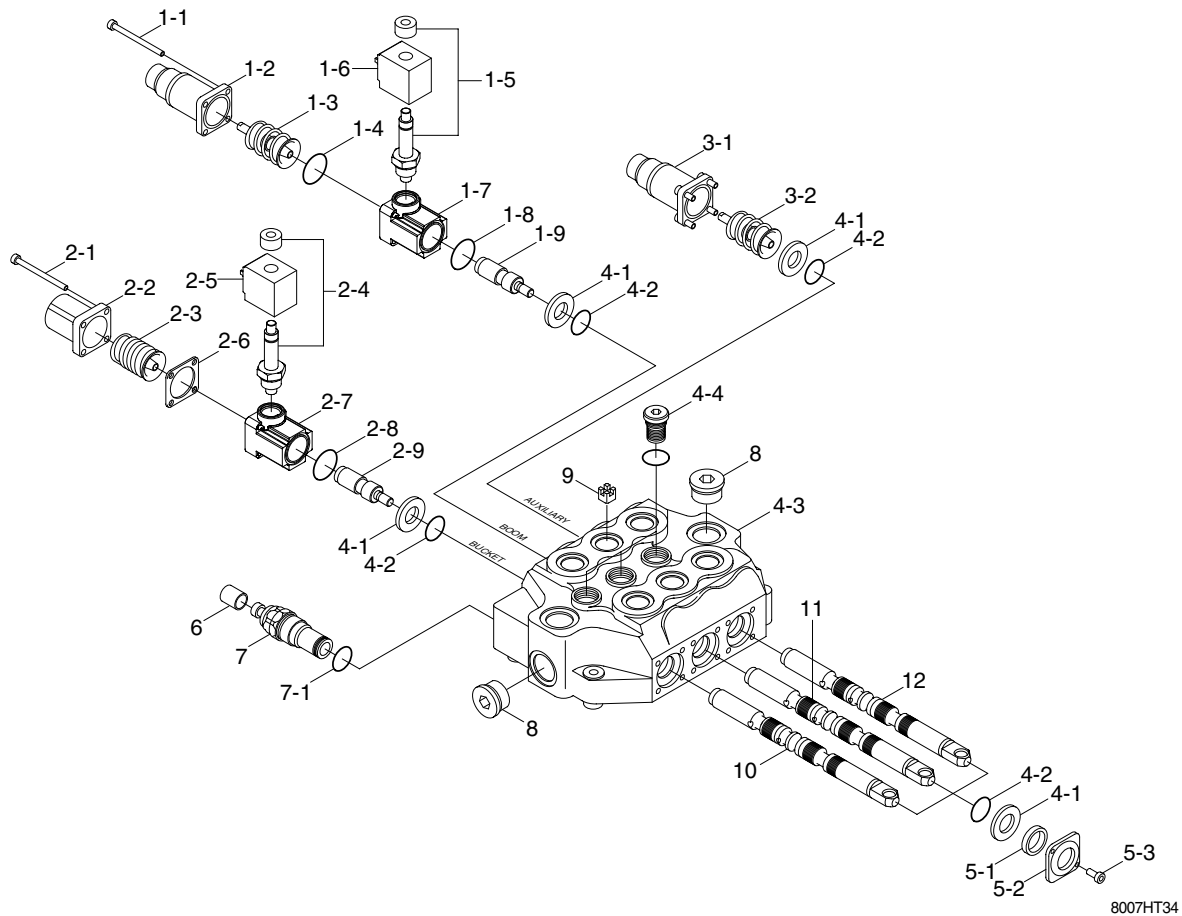

(1) Disassembly

- ① Remove the end cap(1-2) by removing the four mounting screws(1-1).
- ② Remove the detent kit(1-3), spacer(1-7), O-ring seal(1-8), joint(1-9), ring(4-1) and O-ring(4-2).
- ③ Carefully remove the boom spool(11) from the valve body(4-3) and inspect. If spool shows any signs of wear or scoring the entire valve must be replaced.
- ④ Remove the ring(4-2) and the O-ring(4-1) from the valve body(4-3) using care not to scratch the bore and not to contaminate the bore with foreign.
- ⑤ Clean and dry all parts with a suitable solvent. Use petroleum based fuel or mineral spirits.

(2) Assembly

- ① Lubricate the new O-ring(4-2) and ring(4-1) with clean oil. Pinch the lubricate O-ring and insert the O-ring and the ring into the groove in the front and in the back of the valve. Use care not to cut or nick the O-ring during assembly.
- ② Insert the boom spool(11) to the body(4-3).
- ③ Insert the detent kit(1-3) to end cap(1-2). Assemble the joint, O-ring seal, spacer.
Assemble the detent kit(1-3) and tighten torque to $2.5\text{kgf} \cdot \text{m}(7.38\text{lbf} \cdot \text{ft})$.
- ④ After assembly check for operation of the spring by pushing down on the detent. This should compress the spring and should return when released. Apply grease(Castro spherol TN) to the spring and bushes.
- ⑤ Place the end cap(1-2) over the assembly and install the mounting screws(1-1) and tighten torque to $0.7\text{kgf} \cdot \text{m}(53.5\text{lbf} \cdot \text{ft})$.

2) BUCKET SPOOL

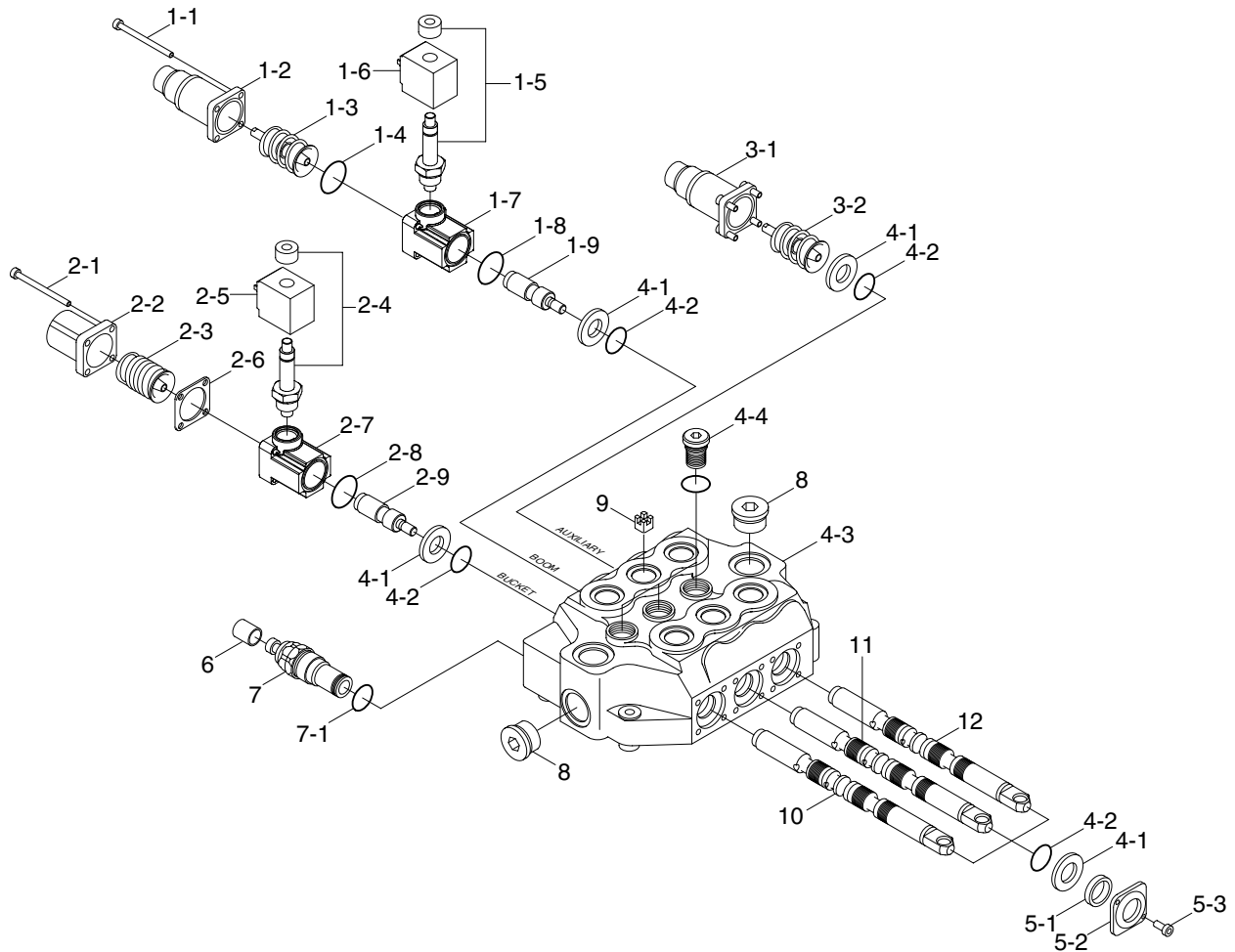

8007HT34

(1) Disassembly

- ① Remove the end cap(2-2) by removing the four mounting screw(2-1).
- ② Remove the spring kit(2-3), spacer(2-7), O-ring seal(2-8), joint(2-9), ring(4-1) and O-ring(4-2).
- ③ Carefully remove the bucket spool(10) from the valve body(4-3) and inspect. If spool shows any signs of wear or scoring the entire valve must be replaced.
- ④ Remove the ring(4-1) and the O-ring(4-2) from the valve body(4-3) using care not to scratch the bore and not to contaminate the bore with foreign.
- ⑤ Clean and dry all parts with a suitable solvent. Use petroleum based fuel or mineral spirits.

(2) Assembly

- ① Lubricate the new O-ring(4-2) and ring(4-1) with clean oil. Pinch the lubricate O-ring and insert the O-ring(4-2) and the ring(4-1) into the groove in the front and in the back of the valve. Use care not to cut or nick the O-ring during assembly.
- ② Insert the bucket spool(10) to the body(4-3).
- ③ Insert the spring kit(2-3) to end cap(2-2). Assemble joint(2-9), O-ring seal(2-8), spacer(2-7) and seal(2-6). Assemble the spring kit(2-3) and tighten torque to 2.5kgf · m(7.38lbf · ft).
Apply grease(Castrol spheerol TN) to the spring and bushes.
- ④ Place the end cap(2-2) over the assembly and install the mounting screws(2-1) and tighten torque to 0.7kgf · m(54.2lbf · ft).

3) AUXILIARY SPOOL

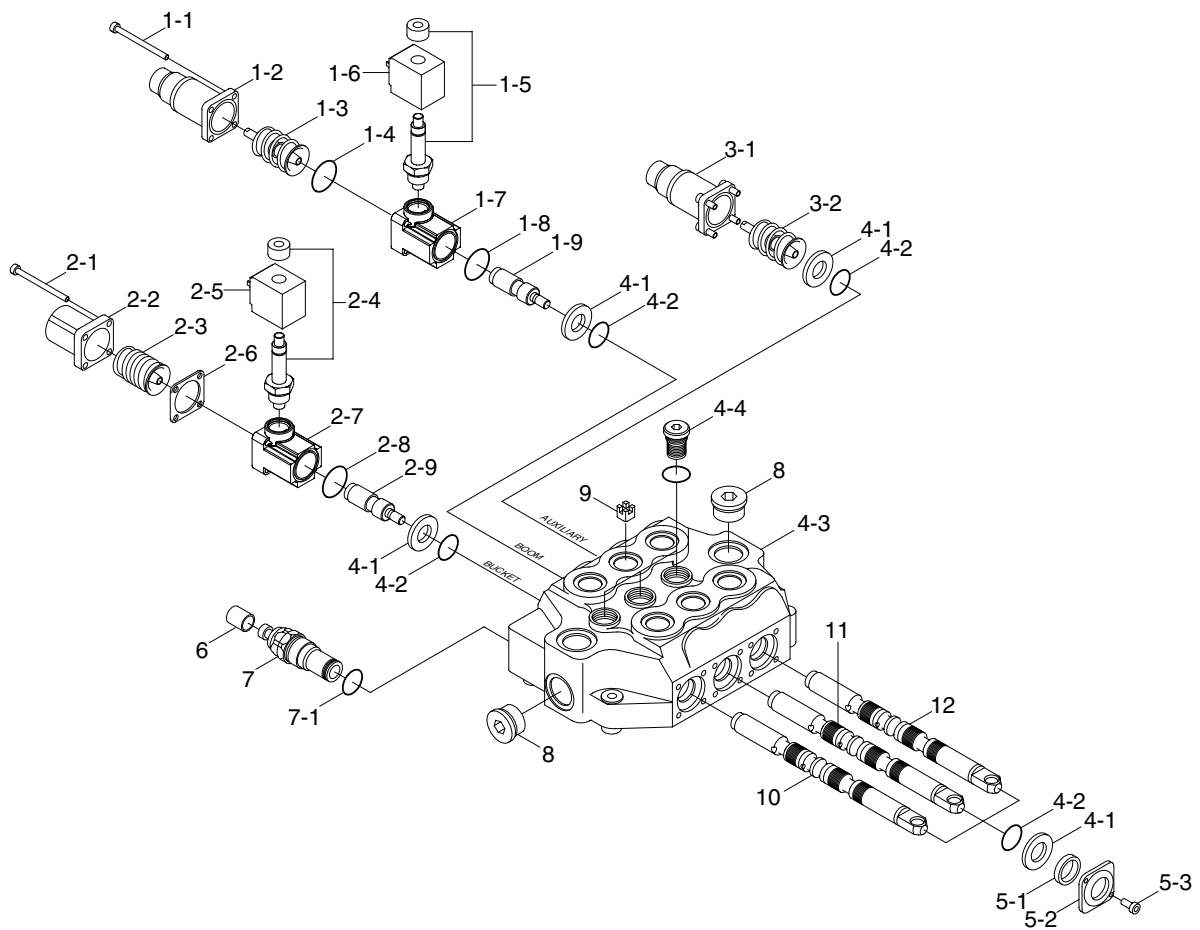

8007HT34

(1) Disassembly

- ① Remove the end cap(3-1) by removing the four mounting screws.
- ② Remove the detent kit(3-2) and ring(4-1), O-ring(4-2).
- ③ Carefully remove the auxiliary spool(12) from the valve body(4-3) and inspect. If spool shows any signs of wear or scoring the entire valve must be replaced.
- ④ Remove the ring(4-1) and the O-ring(4-2) from the valve body(4-3) using care not to scratch the bore and not to contaminate the bore with foreign.
- ⑤ Clean and dry all parts with a suitable solvent. Use petroleum based fuel or mineral spirits.

(2) Assembly

- ① Lubricate the new O-ring(4-2) and ring(4-1) with clean oil. Pinch the lubricate O-ring and insert the O-ring(4-2) and the ring(4-1) into the groove in the front and in the back of the valve. Use care not to cut or nick the O-ring during assembly.
- ② Insert the auxiliary spool(12) to the body(4-3).
- ③ Insert the detent kit(3-2) to end cap(3-1). Assemble the detent kit(3-2) and tighten torque to $2.5\text{kgf} \cdot \text{m}$ ($7.38\text{lb} \cdot \text{ft}$).
- ④ After assembly check for operation of the spring by pushing down on the detent. This should compress the spring and should return when released. Apply grease(Castrol spheerol TN) to the spring and bushes.
- ⑤ Place the end cap(3-1) over the assembly and install the mounting screws and tighten torque to $0.7\text{kgf} \cdot \text{m}$ ($54.2\text{lb} \cdot \text{ft}$).

4) LOAD CHECK VALVE

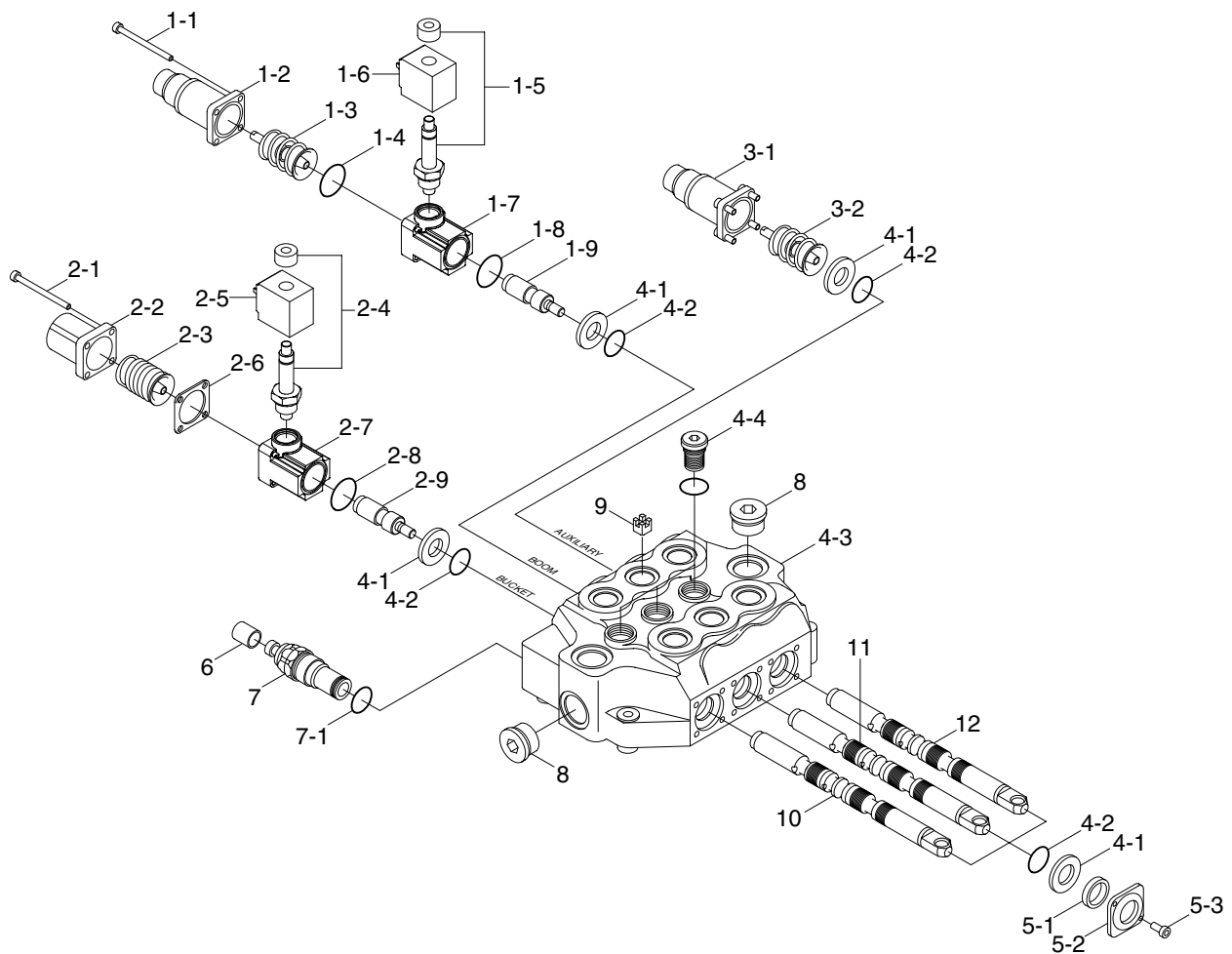

8007HT34

(1) Disassembly

- ① Locate the check valve(4-4, 3position) on top surface of the main control valve.
- ② Remove the check valve kit(4-4).
- ③ Remove and discard the O-ring from the valve kit(4-4).

(2) Assembly

- ① Clean all parts with a suitable solvent and dry all the parts.
- ② Lubricate the new O-ring with clean oil and install onto the valve kit(4-4).
- ③ Install the valve kit(4-4) into the control valve and tighten torque to $3.1\text{kgf} \cdot \text{m}$ ($22.4\text{lbf} \cdot \text{ft}$).

5) MAIN RELIEF VALVE

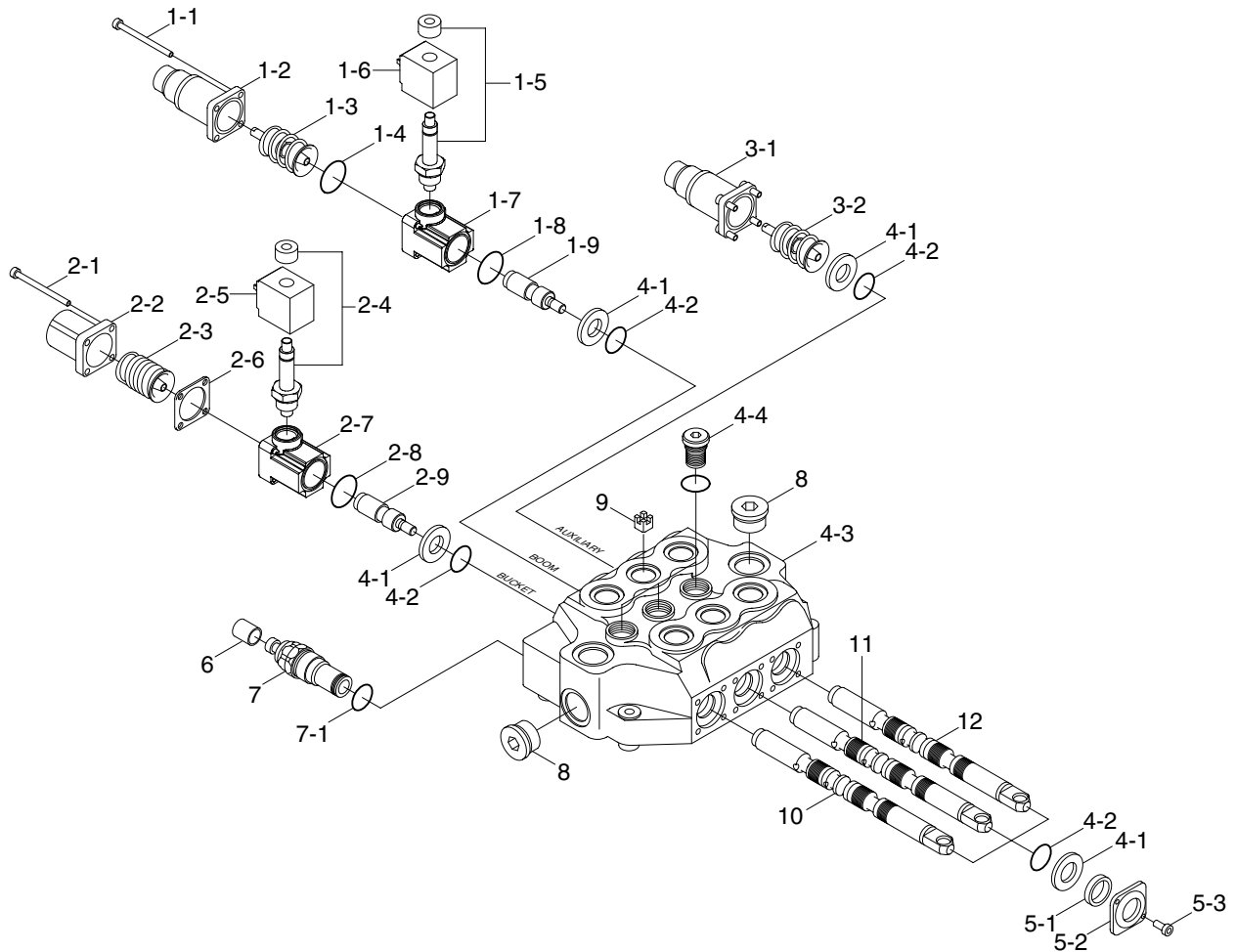

8007HT34

(1) Disassembly

- ① Remove the main relief valve(7).
- ② Remove and discard the O-ring(7-1) from the main relief valve assy(7).

(2) Assembly

- ① Lubricate the new O-ring with clean oil and install onto the main relief valve(7).
- ② Install the main relief valve into the valve body(4-3) and tighten torque to $4.3\text{kgf} \cdot \text{m}$ ($31.1\text{lbf} \cdot \text{ft}$).