

SECTION 5 CONTROL

Group 1 Hand control	5-1
Group 2 Parking brake	5-4
Group 3 Attachment holder	5-5

SECTION 5 CONTROL

GROUP 1 HAND CONTROL

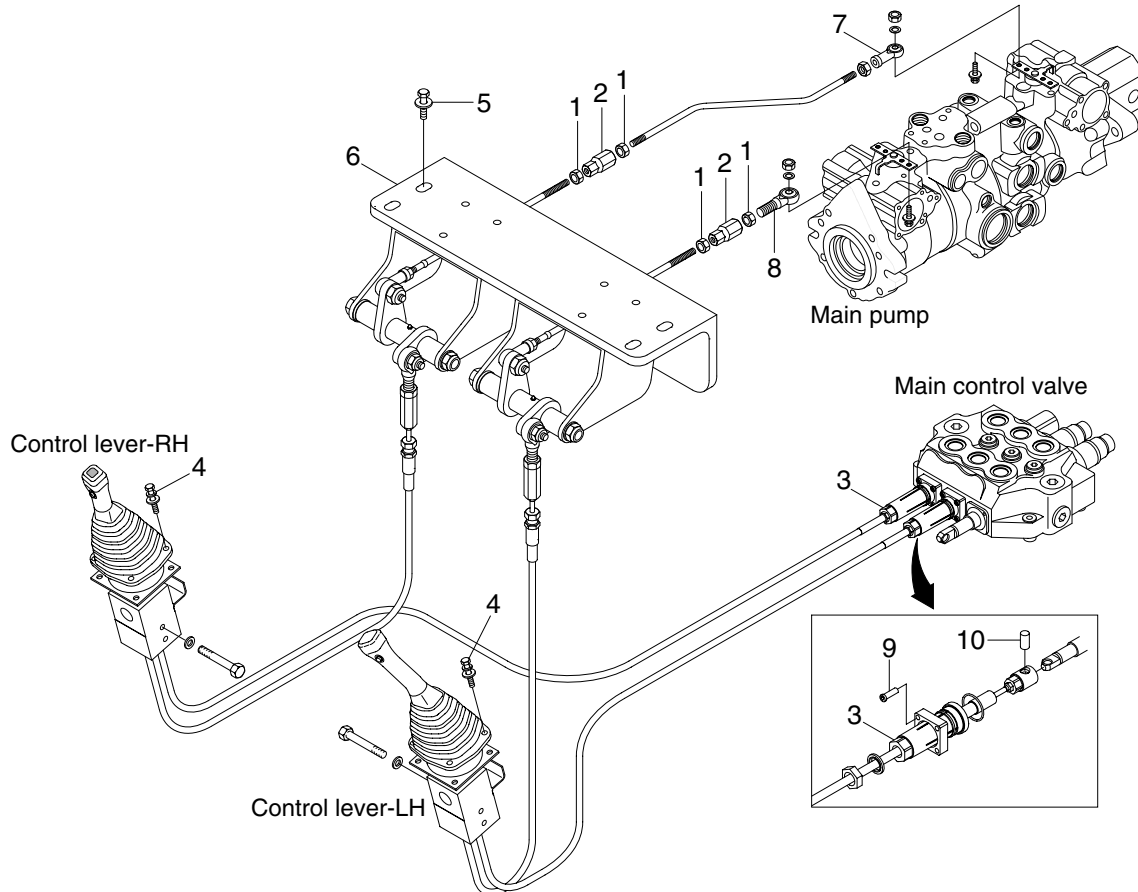

8007CN01

1. ADJUSTMENT OF NEUTRAL

- 1) Stop the loader on a level surface and push throttle lever to low.
 - 2) Raise the canopy to service position.
Refer to operator's manual at page 4-15.
 - 3) Loosen lock nuts(1) to allow adjust nut(2) to move.
 - 4) Adjust neutral position by turn adjust nut(2,3) slowly to left and right.
※ **Neutral position means the state in which the equipment should not move and generate noise to minimum without moving reduction gear and hand lever.**
- ▲ **To prevent unexpected movement of the loader, keep parking position of seat bar.**
- 5) Tighten lock nuts(1) after apply loctite.

2.REMOVAL

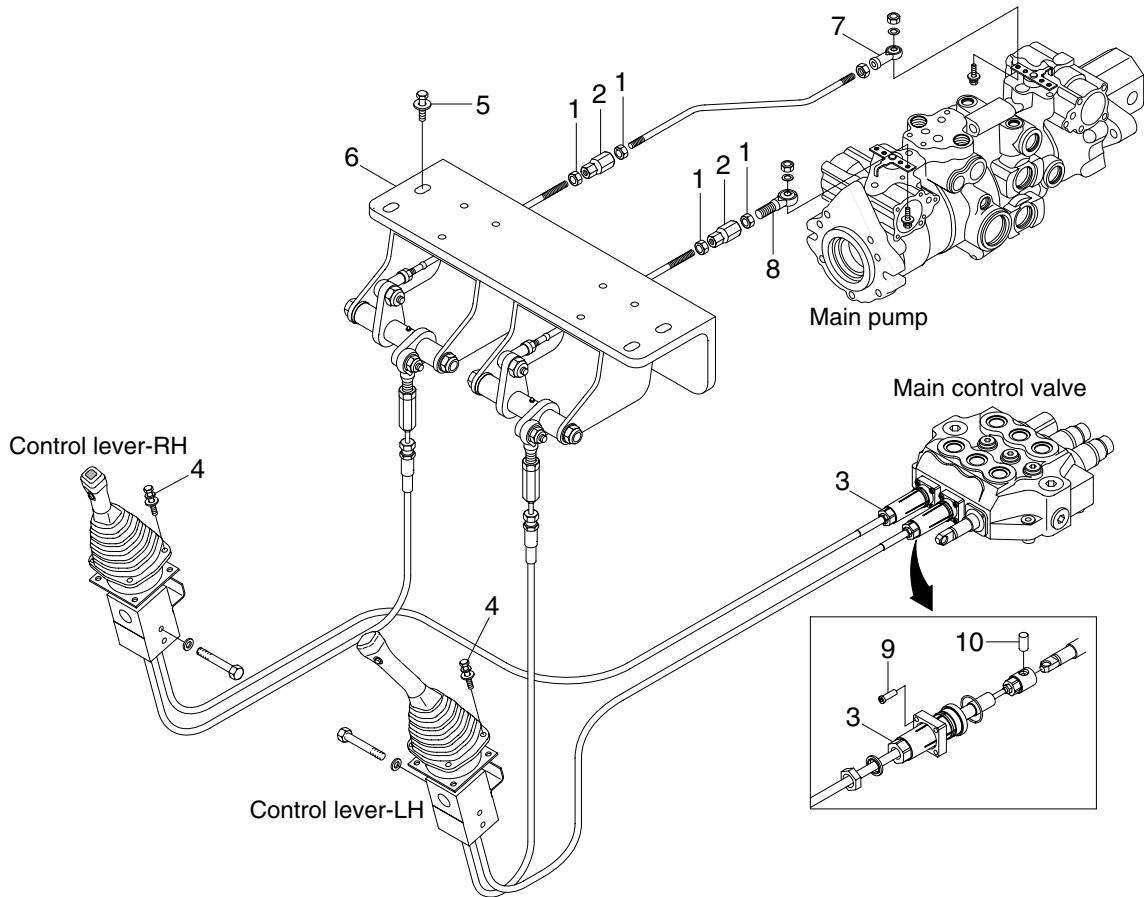

8007CN01

※ **Be sure engine turn off and boom and bucket lowered on ground before removal and installation work of hand control device.**

- 1) Low boom and bucket on ground and block the loader securely with four wheels clear of the ground.
- 2) Raise the canopy to service position.
Refer to operator's manual at page 4-15.
- 3) Remove the console box(LH and RH).
- 4) Remove bolts(4)secure to robber boots.
- 5) Loosen cover bolts(5) and remove cover(6).
- 6) Remove the rod end (7,8) from the pump.
- 7) Remove the bolt(9) and pin(10)from the main control valve.

3. INSTALL

※ Carry out installation in the reverse order to removal.

- 1) Install hand control lever assembly.
- 2) Secure the pin on the main control valve and install adjust cover.
Tighten the bolt.
- 3) Secure the rod end on the main pump.
- 4) Install cover and cover bolts.
- 5) Adjust neutral position by procedure described on chapter 1. **ADJUSTMENT OF NEUTRAL.**

