

SECTION 8

MAINTENANCE & SPECIFICATIONS

Maintenance 8.1

Preventative Maintenance Schedule.....	pg. 8-2
Service Access.....	pg. 8-3 ~ 4
Daily Service.....	pg. 8-5
50 Hour Service.....	pg. 8-6 ~ 7

Trouble Shooting 8.2

Hydrostatic Drive.....	pg. 8-8
Hydraulic System.....	pg. 8-9
Final Drive.....	pg. 8-8
Parking Brake.....	pg. 8-8
Control Levers.....	pg. 8-10
Electrical.....	pg. 8-10
Diesel Engine.....	pg. 8-11

Special Tools 8.3

Descriptions & P / N's.....	pg. 8-12 ~ 15
-----------------------------	---------------

Specifications 8.4

Loader Specifications.....	pg. 8-16 ~ 17
Torque Chart / Specifications.....	pg. 8-18

Decals 8.5

Locations & P / N's.....	pg. 8-19 ~ 26
--------------------------	---------------



MAINTENANCE 8.1

8.1 Preventative Maintenance Service Schedule

ITEM	SERVICE REQUIRED	8 HOURS	50 HOURS	150 HOURS	300 HOURS	1000 HOURS
Engine Oil	Check level. If necessary add 10W30 API Classification CF oil.					
Radiator (Water cooled only)	Check level. If necessary fill with 50 / 50 mixture of ethylene glycol and water. Check for leaks, dirt build up and bent cooling fins. If necessary, straighten cooling fins and clean radiator with compressed air (40psi [27Kpa] max) or flush with water.					
Hydraulic Oil	Check level. If necessary add 10W30 API Classification SJ oil.					
Oil Cooler	Check cooling fins for obstruction. Clean with compressed air or water.					
Air Cleaner	Check air restriction sensor wiring connection. Replace filter elements as required when the air restriction indicator illuminates on the dash panel.					
Tires and Wheels	Check tires for pressure and damage. Inflate standard tires to 50 psi (345 kPa), flotation tires to 40 ~ 45 psi (276 ~ 310 kPa). Torque wheel nuts to 100 ~ 110 ft lbs (136 ~ 149 Nm).					
Safety Equipment	Check the following safety equipment for proper operation and condition: Seat belt, restraint bar, hydraulic control locks, parking brake, boom supports, quick-tach locks, side screens, glass, shields and safety treads. Repair or replace as needed.					
Decals	Check for damaged or missing safety and instruction decals. See Section 8.5. Replace decals as required.					
Lubrication	Grease all hinge pin fittings until excess shows.					
50 Hour Service	Perform complete 50 hour service. See Section 8.2, pg. 8-8.					
Preventative Maintenance	It is recommended as a preventative maintenance that the 50 hour service be repeated every 150 hours after the initial 50 hour service. See 8.2, pg. 8-8.					
Engine Fuel Filter	Replace the engine fuel filter. See Section 7.1.					
Hydraulic Reservoir	Change the hydraulic oil and replace the suction element. Replenish reservoir with 10W30 API Classification SJ oil. See Section 1.7.					
Final Drive	Change the final drive lubricating oil. See Section 3.2.					
Engine Cooling System	Drain, flush and replenish the engine coolant. See Section 7.1.					

Note: For complete engine service details refer to Section 7 of this manual. If further information is required refer to the engine manufacturers service manual.



MAINTENANCE 8.1



WARNING

To avoid personal injury, service repairs must be performed by an authorized Thomas dealer.

8.1.2 SERVICE ACCESS

1. 2A Boom Support

For safety while performing regular service or maintenance work, the loader is equipped with boom support pins. The boom support pins when extended prevent the boom arms from dropping if hydraulic pressure is relieved or the hydraulic controls are accidentally cycled.

IMPORTANT

Fully retract boom support pins before raising or lowering boom arms.

To operate the boom support, first remove any bucket or attachment from the quick - tach; raise the boom arms to full height. Raise the boom support handle (fig. C693) up and push out toward boom arms to extend the boom support pins (fig. C694) Slowly lower the boom arms down on to the pins.



WARNING

To avoid personal injury: Do not leave boom arms up unless the boom supports are engaged.

1. 2B Seat Removal

The seat and seat plate can be removed to provide access to the controls, hydraulic and hydrostatic components. To remove the seat assembly, remove the fasteners located at the front of the seat. **DISCONNECT THE ELECTRICAL PLUG!** Lift the seat assembly out of the machine. When installing the seat, be sure the seat plate is locked in place at the rear (fig. C4280).

The hydrostatic shield can be by removing the four (4) fasteners (fig.C1131).

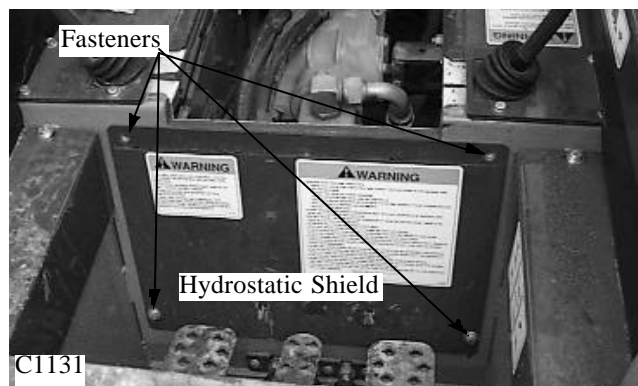
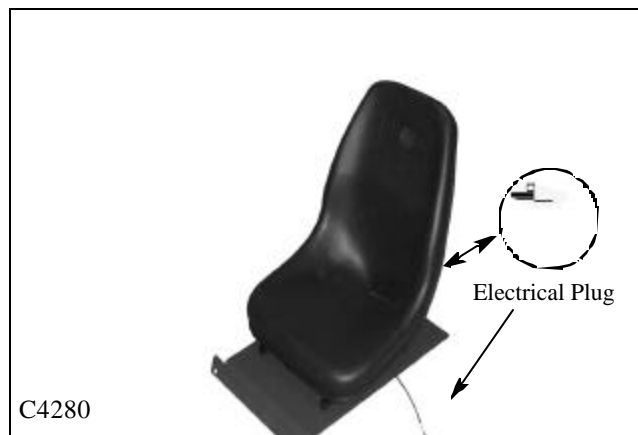
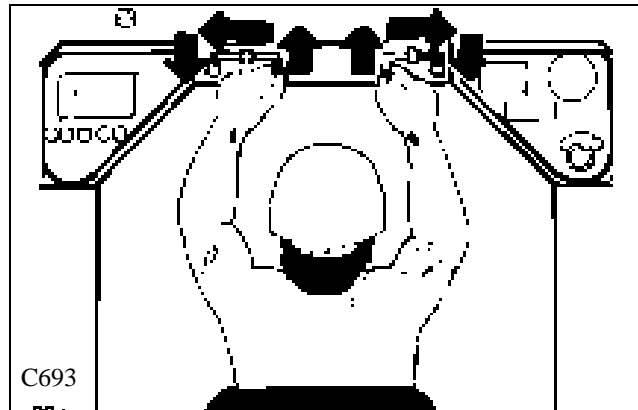

MAINTENANCE 8.1

8.1.2 Service Access

1. 2C Engine Compartment

The engine compartment is completely enclosed for component protection and lockable to discourage vandalism. For servicing the rear door swings open and the engine cover hinges up. To open; raise the door lock handle up clear of the lock plate (fig. C773); pull outward releasing the door catch and swing the door open (fig. C3359). Lower the engine cover before closing the rear door.



IMPORTANT

Keep the rear door closed except for servicing. Make sure the door is closed and latched before operating the loader.

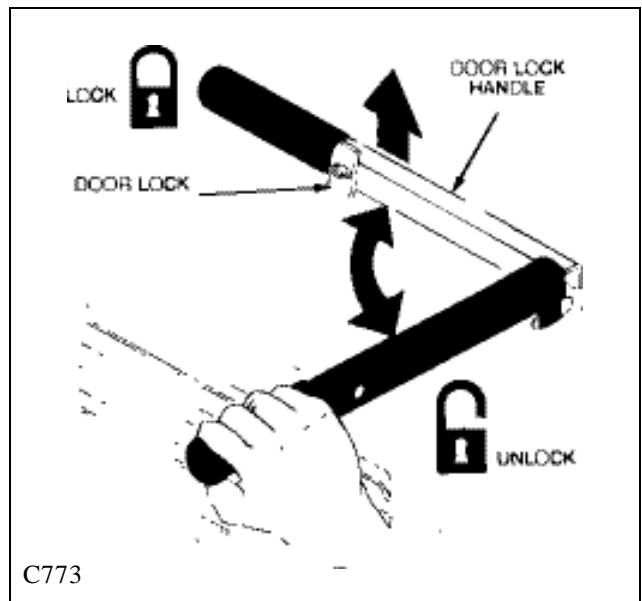

1.2D Universal Joint Access

8

After removal of the operators seat, the U-joint service / inspection panel can be accessed. (fig. C1883) Remove the 2 nuts retaining the panel to the frame, push toward the rear of the loader at the top of the panel, and pull the panel forward and out by the bottom.

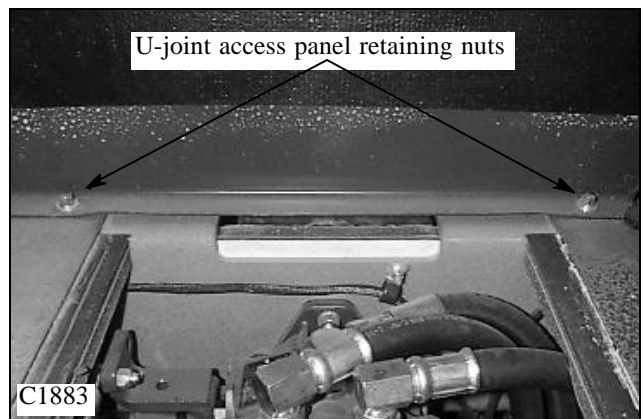

MAINTENANCE 8.1

8.1.3 DAILY SERVICE CHECK

1.3A Radiator Service

With the engine cool remove the radiator cap and check the coolant level. If adding coolant is required fill with a 50% mixture of ethylene glycol and water for cold weather protection.

The radiator cooling fins must be kept free of debris otherwise overheating of the engine will occur. Inspect the radiator cooling fins for damage or buildup of debris. Repair any damage and if necessary flush the radiator with compressed air to remove debris.

1.3B Hydraulic Oil Level

Check the oil level with the machine on a level surface with the lift arms down and the bucket flat on the ground. Open the rear door and check the oil level sight glass (See Section 1). If oil is apparent the oil level is satisfactory.

If necessary to add oil, remove the reservoir cap located at the top of the oil reservoir and add oil until oil appears in the oil level sight glass.

Use a good quality 10W30 oil which meets the API classification SJ only.

1.3C Air Cleaner

The loader is equipped with an air cleaner restriction warning lamp.

Should this lamp illuminate, shut off the engine and determine the cause. Possible plugged air filter.

Check that all hose clamps are tight and the hose is undamaged. Check the vacuator valve for damage.

1.3D Tires and Wheel Nuts

Inspect tires for wear or damage. Check and inflate tires to correct pressure:

7.00 X 15.00 50 psi. (345 kPa)

10.00 x 16.5 . . . 40 - 45 psi (276 - 310 kPa)

To prevent shearing of the wheel studs and rim damage check wheel nuts for proper torque 100 -110 ft lbs(136 - 149 Nm) daily. After changing a rim, check wheel nuts hourly, until the reading stabilizes.

1.3E Safety Equipment

Check all safety equipment for proper operation and condition - seat belt, boom support, seat bar, foot pedal lock, parking brake, quick tach lock, shields and safety treads. Lubricate all linkages, springs and pivot points with a silicone based lubricant. Repair or replace if necessary.

1.3F Decals

Check the condition of all safety and instruction decals. Replace any damaged or missing decals. Refer to section 8.3 for decal description and locations.

1.3G Lubrication

There are sixteen grease fittings located in the loader that require lubrication every eight hours. (See Section 6) Lubricate with a good quality multi-purpose lithium based grease. apply grease until excess shows.

Refer to the service schedule for complete service details. the sixteen lubrication points are:

- Rear Boom Pivots (2)
- Boom Cylinder Bushings (4)
- Bucket Cylinder Bushings (4)
- Boom Supports (2)
- Quick - Tach Pivot and Lock Pins (4)

1.3H Oil Cooler Service

The oil cooler fins must be kept free of debris otherwise over heating of the hydraulic oil will occur. Check the cooler and if necessary remove debris by flushing with compressed air and / or water.

1.3J Engine Oil Level

To check the oil level, stop the engine with the loader on level ground, open the rear door and remove the dipstick.

Keep the oil level between the full and low mark o the dipstick (See Section 7). Do not fill above the full mark – use 10W30 API classification CF oil.



MAINTENANCE 8.1

8.1.4 50 HOUR SERVICE CHECK

The following service check is to be performed by your dealer after the first 50 hours of operation.

1 Engine

1.1 Oil Filter:

Change the engine oil filter. Use only original replacement parts. Refer to section 7 for installation details. Change the oil filter every 150 hours thereafter.

1.2 Engine Oil:

Change the engine oil. Use only 10W30 API classification CF oil. Refer to section 7 for procedure. Change engine oil every 150 hours thereafter.

1.3 Coolant Level:

Check that the coolant is to the proper level. The cooling system is filled with a 50% mixture of ethylene glycol and water.

1.4 Radiator for Leakage and Dirt:

If necessary flush the radiator with compressed air and / or water. (40 psi [27 kPa] max) Dirt buildup on the radiator cooling fins can cause both engine and hydraulic system overheating. Check rubber gasket on radiator to door baffle.

1.5 Fan Belt Tension and Condition:

Check fan belt for cuts or wear, if necessary replace. Check tension and adjust as shown in section 7.

1.6 Fuel System for Leaks:

Make a visual inspection of fuel system for leaks and potential hazards such as fuel line(s) touching exhaust manifold, flywheel, etc. Replace fuel filter every 400 hours.

1.7 Air Intake and Cleaner System:

Follow the manufacturers inspection procedures. Check that the filter indicator is not indicating that filter service is required.

1.8 Exhaust System:

Visually inspect the exhaust system and ensure all clamps are secure and the manifold bolts/nuts are tight. Check muffler for carbon and soot build up and plugging. If necessary clean. Inspect for exhaust leaks.

1.9 Engine Speed:

Check and if necessary adjust engine rpm Maximum no load high idle: 2950 rpm.

1.10 Universal Joint:

Check the condition of the engine universal joints and splines. Lubricate the u-joints with 2 ~ 3 pumps of multi purpose grease.

2 Hydraulic/Hydrostatic

2.1 Hydraulic Oil Filter:

Change the hydraulic oil filter. Change the hydraulic filter every 150 hours after the initial change. Lubricate the filter cartridge seal with system fluid.

2.2 Hydraulic Oil Level:

If oil is visible in the oil level sight glass the level is satisfactory.

If additional oil is required use only 10W30 API classification SJ oil. Fill to the line marked next to the sight gauge.

2.3 Hoses and Pipes:

Make a visual inspection of all hydraulic lines and fittings for leaks. Check that steel lines do not touch one another and clamps are tight.

2.4 Cylinders:

Inspect cylinders for leaks. Extend cylinders and check for rod damage.

2.5 Hydraulic Functions:

Check that the following operate properly: control valve float position, auxiliary hydraulic detent, hydraulic cylinders.

2.6 Pumps & Motors, Leakage:

Inspect pumps and motors for leaks.

2.7 Oil Cooler:

Inspect the oil cooler for leaks, fin damage or clogged with dirt. If necessary flush fins with compressed air and / or water.



WARNING

To avoid personal injury: never repair or tighten hydraulic hoses or fittings with the engine running or the system under pressure.

MAINTENANCE 8.1

3 Final Drive

3.1 Oil Level:

Check lubricating oil level. If necessary add 10W30 API classification SJ- oil.

3.2 Drive Chain Condition:

Check drive chains for any sign of wear or damage. Check lubrication oil in housing for signs of contamination.

3.3 Hydrostatic Motor Mounting Bolts:

Check torque 80 ft lbs (108.2 Nm)

3.4 Axle Bearing End Play:

Axle bearings are pre - loaded and must have no end play. Inspect and adjust if necessary.

4 Controls and Safety Equipment

4.1 Control Levers, Operation and Linkage:

Check that the steering levers operate freely without binding, they return to neutral when released and the machine travels in a straight line with both levers in forward position.

4.2 Hydraulic Controls, Operation and Linkage:

Check that the hydraulic controls operate freely without binding. Before leaving the operator's seat, ensure the controls are locked, raise the safety bar and unbuckle the seat belt. Lubricate or replace as necessary linkage.

4.3 Engine Throttle Control:

Check that the throttle control operates freely without binding or slackening off due to vibration. Check throttle travel to ensure full engagement of high and low engine idle settings.

4.4 Parking Brake:

Check that the parking brake engages and completely disengages. The park brake automatically engages with seat bar up.

4.5 Boom Supports:

Check that the boom supports operate without binding.

4.6 Quick - Tach, Operation & Linkage:

Ensure the quick - tach linkage operates smoothly without binding and the safety locks engage the attachments completely.

4.7 Seat Belt:

Check seat belt condition. If necessary replace.

For your safety, the loader is equipped with electrically activated safety devices through the seat and seat belt. See Section 5.

5 Electrical

5.1 Battery:

Maintenance Free.

5.2 Battery Terminals:

Check battery terminals for corrosion. If necessary, clean.

5.3 Operation of Starter:

Engage and disengage the starter several times to ensure it's working properly. To prevent starter damage do not engage for more than 15 seconds. Allow 1 minute between starting attempts for cooling the starter.

5.4 Operation of Electrical Equipment:

Make a complete check of all electrical equipment, gauges, warning devices, pre-heat indicator, work lights, seat switch and belt and all optional equipment to ensure they are operating correctly.

6 Grease / Lubrication

Lubricate the following points with a good quality grease. Numbers marked () indicate the number of fittings at each location.

Rear Boom Pivots (2)

Boom Cylinder Bushings (4)

Bucket Cylinder Bushings (4)

Engine Universal Joint (2)

Boom Supports (2)

Quick - Tach Pivot and Lock Pin (4)

7 General

7.1 Tire Pressure:

Check the tire pressure and if necessary inflate to the following pressures: 7.00 x 15 @ 50 psi (345 kPa), 10.00 x 16.5 @ 40 - 45 psi (276 - 310 kPa). Flotation tires may be inflated to 50 psi (345 kPa) on hard flat surfaces.

7.2 Wheel Nut Torque:

Check and torque wheel nuts to 100 - 110 ft lbs (136 - 149 Nm).

7.3 Condition of Cab:

Inspect the condition of the ROPS mounting isolators. Replace isolators if deteriorated. Inspect both the seat and seat belt. Ensure all safety and instruction decals are in place. Inspect sound insulation, side windows and door operation for machines equipped with cab enclosure kits.

7.4 Condition of Shields and Safety Equipment:

Inspect and ensure all shields are in place and securely fastened. Inspect and ensure all safety equipment is working properly. Ensure owners and operators manual, safety manual and all safety and instruction decals are in place. If necessary, replace. If the safety controls are malfunctioning or require adjustment consult your **Thomas** Equipment Dealer for service.

7.5 General Condition:

Make a general inspection of the machine looking for loose or missing parts, oil leaks, etc.



TROUBLESHOOTING 8.2

8. 2A Hydrostatic Drive

Symptom	Cause	Remedy
No power on one side (both directions)	Reservoir low on oil	Replenish with 10W30 API SJ oil. Check for hose or fitting leak.
	Disconnected control linkage	Reconnect and adjust linkage.
	Groove pin sheared on pump pintle lever	Replace. Check pintle lever for loose bolt or excessive play.
	High pressure line failure	Replace line. Ensure new line fits without being forced. If necessary stress relieve.
	Drive chain failure Adjust tightener tension.	Replace chain or connection link.
	Motor shaft or key failure Check mounting bolts.	Inspect and repair defective parts. motor
	Excessive internal leakage in and/or motor pump	Inspect and repair defective unit. Flush all lines and tank. Replace filter. Check on type of fluid used and engine rpm.
No power on one side (one direction only)	Defective relief valve	Replace defective valve.
	Damaged ball check	Disassemble and repair.
No power on both sides (also loss of hydraulic power)	Reservoir low on oil	Replenish with 10W30 API SJ. Check for hose or fitting leaks
	Universal Joint failure between engine and pump	Inspect and repair damaged parts. Flush all lines and tank, change filter. Check on type of fluid used and engine RPM
	Damaged ball check	Disassemble and repair
Gradual loss of power as machine warms up	Excessive internal leakage in pump and/or motor	Consult dealer or Thomas Service Dept.

8.2A Hydrostatic Drive

Symptom	Cause	Remedy
System erratic and/or noisy reservoir	Air in system due to low oil level in oil.	Replenish with 10W30 API SJ
	Air in system due to leak at suction fitting	Check fittings and tighten.
	Internal pump or motor wear caused by over speeding	Consult your dealer or Thomas Service Dept.
	Excessive play in linkage or pintle lever	Adjust linkage and tighten or replace pintle lever.
Machine will not travel in a straight line in high range	Control levers binding	Check that shields are not stopping lever from full travel.
		Check for linkage binding at spring mount. Adjust tracking.

8.2B Final Drive Transmission

Symptom	Cause	Remedy
Final drive transmission noisy	No lubricating oil	Check and bring oil to the proper level. Use 10W30 SJ engine oil
	Parking brake damaged or out of adjustment	Inspect and adjust or replace damaged parts
	Axles have too much end play	Pre-load axle bearings removing all end play
	Chain loose	Adjust or replace chain

8.2C Park Brake

Symptom	Cause	Remedy
Brake will not hold machine	Brake valve will not release pressure	Verify position of over-ride
	Brake parts damaged or worn	Consult your Dealer or Thomas Service Dept.
	Brakes are disengaged	Engage parking brake
Brake will not release machine	No power to brake valve solenoid	Check fuse, If fine, consult Dealer or Thomas Service Dept.
	No pressure in supply line to brake valve	Consult your Dealer or Thomas service Dept.
	Brakes are engaged	Release brake

TROUBLESHOOTING 8.2

8.2D Hydraulic System

8.2D Hydraulic System

Symptom	Cause	Remedy
Hydraulic action jerky	Reservoir low on oil	Replenish with 10W30 API or 20W50 SJ oil.
	Air in hydraulic system	Check for leak between reservoir and pump. Bleed System by extending and retracting lift cylinders several times.
	Anti-cavitation check valve not functioning	Inspect and repair or replace
Boom raises slowly at full engine rpm	Reservoir low on oil	Replenish with 10W30 or 20W50 API SJ oil
	Foot pedal linkage binding	Inspect and adjust
	Auxiliary foot pedal engaged	Disengage
	Engine rpm too slow	Check rpm and reset
	Anti-cavitation check valve spring broken	Replace
	Pressure relief valve in control valve faulty	Check pressure if necessary - adjust
	Internal leakage in pump due to wear	Check pump flow and repair or replace as necessary
	Oil bypassing one or both lift cylinder piston seals	Install new piston seal kits
Lift or tilt cylinders will not support a load	External leak between or at control valve and cylinders	Check for leaks and correct
	Control valve spool not centering	Check for sticking foot pedal linkage
		Check for broken or stuck return spring on valve spool
Oil leaking by one or both cylinder piston seals	Install new piston seal kits	
Hydraulic oil overheating	Reservoir low on fluid	Replenish with 10W30 or 20W50 API SJ oil
	Oil cooler plugged or dirty (also check engine radiator)	Clean cooling fins

Symptom	Cause	Remedy
Loss of hydraulic power (no flow from gear pump)	Reservoir low on fluid hose or fitting leak.	Replenish with 10W30 or 20W50 API SJ oil. Check for leaks.
	Universal Joint between engine and pump failure	Inspect and replace damaged parts. Check for misalignment between engine and pumps.
	Spline coupling failure between front and rear hydrostatic pump	Inspect coupling for sheared splines. Also check pump shaft bearings.
	Hydraulic gear pump not functioning	Inspect and repair.
Loss of hydraulic power (flow from gear pump)	Reservoir low on fluid	Replenish with 10W30 or 20W50 API SJ oil
	Foot pedal linkage disconnected or binding	Inspect and adjust.
	Auxiliary foot pedal engaged	Disengage
Hydraulic oil overheating	Relief valve failure in control valve	Check pressure and adjust.
	Auxiliary foot pedal engaged	Disengage
	Engine rpm too slow	Check rpm and adjust
Foot pedals do not operate smoothly	Incorrect temperature sensor	Replace
	Foot pedal linkage out of adjustment	Adjust foot pedal linkages
Foot pedals do not operate smoothly	Foot pedal linkages need lubrication	Lubricate with a silicone based lubricant
	Cable Binding	Check routing for kinks etc.



TROUBLESHOOTING 8.2

8.2E Control Levers

Symptom	Cause	Remedy
Control levers will not center	Linkage out of adjustment	Adjust, check for wear at rod ends, loose counter nuts
	Linkage disconnected	Reconnect, check for wear at rod ends, loose counter nuts
	Centering spring broken	Replace
	Linkage binding	Control levers binding with safety shields or sound insulation Adjust Control lever bearings binding in lever assy. Inspect replace or clean as required
Machine operates erratically	Control lever linkage loose	Inspect linkage for wear at rod ends, loose counter nuts
	Bolt in pintle lever loose or broken	Replace bolt. Ensure bolt clamping lever to pump shaft is tight See troubleshooting hydrostatic system
Machine loses power while turning		See troubleshooting hydrostatic system
Machine will not travel in straight line	Linkage binding	Adjust
	Control lever travel out of adjustment	Adjust
Control levers do not operate smoothly	Internal pump and / or motor leakage	See troubleshooting hydrostatic system
	Control lever linkage out of adjustment	Adjust control lever linkages
	Control lever linkages need lubrication	Lubricate

8.2F Electrical

Symptom	Cause	Remedy
Engine will not crank over	Battery failure	Check battery, charge or replace
	Battery cable failure	Check for loose or corroded connectors. tighten and clean as required. Use dielectric grease to prevent corrosion. Check continuity of cables and replace if defective
	Starter failure	Repair or replace
	Fuse burnt	Check and replace
	Defective relay	Check relay continuity if defective, replace
	Ignition switch failure	Check continuity and if defective, replace
Engine cranks over, but will not start	Auxiliary hydraulics engaged	Engine will smoke but not run unassisted by starter. Disengage aux. hydraulics
	Defective glow plug relay	Check continuity and if defective, replace
	Defective glow plugs	Check continuity and if defective, replace
	Broken connection or defective wire	Check continuity of the circuit not functioning properly in both engine and ROPS harness.
	No fuel	Check fuel levels and system
Loader starts, but hyd. controls will not release	Electric solenoid not releasing valve spools	Defective solenoid or binding solenoid lock.
		Check continuity of connectors and wire.
Engine will not stop when the key is turned OFF	Defective ignition switch	Check and replace
	Mechanical damage of the governor	Check and repair or replace









TROUBLESHOOTING 8.2

8.2G Diesel Engine

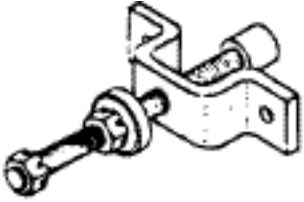

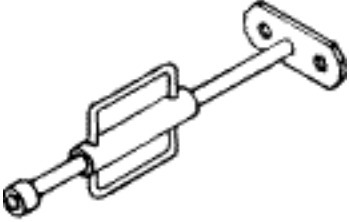

Symptom	Cause	Remedy
Engine does not start	No fuel	Replenish fuel
	Air in the fuel	Vent air
	Water in the fuel	Change fuel and repair or replace fuel system
	Fuel pipe clogged	Clean
	Fuel filter clogged	Clean or change
	Excessively high viscosity of fuel or engine oil at low temperature	Use the specified fuel or engine oil
	Fuel with low octane number	Use the specified fuel
	Fuel leak due to loose injection pipe retaining nut	Tighten nut
	Incorrect injection timing	Adjust
	Fuel cam shaft worn	Replace
	Injection nozzle clogged	Clean
	Injection pump malfunctioning	Repair or replace
	Seizure of crankshaft, camshaft, piston, cylinder liner or bearing	Repair or replace
	Compression leak from cylinder	Replace head gasket, tighten cylinder head bolt, glow plug and nozzle holder
	Improper valve timing	Correct or replace timing gear
	Piston ring and liner worn	Replace
Excessive valve clearance	Adjust	
Starter does not run	Battery discharged	Charge
	Starter malfunctioning	Repair or replace
	Key switch malfunctioning	Repair or replace
	Wiring disconnected	Connect
Engine revolution is not smooth	Fuel filter clogged or dirty	Clean or change
	Air cleaner clogged	Clean or change
	Fuel leak due to loose injection pipe retaining nut	Tighten nut
	Injection pump malfunctioning	Repair or replace
	Incorrect nozzle opening pressure	Adjust
	Injection nozzle stuck or clogged	Repair or replace
	Fuel overflow pipe clogged	Clean
Governor malfunctioning	Repair	
Either white or blue exhaust gas is observed	Excessive engine oil	Reduce to the specified level
	Low grade fuel used	Repair or replace
	Fuel filter clogged	Clean or change
	Air cleaner clogged	Clean or change
Either black or dark gray exhaust gas is observed	Overload	Lessen the load
	Low grade fuel used	Use the specified fuel
	fuel filter clogged	Clean or change
	Air cleaner clogged	Clean or change



SPECIAL TOOLS 8.3

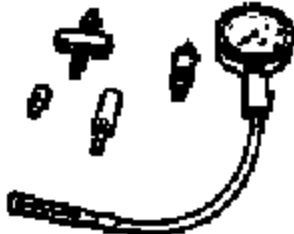





P / N	Illustration	Description	Model
955280		AXLE INSTALLATION TOOL - To install axle in final drive housing. Quantity - 1	T103 T135 T133'S' T137'S' T153'S'
955281		SEAL INSTALLATION TOOL - To install axle seal in final drive housing. Quantity - 3 required	T103 T135 T133'S' T137'S' T153'S'
955283 (6 Bolt) 960475 (8 Bolt)		AXLE EXTRACTOR TOOLS - To remove axle from final drive housing. Quantity - 1	ALL MODELS
955287		SEAL INSTALLATION TOOL - To install axle seal in final drive housing. Quantity - 1	T173 T233
957189		SEAL INSTALLATION TOOL - To install axle seal in final drive housing. Quantity - 1	T173HL T173HLS' T173HL'S'II T203HD T233HD T243HD'S
960997		CHAIN TENSION TOOL - To test chain tension.	T103 T135 T133'S' T137'S' T153'S'

SPECIAL TOOLS 8.3

P / N	Illustration	Description	Model
916-30042-01 25197		<p>DRY LINER PULLER - Used for removing and installing the dry liner of the engine.</p> <p>Consists of: 304742 (64mm); 304743 (68mm); 30744 (75mm) 304745 (76mm); 304746 (82mm); 304747 (105mm); Removing Plates; 304748 Installing Plate</p>	Kubota
07909-30202-01 25198		<p>DIESEL ENGINE COMPRESSION TESTER - Used to measure diesel engine compression and diagnosis of need for major overhaul.</p>	Kubota
07916-30820-01 25199		<p>CRANKSHAFT NUT SOCKET - Used to take off and fix the crankshaft nut. (46 mm).</p>	Kubota
07916-30840-01 25200		<p>NOZZLE REMOVER SOCKET - Used to unfasten the screw type nozzle holders.</p>	Kubota
70090-01125-01 25201		<p>NOZZLE DISASSEMBLY SOCKET - Used in place of a vice for disassembly and repair of nozzles.</p>	Kubota
960456		<p>HYDRAULIC FLOW AND PRESSURE GAUGE ASSEMBLY.</p>	All Loaders



SPECIAL TOOLS 8.3

P/N	Illustration	Description	Model
43979	 <p>C1840</p>	CHAIN PULLER	ALL MODELS
43980	 <p>C1841</p>	SPANNER WRENCH 2'' - 4 3/4'' To repair hydraulic cylinders	ALL MODELS
43981	 <p>C1837</p>	PHOTO SENSOR / WHEEL SPEED TACHOMETER (Dual Function)	ALL MODELS
	 <p>C1839</p>	FORCE GAUGE, PUSH PULL For measuring restraint bar brake cable adjustment. Special order only	T173HLS T173HLS II T243HDS T245HDS
	 <p>C2342</p>	MULTI METER For measuring continuity, voltage, etc.	ALL MODELS
	 <p>C2343</p>	ANGLE FINDER For measuring control angles, U-joint and chassis angles etc.	ALL MODELS

NOTES



THOMAS



SPECIFICATIONS 8.4

LOADER SPECIFICATIONS

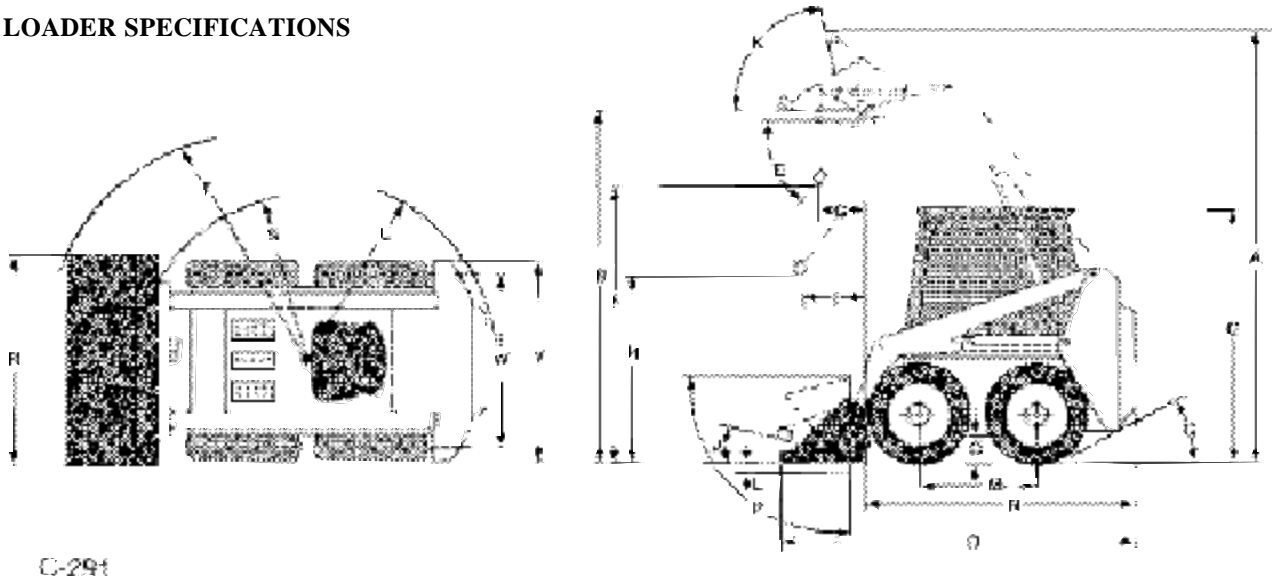

C-294

Dimensions : (With Standard Tires & Dirt Bucket)

	153	137/135/1300
A. Overall operating height	138" (3505.2)	137 3/4" (3498.9)
B. Height to hinge pin	110" (2781)	110" (2794)
C. Overall vehicle height	73.5" (1867)	73.5" (1867)
D. Overall length with bucket	127.8" (3246.1)	127.8" (3246.1)
E. Dump angle	35°	35°
F. Dump height	89.8" (2280.9)	89.8" (2280.9)
G. Reach — fully raised	23.8" (604.5)	23.8" (604.5)
H. Height at 45° dump angle	73.5" (1866.9)	73.5" (1866.9)
I. Reach at 45° dump angle	28" (711.2)	28" (711.2)
J. Maximum roll back at ground	27°	27°
K. Maximum roll back fully raised	96°	97°
M. Wheel base	35" (889)	35" (889)
N. Overall length less bucket	104.4" (2651.8)	104.4" (2651.8)
O. Ground clearance	7.5" (190.5)	7.5" (190.5)
P. Maximum grading angle – bucket	90°	90°
Q. Angle of departure	23°	28°
R. Bucket width	60" (1524)	60" (1524)
S. Clearance circle – front – less bucket	48" (1219.2)	48" (1219.2)
T. Clearance circle – front – with bucket	72.6" (1844)	72.6" (1844)
U. Clearance circle – rear	61.9" (1572.3)	61.9" (1572.3)
V. Overall width – less bucket	57.5" (1460.5)	57.5" (1460.5)
W. Tread	46.6" (1183.64)	46.6" (1183.64)
Operational:		
Tipping capacity SAE	3000 lbs. (1360.7 kg)	2600 lbs. (1180 kg)
Rated operating capacity	1500 lbs. (682 kg)	1300 lbs. (590 kg)
Operating weight	5700 lbs. (2585 kg)	5350 lbs. (2477 kg)
Shipping weight	5350 lbs. (2427 kg)	4830 lbs. (2191 kg)
Travel speed	0-6.2 mph (0-9.9 km/h)	0-6.2 mph (0-9.9 km/h)



SPECIFICATIONS 8.4

Controls

Vehicle: Steering direction and speed controlled by two hand operated control levers.

Hydraulics: Lift and bucket tilt are controlled by separate foot or hand controls. Auxiliary hydraulics controlled by foot pedal.

Engine: Hand throttle, key type ignition switch and shutoff.

Engine	153	137/135/1300
Make and model	Kubota V2203E.....	Kubota V1903E
Cylinders	4.....	4
Cooling system	Liquid.....	Liquid
Displacement	134 cu in (2197cc).....	113.3 cu in (1857cc)
Horsepower (Gross).....	50.....	42
Power (ISO 9249 Net Power).....	34.3 kW (46 hp).....	29 kW (39 hp)
Power (ISO 9249 Net Power) CE	34.3 kW (46 hp).....	29 kW (39 hp)
Max Torque	115 ft lbs (15.9 kg/m).....	96 ft lbs. (13.25 kg/m)
Fuel type		Diesel No. 2
Air cleaner.....		Replaceable dry cartridge w / Indicator
High Idle rpm	2800.....	2800
High Idle rpm, CE	2600.....	2600

Hydraulic System

Pump type			Gear
Pump Capacity (theoretical).....	@2800 16.6 gpm (75.5 l/min).....	@2600 15.4 gpm (70 l/min)	
Control valve			Series type with float on lift and detent on auxiliary
Filtration			5 micron
Hydraulic fluid			10W30 API Class, SJ
Control valve			Series type with float on lift and detent on auxiliary
Oil cooler			674 BTU (711 kCal)
Cylinders.	Lift (153).....	Lift (137/135/1300)	Tilt (All)
Type.....	Double acting.....	Double acting.....	Double acting
Qty per loader	2.....	2.....	2.....
Bore diameter	2.5 in.....	2 in.....	2.5 in.....
Rod diameter	1.5 in.....	1.25 in.....	1.125 in.....
Stroke	27.125 in.....	27.125 in.....	13.375 in ..

Hydrostatic Transmission & Final Drive

Pump type		Two in line, axial piston pumps
Pump displacement		2. 65 cu in (43.5 cm ³)
Motor type		Geroler
Motor displacement		31.9 cu in (523.6 cm ³)
System relief setting		5000 psi (345 Bar)
Final drive		Single roller chain running in oil bath to each axle
Drive chain size		ASA 100

Electrical

153/137/135/1300

Alternator	40 A
Battery	1 x 12V
Type (BCI GROUP).....	34/78
Cranking Amps	730
Starter	12 V (1.4 kW)
Circuit breaker rating	40 A



SPECIFICATIONS 8.4

Torque Specifications

Loader

Wheel nuts (24)	100 - 110 ft lbs. (136 - 139 Nm)
Chain tightener adjuster nuts (6)	150 ft lbs. (203 Nm.)
Motor mount isolators (4)60 ft lbs (81.6 Nm)

FOR NON-CRITICAL AND NOT OTHERWISE MENTIONED APPLICATIONS. THE FOLLOWING GENERAL ASSEMBLY TORQUES WILL APPLY:

<i>Bolts & Nuts</i>	<i>Torque ft. lbs (Nm.)</i>		
1/4 - 20	5 - 7 (6.7 - 9.5)	7/16 - 20	40 - 45 (54 - 61)
5/16 - 18	12 - 15 (16 - 20)	1/2 - 13	45 - 50 (61 - 68)
5/16 - 24	12 - 15 (16 - 20)	1/2 - 20	50 - 60 (68 - 81)
3/8 - 16	17 - 22 (23 - 30)	9/16 - 12	60 - 70 (81 - 95)
3/8 - 24	22 - 27 (30 - 37)	9/16 - 18	65 - 75 (88 - 102)
7/16 - 14	30 - 35 (41 - 47)	5/8 - 11	75 - 85 (102 - 115)
		5/8 - 18	100 - 110 (136 - 150)

Hydraulic Fittings: Specifications listed in ft lbs. Multiply by 1.36 for Nm.			
HOSE SIZE	37° JIC FITTINGS	HOSE SIZE	ORB FITTINGS
1/4	9 to 10	1/4	14 to 16
5/16	15 to 16	5/16	18 to 20
3/8	20 to 22	3/8	24 to 26
1/2	30 to 33	1/2	50 to 60
5/8	40 to 44	5/8	72 to 80
3/4	70 to 77	3/4	125 to 135
7/8	82 to 90	7/8	160 to 180
1	55 to 60	1	200 to 220
1 1/4	120 to 132	1 1/4	210 to 280
1 1/2	131 to 144	1 1/2	270 to 360
2	300 to 330		

The following torque specifications are for steel ORB fittings into aluminum.			
HOSE SIZE	ORB FITTINGS	HOSE SIZE	ORB FITTINGS
1/4	5 to 7	3/4	40 to 45
5/16	8 to 10	7/8	50 to 55
3/8	10 to 12	1	90 to 99
1/2	21 to 24	1 1/4	80to 90
5/8	27 to 30		



Tandem Pump		
Description	Qty.	Specification
Front Support	1	50 (+/- 2)
Rear Mounting	2	60 (+/- 2)
Trunion Seal Carrier	4	20 (+/- 2)
Trunion Seal Cover	4	20 (+/- 2)
Relief Valve	4	40 (+/- 10)
Charge Relief Cap	1	40 ~ 100
Tandem Section	4	40 (+/- 5)
Gear Pump	2	25 (+/- 2)

Torque Motor		
Description	Qty.	Specification
Valve Housing	4	130
Bearing Housing	8	46.5
Front Cover	8	10.7
Bearing Nut	1	45
Mounting	4	80

DECALS 8.5

135S/137/153 DECAL CHART

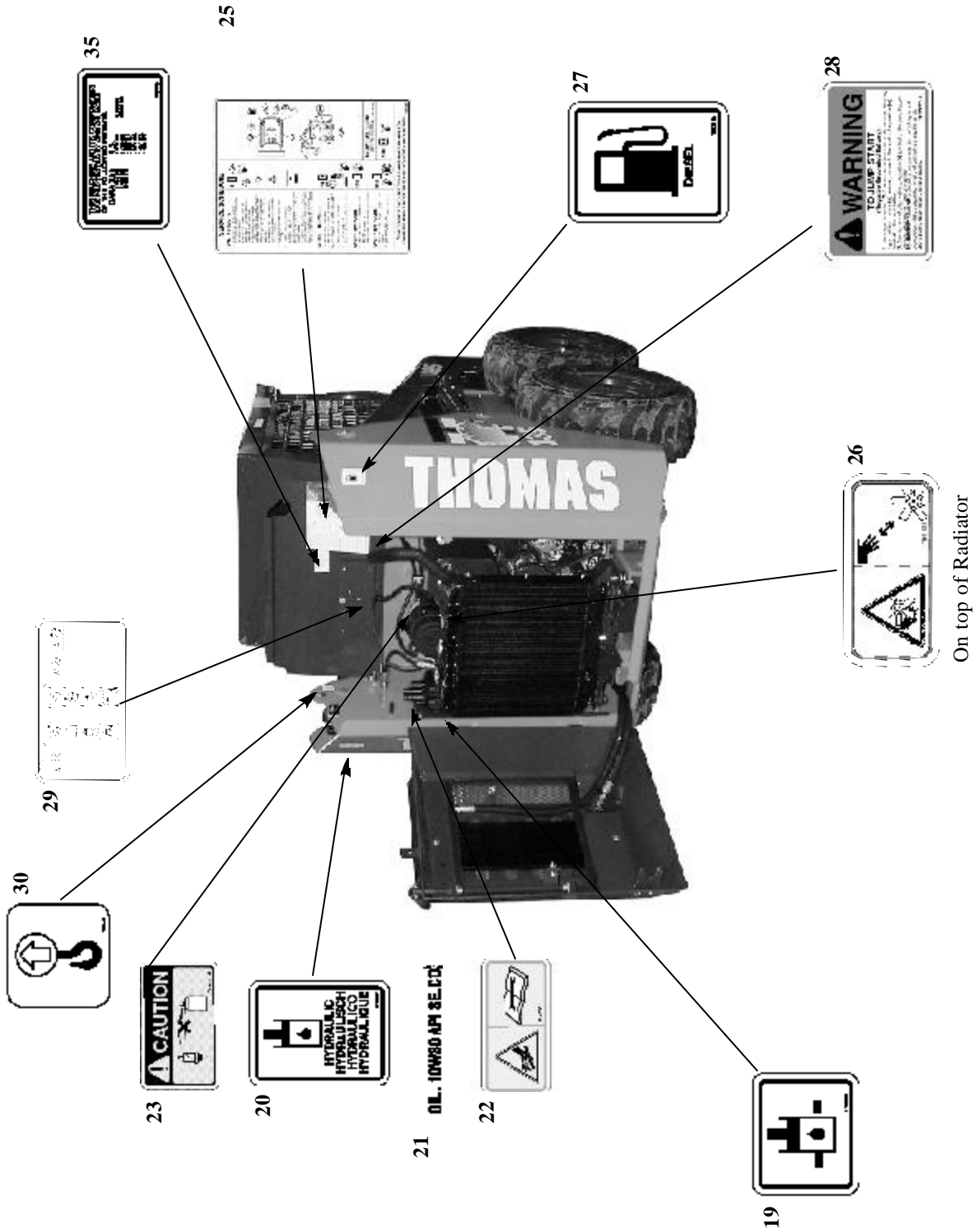

DECALS 8.5

135S/137/153 DECAL CHART

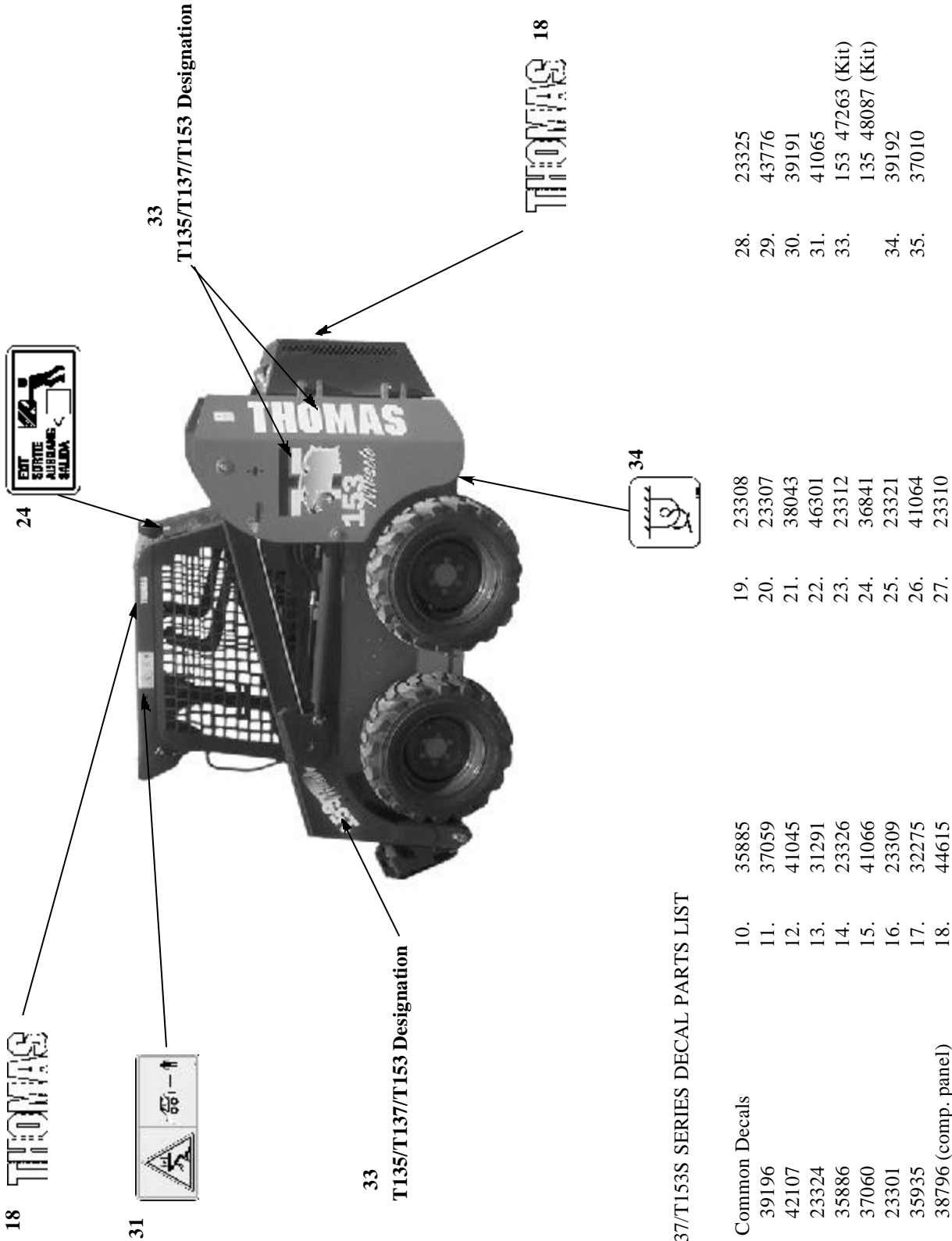

T135S/T137/T153S SERIES DECAL PARTS LIST

49273 Common Decals	10.	35885	19.	23308	28.	23325
1. 39196	11.	37059	20.	23307	29.	43776
2. 42107	12.	41045	21.	38043	30.	39191
3. 23324	13.	31291	22.	46301	31.	41065
4. 35886	14.	23326	23.	23312	33.	153 47263 (Kit)
5. 37060	15.	41066	24.	36841	34.	135 48087 (Kit)
6. 23301	16.	23309	25.	23321	35.	39192
7. 35935	17.	32275	26.	41064		37010
8. 38796 (comp. panel)	18.	44615	27.	23310		
9. 36598						



NOTES



8

THOMAS

DECALS 8.5

5.3 ProTough 1300 DECAL CHART

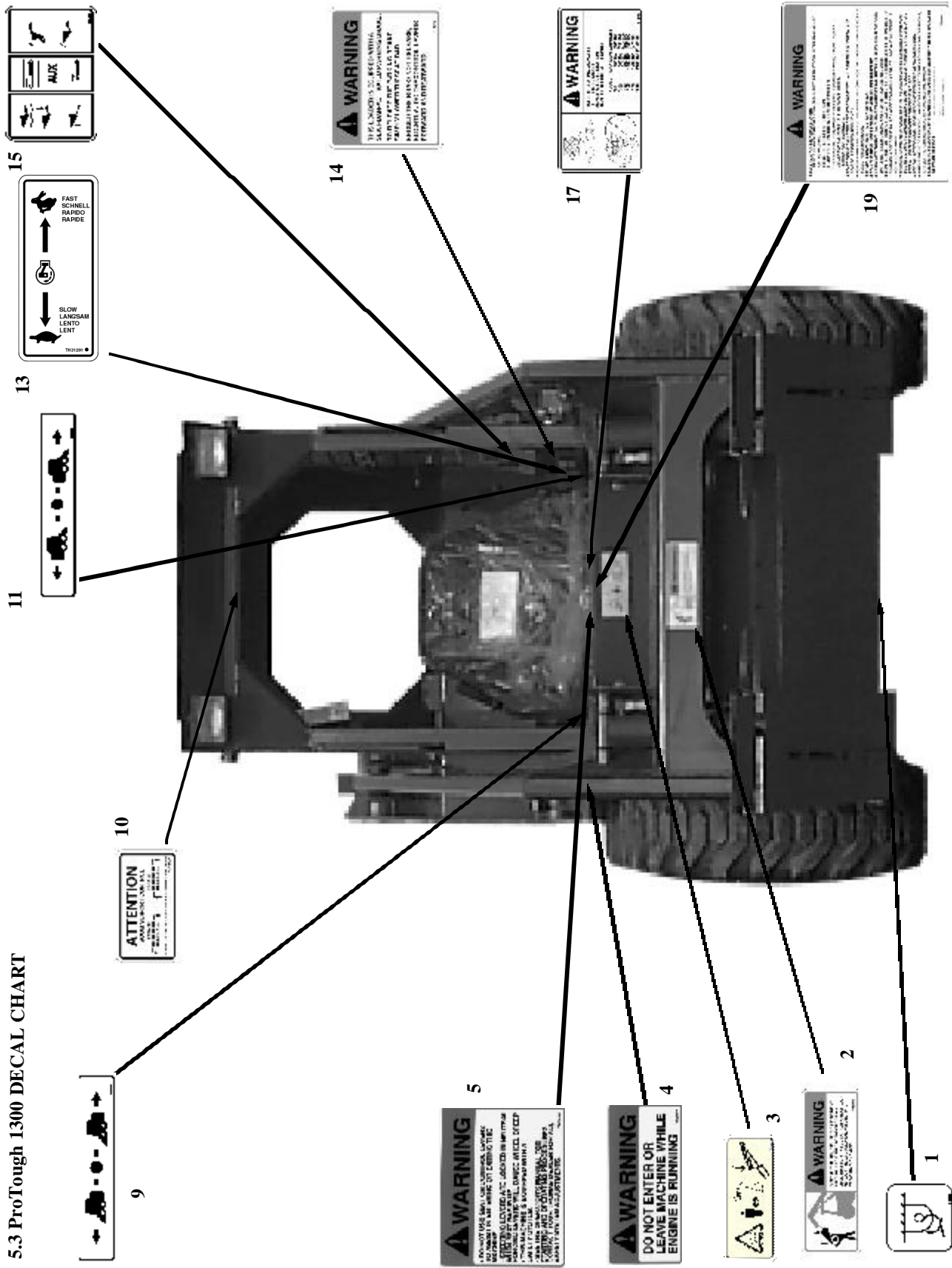



5.3 ProTough 1300 DECAL CHART

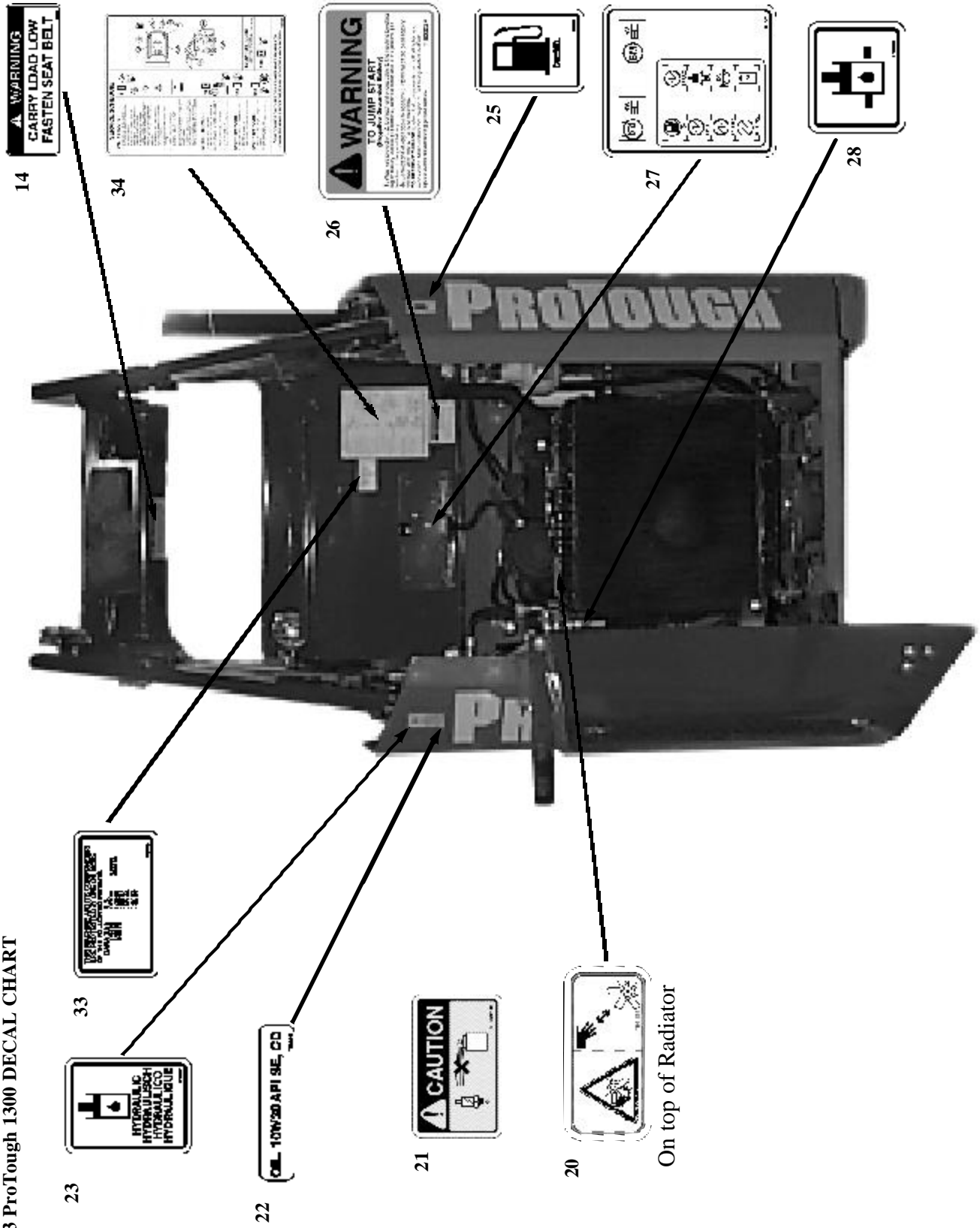

DECALS 8.5

DECALS 8.5

5.3 ProTough 1300 DECAL CHART

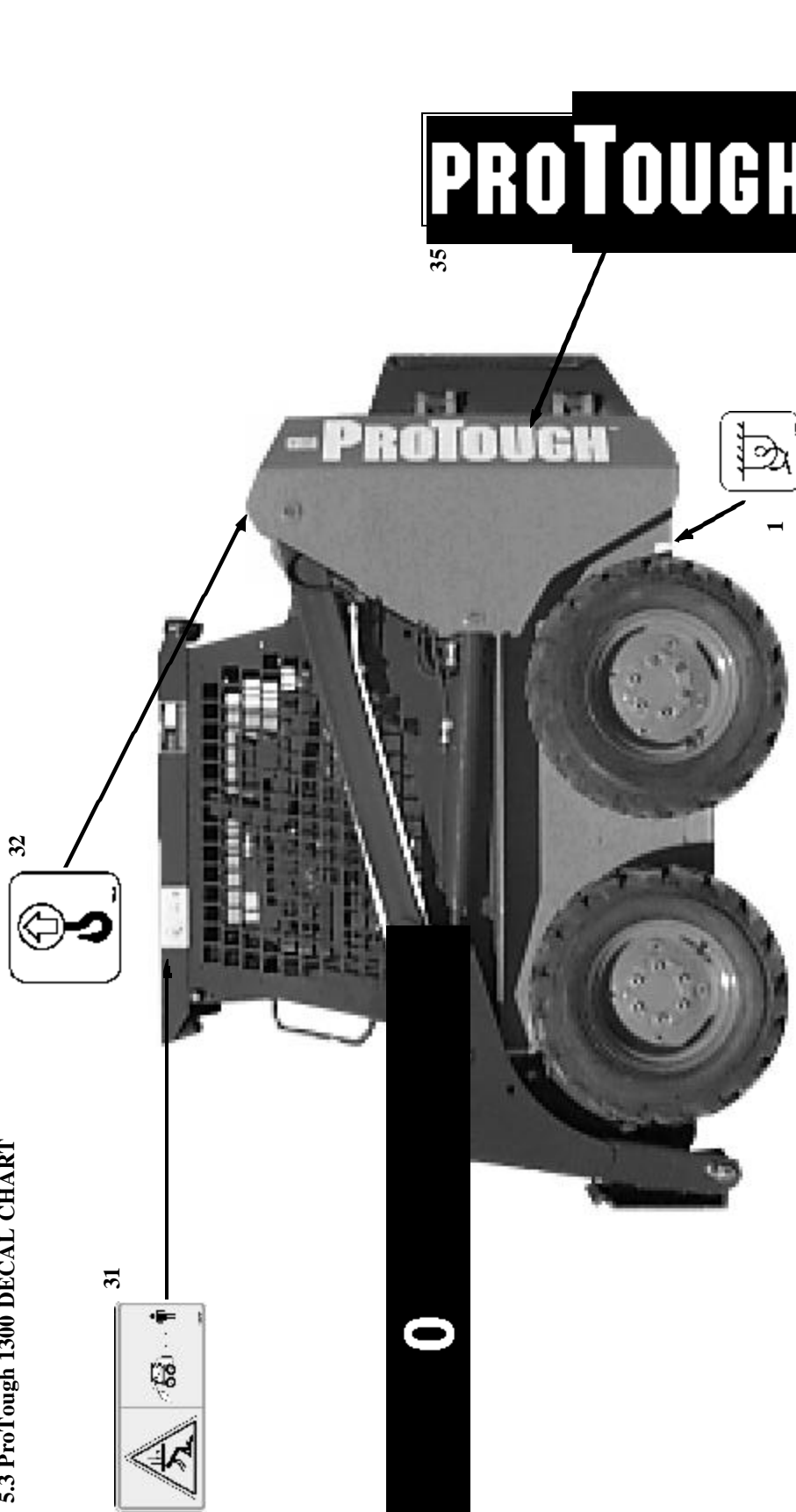

0

1. 39192 (4)	9. 37060	17. 36473	25. 23310	37010
2. 32275	10. 25460	18. 39191	26. 23325	23321
3. 41066	11. 37059	19. 36598	27. 39197	46375
4. 23324	12. N/A	20. 41064	28. 23308	
5. 39196	13. 31291	21. 23312	29. 23309	
6. 39191	14. 41045	22. 38043	30. 46376	
7. 33859	15. 23301	23. 23307	31. 41065	
8. 43264	16. N/A	24. 36841	32. 39191 (2)	



NOTES



8

THOMAS