

SECTION 2

HYDROSTATIC DRIVE SYSTEM

Hydrostatic Drive Circuit	2.1
Schematic	pg. 2-2
Specifications	2.2
Chart	pg. 2-3
General Information	2.3
Introduction	pg. 2-4
Trouble Shooting	2.4
Chart	pg. 2-5 ~ 7
Diagnose Steps	pg. 2-8
Pressure Tests	2.5
Procedure	pg. 2-9
Towing Procedure	2.6
Procedure	pg. 2-10
Flushing The Hydraulic System	2.7
General Information	pg. 2-11
Cleaning	pg. 2-12
Start-up Procedure	2.8
Procedure	pg. 2-14
Gear Pump Replacement	2.9
Procedure	pg. 2-15
Tandem Pump Replacement	2.10
Removal	pg. 2-16
Installation	pg. 2-17
Tandem Pump Parts Diagram	2.11
Parts Illustrations	pg. 2-20 ~ 23
Drive Motor	2.12
General Information	pg. 2-24
Removal	pg. 2-28
Replacement	pg. 2-30
Parts Illustration	pg. 2-32 ~ 33
Disassembly	pg. 2-34
Assembly	pg. 2-42



HYDROSTATIC CIRCUIT 2.1

2

Hydrostatic Circuit Schematic

C1007

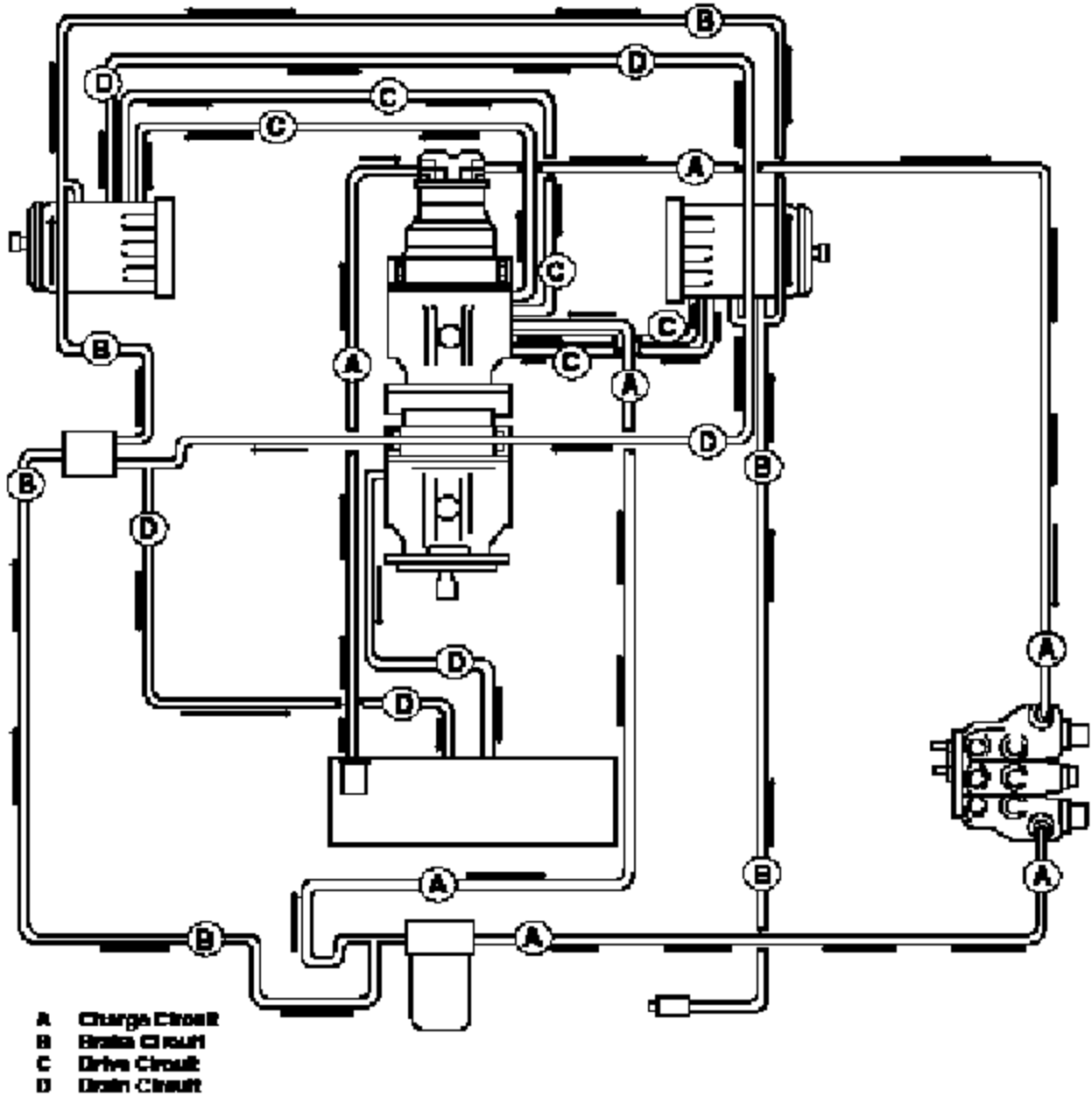

SPECIFICATIONS 2.2

Hydrostatic Tandem Pump

Pump Type	Variable Displacement, Reversible Piston
Brand Name of Pump	Sauer Sundstrand
Series / Model Type	40 / M25 PT
No. Of Drive Pumps	2 (TWO)
Mounting	Tandem
Rotation (viewed from shaft end)	Clockwise
Operating Speed	3000 RPM (+ / - 50 RPM)
Pump Displacement	1.5 cu. in. (25cc)
Minimum Pump Output (flow)	9.5 gal. (36L) / Minute @ 1800RPM
	@ 2000 PSI (137.8 Bar) Over Measured Charge Pressure
No. Of Relief Valves	2 (TWO)
Relief Valve Setting	250 Bar (3625 PSI)
Max. Allowable Case Pressure	25 PSI (1.7 Bar)
Charge Pump Type	N / A
Charge Pressure	200 PSI Min. (13.8 Bar)
Hydrostatic Repair Manual	Thomas P / N 44232
	Sauer Sundstrand P / N BLN-9992

Hydraulic Drive Motor

Drive Motor Type	Geroler Torque Motor With Brake
Brand Name	Danfoss
Series Type	OMT 315 FLV
Rotation	Dual
No. Of Drive Motors	2 (TWO)
Drive Motor Displacement	19.9 cu. in. (326.3cm ³)
Max. Case Pressure	25 PSI (1.7 Bar)

Reservoir

Fluid Type	10w30 API Class SE / CD Oil
Capacity	11.3 gal (43L)
Reservoir Filtration	One 100 Micron Screen Element
Hydraulic Oil Filtration	One 10 Micron Element
Hydraulic Element	P / N 35243



GENERAL INFORMATION 2.3

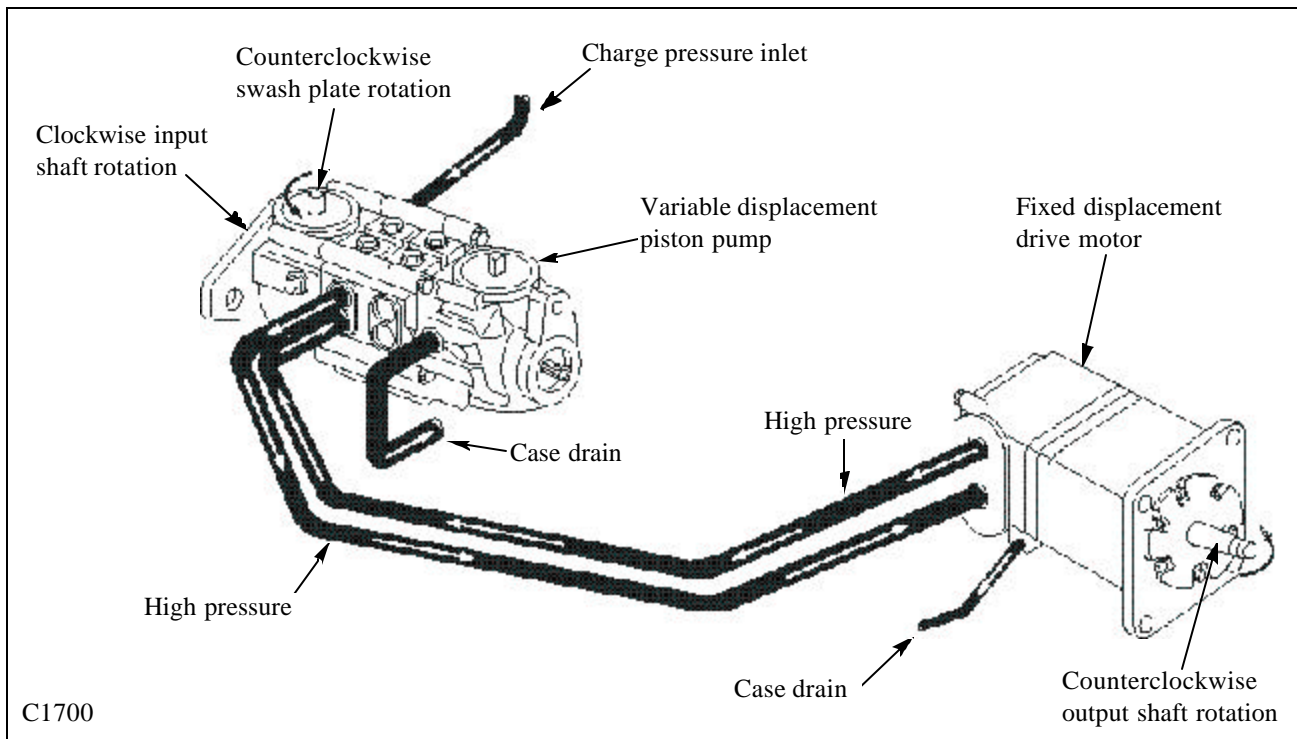

The driveshaft of the piston pump is rotated by the engine. The piston block which is splined to the driveshaft also turns. The piston block, rotating group, consists of 9 piston assemblies which have free swiveling shoes swagged on the ball end of each piston assembly. The shoe end of the piston rides against the smooth machined surface of the swashplate. With the swashplate in the neutral position, the piston assemblies do not reciprocate in the piston block, but are rotating. No oil is drawn into or discharged from the pump. The pump is in a zero displacement position and the loader remains stationary. With the swashplate in the neutral position the pressure of the charge oil, which ranges from 200 to 280 psi (13.8 - 19.3 Bar), is able to unseat both check valves and supply oil to both sides of the pump because of the balance in pressure. Very little charge oil volume is required in the neutral position so the excess oil is bypassed over the charge pressure relief valve and recirculated back to the reservoir. The oil that leaks internally in the pump and motor collects in their body housings and is returned to the reservoir by external case drain in the pump and motors. This leakage oil is the only oil the charge check replenishes. This makes the design a closed loop system. As the steering lever is moved forward, or reverse, the loader starts a directional movement. As the swashplate begins to move, the piston assemblies start to reciprocate in the piston block. As the steering lever continues further movement the cam angle increases, the pistons reciprocate further, more oil is pumped and the speed of the loader is increased.

When the swashplate begins to move the check valve on the discharge, or pressure, side seats because of the higher pressure differential. The other check valve remains open on the intake or low pressure side to continue supplying the closed loop system with charge oil.

The drive motor, which is a fixed displacement type, delivers a constant output torque for a given pressure throughout the speed range of the motor.

The movement of the pump swashplate, forward or reverse, controls the direction of the drive motor rotation. The function of the pressure relief valve is to relieve the pressure side of the system of excessive high pressure when the loader encounters a heavy load or stalls out. When the relief valve senses an over load it unseats, allowing excess pressure and volume to flow into the low pressure side of the pump. A small volume of oil starts to flow across to the other relief valve. This relief valve is exposed to the low pressure on the intake side of the pump and is seated by the spring tension within the relief valve body.

The small volume of oil being bypassed is enough to unseat the relief valve and let it recirculate back into the inlet side of the pump. As the pressure continues to build on the pressure side, a larger volume of oil flows and at a greater speed through the drilled orifice in the relief valve cartridge, causing a pressure drop inside the relief valve. The surrounding pressure is now able to unseat the relief valve and bypass maximum volume of oil. The system reliefs function the same for both sides of the system.

TROUBLE SHOOTING 2.4

Symptom: Operates In One Direction Only

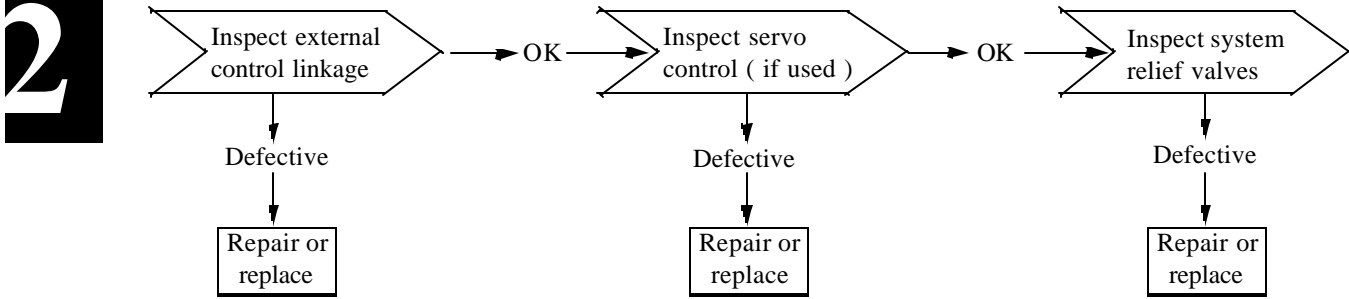

Symptom: System Response Sluggish

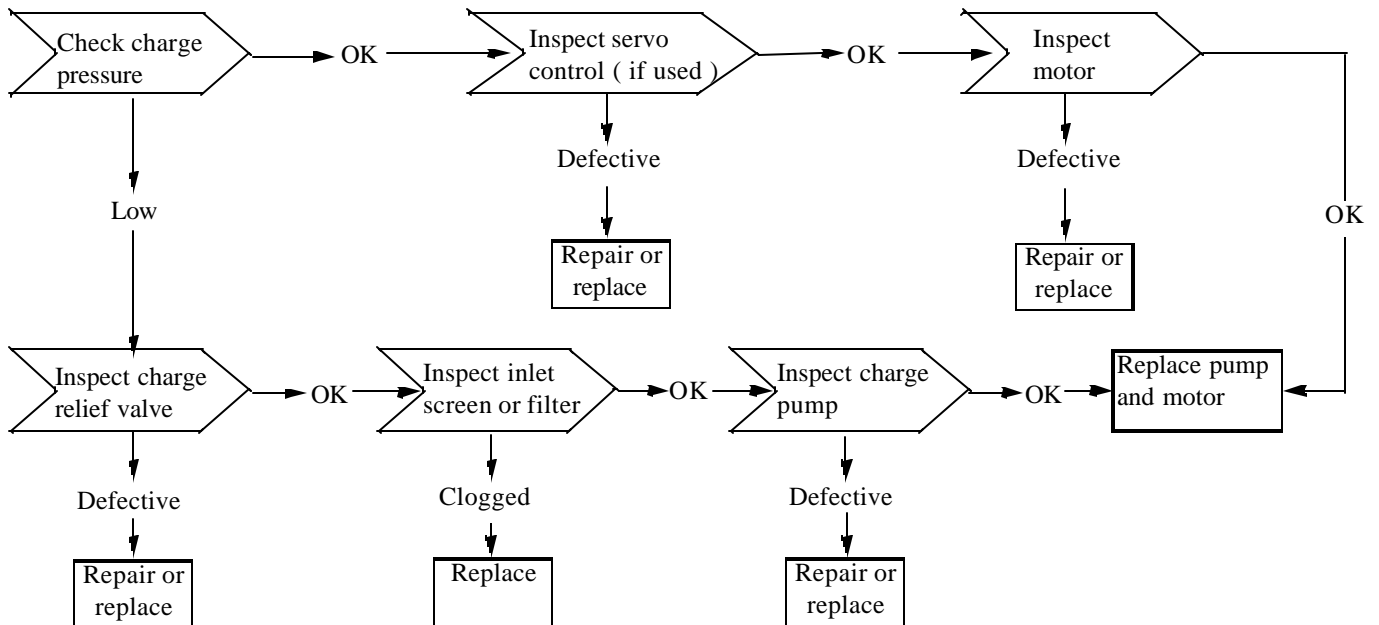

TROUBLE SHOOTING 2.4

Symptom: System Will Not Operate In Either Direction

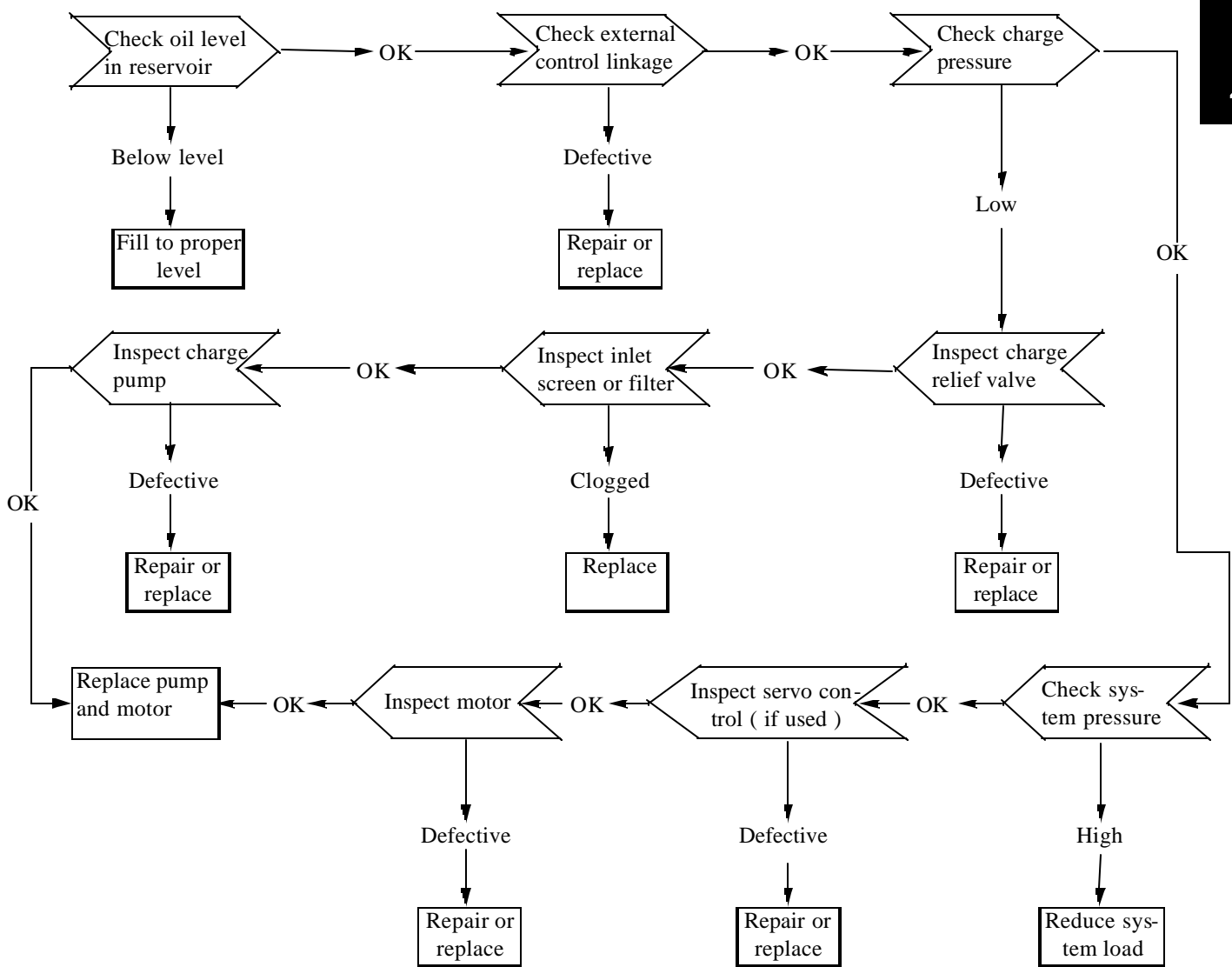

TROUBLE SHOOTING 2.4

System Diagnosing Steps And Special Tools

2

- 1 Check oil level in reservoir:**
 - a. fill to proper level as marked on site tube.
- 2 Inspect external control linkage for:**
 - a. misadjustment or disconnection
 - b. binding, bending or breakage
 - c. misadjusted, damaged or broken hydroback
- 3 Inspect servo control valve for: (if used)**
 - a. proper inlet pressure
 - b. misadjusted or damaged neutral return spring
 - c. galled or stuck control spool
 - d. galled or stuck servo piston
- 4 Inspect heat exchanger for:**
 - a. obstructed air flow
 - b. improper plumbing (inlet to outlet)
 - c. obstructed fluid flow
- 5 Inspect inlet filter or screen for:**
 - a. plugged or clogged screen or filter
 - b. obstructed inlet or outlet
 - c. open inlet to charge pump (open line)
- 6 Check charge pressure:**
 - a. follow test procedures section 2.5
- 7 Inspect charge relief valve for:**
 - a. poppet held of seat
 - b. damaged or broken spring
 - c. damaged valve seat
 - d. improper charge relief setting
- 8 Inspect charge pump for:**
 - a. broken or missing drive coupling
 - b. damaged or missing o-rings
 - c. galled or broken gerotor set
- 9 Inspect system relief valves for:**
 - a. damaged or broken springs
 - b. valve held of seat
 - c. damaged valve seat
 - d. improper pressure relief settings
- 10 Check system pressure:**
 - a. follow test procedures section 2.5
- 11 Inspect hydraulic motor for:**
 - a. disconnected coupling

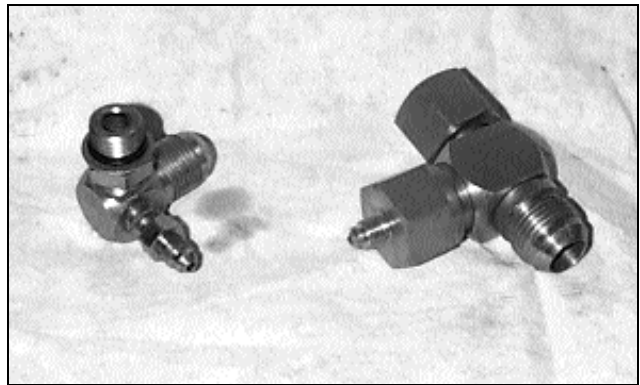
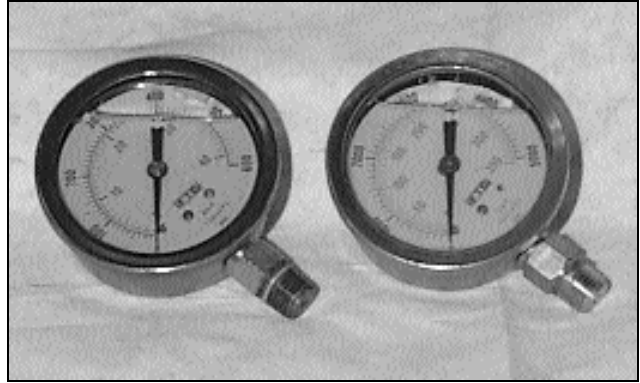

Caps and plugs

PRESSURE TESTS 2.5

The following photos show the various port locations available on the hydrostatic tandem pump for checking system pressure.
Completing these pressure test will diagnose any mechanical problem in the hydrostatic system.

WARNING

Use caution when dealing with hydraulic fluid under pressure. Escaping fluid under pressure can penetrate the skin and cause serious injury.

Installing a gauge into the high pressure port 'A' or 'B', will verify the status of the high pressure relief valves. Checking the pressure at port 'C' will give accurate charge pressure reading. Checking the pressure at port 'D' will verify case drain pressure. Measuring the vacuum at the charge pump inlet can help locate in in the inlet lines and filters. It would be necessary to tee into the charge pump line fitting. Snubbers are recommended to protect the gauges from pressure spikes. Frequent gauge calibration is necessary to insure accuracy.

Gauge Information		
A	System Pressure Port 'A'	10,000 PSI Gauge (690 Bar) 9/16 - 18 O-Ring Fitting
B	System Pressure Port 'B'	10,000 PSI Gauge (690 Bar) 9/16 - O-Ring Fitting
C	Charge Pressure Port	500 PSI Gauge (34.5 Bar) Tee Into Charge Filter Outlet Line
D	Case Pressure Port	500 PSI Gauge (34.5 Bar) 1 - 1/16 - 12 O-Ring Fitting
E	Charge Pump Inlet Vacuum	Vacuum Gauge (30 in. Hg) Tee Into Charge Pump Inlet

Tandem pump flow can also measure pump performance.

- 1 Connect a flow meter between the high pressure ports, one section at a time.
- 2 Start the engine and increase operating speed between 1775 ~ 1800 RPM.
- 3 Restrict the flow to show 2000 PSI (137.8 Bar) over charge inlet pressure.

Example: Charge pressure = 220 PSI (15.2 Bar) Gauge pressure reading would need to be 2220 PSI (153 Bar).

- 4 Minimum flow reading should be 9.5gal / min. (36L / min).

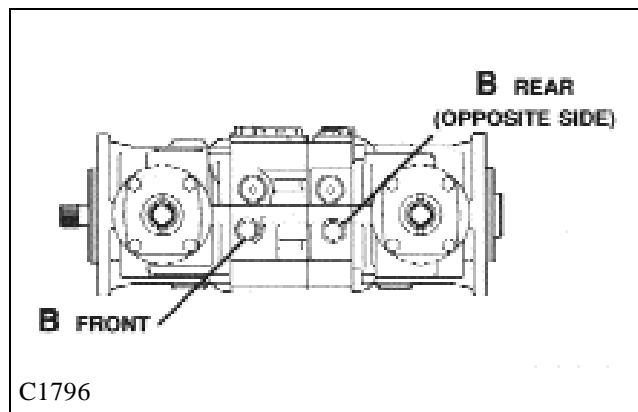
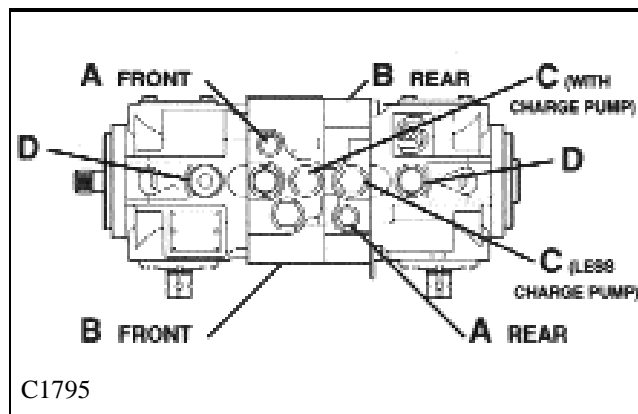
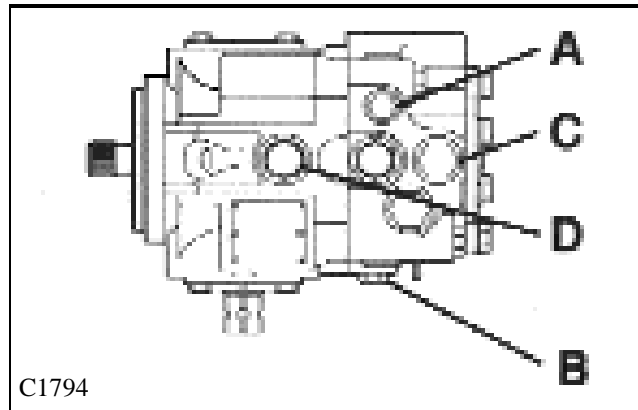

Illustrations are of an internal charge pump model. Actual model in machine may vary.

WARNING

Raise the machine securely from the ground before performing system checks to prevent sudden movement.

A complete testing kit is available from Thomas, p/n 44365, that contains gauges, hoses and adapters for Sauer Sundstrand model pumps.

TOWING 2.6

In an event the loader has malfunctioned or failed, the loader may be moved a short distance by following the procedure:

2

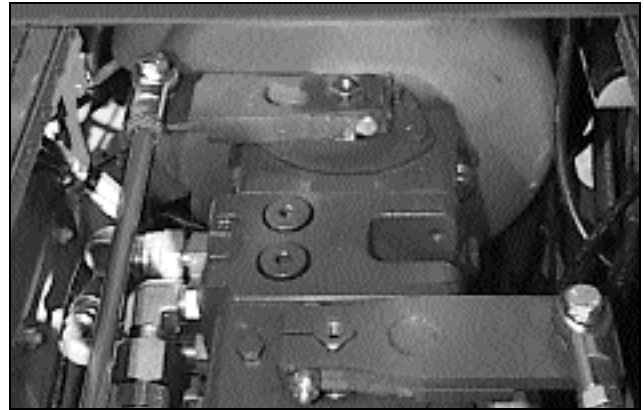

Brake release plunger

Brake valve

C2362

FLUSHING THE HYDRAULIC SYSTEM 2.7

General Information

Contamination in the hydraulic system is a major cause of component failure. Contamination can enter the hydraulic system in any of the following ways.

- 1 When draining the hydraulic system.
- 2 When disassembling components.
- 3 Making auxiliary connections with dirty couplers.
- 4 Normal component wear.
- 5 Component failure

The best way to remove contaminants from the hydrostatic drive system is to disassemble each component and flush and clean thoroughly.

The hydraulic control circuits may be cleaned by attaching a suitable hydraulic filter to the auxiliary couplings and circulating the fluid through it.



Contamination Types

There are 2 types of contamination, microscopic, or non visible, and visible. Microscopic contamination is suspended in the fluid and moves freely through the hydraulic circuits. Examples of problems caused by microscopic contaminants include the following:

- 1 Cylinder rod seal leaks.
- 2 Control valve spools do not return to neutral.
- 3 Hydraulic system has a high operating temperature.
- 4 Components wear rapidly.

Visible contamination is foreign material that can be found by sight, touch or odor. Some examples of visible contamination include the following:

- 1 Particles of metal or dirt in the oil.
- 2 Air in the oil.
- 3 Odor of burned oil.
- 4 Water in the oil.

FLUSHING THE HYDRAULIC SYSTEM 2.7

Cleaning The System

The first step in cleaning the hydraulic system is to determine if you have visible or microscopic contamination. If the contamination is visible, do the following steps:

1 Change the hydraulic oil by removing the drain plug in the bottom of the hydraulic oil reservoir. (fig. C1034) Be prepared to contain approximately 30 litres of fluid.

2 Check the extent of the contamination by disassembling 1 each of the hydraulic cylinders. Check the cylinders for damage. Repair or replace the cylinders as required. If you determine the damage was caused by severe contamination and is not the result of normal wear, it will be necessary to remove, clean and repair all valves, pumps, lines, cylinders, etc.

3 Replace all hydraulic filters.

If the contamination is determined to be microscopic, perform the following steps:

1 Change the hydraulic oil by removing the plug in the bottom of the oil reservoir. (fig. C1034) Be prepared to contain approximately 30 litres of fluid.

2 Connect an external 10 micron filtering system, capable of sustaining minimum of 2000 PSI (138 Bar) and has a back pressure gauge, to the auxiliary couplings. (fig. C2351, C1688)

3 Start the engine and let it idle at approximately half throttle.

WARNING

Be sure to use a filtering system capable of handling the pressure of the hydraulic system.

4 Engage the auxiliary circuit. Check to make sure the filtering system is not over taxed by the loaders hydraulic system pressure. Adjust engine idle accordingly to match the filtering systems capacity. This may vary as the filter becomes dirty, you may need to decrease engine RPM. Circulate the oil through filter for 30 minutes.

5 As the oil is being circulated through the auxiliary circuit, raise the liftarms up and down in full stroke cycles. Repeat this exercise for 15 minutes.

6 Cycle the bucket tilt cylinders in the same manner as above. Repeat the exercise, in full extension and retraction, for 15 minutes.

7 Install new hydraulic oil filters. (fig. C2354a)

8 Start the engine and check for leaks. Replenish the hydraulic oil reservoir as required. (fig. C2354b)

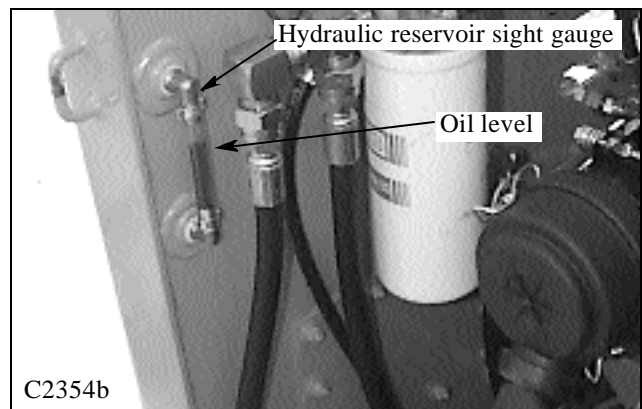
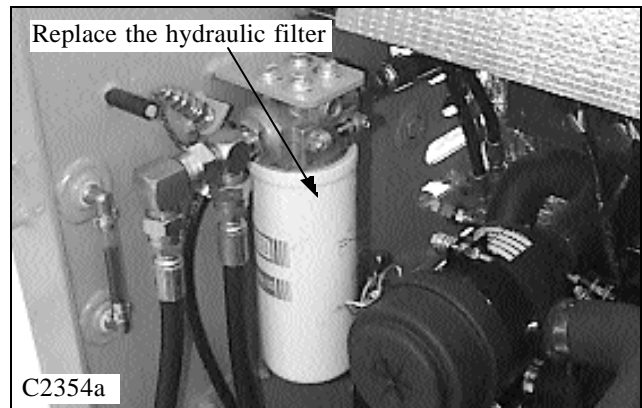
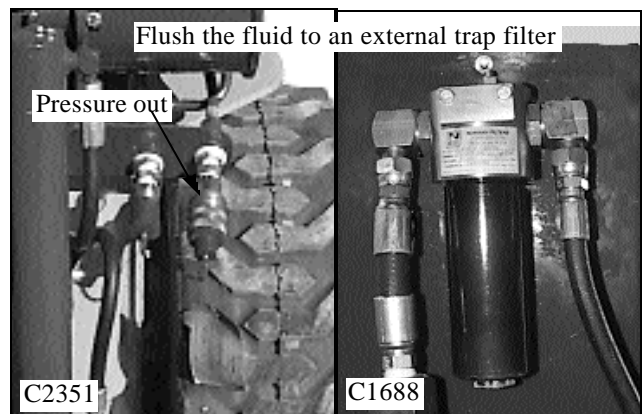
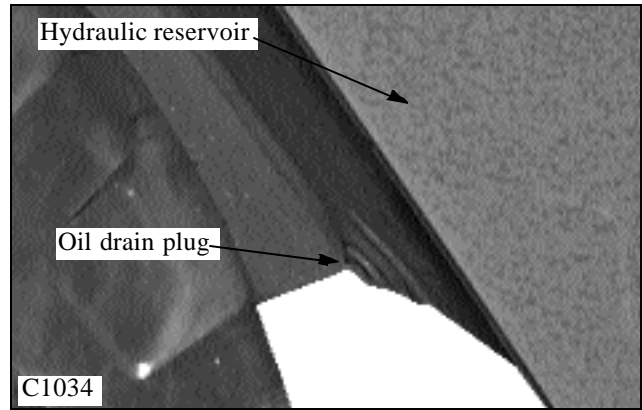

2

FLUSHING THE HYDRAULIC SYSTEM 2.7

For flushing water from the hydraulic system, perform the following procedures:

WARNING

Be sure attachments are removed and liftarms are in the lowered position.

- 1 Remove any attachment.
- 2 Make sure all cylinders are fully retracted.
- 3 Change the hydraulic fluid. (fig. C1034)
- 4 Change the hydraulic filter. (fig. C2354)
- 5 Disconnect the hydraulic lines from one set of cylinders. (fig. C2356, C1336)
- 6 Start the engine and set to the lowest idle.
- 7 Have someone hold the open hydraulic lines into a container. Stroke the foot pedals, or hand operated, controls slowly. Continue to repeat this cycle until the oil comes out clear. Repeat for opposite set of cylinders.

WARNING

Use caution when dealing with hydraulic fluid under pressure. Escaping fluid under pressure can penetrate the skin and cause serious injury.

- 8 Attach a hose and couplings to the auxiliary circuit. Engage the auxiliary hydraulics, forward and reverse, until the oil flows clear.

IMPORTANT

Check the hydraulic oil frequently during this procedure. Replenish as required.

- 9 Connect 1 hose each, on each cylinder, to the fixed end of the cylinder barrel.
- 10 Move the foot pedal or control lever to extend the cylinder rods. This will flush the oil from inside the cylinder barrels. Be prepared to contain the waste oil.
- 11 Stop the engine.
- 12 Connect the hydraulic hoses to the rod end of the cylinder barrel.
- 13 Replenish the hydraulic oil as required.
- 14 Replace the hydraulic filter.

IMPORTANT

Please contain and dispose of waste oil in an environmentally friendly manner.

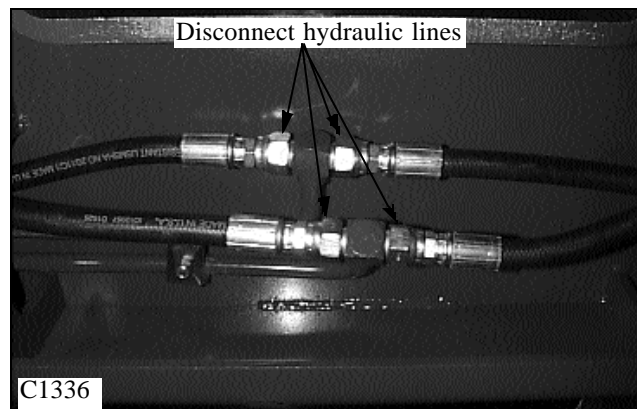
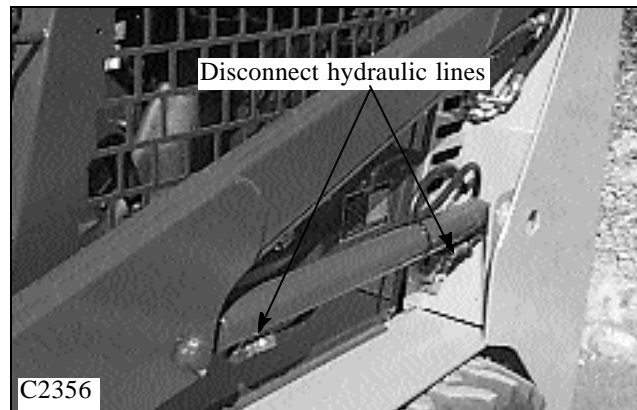
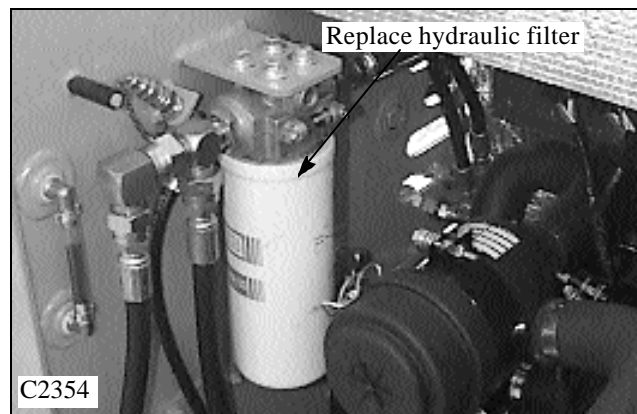
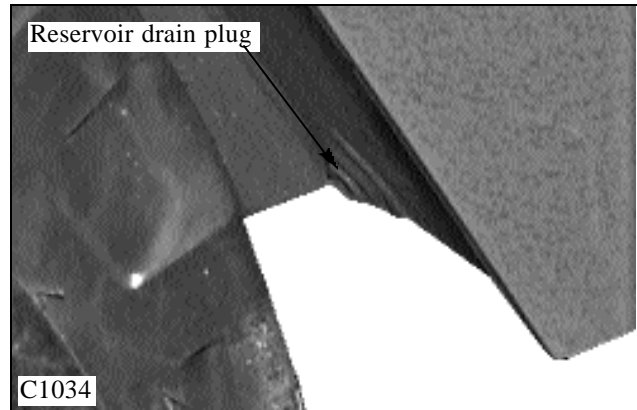

START-UP PROCEDURE 2.8

The following start-up procedure should always be adhered to when starting up a new installation or when restarting after pump repairs have been made.

1 Fill the hydraulic oil reservoir to the proper level. (fig. C2354)

2

2 The inlet hose from the oil reservoir to the charge should be filled with oil prior to starting.

3 Check inlet and pressure hose fittings for proper tightness prior to starting.

4 The pump must be filled prior to start-up with filtered oil. Fill the pump by pouring oil into the side case drain port. (fig. C1795 location "D")

5 Disconnect the engine stop solenoid wiring connector. (fig. C2607)

6 Turn the engine over by engaging the starter. Repeat this step, turning the engine over in 15 second interval, 5 or 6 times. This will fill the rest of the hydraulic hoses.

7 Reconnect the engine stop solenoid.

8 Start the engine and let it idle at lowest possible setting.

9 Check for leaks and make adjustments as required. Do not use your hands to check for leaks while the engine is operating.

10 Replenish the hydraulic oil reservoir as required.

11 Start the engine and increase the RPM's to half throttle. Bring the hydraulic fluid up to operating temperature and make control adjustments as outline in Section 4.

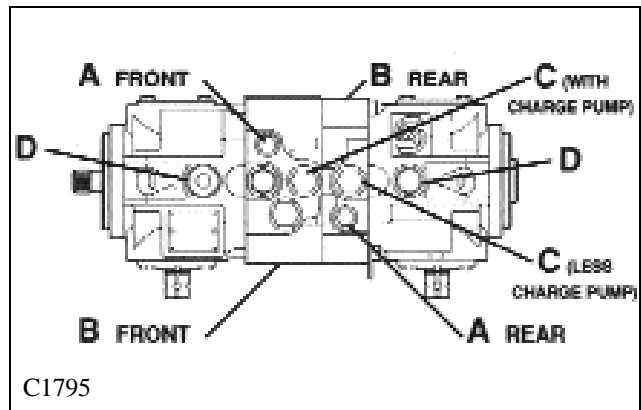
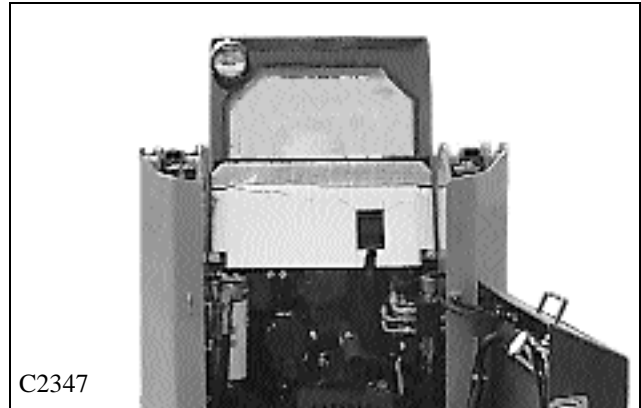

Solenoid wire connector

C2607

GEAR PUMP REPLACEMENT 2.9

Start the gear pump removal procedure by removing any attachment, raising the boom arms and engaging the boom support pins. Shut off the engine.

1 Remove the seat and hydrostatic shield.

2 Attach a vacuum system to the hydraulic oil reservoir filler location. (fig. C1689) Or drain the oil reservoir. Seal the threads on the drain plug, if removed, with teflon tape or a liquid form of pipe sealant before installing.

3 Disconnect the hydraulic hoses from the gear pump. (fig. C2353a) Remove the pump fittings. Cap all open hoses to prevent contamination. After capping ends you may unhook vacuum system from oil reservoir.

4 Remove the 2 bolts holding the gear pump to the hydrostatic tandem section. (fig. C2353b) Remove the gear pump.

5 Replace gear pump in reverse order.

6 If the hydraulic system has been contaminated by pump or other failure you must follow the cleaning procedure outlined in section 2.7.

7 Start the engine and check for leaks. Never use your hands to find leaks.

8 Check the fluid level in the hydraulic oil reservoir and replenish as required. (fig. C2354).

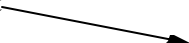
Reservoir filler spout 

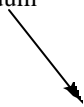
Vacuum 

C1689



TANDEM PUMP REPLACEMENT 2.10

Removal

Begin the pump removal by removing any attachment, raise the boom arms and engage the boom support pins. Shut off the engine.

1 Remove the seat and hydrostatic shield.

2 Remove the steering lever linkage. Refer to section 4 for removal and replacement information.

3 Remove the gear pump as outlined in section 2.9.

4 Disconnect all the hydraulic hoses. (fig. C2359, C2610) Marking the hose and fitting location is recommended to ease re-assembly. Upon re-assembly, torque the hydraulic fittings and hoses as outlined in the Torque Chart in Section 8. Cap all open lines and ports.

5 Remove the hydraulic fittings from the tandem pump to prevent damage while removing pump. Plug all open ports and keep the fittings in a clean area. Inspect fittings and o-rings for damage, replace as required.

6 Loosen the mounting bolts retaining the tandem pump to the engine bellhousing. (fig. C2608, C2609).

7 Attach a lifting device to the tandem pump. The pump is fairly heavy, approximately 80 lbs. (36 Kg) It is highly recommended to use a mechanical lifting device to assist removal of the tandem pump.

8 Remove the 2 rear mounting bolts. (fig. C2608, C2609) Remove the tandem pump from the loader.

Refer to the Sauer Sundstrand Repair Manual, (Thomas p / n 44232 or Sauer Sundstrand p /n BLN - 9992), for complete pump servicing.

Thomas does not cover or handle warranty processing or repair work performed on the Sauer Sundstrand product. Warranty work can only be approved and performed by an authorized Sauer Sundstrand dealer.

High pressure hoses



Tandem case drain hose



C2359

2

TANDEM PUMP REPLACEMENT 2.10

Installation

Upon reassembly, inspect the outside area of the tandem pump housing for damage that may have occurred in transit or handling.

- 1 Attach a lifting device to the tandem pump.
- 2 Apply lithium type grease to the tandem pump input shaft and the flywheel coupling splines. (fig. C2616).

CAUTION

To prevent personal injury, do not attempt to lift heavy objects without assistance.

- 3 Install the tandem pump to the engine bellhousing lining up the input shaft splines with the flywheel coupler. (fig. C2617)
- 4 Install the 2 mounting bolts. Torque the 2 mounting bolts to 60 ft/lbs. (82 nm.) Remove the lifting device.

5 Connecting the 4 high pressure drive hoses and fittings to the tandem pump can only be accomplished in a specific sequence. (fig. C2610). Install the bottom 90° connector to the tandem pump first, then the bottom straight connector.

- A Hose no. 1 connects to the top port of the left hand drive motor.
- B Hose no. 2 connects to the bottom port of the left hand drive motor.
- C* Hose no. 3 is the charge pressure line, connect to the hose from the hydraulic filter. This fitting must be installed before connecting hose no. 4 and 5. See fig. C2611 next page.
- D Hose no. 4 connects to the bottom port of the right hand drive motor.
- E Hose no. 5 connects to the top port of the right hand drive motor.

Torque the fittings and hoses according to the Torque Chart in Section 8.

IMPORTANT

When making repairs to the hydraulic system, keep the work area and parts clean. Use caps and plugs on all open line and ports.

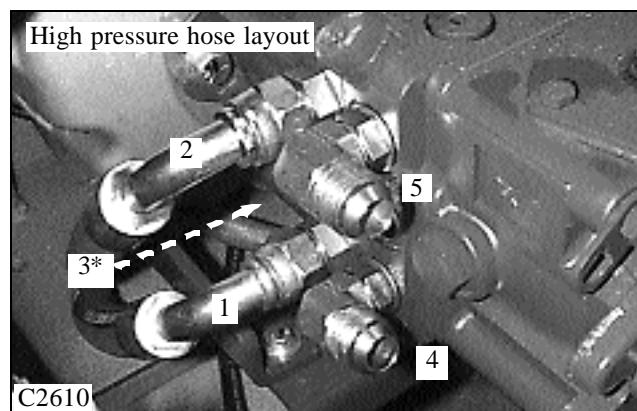
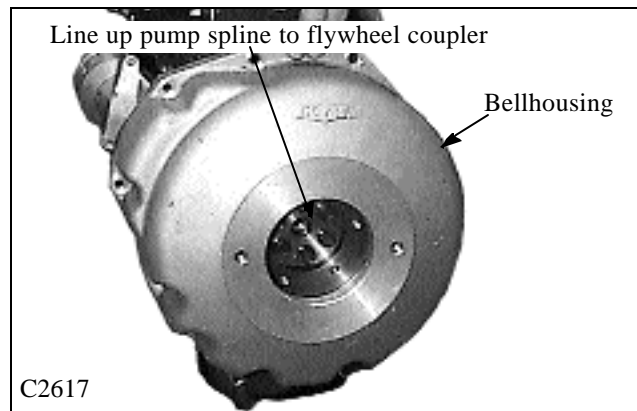
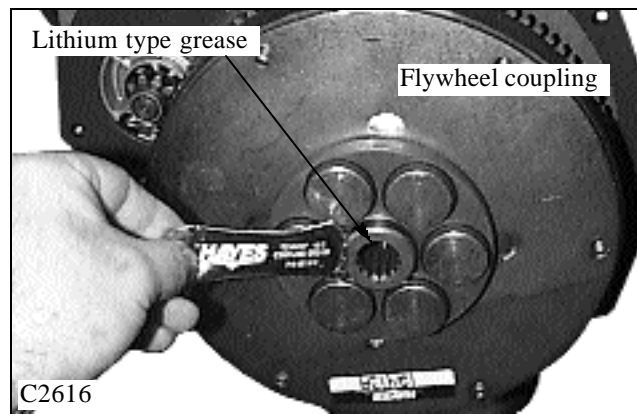
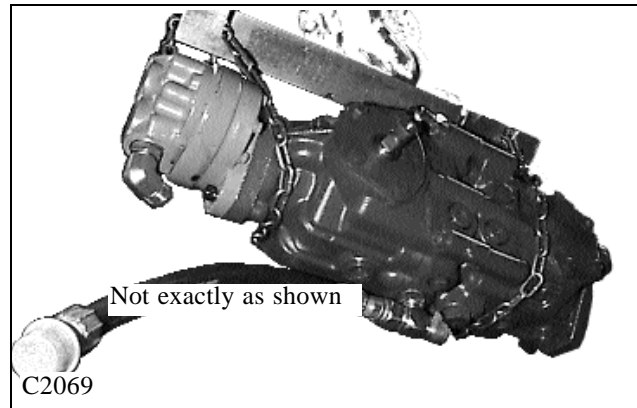

2

TANDEM PUMP REPLACEMENT 2.10

Installation (continued)

6 Connect the tandem pump case drain fitting and hose. (fig. C2608) Torque the fittings and hose to the specifications listed in the Torque Chart in Section 8.

IMPORTANT

When making repairs to the hydraulic system, keep the work area and parts clean. Use caps and plugs on all open line and ports.

7 Connect the auxiliary gear pump outlet fittings and hoses to the gear pump. (fig. C2353) Follow the Torque Chart in Section 8 when tightening fittings and hoses.

IMPORTANT

Inspect hydraulic fitting o-rings and flares for marks or damage. Replace if necessary.

8 Remove the plug on the side of the tandem pump and fill the tandem pump with filtered. (fig. C2608)

IMPORTANT

Follow the Torque Chart In Section 8 when tightening fittings and hoses.

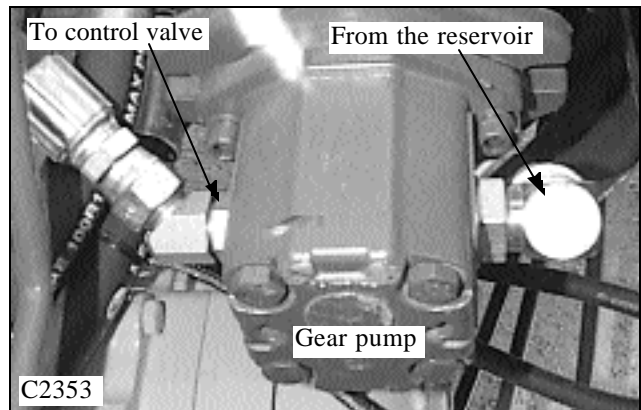
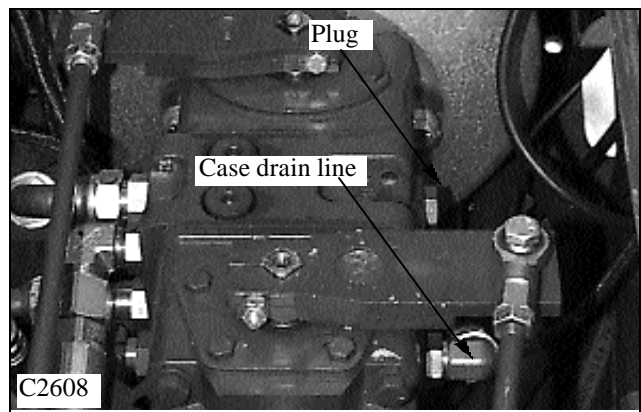
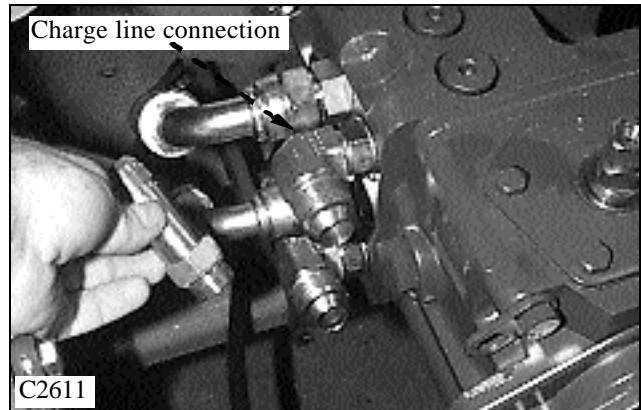

TANDEM PUMP REPLACEMENT 2.10

Installation (continued)

9 Reinstall the steering control linkages as outlined in Section 4. (fig. C2443).

10 Fill the hydraulic oil reservoir to the proper level.

11 Follow the start up procedure outlined in section 2.8 before attempting to start the loader.

IMPORTANT

Follow the start up procedure outlined in section 2.8 upon restarting after pump repairs or replacement.

WARNING

This start-up procedure must be made with the loader securely raised off the ground. Changing the pumps and the steering control linkages has affected the neutral adjustment. Failure to raise the loader clear of the ground may result in the loader engaging in motion and possibly causing serious injury.

12 Start the loader and check for leaks. Make repairs as necessary and replenish the hydraulic oil reservoir. Never use your hands to check for hydraulic leaks.

WARNING

To prevent personal injury never make repairs to the hydraulic system while the engine is operating. Use caution when dealing with hydraulic fluid under pressure. Escaping fluid under pressure can penetrate the skin and cause serious injury.

13 Make adjustments to the steering controls as required. Follow the procedures for control adjustments in Section 4.

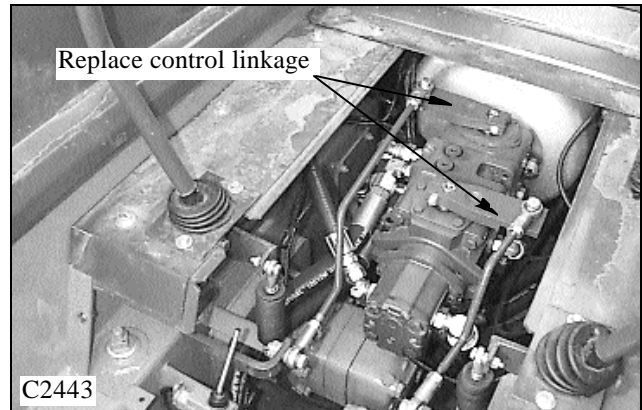

C2443

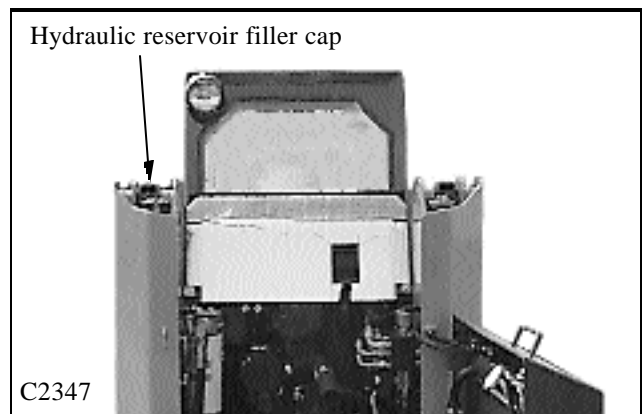

C2347

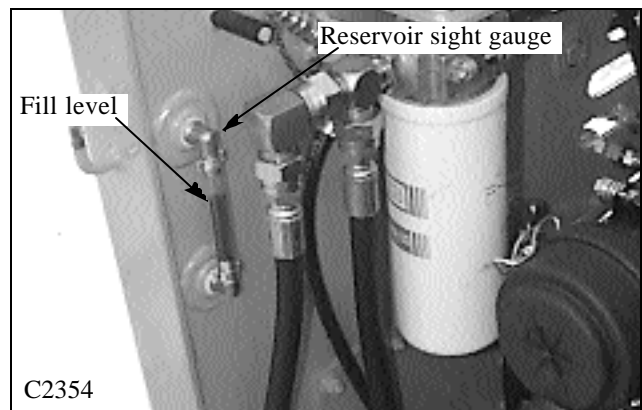

C2354

2

TANDEM PUMP PARTS DIAGRAM 2.11

2

Sauer Sundstrand Series M25 PT Rear Pump (as located in machine)

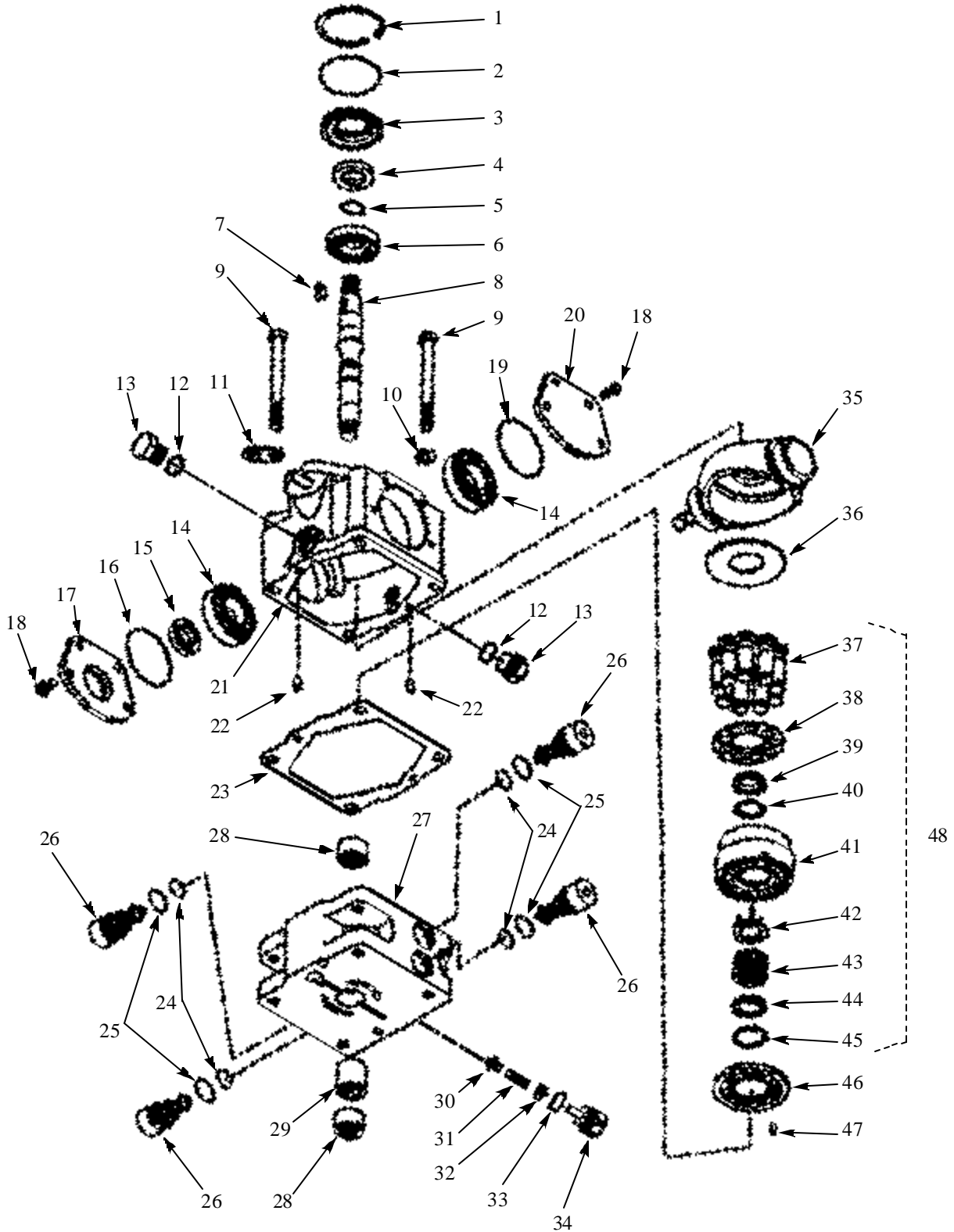

C2621

TANDEM PUMP PARTS DIAGRAM 2.11

Rear Pump Diagram C2621 Index

- | | |
|----------------------------|---------------------------------------|
| 1. Retaining ring | 25. O-ring seal |
| 2. O-ring seal | 26. Relief valve, items 24 ~ 26 |
| 3. Seal carrier | 27. Center section |
| 4. Input seal | 28. Bearing |
| 5. Retaining ring | 29. Coupler |
| 6. Bearing | 30. Charge relief poppet |
| 7. Key (or splined shaft) | 31. Charge relief spring |
| 8. Drive shaft | 32. Charge relief shims |
| 9. Bolt | 33. O-ring seal |
| 10. Washer | 34. Charge relief, items 30 ~ 33 |
| 11. Lifting bracket | 35. Swashplate |
| 12. O-ring seal | 36. Thrust plate |
| 13. Plug, includes item 12 | 37. Piston assembly |
| 14. Bearing | 38. Slipper retainer |
| 15. Seal | 39. Slipper retainer guide |
| 16. O-ring seal | 40. Thrust washer |
| 17. Trunnion cover | 41. Cylinder block |
| 18. Bolt | 42. Washer assembly |
| 19. O-ring seal | 43. Spring |
| 20. Trunnion cover | 44. Special washer |
| 21. Housing | 45. Retaining ring |
| 22. Dowel pin | 46. Valve plate, clockwise |
| 23. Gasket | 47. Spring pin |
| 24. O-ring seal | 48. Cylinder block kit, items 37 ~ 45 |

For further service instructions refer to a Sauer Sundstrand Dealer and request Service / Repair Manual Part Number BLN 9992 or order P / N 44232 from a local Thomas Dealer.



TANDEM PUMP PARTS DIAGRAM 2.11

2

Sauer Sundstrand Series M25 PT Front Pump (as located in machine)

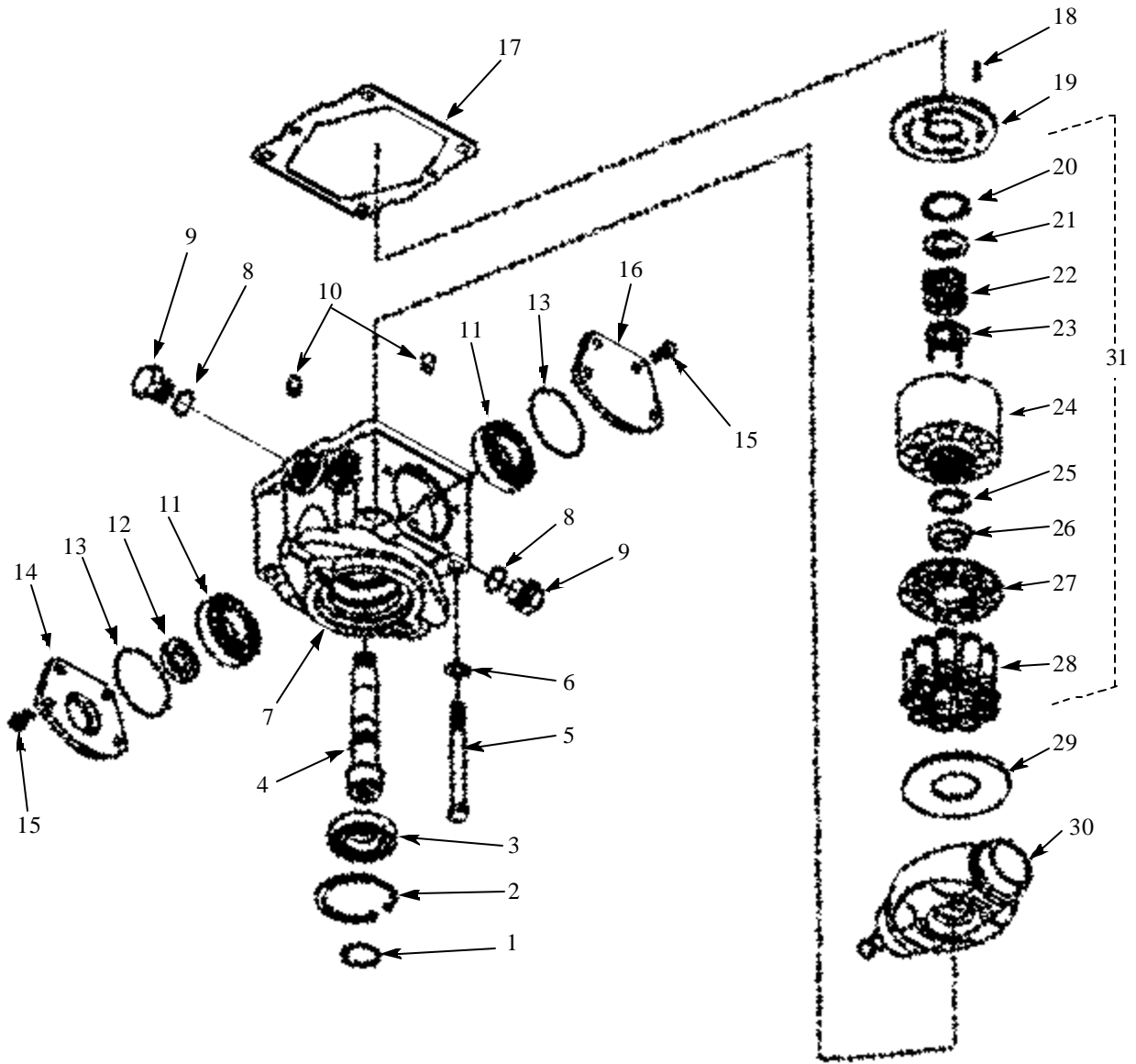

C2622

TANDEM PUMP PARTS DIAGRAM 2.11

Front Pump Diagram C2622 Index

- | | |
|--------------------------|---------------------------------------|
| 1. Retaining ring | 17. Gasket |
| 2. Retaining ring | 18. Pin |
| 3. Bearing | 19. Valve plate, counter clockwise |
| 4. Drive shaft | 20. Retaining ring |
| 5. Bolt | 21. Special washer |
| 6. Washer | 22. Spring |
| 7. Housing | 23. Washer assembly |
| 8. O-ring seal | 24. Cylinder block |
| 9. Plug, includes item 8 | 25. Thrust washer |
| 10. Dowel pin | 26. Slipper retainer guide |
| 11. Bearing | 27. Slipper retainer |
| 12. Seal | 28. Piston assembly |
| 13. O-ring seal | 29. Thrust plate |
| 14. Trunnion cover | 30. Swash plate |
| 15. Bolt | 31. Cylinder block kit, items 20 ~ 28 |
| 16. Trunnion cover | |



For further service instructions refer to a Sauer Sundstrand Dealer and request Service / Repair Manual Part Number BLN 9992 or order P / N 44232 from a local Thomas Dealer.

DRIVE MOTOR 2.12

General Information

2

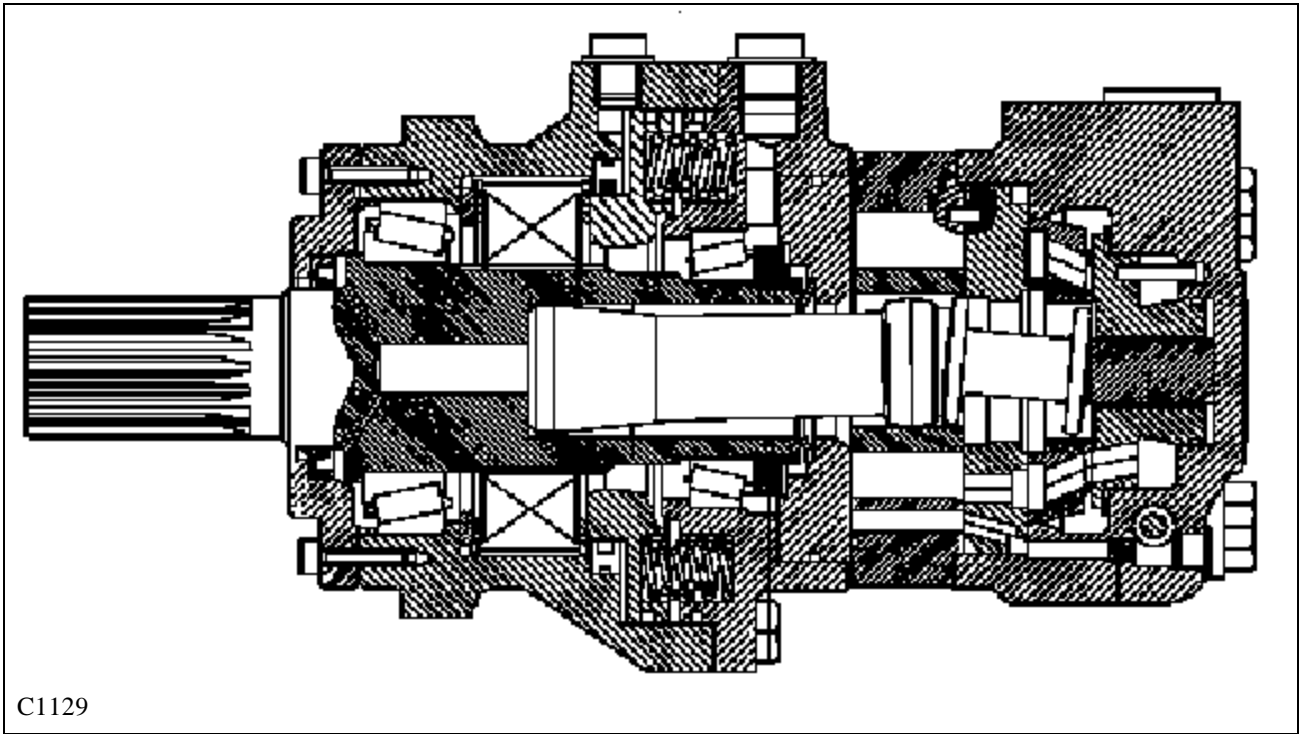

The basic gerotor design uses a combination of mechanical and hydraulic principles that are utilized in the high torque, low speed motors.

The outer ring (fig. C153) of the gerotor assembly is similar to an internal gear that is held in a fixed position by securing it to the motor housing. The rotating inner gear, called a star, orbits inside the secured outer ring.

Because of the different number of teeth on the star and outer ring, the star rotates in an eccentric circular orbiting motion from the housing center line. (fig. C154).

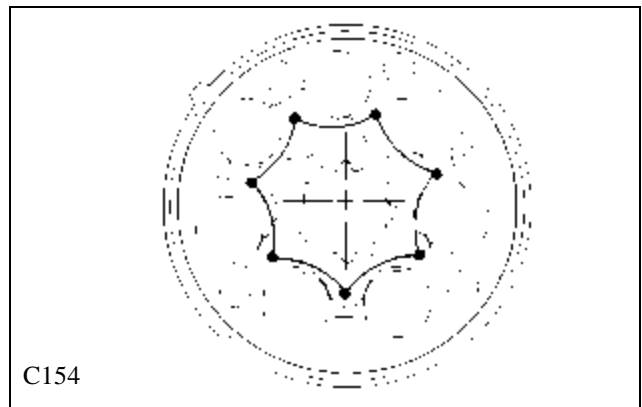
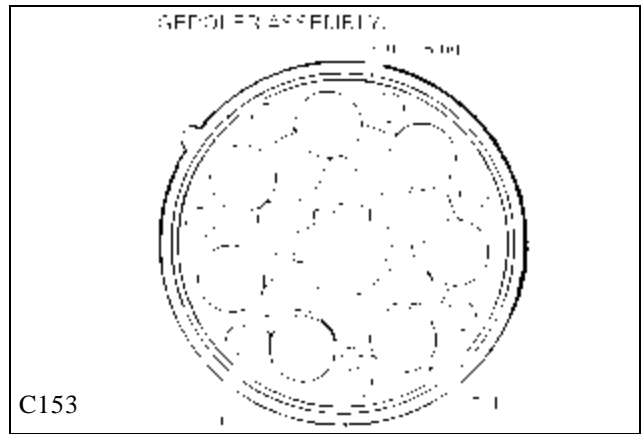

DRIVE MOTOR 2.12

A drive shaft is used to transmit the rotation of the star to the output shaft. The drive shaft has crowned external splines to match the internal splines in the star and output shaft. This type of drive is used because the star center line continuously changes during rotation.

As the star orbits, it causes a continuous opening and closing of the outer ring fluid pockets. Half of these fluid pockets are subject to fluid pressure, causing star rotation, and the opposing half are connected to the return line.

When pressure is introduced into the fluid pockets on the right side of the star (fig. C156) the output rotation will be counterclockwise. When the fluid pockets on the left side of the star are pressurized the output shaft rotation will be clockwise.

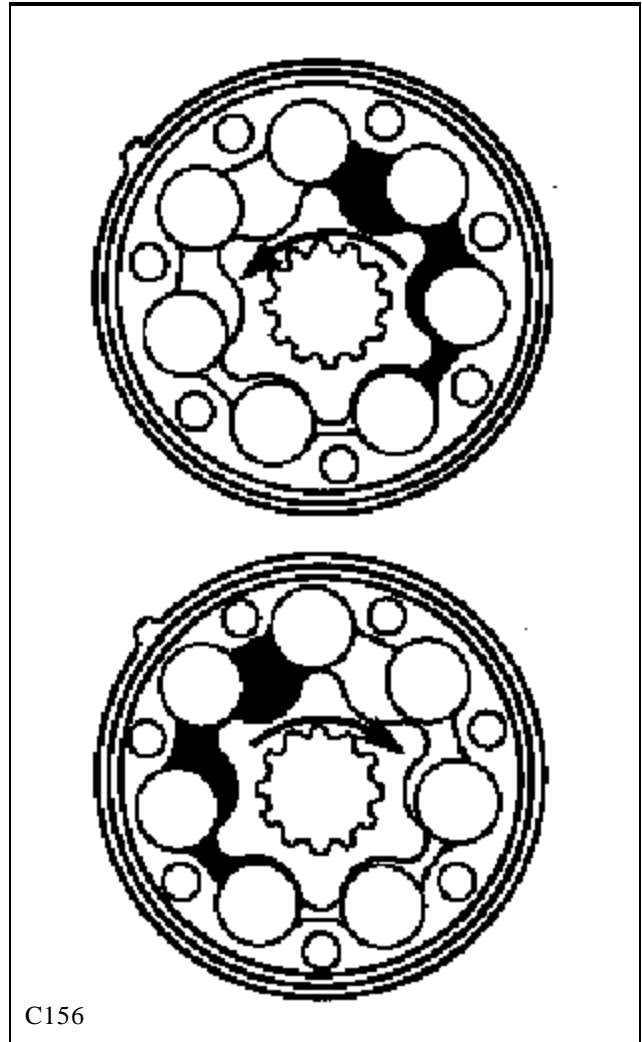

To seal the fluid pockets the torque motor incorporates a rotating roller type seal. (fig. C157) This type of a rolling seal reduces friction at the star points providing increased efficiency and reduced component wear.

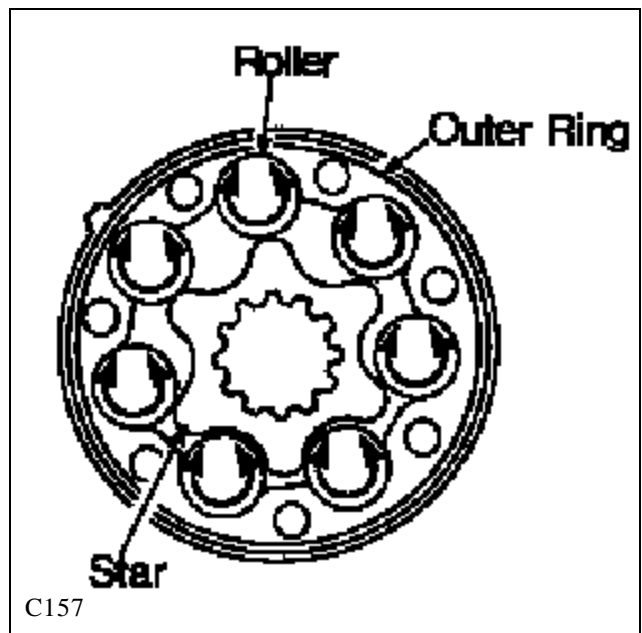

DRIVE MOTOR 2.12

2

The geroler (fig. C2299), is both a fluid displacement motor and a gear reducer. It provides 8 times (the number of star points) greater power per revolution than a gear, vane or piston type motor. This means that 8 times the greater torque can be developed at one eighth the speed without further gear reduction.

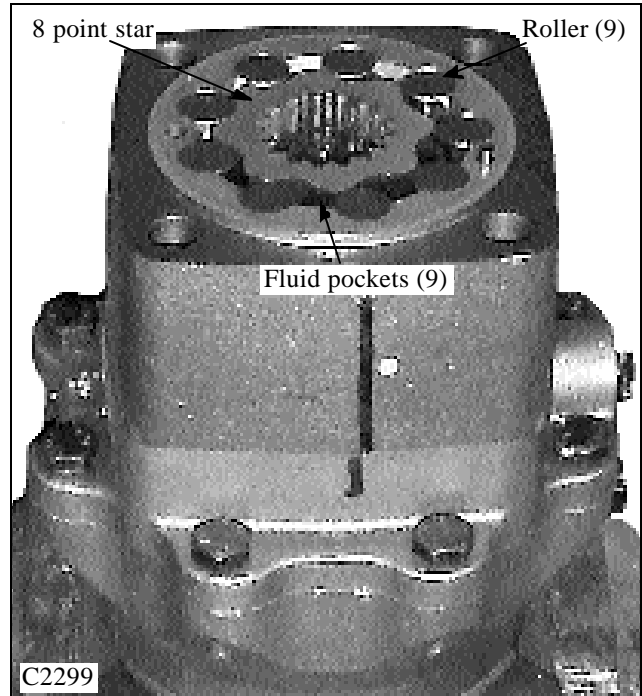

Example shown in fig. C166 is one complete star orbit, or one sixth of the output shaft rotation. The star must travel through 6 complete orbits for each single rotation of the output shaft creating a speed reduction of 6 to 1. The use of 7 fluid power pockets with the 6 to 1 ratio provides 42 fluid power cycles per each complete shaft revolution. **NOTE: Actual star point count is 8. This is only an example.**

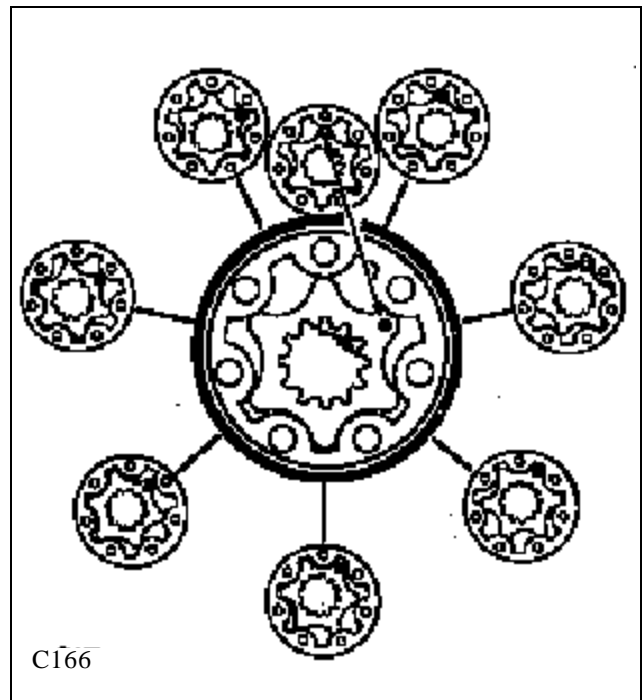

DRIVE MOTOR 2.12

For smooth and continuous motor output rotation, the torque motor utilizes a disc valve which operates in synchronization with the geroler star. The disc valve arrangement consist of a stationary balance plate, rotating disc valve and a stationary valve plate.

The disc valve contains an inlet fluid passage port for each star valley and a return fluid passage point.

A separate crowned driveshaft is used to synchronize the disc valve and the geroler star so that they turn as one. To accept fluid from the disc valve, the valve plate also contains internal porting passages to each outer ring pocket area.

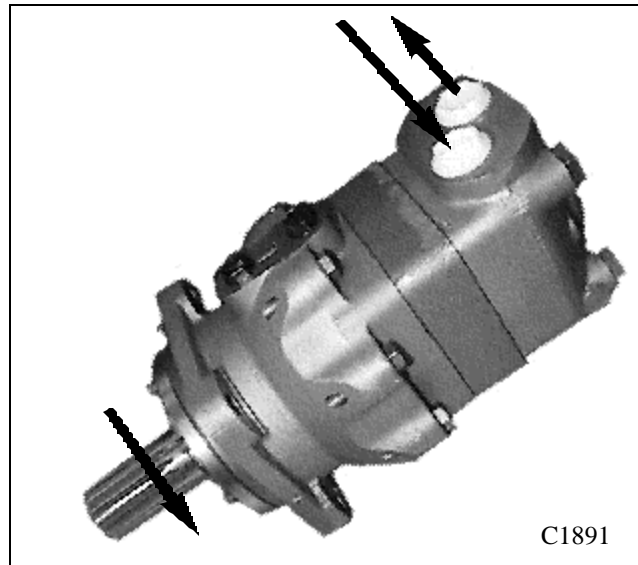

2

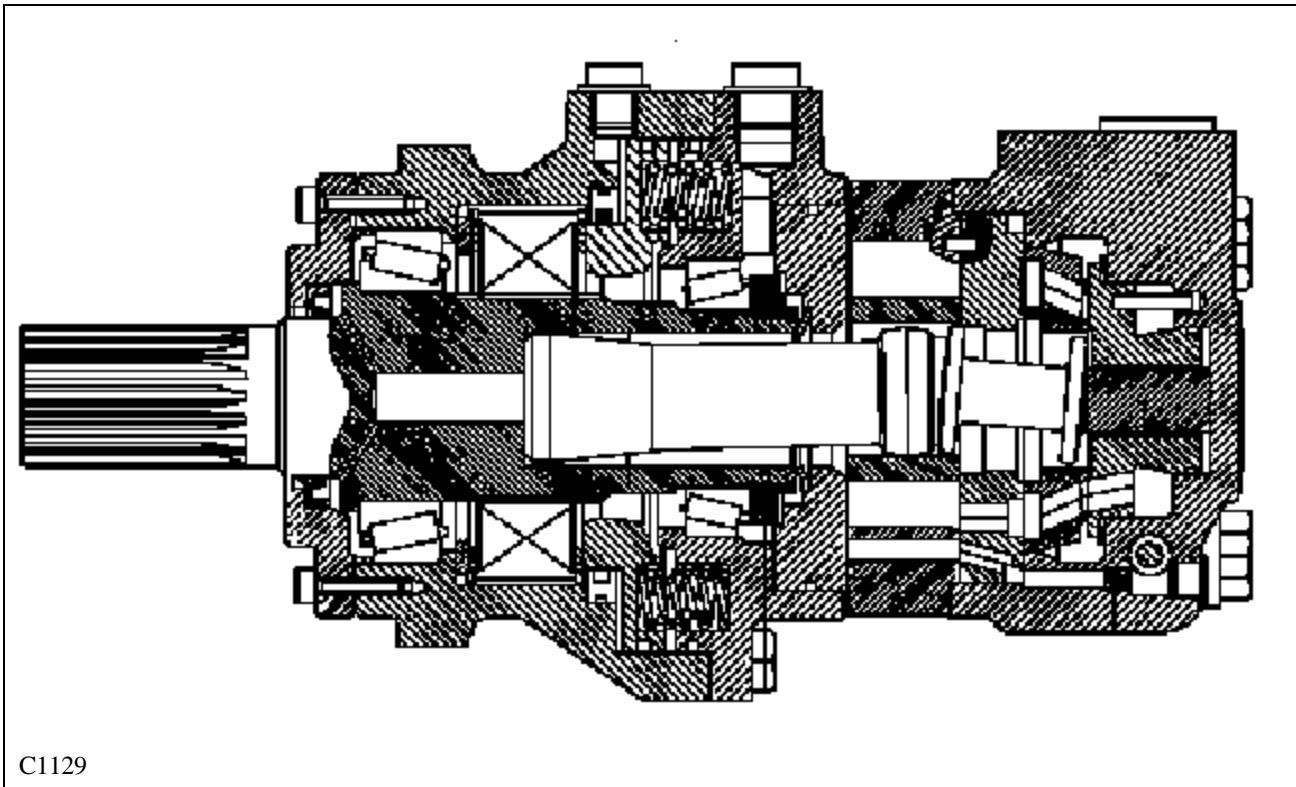

Fluid enters the housing through the inlet port and is directed to the balance plate. The balance ring contains an inner and outer seal to separate the high and low pressure fluid passages. Fluid passes through the stationary balance plate to the rotating disc valve. The rotating disc valve ports the fluid to the stationary valve plate and the proper side of the geroler pockets causing the rotor star to turn.

As the rotor star rotates, and each fluid pocket reaches its full open position, the return porting in the rotating disc

valve opens to allow the fluid in the pocket are to pass back through the valve plate, disc valve, balance plate and out through the housing return port, as the pocket closes.

The disc valve is timed to the geroler rotor star to govern the the inlet fluid flow to the output shaft rotation. If the timing of the disc valve to the geroler star is off one tooth, the relationship of input fluid flow to output motor shaft rotation will be reversed.

DRIVE MOTOR 2.12

Removal

1 Remove any attachment, raise the boom arms and engage the boom support pins.

WARNING

To prevent personal injury do not work under the boom arms without the boom supports engaged.

- 2 Raise the loader securely off the ground.
- 3 Remove the wheels on the side to be repaired.
- 4 Drain the oil from the final drive housing. Be prepared to contain approximately 7 litres (1.9 gal) of fluid. (fig. C1888)
- 5 Remove the seat and hydrostatic shield.
- 6 Remove the final drive inspection cover located between the axles of the final drive housing. (fig. C2424)
- 7 Disconnect the chain as outlined in Section 3. (fig. C2424).
- 8 Remove the 2 high pressure hoses from the drive motor. (fig. C2360a) Cap the open hose ends and fittings to prevent contamination.

IMPORTANT

When making repairs to the hydraulic system, keep the work area and parts clean. Use caps and plugs on all open line and ports.

- 9 Disconnect the 2 brake line hoses and cap the hoses and adapter fittings in the drive motor. (fig. C2360b)
- 10 Remove the adapter fittings from the drive motor. Plug the open ports in the drive motor to prevent contamination.

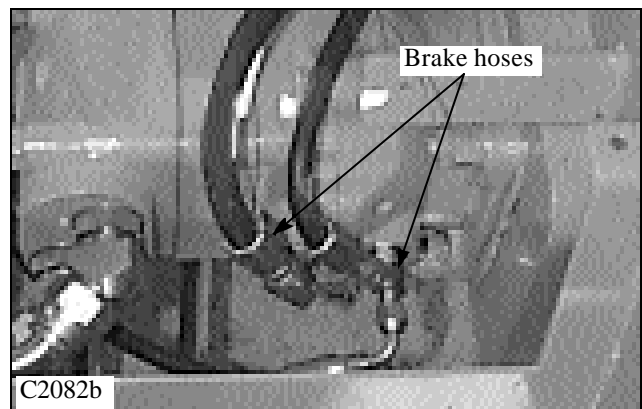
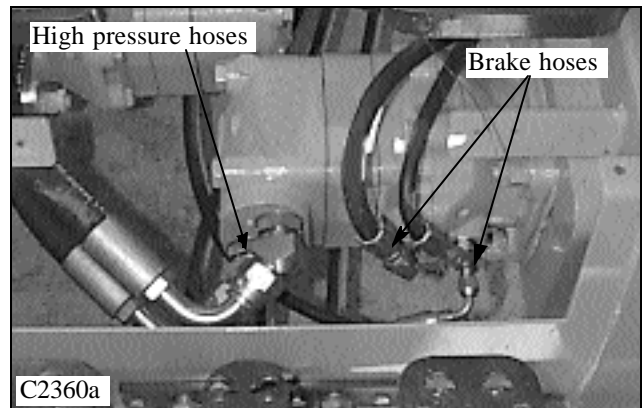
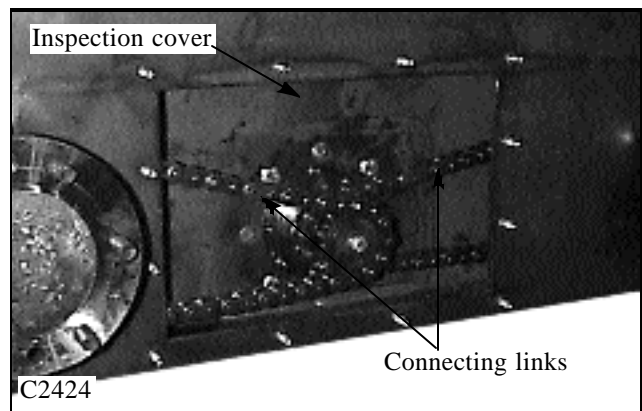
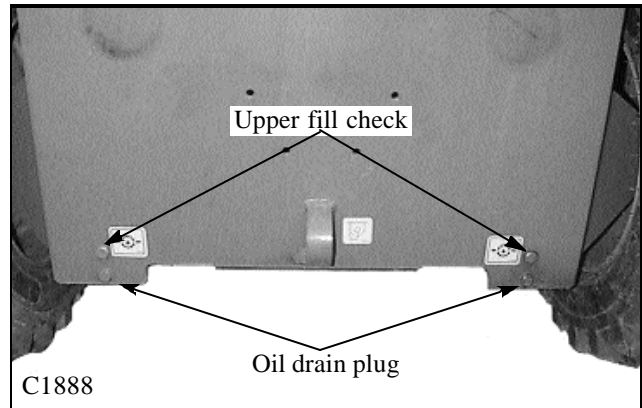

DRIVE MOTOR 2.12

Removal

12 Remove the jam nuts, mounting nuts and lock washers from the 4 mounting bolts retaining the drive motor to the final drive housing. (fig. C2081) Hold the head of the bolts from inside the final drive housing. (fig. C2077)

13 Remove the drive motor. Seal the drive motor with silicone upon reassembly.

14 Upon reassembly torque the 4 mounting nuts to 80 lbs / ft.

15 If the drive motor replacement is being performed because of major parts failure, such as geroler damage, the hydraulic system must be checked for contamination and flushed if necessary as outlined in Section 2.7.

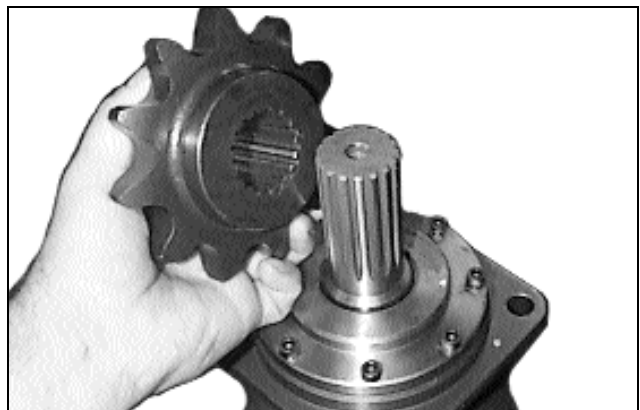
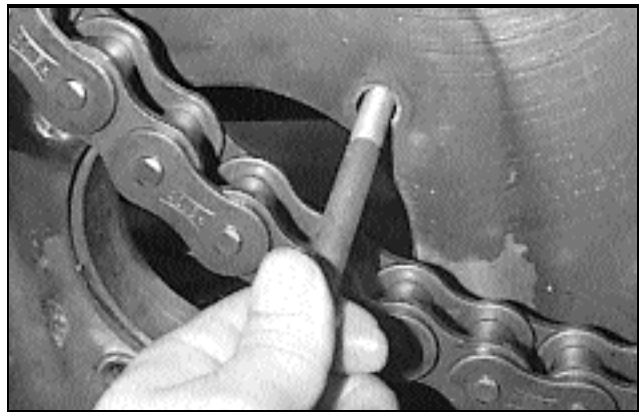
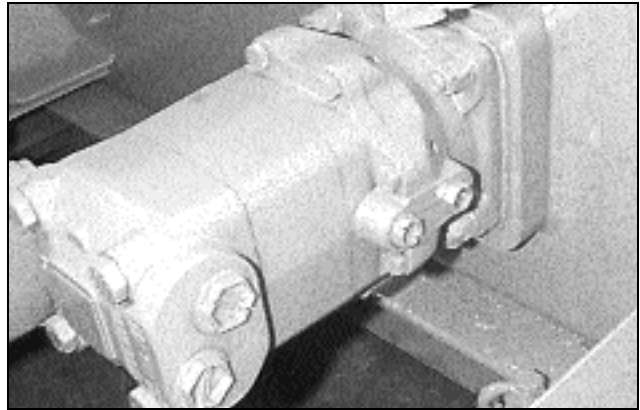

Apply loctite →

DRIVE MOTOR 2.12

Replacement

1 Clean the mounting areas thoroughly that need to be sealed with silicone. (fig. C2078, C2424)

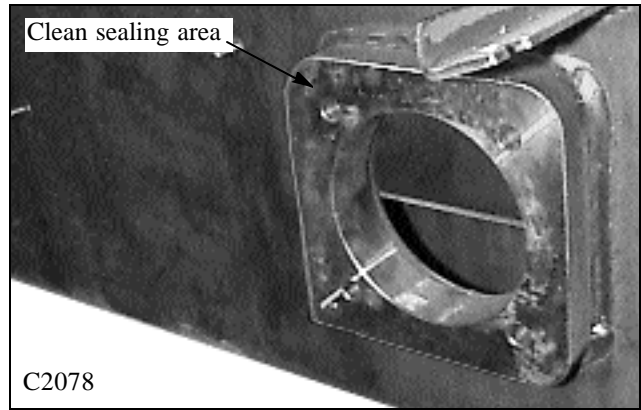

2 Apply a bead 1 / 4 of an inch thick around the drive motor bearing retainer and around each mounting hole. (fig. C2619)

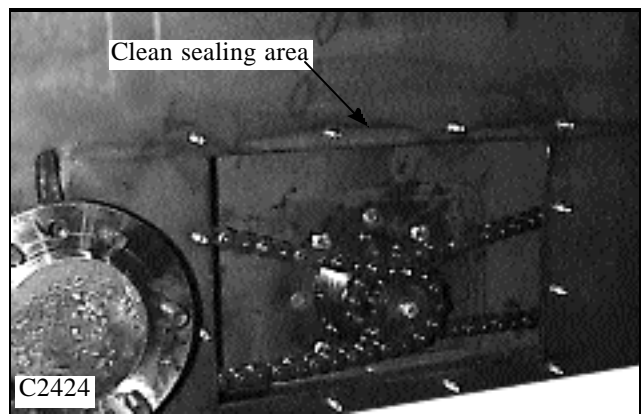

3 Install the drive motor and sprocket assembly to the final drive housing.

4 Install the 4 bolts, lockwashers and mounting nuts and torque to 80 lbs / ft. (115 nm.)

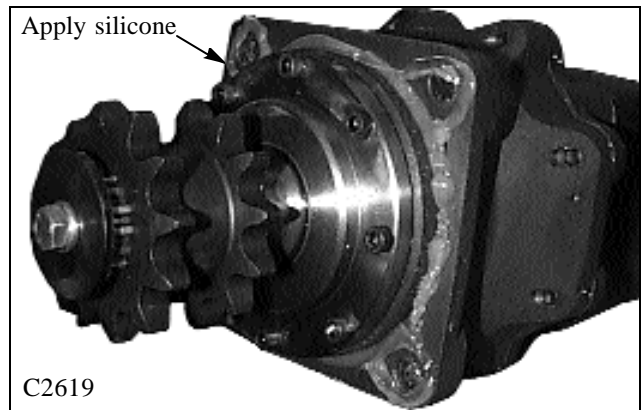

5 Install the 4 jam nuts. Torque the jam nuts to 40 ~ 60 lbs / ft. (54 ~ 81 nm.)

6 Replace the master link in the dive chain. Section 3. shows chain replacement procedure.

7 Add oil to the final drive housing unit it trickles out the upper check plug hole. This will require approximately 7 litres (1.9 gal) of 10w30 API SE/ CD oil. (fig. C1888)

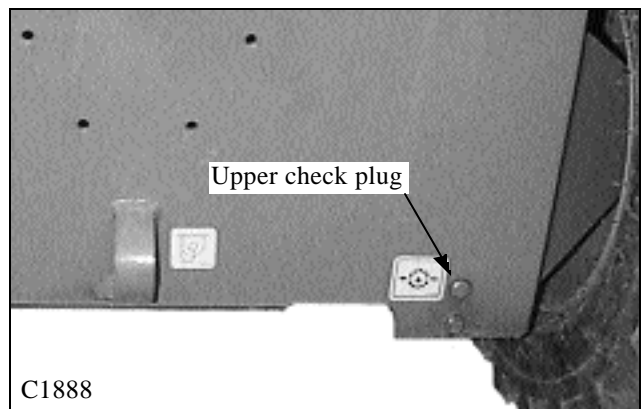

2

DRIVE MOTOR 2.12

IMPORTANT

Refer to the torque chart in Section 8 when tightening hydraulic hoses and fittings

IMPORTANT

Inspect fitting o-rings and flares for marks or damage. Replace if necessary.

- 8 Install the adapter fittings to the drive motor.
- 9 Install the brake lines to the drive motor. (fig. C2360a)
- 10 Install the high pressure drive hoses. (fig. C2360b)
- 11 Clean the final drive housing and inspection cover thoroughly before applying silicone sealant. (fig. C2424)
- 12 Install the inspection cover. When installing the nuts, do not over tighten. The mounting torque should not exceed 11 lbs / ft. (15 N.m.)
- 14 Start the engine and check for hydraulic leaks. Do not use your hands to trace hydraulic leaks. Shut off the engine and inspect each fitting for proper torque.

WARNING

To prevent personal injury never make repairs to the hydraulic system while the engine is operating. Use caution when dealing with hydraulic fluid under pressure. Escaping fluid under pressure can penetrate the skin and cause serious injury.

- 15 Install the wheels and torque the nuts at 100 to 110 lbs / ft. (136 to 149 nm.)
- 16 Install shields and seat, let loader down to ground and test drive to check performance.

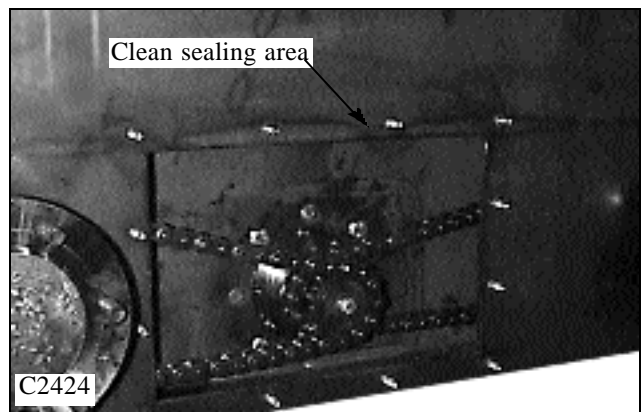
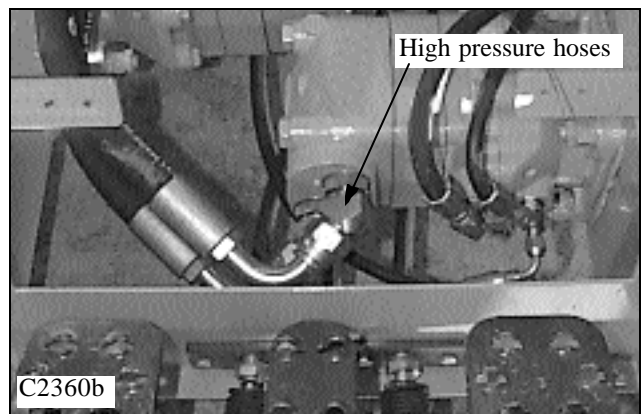
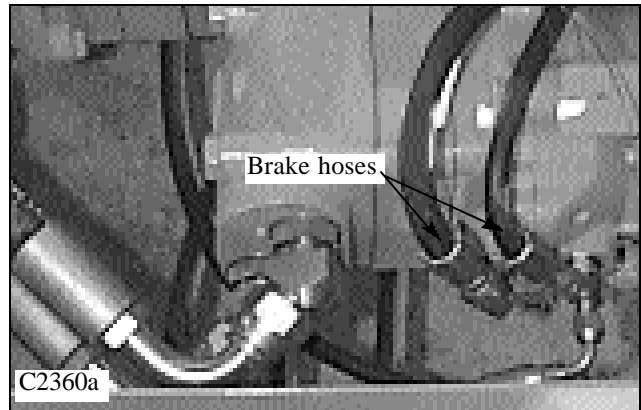

2

DRIVE MOTOR 2.12

Parts Illustration

2

Danfoss OMT FL Diagram C1892 Index

1. Name plate
2. Bolts
3. Valve housing
4. Spring washer
5. Spacer
6. O-ring seal
7. O-ring seal
8. Valve drive shaft
9. Channel plate
10. Disc valve
11. Balance plate
12. Guide pin
13. O-ring seal
14. Guide pin
15. Gearwheel set
16. Intermediate plate
17. O-ring seal
18. Conical seal ring
19. Cardan shaft

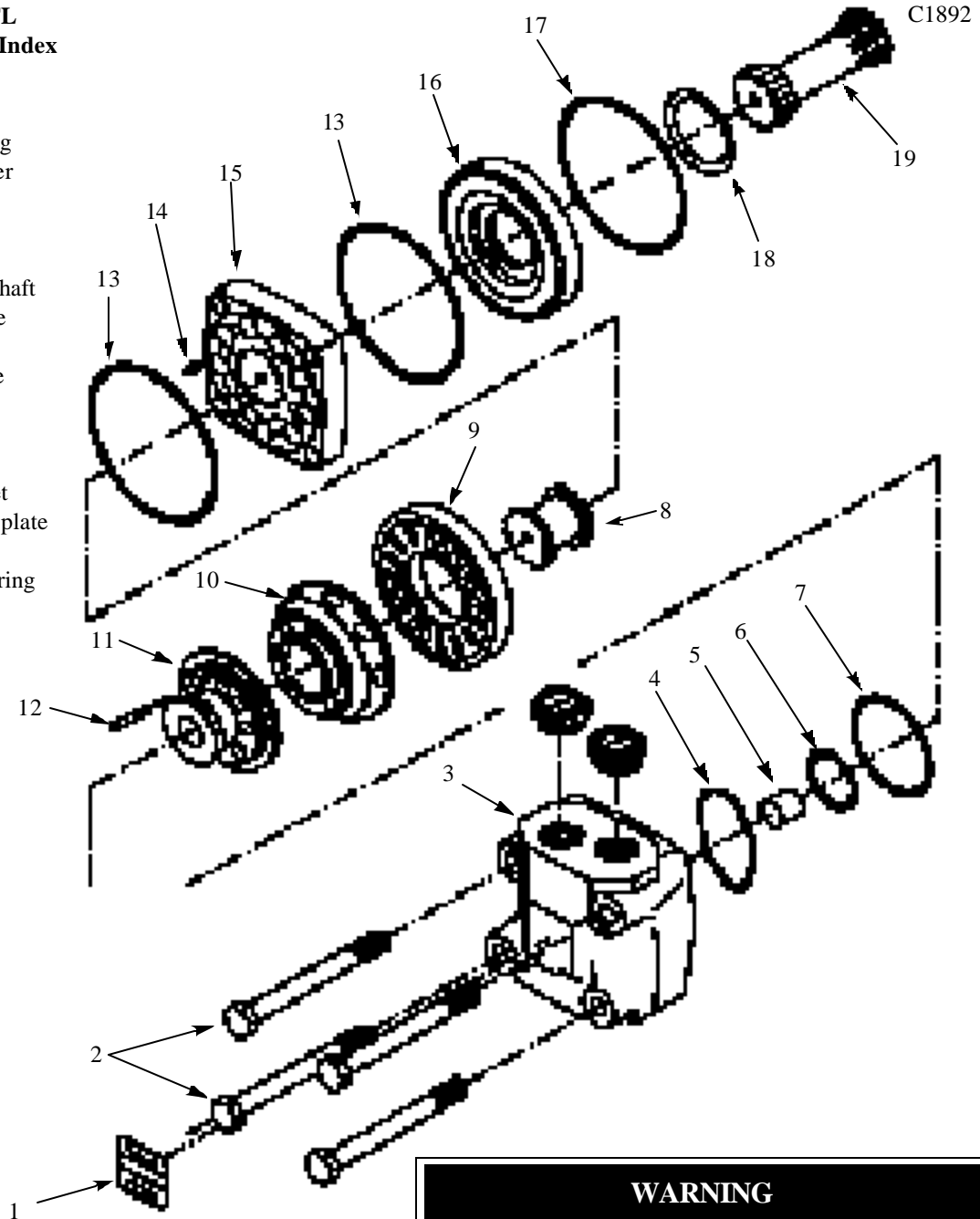

WARNING

To avoid eye injury, use safety goggles when cleaning with compressed air.

IMPORTANT

When making repairs to the hydraulic system, keep the work area and parts clean. Use caps and plugs on all open line and ports.

Fig. C1892 shows an exploded view of the hydraulic torque motor. Before disassembling the torque motor, clean the outer surface of all loose dirt and grease and dry with compressed air. Be sure all openings are plugged to prevent solvent or soap entering the torque motor.

DRIVE MOTOR 2.12

Parts Illustration

Danfoss OMT FL Brake Diagram C1893 Index

1. Bearing nut
2. Bearing, small
3. Screw
4. Bearing housing
5. O-ring seal
6. Spring
7. Spring
8. Piston
9. O-ring seal
10. Ring
11. O-ring seal
12. O-ring seal
13. Inner brake disc
14. Outer brake disc
15. Spacer disc
16. Bearing housing
17. Bearing
18. Splined shaft
19. O-ring seal
20. Shaft seal
21. Front cover
22. Dust seal ring
23. Screws

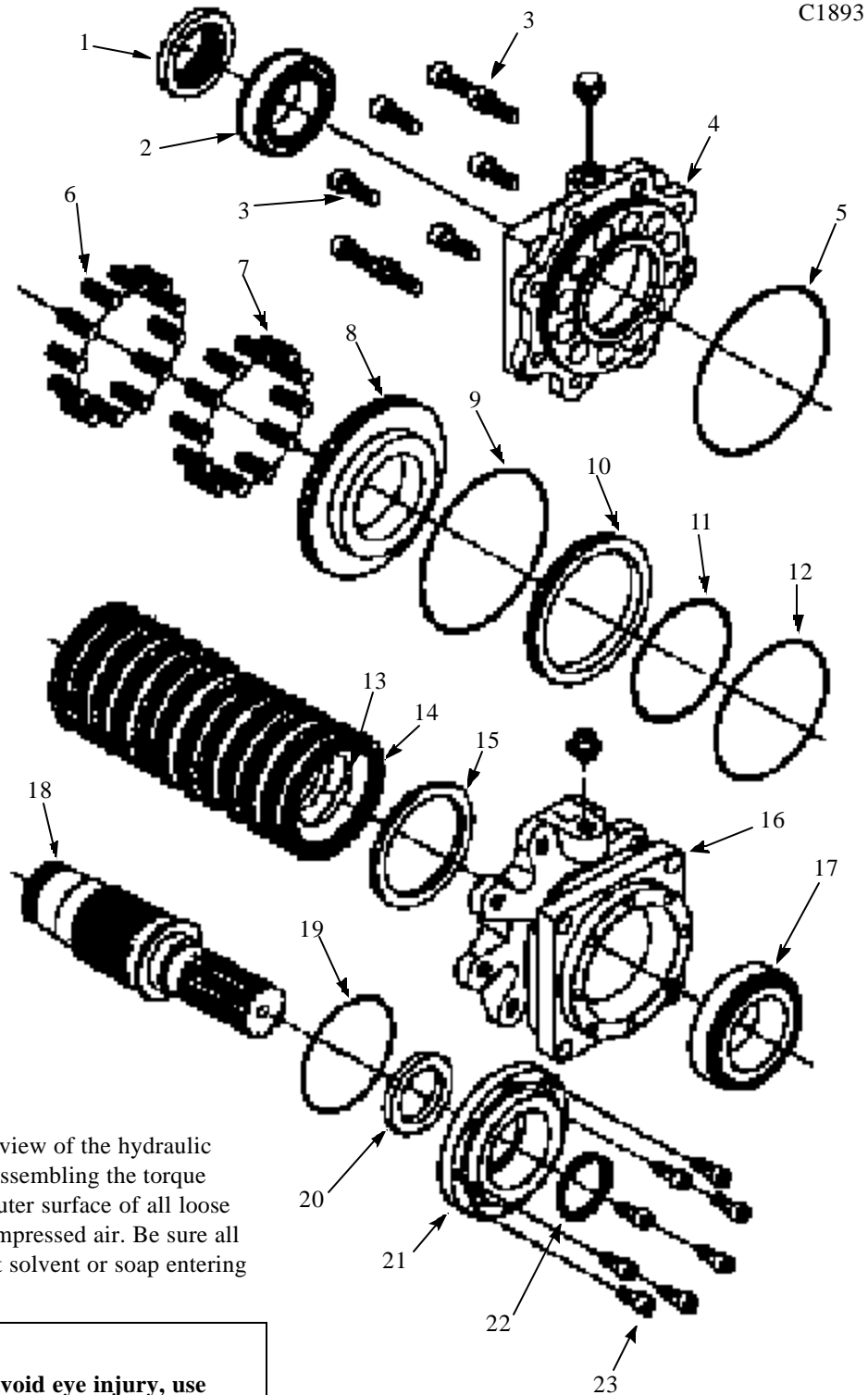

Fig. C1893 shows an exploded view of the hydraulic torque motor brake. Before disassembling the torque motor and or brake, clean the outer surface of all loose dirt and grease and dry with compressed air. Be sure all openings are plugged to prevent solvent or soap entering the torque motor.



To avoid eye injury, use safety goggles when cleaning with compressed air.

DRIVE MOTOR 2.12

Disassembly

- 1 Place the drive motor in a vise with the output shaft facing down. Clamp the motor to the vise, holding it by the mounting flange area. Do not clamp the motor on the housing as excessive pressure will cause distortion.
- 2 Mark a line across the various sections of the drive motor to assist in reassembly. (fig. C2287)

2

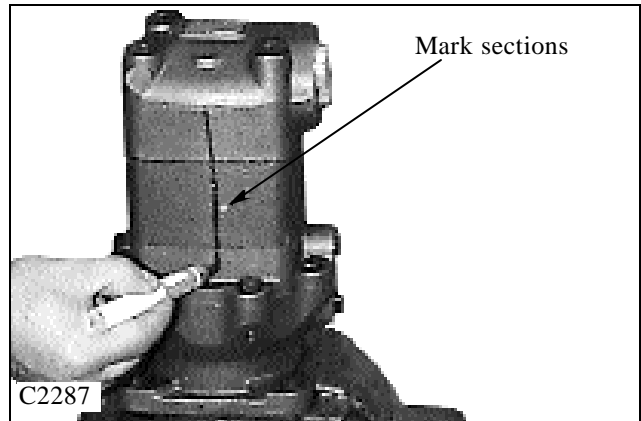

- 3 Remove the small allen head socket plug located between two of the section bolts.(fig. C2288)

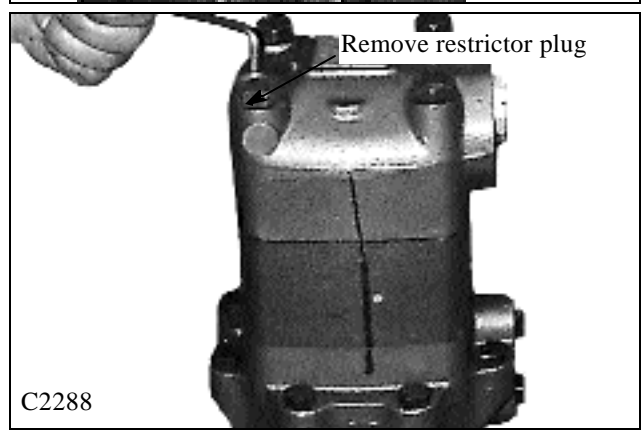

- 4 Insert an allen wrench into the open hole and remove the set screw restrictor. (fig. C2289)

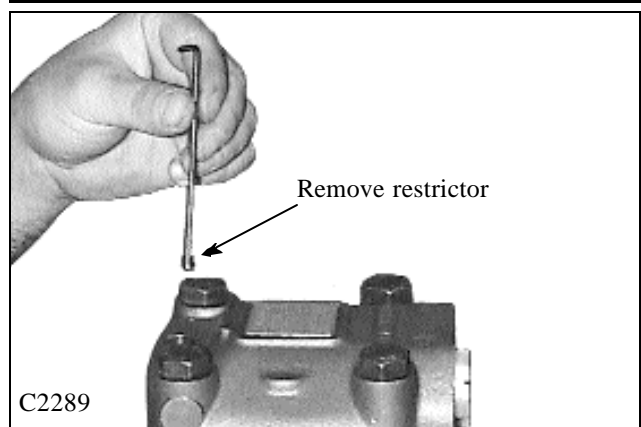

- 5 Remove the 4 bolts from the drive motor valve housing. (fig. C2290) Upon reassembly, torque the bolts in a criss cross pattern at 130 ~ 135 ft/lbs. (177 ~ 183.5 N.m.)

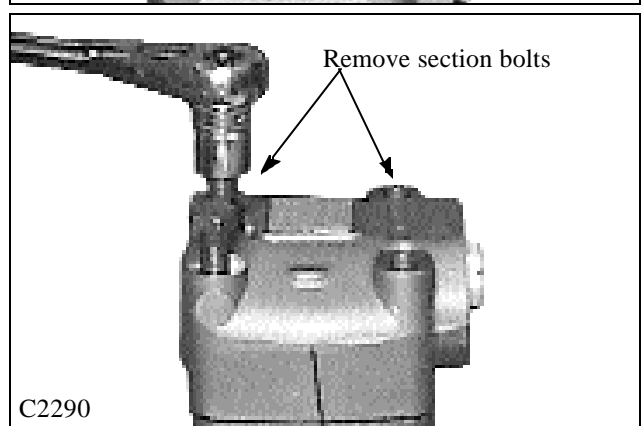

DRIVE MOTOR 2.12

Disassembly (cont'd)

6 Insert a small screwdriver into the mounting holes of the valve housing assembly and remove the 2 shuttle valve plugs, one each side. (fig. C2291, 2293)

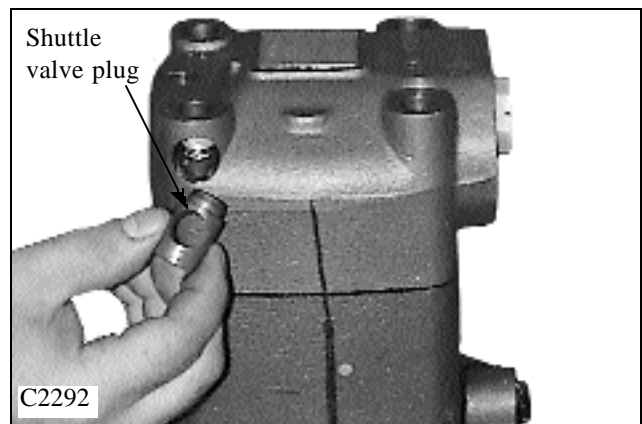
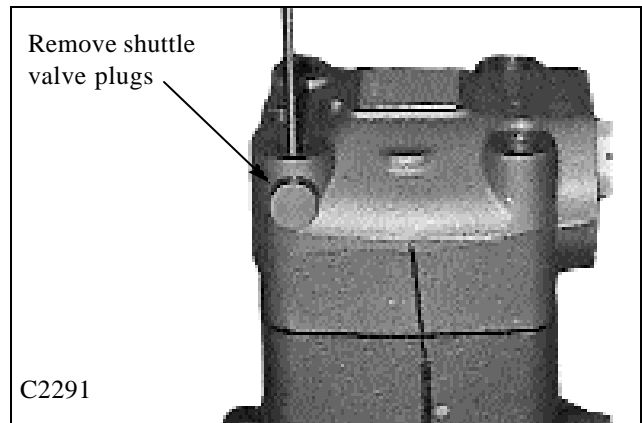

7 Insert a small screwdriver into the shuttle valve plug hole and retrieve the springs. (fig. C2293) There is one on either side.

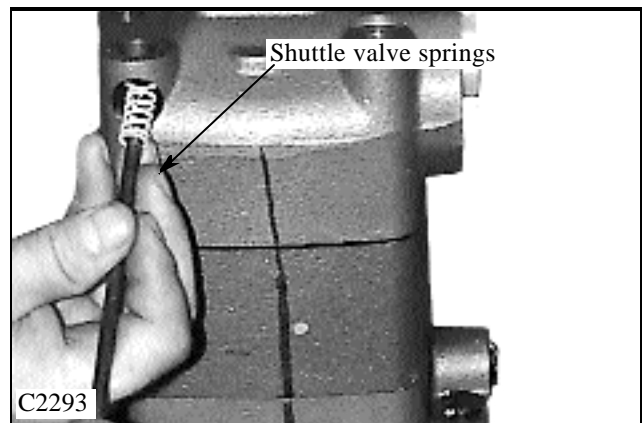

8 Push out the shuttle valve poppet using the screwdriver. (fig. C2294)

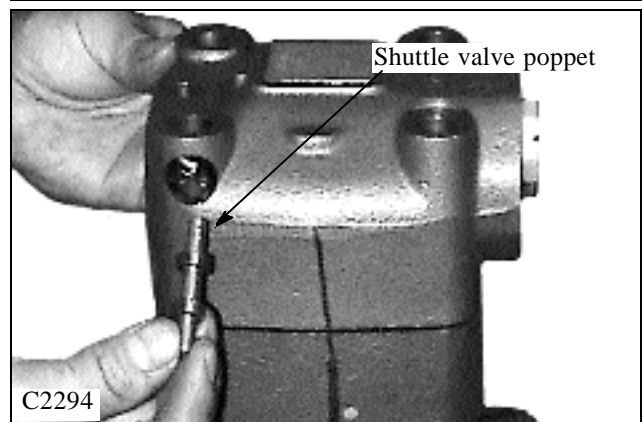

2

DRIVE MOTOR 2.12

Disassembly (cont'd)

9 Carefully lift the valve housing straight up. (fig. C2295) Place your fingers under the valve housing to hold the channel plate in place.

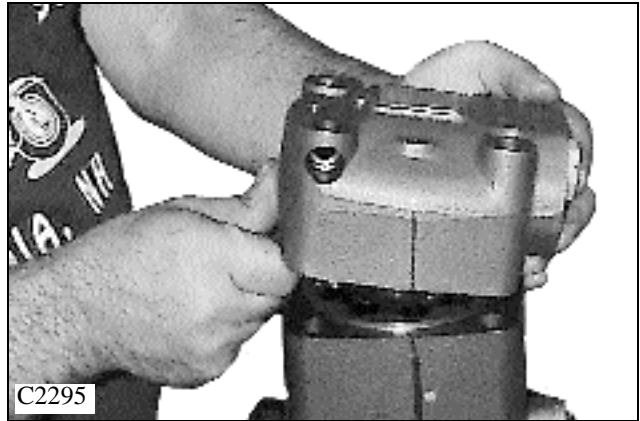

10 Remove the channel plate. (fig. C2296)

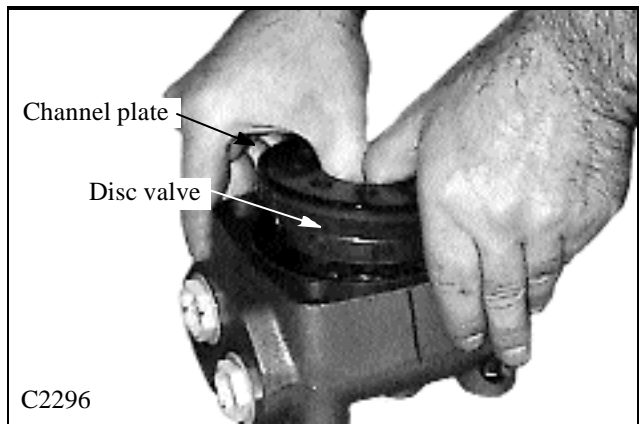

11 Remove the disc valve and balance plate from the valve housing section. (fig. C2297, C2298)

12 Inspect the parts for wear and replace as required. Replace all seals with new when assembling the drive motor.

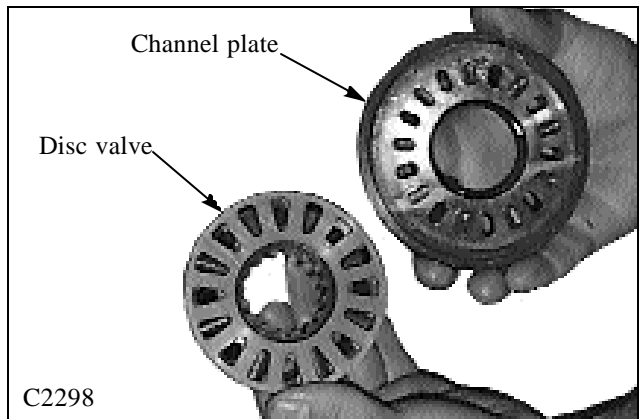
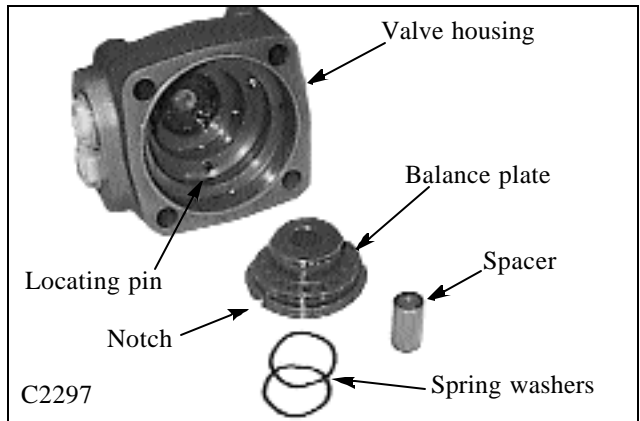

2

DRIVE MOTOR 2.12



C2303

DRIVE MOTOR 2.12

Disassembly (cont'd)

- 15 Remove the cardan (drive) shaft (fig. C2304).
- 16 Remove the intermediate spacer (fig. C2305).
- Replace the seal with new item at time of assembly.

2

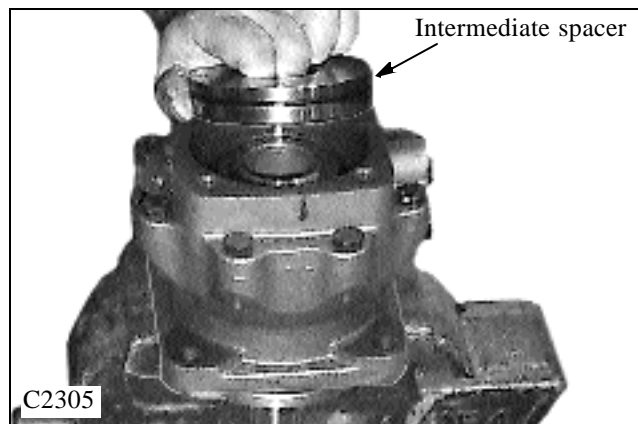
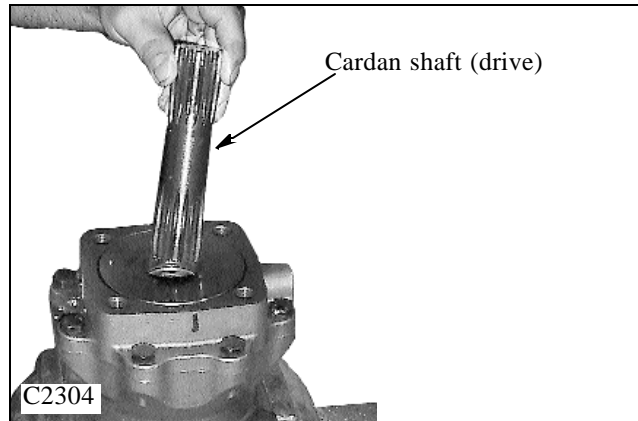

- 17 A special tool will be required as shown in fig. C2306 to remove the bearing nut (fig. C2307). Tool shown was made using 1/2 in. X 1 in. X 3 in. long (12mm x 25mm x 76mm L) material. Two holes were drilled and tap 60mm apart, to accept 6mm X 30mm machine screws.

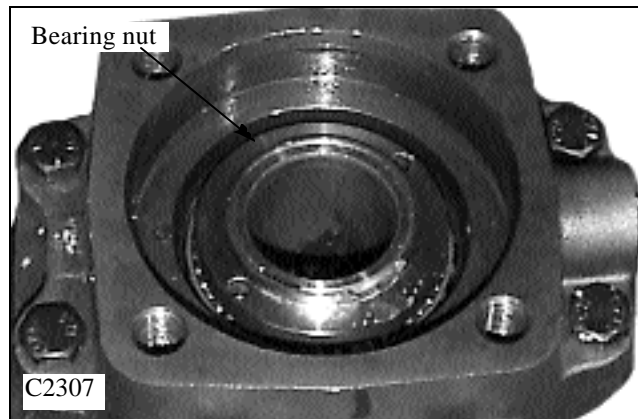
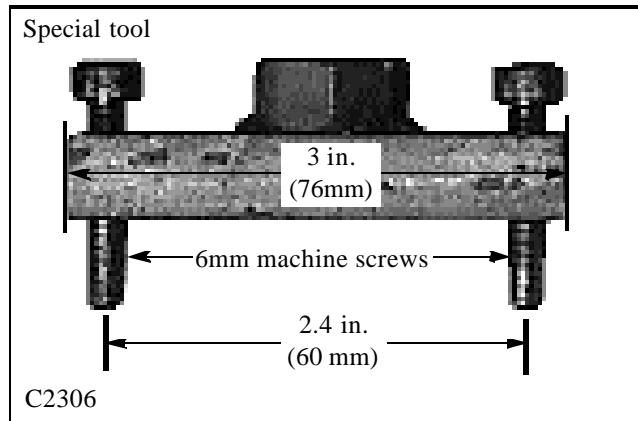

DRIVE MOTOR 2.12

Disassembly (cont'd)

18 Place the special tool on the bearing nut and remove the bearing nut. (fig. C2308, C2309).

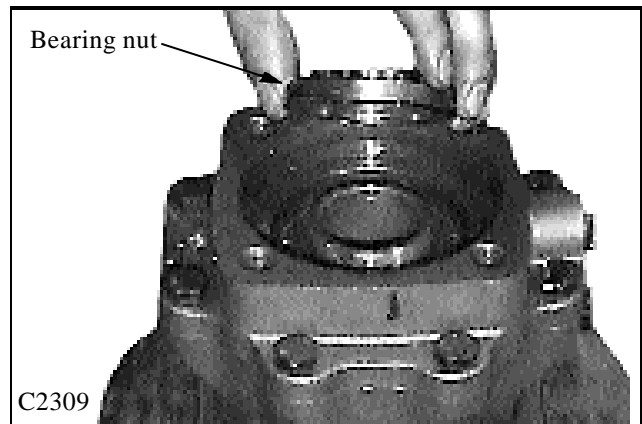
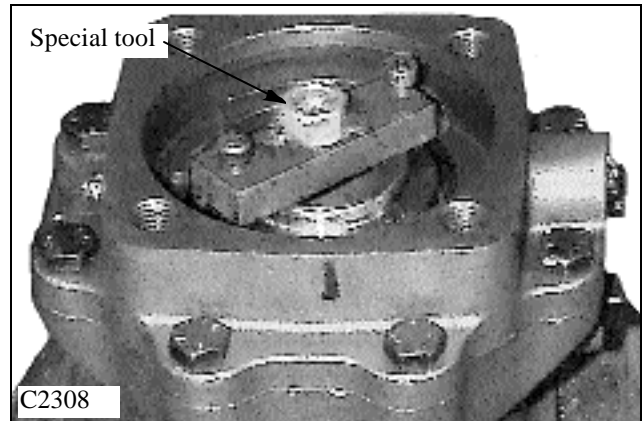

19 Remove the drive motor from the vise and remove the screws retaining the front cover to the bearing housing. (fig. C2310, C2311). Replace the seals with new at time of assembly.

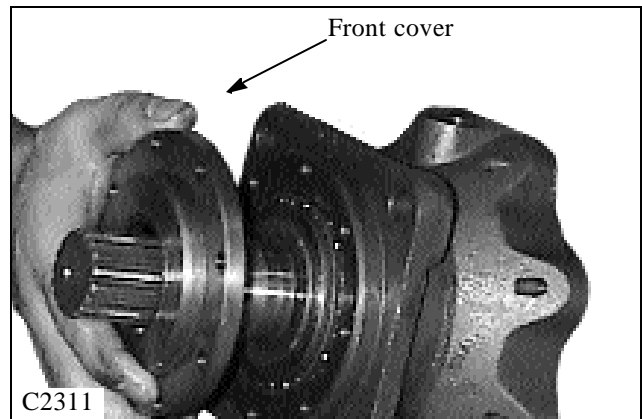
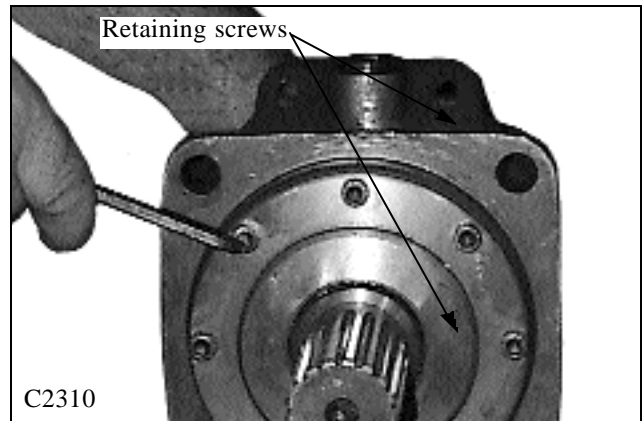

2

DRIVE MOTOR 2.12

Disassembly (cont'd)

20 Use a press and appropriate sized arbor to push the output shaft from the bearings. (fig. C2312).

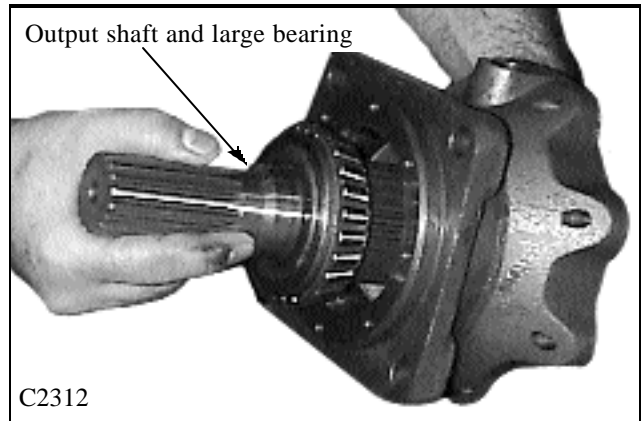

21 Remove the small bearing from the housing. (fig. C2313). Inspect both bearings and races. Replace as required.

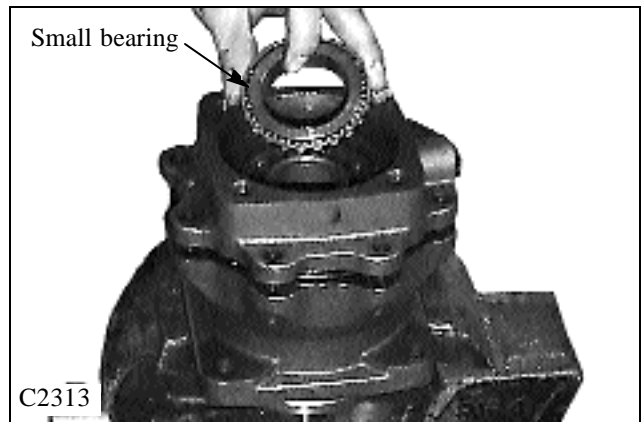

22 Remove the bolts from the around the bearing housing. (fig. C2314).

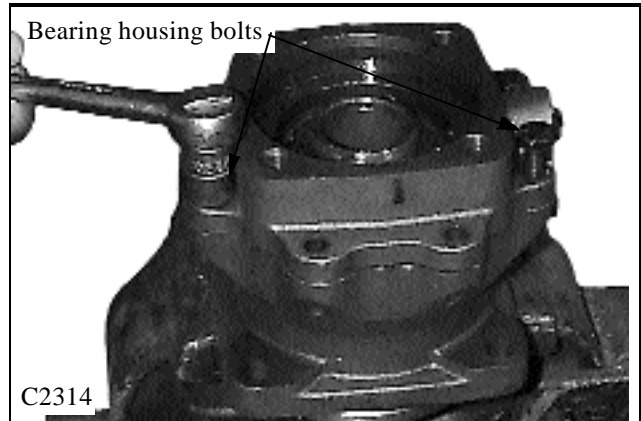

23 Separate the bearing housing sections. (fig. C2315) A mallet may be required to assist removal.

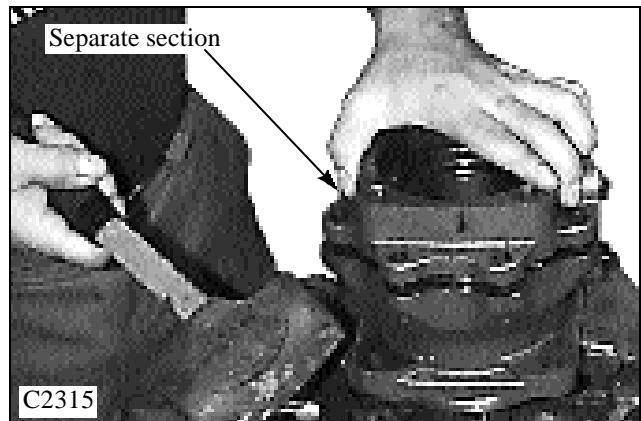

2

DRIVE MOTOR 2.12

Disassembly (cont'd)

24 Remove the bearing housing (fig. C2316).

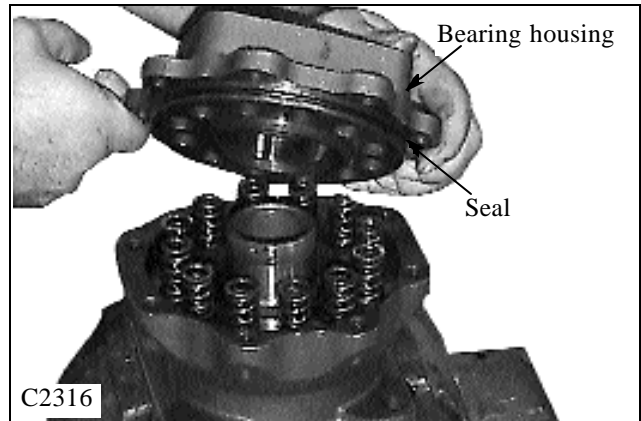

25 Remove the brake springs from the brake piston. (fig. C2317) There are inner and outer springs.

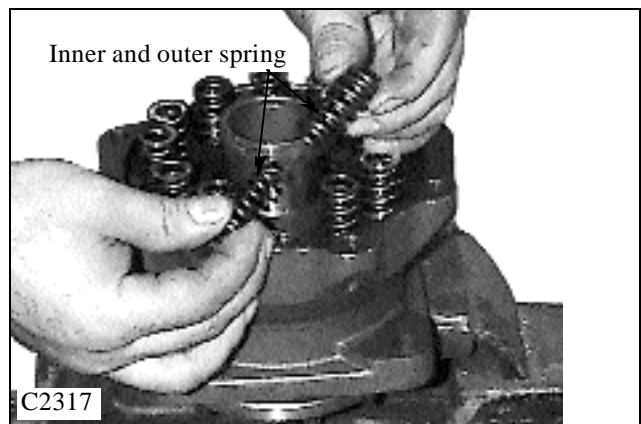

26 Remove the piston from the housing by pushing through from the output shaft side. (fig. C2318)

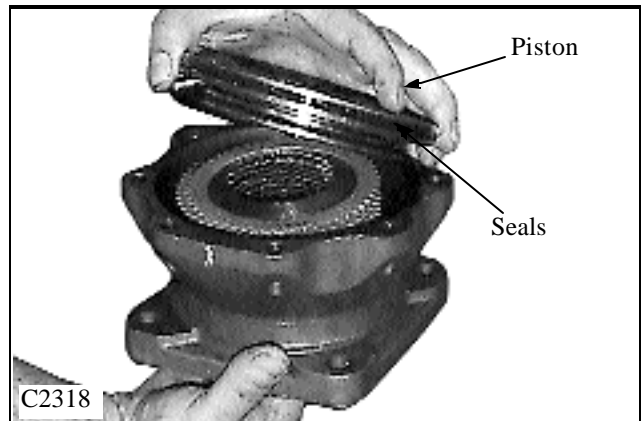

27 Remove the brake disc assemblies. Note the positions of the steel and fibre plates. (fig. C2319). Check the plates for wear and replace as required.

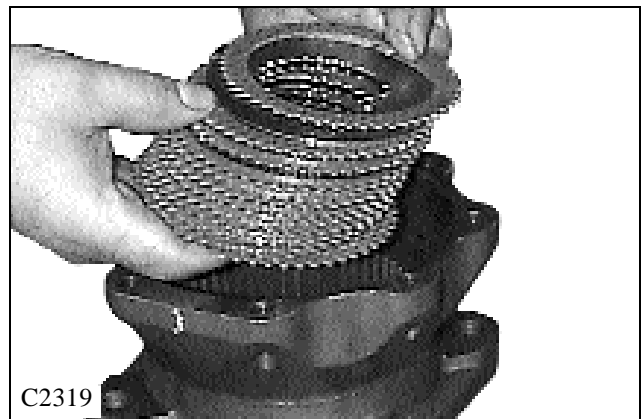

2

DRIVE MOTOR 2.12

Assembly

1 Install the output shaft to the housing. (fig. C2321)

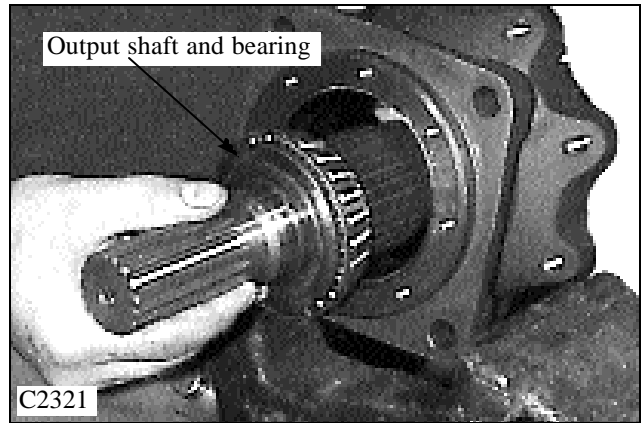

2 Install the front cover to the housing and torque the screws to 12 Nm. (8.9 lbs / ft) (fig. C2322). Use new seals when assembling the motor.

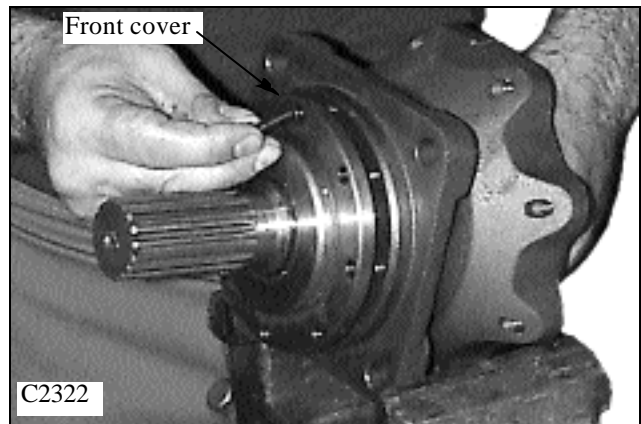

3 Install the brake disc spacer ring to the housing. (fig. C2320)



4 Install the brake disc plates. (fig. C2323, C2324, C2319) Start with a fibre plate, add a steel plate, then fibre and so on until the last plate to be installed is a fibre plate.

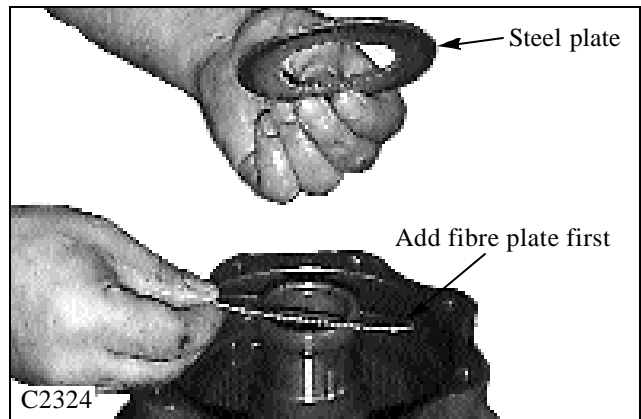

IMPORTANT

NOTE: The fibre plates are also called outer plates due to the “teeth” outside of the plate.

DRIVE MOTOR 2.12

Assembly

5 Continue adding plates, 12 fibre, 11 steel plates, to the housing. (fig. C2323, C2319)

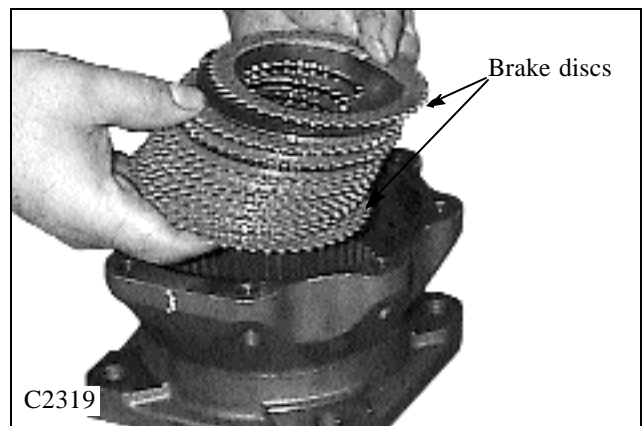
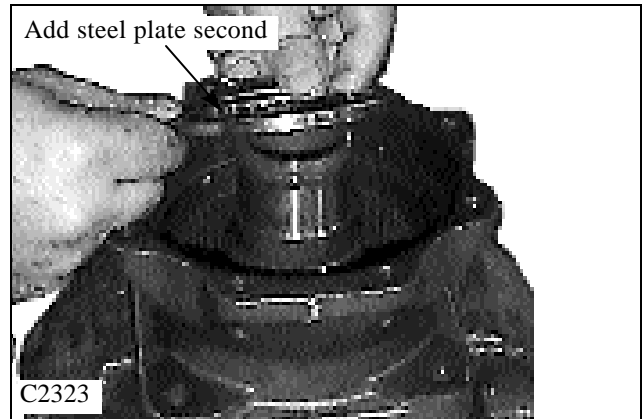

6 Install the piston to the housing, over the brake discs. (fig. C2318) Use new seals when assembling the motor. Align one of the piston spring pockets with the hydraulic inlet port opening in the housing. (fig. C2316)

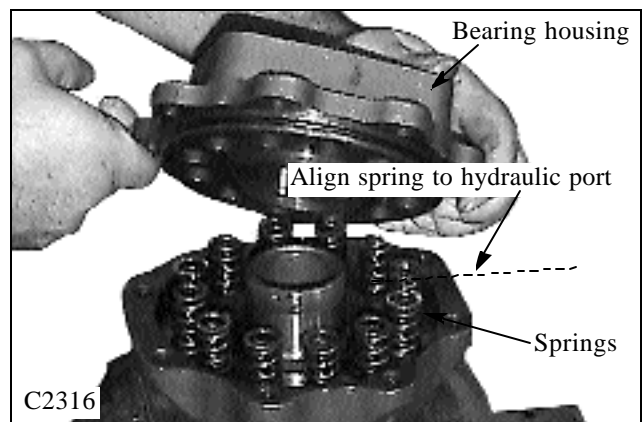
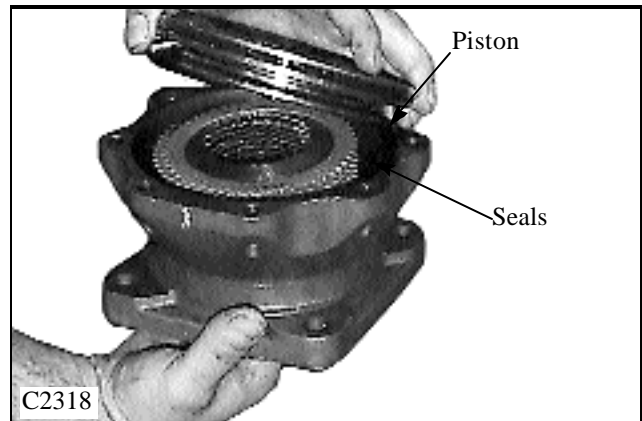

2

DRIVE MOTOR 2.12

Assembly (cont'd)

7 Install the bearing housing bolts and torque to 46.5 lbs / ft. +/- 2 lbs / ft. (63 Nm +/- 3 Nm) (fig. C2314)

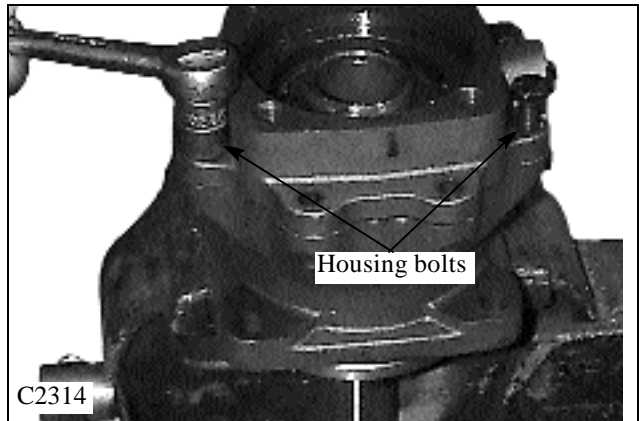

8 Install the small bearing to the output shaft (fig. C2313) in the following sequence:

a. Apply pressure, 12 bar (175 psi), to the brake ports to release the brakes.

b. Press the bearing onto the output shaft with a force of 350 daN (780 pounds of force), while rotating the housing back and forth. Be sure to press only on the inner race of the bearing.

c. Remove the brake release pressure before removing the force acting on the bearing.

d. Install the bearing nut and torque to 45 lbs / ft. (60 Nm) Strike the nut with blows from a mandrel and hammer to prevent the nut from loosening.

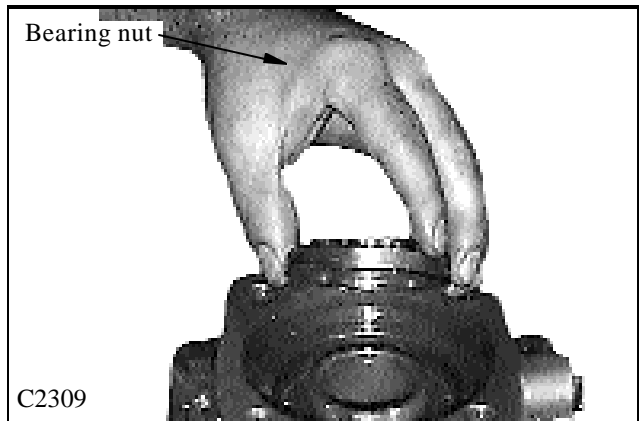
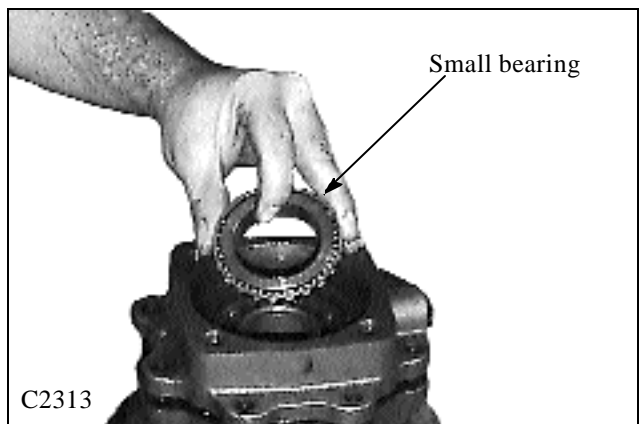

9 Install a new seals to the intermediate plate. (fig. C2325). Apply petroleum jelly to the cup seal to retain in position.

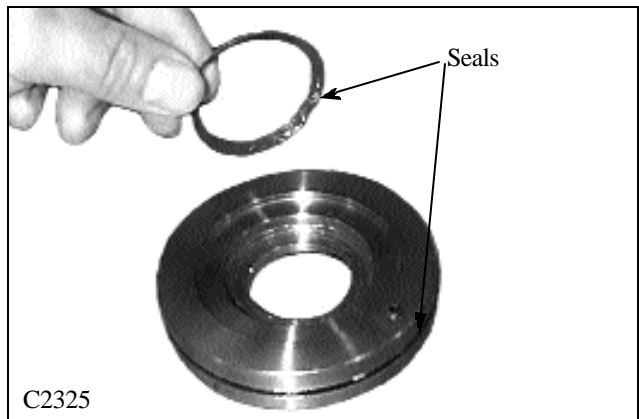

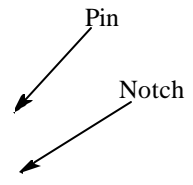

C2326

DRIVE MOTOR 2.12

Assembly (cont'd)

14 Install the geroler section the housing. (fig. C2330)
Place a hand under the geroler to prevent the pieces from falling out.

2

The following procedures must be followed closely for proper motor rotation.

15 Mark the gearwheel set rotor at the point where the top of a spline tooth is opposite the bottom of a tooth in the external rotor teeth. (fig. C2331).

16 Mark the bottom of a spline tooth on the valve drive. (fig. C2332).

17 Install the valve drive lining up the marks on the valve drive to the gearwheel set. (fig. C2333).

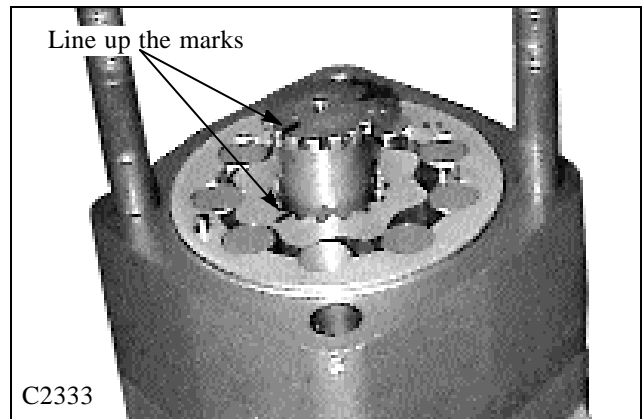
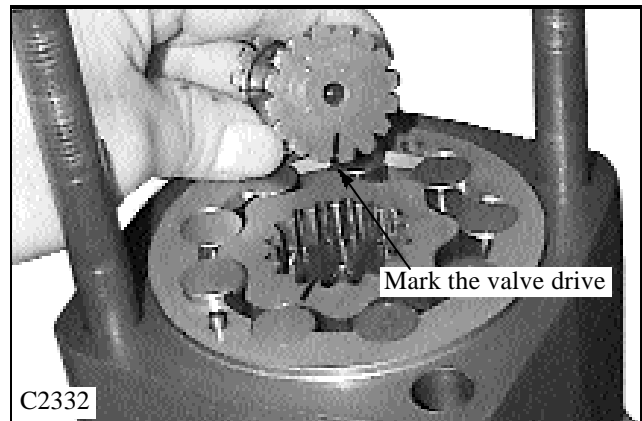
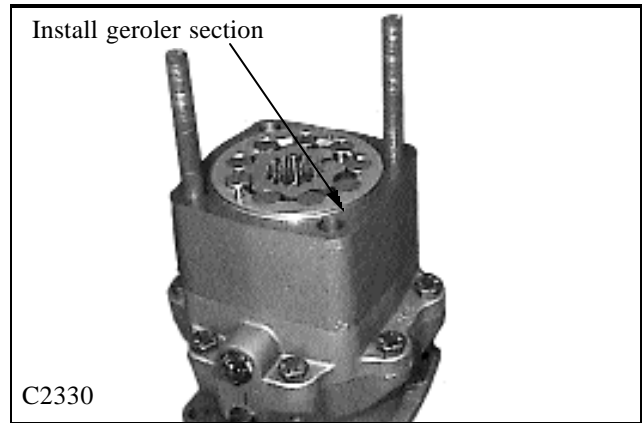

DRIVE MOTOR 2.12

Assembly (cont'd)

18 Install the channel plate to the geroler section. Install new seals when assembling the motor. (fig.C2334) Note the alignment dowel pin and oil passage hole.

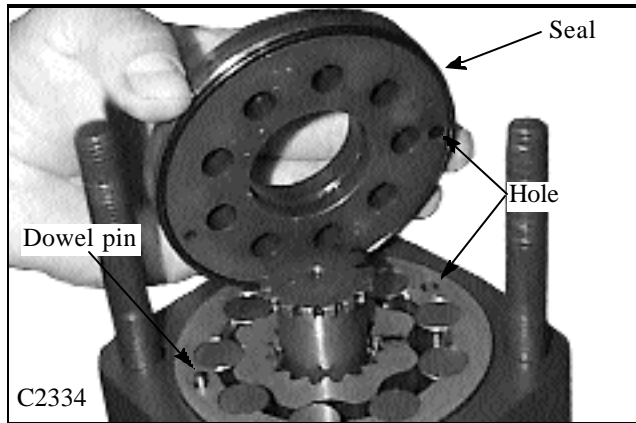

19 Install the disc valve to the valve drive. (fig. C2335) Align the mark on the valve drive with a hole in the outer rim.

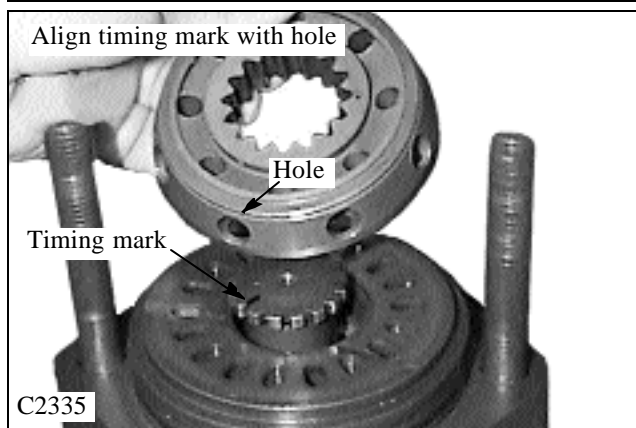

20 Turn the disc valve counter clockwise until the two parts engage. (fig. C2336).

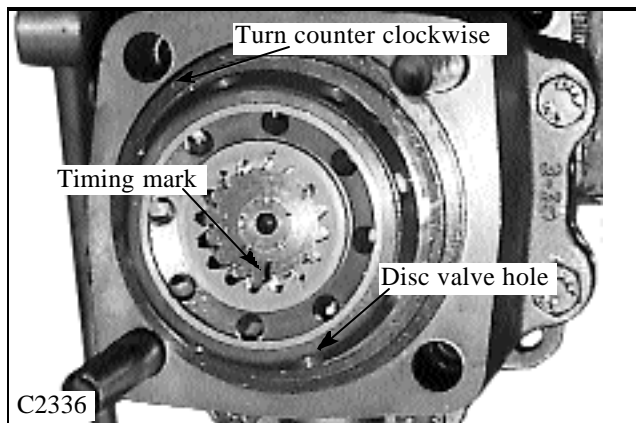

21 Install new seals to the balance plate, install the springs and install the balance plate to valve housing. (fig. C2297). Note the locating pin in the valve housing and the notch in the balance plate.

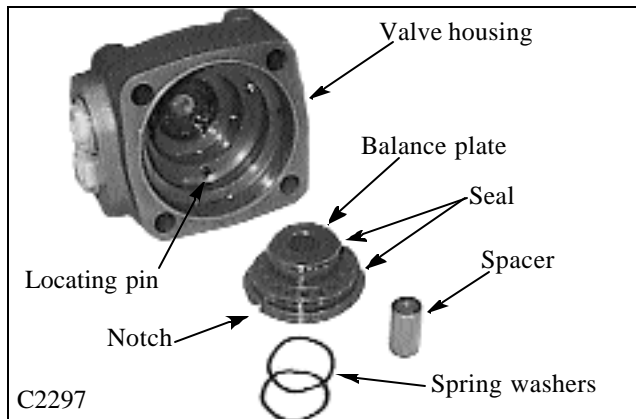

DRIVE MOTOR 2.12

Assembly (cont'd)

- 22 Apply petroleum jelly to the spacer. (fig. C2337)
Install the spacer to the valve housing. (fig. C2338)

2

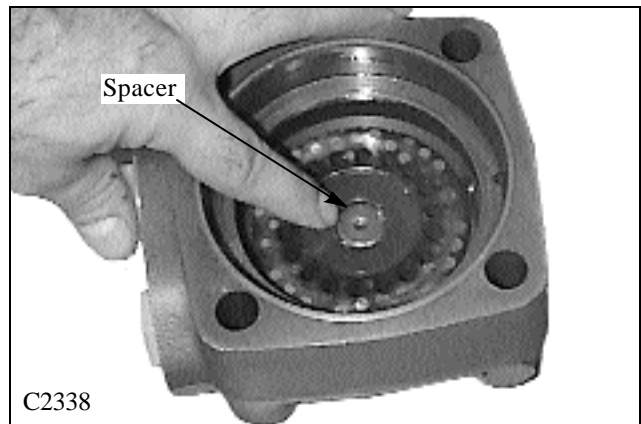
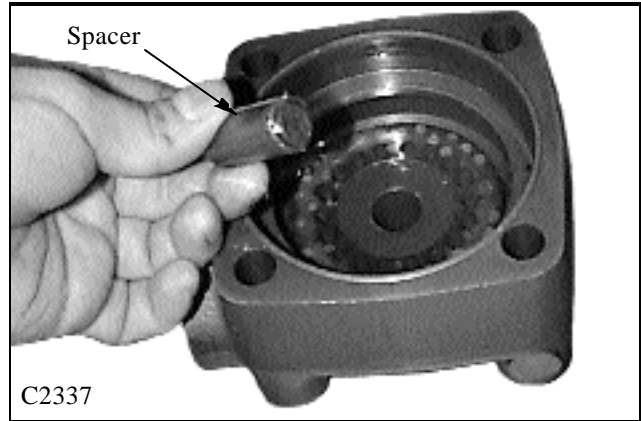

- 23 Install the valve housing to the drive motor. (fig. C2339).

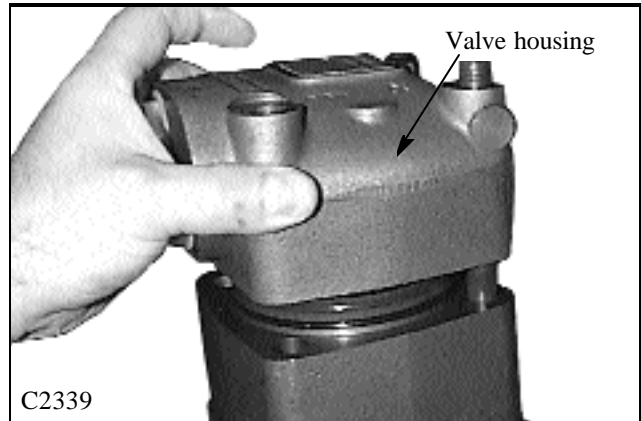

- 24 Install the shuttle valve piston. (fig. C2294).

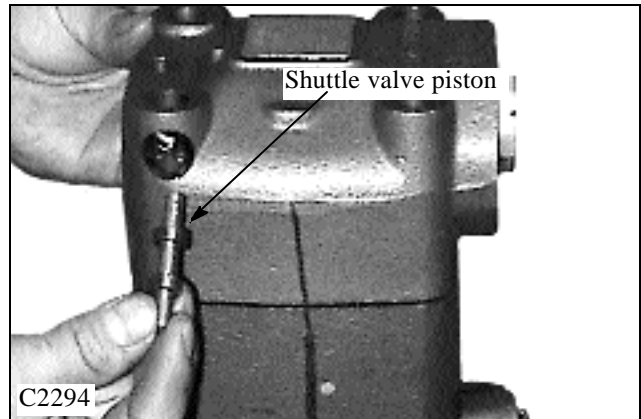

DRIVE MOTOR 2.12

Assembly (cont'd)

25 Install the shuttle valve springs to either side of the piston. (fig. C2293).

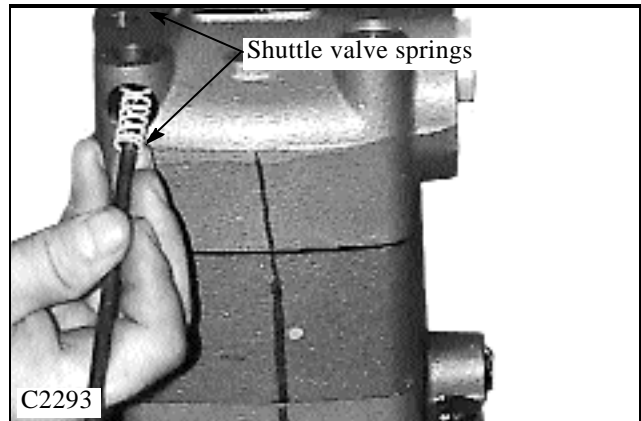

26 Install the shuttle valve plugs. (fig. C2292) Be sure to use new seals when assembling the motor.

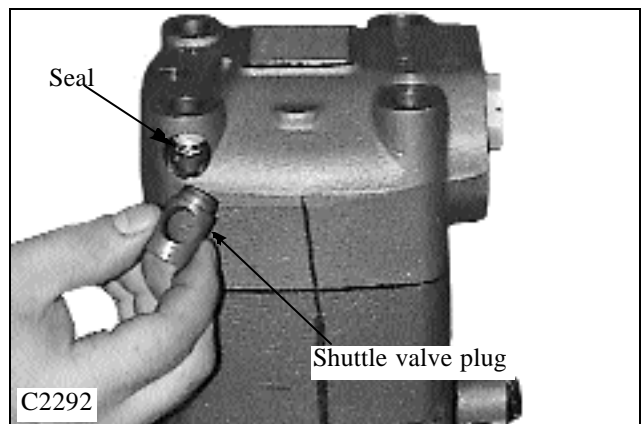

27 Install the bolts to the drive motor and torque in a criss cross pattern to 135 lbs / ft. (183 Nm).(fig. C2290).

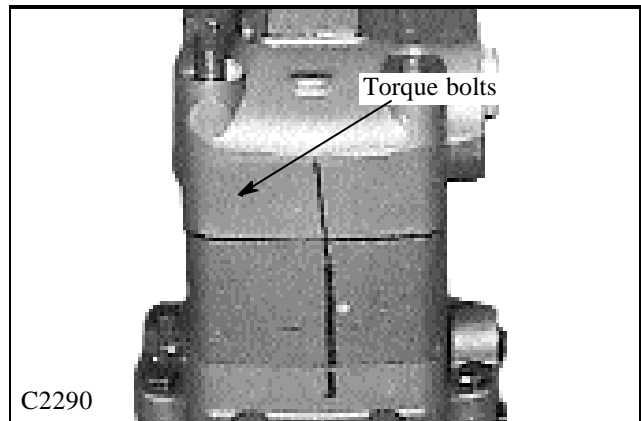

28 Install the restrictor and replace the plug. (fig. C2289).

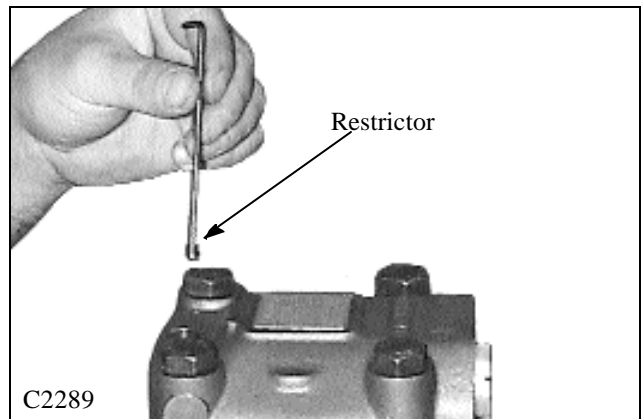

2

2



THOMAS