

# SECTION 1 HYDRAULIC SYSTEM



<b>Hydraulic Circuit</b>	<b>1.1</b>
Schematic .....	pg. 1-2
Specifications .....	pg. 1-3
Maintenance Schedule .....	pg. 1-3
General Information .....	pg. 1-4 ~ 5
<b>Gear Pump</b>	<b>1.2</b>
Replacing the Gear Pump .....	pg. 1-6
Start - up Procedure .....	pg. 1-7
Testing (See control valve relief) .....	pg. 1-14 ~ 15
<b>Control Valve</b>	<b>1.3</b>
Testing / Adjusting the Relief Valve .....	pg. 1-8
Control Valve Removal .....	pg. 1-9
Control Valve Installation .....	pg. 1-10
Exploded Illustration (to S / N LC001080) .....	pg. 1-12 ~ 13
Exploded Illustration (S / N LC001081 onward) .....	pg. 1-15
Control Valve Disassembly / Repair .....	pg. 1-16 ~ 25
<b>Hydraulic Cylinders</b>	<b>1.4</b>
General Information .....	pg. 1-26
Testing Piston Seals .....	pg. 1-27
Lift Cylinder Replacement .....	pg. 1-28
Tilt Cylinder Replacement .....	pg. 1-29
Cylinder Disassembly .....	pg. 1-30 ~ 31
Cylinder Inspection .....	pg. 1-32
Cylinder Assembly .....	pg. 1-32 ~ 33
<b>Hydraulic Oil Filter</b>	<b>1.5</b>
General Information .....	pg. 1-34
Filter Replacement .....	pg. 1-34
<b>Hydraulic Oil Cooler</b>	<b>1.6</b>
General Information .....	pg. 1-35
Oil Cooler Replacement .....	pg. 1-35
<b>Hydraulic Oil Reservoir</b>	<b>1.7</b>
General Information .....	pg. 1-36
Checking the Oil Level .....	pg. 1-36
Adding Oil .....	pg. 1-36
Servicing the Reservoir .....	pg. 1-37
<b>Trouble Shooting</b>	<b>1.8</b>
Trouble Shooting Chart .....	pg. 1-38 ~ 39
<b>Torque Chart</b>	<b>1.9</b>
Hydraulic Hose and Fitting Torque Chart .....	pg. 1-39

# HYDRAULIC CIRCUIT 1.1

1

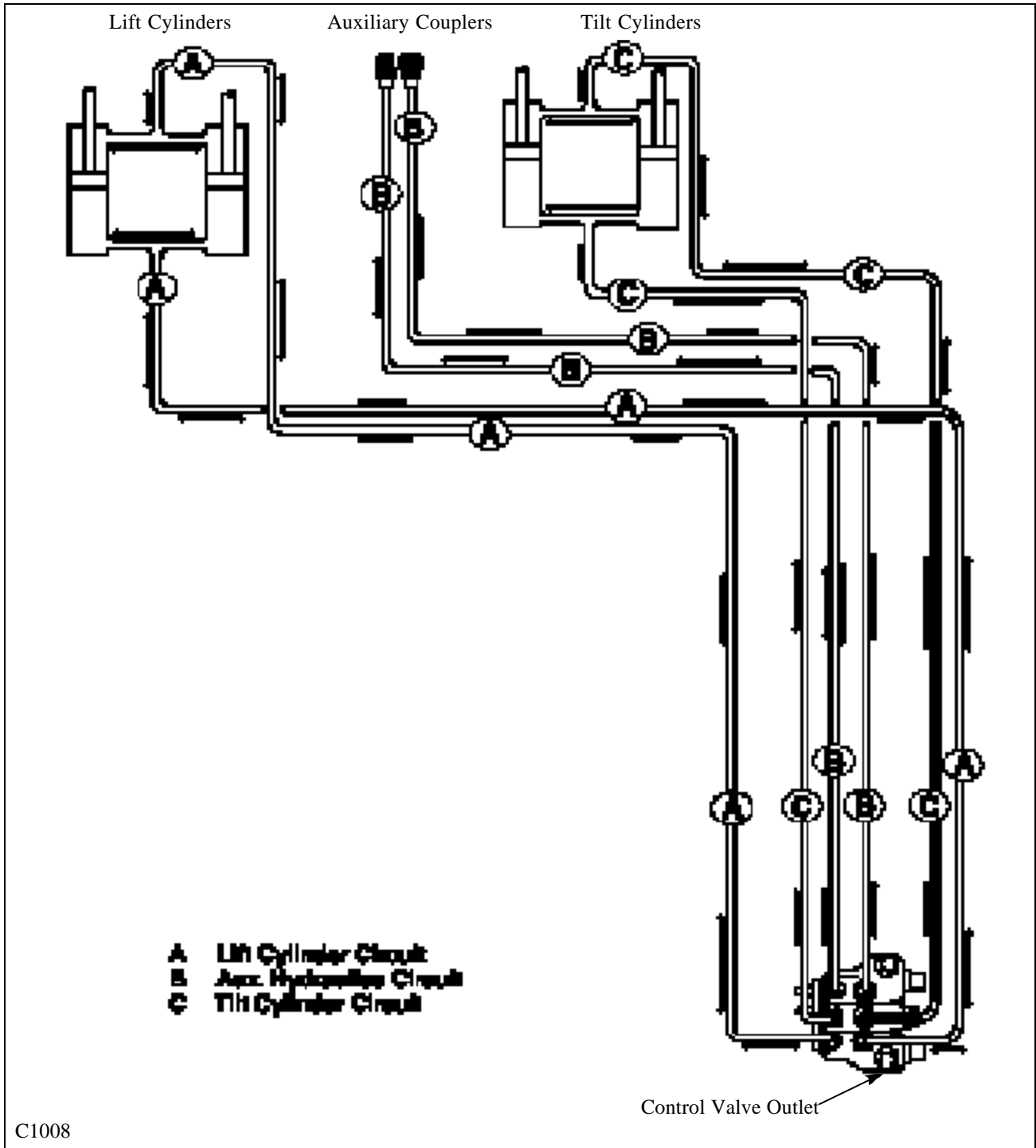

**NOTE:** Foot pedal control operated machine illustrated.

Hydraulic fluid comes out the port closest to the spool end of the valve when the spool is pushed in. Hydraulic fluid received at the fixed end of the cylinder pushes it out. When the hydraulic cylinder receives fluid at the ram (rod) end, it retracts.

# SPECIFICATIONS & MAINTENANCE 1.1



## Hydraulic Specifications

Pump Type	Gear, 0.61 cu. in. (11cc)
Pump Brand	Sauer Sundstrand
Pump Capacity (theoretical)	8.7 GPM (33 LPM)
Rated Speed	3000 RPM
Control Valve	Parallel Type
Main Relief Pressure, +/- 50PSI (3.5 Bar)	2150 PSI (148 Bar) @ Zero Flow
Reservoir Capacity	34 L (9 gallons)
Fluid Type	10W30 API SE / CD Oil
Reservoir Filtration	100 Micron
System Filtration	5 Micron
Lift Cylinders	(2) 2" Bore Diameter
Lift Cylinder Rods	1.125" Diameter
Tilt Cylinders	(2) 2" Bore Diameter
Tilt Cylinder Rods	1.125" Diameter
Lift Cycle +/- 1.5 seconds (Up / Down)	5.4 / 3.54
Tilt Cycle +/- 1.5 seconds (Up / Down)	2.35 / 3.06
Allowable Drop, Measured at the Cylinder Rod, Engine Off, @ Rated Capacity and Operating Temperature	1.5" (38mm) / 3 Minutes

Maintenance Schedule	First (HRS)	Every (HRS)
Oil level check	8	8
Oil filter change	50	150
General system check (leaks etc.)	8	8
Lubricate (grease pivots)	8	8
Reservoir filter change	1000	1000
Hydraulic oil change	1000	1000

# GENERAL INFORMATION 1.1

## 1

### Hydraulic System

Oil is drawn from the hydraulic oil reservoir through a 100 micron element. From there it travels to the main hydraulic pump. (fig. C2353).

The hydraulic pump is a gear type which is driven by a shaft and coupler through the hydrostatic drive pump at engine speed. The oil then flows from the gear pump to the hydraulic control valve. (fig. C2347).

The hydraulic control valve is equipped with an adjustable relief valve which is adjusted to 2150 PSI (148 Bar). The control valve is a parallel type with 3 spools (banks). The various spools activate the boom, bucket and auxiliary hydraulic functions.

When the spools are in neutral, oil flows from the hydraulic gear pump, through the control valve and returns to the 10 micron hydraulic filter. From the hydraulic filter, the fluid flows to charge the tandem hydrostatic pump and pressurize the hydraulic brake release system and then back to the hydraulic reservoir. Each control valve section spool end contains a centering spring which returns the spool to neutral when the foot pedal, or control handle, is released. (fig. C2350).

The boom section, on foot control operated loaders, has a detent mechanism to hold the spool in the float position. The auxiliary section is operated by foot pedal operation, or may have an optional electrical solenoid operated control, and may be engaged momentarily by the control lever mounted switch, forward or reverse, or by engaging the dash mounted toggle switch for constant power in the forward direction only.

The system relief valve operates whenever a hydraulic function has been restricted or over loaded. (fig. C2248). To protect against excessive pressure build up, the relief valve opens and allows oil to return to the return outlet. The system relief valve is adjustable, and is preset at 2150 PSI. (148 Bar)

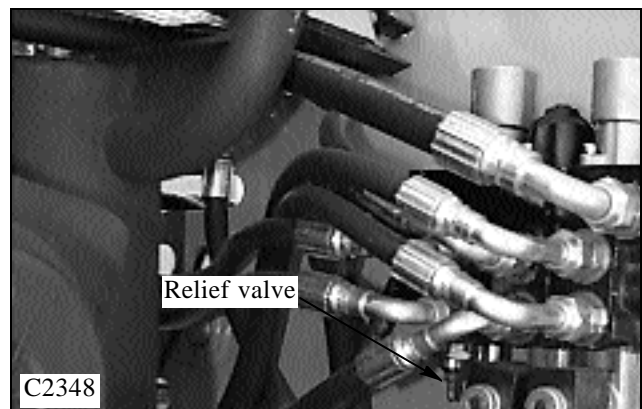
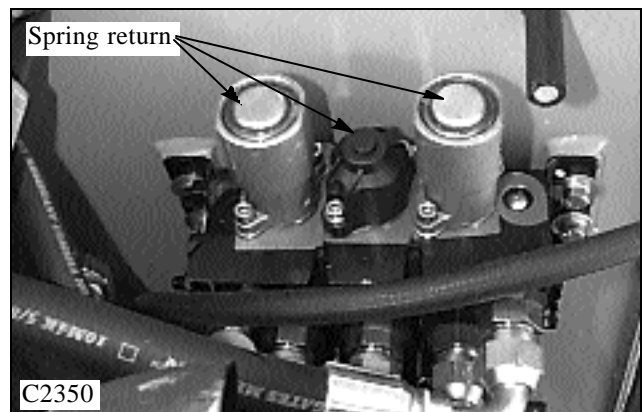
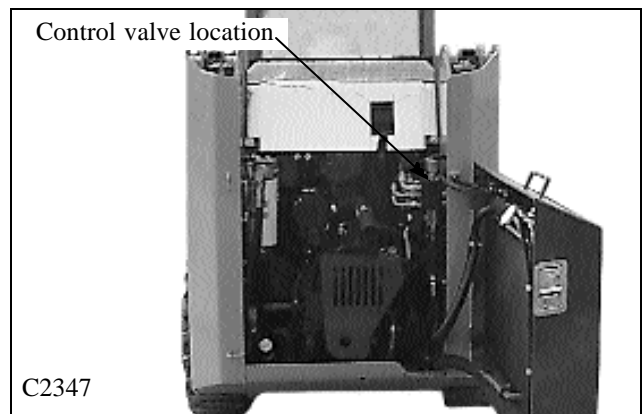
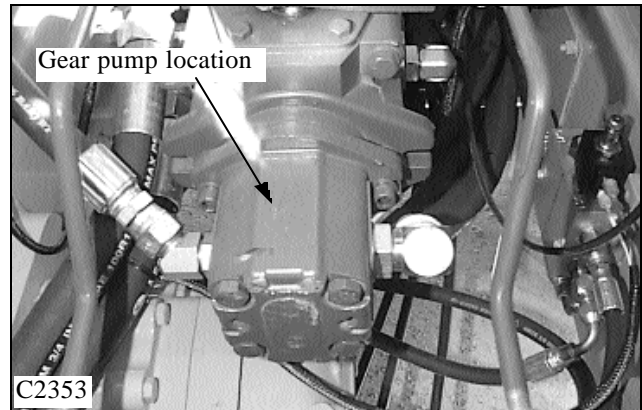

# GENERAL INFORMATION 1.1

1



# THOMAS

# GEAR PUMP 1.2

## 1

### Replacement

Start the gear pump removal procedure by removing any attachment, raising the boom arms and engaging the boom support pins. Shut off the engine.

#### WARNING

**To prevent personal injury, never work under the boom arms without the boom supports engaged.**

- 1 Remove the seat and hydrostatic shield. (fig. C2358, C2360)
- 2 Attach a vacuum system to the hydraulic oil reservoir filler location. Or drain the oil reservoir. Seal the threads on the drain plug, if removed, with teflon tape or a liquid form of pipe sealant before installing.
- 3 Disconnect the hydraulic hoses from the gear pump. (fig. C2353) Remove the pump fittings. Cap all open hoses to prevent contamination. After capping ends you may unhook vacuum system from oil reservoir.
- 4 Remove the 2 bolts holding the gear pump to the hydrostatic tandem section. (fig. C2353) Remove the gear pump. Check the seal. Replace if required.

#### IMPORTANT

**If gear pump replacement is being done because of failure, the hydraulic system and oil should be checked for contamination. See section 2.7.**

- 5 Replace gear pump in reverse order.
- 6 Start the engine and check for leaks. Do not use your hands to find leaks.
- 7 Check the fluid level in the hydraulic oil reservoir and replenish as required. (fig. C2354)
- 8 Follow the Start Up Procedure upon completing repairs. See next page.

#### WARNING

**Use caution when dealing with fluid under pressure. Escaping fluid under pressure can penetrate the skin and cause serious injury.**

#### IMPORTANT

**When making repairs to the hydraulic system, keep the work area and parts clean. Use caps and plugs on all open lines and ports. Follow the torque chart when tightening lines and fittings.**

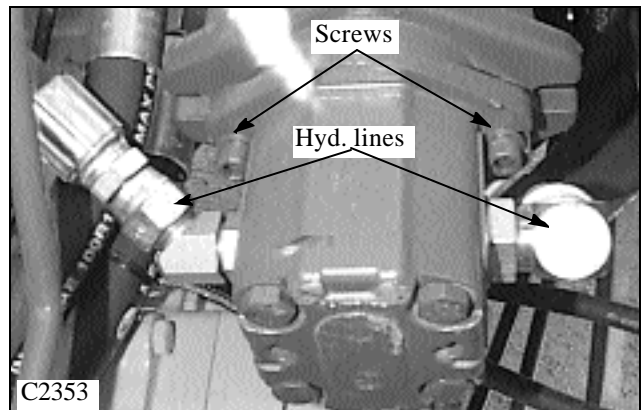
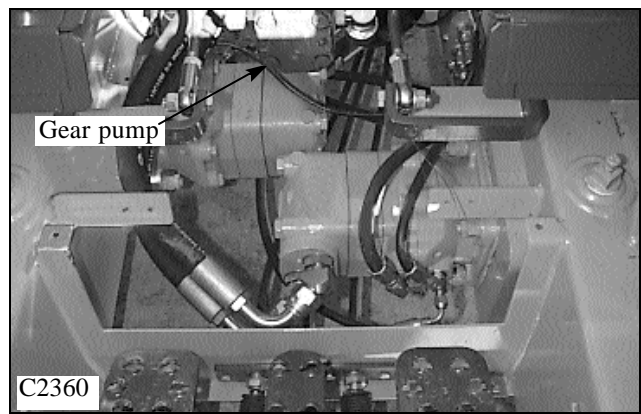
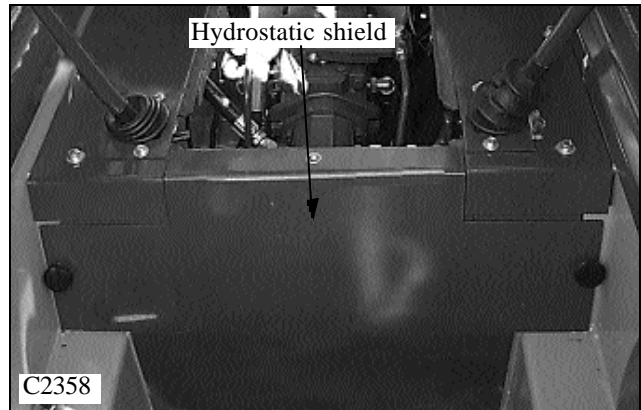

# GEAR PUMP 1.2

## Start up Procedure

- 1 Mount the gear pump to the loader. (fig. C2353)
- 2 Connect the hydraulic lines. Torque fittings and lines according to the torque chart section 1.8.
- 3 Start the pump and run for 3 minutes each @
  - a. Half speed at zero flow
  - b. Half speed, intermittently loaded to 500 psi (35 bar)
  - c. Full speed, intermittently loaded to 1000 psi (69 bar)
- 4 Check for leaks.
- 5 Check flow and pressure at rated speed as outlined in section 1.3.

### WARNING

Use caution when dealing with fluid under pressure. Escaping fluid under pressure can penetrate the skin and cause serious injury. Never use your hands to check for system leaks.

### IMPORTANT

Be sure the hydraulic oil reservoir is at the proper level before performing test.

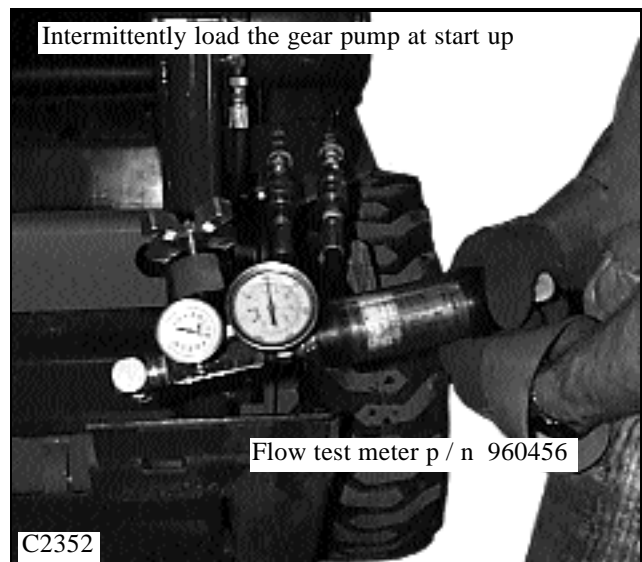
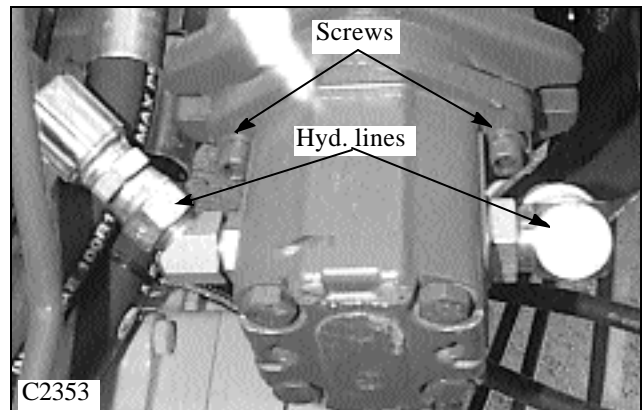

# CONTROL VALVE 1.3

## 1 Testing and Adjusting the Relief Valve Pressure

**NOTE: This test also checks the status of the gear pump capacities.**

Hoses and gauges required for this test must be capable of withstanding 3000 PSI (207 Bar) continuous pressure, and hydraulic flow meter capable of measuring 30 gallons per minute. (113 LPM)

1 The female coupler attached to the loader provides the power out when the auxiliary control is engaged. (fig. C2351) Connect the flow meter and pressure gauge inlet side to match the power out of the female auxiliary coupler to prevent meter and gauge damage. Be sure to connect a return line to the male auxiliary hydraulic quick coupler. Install the flow meter / pressure tester to the auxiliary hydraulic quick couplers. (fig. C2352)

2 Start the engine and engage the auxiliary hydraulic system. Increase the engine speed to full operating RPM. (See Section 7 for checking and adjusting engine speed to 3000 RPM plus or minus 25 RPM)

3 Turn the flow control valve on the flow meter to restrict the oil flow down to 2 GPM. (7.5 LPM) As you are turning the flow control valve, watch the pressure gauge and make sure it does not go over 3000 PSI.(207 Bar) Stop further adjustment immediately if the reading goes over this setting. Shut off the auxiliary hydraulic system and shut off the engine. Move to step 6 to make initial setting.

4 Repeat steps 2 and 3 if necessary. Allow the loader to operate at this setting until the oil temperature has increased to 160° F (71°C), operating temperature.

5 Turn the flow control valve further to restrict the oil flow to no flow. (Zero) Correct pressure setting is 2150 PSI +/- 100 PSI. (148 Bar, +/-6.9 Bar)

6 If adjustment is necessary, shut down the auxiliary hydraulic system, shut off the engine and return the flow control valve to the open position. Locate the control valve in the engine compartment.

7 Loosen the jam nut on the relief valve adjusting screw and turn the screw clockwise, counting the turns, until the screw bottoms out. (fig. C2348)

8 Turn the screw back out lesser turns than you turned in to increase pressure, or out more turns to decrease pressure.

9 Retake the pressure readings by performing steps 2 through 5. If necessary make further adjustments by repeating steps 6 through 9.

**NOTE: If inadequate pressure and / or flow is not available, the gear pump could be failing or the inlet to the gear pump is restricted.**

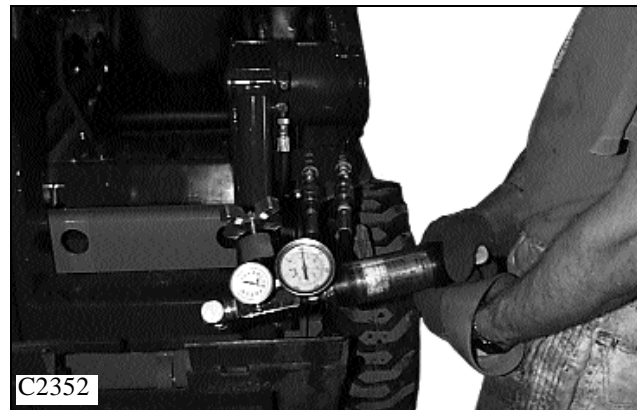
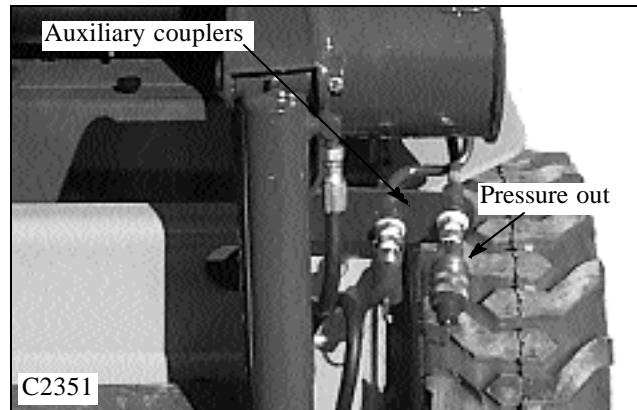

### CAUTION

Adjusting the relief valve setting too high may cause damage to the gear pump.

### WARNING

To prevent personal injury or damage to the loader, do not adjust the relief valve while the engine is operating.

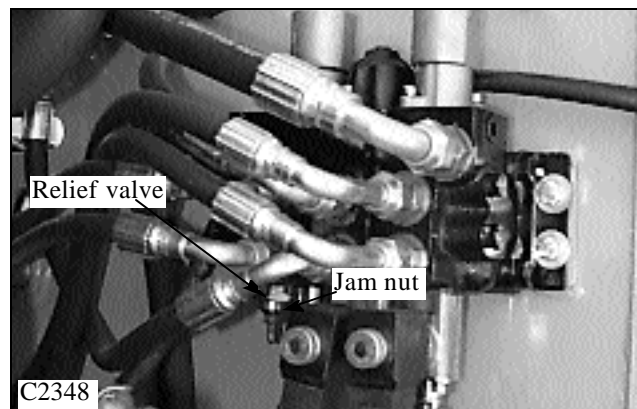



# CONTROL VALVE 1.3

## Control Valve Removal

1 Remove any attachment, lower the boom arms, engage the parking brake and shut off the engine

### IMPORTANT

Clean the work area prior to repair. Cap all open lines, fittings and ports to prevent contamination.

2 Disconnect the spool locks solenoid, and electrical auxiliary solenoid wiring connectors if equipped. (fig. C2348, C2349)

3 Disconnect the control cables. (fig. C2367)

4 Disconnect the return line from the control valve and remove the adapter fitting. Plug and cap all open ports and hose ends.

5 Disconnect the 6 hoses going to the boom, bucket and auxiliary circuits. Marking the hoses as you remove them is recommended for safety and to ease re-assembly and assure the circuits are functioning properly at restart.

6 Disconnect the the inlet hose coming from the gear pump. Cap the hose and fitting and remove the adapter fitting in the control valve.

7 Remove the 4 bolts holding the control valve to the mount and remove the control valve. (fig. C2350)

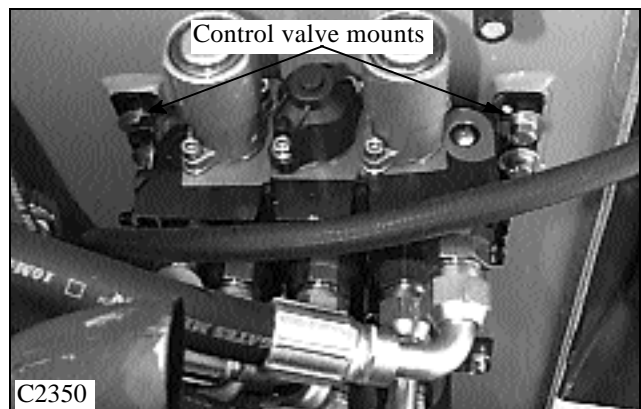
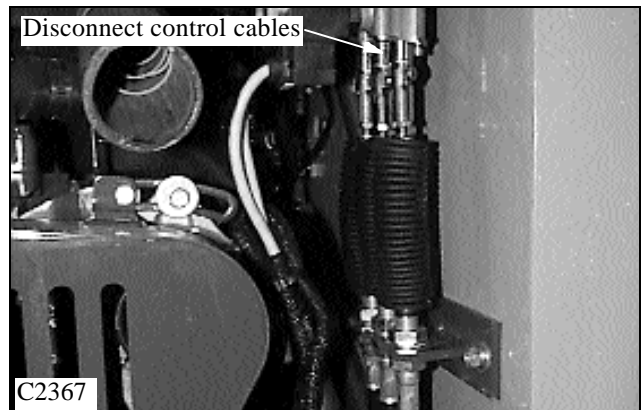
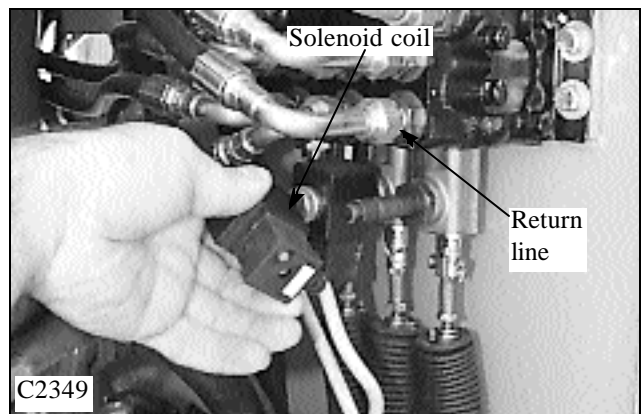
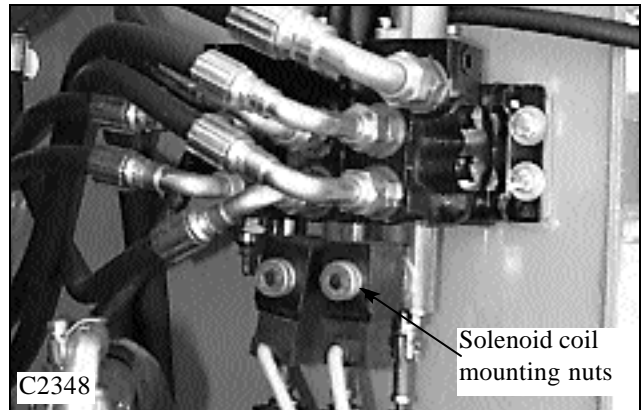

1

# CONTROL VALVE 1.3

## 1 Control Valve Installation

When installing a new control valve, always inspect the exterior for shipping or other damage, such as bent brackets, broken spring return caps or damaged spool lock mechanism. Repair all damaged parts before installation to the loader.

- 1 Mount the control valve to the loader. (fig. C2324a)

### IMPORTANT

Follow the hydraulic fitting torque chart in Section 1.10 when connecting fittings and lines.

- 2 Connect the control cables to the spools.
- 3 Connect the various hydraulic lines to their proper ports. (fig. C2324b).

### WARNING

Use extreme caution when checking the hydraulic system for leaks. Fluid under pressure can penetrate the skin and cause serious injury.

- 4 Connect the solenoid coils to the control valve locks. Apply a drop of Loctite 242 (blue) to the knurled retaining nut.

### WARNING

All safety switches must be connected and functioning to prevent possible operator injury.

- 5 Verify fluid level in the hydraulic oil reservoir. (fig. C2354). Top off as required to bring oil level to approximately half way in the site gauge.

### WARNING

Verify the relief valve pressure setting after replacing or servicing the control valve.

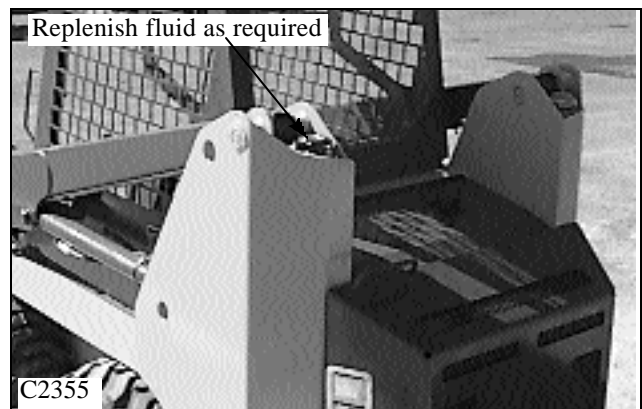
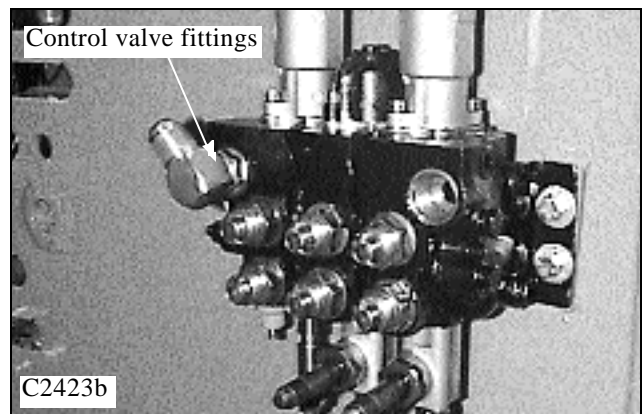
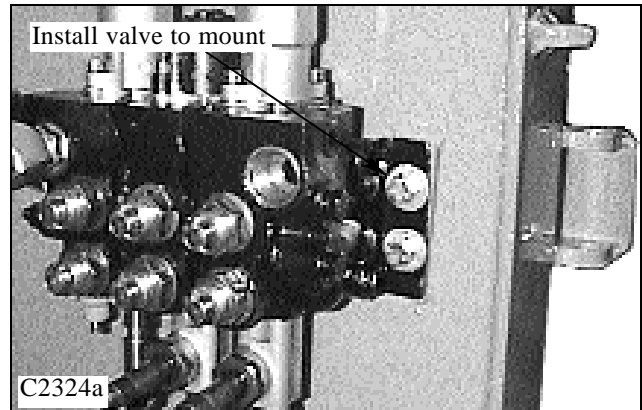



# THOMAS

# CONTROL VALVE 1.3

1

Salami Model to S / N LC001080

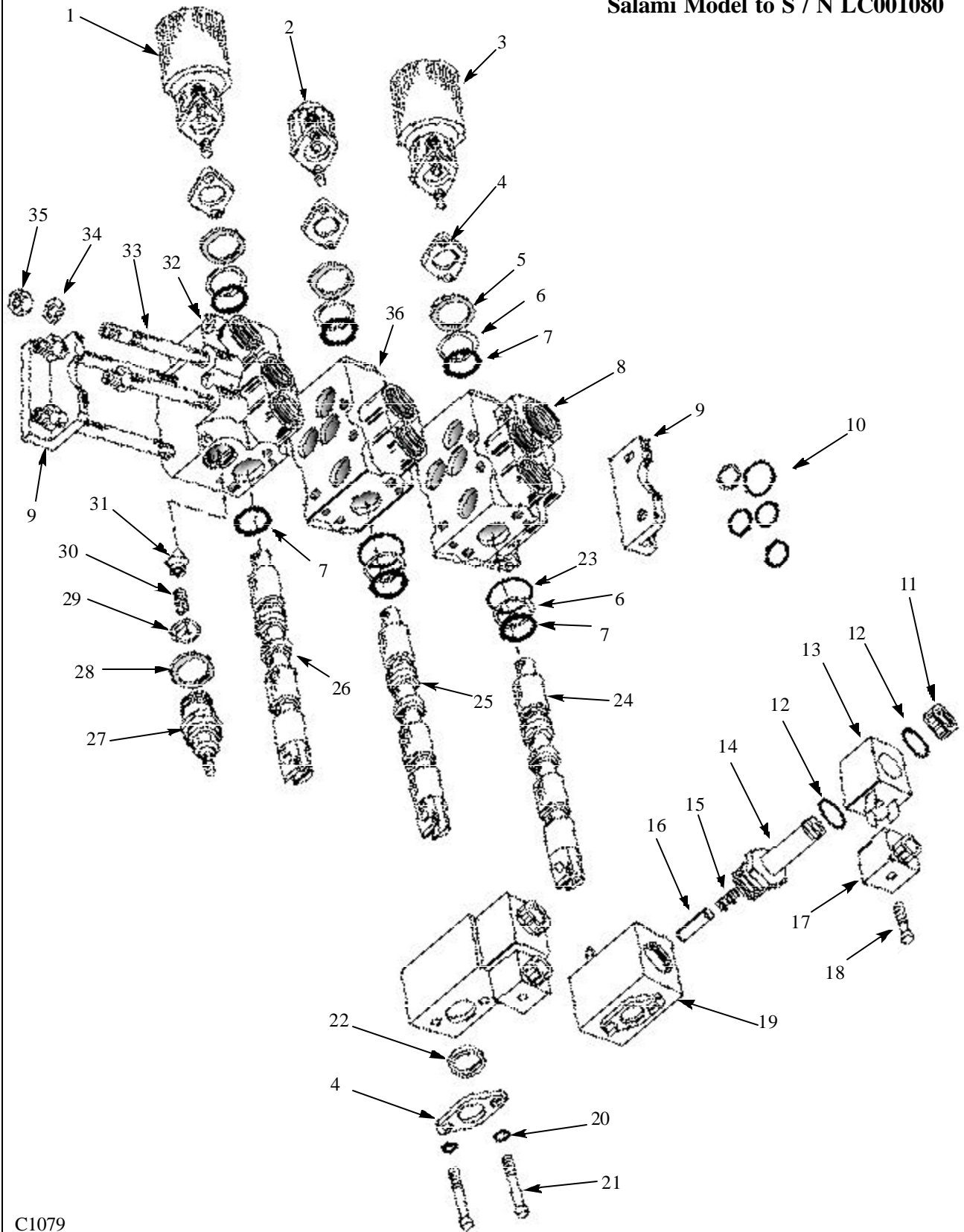

C1079

# CONTROL VALVE 1.3a



## Diagram C1079 Legend

- 1 Auxiliary spool spring return
- 2 Tilt spool spring return
- 3 Lift spool spring return
- 4 Plate
- 5 Washer
- 6 Seal shim
- 7 Seal
- 8 Outlet / lift section body
- 9 Mounting bracket
- 10 Section seals
- 11 Knurled nut
- 12 Seal
- 13 Solenoid coil
- 14 Spool lock solenoid post
- 15 Spring
- 16 Lock pin
- 17 Electrical connector
- 18 Screw
- 19 Spool lock body
- 20 Lock washer
- 21 Screw
- 22 Scraper seal
- 23 Seal
- 24 Lift spool
- 25 Tilt spool
- 26 Auxiliary spool
- 27 Relief valve body
- 28 Washer seal
- 29 Spring washer
- 30 Spring
- 31 Poppet valve
- 32 Inlet / auxiliary section body
- 33 Tie bolt
- 34 Flat washer
- 35 Nut
- 36 Tilt section body

# CONTROL VALVE 1.3

## 1

### Disassembly / Repair

Remove the hydraulic control valve as outlined in the removal section, page 1-7. Ensure all openings are plugged to prevent solvents and dirt from contaminating the control valve assembly. Before disassembling the hydraulic control valve, clean the body with a suitable solvent and dry with compressed air.

#### WARNING

To avoid eye injury, use safety goggles when cleaning with compressed air.

Refer to diagram C1079, pg. 1-11, to assist in the disassembly of the control valve.

- 1 Remove the solenoid coils and O-ring seals. (fig. C2368).
- 2 Remove the locking pin assembly from the adapter block. (fig. C2369)
- 3 Remove the pressure relief valve. (fig. C2370) Tip the valve down slightly to ensure the valve poppet comes out with the spring.

**Note: Figure C2371 shows an exploded view of the relief valve system.**

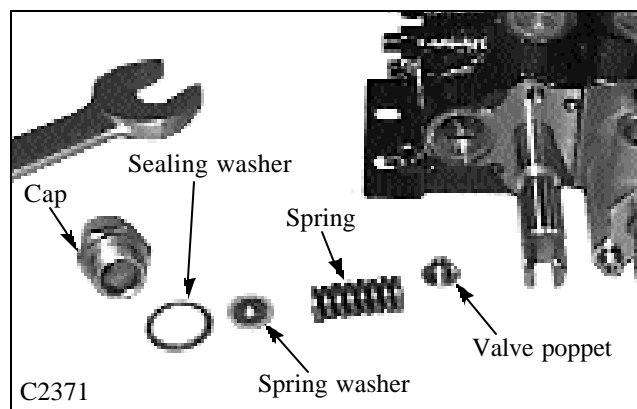
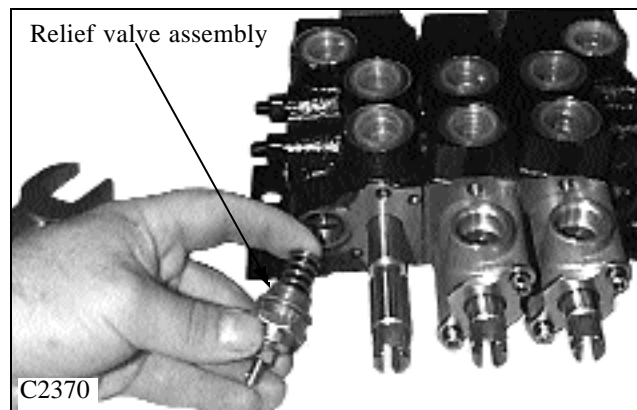
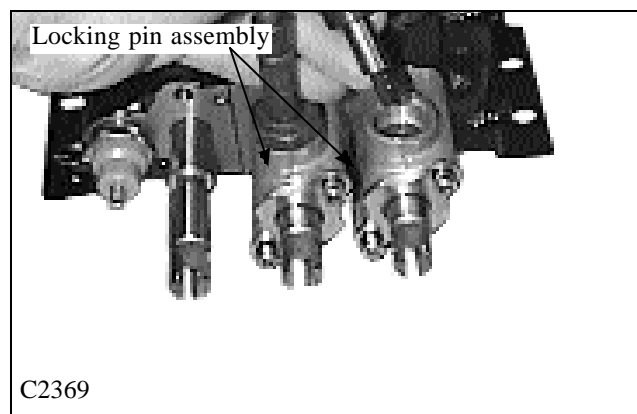
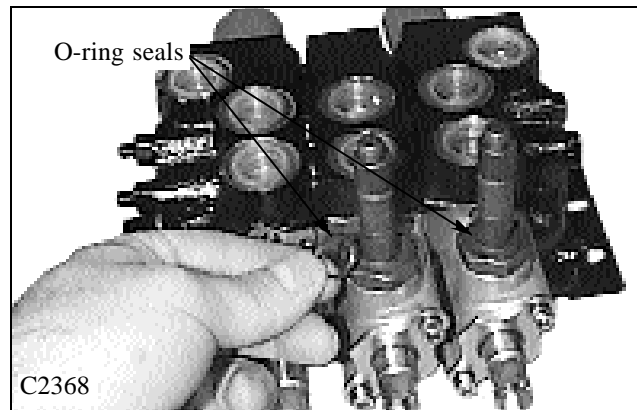

# CONTROL VALVE 1.3

1

## Disassembly / Repair (cont'd)

4 Remove the screws retaining the lock adapters to the control valve assembly. (fig. C2372).

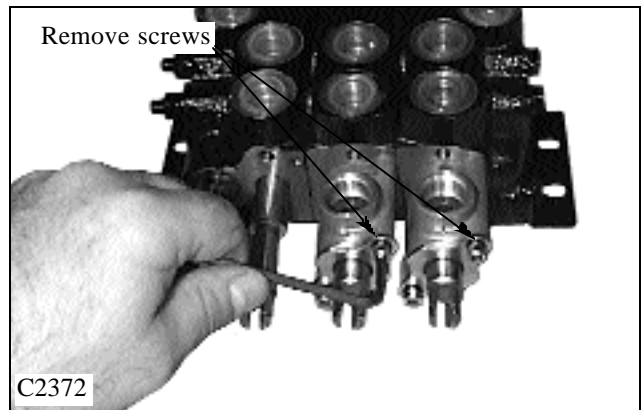

5 Remove the plate and adapter from the control valve and spool. (fig. C2373, C2374)

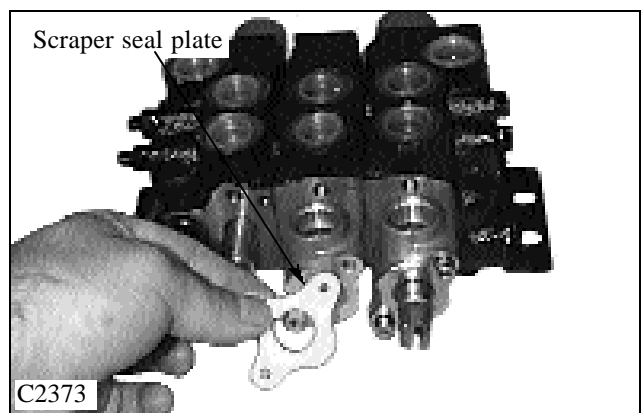

6 Remove the O-ring seals and seal shim. (fig. C2374). Discard the seals and replace with new.

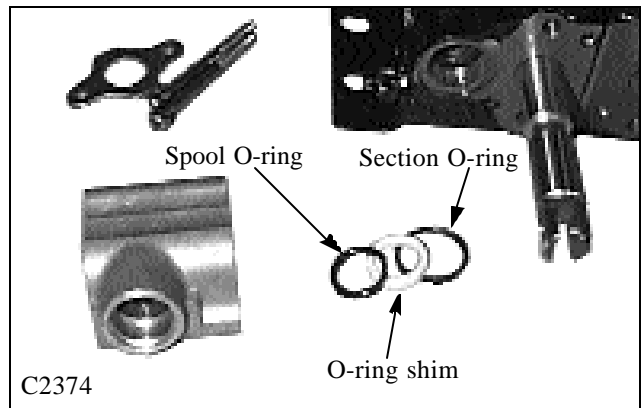

7 Clean the lock adapter with solvent and inspect the inside of the lock adapter for excessive wear such as gouging or chipping. Replace with new if worn.

8 Lubricate a new spool O-ring with system oil and install to the lock adapter. (fig. C2375)

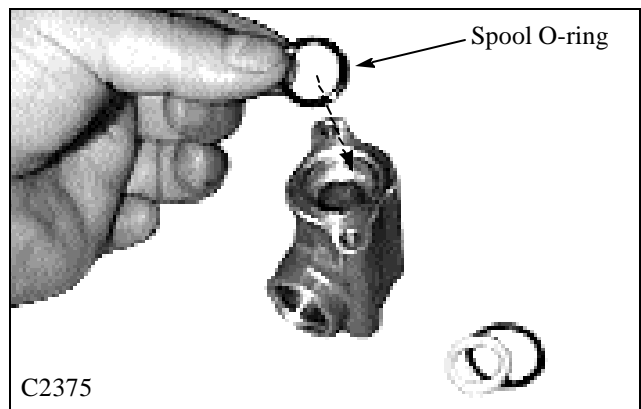

# CONTROL VALVE 1.3

# 1

## Disassembly / Repair (cont'd)

9 Lubricate the spool O-ring shim with system oil and install over spool seal. (fig. C2376).

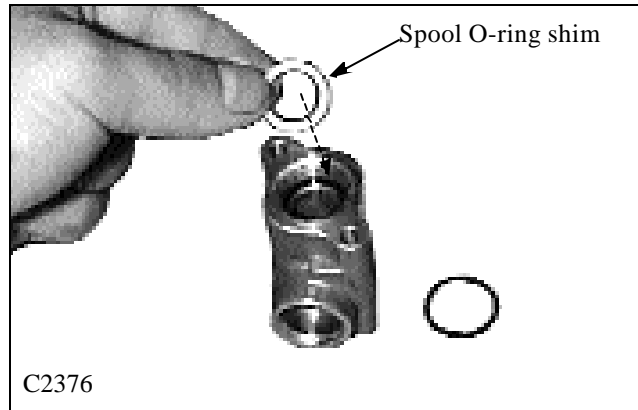

10 Lubricate the section O-ring seal with system oil and install to the lock adapter assembly. (fig. C2377).

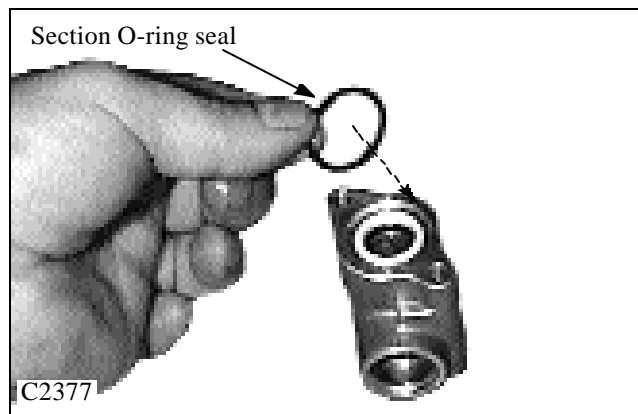

11 Figure C2378 shows the completely resealed lock adapter assembly ready to be installed to the control valve assembly.

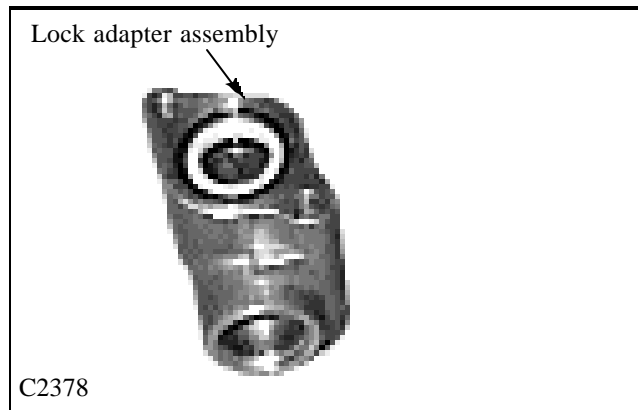

12 Remove the screws retaining the spring return caps to the control valve assembly. (fig. C2379). Remove the spring return assemblies.

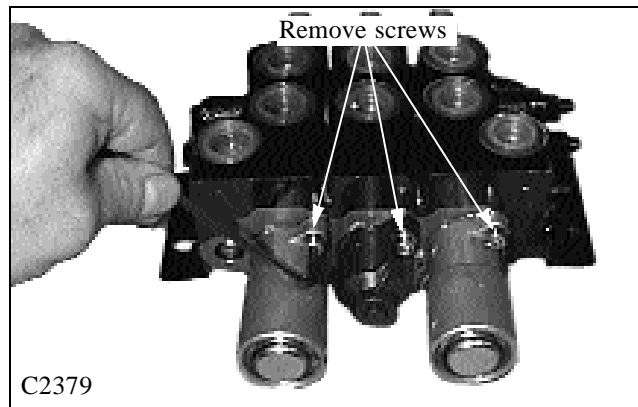



# CONTROL VALVE 1.3

1

## Disassembly Repair (cont'd)

13 **Note:** The plastic cap over the tilt spring has flat washers to distribute the load of the mounting screws to prevent cap damage. (fig. C2380). Be sure to install the flat washers when reassembling to the control valve.

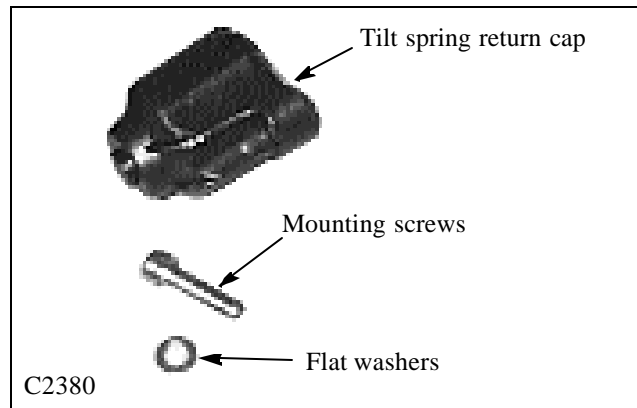

14 Figure C2381 shows spring assemblies and detent mechanisms as viewed with the caps removed.

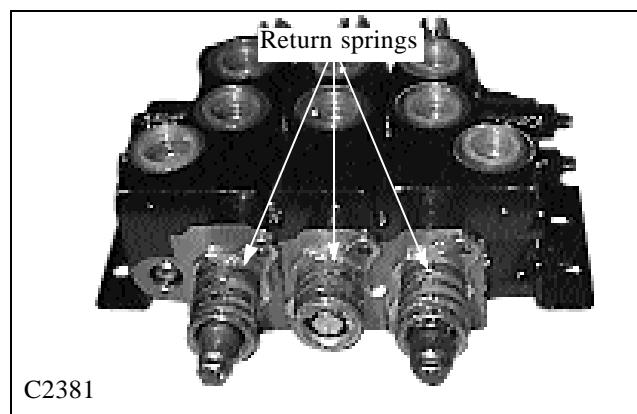

15 Remove the section spools noting their location to the appropriate bores. (fig. C2382). Do not replace the spools in any other spool bores than the one it came out of. Clean the spools and valve sections with solvent and inspect for gouging or chipping. Replace sections as required. Minor scratches on the spool may be removed with fine emery cloth. Be sure to remove all solvent from the control valve body if no further disassembling of the control valve is to be performed.

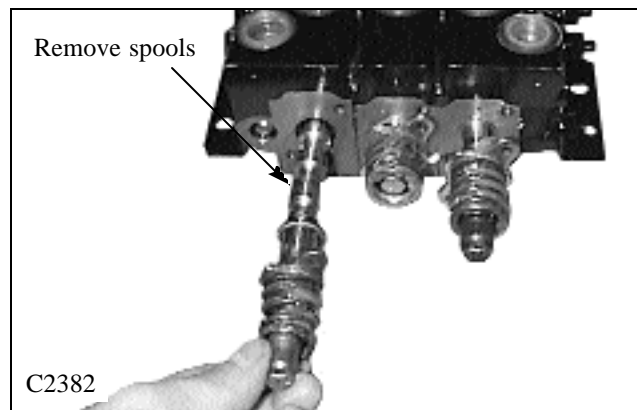

16 Install new O-ring seals at time of assembly. (fig. C2383) Lubricate the seal, bore and spool with system oil when reassembling the components.

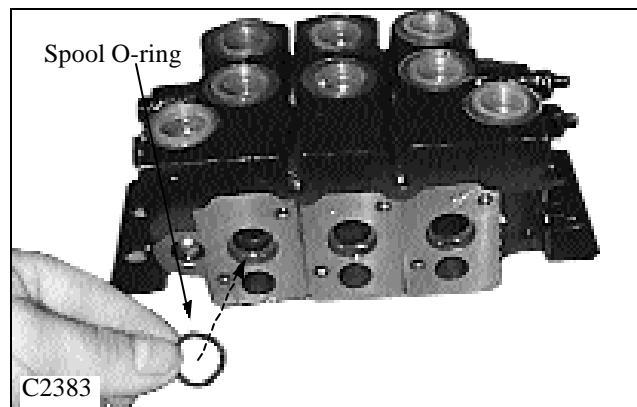

# CONTROL VALVE 1.3

# 1

## Disassembly / Repair (cont'd)

17 Install the O-ring spacer shim to the spool O-ring seal. (fig. C2384).

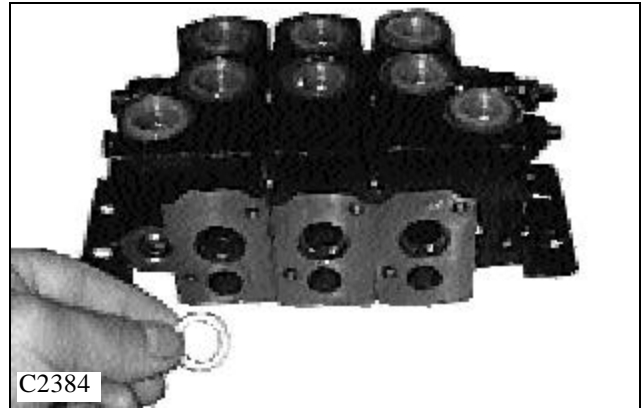

18 Install the flat washer over the O-ring spacer. (fig. C2385) The spring return side of the control valve is now complete.

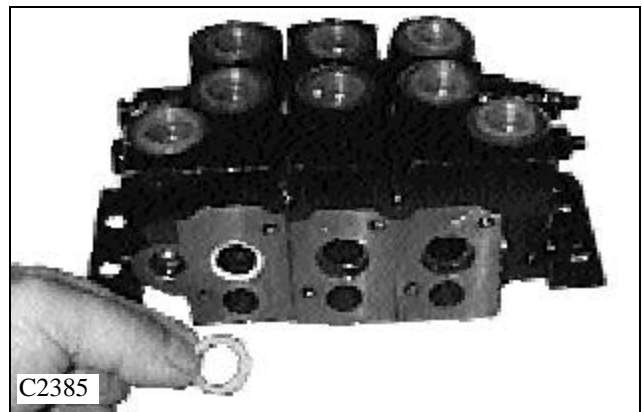

19 The auxiliary section, section without lock adapter, has an O-ring seal located in a machined groove in the section housing. (fig. C2386) Remove the seal using a pick tool and replace with new. Lubricate the O-ring with system oil. Figure C2387 shows the seal installed.

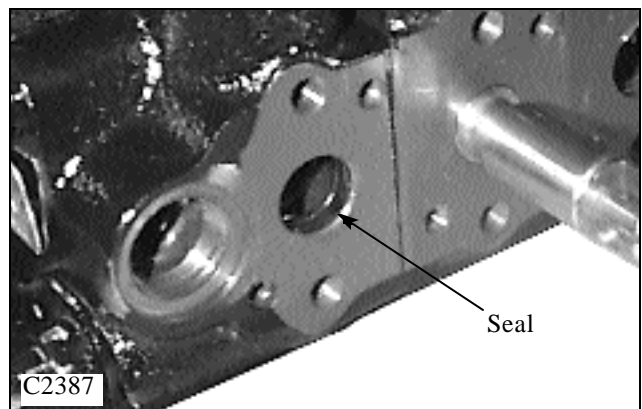
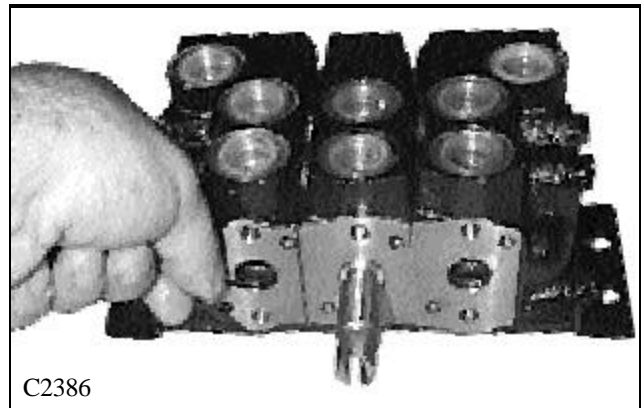

# CONTROL VALVE 1.3

1

## Disassembly / Repair (cont'd)

20 Section seals may be replaced without removing spools and spring return mechanisms. Loosen the bolts retaining the control valve sections together. (fig. C2388). Upon assembly follow the torque specifications given Section 8.

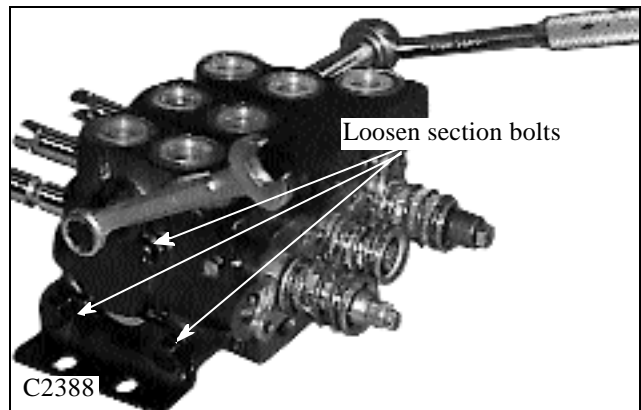

21 Note the flat spacer washers used on the upper bolts. (fig. C2389)

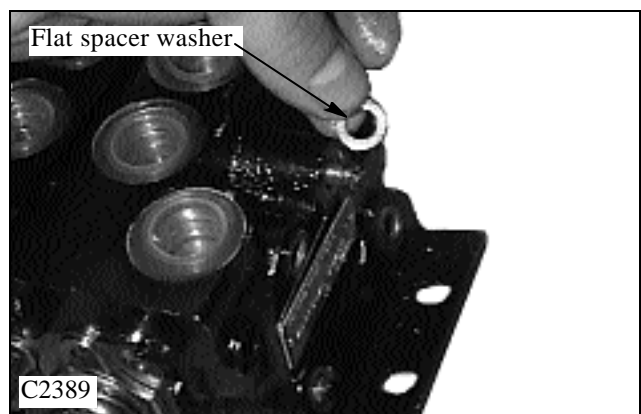

22 Remove the bolts and mounting brackets. (fig. C2390)

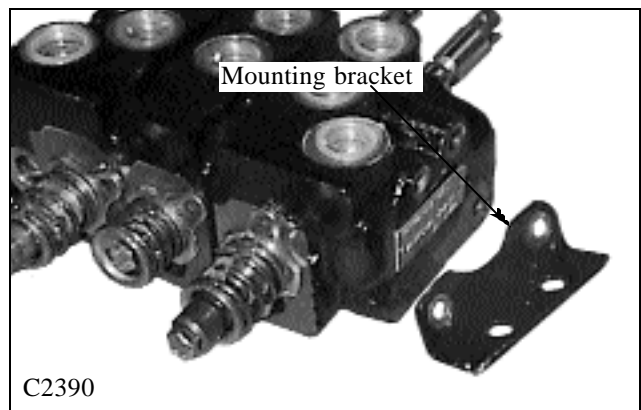

23 Separate the control valve sections. (fig. C2391)

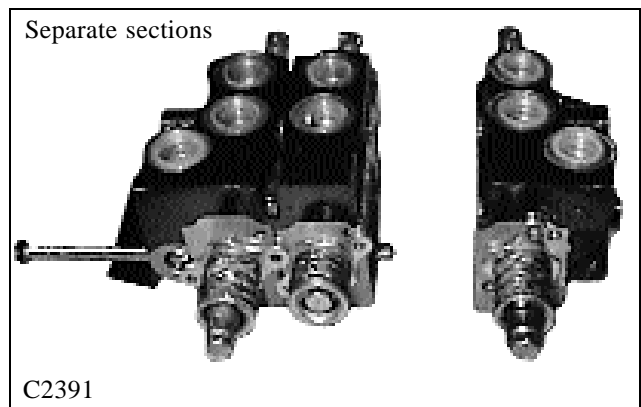

# CONTROL VALVE 1.3

## 1

### Disassembly / Repair (cont'd)

24 Remove and discard the O-ring seals between the sections. Replace with new. Be sure to replace the O-ring seal spacer shim upon assembly. (fig. C2392, C2393). Lubricate the seals with system oil upon assembly. When reassembling the control valve sections, follow the torque specifications in Section 8.

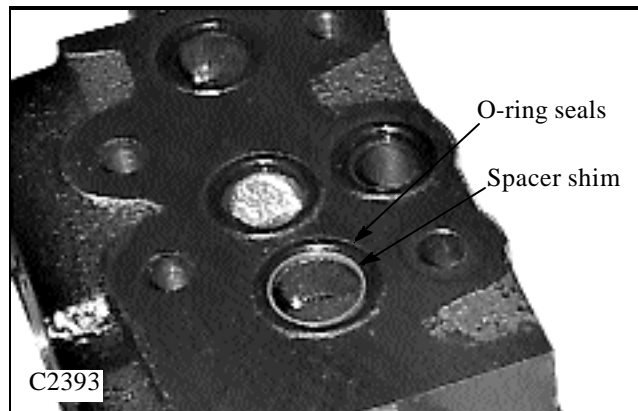
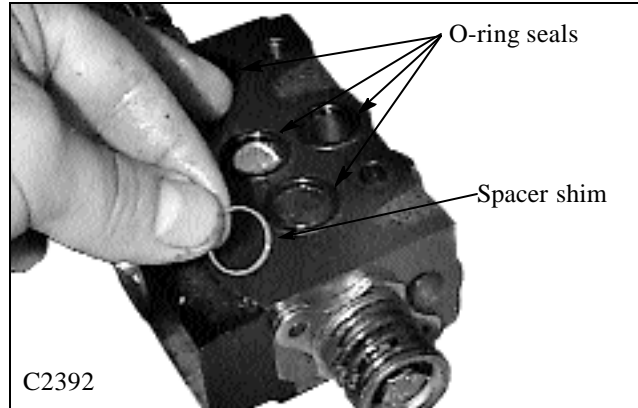

25 To remove the detent mechanism and spring from the spool, place an allen wrench or screwdriver blade through the spool eyelet to hold the spool from turning while removing the spring and detent mechanism. (fig. C2394).

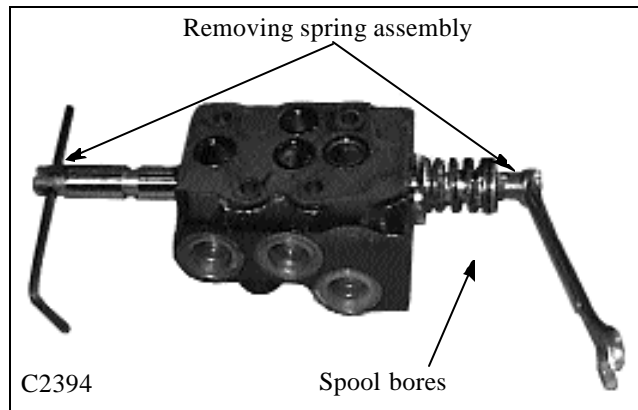

26 Remove the mechanism and arrange the parts in order of placement. (fig. C2395) Inspect the detent part and bushings for burrs and wear. Replace if worn.

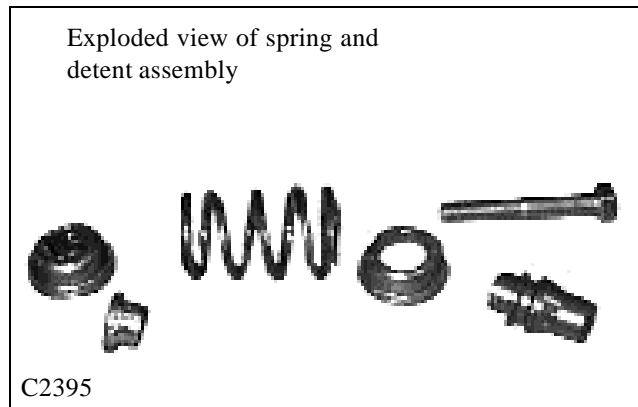

# CONTROL VALVE 1.3

1

## Disassembly / Repair (cont'd)

27 Replace the spring and detent mechanism in the reverse order. (fig. C2396). Install spring bushing. Lubricate the spring bushings with Castrol Spheerol grease or equivalent.

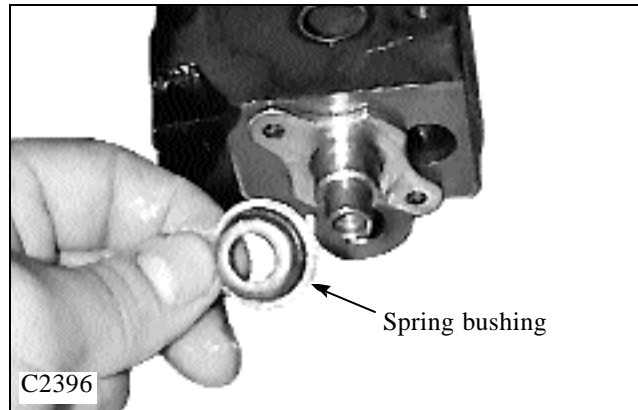

28 Install sleeve bushing. (fig. C2397). Lubricate the bushing with Castrol Spheerol grease or equivalent.

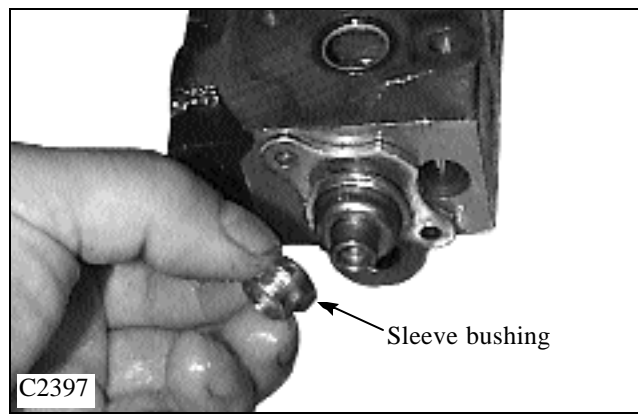

29 Install the spring, spring bushing and detent. (fig. C2398) Install the bolt. Apply Loctite 242 (blue) to the threads and tighten to specifications given in Section 8.

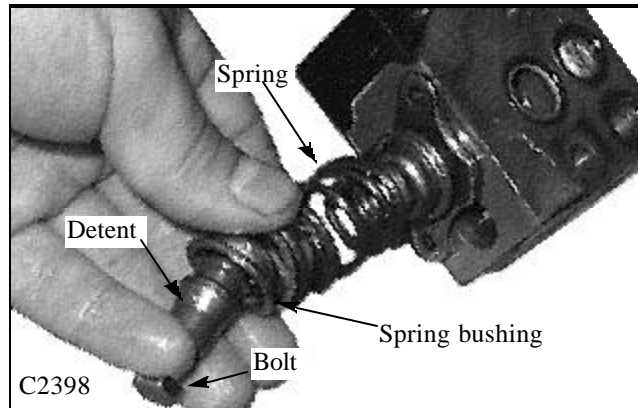

30 To service the spring return mechanism in the cover, remove the circlip retaining the cover. (fig. C2404).

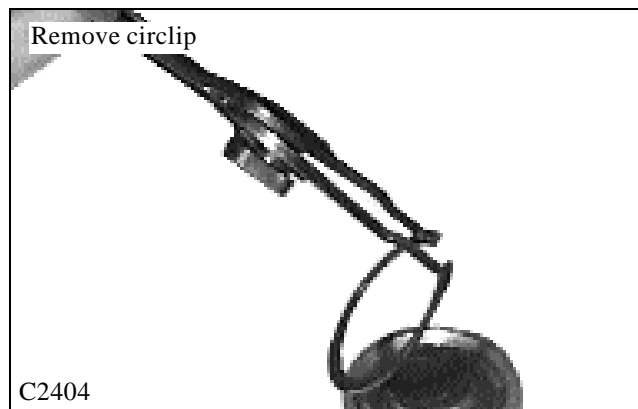

# CONTROL VALVE 1.3

1

## Disassembly / Repair (cont'd)

31 Remove the cover. (fig. C2405).

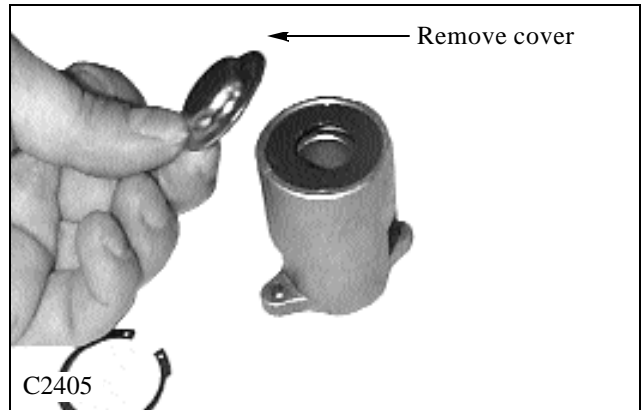

32 Remove the spring washer. (fig. C2406).



33 Remove the spring. (fig. C2407). Inspect the spring for broken or sacked coils. Replace the detent spring return with a new kit if spring damage is apparent.

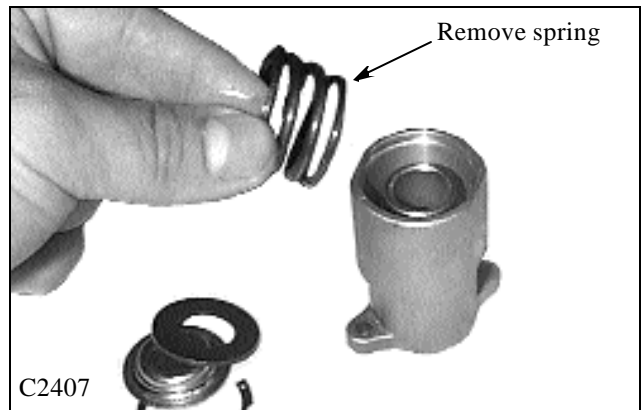

34 Remove the detent ball sleeve and cup. (fig. C2408).



# CONTROL VALVE 1.3

1

## Disassembly / Repair (cont'd)

35 Separate the sleeve and cup assembly. (fig. C2409).  
Inspect the tapered cup, balls and sleeve for wear.  
Replace with new detent kit assembly if wear is evident.

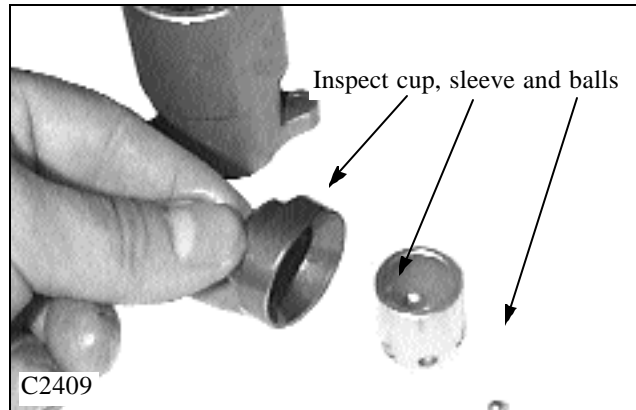

36 Remove the spring washer. (fig. C2410).



37 Clean all parts with solvent. Lubricate all parts with Castrol Spherol grease or equivalent.

38 Replace the greased detent balls to the cup and sleeve (fig. C2411) and reassemble the complete spring return mechanism in the reverse order above.

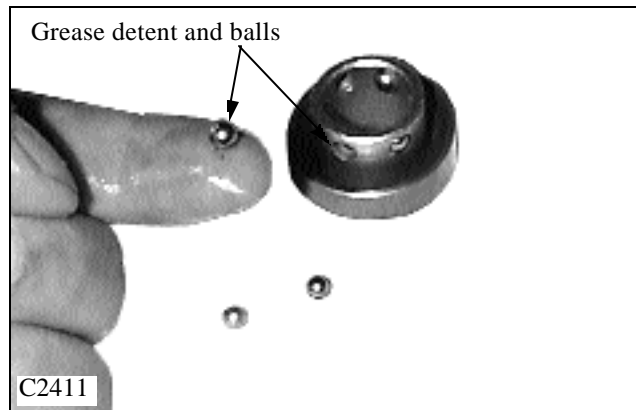

39 The grease holds the detent balls in position during assembly to the control valve and spool. (fig. C2412)

40 Replace the cap assembly to the control valve and tighten the screws evenly.

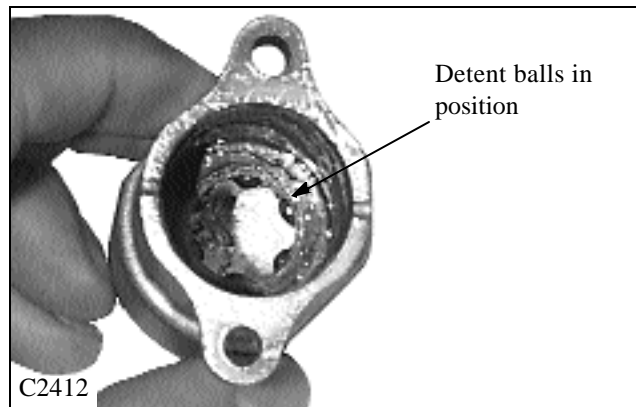

### IMPORTANT

Check to make sure the detent balls are in position before assembling to the control valve to assure proper function of the control spool and detent mechanism.

1



THOMAS



# CONTROL VALVE 1.3

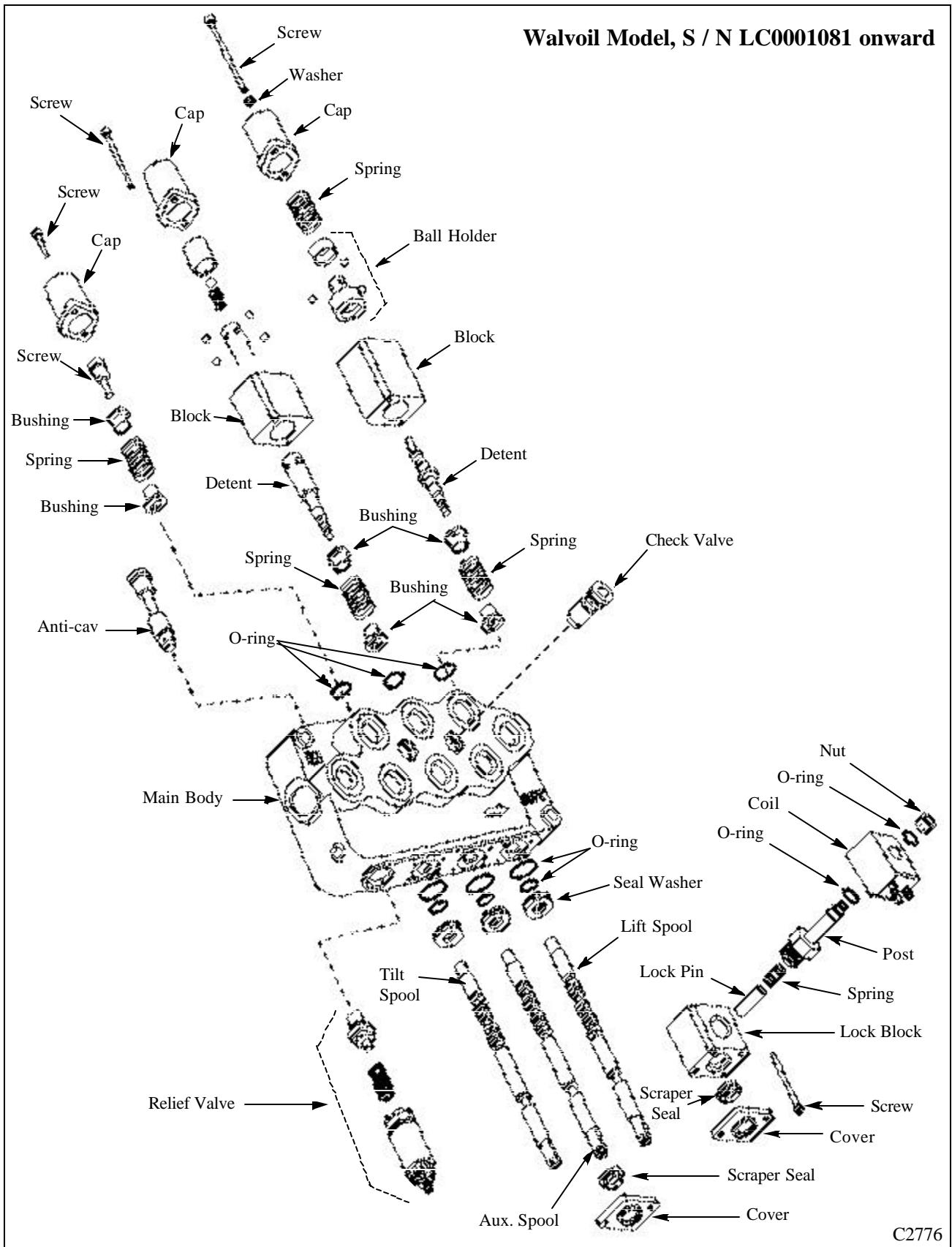

# CONTROL VALVE 1.3

# 1

## Disassembly / Repair

Before disassembling the hydraulic control valve, clean the body with a suitable solvent and dry with compressed air.

### WARNING

To avoid eye injury, use safety goggles when cleaning with compressed air.

Ensure all openings are plugged to prevent solvents and dirt from contaminating the control valve assembly. Refer to diagram C2776, pg. 1-25, to assist in the disassembly of the control valve.

1 Remove the pressure relief valve. Discard the O-rings (fig. C2975).

2 Remove the solenoid coils and locking pin from the valve lock block. (fig. C2235, C2236) There are 2 O-ring seals located on either side of the solenoid coils.

3 Remove the outer wiper seal cover from the lock block. (fig. C2244)

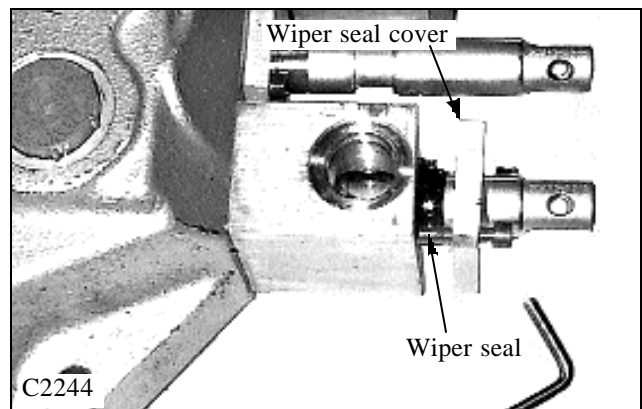
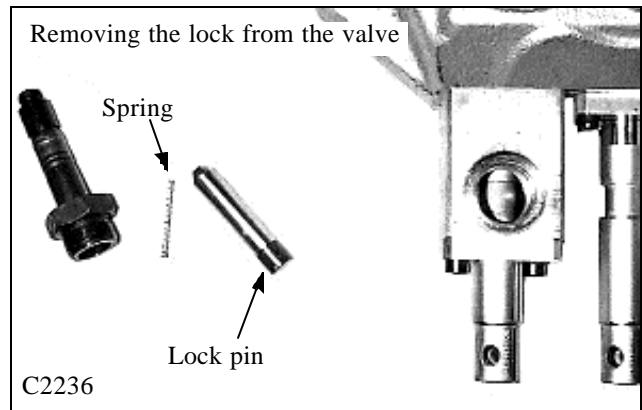
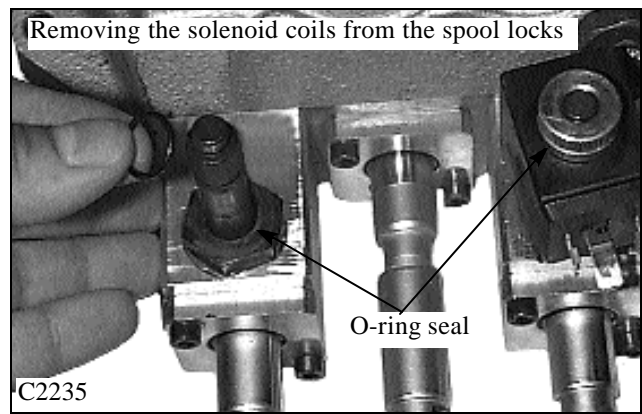
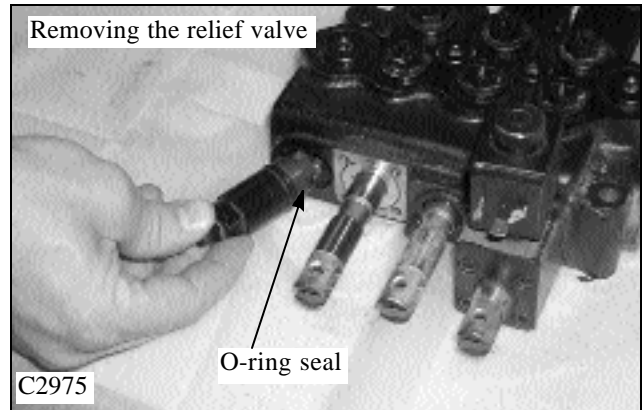

# CONTROL VALVE 1.3

1

## Disassembly / Repair (cont'd)

4 Remove the lock block from the valve. (fig. C2241)

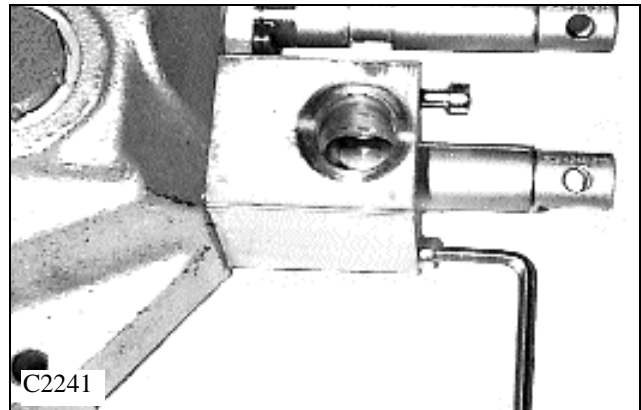

5 Remove the spring return / centering cap from the end of the spool. (fig. C2237)

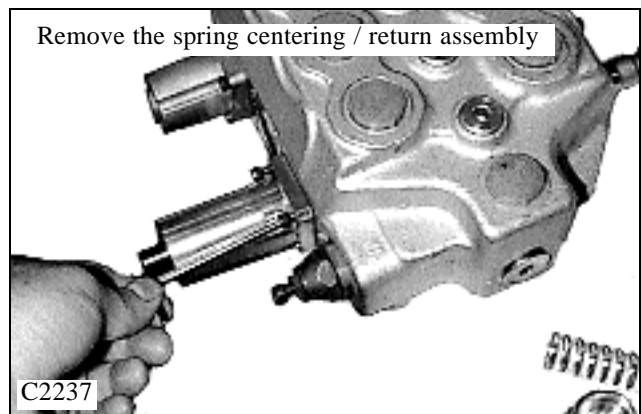

6 Pull out the spool. (fig. C2240) As you pull out the spool, note it's smooth action as it comes out of the valve body. The spool should move freely and smoothly in the bore of the valve body. Check the control valve spool and bore for scuff marks or abnormal wear. Replace the spool and or control valve if signs of wear are present.

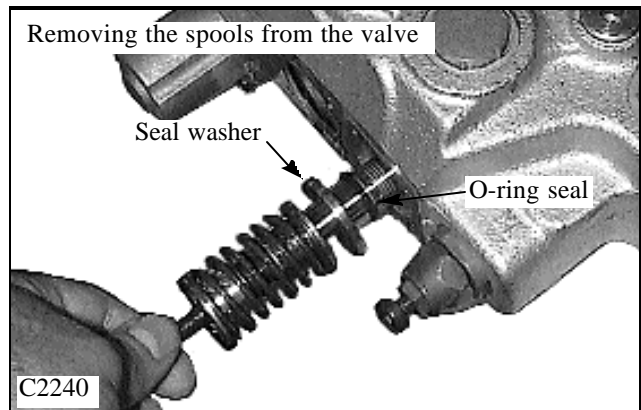

7 Remove the check valves from control valve body. (fig. C2239) They are located between the ports of each section. Check the seat and poppet of the valve body and check valve. Replace the check valve and or the control valve if any signs of wear are present.

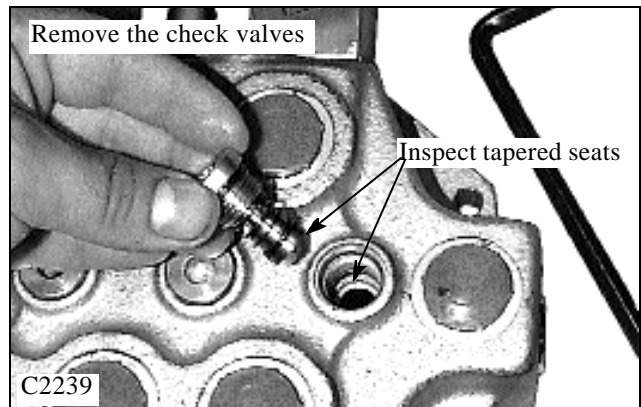

# CONTROL VALVE 1.3

# 1

## Disassembly Repair (cont'd)

8 When replacing the spool to the control valve, use new O-ring seals and apply system oil to the O-rings and spools. (fig. C2251).

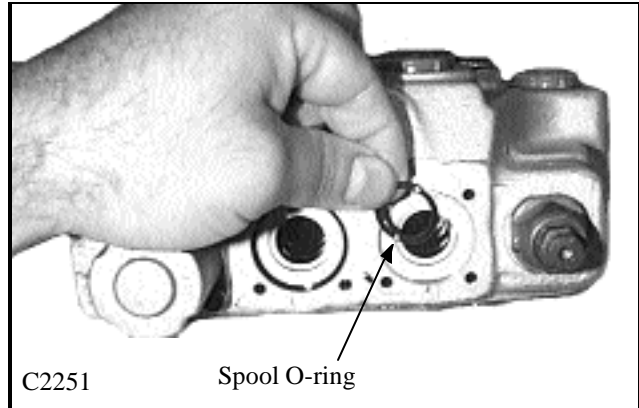

9 Fit the seal washer to the control valve with the beveled side of the washer facing the control valve. (fig. C2252) Fit the spool to the control valve now if repairs are not needed to the detent or spring return mechanism. Use system oil to lubricate the spool before inserting to the control valve.

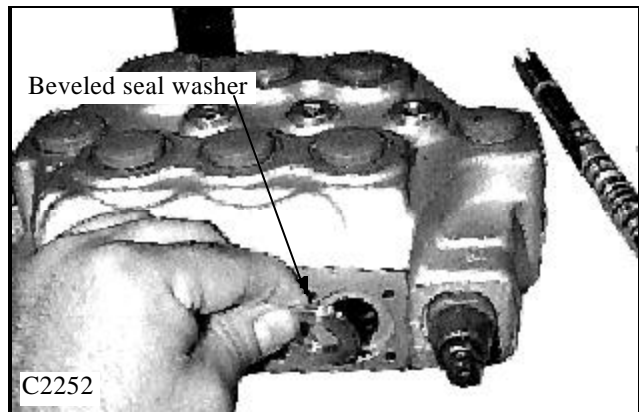

10 Photographs C2238, C2242 are exploded views of the lift spool detent mechanism. Place the cable end of the spool in a vice, or insert a screw driver through the clevis pin holes, to keep it from turning. The detent is threaded to the spool and can be removed for inspection or repairs.

Replace broken springs, worn detents and / or damaged detent balls with a new detent kit.

Apply Loctite 542 to the threads of the detent when installing to the spool.

Apply Castrol "Spheerol" TN grease to the inside of the spring cover.

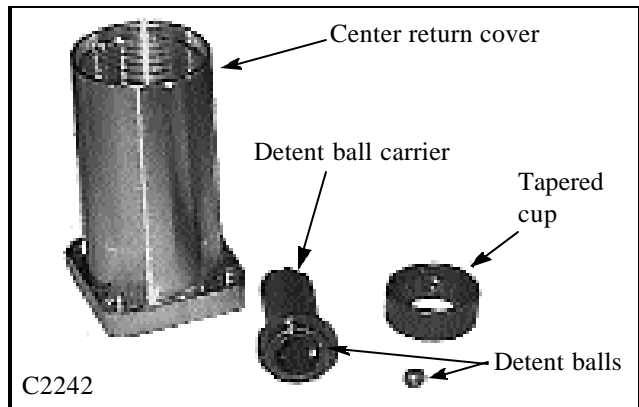
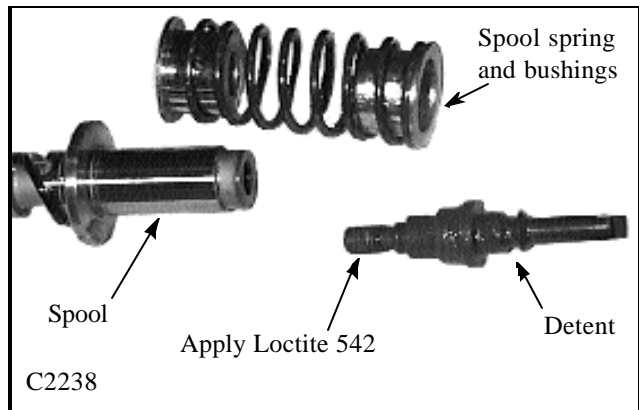

# CONTROL VALVE 1.3

## Disassembly / Repair (cont'd)

11 When installing the detent to the control valve spool, apply Loctite type 252 to the threads. Tighten the detent to the spool at 24 Nm (17.7 lbs / ft).

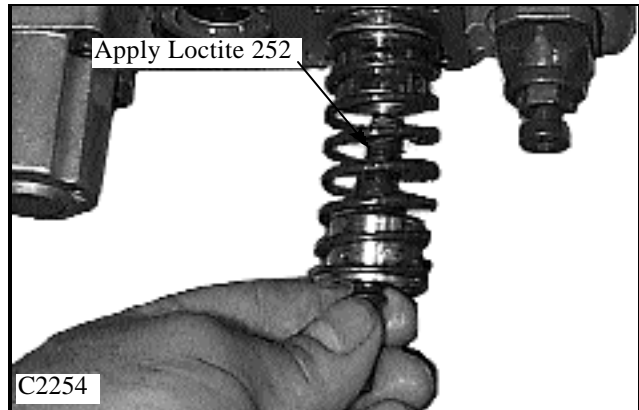

12 Install the spring return / centering cover and tighten the mounting screws evenly to 6.6 Nm (4.9 lbs / ft). Install the end cap to the cover and tighten to 9.8 Nm (7.2 lbs / ft).

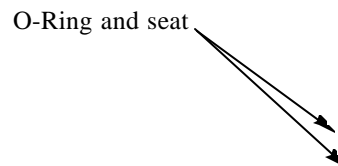
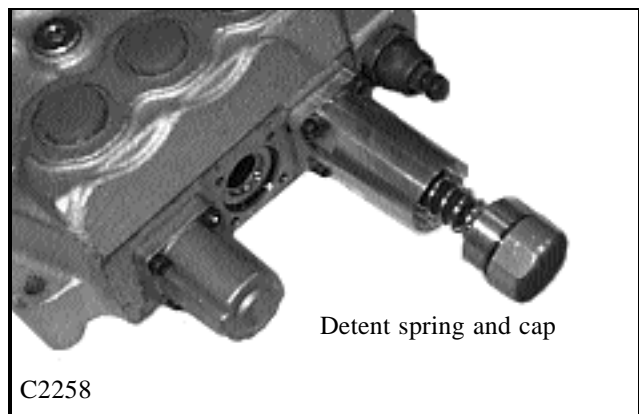

C2250

1

# HYDRAULIC CYLINDERS 1.4

1

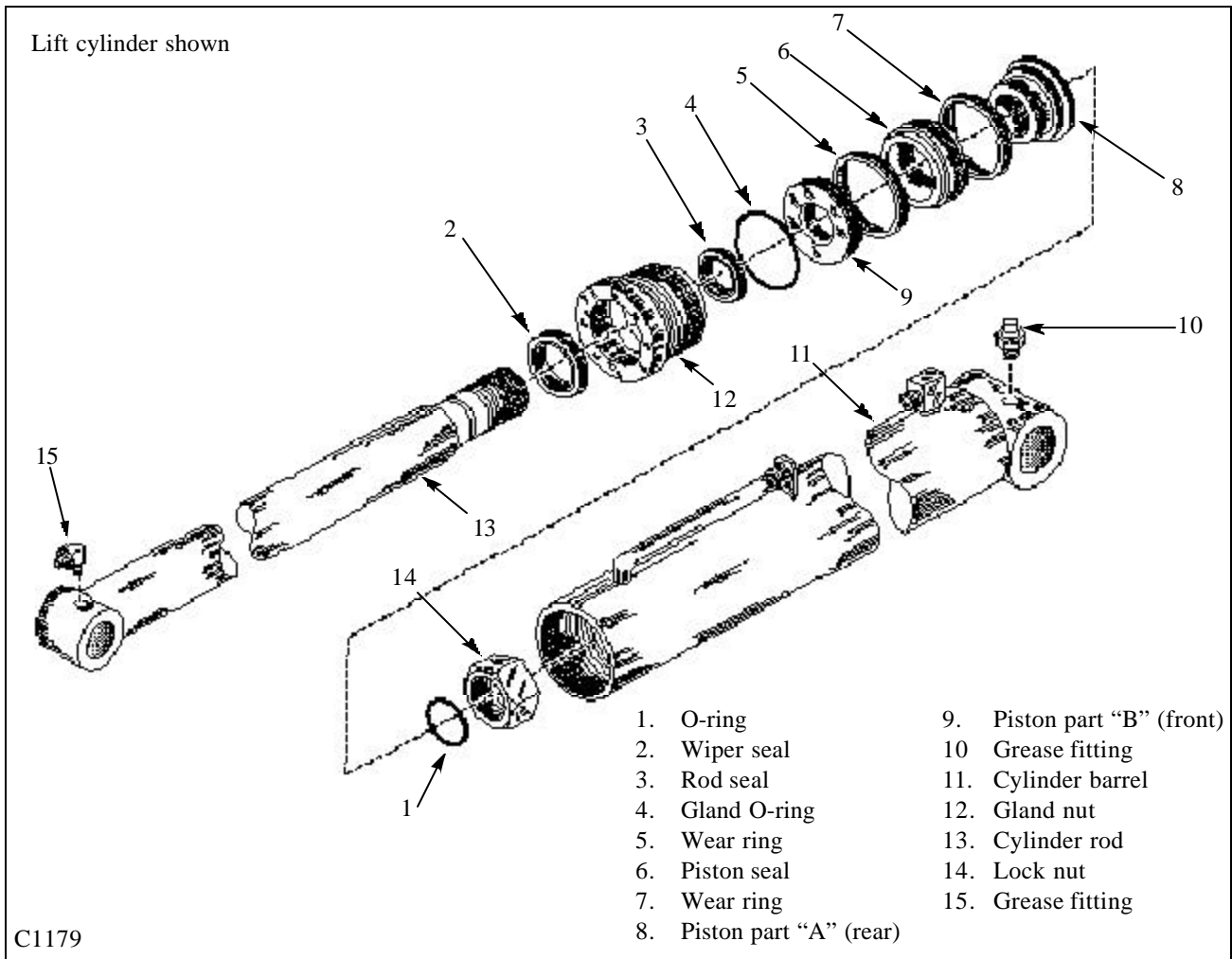

## General Information

All cylinders are a double acting, designed to extend and retract under pressure.

The piston rods, which are made of high strength distortion free material, are precision ground and hard chrome plated. The cylinders barrels are micro honed to close tolerance, straightness and smooth finish for long piston packing seal life.

All cylinders have a 2 piece piston assembly made of ductile iron and a polypac seal arrangement consisting of a piston seal and 2 wear rings.

The rod seal is a "U" cup design, with the "U" facing the pressurized oil. The rod wiper keeps foreign matter from entering the cylinder by wiping the rod clean as the cylinder retracts.

The gland nut seal is of an "O" - ring design. This seal keeps the oil from leaking around the gland nut and cylinder barrel threads.

Certain cylinders have spacers in them. These spacers are used to limit the stroke of the rod.

Some cylinders also have replaceable hardened bushings in the pivot areas that can be serviced when worn out.

# HYDRAULIC CYLINDERS 1.4

1

## Testing the Piston Seals

If the boom or bucket cylinders drift down with the control valve spools in the neutral position, and with no external leaks in the hydraulic system, the following test will indicate if oil is leaking by the cylinder piston seals. With the hydraulic oil at operating temperature and a fully loaded attachment, check that the cylinders do not drop more than 1.5 inches every 3 minutes with the engine off. Before performing this test, ensure the control linkages are not binding and the hydraulic control valve spools are centering in the neutral position. If the test has proven excessive leak down the cylinders may be further tested in the following manner.

### IMPORTANT

**Allowable boom or bucket cylinder drop: 1.5" in 3 minutes, @ loaded rating and operating temperature.**

### WARNING

**Never repair or tighten hydraulic lines while the engine is operating or the system is under pressure.**

- 1 This test must be performed with the engine running. Remove any attachment and block the loader securely with all 4 wheels off the ground.
- 2 Retract the cylinder(s) to be tested. Shut off the engine and cycle the controls to release the hydraulic pressure.
- 3 Disconnect the hose from the fixed end of the cylinder to be tested. Cap the hose with a steel plug to prevent system charge pressure from escaping the open circuit and to prevent contamination.
- 4 Start the engine and cycle the control(s) as to retract the cylinder. Do not over activate the controls as to place in the detent position. Have a container can ready to catch any waste oil to prevent environmental contamination.
- 5 Repeat for all both cylinders.
- 6 If oil leaks from the cylinder port the seals are bad and need replacement. If no oil leaks you may need to check the load check valves or spool wear in the hydraulic control valve.
- 7 Connect the hydraulic hose to the cylinder ports if no further servicing is required.

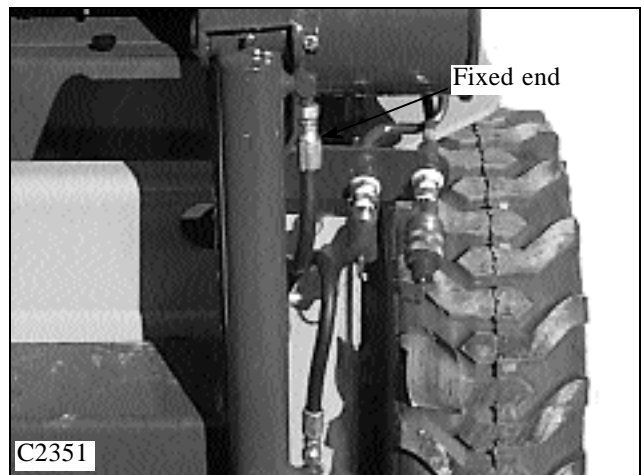
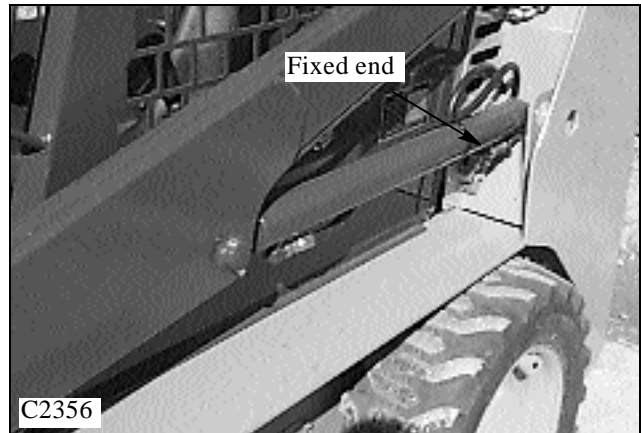

### WARNING

**Use extreme caution when checking the hydraulic system for leaks. Fluid under pressure can penetrate the skin and cause serious injury. Never use your hands to check for leaks.**

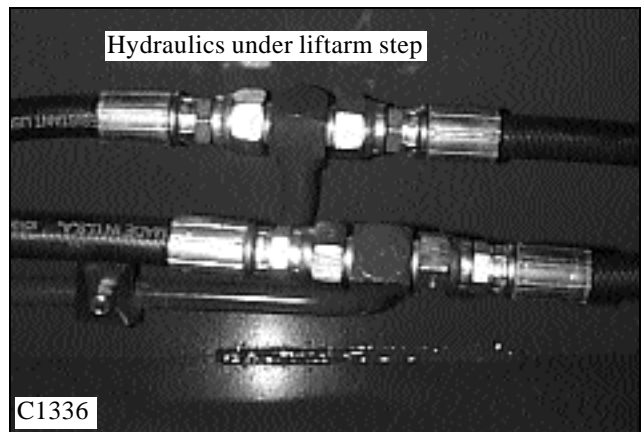

# HYDRAULIC CYLINDERS 1.4

## 1

### Lift Cylinder Replacement

#### IMPORTANT

When making repairs to the hydraulic system, keep the work area and parts clean. Use caps and plugs on all open lines and ports.

The following procedure will assist you in the cylinder removal.

For removal of the boom cylinders:

- 1 Lower the boom arms, stop the engine and cycle the controls to relieve any hydraulic back pressure in the system. Lock the control in the float or detent position.
- 2 Remove the hydraulic hoses from the cylinder. (fig. C2356) Cap all open ports and lines to prevent contamination.
- 3 Remove the lock nut and bolt from both mounting pins. (fig. C2413, C1864)
- 4 Remove the front pivot pin by pushing the pin out from behind the boom arm, out toward you. (fig. C1876) With an appropriate punch and hammer to prevent brooming of the pin, remove the rear pin. (fig. C1877) Brooming the pin makes it difficult to remove.
- 5 Remove the cylinder from the loader.
- 6 Upon replacement, inspect the pivot pins and cylinder bushings for any wear. Replace if necessary. Reverse order above for installation.
- 7 Upon start up, check for system leaks and replenish the hydraulic reservoir as required.

#### WARNING

Use extreme caution when checking the hydraulic system for leaks. Fluid under pressure can penetrate the skin and cause serious injury. Never tighten or repair hydraulic lines while the engine is operating.

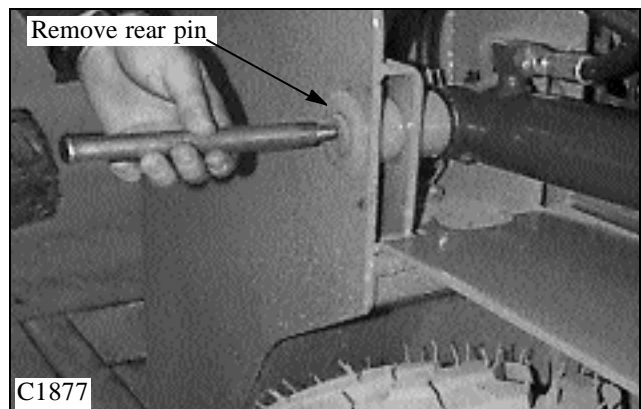
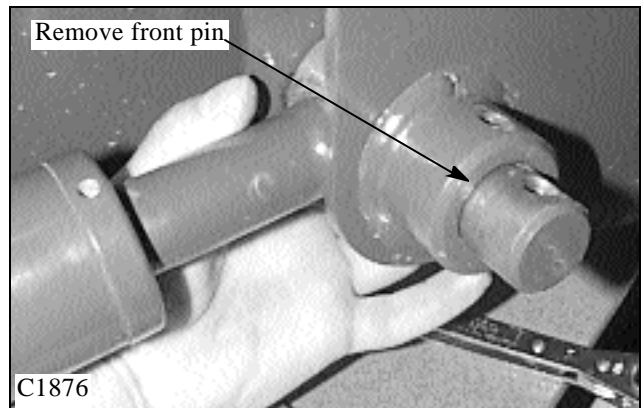
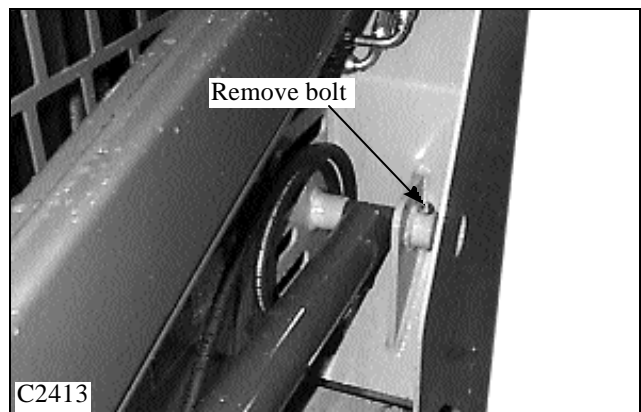
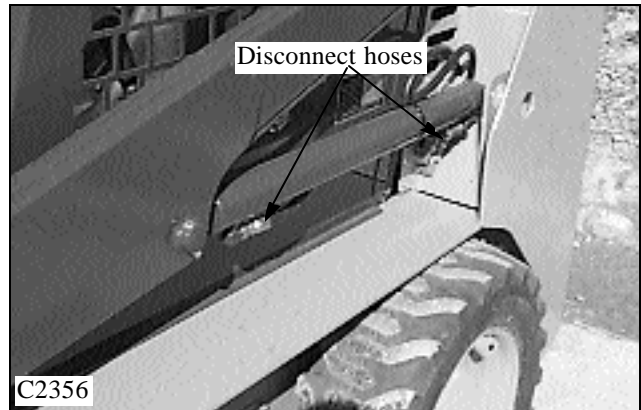



# HYDRAULIC CYLINDERS 1.4

1

## Tilt cylinder Replacement

For tilt cylinder removal:

- 1 Lower the boom arms, remove any attachment and extend the tilt cylinders. Shut off the engine and cycle the controls to relieve excessive back pressure in the hydraulic system.
- 2 Loosen or remove the hydraulic hoses from hydraulic tubing under the boom arm step if you are changing the hoses also. (fig. C1336)
- 3 Remove the hydraulic hoses from the tilt cylinder. Plug and or cap all open ports or lines to prevent contamination. (fig. C2414a)
- 4 Remove the lock nuts from the bolts retaining the pivot pins to the loader and remove the bolts. (fig. C2414)
- 5 Remove the pivot pins.
- 6 Remove the cylinder from the loader.
- 7 Upon reassembly, inspect the pivot pins and bushings for wear and replace as required. Reverse order for cylinder installation.
- 8 Upon start up, check for system leaks and replenish the hydraulic oil reservoir as required.

### WARNING

Use extreme caution when checking the hydraulic system for leaks. Fluid under pressure can penetrate the skin and cause serious injury. Never tighten or repair hydraulic lines while the engine is operating.

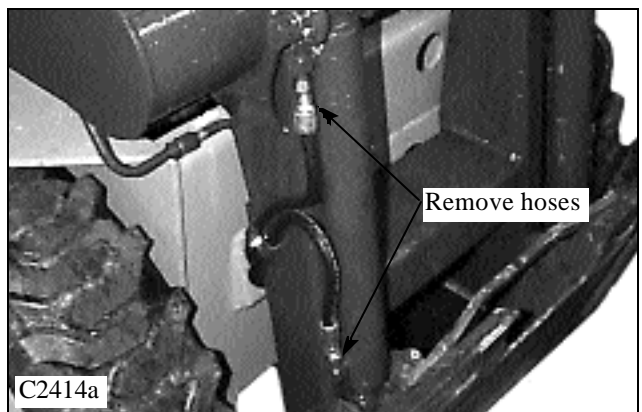
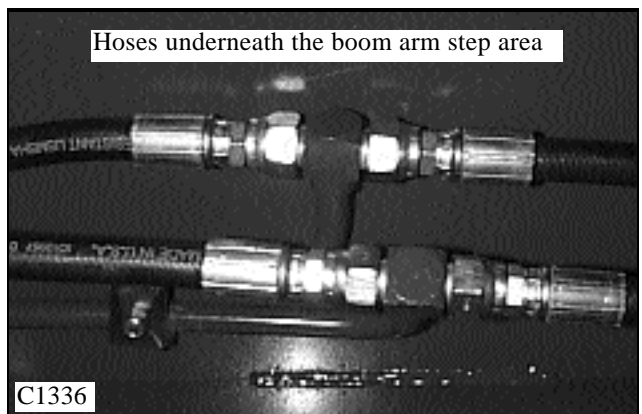
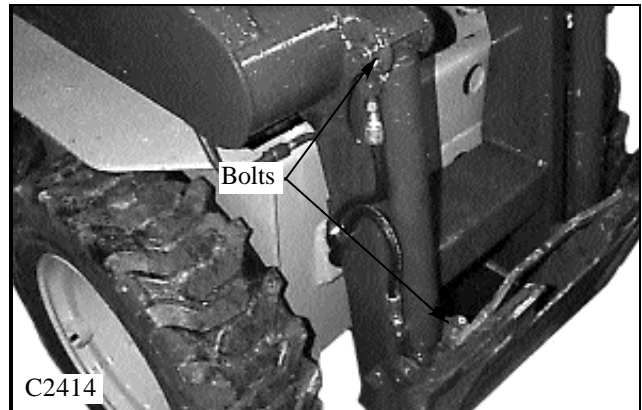

# HYDRAULIC CYLINDERS 1.4

## 1

### Cylinder Disassembly

Before Attempting repairs to the hydraulic cylinder, clean the body with a suitable solvent. Ensure all openings are plugged to prevent solvent from entering the cylinder.

- 1 Remove the cylinder as outlined previously.
- 2 Place the base end of the cylinder in a vise and support the front end of the body. Remove the plugs from the hose ports. (fig. C125)
- 3 Loosen the gland nut from the cylinder barrel using a spanner wrench. The gland nut threads are coated with loctite bonding agent at time of assembly. It may be necessary to apply heat to the gland nut and cylinder barrel threaded area, with a torch, to ease removal. (fig. C125)
- 4 Remove the gland nut, rod and piston seal assembly from the barrel. (fig. C329)

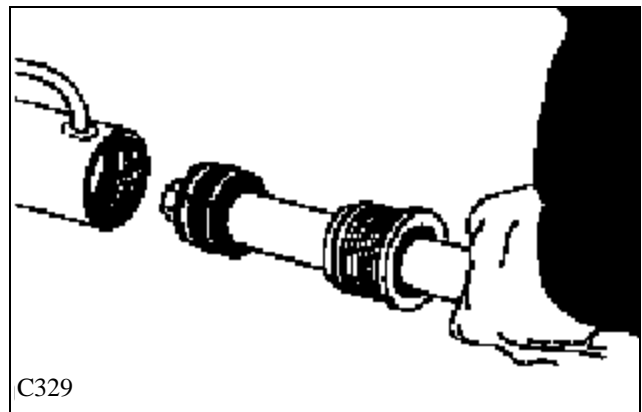
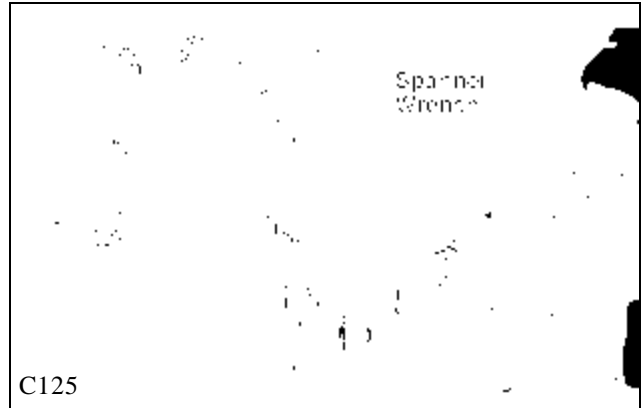

- 5 Place the cylinder rod bushing end in a vise and remove the lock nut from the rod. (fig. C128)

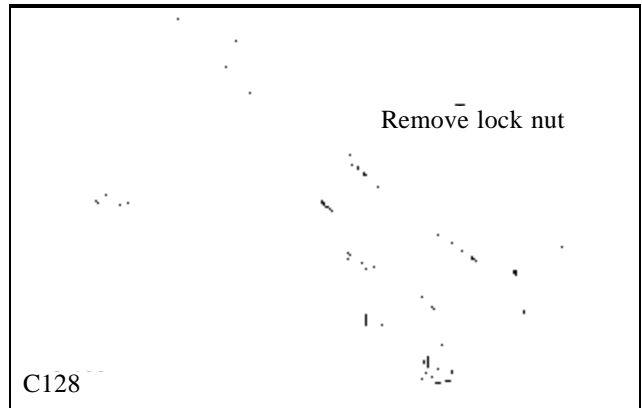

- 6 Remove the 2 piece piston assembly from the rod. (fig. C126)
- 7 **NOTE:** Some piston assemblies rear piston parts are threaded onto the rod. You will need to use a spanner wrench to remove this type of rear piston.

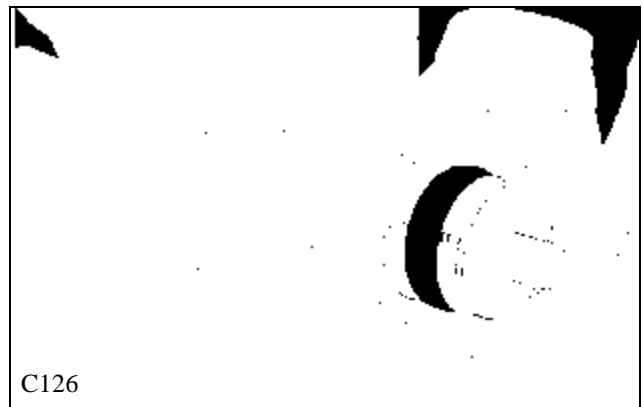

# HYDRAULIC CYLINDERS 1.4

1

8 Depending on the design of the rear piston, non threaded type, remove and discard the o-ring seal from the end of the cylinder rod. (fig. C127)

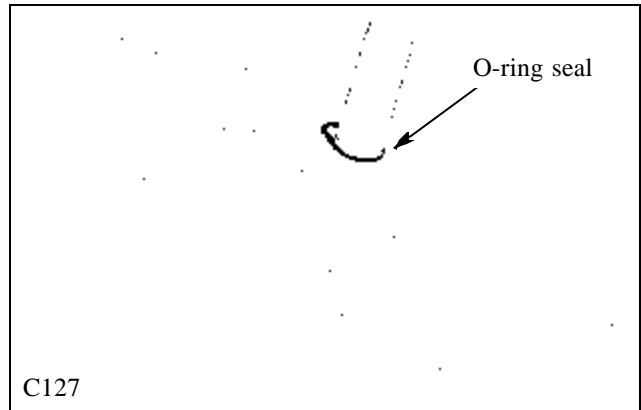

9 Remove the gland nut assembly from the cylinder rod. (fig. C330)

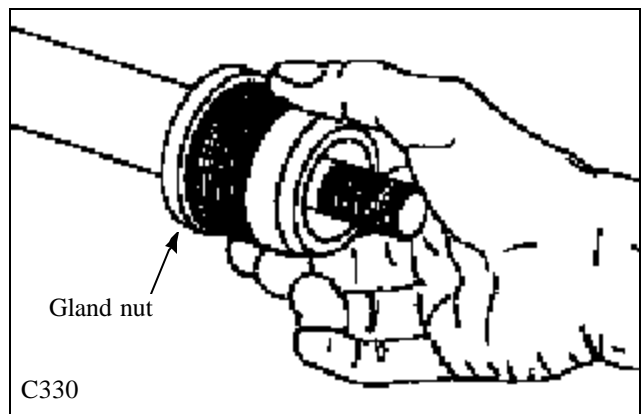

10 Remove and discard the wiper seal, rod seal and o-ring seals and teflon back up washer, (if used), from the gland nut assembly. (fig. C612) NOTE: Some seal designs may vary from illustration

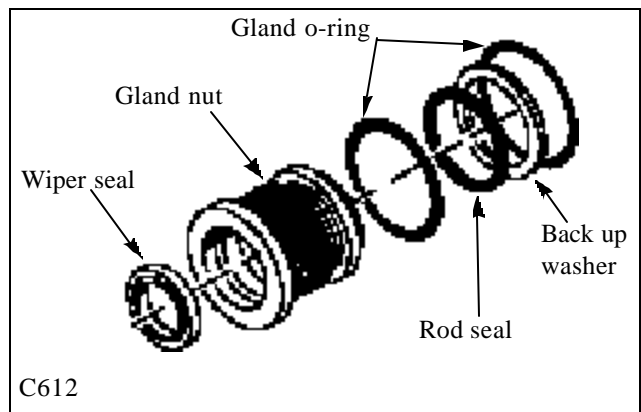

11 Remove and discard the wear rings and piston seal from the piston assembly. (fig. C130)

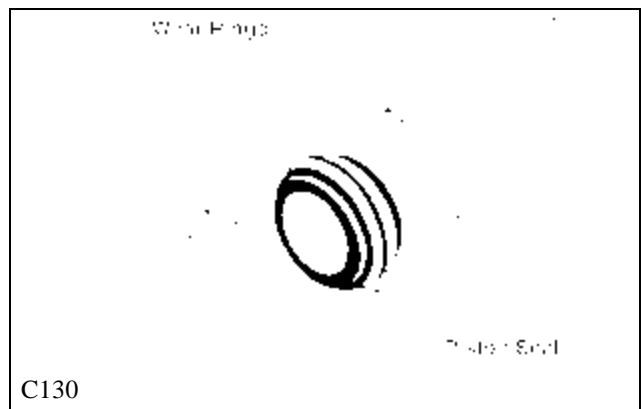

# HYDRAULIC CYLINDERS 1.4

## 1 Cylinder Inspection

- 1 Inspect the cylinder rod for scratches, dents and other damage. Minor rod damage may be repaired using a fine abrasive. Major scratches or dents are not repairable and the rod must be replaced. The chrome surface must be intact to provide a rust resistant surface. Blemishes on the rod will damage the rod seal and wiper and will cause leaking after a short period of use.
- 2 Inspect the cylinder rod threads. The threads must be in good condition to withstand the high torque required to secure the piston assembly to the rod.
- 3 Inspect the gland nut for nicks, burrs or other damage. Minor damage may be repaired using a fine abrasive.

Smooth down edges that could damage seals and cause leakage.

- 4 Inspect the gland nut threads for damage.
- 5 Inspect the piston assembly for damage. Remove minor scratches or damage with a fine abrasive.
- 6 Using a suitable light, inspect the cylinder barrel bore for scratches, dents, burrs or any other damage. Replace the cylinder barrel if there is any evidence of damage.
- 7 Inspect the cylinder barrel threads for damage. The threads must be in good condition to withstand the high torque required to secure the gland nut assembly to the cylinder barrel.

## Cylinder Assembly

1 Install a new gland nut rod seal. Form the seal into an oval shape and place it into the gland nut, with the “U” side of the seal facing the barrel end, and slip the seal into the groove. (fig. C129, C131)

- 2 Install a new wiper seal in the gland nut. (fig. C129, C131)
- 3 Install a new gland nut o-ring seal. (fig. C129, C131)

4 Apply system oil to the cylinder rod and assemble the gland nut assembly to the rod. (fig. C132)

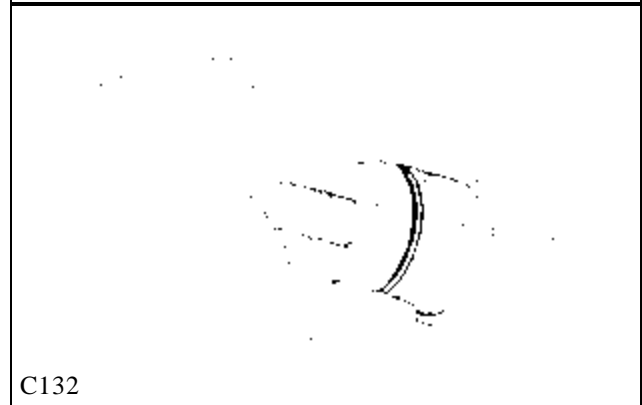
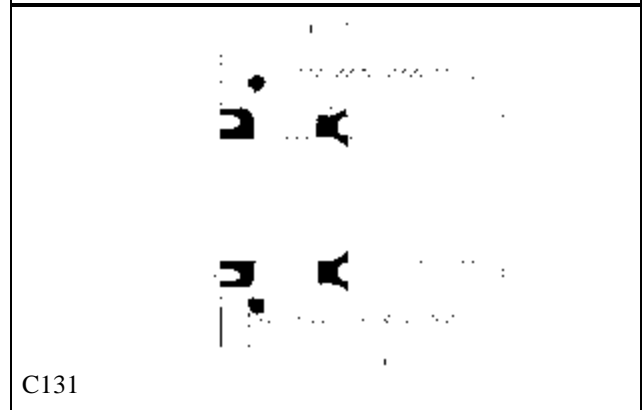
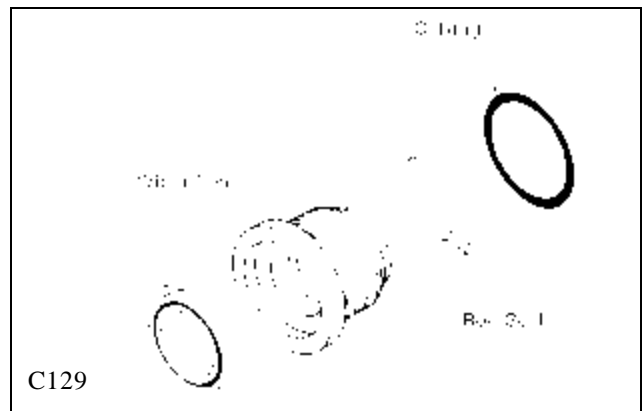

# HYDRAULIC CYLINDERS 1.4

1

5 Install a new o-ring seal on the cylinder rod if used. Some cylinder rod are fully threaded here to accommodate a threaded type rear piston part. (fig. C133)

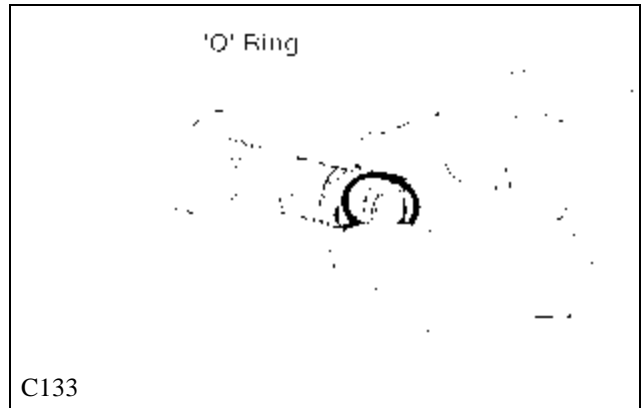

6 Install new wear rings and piston seal to the the 2 piece piston assembly. (fig. C130)

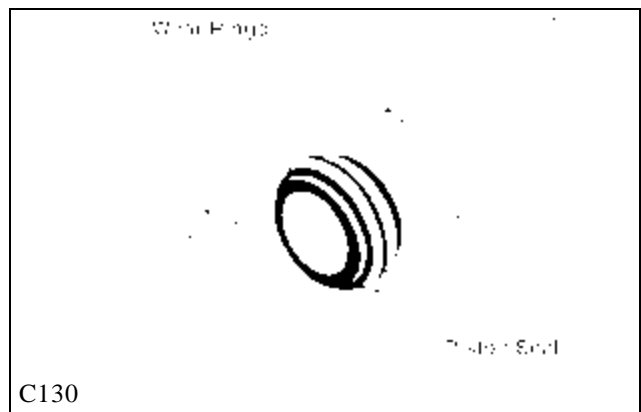

7 Install the piston assembly to the cylinder rod. Some rear piston assemblies are threaded onto the cylinder rod. Use a spanner wrench to install the rear piston part to the cylinder rod. Torque the lock nut to the rod at 150 ft / lbs (204 N.m.). (fig. C128)

8 Make sure the inside bore of the cylinder barrel is clean. Lubricate the inside of the barrel with system oil. Do not get oil into the threaded area of the barrel.

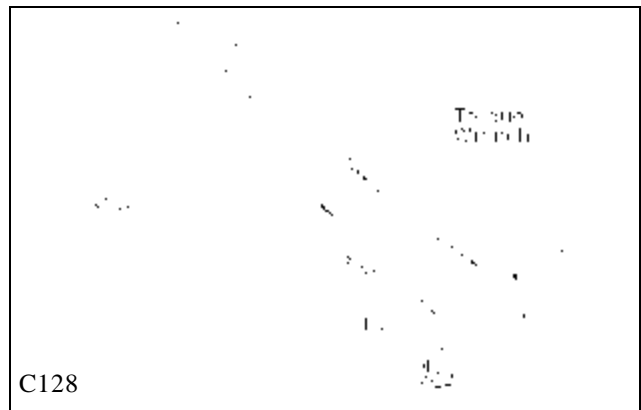

9 Lubricate the piston seal assembly with system oil and install the cylinder rod and piston assembly to the cylinder barrel. (fig. C329)

10 Apply loctite 242 to the gland nut threads and tighten the gland nut using a spanner wrench. Tighten the gland nut as much as you can using the spanner wrench. Make sure the threaded area of the gland nut and cylinder barrel are free of oil before applying the loctite bonding adhesive.

11 Assemble the cylinder to the loader. Use teflon tape or equivalent on the threads of the hydraulic hose ends, if the hose ends are of the taper pipe thread type.

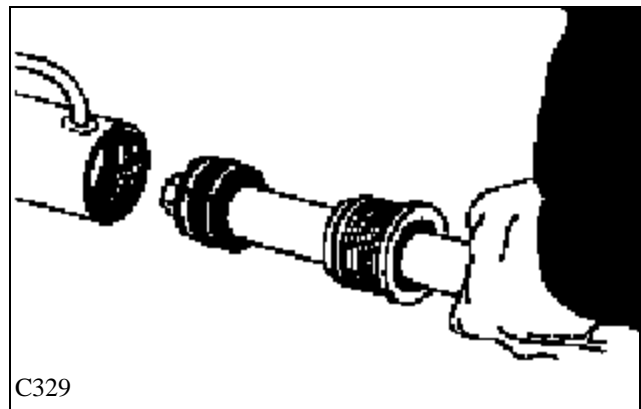

# HYDRAULIC OIL FILTER 1.5

## 1

### General Information

The hydraulic oil filter is located in the engine compartment, accessed by opening the rear door and lifting the engine compartment cover. The filter is mounted on the left side, on the oil reservoir.

All oil returning from the control valve is filtered before being used up by the hydraulic system.

The hydraulic oil filter is a spin on type with a 10 micron rating. The filter material is a resin impregnated cellulose which features an accordion pleated design to provide maximum filtration area. Only Thomas approved filters should be used.

The filter mounting head has a built in bypass valve that diverts oil around the filter when more than 25 psi (34 nm) differential pressure is required to force oil through the filter.

### Filter Replacement

**The hydraulic oil filter must be changed after the first 50 hours of operation and every 150 hours thereafter, or sooner if the pressure gauge dictates.**

- 1 Lower the boom arms, shut off the engine and engage the parking brake.
  - 2 Open the rear door and raise the engine compartment cover to gain access to the hydraulic filter. (fig. C2347, C2354)
  - 3 Clean the area of excess dirt if necessary to prevent contaminating the new filter when installing
  - 4 Remove the hydraulic oil filter using a proper sized filter wrench. Check to make sure the o-ring seal has come off with the used filter. (fig. C1868)
  - 5 Lubricate the new filter seal with clean system oil.
  - 6 Install the filter and fit hand tight.
  - 7 After start up, check the system for oil leaks.
- Replenish the oil reservoir as required with API 10W30 class SE / CD. (fig. C892, C1108)

#### WARNING

**Never repair or tighten hydraulic lines while the engine is operating or the system is under pressure.**

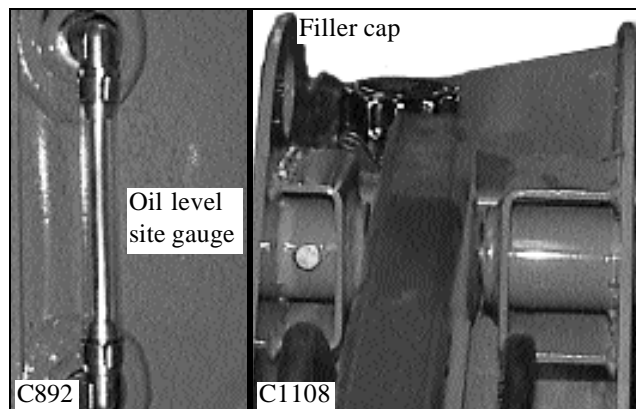
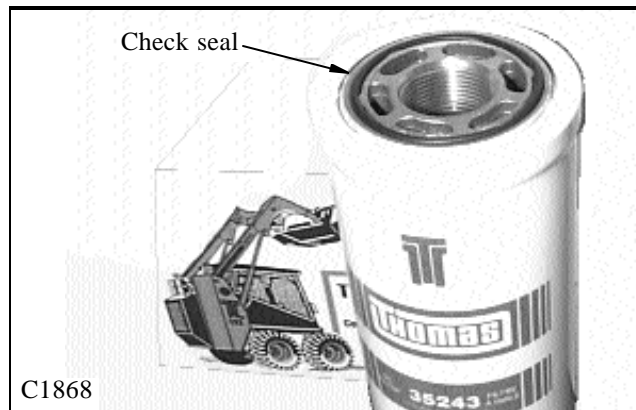
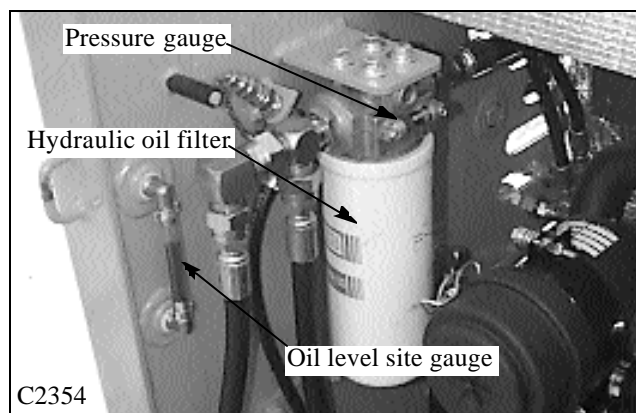
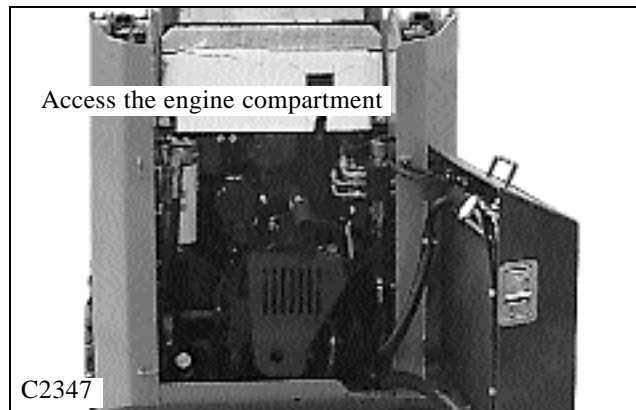

# HYDRAULIC OIL COOLER 1.6

## General Information

The hydraulic oil cooler is mounted to the inside of the rear door. (fig. C2932) Oil returning from the control valve is circulated through the oil cooler before being sent on to other parts of the hydraulic system.

An engine driven cooling fan drives air through the oil cooler when the rear door is closed.

The oil cooler is rated at 250 BTU / minute.

The oil cooler should be checked daily for dirt build up on the cooling fins. If air flow is restricted through the cooling fins, over heating of the hydraulic system may occur. Clean any dirt build up with compressed air. Flush with water if necessary.

### WARNING

**To avoid eye injury, always use safety goggles when cleaning with compressed air.**

## Cooler Replacement

- 1 Lower the boom arms, engage the parking brake and shut off the engine.
- 2 Open the rear door.
- 3 Connect a vacuum system to the oil reservoir filler spout, if available, or drain the hydraulic oil reservoir. Be prepared to contain 34 liters of fluid (9 gal). Use clean containers if the oil is to be reused.
- 4 Remove the cooler hoses. Plug the open hoses and cooler ports to prevent contamination.
- 5 Remove the cooler from the rear door.
- 6 Remove the fittings from the oil cooler.
- 7 Inspect the fitting o-rings for damage and replace if necessary.
- 8 Install the fittings into the new or repaired oil cooler following the torque chart on section 1.10. Be sure to support the cooler as the fittings are tightened to prevent damaging the cooler.
- 9 Replace the cooler & cooler lines. Follow the torque chart on section 1.10 when tightening the hydraulic hoses.
- 10 Replenish the hydraulic fluid as required. Check for system leaks and check the fit of the shroud seal to the engine radiator. Adjust if necessary.

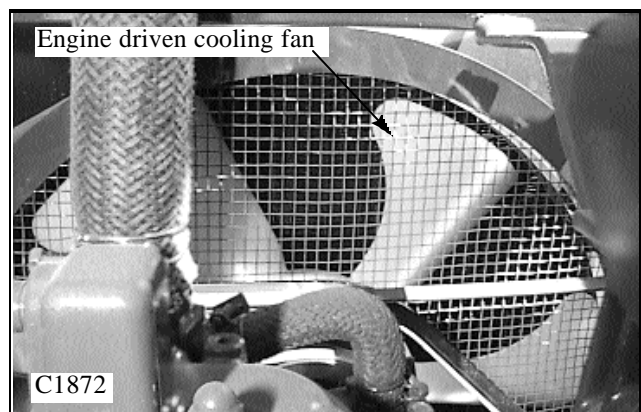
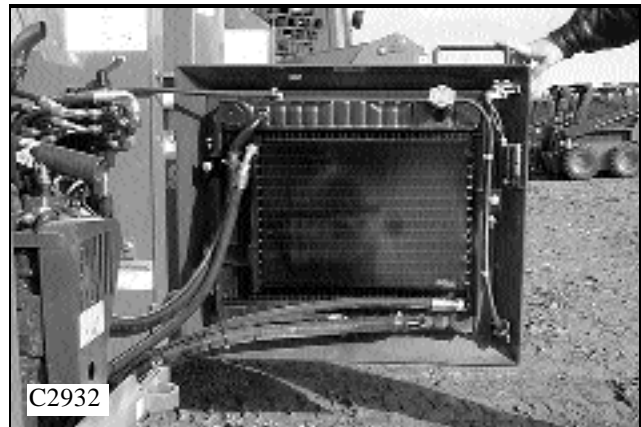

# HYDRAULIC OIL RESERVOIR 1.7

## 1

### General Information

The hydraulic oil reservoir is located at the rear of the loader on the left hand side. (fig. C2934) The reservoir is completely separated from all chain and gear drives to eliminate contamination. A magnetic drain plug is installed in the bottom of the reservoir, and a magnet is attached to the 100 micron suction filter, to assist in removing metal particles from the oil.

Oil level is checked through a sight gauge located just inside the engine compartment, left hand side, on the oil reservoir. The proper fill level is marked by a line and should be checked daily. (fig. C2354)

The oil reservoir fill cap is located at the top of the reservoir. (fig. C2355) The oil fill cap assembly has a 30 micron screen to catch larger particles of contaminant before entering the reservoir, but **always use oil filtered through a 10 micron min. filter for replenishing the hydraulic reservoir.** The oil fill cap is also a reservoir vent, or breather, and contains a 10 micron filter to remove air borne particles.

### Checking The Oil Level

- 1 Check the reservoir oil level with the loader on level ground.
- 2 Lower the boom arms, retract the cylinders and engage the parking brake. Shut off the engine.
- 3 Open the rear door. (fig. C2934)
- 4 Check the oil level in the sight gauge. (fig. C2354)
- 5 If oil is visible approximately mid way in the sight gauge, the level is correct.

### Adding Oil

- 1 Remove the bolt, or lock, on the reservoir filler cap.
- 2 Open the filler cap. (fig. C2355)
- 3 Inspect the filler screen in the filler neck for damage. If the filler screen is damaged, replace it.
- 4 Using a clean container, add 10W30 API class SE / CD oil.
- 5 Replace the filler cap and replace the bolt, or padlock, in the cap to prevent vandalism.

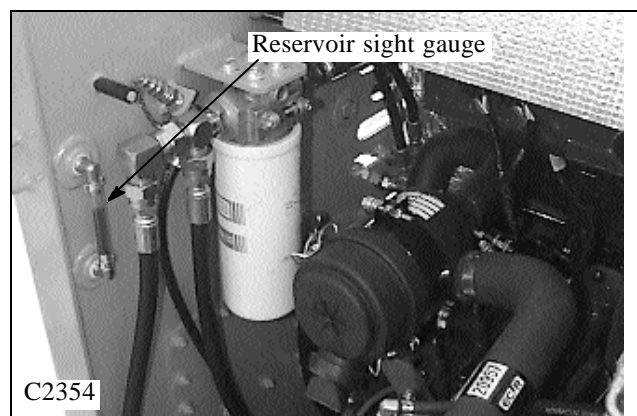
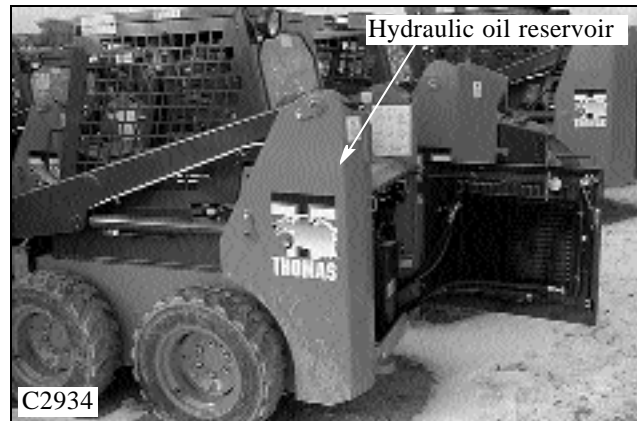

### IMPORTANT

**Always use filtered oil to replenish the hydraulic system.**

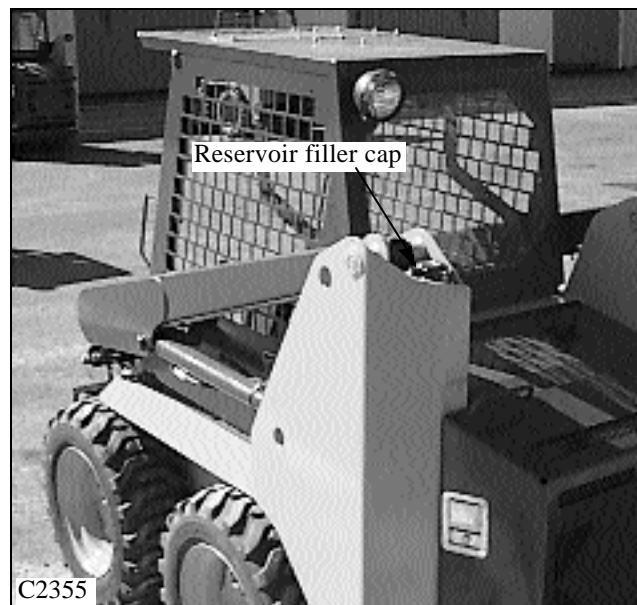



# HYDRAULIC OIL RESERVOIR 1.7

## Servicing The Oil Reservoir

Change the hydraulic oil, change the suction screen element and clean the magnet in the tank after every 1000 operating hours or if the oil has become contaminated or after any major hydrostatic drive system repair.

- 1 Lower the boom arms, shut off the engine and engage the parking brake.
- 2 Remove the magnetic drain plug located at the bottom of the hydraulic oil reservoir. (fig. C1034) Clean any metal particles that may be attached to the magnet. Have containers ready to hold approximately 10 gallons (45 £) of fluid. Replace the drain plug using teflon sealing tape or liquid type sealant on the plug threads.
- 3 Access the suction screen element in the hydraulic reservoir by removing the inspection cover on the reservoir, located in the engine compartment. (fig. C2357) Clean the excess silicone from the cover and reservoir.
- 4 Remove the suction screen element from the reservoir by turning counter clockwise. (fig. C1769, C1777)
- 5 Remove and clean the magnet attached to the suction element. (fig. C1769)
- 6 Install the magnet onto a new suction element and install the suction element.
- 7 Apply silicone around the inspection hole and install the inspection cover to the reservoir. Do not over tighten the mounting nuts. Maximum torque is 18 ft / lbs (24 N.m.).
- 8 Fill the reservoir to the proper level with 10W30 API classification SE / CD oil, approximately 13 gallons or 50 liters.

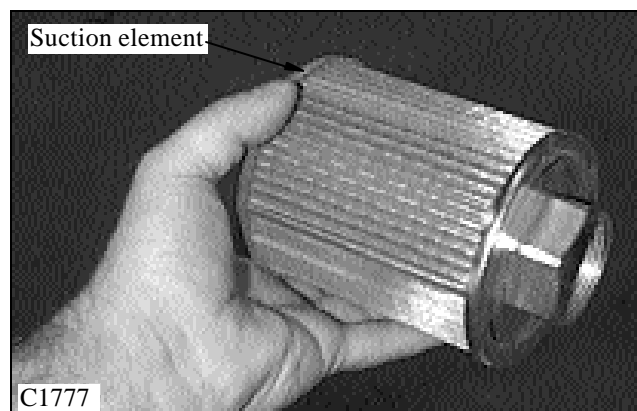
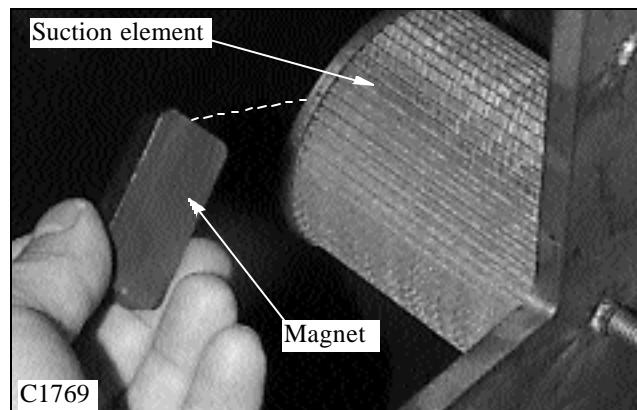
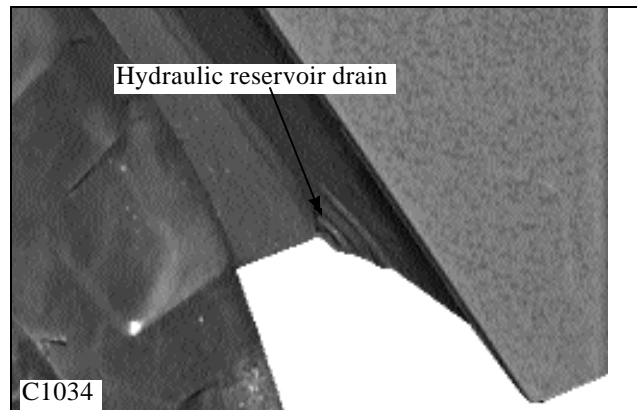

# TROUBLE SHOOTING 1.8

1

Problem	Cause	Corrective Action	Section
Loss of hydraulic power (no flow from the gear pump).	Reservoir low on oil.	Check for leaks. Fill the reservoir to the proper level.	1.8
	Universal joint between engine and tandem pump failure.	Inspect and replace the damaged parts as required. Check for proper alignment.	7.11
	Gear pump not functioning.	Inspect and replace damaged parts.	1.4 / 2.9
	Splined coupling failure in the hydrostatic pump	See the Sauer Sundstrand Repair Manual BLN 9992.	2.10
Loss of hydraulic power (full flow from gear pump).	Electrical failure.	Check fuse, switches and wiring.	8
	Auxiliary hydraulics engaged.	Disengage the switch.	4.9
	Relief valve failure or out of adjustment.	Check pressure. Adjust or repair as required.	1.4
	Control locks engaged	Check fuse, safety switches and valve lock parts.	1.4 / 8
Hydraulic action jerky.	Reservoir low on oil.	Check for leaks. Fill the reservoir to the proper level.	1.8
	Control linkages loose or worn.	Inspect, adjust or replace parts.	4
	Air in hydraulic system.	Check for leaks between the oil reservoir and pump.	
	Load check valve not functioning.	Inspect and replace damaged parts.	1.4
	Control valve spool spring return mechanism not functioning	Inspect and replace damaged parts.	1.4
Boom raises slowly at full RPM	Reservoir low on oil.	Check for leaks. Fill the reservoir to the proper level.	1.8
	Control linkages loose or worn.	Inspect, adjust or replace parts.	4
	Auxiliary hydraulics engaged.	Disengage the switch.	4.9
	Lifting more than rated capacity.	Reduce the load.	
	Engine RPM too low.	Check engine RPM and reset.	7.11
	Relief valve failure or out of adjustment.	Check pressure. Adjust or repair as required.	1.4
	Cylinder seal(s) failure.	Check seals.	1.5
	Internal leakage in the control valve.	Inspect the control valve and repair as required.	1.4
Hydraulic cylinders will not support a load. (leak down)	Control valve spools not centering.	Check control linkage and control valve spool spring centering devise.	1.4 / 4
	External leak between control valve and cylinders	Inspect and repair.	
	Cylinder seal(s) failure	Check seals.	1.5
	Load check valve not functioning.	Inspect and replace damaged parts.	1.4

# TROUBLE SHOOTING 1.8



Problem	Cause	Corrective Action	Section
Hydraulic oil overheating.	Reservoir low on oil.	Check for leaks and replenish as required.	1.7
	Oil cooler plugged or dirty. (if applicable)	Clean the cooling fins.	
	Auxiliary hydraulics engaged.	Disengage.	
	Temperature sender defective.	Replace.	8
	Relief valve failure or out of adjustment.	Check pressure, adjust or replace.	1.4
	Wrong type of hydraulic fluid.	Replace.	1.7

# TORQUE CHART 1.9

## Hydraulic Hose and Fitting Torque Chart

**NOTE:** all torques are in lbs. / ft (Multiply by 1.36 = N.m.)

HOSE SIZE	37° JIC FITTINGS	HOSE SIZE	ORB FITTINGS
1/4	9 to 10	1/4	14 to 16
5/16	15 to 16	5/16	18 to 20
3/8	20 to 22	3/8	24 to 26
1/2	30 to 33	1/2	50 to 60
5/8	40 to 44	5/8	72 to 80
3/4	70 to 77	3/4	125 to 135
7/8	82 to 90	7/8	160 to 180
1	55 to 60	1	200 to 220
1 1/4	120 to 132	1 1/4	210 to 280
1 1/2	131 to 144	1 1/2	270 to 360
2	300 to 330		

The following torque specifications are for steel ORB fittings into aluminum.			
HOSE SIZE	ORB FITTINGS	HOSE SIZE	ORB FITTINGS
1/4	5 to 7	3/4	40 to 45
5/16	8 to 10	7/8	50 to 55
3/8	10 to 12	1	90 to 99
1/2	21 to 24	1 1/4	80to 90
5/8	27 to 30		

# NOTES



# THOMAS