

SECTION 3 FINAL DRIVE

Specifications & Maintenance	3.1
Chart	pg. 3-2
Lubrication	3.2
Checking the Oil	pg. 3-3
Adding Oil	pg. 3-3
Changing the Oil	pg. 3-3
Drive Chain	3.3
Checking	pg. 3-4
Removal	pg. 3-5
Installation	pg. 3-6
Drive Motor Sprocket	3.4
Replacement	pg. 3-7
Axle Assembly	3.5
Illustration	pg. 3-9
Removal	pg. 3-10
Inspection	pg. 3-11
Installation	pg. 3-12
Stud Replacement	pg. 3-15
Trouble Shooting	3.6
Chart	pg. 3-16



SPECIFICATIONS & MAINTENANCE 3.1

Specifications

Chain Size ANSI 60HT
 Approved Chain Manufacturer Tsubaki
 Lubricating Oil 10W30 API Classification SE/CD
 Oil Capacity (each)..... 7 Liters. (1.9 gal)

3

Torque Specifications:

Motor Sprocket Bolt..... 25 lbs /ft (34 nm)
 Wheel Nuts..... 100 - 110 lbs /ft (135 - 149 nm)
 Inspection Cover Nuts.....12 lbs /ft (16.5 nm)

Tire Pressure 50 psi (345 Kpa)

Maintenance	Initial Check (hrs)	Check Every (hrs)
--------------------	----------------------------	--------------------------

Tire Pressure.....	8.....	8
Wheel Nut Torque.....	8.....	8
Lubrication Oil.....	50.....	150 (*)
Chain Tension.....	50.....	150
Motor Mounting Nuts	50.....	150
Axle Bearing Pre-load.....	50.....	150

(*) Change every 1000 hours.

LUBRICATION 3.2

Checking The Oil Level

The loader has 2 independent final drive housings. When checking the oil level, ensure the loader is on a level surface.

- 1 Remove any attachment, raise the boom arms and engage the boom support pins. Shut off the engine.
- 2 Remove the top (upper) check plug located between the 2 tires at the very front of the loader. (fig. C597)
The oil level should be at the top of the check hole with a little to trickle out.

WARNING

Never work under a raised boom arm without the boom supports engaged and the engine shut off.

Adding Oil

Oil should be added with the loader on a level surface.

- 1 Remove any attachment, raise the boom arms and engage the boom support pins. Shut off the engine.
- 2 Remove the seat and hydrostatic shield (fig. C2358).
- 3 Remove the vented oil filler plug (fig. C2360).
- 4 Add 10W30 API classification SE/CD oil until it begins to flow out the upper check hole. Total final drive housing capacity per side is 7 liters (1.9 gal).
- 6 Replace all plugs. Apply thread sealant to vented filler plug (fig. C2279).

WARNING

Check the final drives closely for damaged seals or other leaks if the oil level is excessively low.

Changing The Oil

Ensure the loader is on a level surface before changing the oil.

- 1 Remove any attachment, raise the boom arms and engage the boom support pins. Shut off the engine.
- 2 Slide a drain pan under one of the lower drain plugs located at the front of the loader, between the 2 front wheels. (fig. C597) Be prepared to contain 7 liters (1.9 gal) of oil.
- 3 Remove the drain plug. Allow the oil to drip completely out of the final drive housing. Replace the drain plug. Dispose of the waste oil in an environmentally friendly manner. If the oil is contaminated, remove the side inspection cover to flush the housing.
- 4 Replenish the oil as outlined above in Adding Oil with 10W30 API classification SE/CD oil.

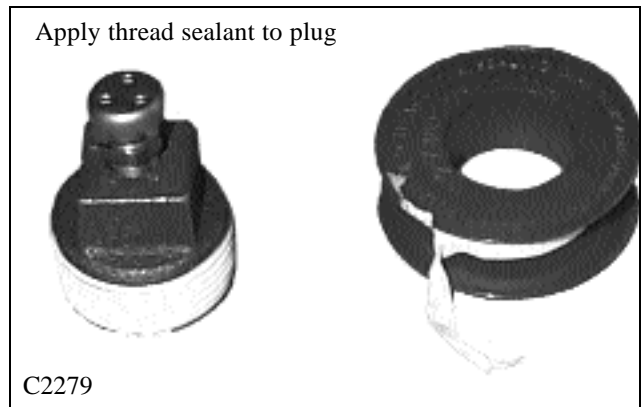
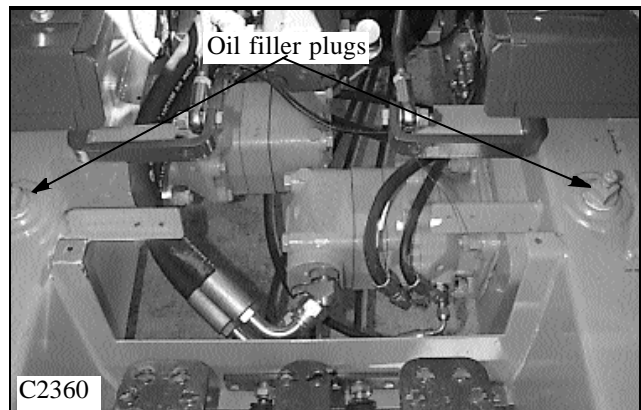
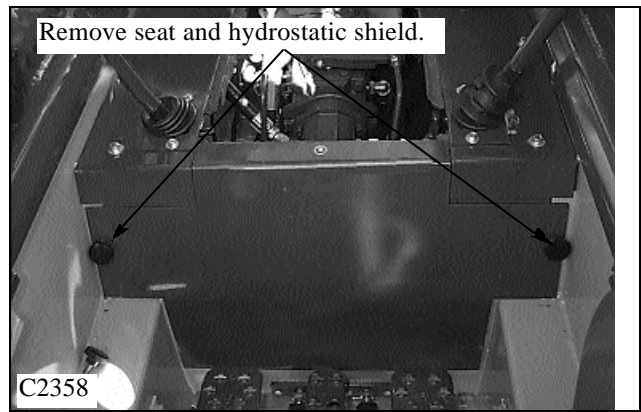
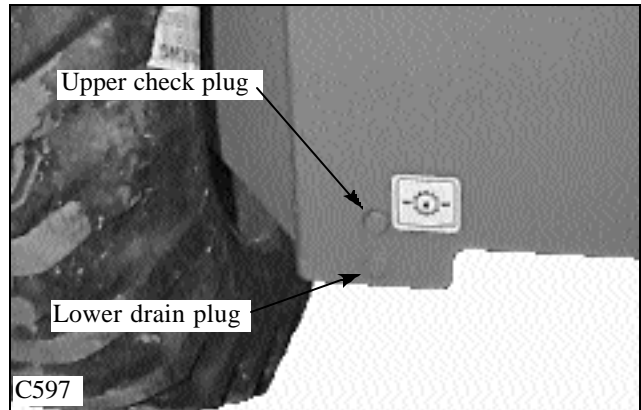

3

DRIVE CHAIN 3.3

Checking The Drive Chain

The drive chain must be checked for adjustment after the first 50 hours of service and every 150 hours thereafter. Correct chain tension is measured at 1/4 ~ 2 inches (6 to 50 mm) free play.

1 Remove any attachment, raise the boom arms and engage the boom support pins. Shut off the engine. Raise the loader securely with tires off the ground.

3

2 Remove the wheels and inspection cover located between the axle assemblies. (fig. C2073, C2424).

3 Using a ruler or tape measure, check the chain tension at the mid point (fig. C2425, C2426) between the drive motor and axle sprockets. Correct free play should be 1/4 ~ 2 inches of free play. (6 to 50 mm).

4 If chain tension measures with in specifications, reseal the inspection cover area with silicone. Be sure to clean the surface thoroughly before application.

If the chain tension is not with in specification, then the drive chain must be replaced. Be sure to inspect the drive sprockets for wear at this time also.

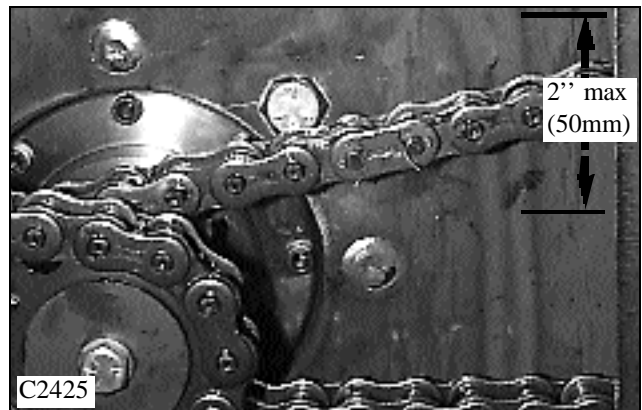
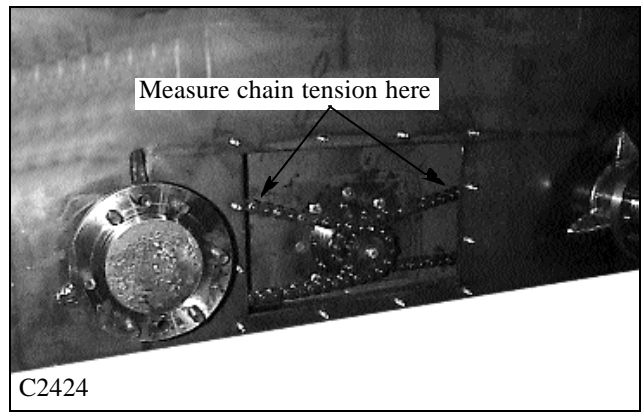
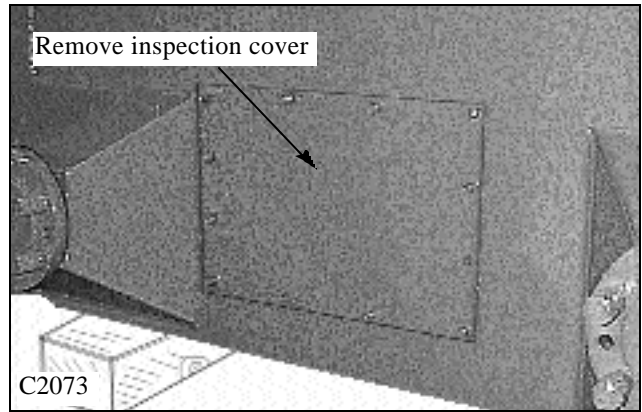

DRIVE CHAIN 3.3

Chain Removal

- 1 Remove any attachment, raise the boom arms and engage the boom support pins. Shut off the engine.
- 2 Block the loader securely with all 4 wheels clear of the ground.
- 3 Remove the wheels from the side of the loader the chain is to be removed.
- 4 Clean the excess dirt from the final drive housing drain plug area and the inspection cover area located between the 2 axle towers. (fig. C168)
- 5 Remove the lower drain plug and drain the oil. Refer to Section 3.2. (fig. C597)
- 6 Remove the final drive inspection cover. (fig. C168)
- 7 Rotate the chain, if necessary, to locate the master connecting link (fig. C2425) by starting the engine and engaging the steering control. Be sure the loader is securely raised clear of the ground.
- 8 Remove the cotter pins from the master connecting link and remove the connecting link (fig. C2425).
- 9 Remove the chain from the housing by turning the axles by hand and pulling the slack chain out the inspection cover area (fig. C2273). Hold the chain up off the drive sprocket to allow the chain to rotate freely.

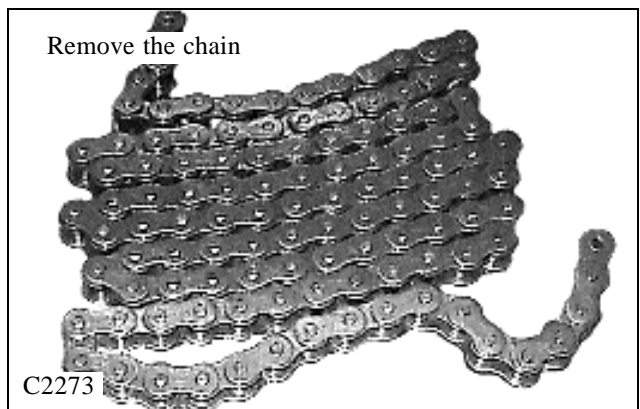
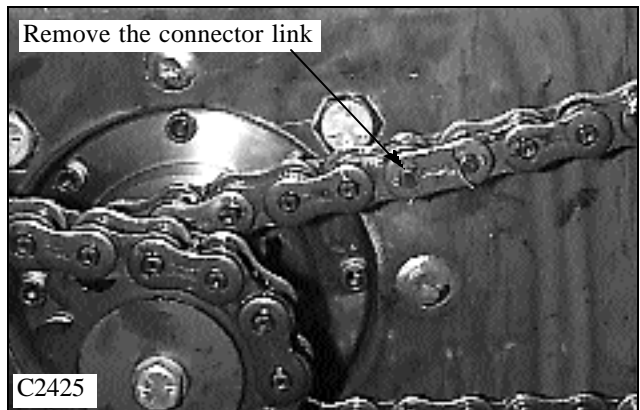
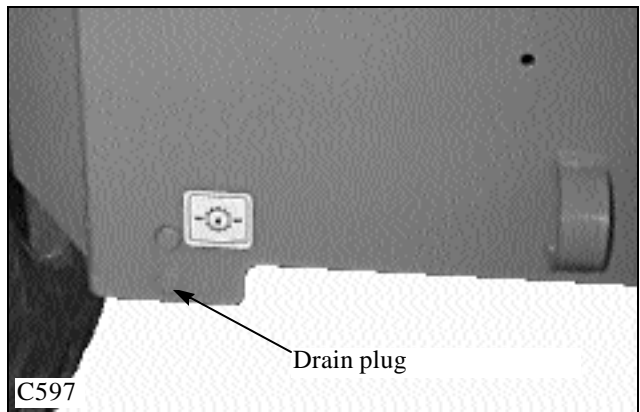
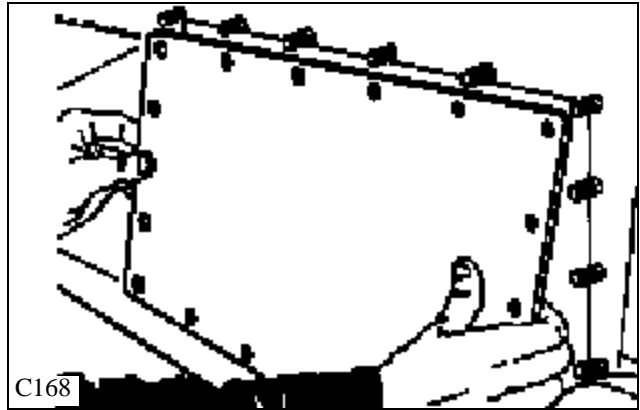

DRIVE CHAIN 3.3

Chain Installation

- 1 Wrap the chain in a “Z” pattern (fig. C2273).
- 2 Install the wrapped chain into the final drive housing.
- 3 Place one end of the chain over the top of the axle sprocket. Rotate the axle by hand and bring the chain along the bottom of the final drive housing to approximately the center.

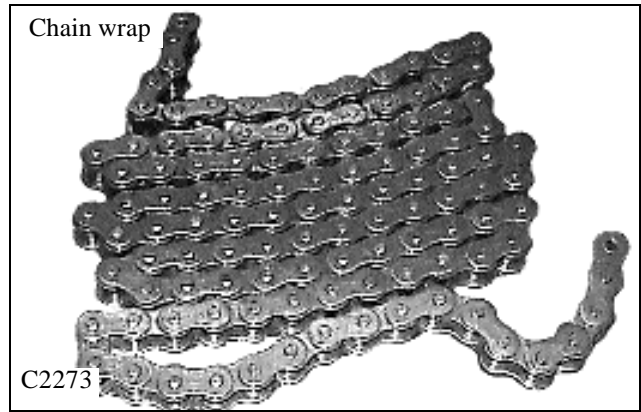

- 4 Wrap the chain around the drive motor sprocket and install a new connecting link (fig. C2427).

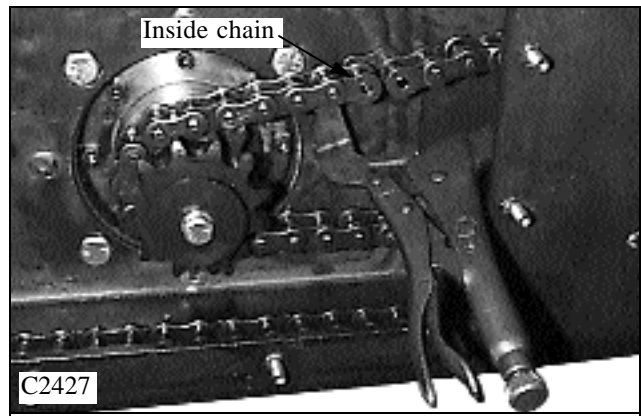

- 5 Place the connecting link into the chain so the inside chains connecting link has cotter pins face the inspection cover hole (fig. C2428). The connecting link on the outside chain, closest to the inspection cover opening, faces inward, (fig. C2429) toward the other chain. Bend the ends of the cotter pins at least 90° apart.

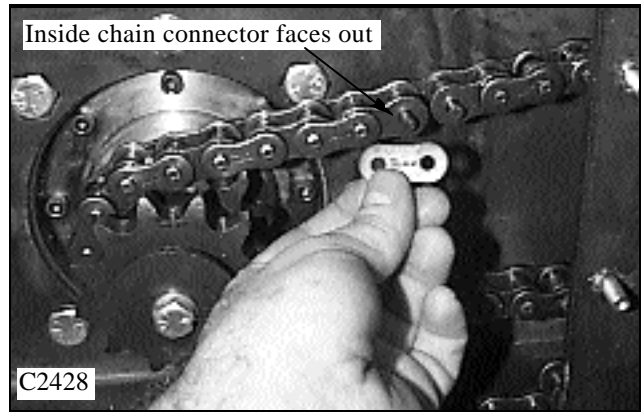

- 6 Check the chain tension as outlined on Section 3.3.

- 7 Replace the inspection cover using silicone. Do not over tighten the inspection cover nuts, 12 lbs / ft maximum. (16.5 nm). Be sure to clean sealing surfaces before silicone application.



- 8 Replace the wheels and torque the wheel nuts to 100 to 110 lbs/ft. (136 to 149 nm).

3

DRIVE MOTOR SPROCKET 3.4

Replacement

The torque motor drive sprocket can be removed from the loader without removing the drive motor from the final drive housing.

1 Place the loader on a level surface, engage the parking brake and shut off the engine.

2 Raise the loader securely from the ground and remove the wheels on the side to be worked on.

3 Remove the inspection cover located between the axle assemblies. (fig. C2424)

4 Disconnect both the front and rear drive chain connector links.

5 Remove the bolt retaining the drive sprocket to the drive motor. (fig. C2425)

6 Pull the drive motor sprocket from the shaft. Inspect the motor shaft for wear and replace motor parts if required. (See Section 2.)

7 Replace the drive sprocket in the reverse order above. Apply Loctite 242 (blue) to the drive sprocket bolt and torque the bolt to 28 lbs / ft (38 nm).

8 Replace the connecting links with new, reseal the inspection cover with silicone, and replenish the lubricating oil if needed.

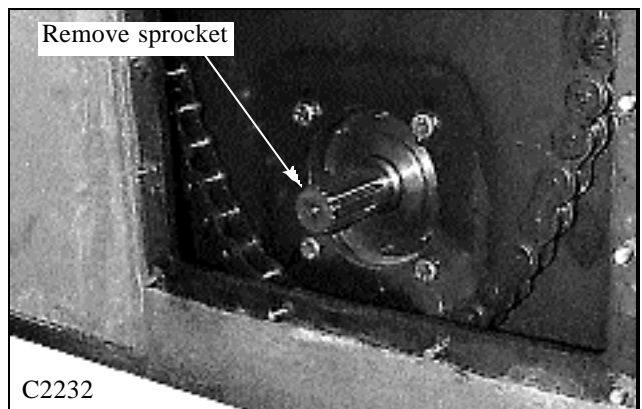
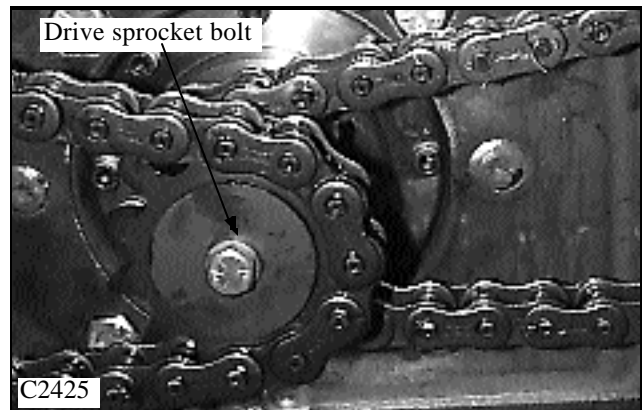
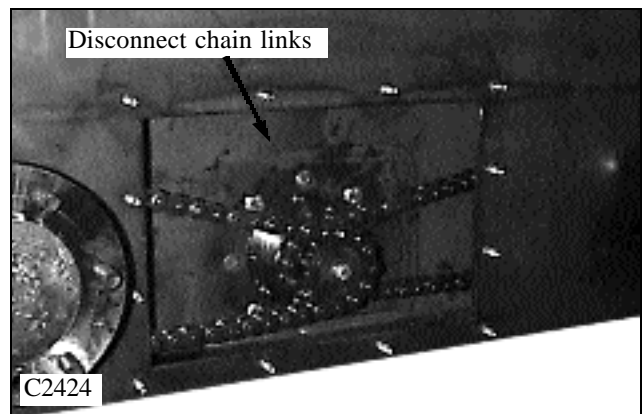
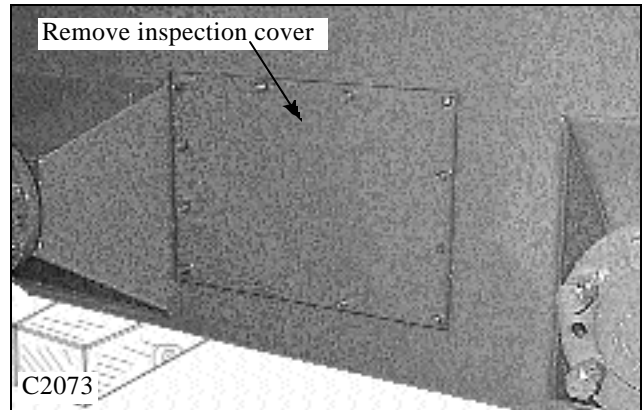

3



THOMAS

AXLE ASSEMBLY 3.5

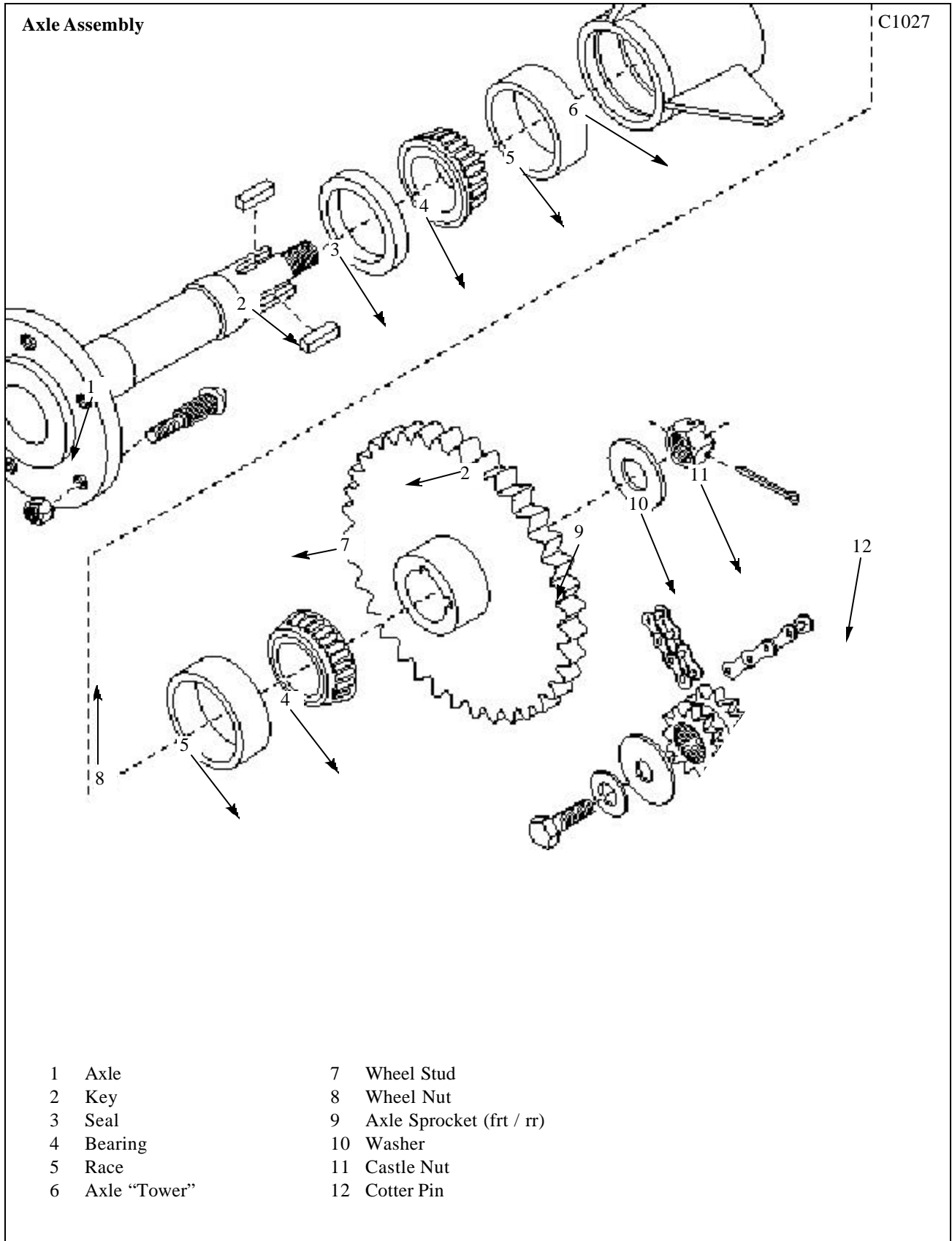

AXLE ASSEMBLY 3.5

Axle Removal

- 1 Remove any attachment, raise the boom arms and engage the boom support pins. Shut off the engine.
- 2 Block the loader securely with all 4 wheels clear of the ground.
- 3 Remove the wheels from the side of the loader the axle is to be removed.
- 4 Clean the excess dirt from the final drive housing drain plug area and the inspection cover area located between the 2 axle towers.
- 5 Drain the lubricating oil from the final drive housing. Refer to Section 3.2.
- 6 Remove the final drive inspection cover located between the 2 axles.
- 7 Remove the drive chain from the axle to be replaced.
- 8 **FRONT AXLE:** Remove the foot pedal assembly if so equipped. (Refer to Section 4).
- 9 Remove the inner axle cover plate from the final drive housing. (fig. C2430)
- 10 **REAR AXLE:** Remove the inner axle cover plate from the final drive housing.
- 11 Remove the split pin from the castle nut on the end of the axle. (fig. C2431)
- 12 Remove the castle nut and axle washer. The axle will need to be held stationary.
- 13 Using a special slide hammer type axle puller tool, (fig. C502) remove the axle assembly (fig. C228). (See special tools, Section 8).

3

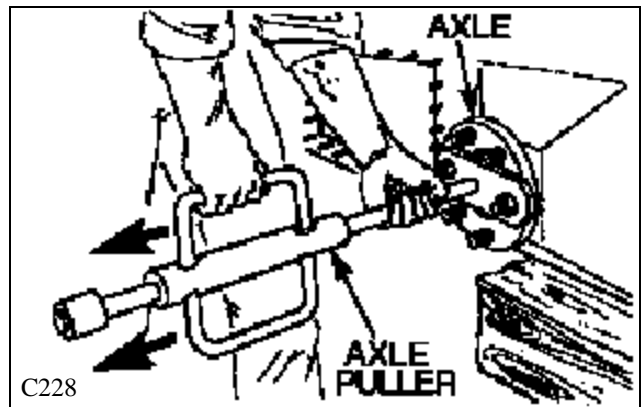
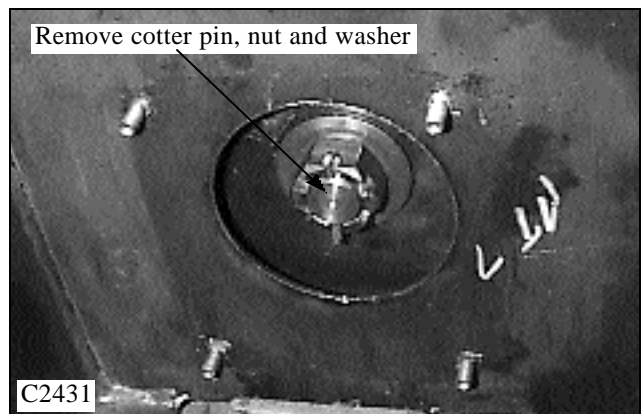
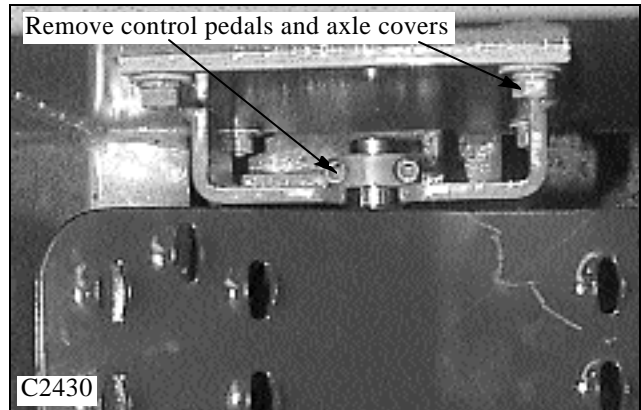

AXLE ASSEMBLY 3.5

Axle Removal

14 Retrieve the inside bearing, sprocket and axle sprocket keys from inside the final drive housing.

Please note the orientation of the axle sprocket on the axle and in the housing. Front and rear sprockets have a different offset.

15 Using a bearing puller, remove the bearing still pressed in place on the axle. (fig. C221)

16 Remove and discard the axle oil seal.

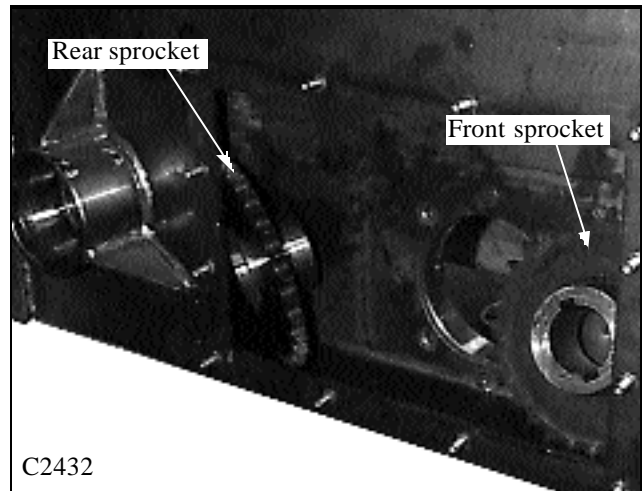

Inspection

1 Inspect the seal surface area for scaring, pitting or nicks. Minor scratches may be removed using fine emery cloth. Replace the axle if worn excessively.

2 Inspect the axle threads for damage. Replace axle if the threads are non serviceable.

3 Inspect the axle keys for wear. Replace as required.

4 Inspect the key way slots for wear. Replace the axle and keys if the keys do not fit tightly into the key ways.

5 Replace any axle studs as required.

6 Inspect the axle sprocket for abnormal tooth wear and the fit of the axle key in the sprocket key ways. Replace the sprocket if necessary.

7 Inspect the bearing races in the final drive housing. Replace them if necessary using a brass drift punch and hammer. Cooling the races in a freezer will aid in easing this procedure.

8 Replace the bearings if new races are installed or if they are pitted or damaged.

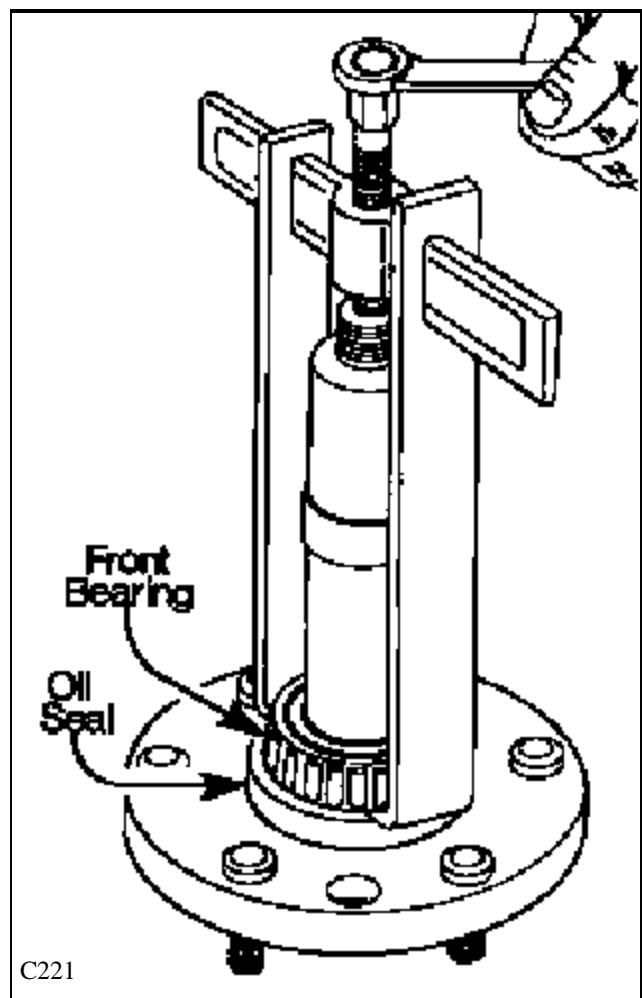

AXLE ASSEMBLY 3.5

Axle Installation

- 1 Check the axle seal surface area for damage. Minor scratches may be repaired using fine emery cloth.
- 2 Inspect the axle threads for damage. Replace axle if the threads are non serviceable.
- 3 Inspect the key way slots for wear. Replace the axle and keys if the keys do not fit tightly into the key ways.
- 4 Replace any axle studs as required.
- 5 Lubricate the axle oil seal with light grease.
- 6 Install the seal onto the axle. The seal part number stamping must face the flange side of the axle. (fig. C222)
- 7 Using a press, install the front, or outer, bearing onto the axle. Be sure to support the axle up off the wheel studs to prevent damaging the wheel studs. (fig. C223)

- 8 Place 3 seal installation tools, (See Special Tools, Section 8), equally spaced around the axle flange, behind the seal as shown in fig. C224. (approximately 120° increments). These special tools must be used to properly locate the seal into the final drive housing.

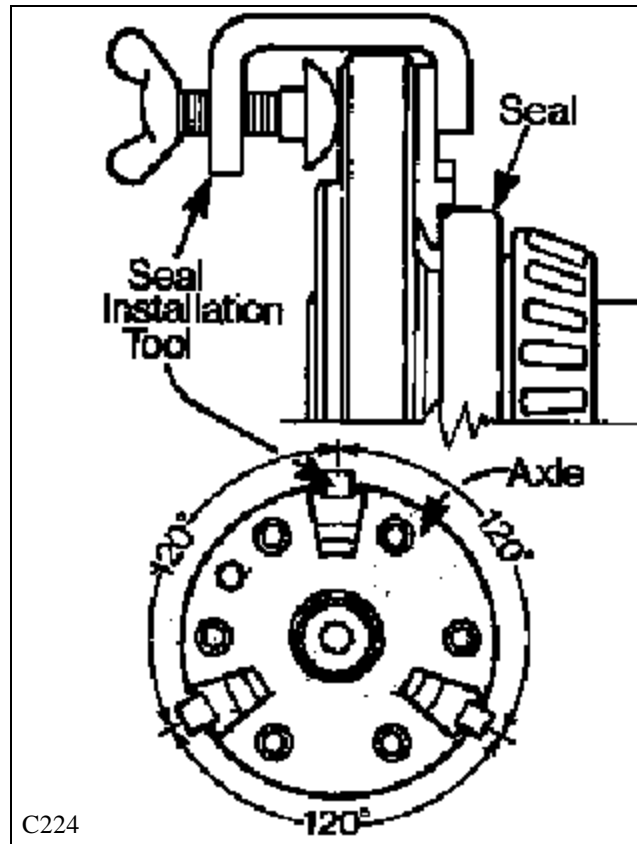
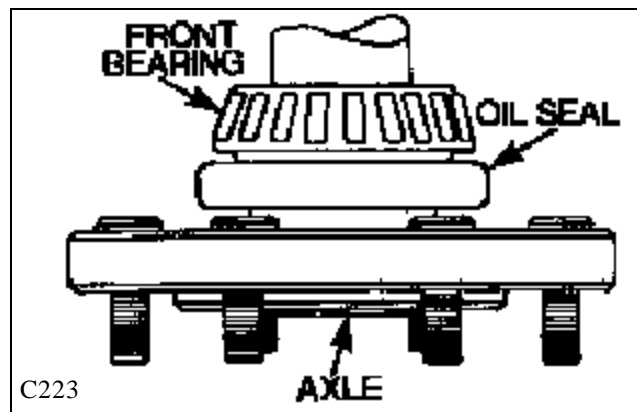
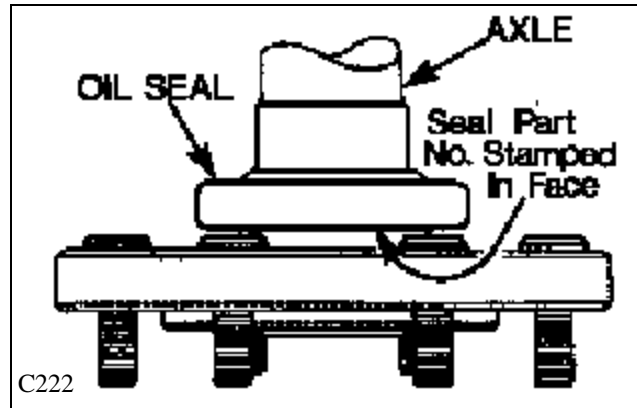

3

AXLE ASSEMBLY 3.5

Axle Installation (cont'd)

9 Place the axle sprocket into the final drive housing, make sure the hub offset is facing the proper way to align the chain with the drive motor sprocket.

10 Apply gasket sealant to the outer edge of the axle oil seal. (fig. C212) Take care, make sure none gets on the bearing surface.

11 Guide the axle into the final drive housing. (fig. C220).

12 Start the rear (inside) axle bearing onto the axle. (fig. C225).

13 Start the axle into the drive sprocket. (fig. C226).

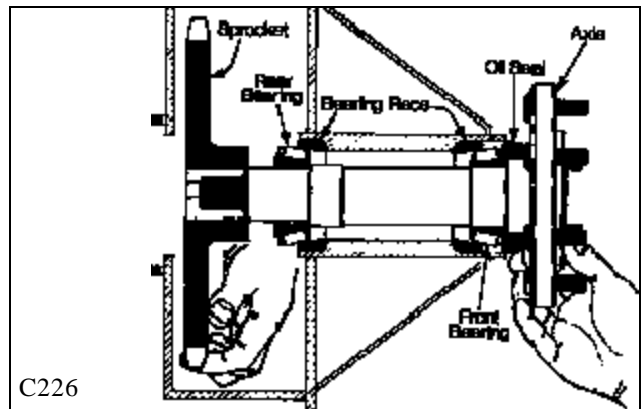
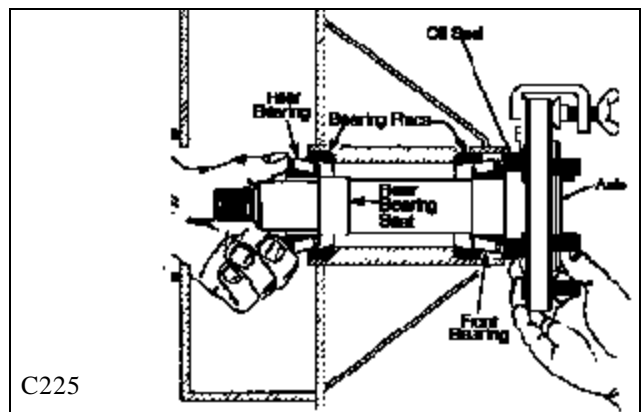
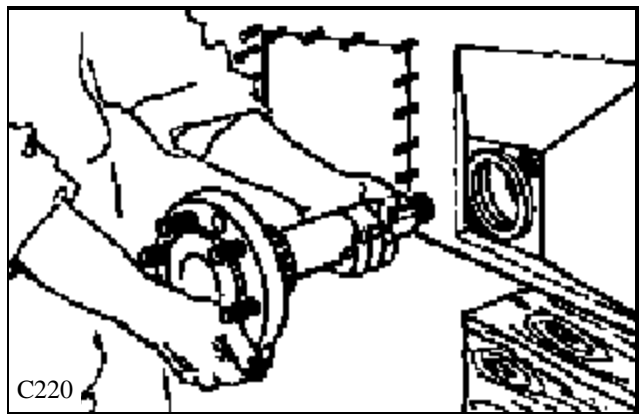
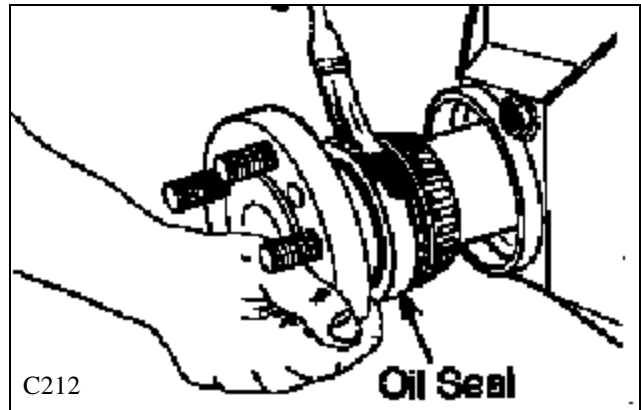

AXLE ASSEMBLY 3.5

Axle Installation (cont'd)

14 Place the axle washer and castle nut onto the threaded end of the axle. (fig. C2434) Lightly tap the face of the axle flange, while holding the sprocket in position, if necessary to get the axle washer on and the castle nut started.

15 Hold the axle from rotating and tighten the castle nut and guide the axle into the final drive housing as straight as possible to prevent damaging the seal. Tap the axle flange with a hammer if necessary to assist the installation.

As the castle nut is being tightened the rear (inside) bearing is being pressed into place and the axle oil seal is simultaneously pulled into the proper location into the final drive housing.

16 When the castle nut will not turn on any further tap the face of the axle flange with a hammer to ensure the seal, bearings and races have seated into place.

17 Remove the castle nut, axle washer and remove the axle oil seal installation tools.

18 Line up the axle and sprocket key ways and install the keys into the key way slots. (fig. C2435) Use a brass drift punch and hammer if necessary to install the keys into the key way slots. (fig. C2436).

19 Install the axle washer and castle nut. Tighten the castle nut to remove all axle bearing end play. (Zero pre-load). Continue tightening until the split pin hole in the axle will align with the castle nut slot.

20 Install the split pin. Bend both ends of the split pin straight back against the axle washer. (fig. C2431).

21 Install the axle cover using silicone to seal the matting surfaces. Do not over tighten the retaining nuts. 12 lbs/ft maximum. (16.5 nm).

22 Install the drive chain. Refer to Section 3.3.

23 Fill the final drive housing to the correct level using 10W30 API classification SE/ CD oil. Refer to Section 3.2 for procedure.

24 Install the inspection cover using silicone to seal the matting surfaces. Do not over tighten the retaining nuts. 12 lbs/ft maximum. (16.5 nm).

25 Install the wheels. Torque the wheel nuts to 100 to 110 lbs/ft. (135 to 149 nm).

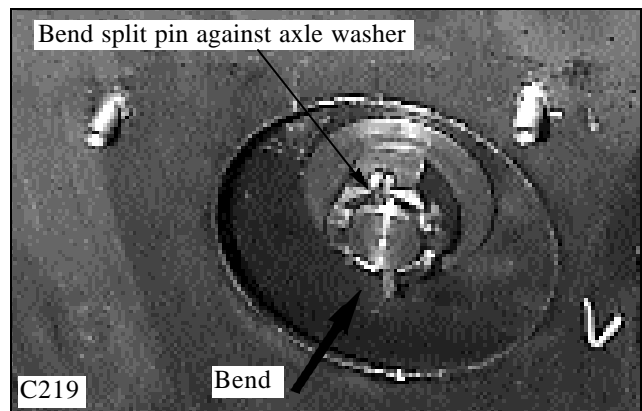
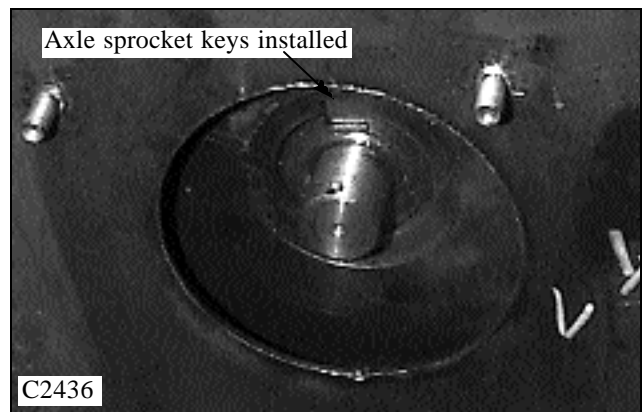
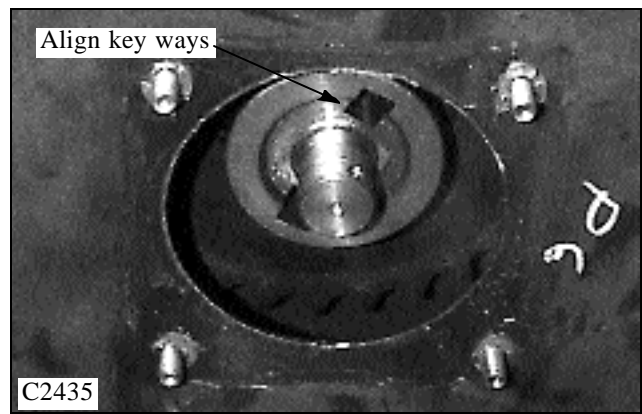

3

AXLE ASSEMBLY 3.5

Axle Stud Replacement

- 1 Lower the boom arms and shut off the engine.
- 2 Raise and block clear of the surface the loader side of the loader the wheel studs are to be changed on.
- 3 Remove the wheel the studs are to be replaced on.
- 4 Remove the damaged or broken stud by rotating the axle so the damaged stud is at the 12:00 o'clock position as shown in fig. C209. The axle "tower" is relieved, or notch, in this location to allow stud removal without removing the axle assembly.
- 2 Strike the stud with a hammer to remove from the axle flange. (fig. C209).
- 3 Place a new stud in position behind the axle flange. Line up the splines on the stud with the splines cut into the axle flange. (fig. C210).
- 4 Place a wheel nut on the stud and use it to draw the stud into place in the axle flange as you tighten it. (fig. C211)
- 5 Replace the wheel and torque the wheel nuts to 100 to 110 lbs/ft. (135 to 149 nm)

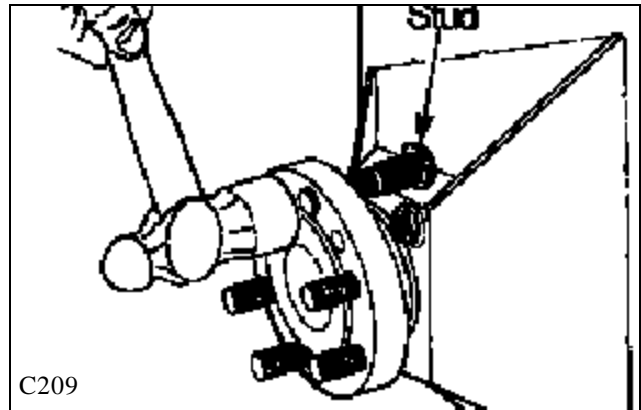

C209

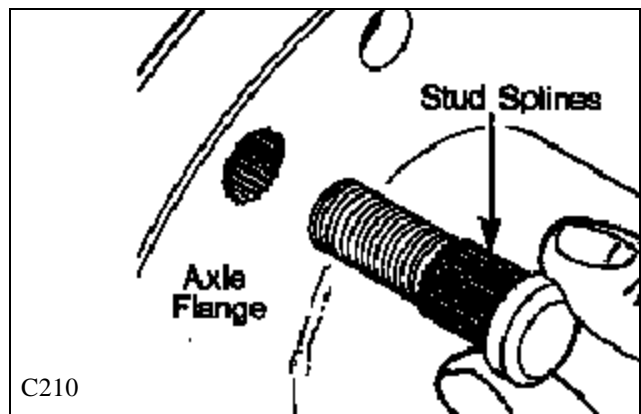

C210

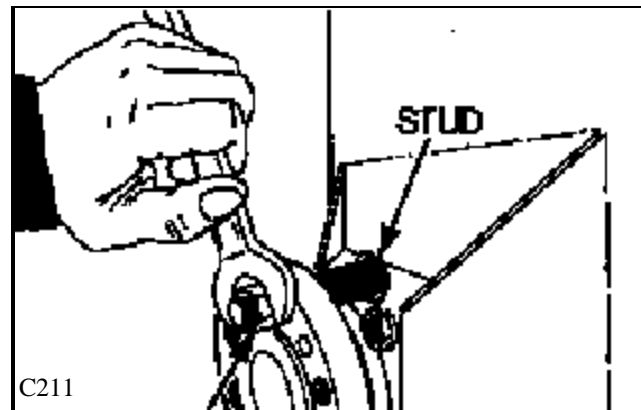

C211

IMPORTANT

Torque the wheel nuts daily to prevent stud and/ or wheel damage.



C1658



TROUBLE SHOOTING 3.6

3

Problem	Cause	Corrective Action	Section
Final drive noisy.	No lubricating oil.	Check oil level. Add 10W30 SE/CD oil to correct level.	3.2
	Chain is loose.	Adjust the chain tension. Check chain tension every 150 hours.	3.3
	Axle has too much end play. (Bearing pre-load)	Check and adjust the bearing pe-load on the axle bearings	3.6
	Chain tightener damage or failure.	Inspect the chain tightener and repair if necessary.	3.4
No drive on one side.	Drive chain failure.	Inspect the drive chain and connecting link. Replace damaged parts. Check the chain tension every 150 hours.	3.3
	Drive motor sprocket failure	Inspect the drive sprocket and splines. Replace parts as required.	3.5 2
	Drive motor or hydrostatic system failure	Refer to the hydrostatic drive section. Diagnose and make repairs as required.	2
Lubrication oil leaking through the filler / breather cap.	Lubricating oil level too high.	Check the oil level.	3.2
	Drive motor shaft seal leakage.	Inspect and repair damaged parts.	2
Wheel studs shearing off.	Wheel nuts loose.	Replace the wheel studs. Check wheel nut torque daily. Torque wheel nuts at 100 to 110 lbs/ft. (135 to 149 nm)	3.6
Wheel stud threads stripped.	Wheel nuts over tightened.	Replace the wheel studs. Check wheel nut torque daily. Torque wheel nuts at 100 to 110 lbs/ft. (135 to 149 nm)	3.6