

# SECTION 4 CONTROLS

<b>Steering</b>	<b>4.1</b>
Steering Control System Illustrations .....	pg. 4-2, 4-3
Neutral Detent Adjustment .....	pg. 4-4, 4-5
Neutral Adjustment .....	pg. 4-6
Tracking Adjustment (Speed) .....	pg. 4-7
Control Lever Replacement .....	pg. 4-8
<b>Foot Pedals</b>	<b>4.2</b>
Foot Pedal System Illustration .....	pg. 4-9
Cable Replacement .....	pg. 4-10
Angle Adjustment .....	pg. 4-11
Pedal Replacement .....	pg. 4-12
<b>Hand Controls</b>	<b>4.3</b>
Hand Control System Illustration .....	pg. 4-13
Cable Replacement .....	pg. 4-14
Angle Adjustment .....	pg. 4-15
Control Lever Replacement .....	pg. 4-16
<b>Throttle</b>	<b>4.4</b>
Throttle System Illustration .....	pg. 4-17
Adjustment .....	pg. 4-18
Throttle Cable Replacement .....	pg. 4-20
<b>Restraint Bar</b>	<b>4.5</b>
Restraint Bar System Illustration .....	pg. 4-21
Gas Spring Replacement .....	pg. 4-22
Restraint Bar Replacement .....	pg. 4-23
<b>Parking Brake</b>	<b>4.6</b>
General Information .....	pg. 4-24
<b>Trouble Shooting</b>	<b>4.7</b>
Steering Controls .....	pg. 4-25
Foot Pedals .....	pg. 4-25
Hand Controls .....	pg. 4-25
Restraint Bar .....	pg. 4-25



# STEERING 4.1

4

R.H. Control lever (Std)

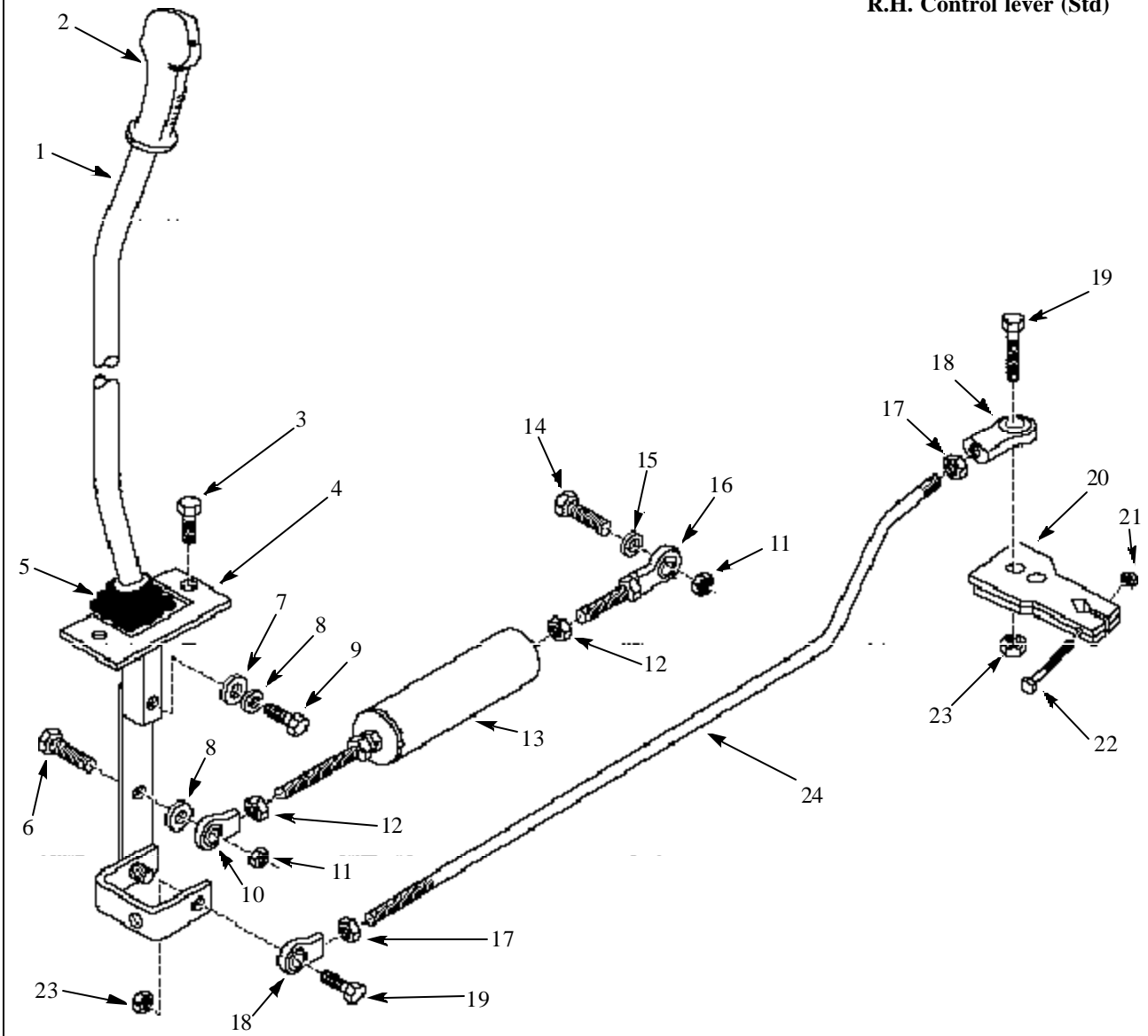

- 1 Control lever
- 2 Control handle
- 3 Screw
- 4 Bellows Cover
- 5 Bellows
- 6 Bolt
- 7 Flat washer
- 8 Lock washer
- 9 Bolt
- 10 Female Rod End
- 11 Lock Nut
- 12 Nut
- 13 Hydroback (\*)

- 14 Bolt
  - 15 Spacer Washer
  - 16 Male Rod end
  - 17 Nut
  - 18 Female Rod End
  - 19 Bolt
  - 20 Pintle Lever
  - 21 Lock Nut
  - 22 Bolt
  - 23 Lock Nut
  - 24 Control Linkage
- (\*) Includes items 10, 12, 13, & 16

C2944

# STEERING 4.1

L.H. Control lever (Std)

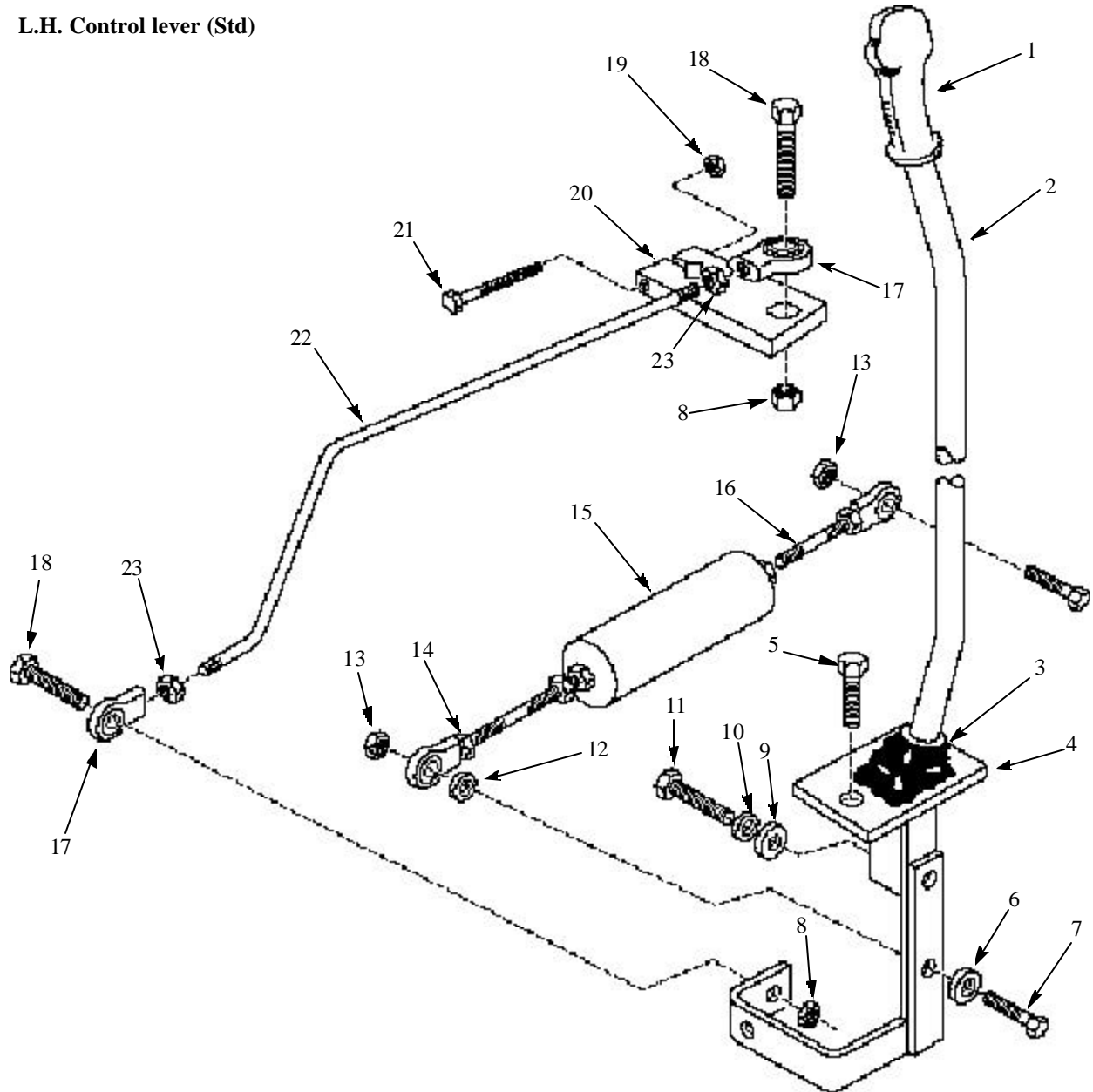

- 1 Control handle
- 2 Control lever
- 3 Bellows
- 4 Bellows Cover
- 5 Screw
- 6 Washer
- 7 Bolt
- 8 Lock Nut
- 9 Flat Washer
- 10 Lock Washer
- 11 Bolt
- 12 Spacer Washer

- 13 Lock Nut
- 14 Nut
- 15 Hydro back (\*)
- 16 Male Rod End
- 17 Female Rod End
- 18 Bolt
- 19 Lock Nut
- 20 Pintle Lever
- 21 Bolt
- 22 Control Rod
- 23 Nut

(\*) Includes items 10, 22, 25 & 26

C2943



# STEERING 4.1

# 4

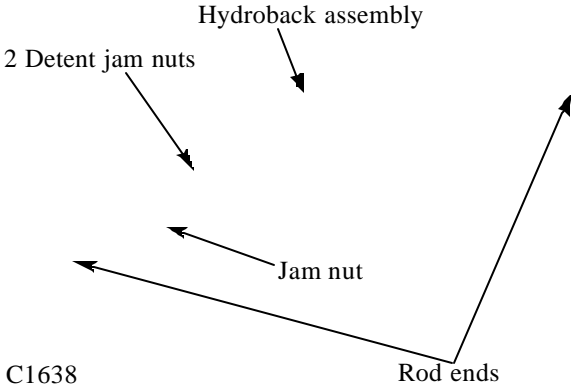
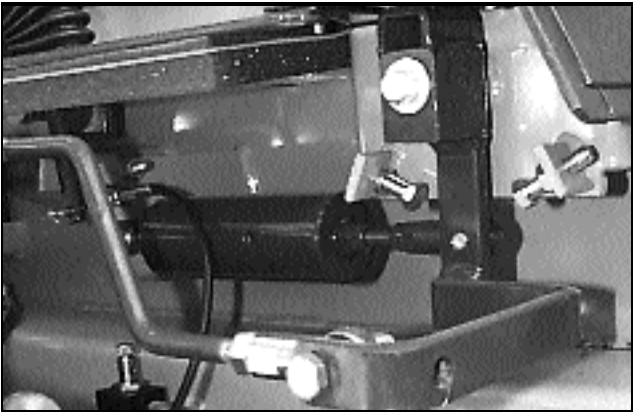

# STEERING 4.1

## Detent Adjustment (con't.)

- 6 Loosen the 2 jam nuts next to the main body. (fig. C1638, C2364)
- 7 Turn the 2 nuts away from the main body of the hydroback.
- 8 Cycle the control lever several times.
- 9 Push the control lever rearward until you feel resistance. Stop.
- 10 Turn the 2 jam nuts back toward the main body of the hydroback until the nut just touches the flat washer.
- 11 Cycle the control lever again checking for a positive “detent” feel. If you now have a positive neural, tighten the 2 jam nuts together. If the hydroback still does not center, the hydroback has internal damage or wear. Replace the hydroback assembly with a new one.

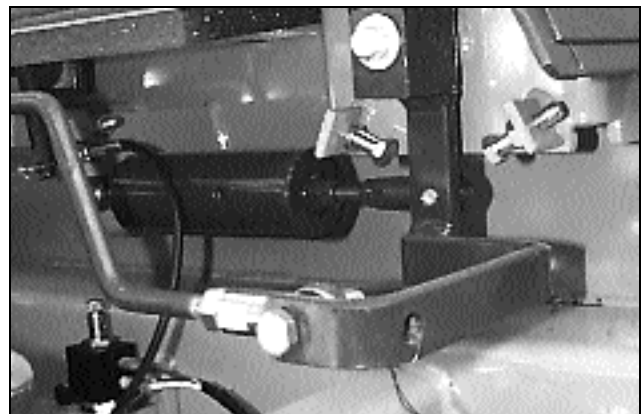
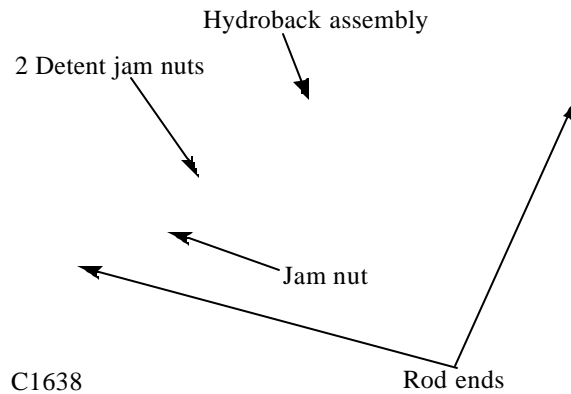

## Hydro Back Replacement

Replacing the hydro back changes the steering control lever angle. To correctly set the angle after the hydro back has been installed:

- 1 Replace the hydro back by removing the 2 bolts located at either end of the hydro back assembly.
- 2 Install the hydro back in the reverse order. Check the steering control rod ends and replace them now if they are worn.
- 3 Use an angle finder to check the base measurement angle the loader is sitting at. (fig. C2048) Note the angle the loader is sitting at. This measurement will have to be added or subtracted to the next measurement to give the most accurate adjustment.
- 4 Attach an angle finder to the most vertical part of the control lever. (fig. C2442)
- 5 Turn the hydro back threaded rod (fig. C2364) in or out of the female rod end to move the control lever to a reading of 9° leaning forward. Be sure to allow for angle the loader is sitting at. (Base angle) Jam the nut against the rod end when completed.

**Make sure there is a minimum of 3/8” (6mm) of thread holding the female rod end to the threaded rod.**

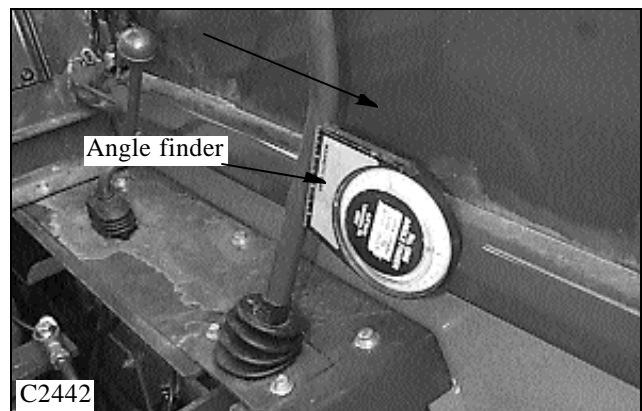
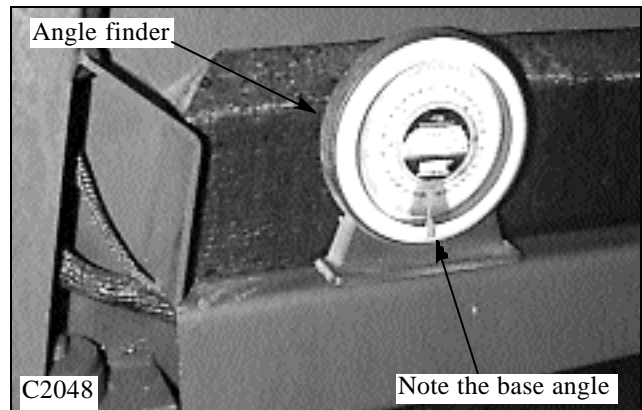

4

# STEERING 4.1

## Neutral Adjustment

Before performing the neutral adjustment make sure the neutral detent or hydro back is functioning and adjusted properly. Refer to page 4-4.

### IMPORTANT

If you are unfamiliar with the control operations of the loader, read the Owner's / Operator's Manual beforehand.

1 Raise the boom arms, engage the boom support pins and shut off the engine. Raise and block the loader securely off the ground.

### WARNING

Never work under the boom arms without the boom supports engaged.

2 Remove the seat and hydrostatic shield. Note the location of the steering control linkage. (fig. C2443, 2438a)

3 Check the control rod end bushings for wear. If any play is present between the bushings and the bolts replace the rod ends.

4 Check the pintle lever for tightness on the swash plate shaft. Tighten the clamping bolt or replace the pintle lever if required. (fig. C2359)

5 If and when all rod bushings and pivot points have been check for wear or binding, proceed with the neutral adjustment.

6 Loosen the jam nuts on the control rod linkage. (fig. C2438b)

7 Start the engine and release the parking brake. Note the direction the drive wheels are rotating.

8 Remove the bolt in one of the control rod ends and make adjustments by turning the rod ends and linkage to lengthen or shorten the linkage as required. Replace the bolt and tighten the jam nuts against the rod ends and recheck the neutral adjustment. Repeat if necessary.

**Maintain 3/8" (9mm) thread in rod end.**

9 Very fine adjustment can be made at the hydro back threaded rod. Adjustment here affects the control lever angle. **Only make minor adjustments using this method. Maintain 3/8" (9mm) thread in rod end.**

### WARNING

Repairs or adjustment to the control lever system may change the loader neutral position. Make sure the loader is raised securely off the ground before restarting the engine, or accelerated loader movement may result.

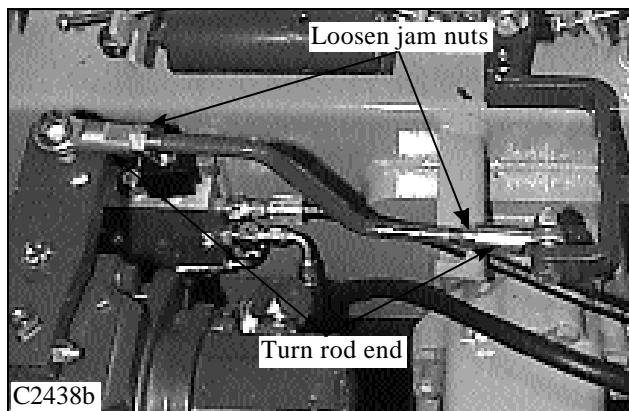
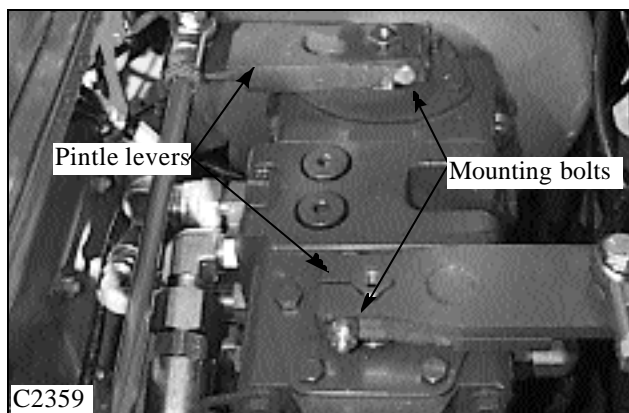
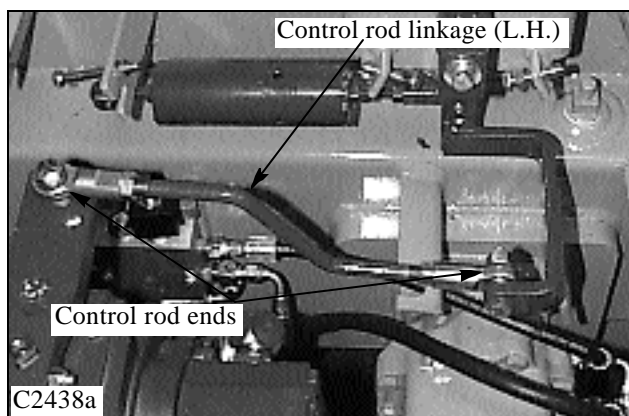
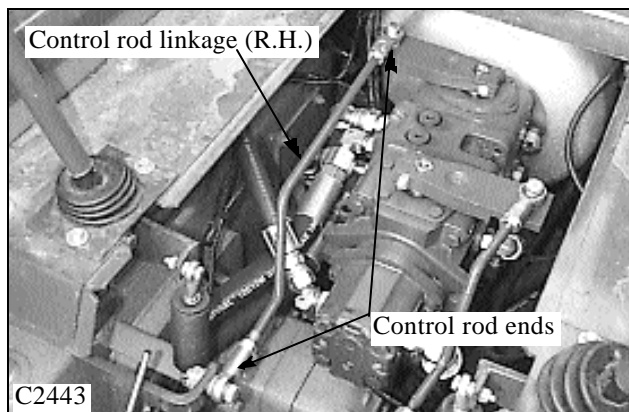

# STEERING 4.1

## Tracking Adjustment (Speed)

Tracking adjustment, or wheel speed, is set individually for L.H. and R.H. sides, forward and reverse. If the operator complains the loader does not go in a straight line when the levers are pushed clear forward the limiter stops may need adjustment.

1 Raise the boom arms, engage the boom support pins and shut off the engine. Raise and block the loader securely off the ground.

### WARNING

**Never work under the boom arms without the boom supports engaged.**

2 Remove the seat and hydrostatic shield. Note the location of the steering control limiter bolts located front and rear of each steering control lever, just below the pivot point. (fig. C2364).

3 Make sure the detent and neutral adjustments are adjusted correctly. Refer to pages 4-4 ~ 4-6.

4 If and when all rod bushings and pivot points have been check for wear or binding, proceed with the wheel speed adjustment.

5 Start the engine and release the parking brake. Adjust the engine RPM to the full high idle position. (3000 RPM) Refer to Section 7 to verify engine RPM.

### WARNING

**Raise the loader securely off the ground before starting the engine or accelerated loader movement may result.**

6 Using an RPM surface speed measuring tool (fig. C1837 Thomas P/N 43981), check wheel speed in the forward and reverse direction. Repeat for opposite side. (fig. C2445)

7 Correct wheel speed is set evenly at 82 RPM forward and reverse for both sides.

8 If adjustment is necessary, loosen the jam nut (fig. C2025) and turn the limiter bolt in to increase wheel speed or out to slow it down.

9 Tighten the jam nut and retest the speed adjustment. Repeat if necessary.

10 Replace the seat and hydrostatic shield.

**Note:** If the wheel speed does not meet the above specification, check the engine RPM. Refer to Section 7. If the engine RPM check out good you may need to check for hydrostatic problems such as drive motor seal leakage etc. Refer to Section 2 for testing procedures.

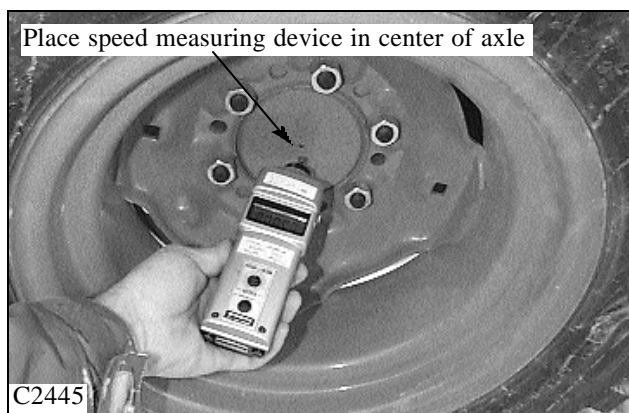
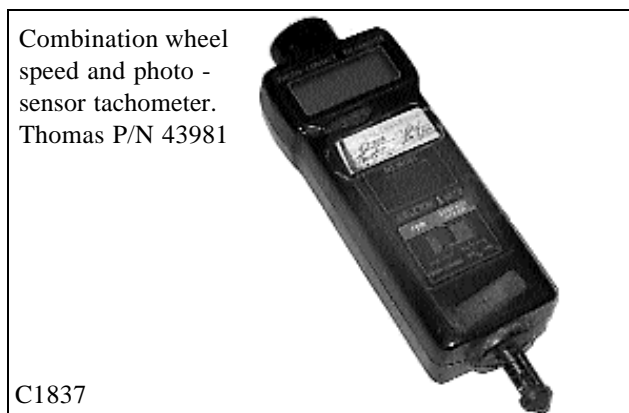
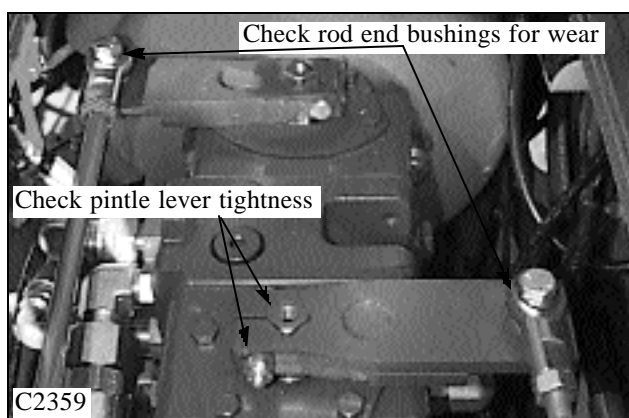
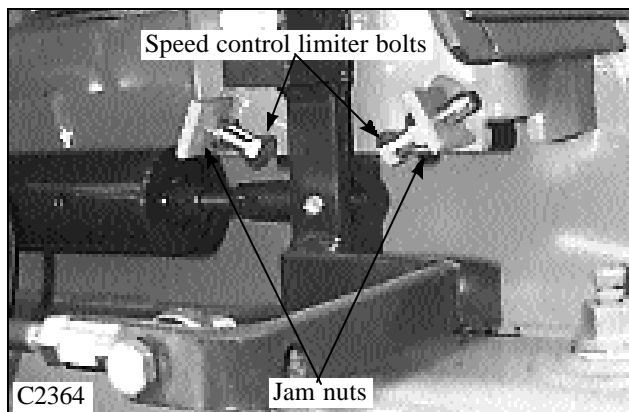

4

# STEERING 4.1

## Control Lever Replacement

1 Raise the boom arms, engage the boom supports and shut off the engine. Raise the loader securely off the ground to prevent accidental engagement of the drive functions upon restarting the engine.

### WARNING

Never work under the boom arms without the boom supports engaged.

- 2 Remove the seat and hydrostatic shield.
- 3 Remove the control handle by turning counter clock wise. (fig. C2948)
- 4 Remove the screws holding the bellows cover down. (fig. C2446) Slide the bellows over the top of the lever.
- 5 Remove the bolt going through the control rod and hydro back linkage. (fig. C2438a)
- 6 Remove the bolt and washers mounting the control lever to it's pivot point. (fig.C2438b) The control lever is now free to be removed.
- 7 Replace the control lever in the reverse order. Lightly lubricate the pivot shaft with white grease when assembling the control lever to the pivot shaft.
- 8 If necessary, make adjustments to the neutral centering and wheel speed as required. Refer to pages 4 - 4 ~ 4 - 7.

### WARNING

Repairs or adjustment to the control lever system may change the loader neutral position. Make sure the loader is raised securely off the ground before restarting the engine.

**Note:** If the loader is equipped with optional electrical accessories operated by control handle mounted switches, the control handle switch wiring will need to be disconnected and transferred to the new steering lever.

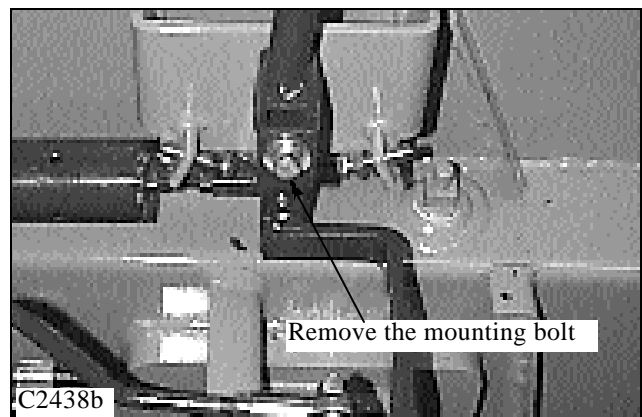
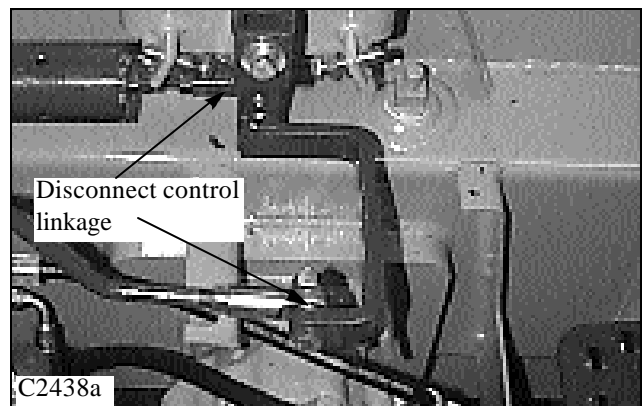
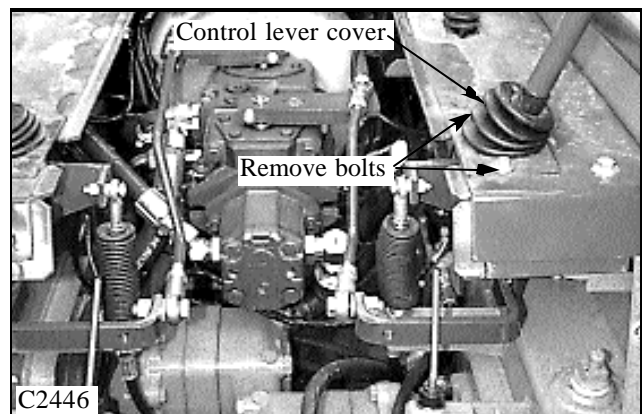
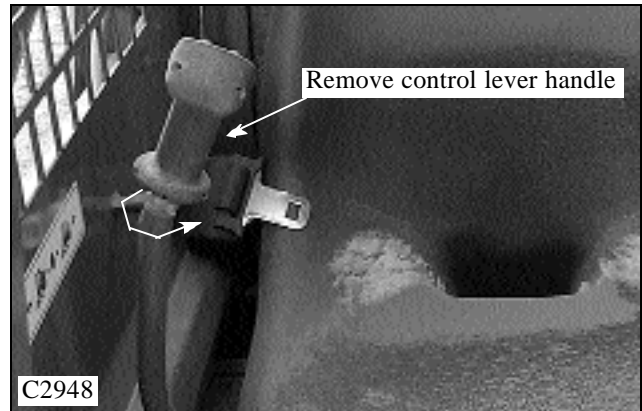



# FOOT PEDALS 4.2

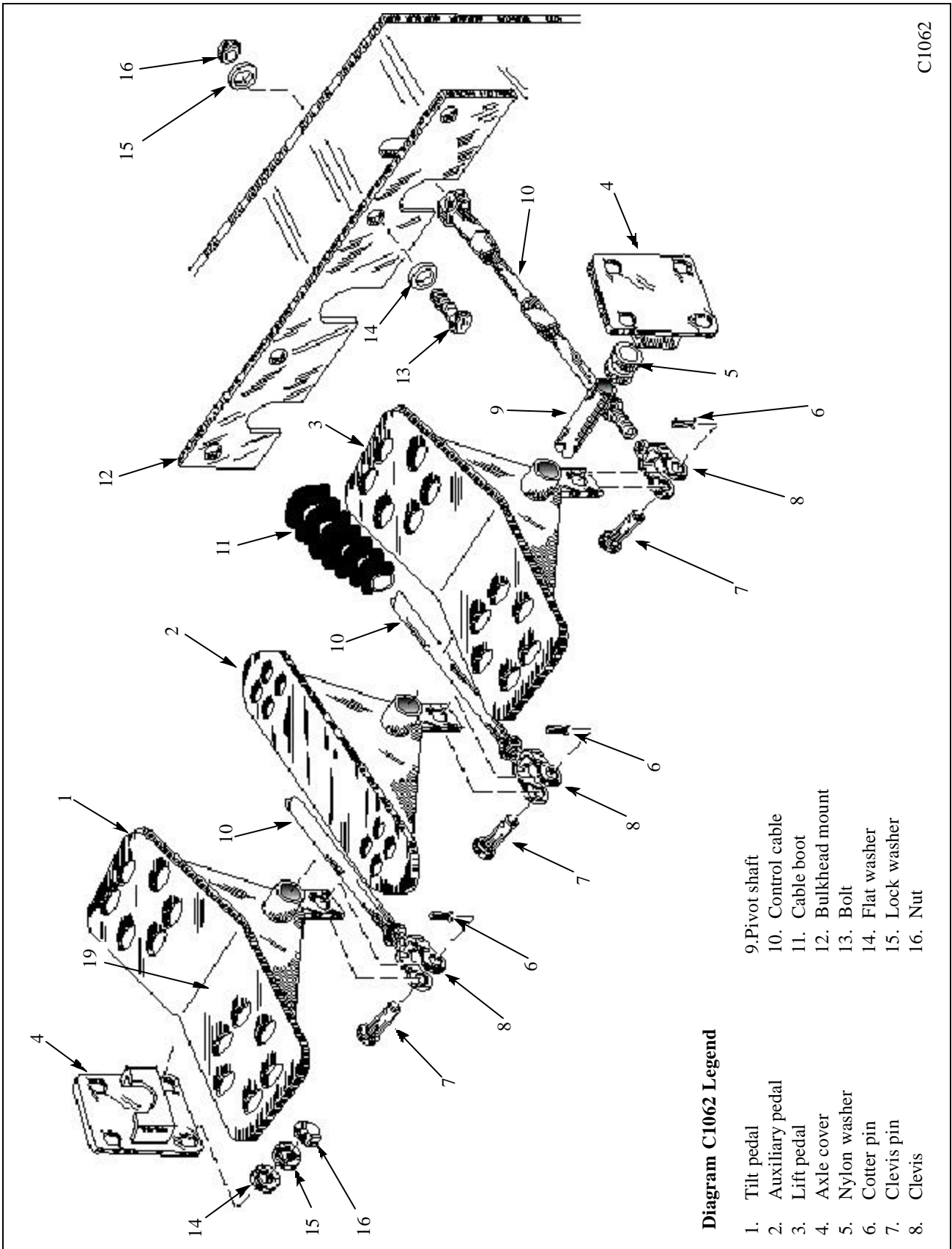

# FOOT PEDALS 4.2

## Cable Replacement

Check cable ends, eyelets or rod ends, and mounting pins for wear before removing the cable. Replace worn parts when replacing new cables. Cable ends should be inspected every 150 hours of operation.

- 1 Raise the boom arms, engage the boom supports and shut off the engine.

### WARNING

**Never work under the boom arms without the boom supports engaged.**

4

- 2 Remove the seat and hydrostatic shield.
- 3 Loosen the jam nuts on the cable clevis ends. (fig. C2440, C2367)
- 4 Loosen the cable nuts. (fig. C2439, C2367)
- 5 Remove the bolts retaining the bulk head mount to the frame plate. (fig. C2439)
- 6 Remove the cotter pins from both ends of the cables and remove the clevis pins. (fig. C2440, C2367)
- 7 Remove the cable.
- 8 Remove the clevis and eyelet ends of the cable and reuse them if still serviceable.
- 9 Install the new cable in the reverse order above. There must be a minimum of 3/8'' (6mm) of thread engagement into the cable clevis and eyelet ends.

**Note:** After installation of a new cable, the foot pedal angle will need to be verified and adjusted if necessary. Refer to page 4-11.

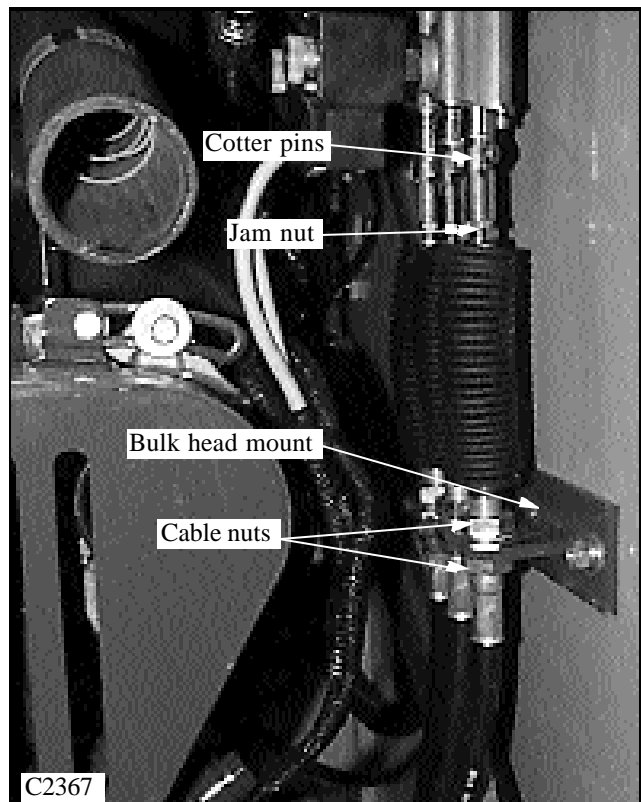
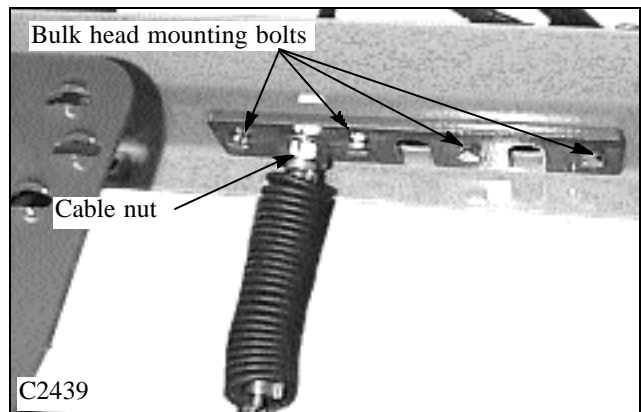
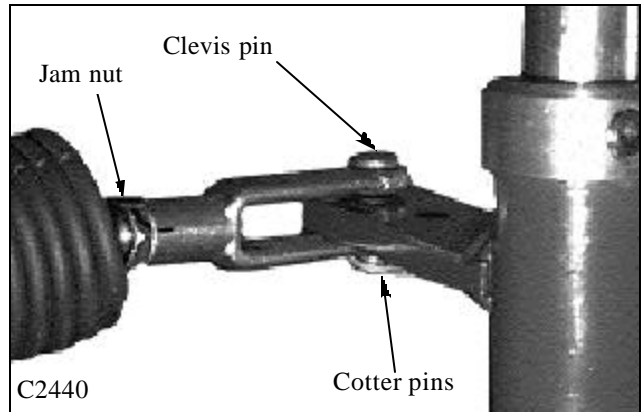

# FOOT PEDALS 4.2

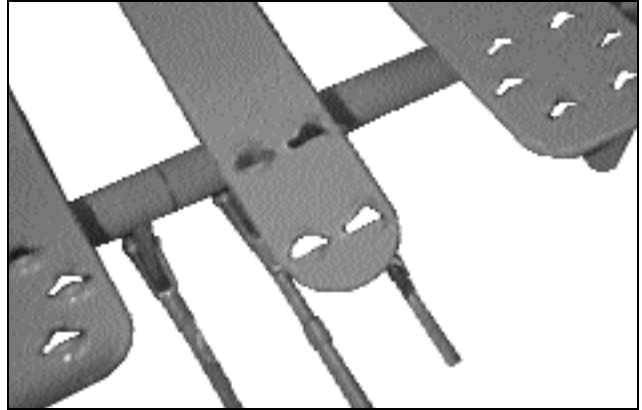

Checking the base angle

Angle finder

C2048



# FOOT PEDALS 4.2

4

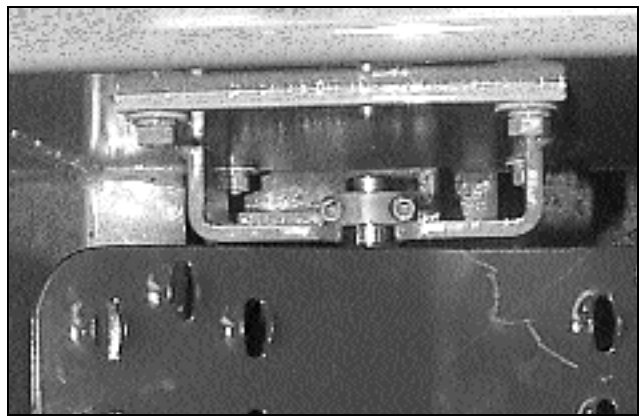
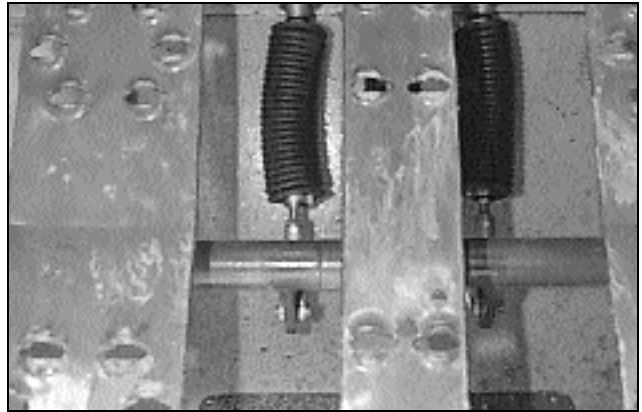

Pedal removal

Spacer washers

C2281

# HAND CONTROLS 4.3

Hand Operated Control Lever (L.H. Shown)

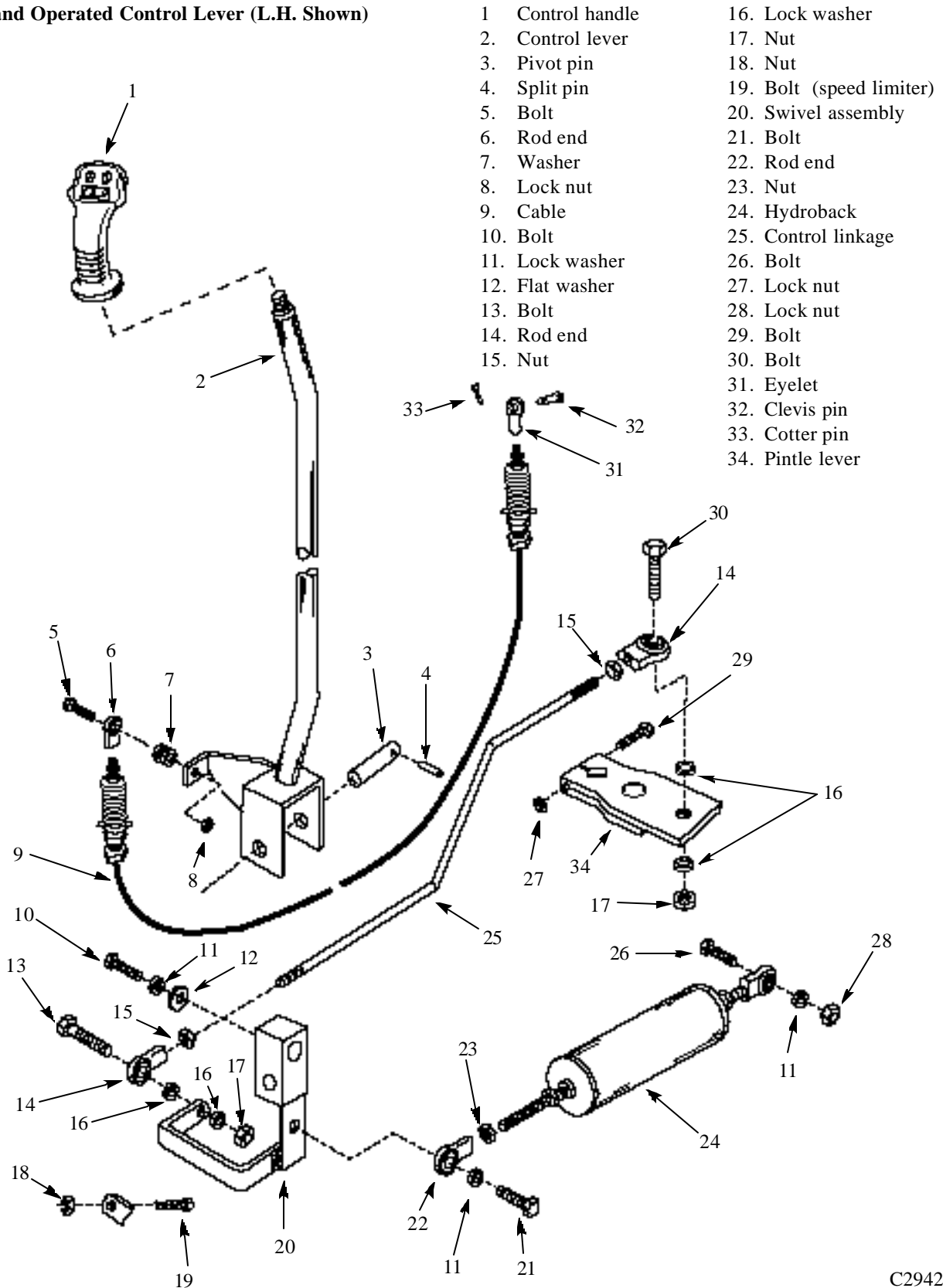

C2942

# HAND CONTROLS 4.3

## Cable Replacement

Check cable ends, eyelets or rod ends, and mounting pins for wear before removing the cable. Replace worn parts when replacing new cables. Cable ends should be inspected every 150 hours of operation.

- 1 Raise the boom arms, engage the boom supports and shut off the engine.

### WARNING

Never work under the boom arms without the boom supports engaged.

4

- 2 Remove the seat and hydrostatic shield.
- 3 Loosen the jam nuts on the cable rod end and eyelet end. (fig. C2020, C2034)
- 4 Loosen the cable nuts. (fig. C2448, C2367)
- 5 Remove the cotter pins from control valve end of the cable and remove the clevis pins. (fig. C2022)
- 6 Remove the cable.
- 7 Remove the clevis and eyelet ends of the cable and reuse them if still serviceable.
- 8 Install the new cable in the reverse order above. There must be a minimum of 3/8" (6mm) of thread engagement into the cable rod end and eyelet ends.

**Note:** After installation of a new cable, the control lever angle will need to be verified and adjusted if necessary. Refer to page 4-15.

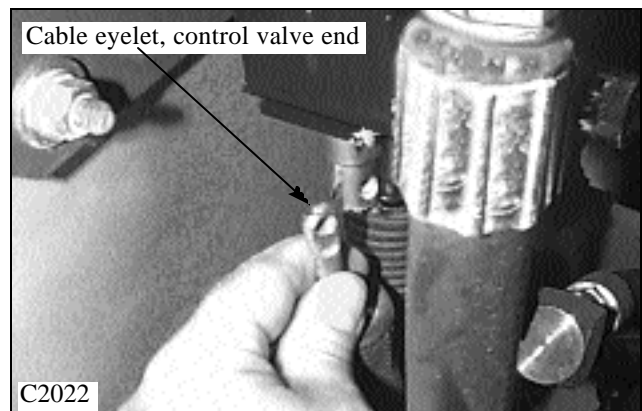
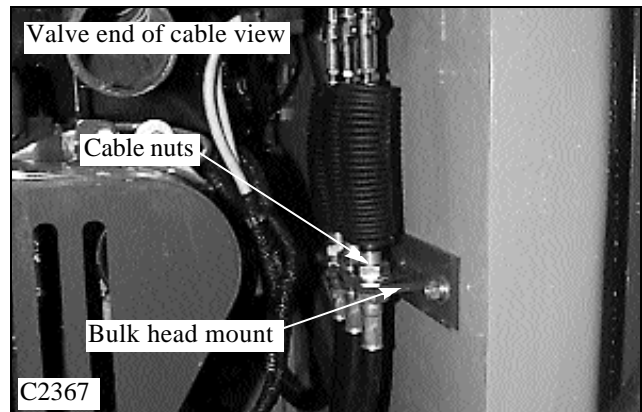
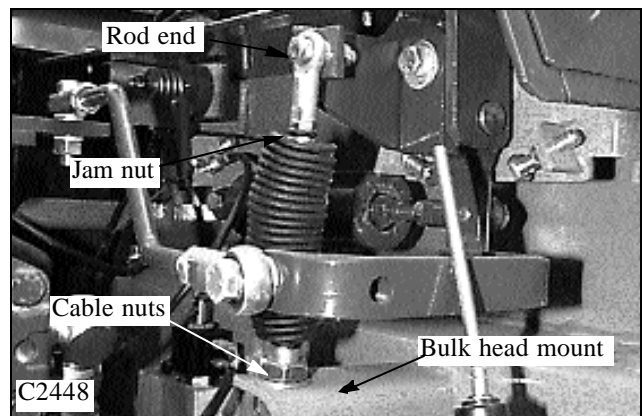
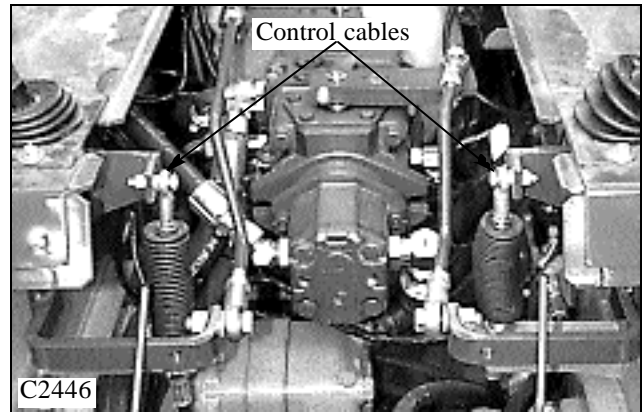

# HAND CONTROLS 4.3

## Angle Adjustment

After changing the control cable the control lever angle will need to be verified and / or adjusted to provide operator comfort and proper pedal travel clearance.

- 1 Make sure the cable ends are screwed onto the cable threads a minimum of 3/8" (6mm).
- 2 Place an angle finder on the fender of the loader to find the base measurement. Note the reading. (fig. C2049)
- 3 Place the angle finder on the control lever as shown in fig. C2449. Note the reading. The correct angle is 18° + / - 1°.

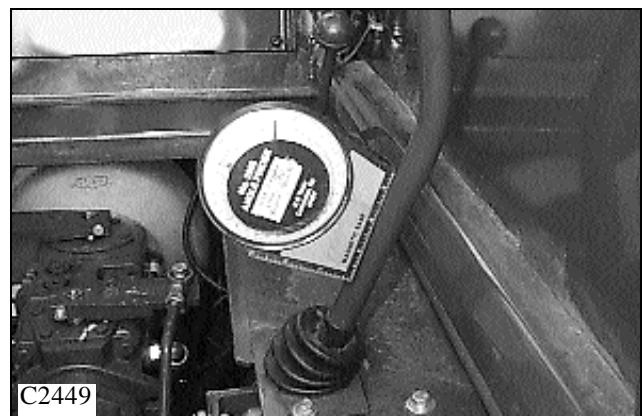
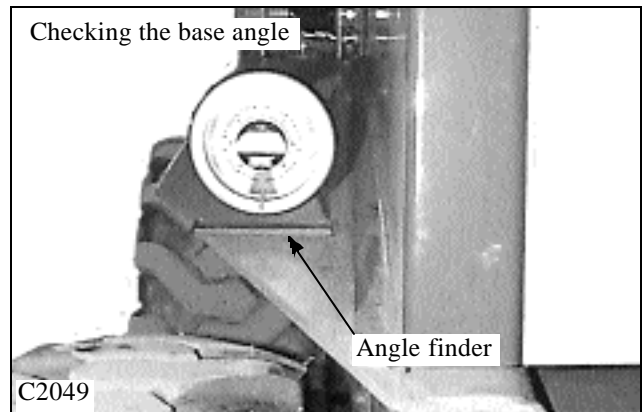

- 4 Adjust the angle by moving the cable nuts up or down on their mount. Adjustment may be made at the front and / or the rear of the cable. (fig. C2448, C2367) Be sure to allow for the base angle, the angle the loader may be leaning at while measuring. Add or subtract this measurement as necessary.

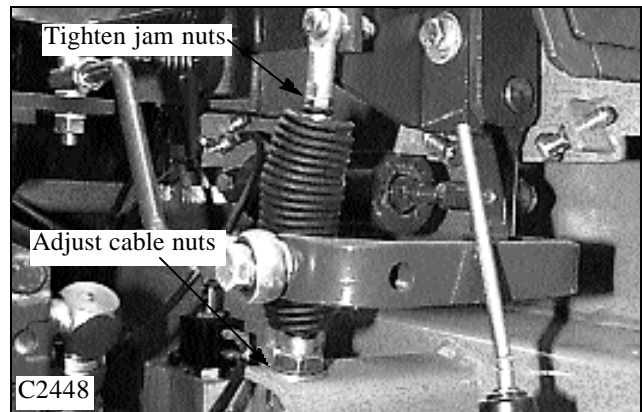

- 5 Tighten all cable nuts and jam nuts on the cable ends. (fig. C2448, C2367)

- 6 Cycle the control levers to check for travel clearance. Be sure controls return freely to the center position and the control locks engage positively.

- 7 Replace the seat and hydrostatic shields.

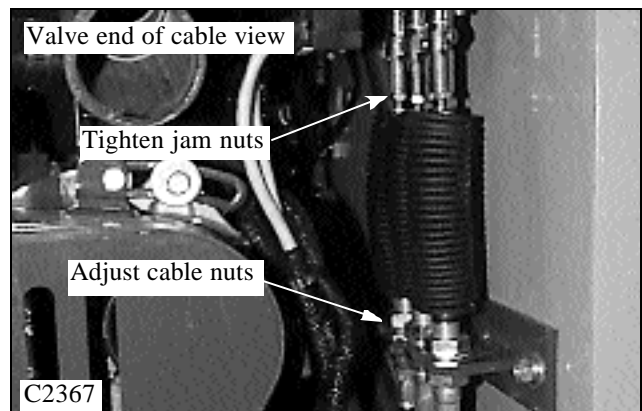

4

# HAND CONTROLS 4.3

## Control Lever Replacement

1 Raise the boom arms, engage the boom supports and shut off the engine.

### WARNING

**Never work under the boom arms without the boom supports engaged.**

- 2 Remove the seat and hydrostatic shield.
- 3 Remove the control handle from the steering lever by turning it counter clockwise. (fig. C2948) The handle may be reused on the new or repaired control lever.
- 4 Remove the bellows cover screws (fig.C2450) and remove the bellows.
- 5 Remove the bolt from the control cable to the swivel assembly. ( fig. C2447)
- 6 Remove the bolt from the control rod and hydro back linkage. (fig. C2447)
- 7 Remove the bolt from the swivel assembly and remove the control lever assembly. (fig. C2047)

**Note:** If the loader is equipped with optional electrical accessories operated by control handle mounted switches, the control handle switch wiring will need to be disconnected and transferred to the new steering lever. If the control lever functions are sloppy due to excessive wear of the swivel bushing, the swivel assembly may be replaced.

**See fig. C1201 page 4-13 for exploded view of control lever assembly.**

- 1 Remove the roll pin in the swivel shaft.
- 2 Remove the swivel shaft. Use a brass drift punch and hammer if necessary.
- 3 Save any spacer washers that may have been used.
- 4 Replace the swivel assembly.

Replace all parts in the reverse order. Use the spacer washers to remove the fore and aft movement of the steering lever on the swivel assembly. Use a new roll pin when installing the swivel shaft.

Install the control lever assembly to the loader in the reverse order of removal.

Cycle the control lever after installation to check for binding and travel clearance.

Check the control lever angles. Pages 4-5 and 4-15.

Check the wheel speed, or tracking, to assure optimum performance. Page 4-7.

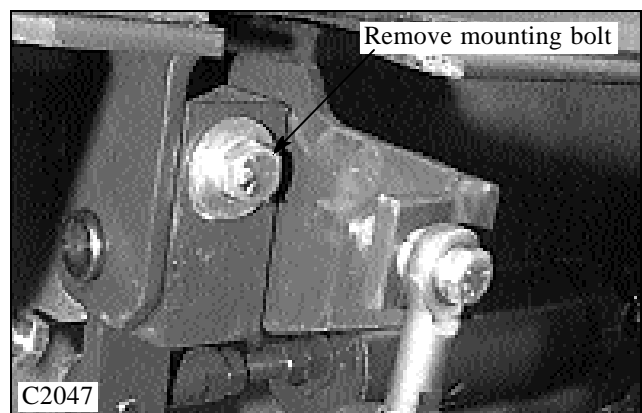
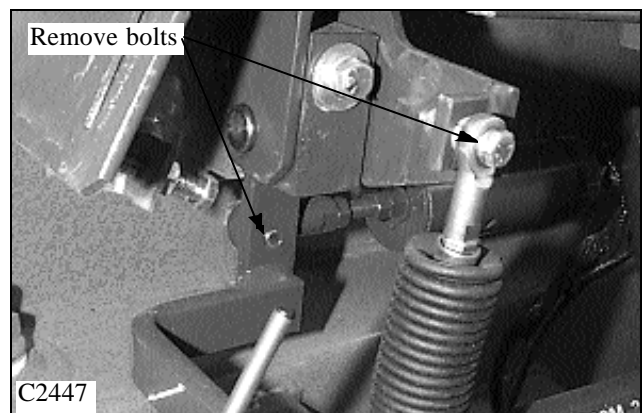
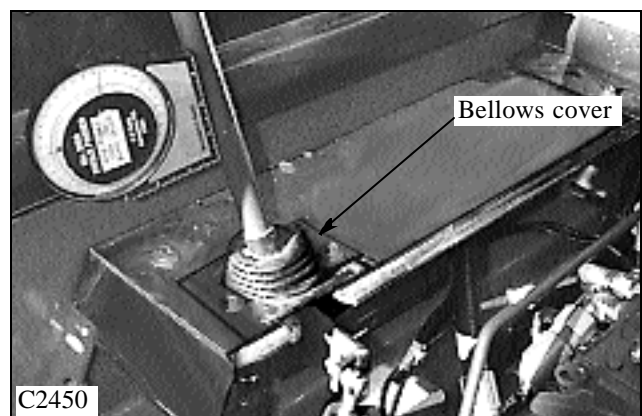
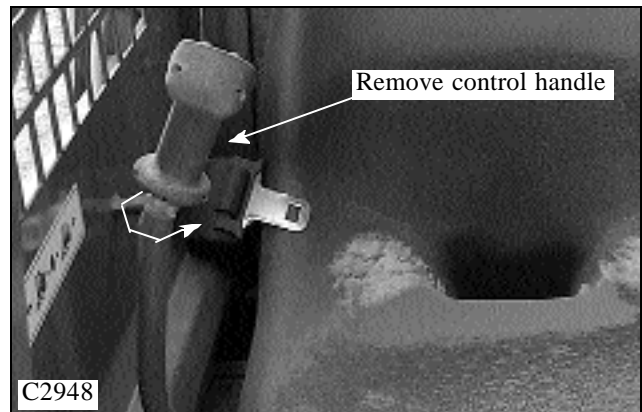

4



# THROTTLE 4.4

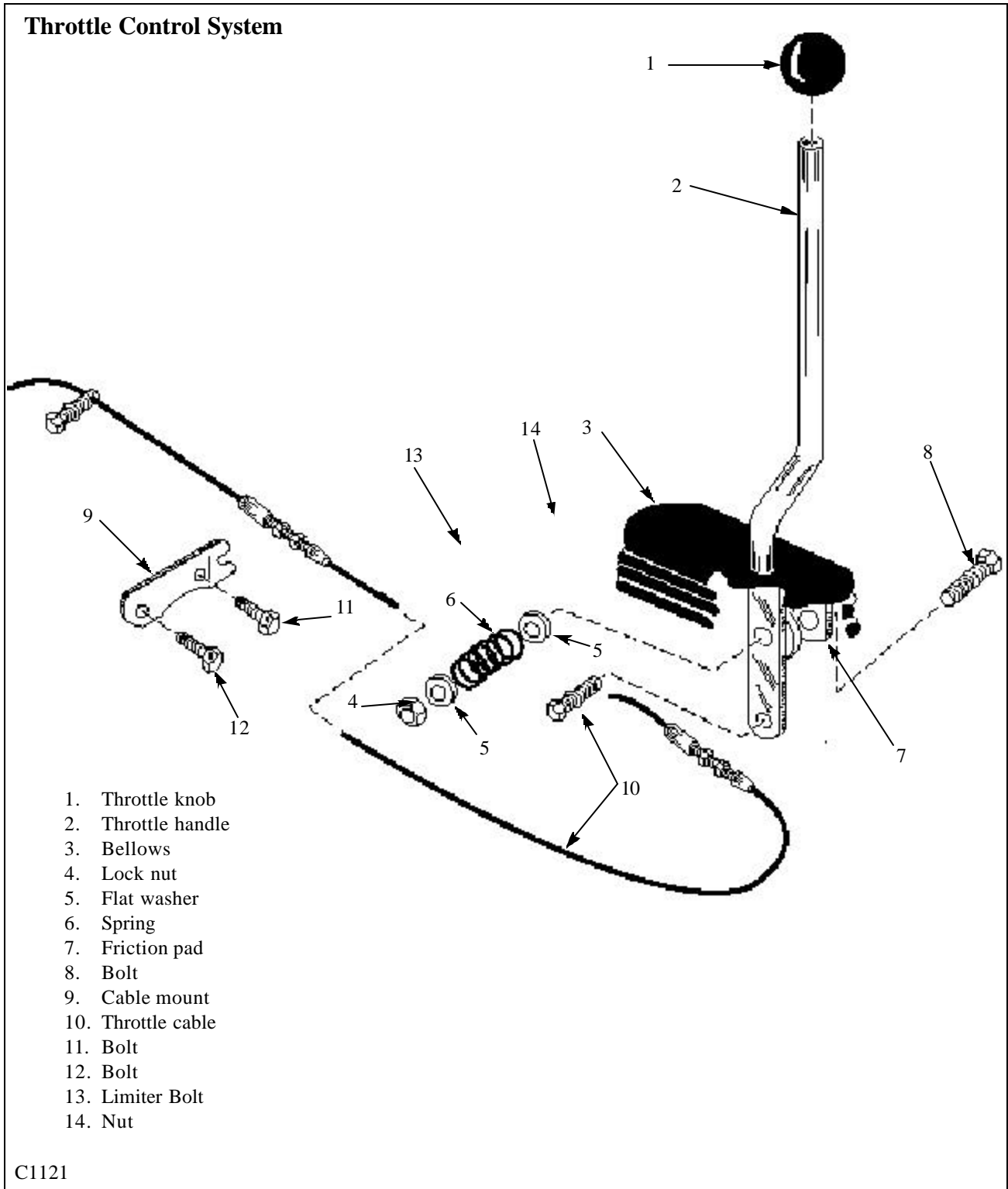

4

# THROTTLE 4.4

## Adjustments

The throttle system can be adjusted for tension and total travel. (stroke)

If the throttle system can not maintain a constant, steady, engine speed then the throttle handle tension spring may need to be adjusted.

- 1 Raise the boom arms, engage the boom supports and shut off the engine.

### WARNING

**Never work under the boom arms without the boom supports engaged.**

# 4

- 2 Remove the seat and hydrostatic shield.
- 3 Locate the throttle handle pivot and tension spring under the left hand cover plate. (fig. C2359, C2363)
- 4 Tighten the nut on the tension spring clock wise to increase the spring tension to gain clamping force against the friction pad.

**If this fails to repair the problem then the friction pad may need to be replaced.**

To check the throttle travel:

- 1 Open the rear door and locate the engine lever and throttle control cable.
- 2 Stroke the throttle lever in the full forward position. (C2451) The engine lever must touch the limiter bolt stops to acquire full engine speed. (fig. C2625)
- 3 Stroke the throttle lever rearward until it stops. The engine lever should touch the limiter bolt to acquire the engines proper low idle speed.
- 4 Adjust the set collars on either side of the engine lever and throttle linkage to get the full range of required travel for the engine lever to touch the limiter bolts.

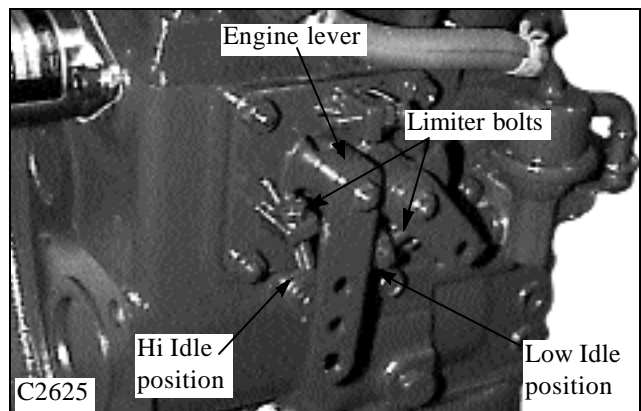
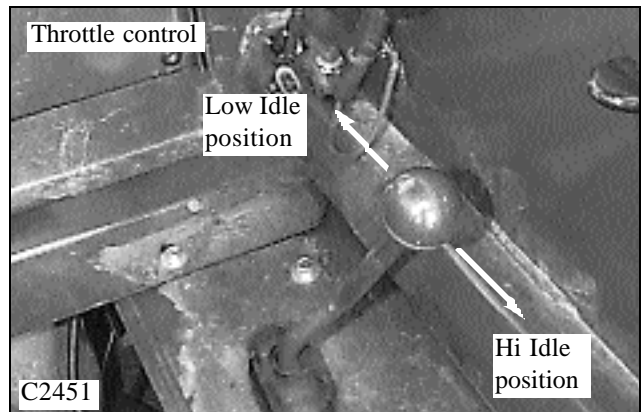
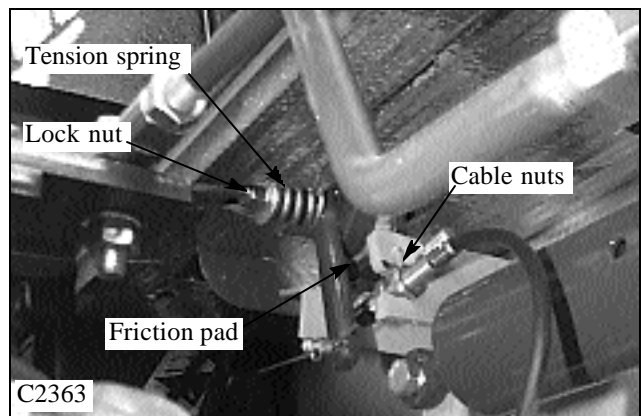
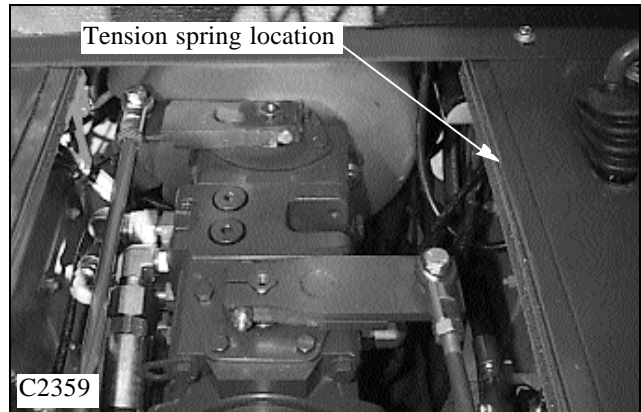

# NOTES



4

# THOMAS

# THROTTLE 4.4

## Throttle Cable Replacement

1 Raise the boom arms, engage the boom supports and shut off the engine.

### WARNING

Never work under the boom arms without the boom supports engaged.

2 Remove the seat and hydrostatic shield. (fig. C806).

3 Loosen the set screw connecting the throttle cable to the throttle handle. (fig. C2363). Loosen the mounting nuts.

4 Open the rear door and loosen the set screw connecting the throttle cable to the engine lever. (fig. C2626). Loosen the mounting nuts.

5 Remove the throttle cable.

6 Replace the throttle cable in the reverse order above.

7 Adjust the cable as outlined in section 4.4 so the engine lever bumps the limiter bolts (fig. C2625) when the throttle lever is stroked full ahead (high idle) and full rearward (low idle).

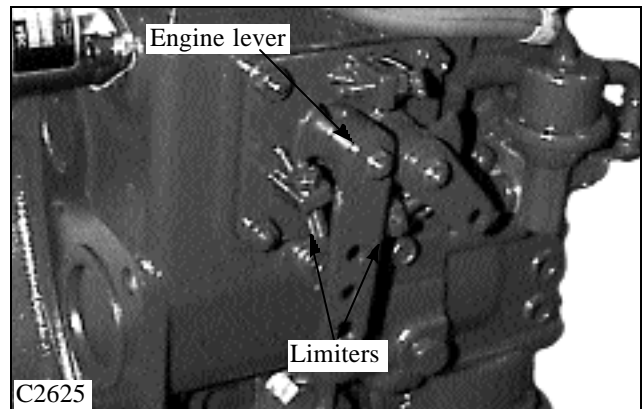
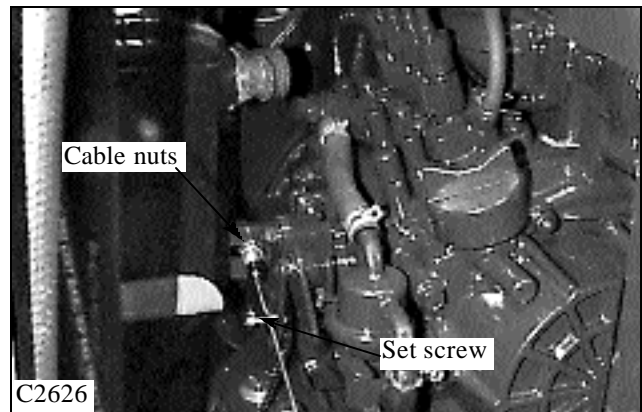
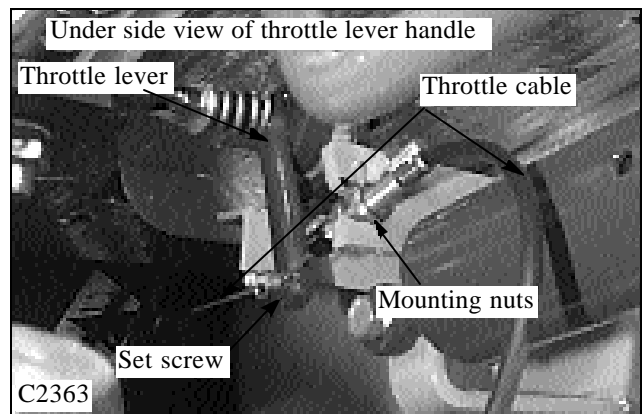
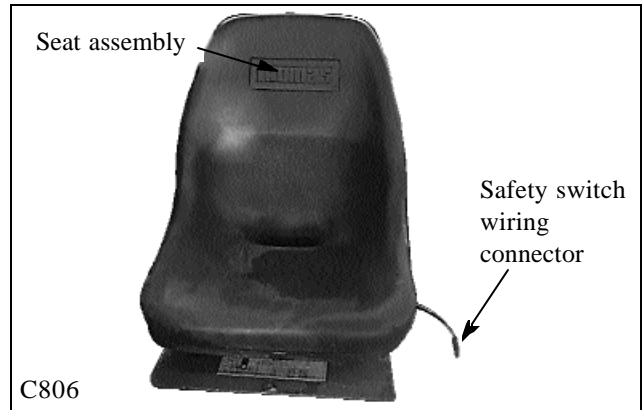

4

# RESTRAINT BAR 4.5

Restraint Bar System

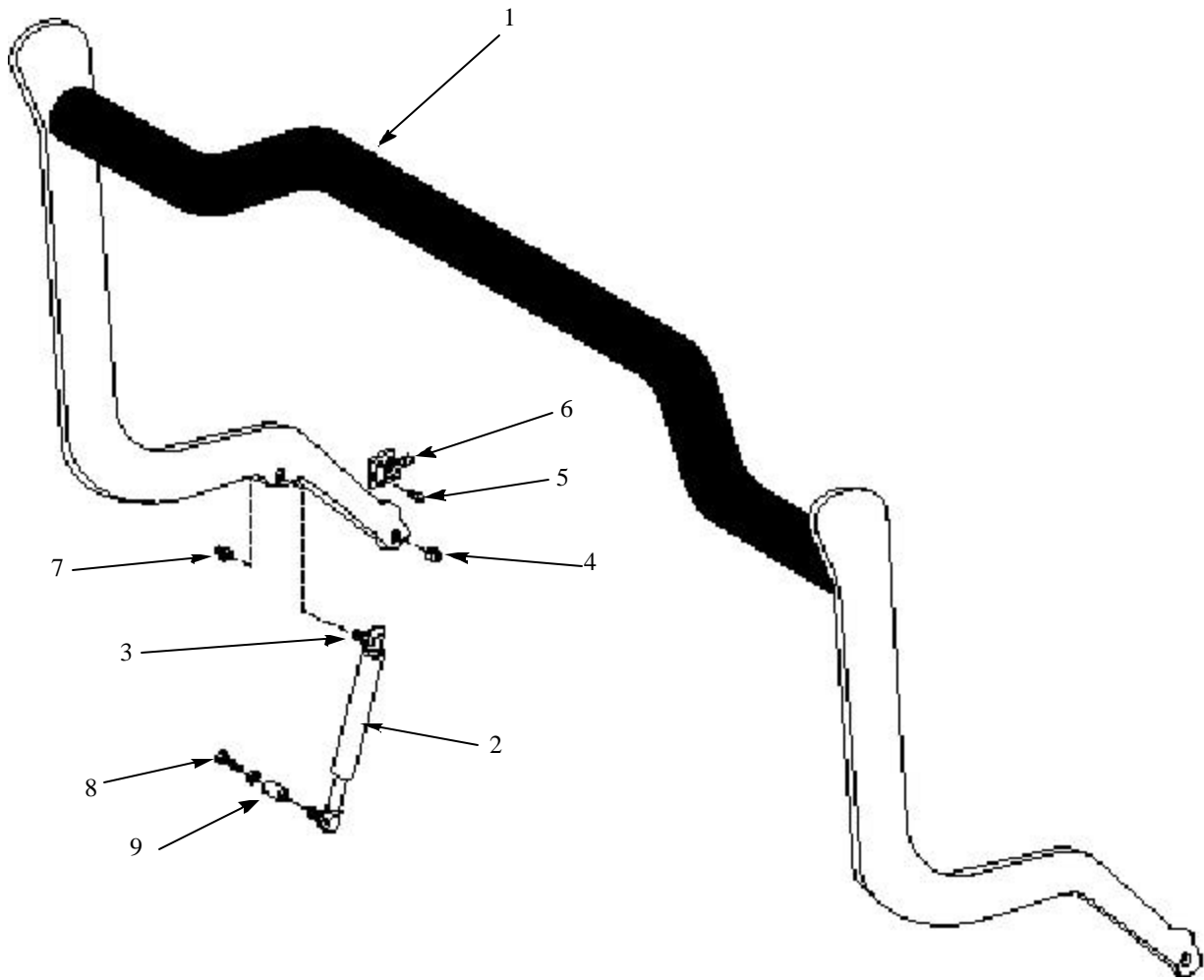

1. Restraint bar assembly
2. Gas spring
3. Ball stud
4. Lock nut
5. Stove bolt
6. Switch
7. Lock nut
8. Bolt
9. Spacer

C1014

4

# RESTRAINT BAR 4.5

## Gas Spring Replacement

The restraint bar is held up, over head, by means of a gas assist type strut. (gas spring)

If the seal in the strut has deteriorated and failed, or the strut rod has been damaged, the restraint bar will not stay in the upright position due to gas pressure loss.

To replace the gas spring assembly:

1 Lower the liftarms and park the loader on a level surface. Shut off the engine.

2 Insert a small flat bladed screwdriver behind the spring clips (fig. C2042) on either end of the gas spring. Twist the screw driver while pulling out on the gas spring. Repeat for the opposite end.

3 Check the ball pivot mounts for wear or damage. (fig. C2043) Replace them if necessary.

4 The new gas spring is fully charged and is extended to full length when installed. (fig. C2044)

5 Push one end of the gas spring onto the ball pivot mount.

6 Raise the restraint bar and attach the opposite end.

7 Cycle the restraint bar to verify the new gas spring will hold the restraint bar in the upright position.

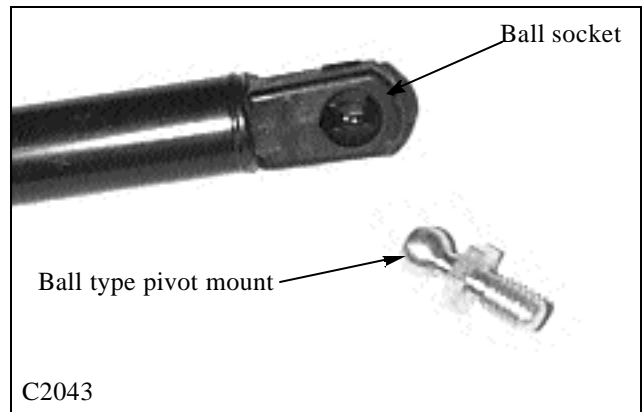
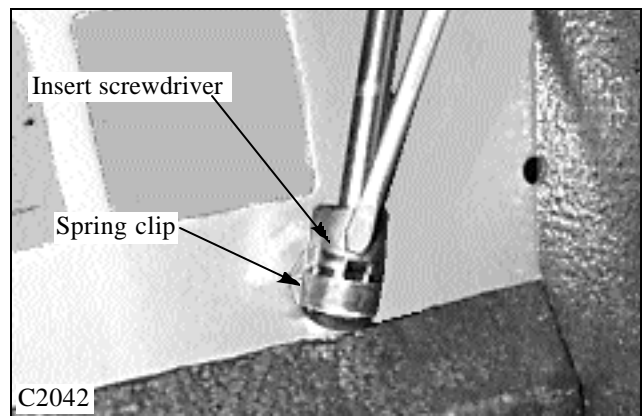
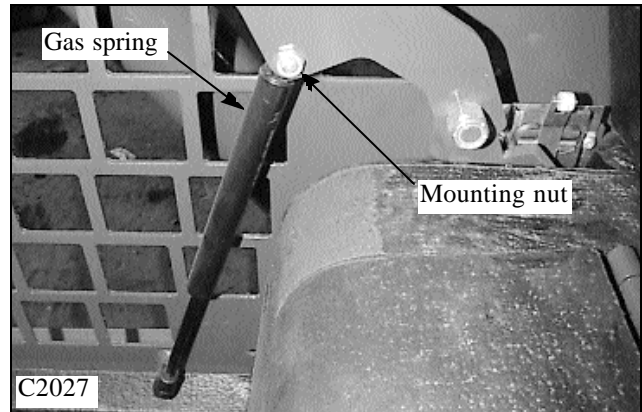

4

# RESTRAINT BAR 4.5

## Restraint Bar Replacement

1 Lower the liftarms and park the loader on a level surface. Shut off the engine.

2 Remove the nut from the upper gas spring pivot ball. (fig. C2936, C2027) Remove the mount and gas spring together allowing the restraint bar to lower.

3 Remove the 2 restraint bar mounting nuts. (fig. C2027) There is one on either side of the restraint bar.

4 Squeeze the restraint bar ends inward and remove each side from it's pivot / mounting bolt. Use caution, do not damage the safety switch located to the right rear of the restraint bar.

5 Replace the restraint bar in the reverse order. Use new lock nuts on the restraint bar mounts. Tighten to remove slack between the restraint bar and spacer bushings. Do not over tighten. The restraint bar should cycle freely up and down without binding.

6 Re- attach the upper ball pivot mount to the restraint bar. Cycle the restraint bar to check proper operation.

7 Check to make sure the safety switch is contacting the restraint bar, and functioning properly. This safety switch activates the parking brake when the engine is operating, the operator is seated with the seat belt fastened, and the restraint bar is in the raised position. Lower the restraint bar to release the parking brake.

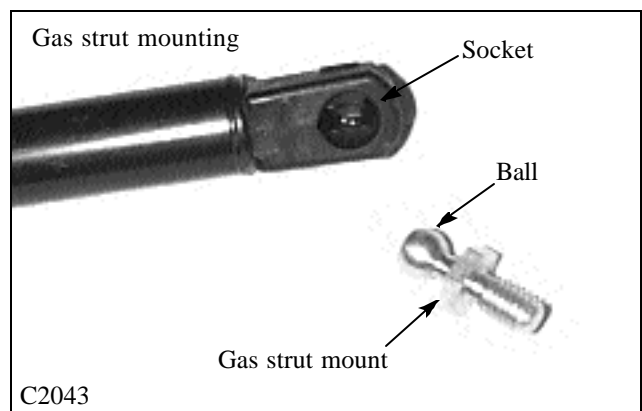
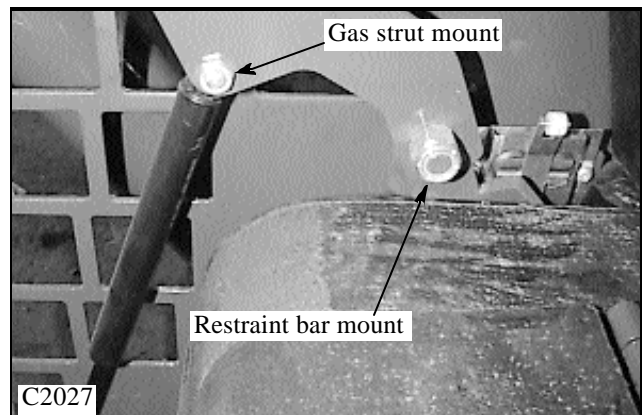
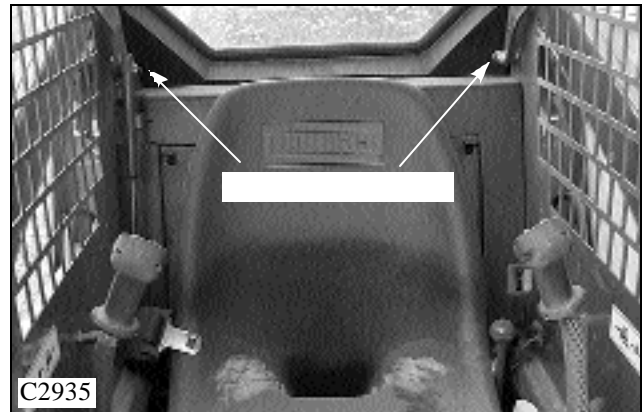

4

# PARKING BRAKE 4.6

## General Information

Each drive motor contains a set of clutch pack type friction discs that are spring loaded in the engaged position. The parking brake will only release when the clutch pack receives hydraulic pressure to separate the discs.

The parking brake system requires 200 psi (13.78 bar) hydraulic pressure to release or separate the clutch packs in the drive motors. The hydraulic pressure is provided by the charge pressure relief valve in the hydrostatic tandem pump.

The parking brake is inter locked with various safety switches. (fig. C807, C1816, C2362, C2027) The parking brake will only release when the engine is operating, the operator is seated with the seat belt fastened and the restraint bar is in the lowered position.

The parking brake may also be equipped with an optional push button switch located on the front left down tube of the ROPS. (fig. C1106)

When the engine is operating and all safety switches are functioning and in the closed position, the hydraulic / electric solenoid brake valve (fig. C2362) will allow charge pressure to release the parking brake in the drive motors.

4

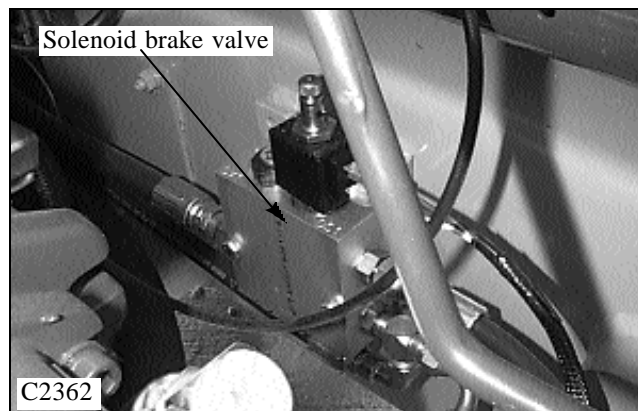
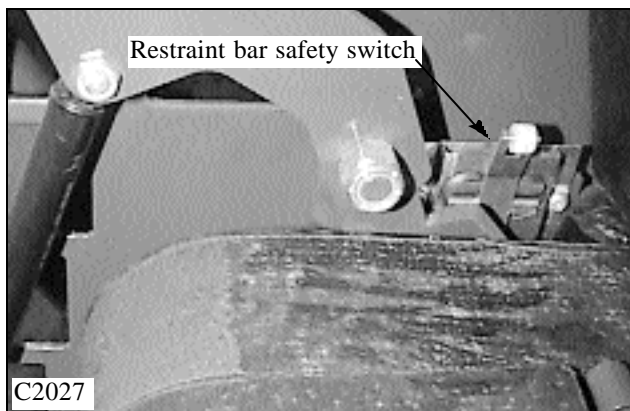
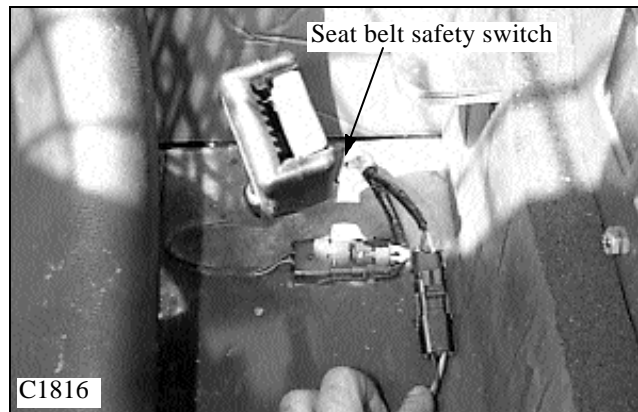
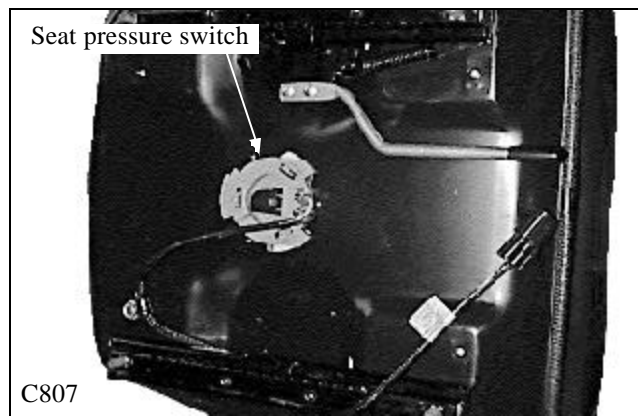
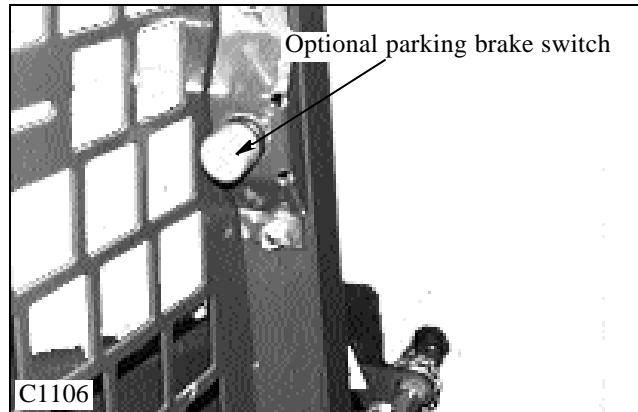



# TROUBLE SHOOTING 4.7



Symptom	Cause	Corrective Action	Section
Loader creeps, won't center	Neutral adjustment	Adjust linkage	4.1
	Worn, loose linkage	Replace, tighten parts	4.1
	Binding, dragging parts	Repair, replace	4.1
Steering jerky	Worn, loose linkage	Replace	4.1
	Binding linkage	Repair, replace	4.1
	Linkage adjustment	Adjust	4.1
	Low charge pressure	Repair, replace	2
Loader doesn't track straight	Limiter stops	Adjust	4.1
	Binding linkage	Repair, replace	4.1
	Hydrostatic failure	Repair, replace	2
Boom controls inoperative	Damaged cables, linkage	Replace	4.2, 4.3
	Safety switch ( s )	Adjust, replace	5
	Bad electrical ground	Repair	5
	Blown fuse	Replace	5
	Valve lock malfunction	Replace parts	1, 5
	Low hydraulic oil	Replenish	1
	No oil pressure	Test and repair	1
Boom operation slow	Cable linkage	Replace, adjust	4.2, 4.3
	Aux. hydraulics engaged	Disengage	
	Engine RPM low	Adjust	7
	Control valve relief	Adjust, replace	1
	Cylinder seal, damage	Repair, replace	1
Boom controls stiff	Cable wear	Replace	4.2, 4.3
	Pivot wear	Replace parts	4.2, 4.3
	Control valve wear	Repair, replace	1
Auxiliary hyd. inoperative (solenoid control type)	Blown fuse	Replace	5
	Switch ( s ) failure	Replace	5
	Aux. valve malfunction	Repair, replace	1
	Electrical short	Repair	5
	Bad electrical ground	Repair	5
Brake won't hold	Service plunger on brake valve open	Inspect and service	2
	Brake disc wear or damage	Repair, replace	2
Brake won't release	Blown fuse	Replace	5
	Safety switch malfunction	Adjust, replace	5
	Lack of hydrostatic charge pressure	Test, repair	2
	Brake valve failure	Repair, replace	2

# NOTES



# THOMAS