

SAFETY FIRST & GENERAL**TABLE OF CONTENTS**

1. FOR SAFETY	1-2	8. MAINTENANCE	1-22
1.1 Alert symbols.....	1-2	8.1 Maintenance schedule chart.....	1-22
2. SAFETY TIPS	1-3	8.2 Lubrication list.....	1-23
2.1 Safety gear.....	1-3	8.3 Daily check	1-24
2.2 Work place	1-3	8.3.1 Fuel system check	1-24
2.2.1 Ventilating system	1-3	8.3.2 Coolant check.....	1-25
2.2.2 Safe working place	1-3	8.3.3 Engine oil check.....	1-27
2.2.3 Illumination.....	1-3	8.3.4 Fluid oil check.....	1-28
2.2.4 Safety equipment.....	1-3	8.3.5 Chain box oil change	1-30
2.2.5 Clean working area.....	1-3	8.3.6 Fan belt tension adjustment.....	1-30
2.3 Safety instructions when preparing tractor...	1-4	8.3.7 Air cleaner check	1-31
2.4 Avoid fires	1-4	8.3.8 Tire check	1-32
2.5 Cautions when handling the battery	1-5	8.3.9 Fuse replacement.....	1-33
2.6 Cautions for high pressure hoses.....	1-5	8.3.10 Grease lubrication (Applying port)...	1-34
2.7 Use of appropriate tools and equipment....	1-6	9. GENERAL PRECAUTIONS	1-35
2.8 Handling of hazardous materials	1-6	9.1 Assembly and disassembly.....	1-35
2.9 Handling of rotating blade, shaft and driving belt	1-7	9.2 Tubes and rubbers.....	1-36
2.10 Prevention of scald.....	1-7	9.3 Lubricant.....	1-36
2.11 Disposal of environmental waste.....	1-8	9.4 Handling precautions for electrical parts and wiring	1-36
2.12 Cautions when handling tires	1-8	10. TIGHTENING TORQUE	1-39
3. SAFETY DECALS	1-9	10.1 General use screws, bolts and nuts.....	1-39
3.1 Location of decals	1-9	10.2 Stud bolts	1-39
4. DESCRIPTION FOR SYMBOLS AND ABBREVIATIONS	1-15	10.3 American standard screws, bolts and nuts with unc or unf threads.....	1-40
5. IDENTIFICATION NUMBER	1-16	10.4 High pressure hose union nut.....	1-40
5.1 Skid loader serial number	1-16	10.5 O-ring face type screw	1-40
5.2 Engine serial number.....	1-16	10.6 Fitting fixing screw	1-40
6. EXTERIOR VIEW & INTERIOR CABIN	1-17	11. PART NUMBER ASSIGNMENT STANDARD FOR HYUNDAI BOLTS AND NUTS	1-41
6.1 Exterior view	1-17	11.1 Part number assignment standard for KIOTI bolts	1-41
6.2 Interior cabin.....	1-18	11.2 Part number assignment standard for KIOTI nuts.....	1-42
6.3 Dimensions	1-19	12. UNIT CONVERSION TABLE	1-43
7. SPECIFICATIONS	1-20		

1. FOR SAFETY

- Most accidents can be avoided if basic safety instructions and regulations are followed. Always follow the safety regulations and avoid any dangerous situation to prevent an accident.
- You can be unexpectedly injured if inspecting or servicing the tractor without full knowledge of it. Read the service manual carefully before starting servicing and follow the instructions for servicing, maintenance and inspection to prevent any injury.

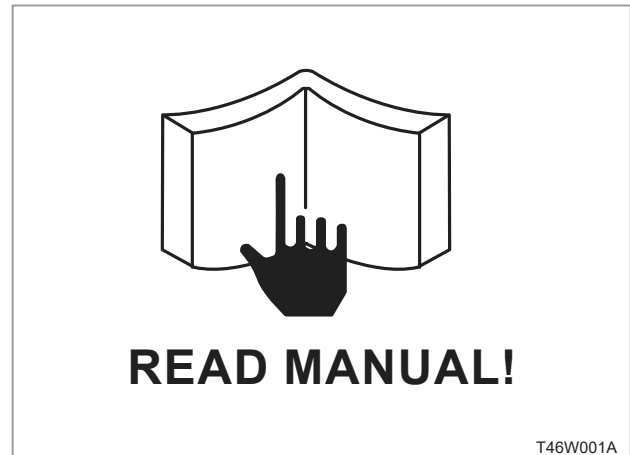

1.1 ALERT SYMBOLS

In this manual, the following safety-alert symbols are used. Their meanings are as follows:

► REMARK

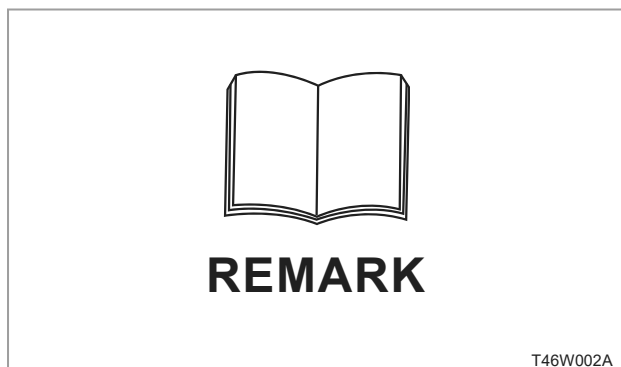

- Broaden your knowledge with additionally supplied service information for optimal service.

► IMPORTANT



- This mark indicates emphasis on information which can be confused when servicing. If this information is not carefully read and observed, the tractor cannot fully function or may be damaged.

► CAUTION



- This mark indicates potentially hazardous situation which, if not observed, may result in serious injury.

► WARNING



- This mark indicates hazardous situation which, if not observed, may result in death or injury.

2. SAFETY TIPS

2.1 SAFETY GEAR

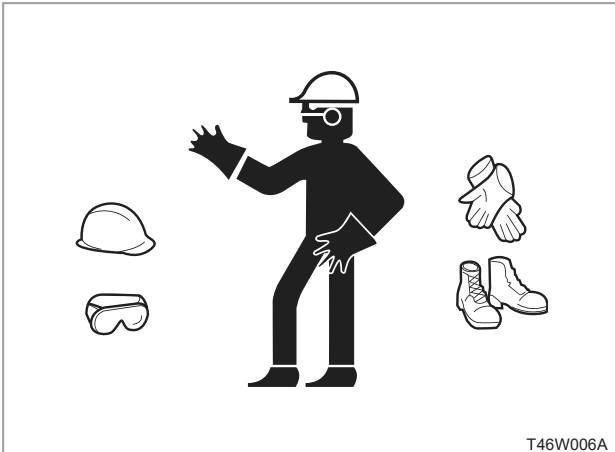

T46W006A

When working on the tractor, wear safety gloves, safety shoes, ear plugs, safety goggles, safety helmet, working clothes, etc. appropriate for your working environment. Never wear loose fitting clothing or a tie which can be caught to the rotating part. According to the statistics, most accidents that occurred with rotating parts are due to this inappropriate manner of wearing clothes.

2.2 WORK PLACE

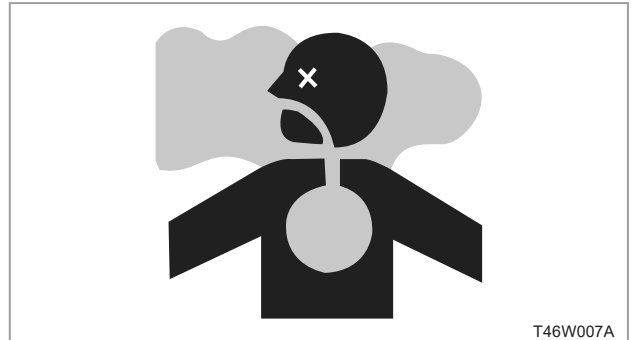

T46W007A

2.2.1 VENTILATING SYSTEM

The service should be performed in well-ventilated area. If the engine should be started in an enclosed place, the exhaust gas pipe should be installed.

! WARNING

- California Proposition 65 Warning
Inhaling exhaust gas can cause cancer or damage the generative function leading to infertility.

2.2.2 SAFE WORKING PLACE



T46W008A

The work should be done in a wide, level and safe place to prevent slip and fall accident.

2.2.3 ILLUMINATION

The work place should be well illuminated. If working in a dark place or under the tractor, use the work lamp. The work lamp should be covered by the safety cover. The bulb can cause fire due to leaked fuel if it is broken.

2.2.4 SAFETY EQUIPMENT

Be sure to keep a first aid kit and fire extinguisher handy at all times.

2.2.5 CLEAN WORKING AREA

Keep the working area clean before and during work. If any oil or fuel is spilled, it should be cleaned up immediately.

2.3 SAFETY INSTRUCTIONS WHEN PREPARING TRACTOR



- Lower the loader bucket on to the ground.

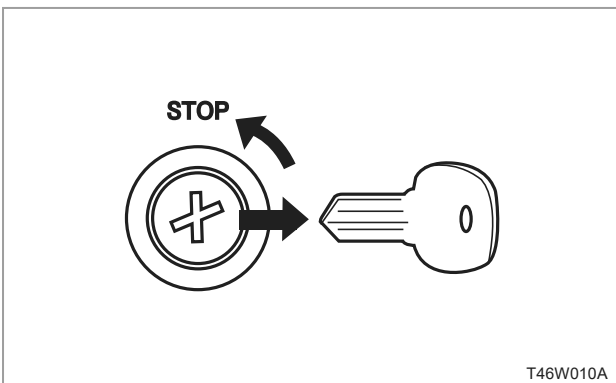

- Stop the engine and remove the key.
- Put "Do not operate" label on the tractor if necessary.

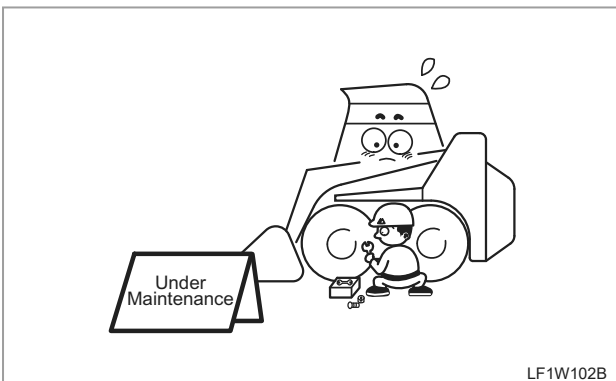

- Put a "No Operation" or "In Service" label on the vehicle body if necessary.

2.4 AVOID FIRES



- Never smoke or allow flames in your work area when servicing the fuel system.



- Keep flames or sparks away from the spray paint or fuel containers and be careful of leak.

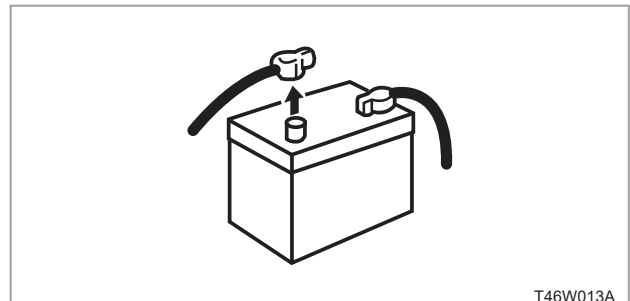

- Always disconnect the battery cable before servicing.
- Be extra cautious of fire when welding.



- Always keep a fire extinguisher in workshop.

2.5 CAUTIONS WHEN HANDLING THE BATTERY

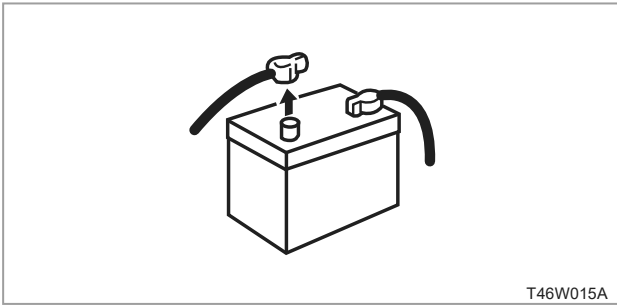

- Always disconnect the negative battery cable first and reconnect it last to avoid sparks from an accidental short circuit. You can get injured or fire may break out.

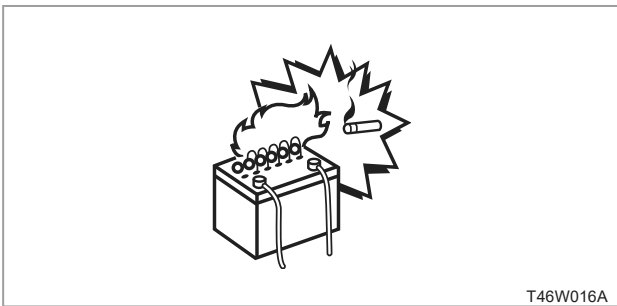

- Do not charge the frozen battery. Charging the frozen battery can cause explosion. Let the battery warmed up to ambient temperature (16°C, 60°F) before charging.

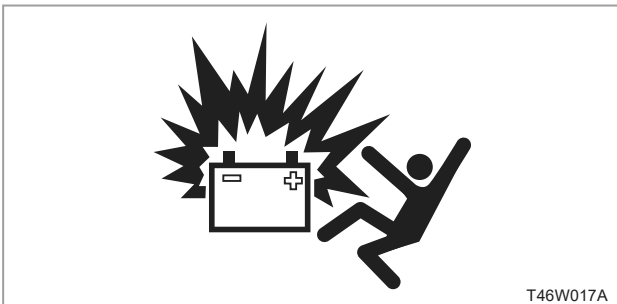

- Keep sparks and flames (match, lighter) away from the battery. The battery can explode due to the battery fluid.
- Never connect the battery's negative and positive cables with metal for test. Use only tester when checking the battery voltage.

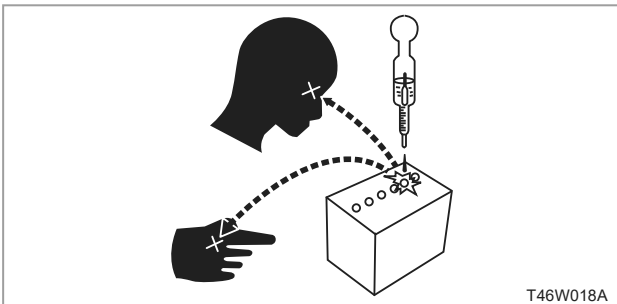

- The battery contains the acid that can burn you. When it contacts with your eyes, you may lose your sight.

2.6 CAUTIONS FOR HIGH PRESSURE HOSES

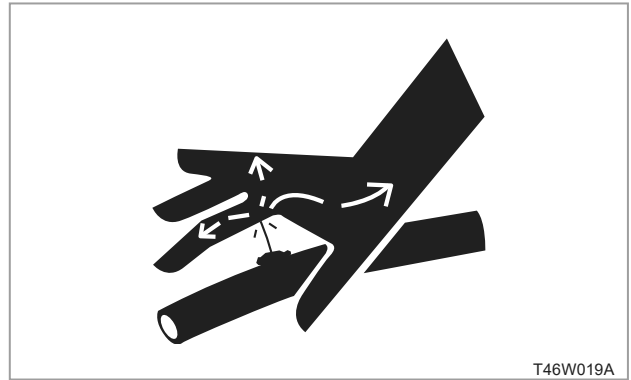

- The hydraulic fluid leaked from high pressure hoses or pipes can penetrate your skin.



- Before connecting a high pressure hose or pipe, stop the engine and depressurize it by valve.
- Check the bolts for tightness before starting the engine after servicing the hydraulic system.
- Use a cardboard or plank when checking leakage.



- Never weld the high pressure pipe or the surrounding area. The pipe or hose can be heated and explode which can lead to fire or burn.

2.7 USE OF APPROPRIATE TOOLS AND EQUIPMENT

- Use the appropriate tools in proper size. If an inappropriate tool is used, it can be slipped which can damage parts or injure you.
- Do not confuse units (mm, inch, etc.).
- Use the air impact wrench only when unscrewing the bolts or nuts. Such wrench should not be used when assembly precisely machined parts which its tightening torque should be strictly observed. It can cause malfunction.
- Be careful of a socket popped out due to the turning force when using the air impact wrench. Especially, be extra cautious when working on connection or socket with joint.

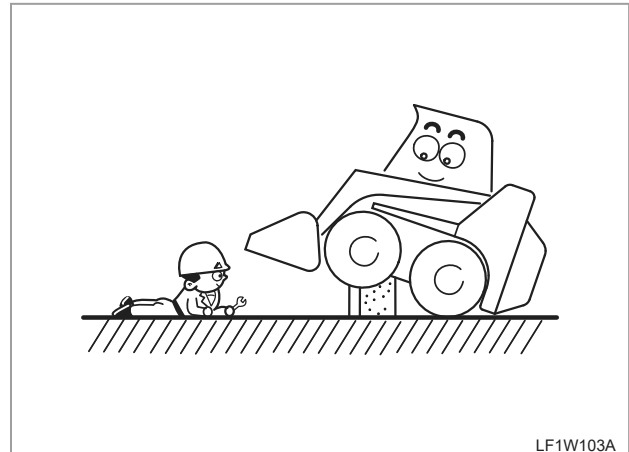

- When servicing the vehicle with its body raised using the boom and bucket, ensure to place safety jacks under the body. The body may fall, resulting in a crash accident.



- When lifting the tractor with a hydraulic jack or a hoist, fix it firmly and install the auxiliary support. Never work under the tractor if the support and the hydraulic jack (hoist) are not installed.
- When using a hydraulic jack or a hoist, do not use it over the limit of the equipment and the conveying belt.
- Make sure that the hydraulic lock operates properly before using the hydraulic jack. Improper use of lock can cause a serious accident.
- Check the buttons and operating direction of the hoist before using it. Improper operation can cause a serious accident.
- Do not use wooden blocks or bricks as support under the tractor. As the tractor's weight is continuously applied to them, they can be broken or collapsed.

2.8 HANDLING OF HAZARDOUS MATERIALS

- Dust containing hazardous substances can be harmful to the human body if inhaled. Therefore, do not blow it off with compressed air. Instead, wash it off or spray oil on it and then wipe it off.

2.9 HANDLING OF ROTATING BLADE, SHAFT AND DRIVING BELT

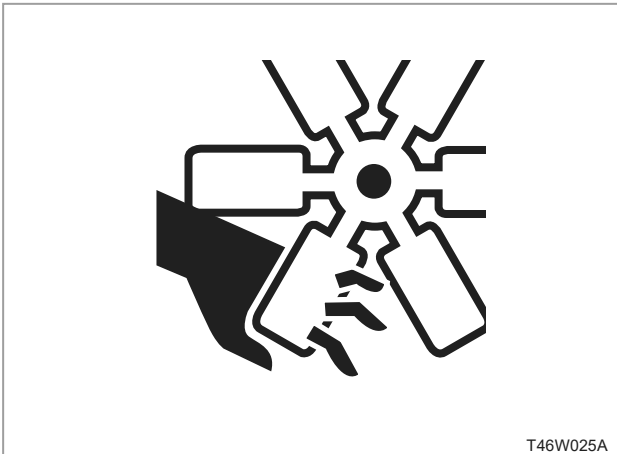

- Be careful not to get caught by the rotating engine cooling fan.

2.10 PREVENTION OF SCALD

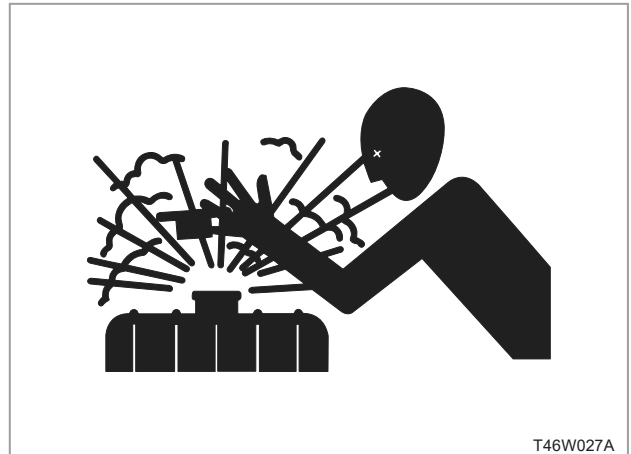

- Do not open the radiator cap when the radiator is hot. Hot coolant or steam can be surged leading to a serious scald.

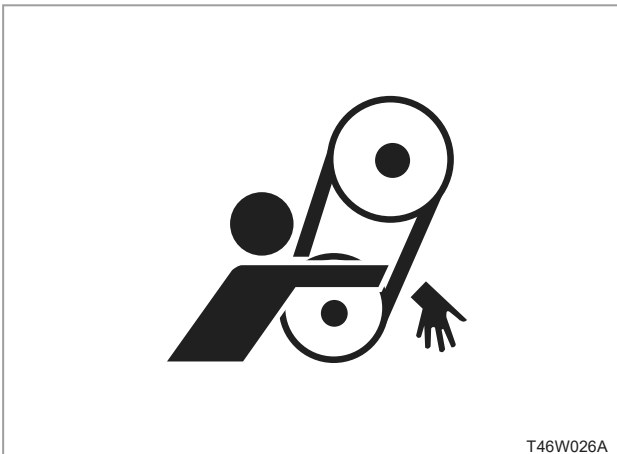

- You can be seriously injured if your hand or clothes is caught by the rotating fan belt or A/C belt.

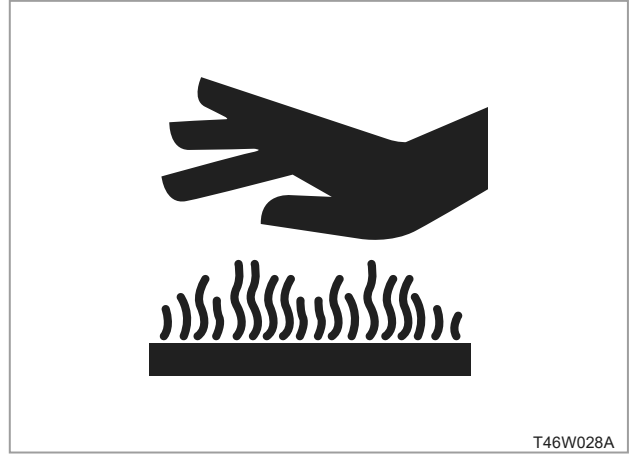

- Check the surface temperature of the container before draining the engine oil, transmission fluid, coolant, etc. If it is hot, let it cool down before draining it. There is danger of burning.
- Perform any service on the engine parts (muffler, exhaust manifold, turbocharger, etc.) only when they are not hot.

2.11 DISPOSAL OF ENVIRONMENTAL WASTE

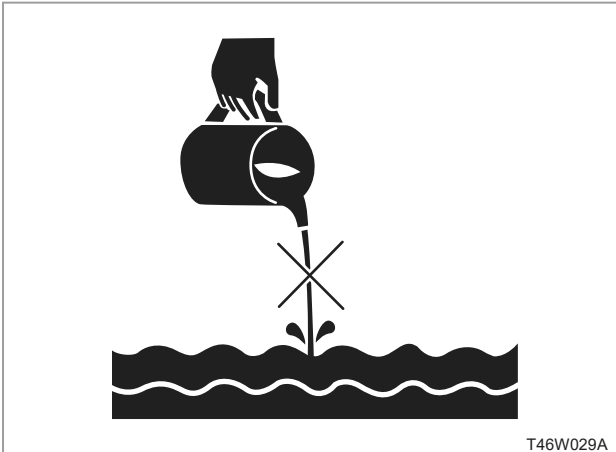

- Observe all relevant environmental protection regulations when disposing used oil, transmission fluid, coolant, oil filter, etc. Otherwise, they can pollute the environment seriously and you can be charged in violation of regulations.

2.12 CAUTIONS WHEN HANDLING TIRES



- The tire rims can fall out of the tires. Therefore, stay out of its way when checking or inflating tires.

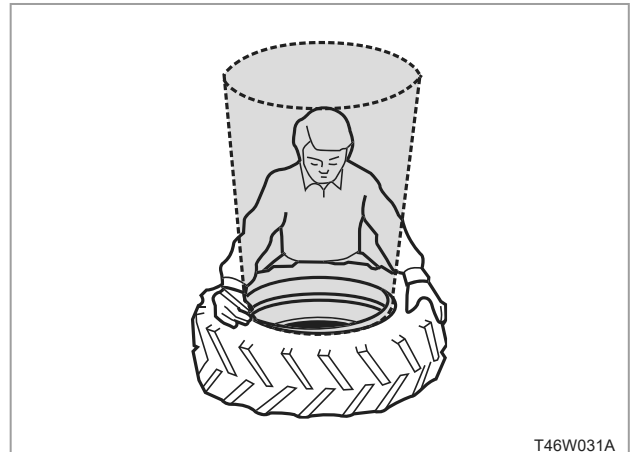

- Do not weld or apply heat to the tire rim or disc. The tire can explode due to the rapidly increased pressure in the tire.
- Check tires for inflation pressure, damage, deformation, extended wear on lug and damage of rim and disc. Also check if wheel bolts, rim bolts and nuts are loose.

3. SAFETY DECALS

- When replacing parts, be sure to install the appropriate safety decal as well. Otherwise, the customer's safety will be threatened.
- If a decal is damaged or detached, always replace with the appropriate decal.
- The decal and its attaching location are as follows.
- Part numbers appear at the bottom of decals.

3.1 LOCATION OF DECALS

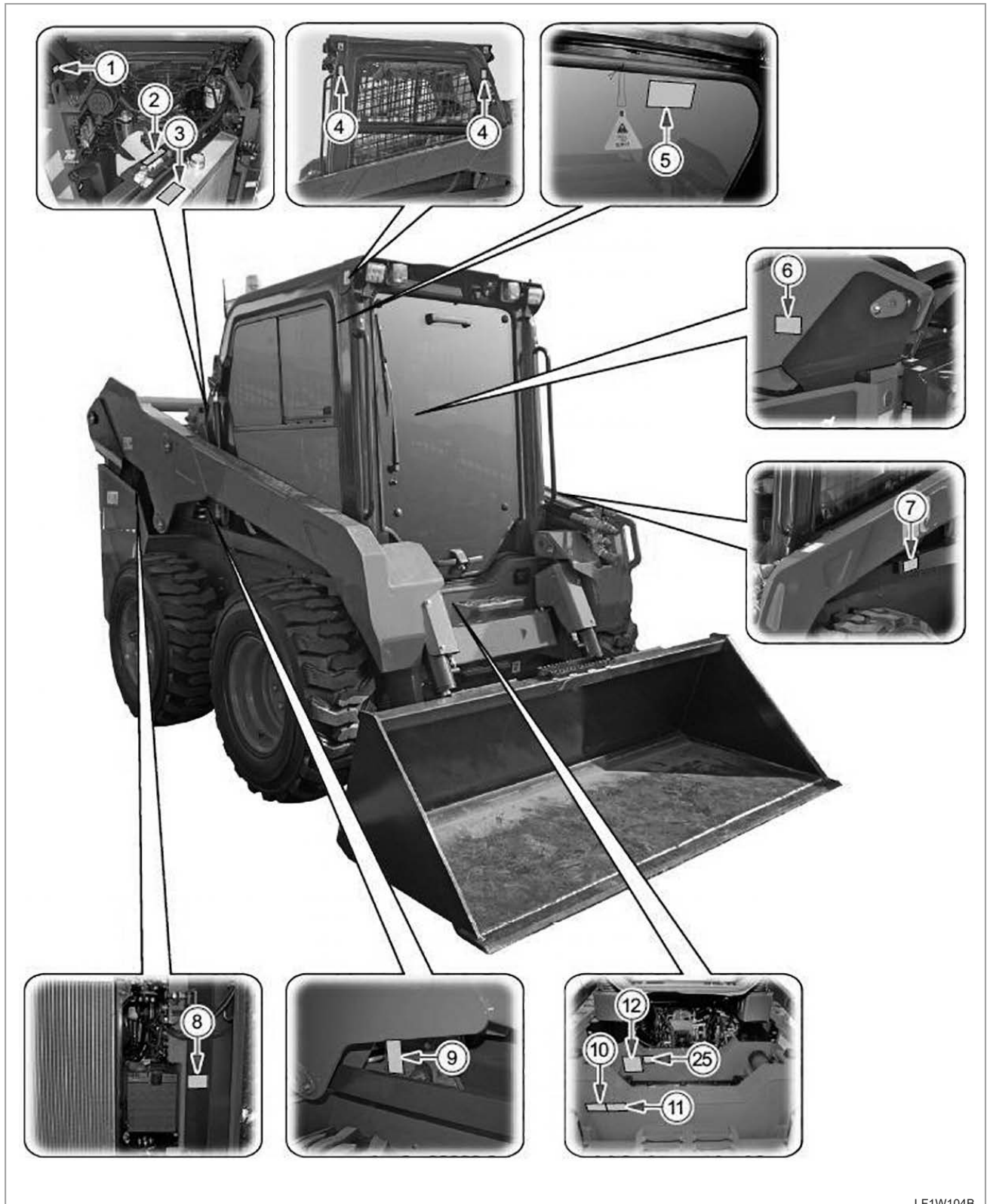

LF1W104B

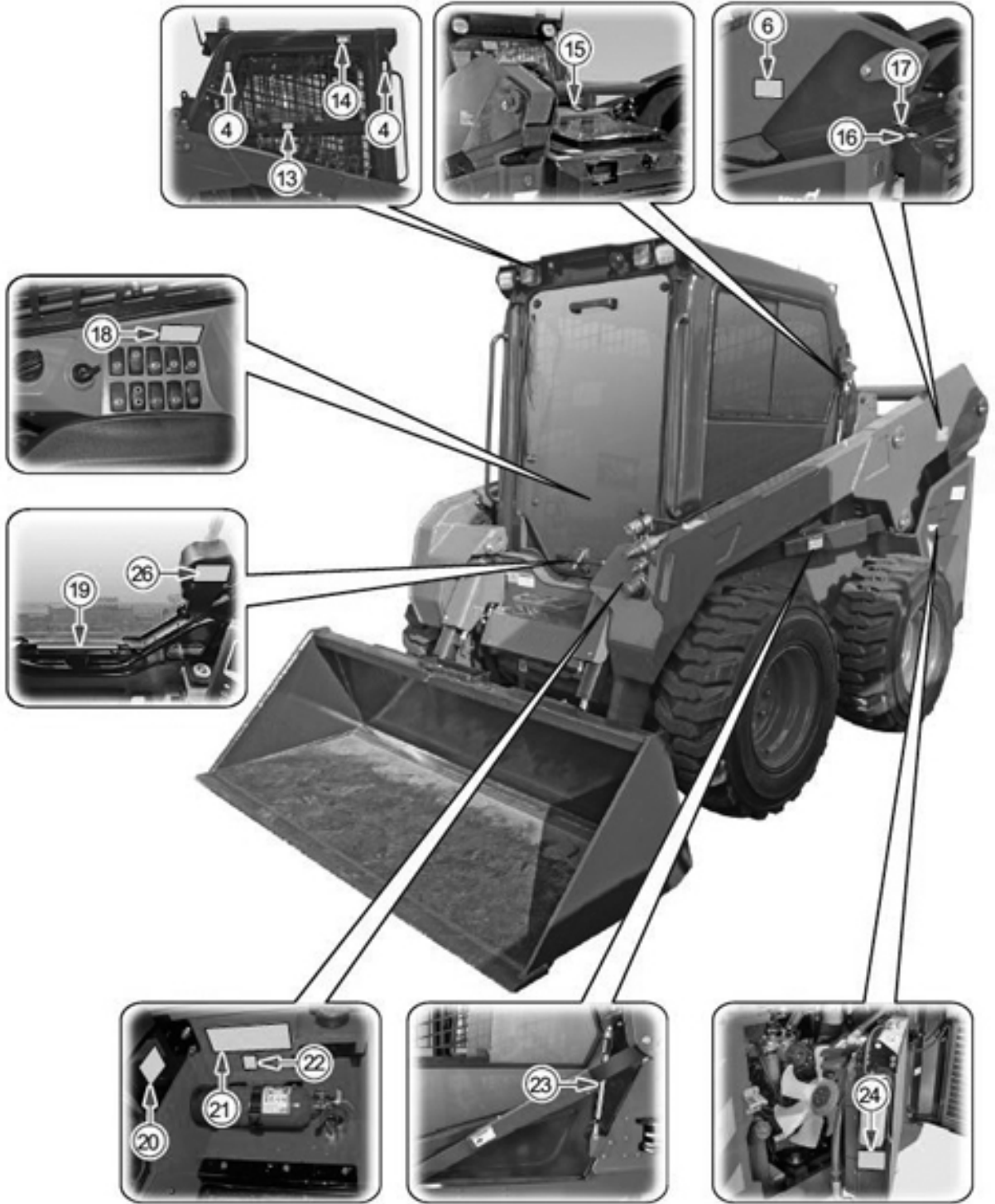

LF1W105B

(1) LF18-0017

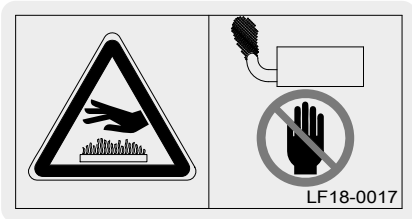

(6) LF18-0011

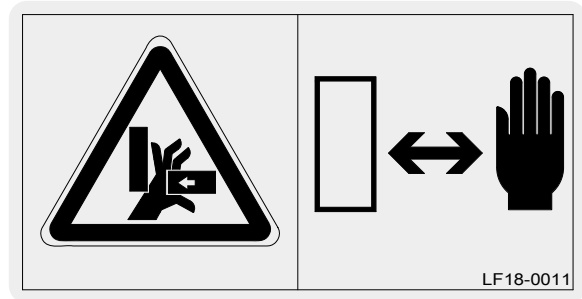

(2) LF18-0016

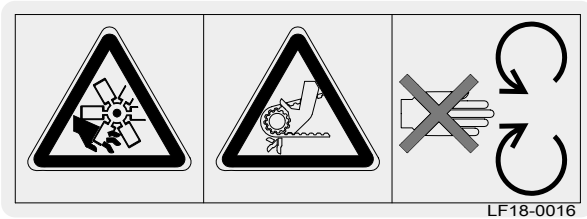

(7) LF18-0046

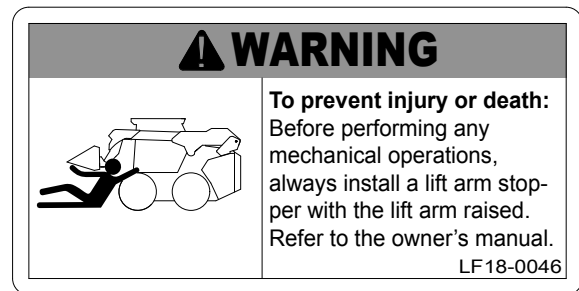

(3) LF18-0015

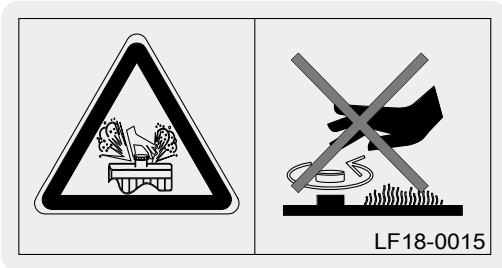

(8) LF18-0051

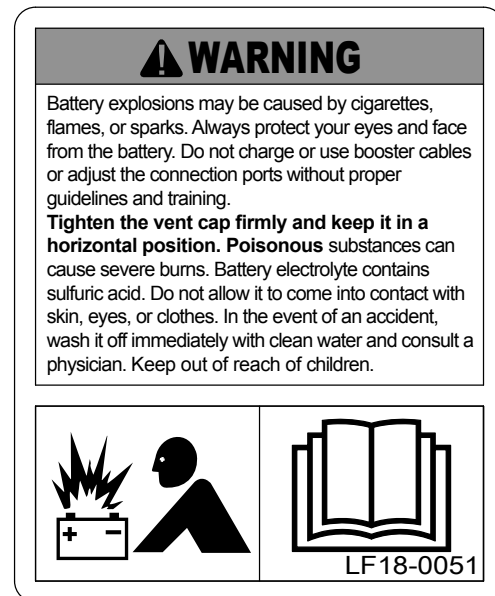

(4) LF18-0033

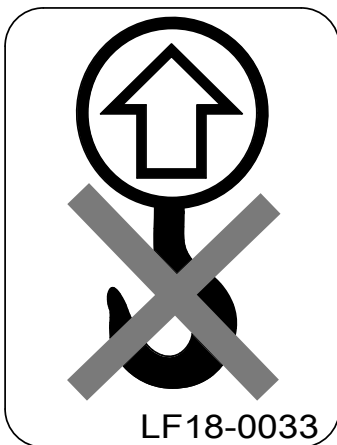

(5) LF18-0029

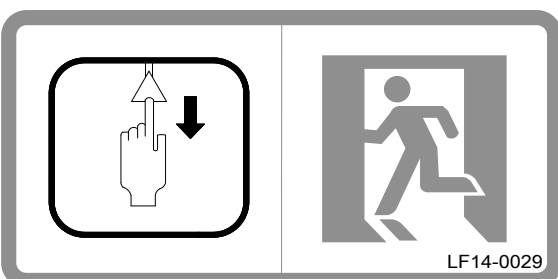

SAFETY FIRST

ENGINE

DRIVING & CHASSIS

HYDRAULIC SYSTEM

ELECTRIC SYSTEM

CABIN

INDEX

(9) LF18-0023

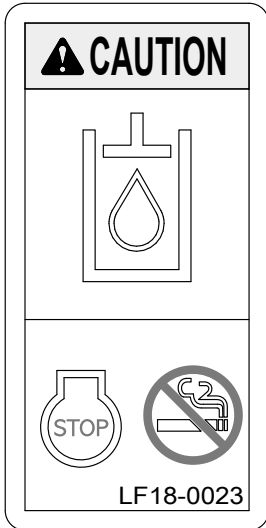

(10) LF18-0020

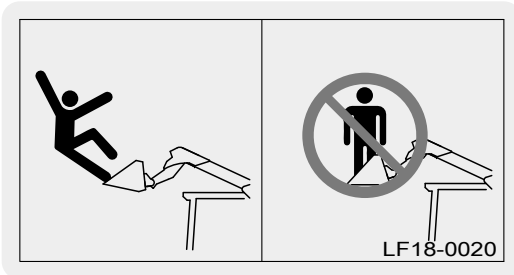

(11) LF18-0045

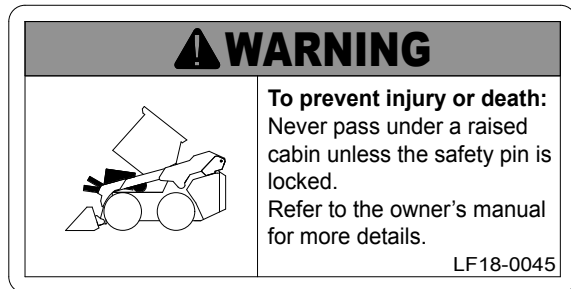

(12) LF18-0024



(13) LF18-0052

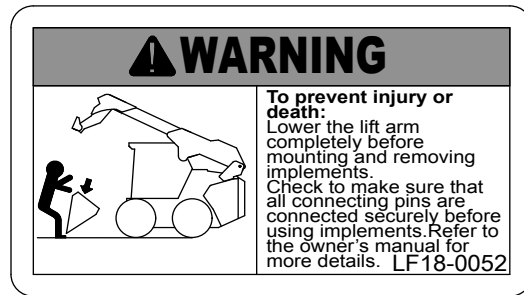

(14) LF18-0028

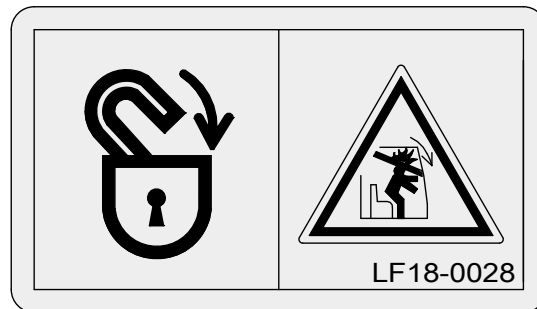

(15) LF18-0045

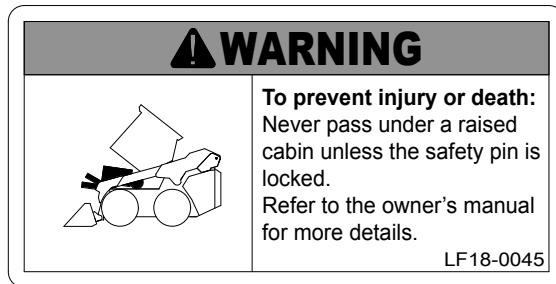

(16) LF18-0044

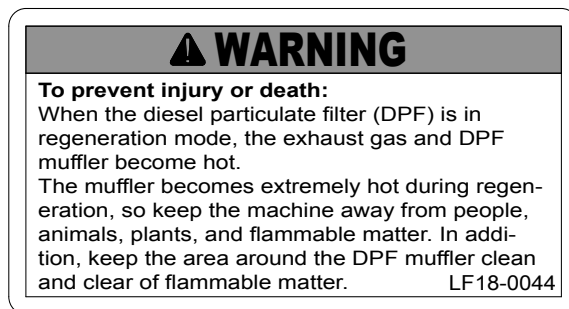

(17) LF18-0049

⚠ WARNING
<p>To prevent injury or death: Take care to prevent hands or body parts from being caught in the door when closing the top door on the engine room.</p> <p style="text-align: right;">LF18-0049</p>

(21) LF18-0071

⚠ WARNING	⚠ WARNING
<p>The operation of this equipment may produce flames which can cause a fire around dry matter. A flame removal device is needed. The operator must comply with all relevant legislation and fire prevention requirements.</p>	<p>To prevent injury:</p> <ul style="list-style-type: none"> • Make sure to read and understand the owner's manual before operating the machine. • Familiarize yourself with all controls. • Check to make sure that the surrounding area is clear of people before operating the machine. • Keep all safety devices in place. • Do not allow people to ride on implements or on the outside of the vehicle. • Before leaving the machine, lower all implements to the ground, turn off the engine, and remove the key. <p style="text-align: right;">LF18-0071</p>

(18) LF18-0053

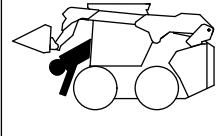
⚠ WARNING
 <p>To prevent injury or death: Do not stick any part of your body outside the cabin while the machine is running. Refer to the owner's manual. LF18-0053</p>

(22) LF14-0908



(19) LF18-0054

⚠ WARNING	<p>To prevent injury or death: Open and close the door with both hands while taking care not to hit your head. After the door is open, move the locking pins on both sides outwards to secure the door in order to prevent it from falling suddenly.</p> <p style="text-align: right;">LF18-0054</p>
------------------	---

(20) LF14-0965

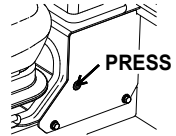
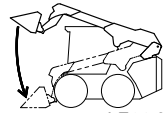
⚠ WARNING
<p>To prevent severe injury or death: Do not leave the work site with the lift arm raised. In the event of an emergency where the engine shuts off or the lift arm must be lowered, check in a seated position whether the area under the lift arm is clear. Then, press the bottom left button to lower the lift arm.</p>
  <p style="text-align: right;">LF14-0965</p>

(23) LF18-0050

⚠ WARNING	<p>To prevent injury or death: Check to make sure that the stopper pin used to secure the cabin is in the locked position. Refer to the owner's manual.</p> <p style="text-align: right;">LF18-0050</p>
------------------	--

(24) LF18-0069

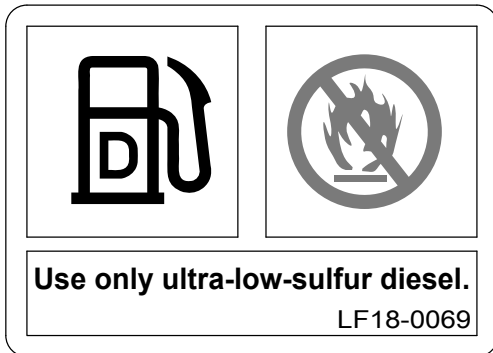

(25) LF14-0983

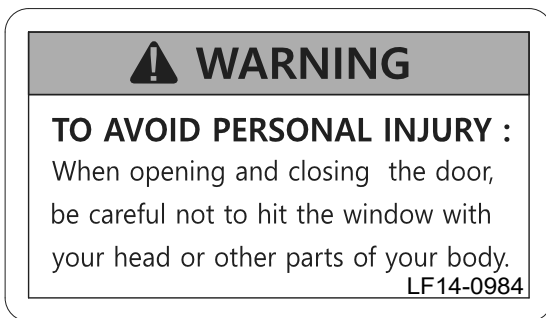



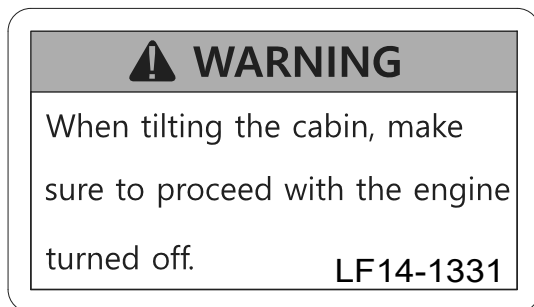

















(26) LF14-1330



4. DESCRIPTION FOR SYMBOLS AND ABBREVIATIONS

There are various symbols used in this manual. Their design and meanings are as follows:

SYMBOLS

	Fuel level warning lamp		Hydraulic lock device indicator		Water-In-Fuel warning lamp
	Auxiliary operation indicator		Quick attachment unlock warning lamp		Parking brake indicator
	Auxiliary hydraulic indicator		Self-leveling indicator		Safety cover warning lamp
	Auxiliary electric port indicator		Left turn signal lamp		Safety bar warning lamp
	High flow indicator		Right turn signal lamp		Battery charge warning lamp
	2-Speed indicator		Engine oil pressure warning lamp		Menu switch
	Hazard warning lamp, Fluid high temp. warning lamp		Engine pre-heating indicator		Menu left move button
	Consumables management warning lamp		Check engine warning lamp		Menu right move button/Camera button
	Engine coolant warning lamp		DPF Regeneration warning lamp		Enter button
	Auxiliary hydraulic port M/F indicator		DPF regeneration progress indicator		ESC/Buzzer stop button
	14-pin C indicator		Emission warning lamp		Tachometer
	Ride control indicator		Engine stop warning lamp		Hour meter

DESCRIPTION FOR ABBREVIATIONS

- 4WDFour wheel drive
- APIAmerican Petroleum Institute
- ASAE American Society of Agricultural Engineers
- ASTMAmerican Society for Testing and Materials
- Hi-LoHigh speed-Low speed
- m/sMeter per second
- P.T.O.....Power Take Off
- RH/LHRight hand side and left hand side (seen from operator)
- ROPSRoll over protection structure
- rpmRevolutions Per Minute
- SAESociety of Automotive Engineers
- SMVSlow Moving Vehicle

5. IDENTIFICATION NUMBER

5.1 SKID LOADER SERIAL NUMBER

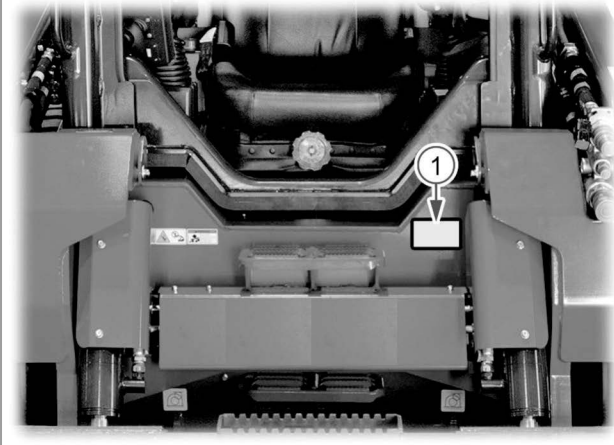

The skid loader's serial number (1) is attached on the front of the vehicle with a label.

5.2 ENGINE SERIAL NUMBER

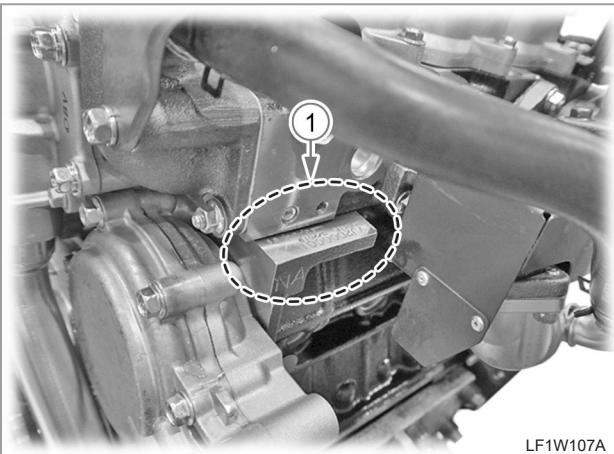

The engine serial number (1) is stamped on the cylinder block surface on the rear side of the gear case.

6. EXTERIOR VIEW & INTERIOR CABIN

6.1 EXTERIOR VIEW

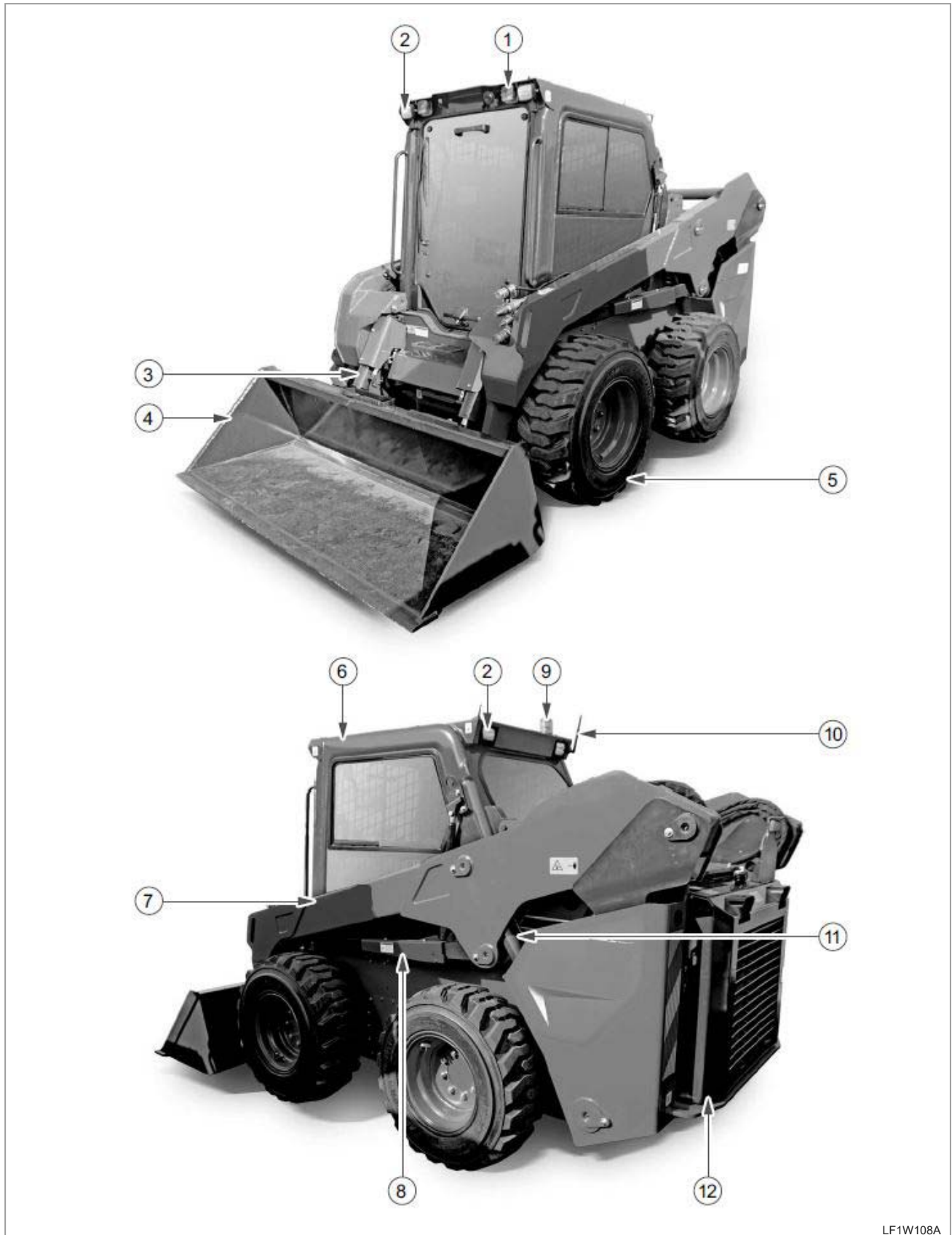

LF1W108A

- (1) Turn signal lamp
- (2) Work lamp
- (3) Tilt cylinder
- (4) Bucket

- (5) Tire
- (6) Cabin (ROPS cabin)
- (7) Boom
- (8) Boom lock

- (9) Beacon lamp
- (10) Antenna
- (11) Lift cylinder
- (12) Rear door

6.2 INTERIOR CABIN



LF1W143A

- | | |
|--|--|
| (1) Engine acceleration dial | (8) Stereo |
| (2) RCV(RH)[Right control lever (Boom & Bucket)] | (9) Driver's seat |
| (3) Seat bar | (10) RCV(LH)[Left control lever (Driving)] |
| (4) Fuse box | (11) Air conditioner controller |
| (5) Instrument panel | (12) Right control panel |
| (6) Key switch | (13) Left control panel |
| (7) Power outlet | |

6.3 DIMENSIONS

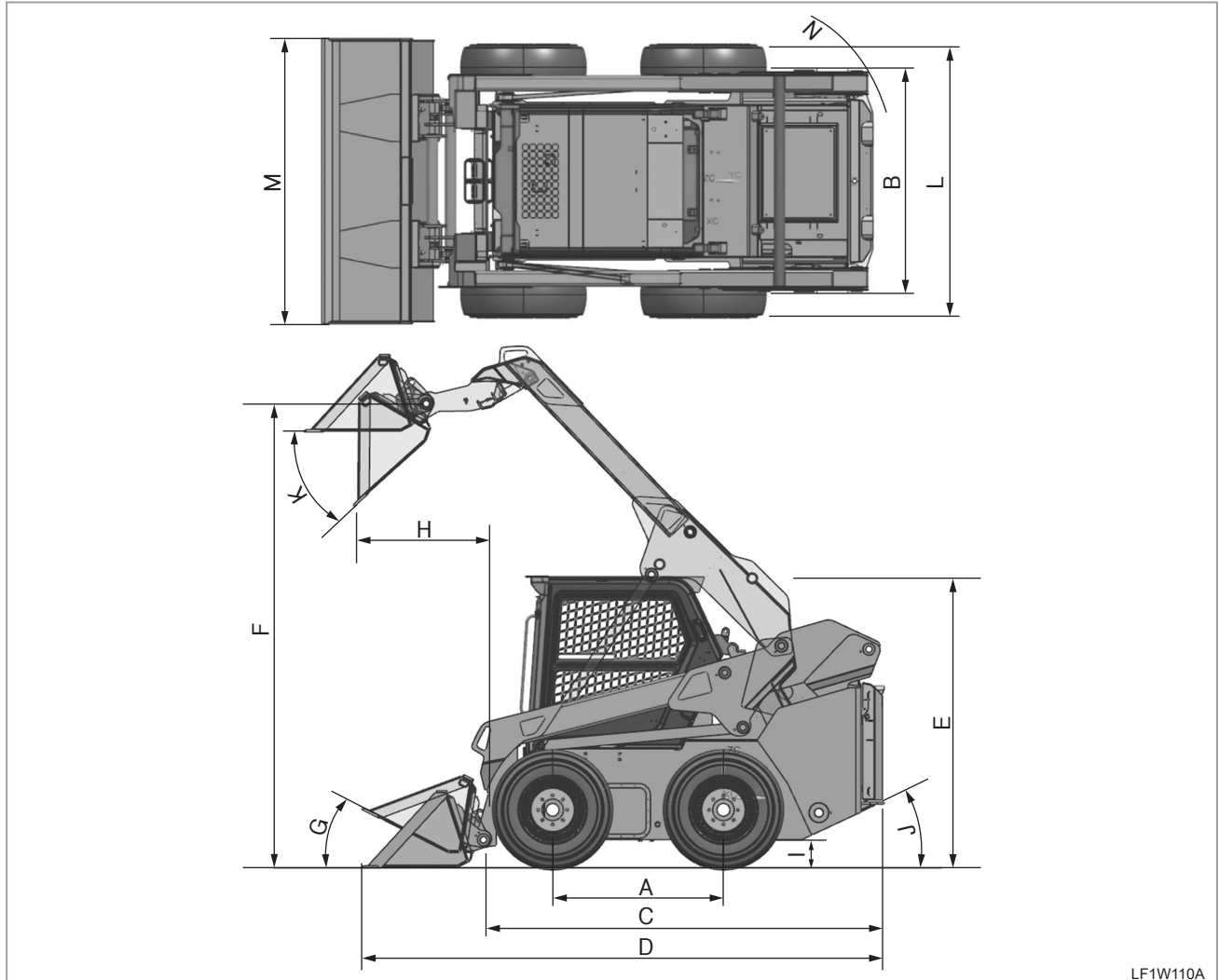

LF1W110A

mm (in.)

ITEM		DIMENSIONS
A	Wheel base	1,200 (47.2)
B	Tread	1,513 (59.6)
C	Overall length (Excluding the bucket)	2,960 (116.5)
D	Overall length (Including the bucket)	3,675 (144.7)
E	Overall height (Cabin upper)	2,161 (85.1)
F	Bucket hinge pin height at max. lift	3,215 (126.6)
G	Rollback angle at carry position	29°
H	Reach at max. lift and dump	949 (37.4)
I	Ground clearance	195 (7.7)
J	Departure angle	25°
K	Maximum dumping angle	44.3°
L	Overall width	1,820 (71.7)
M	Bucket width	1,890 (74.4)
N	Turning radius from rear	1.850 (72.8)

7. SPECIFICATIONS

ITEM		MODEL		
		HS120V		
Engine	Model	4HT14		
	Max. power	HP(kw) / rpm	73.6 (54.9) / 2,400	
	Type	Watercooled 4-cycle direct injection, 4-cylinder turbo intercooler, diesel		
	Number of cylinders	4		
	Bore x Stroke	mm(in.)	87 x 102.4 (3.4 x 4.0)	
	Total displacement	cc(cu in.)	2,435 (148)	
	Rated revolution	rpm	2,400	
	Injection sequence	1 - 3 - 4 - 2		
	Compression ratio	17.4 : 1		
Capacity	Fuel tank capacity	ℓ(u.s.gal.)	100 (26.4)	
	Capacity (Including the filter)	ℓ(u.s.gal.)	9 (2.4)	
	Engine coolant (Engine only)/ (Including the radiator)	ℓ(u.s.gal.)	4.2 (1.1) / 10.4 (2.7)	
	Hydraulic tank	ℓ(u.s.gal.)	38 (10.0)	
	Chain box (LH/RH)	ℓ(u.s.gal.)	13 (3.4)	
Dimension	Overall length (Including the bucket)	mm(in.)	3,675 (144.7)	
	Wheel base	mm(in.)	1,200 (47.2)	
	Cabin upper height	mm(in.)	2,161 (85.1)	
	Ground clearance	mm(in.)	195 (7.7)	
	Overall width (Tire)	mm(in.)	1,820 (71.7)	
	Bucket width	mm(in.)	1,890 (74.4)	
	Tread	mm(in.)	1,513 (59.6)	
Hydraulic	Basic type	Loader pressure	bar(psi)	230 (3,336)
		Loader flow rate	lpm(gpm)	82.9 (21.9)
		Hydraulic output	kW(HP)	31.1 (41.8)
	High pressure type	Loader pressure	bar(psi)	-
		Loader flow rate	lpm(gpm)	-
		Hydraulic output	kW(HP)	-
Drive	1 Speed	kph(MPH)	12.8 (7.95)	
	2 Speed (H, L)	kph(MPH)	N/A	
	Tire	12 x 16.5 - 12PR		

ITEM		MODEL		
		HS120V		
Operation	Operating weight (With operator)	kg(lb)	3,847 (8,481)	
	Rated operating capacity (Including the counter weight)	kg(lb)	1,330 (2,932)	
	Tipping load	kg(lb)	2,440(5,380)	
	Penetrating power, tilt (bucket)	kg(lb)	2,870(6,327)	
	Penetrating power, lift	kg(lb)	1,975(4,354)	
	Draft force	kgf(lbf)	2,475 (5,456)	
	Bucket capacity	Rated	m ³	0.35
		Heaped	m ³	0.44
Operation type			ISO pilot	

※ NOTES: The specifications are subject to change without notice.

SAFETY FIRST

ENGINE

DRIVING & CHASSIS

HYDRAULIC SYSTEM

ELECTRIC SYSTEM

CABIN

INDEX

8. MAINTENANCE

8.1 MAINTENANCE SCHEDULE CHART

No.	Interval		Run hour								If necessary	Remarks	
			10	50	100	200	250	500	800	1000			5000
1	Fluid	Check & Replenishment	○										
		Change									○		
2	Battery (Voltage)	Check			○								
3	Fluid filter	Replace & Adjust					⊙	○					
4	Safety bar malfunction	Check	○										
5	Air cleaner element	Check & Clean					○						
		Replace									○		
6	Radiator coolant	Check & Replenishment	○										
		Change								○			
7	Engine oil	Check			○								
		Change					○						
8	Engine oil filter	Change				○							
9	Pins-Grease	Check & Replenishment	○										
10	Fuel filter element	Replace				○							
11	Fan belt tension & damage	Check				○							
12	Water separator	Check				○							
13	Fuel hose	Check			○								
		Replace											Every 2 years
14	Tire wheel nut torque	Check	○										
15	Tire (Air pressure)	Check & Replenishment	○										
16	Chain case oil	Check	⊙										
		Change								○			
17	HST filter	Replace					⊙	○					
18	Engine valve gap	Adjust							○				
19	Chain tension	Replace & Adjust								○		○	

! INTERVAL

- The jobs indicated by ⊙ must be done after the first 10 hours or 250 hours of operation.
- The service interval is based on the hour meter on the instrument panel.
- This service interval assumes general maintenance condition and may not be suitable for other conditions, depending on the work site's conditions.
- Make sure to stop the engine before replenishing oil or fluid.

8.2 LUBRICATION LIST

To prevent serious equipment damage, use only genuine KIOTI fluids, oils and greases, or equivalents.

NO.	ITEM		CAPACITY	LUBRICANTS
1	Fuel		100 ℓ (26.4 u.s.gal.)	Ultra-low sulfur diesel (Sulfur content: 15 ppm or less)
2	Coolant	Engine only	4.2 ℓ (1.11 u.s.gal.)	Fresh clean water with anti-freeze (ethylene glycol) (50:50)
		Including the radiator	10.4 ℓ (2.75 u.s.gal.)	
3	Engine crankcase		9 ℓ (2.38 u.s.gal.)	Engine oil: API Classification CJ4, SAE15W-40
4	Fluid		38 ℓ (10.03 u.s.gal.)	Hydraulic oil ISO VG46
5	Chain box oil (LH/RH)		13 ℓ (3.43 u.s.gal.)	
6	Grease		Sufficient amount	Grease oil NLGI #2

8.3 DAILY CHECK

8.3.1 FUEL SYSTEM CHECK

FUEL TANK REMAINING CHECK

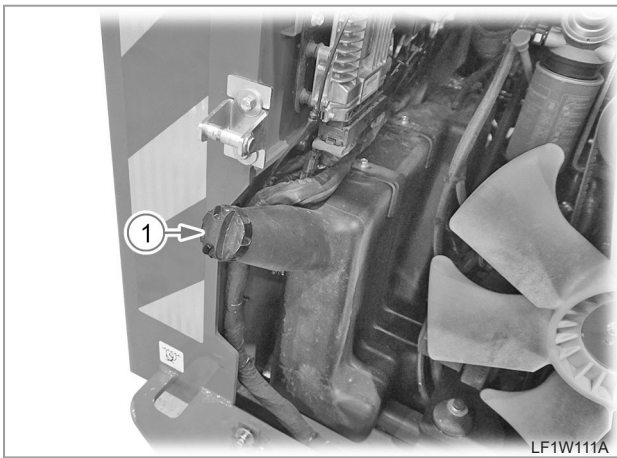

(1) Fuel tank cap

Fuel tank capacity	100 ℓ (26.4 U.S.gal.)
---------------------------	-----------------------

⚠ CAUTION

To avoid personal injury :

- Do not smoke while refueling.
- Be sure to stop the engine before refueling.
- As dirt or sand contained in fuel may cause malfunction to the HP fuel pump, use the strainer when refueling.

1. Turn the key switch to "ON", check the amount of fuel showing on the fuel gauge.
2. Fill fuel tank when the fuel gauge drops below the "E" point or less fuel in the fuel tank.

! IMPOARTANT

- Do not permit dirt or foreign materials to get into the fuel system.
- Be careful not to let the fuel tank become empty, otherwise air will enter the fuel system, requiring the fuel system to be bled before next engine start.
- Be careful not to spill during refueling. If a spill should occur, wipe it off at once. Fuel on the tractor may cause a fire.
- To prevent condensation (water) accumulation in the fuel tank, fill the tank before parking the tractor overnight.
- When operating the machine in winter season after a long period of time, fuel for winter season should be used.

FUEL FILTER WATER REMOVAL

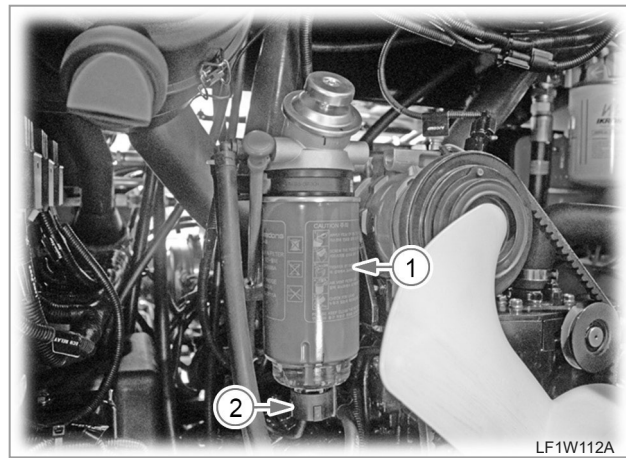

1. Water and foreign material included in fuel is filtered and collected at the bottom of the fuel filter.
2. Unscrew the plug on the bottom of the fuel filter, drain the water and foreign material from the inside, and then hand-tighten the plug.
3. Start the engine and check for fuel leakage.

FUEL SYSTEM AIR BLEEDING

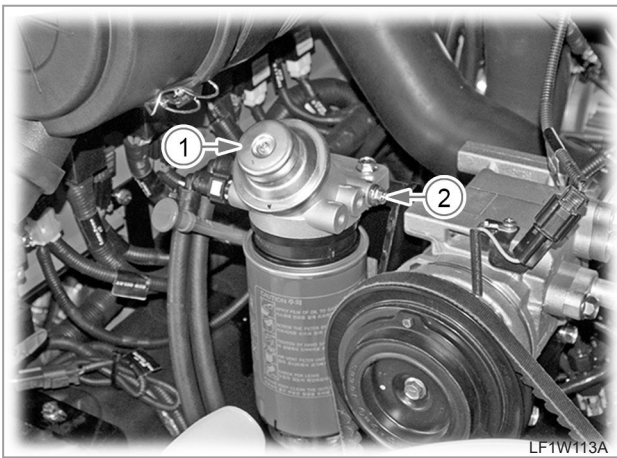

(1) Priming pump (2) Air bleeding bolt

1. Ensure that the amount of fuel in the fuel tank is sufficient.
2. Loosen the bleeding bolt on the fuel filter and pump the priming pump on top of the fuel filter several times.
3. Fuel with bubbles flows out of the bleeding bolt hole at first. When fuel without bubbles starts to flow out, the air is completely bled. Then, tighten the bleeding bolt.
4. Start the engine.

8.3.2 COOLANT CHECK

LEVEL CHECK

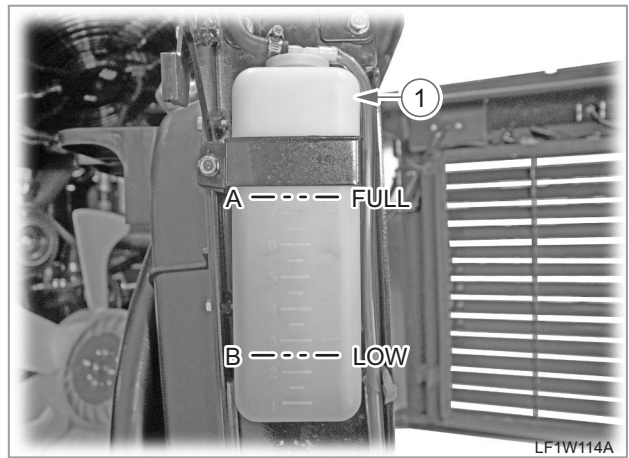

(1) Coolant aux. tank (A) FULL (B) LOW

⚠ CAUTION

To avoid personal injury:

- Do not remove the radiator cap while coolant is hot.
- When cool, slowly rotate cap to the first stop and allow ample time for excess pressure to escape before removing the cap completely.

1. Make sure to see that the coolant level is between the "FULL" and "LOW" marks of recovery tank.
2. When the coolant level drops due to evaporation, add water only up to the full level.

In case of leakage, add anti-freeze and water in the specified mixing ration up to the full level.

❗ IMPOARTANT

- If the radiator cap has to be removed, follow the caution above and securely re-tighten the cap.
- Use clean, fresh water and anti-freeze to fill the recovery tank.
- If water should leak, consult your local HYUNDAI Dealer.

COOLANT CHANGE

1. Park the vehicle on level ground, stop the engine and let the engine cool down.

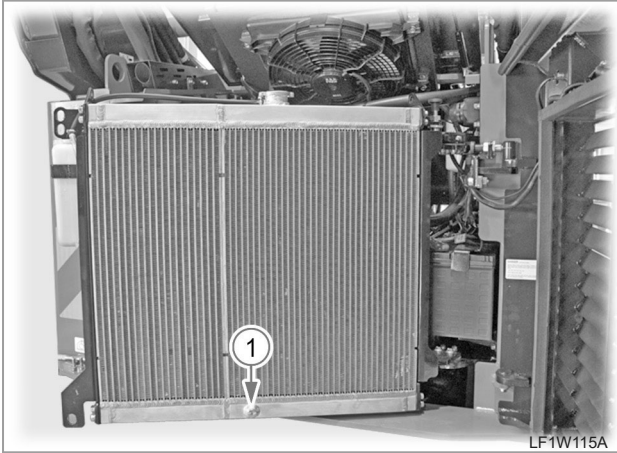

2. After confirming that the coolant temperature is sufficiently decreased, open the radiator cap and unscrew the drain plug (1) on the bottom of the radiator to drain the coolant completely.
3. After draining the coolant, tighten the drain plug and add the specified amount of mixture of 50 percent clean water and 50 percent antifreeze.

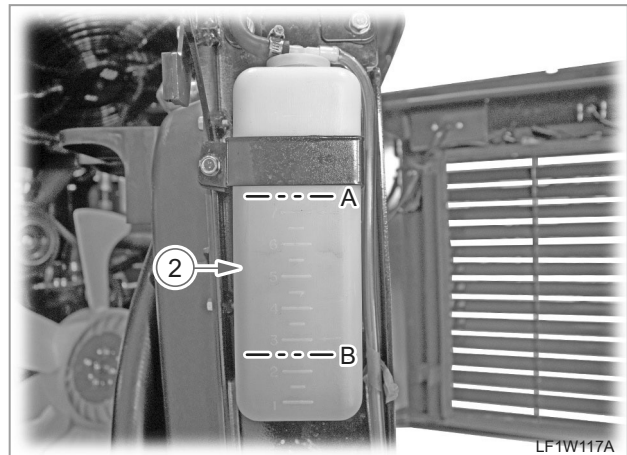
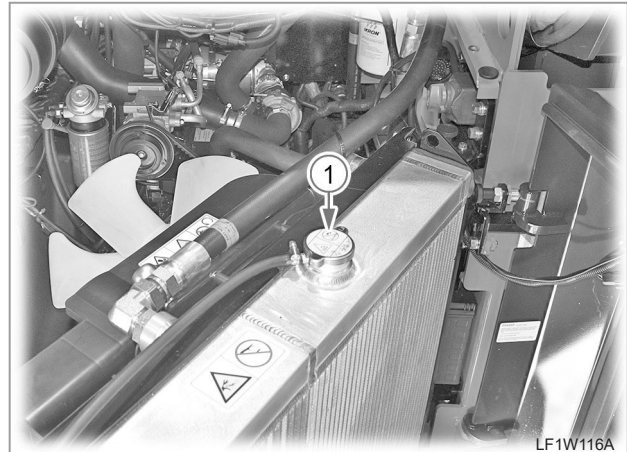

- (1) Radiator cap (A) Max
 (2) Aux. water tank (B) MIN

4. After adding coolant up to the specified level in the reservoir tank, tighten the radiator cap (1) firmly, start the engine and idle it for a few minutes.
5. Stop the engine, let it cool down, and then check the coolant level again. If necessary, add more coolant.

Coolant capacity	10.4 ℓ (2.75 u.s.gal.)
-------------------------	------------------------

8.3.3 ENGINE OIL CHECK

LEVEL CHECK

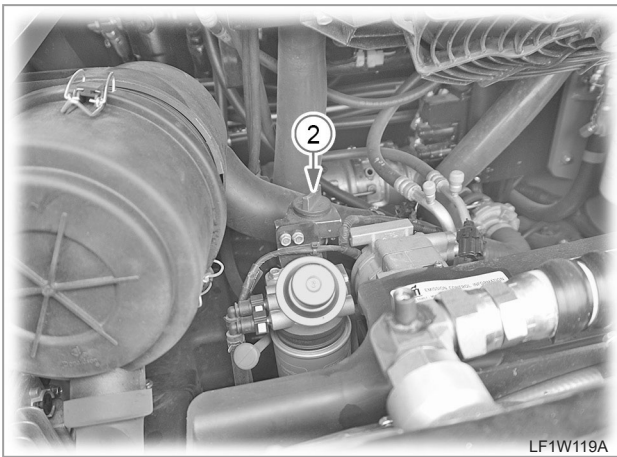
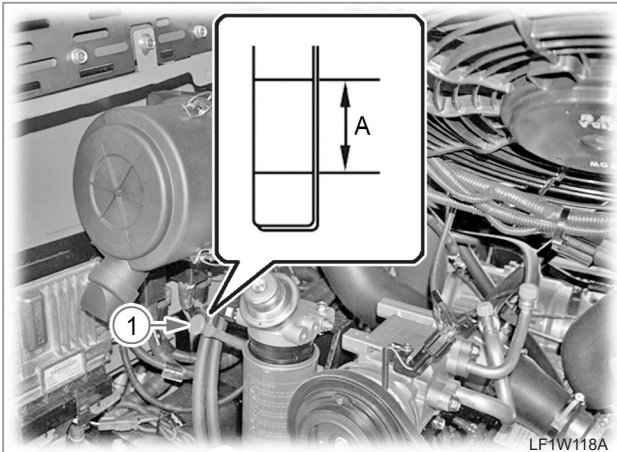

(1) Oil gauge (A) Oil level range
(2) Oil filler

! IMPOARTANT

- When using oil of different maker or viscosity from the previous one, remove all of the old oil. Never mix two different types of oil.
- Do not start the engine when the oil level is below the lower limit.

1. Park the vehicle on on firm and level ground.
2. Check the engine oil before starting the engine or 5 minutes or more after the engine has stopped.
3. To check the oil level, pull out the oil dipstick (1), clean it, and then insert it into its original position.
4. Then, pull it out again and check if the oil level is between the two notches (A)(within the specified range). If the oil level is too low, add some new oil so that the level is within the allowable range through the oil filler (2).

ENGINE OIL, OIL FILTER REPLACEMENT

1. Park the vehicle on level ground. Start the engine and let it warm up. Then, stop the engine and apply the parking brake.

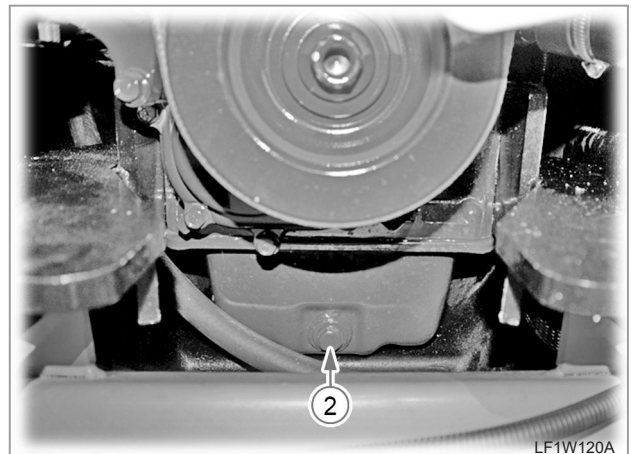
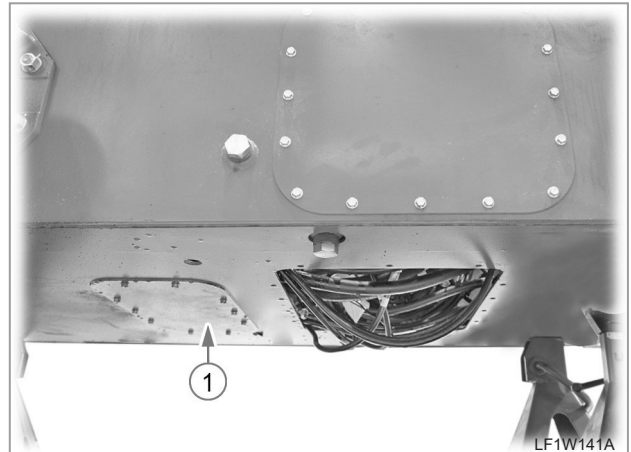

2. Remove the maintenance plate cover (1) on the bottom of the engine oil pan, place a container underneath to collect oil, and then unscrew the drain plug (2) on the front of the engine to drain the oil completely.



LF1W121A

3. Remove the engine oil filter (1), which is located under the fuel filter on the right side of the engine, by turning it counterclockwise.
4. After applying a thin coat of engine oil on the O-ring section of a new filter, hand-tighten it firmly.
5. Add the specified amount of the specified engine oil through the oil filler hole. Then, tighten the engine oil filter to the specified torque.

Engine oil capacity	9.0 ℓ (2.4 u.s.gal.)
----------------------------	----------------------

8.3.4 FLUID OIL CHECK

LEVEL CHECK (OIL TANK)

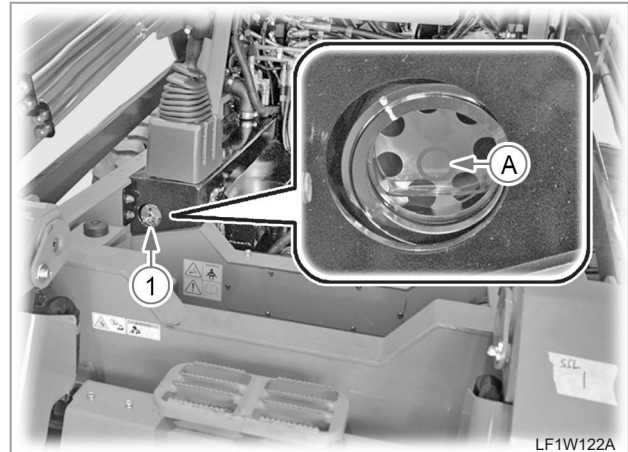

LF1W122A

- (1) Oil tank oil level check window
(A) Optimal level

1. Park the vehicle on level ground, lower the implement onto the ground, and stop the engine.
2. Check the oil level through the inspection glass (1) on the front of the oil tank.

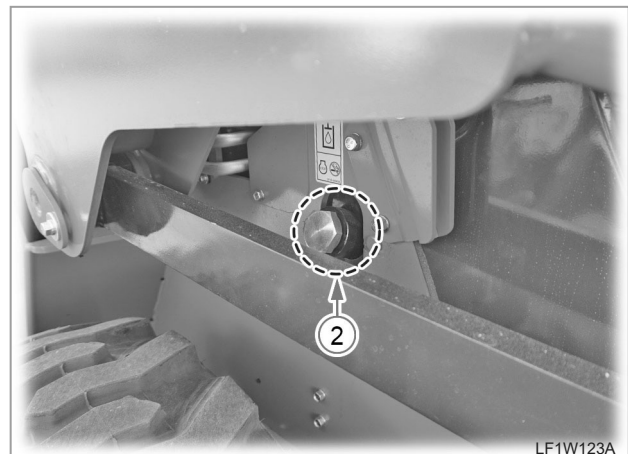

LF1W123A

3. If the oil level is low, add the specified oil through the oil filler hole (2).

Fluid oil capacity	38 ℓ (10.0 u.s.gal.)
---------------------------	----------------------

FLUID OIL CHANGE



LF1W125A

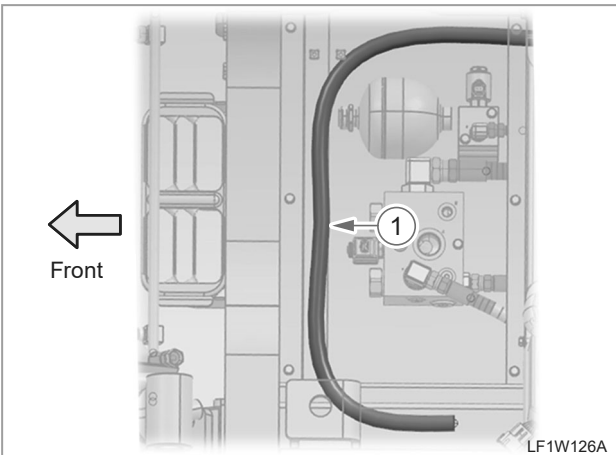

LF1W126A

1. Place a container under the drain hole on the bottom of the floor to collect oil.
2. Direct the drain hose (1) under the floor to the floor hole, remove the plug from the hose end, and drain the oil through the hole (A).

HYDRAULIC OIL FILTER REPLACEMENT



LF1W124A

(1) Hydraulic oil filter

1. The hydraulic oil filter is mounted in the engine compartment.
2. With the engine stopped and the oil having sufficiently cooled down, remove the filter by turning it counterclockwise and replace it with a new one.

8.3.5 CHAIN BOX OIL CHANGE

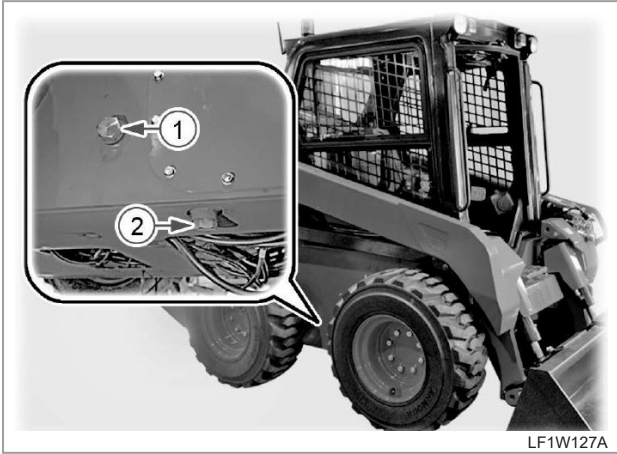

(1) Filler/ Check window (2) Drain plug

1. Park the vehicle on level ground.
2. Remove the drain plug (2), which is located between the front and rear wheels, and drain the chain box oil from the inside.
3. After tightening the drain plug completely, add a sufficient amount of the specified oil through the oil filler hole (1).

Chain box oil capacity (LH/RH)	13 ℓ (3.4 u.s.gal.)
---	---------------------

8.3.6 FAN BELT TENSION ADJUSTMENT

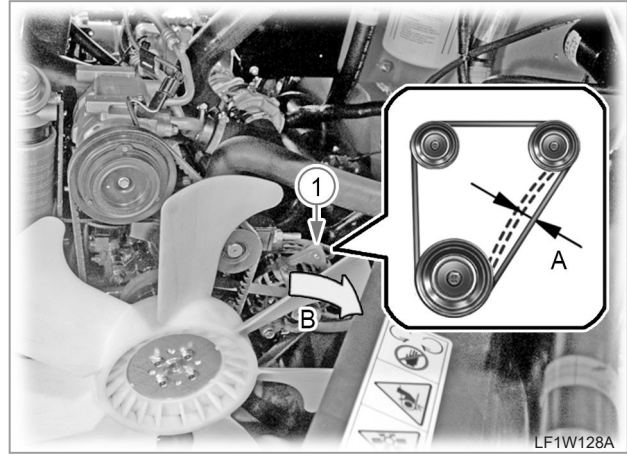

(1) Tension adjust bolt
(A) Belt tension adjust (Deflection)
(B) Pull

1. Stop the engine and remove the key from the ignition switch.
2. Check the deflection of the belt by pressing its center between the alternator pulley and the crankshaft pulley with a thumb.

Proper tension (A)	A deflection of between 7 ~ 9 mm (0.276 ~ 0.354 in.) when the belt is pressed in the middle of the span.
-------------------------------	---

3. If the tension is not proper, loosen the mounting bolt and tensioning bolt of the alternator and pull the alternator outwards (in the direction B) to adjust the tension.
4. Tighten the mounting bolt and tensioning bolt of the alternator completely.
5. If the fan belt is damaged, replace it with a new one.

REMARKS

AIR CON BELT TENSION ADJUSTMENT

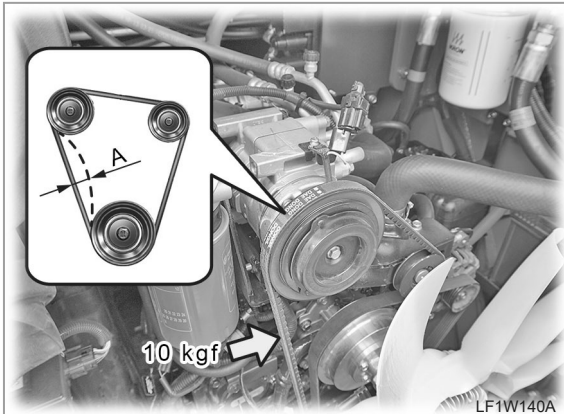

- Stop the engine and remove the key from the ignition switch.
- Apply force of 10 kgf to the A/C belt in the middle of the compressor pulley and crankshaft pulley and measure its deflection.

Proper tension (A)	When pressing the belt center with a 10 kgf of force, its deflection should be 10 ~ 12 mm (0.394 ~ 0.472 in.).
-------------------------------	--

- If the measured deflection is incorrect, loosen the tensioning bolt of the tensioner pulley in order to adjust the tension.
- If the belt is damaged, replace it with a new one.

8.3.7 AIR CLEANER CHECK

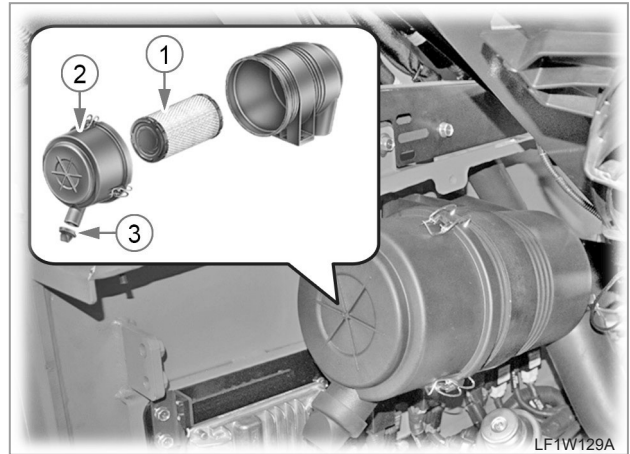

- (1) Element
- (2) Dust cap
- (3) Evacuator valve

1. Stop the engine.
2. Open the dust cap and remove the element from inside.
3. Remove dust by blowing compressed air (2 kgf/cm² or lower) from the inside toward the outside of the element.
4. If the element is contaminated by carbon or oil, replace it with a new one.
5. Open the outlet valve daily or frequently to remove any accumulated foreign material.

! IMPOARTANT

- The air cleaner will only fulfill its function if it is correctly and regularly maintained. A poorly maintained air cleaner will mean loss of power, excessive fuel consumption and a reduction in engine life.
- Be sure to refit the cover with the arrow (↑) upright. (The discharge valve should face the ground))

8.3.8 TIRE CHECK

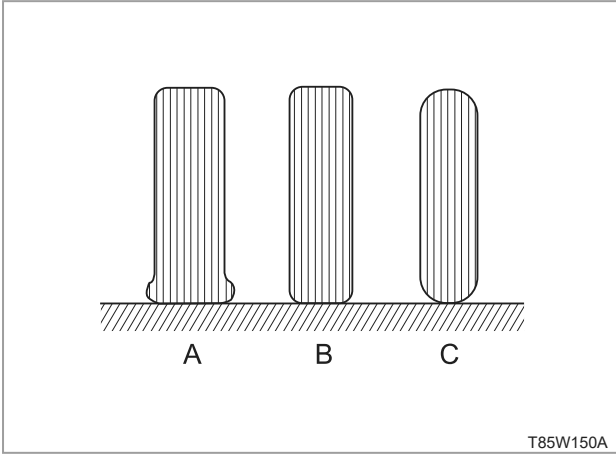

(A) Insufficient (B) Standard (C) Excessive

Though the tire pressure is factory-set to the prescribed level, it naturally drops slowly in the course of time. Thus, check it everyday and inflate as necessary.

WARNING

- Do not use tires larger than specified.
- Do not attempt to mount a tire. This should be done by a qualified person with the proper equipment.

Tire size	Inflation pressure
12 x 16.5 - 12PR	5.25 kgf/cm ² (75 psi)
10 x 16.5 - 8PR	3.87 kgf/cm ² (55 psi)

REMARKS

- Maintain the maximum pressure in front tires, if using a bucket of the front loader or when equipped with a full load of front weights.



Wheel nut (1) (M16)

Tightening torque..... 196 ~225 N.m
 20 ~ 23 kgf.m
 144 ~ 166 lb.ft

8.3.9 FUSE REPLACEMENT

VEHICLE FUSE

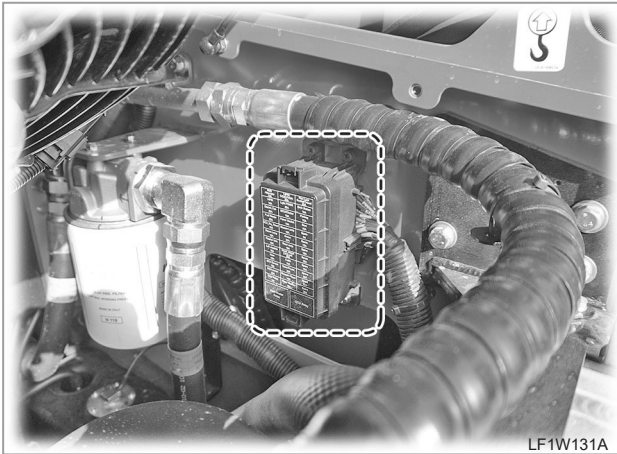

LF1W131A



LF1W144A

1. The function and capacity information of each fuse is marked on the cover of the fuse box.
2. If any of the fuses is blown, replace it with a new one of the same capacity.
3. When replacing a fuse, ensure that the ignition switch and all electric devices are turned off.

SLOW BLOW FUSE



LF1W133A

1. The slow-blow fuse protects the corresponding electric circuit for each function.
2. If any electric circuit is malfunctioning, check if the corresponding slow-blow fuse is blown.
3. Ensure to use only genuine slow-blow fuses. When its replacement is necessary, replace it with a new one with the same capacity.

Fuse	Capacity
Engine / Start	40A / 30A
Glow / Power 1	80A / 100A
Lamp / Power 2	60A / 70A

8.3.10 GREASE LUBRICATION (APPLYING PORT)

SAFETY FIRST

ENGINE

DRIVING & CHASSIS

HYDRAULIC SYSTEM

ELECTRIC SYSTEM

CABIN

INDEX

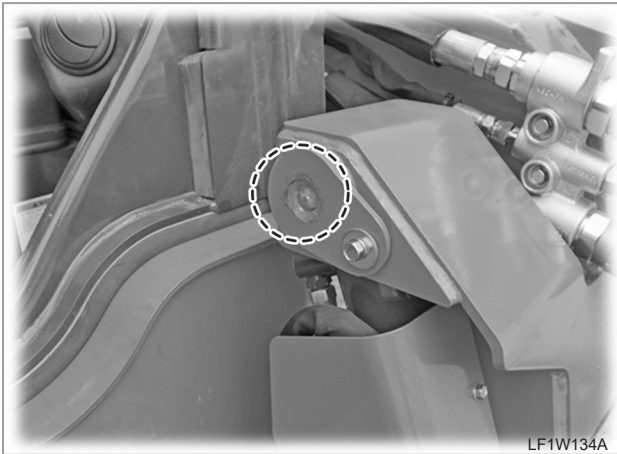

- Upper part of the bucket lift cylinder

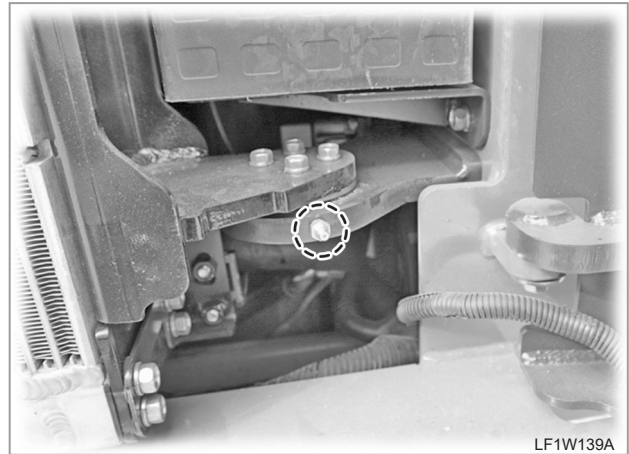

- Upper part of the opening of the engine compartment

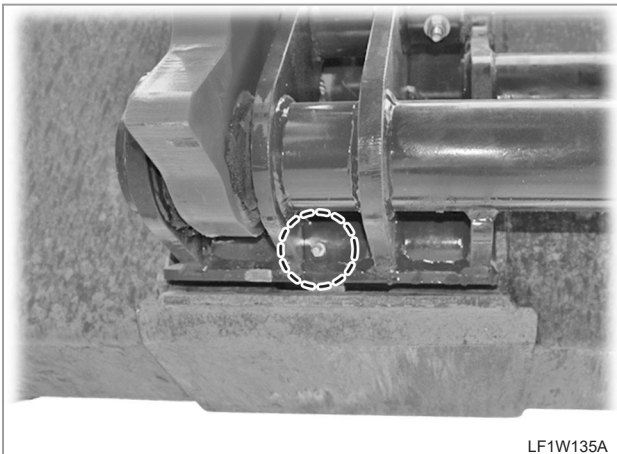

- Lower part of the bucket



- Boom cylinder
- Lower part of the bucket

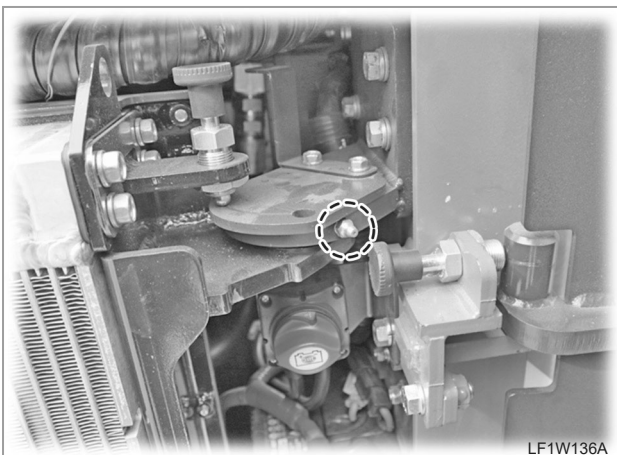

- Lower part of the opening of the engine compartment

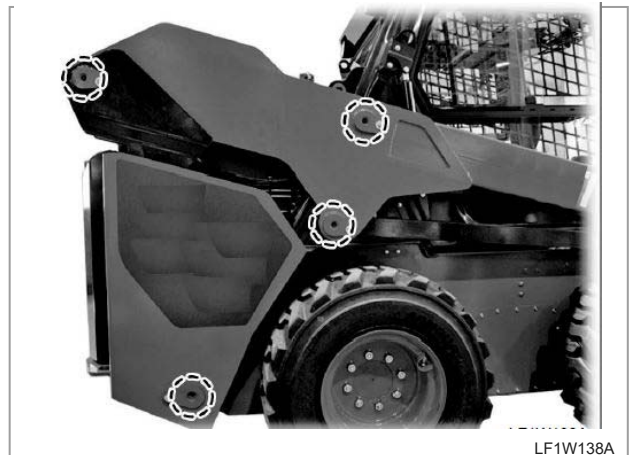

- Upper/lower parts of the boom cylinder

9. GENERAL PRECAUTIONS

9.1 ASSEMBLY AND DISASSEMBLY

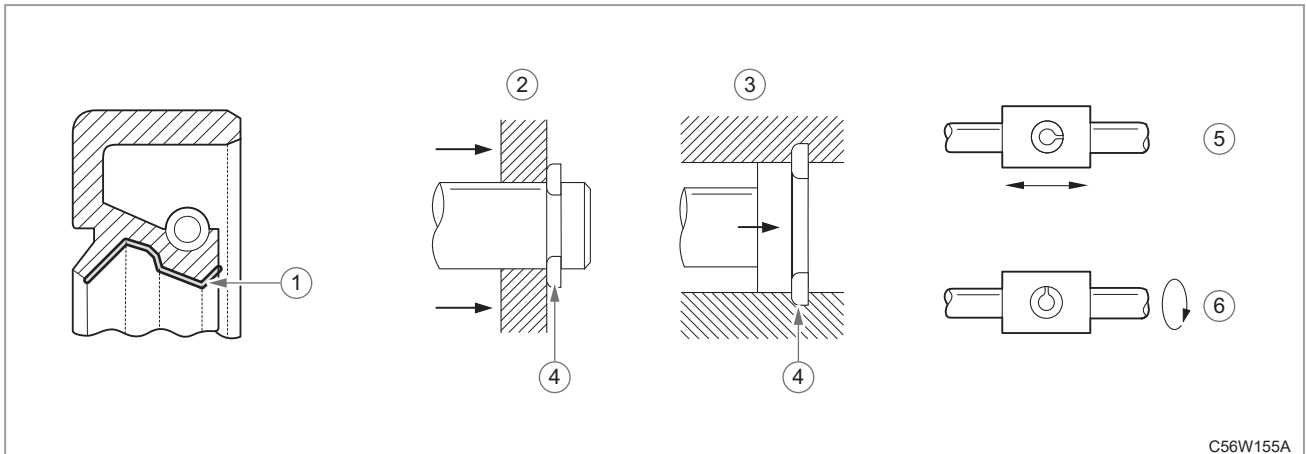

(1) Grease
(2) Snap Ring for Shaft

(3) Snap Ring for Hole
(4) Assemble Towards to be Forced

(5) Reciprocating
(6) Rotating

1. Place the tractor on firm and level ground prior to any service or adjustment.
2. Work with the engine stopped whenever possible. Be careful when doing any testing that requires the engine to be running.
3. Use only KIOTI approved special tools. Servicing dealers may machine tools to KIOTI specifications, if the tool will not be used often.
4. Keep your work area and the tractor clean during all phases of the disassembly and reassembly process.
5. After removal, keep parts clean and organized. Tighten nuts to mating bolts by hand to keep matched sets together.
6. Be careful during disassembly, assembly, and storage of hydraulic parts. Dust and metal chips can contaminate the whole hydraulic system. Keep parts covered whenever possible.
7. Use only approved manufactures cleaning agents for parts cleaning. Hydraulic parts should be cleaned with an approved cleaning oil. Diesel fuel should never be used for cleaning.
8. Remove all oil and contaminates before performing any measurement of parts.
9. Disconnect the battery negative (-) cable before removing or installing any live electrical components.
10. Use only KIOTI genuine parts to maintain the performance and safety of your KIOTI tractor.

11. When assembling an outside snap ring, on a shaft, or an inside snap ring, in a hole, assemble with the head in the direction of force. Reference the above figure.
12. When replacing a new part also replace the associated packing (gasket), bearing(s), and o-ring(s). Apply grease properly for O-rings and oil seals before assembly.
13. Locate the split portion of any spring pin by referencing the direction of force, like the above figure.
14. Replace any split pin with a new one.

! IMPOARTANT

- Use packing bond, gasket sealer, equivalent to three bond 1206D.
- Remove all existing sealer before applying new sealer to the part.
- Apply the bond, sealer, in a bead centered on the sealing flange area. If a bolt hole is encountered, continue bead to the center of the inner sealing surface.
- Assemble the parts within 10 minutes of bond, sealer, application. Wait 30 minutes before adding oil to the sealed parts, if applicable.

9.2 TUBES AND RUBBERS

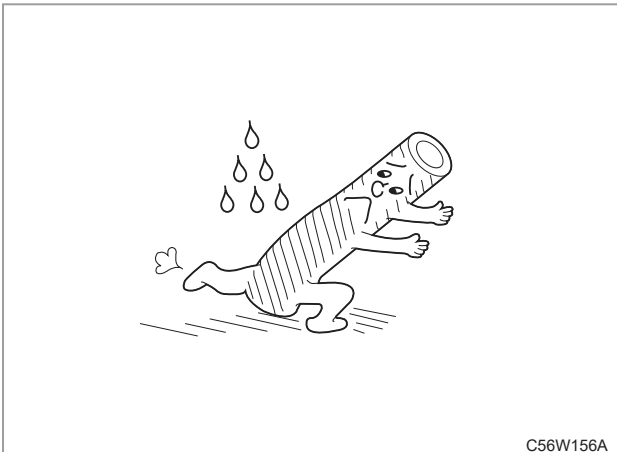

C56W156A

Keep the tubes (hoses) and rubber parts free from oil and other petroleum products. This may cause a change in quality in these parts, and may shorten product life.

9.3 LUBRICANT

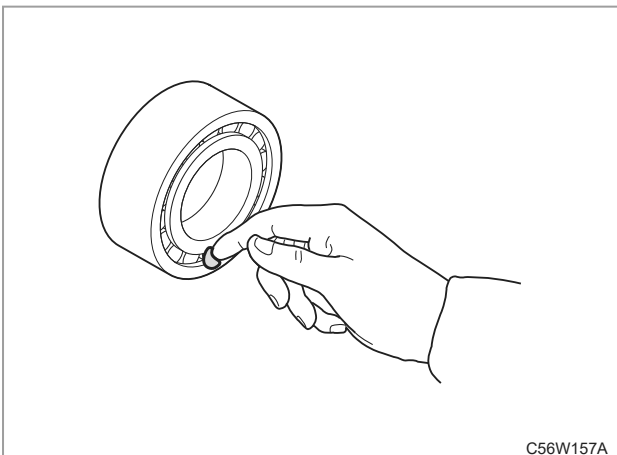

C56W157A

During assembly and repair, apply designated lubricant where specified in accordance with this repair manual.

9.4 HANDLING PRECAUTIONS FOR ELECTRICAL PARTS AND WIRING

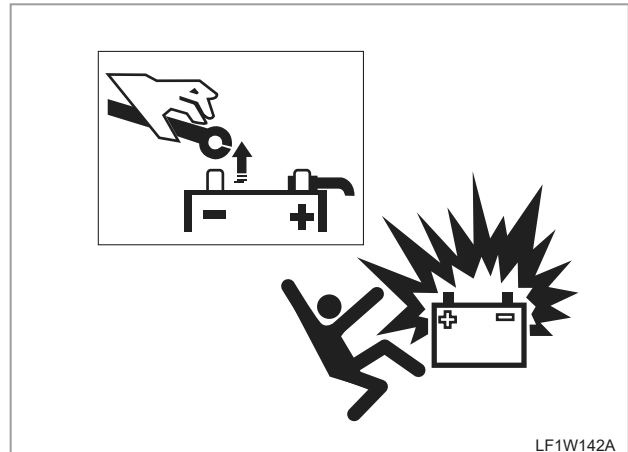

LF1W142A

- To ensure safety and prevent damage to the machine and surrounding equipment, heed the following precautions in handling electrical parts and wiring.

! IMPORTANT

- Check electrical wiring for damage and loosened connection every year. To this end, educate the customer to do his or her own check. At the same time recommend that the dealer performs a periodic check during regular maintenance.
- Do not attempt to modify or remodel any electrical parts and/ or wiring.
- When removing the battery cables, disconnect the negative cable first. When installing the battery cables, connect the positive cable first.

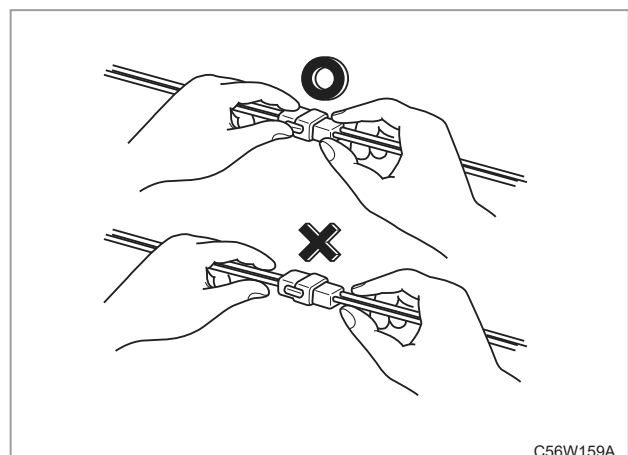

C56W159A

- Check all electrical connectors daily for any damage or short circuit at their junctions. In addition, annually schedule a complete electrical system inspection with your local KIOTI dealer.

3. Do not modify or reorganize the wiring harness or the electric field parts.
4. When disconnecting battery cables, disconnect the negative cable first. Reinstall the positive cable first when reinstalling.

REMARKS

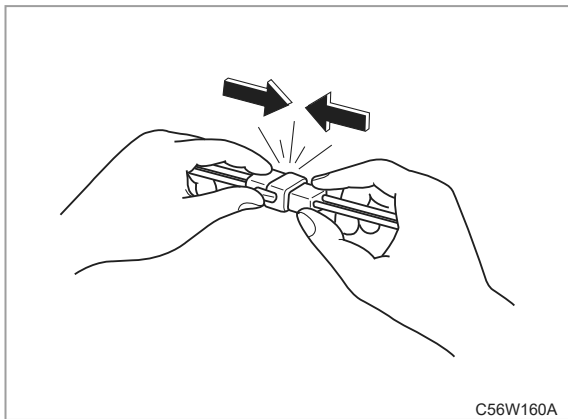

- Be sure to turn the starting key OFF when connecting or disconnecting the cable.

5. When disconnecting a connector, grasp the plastic section, not the wiring.
6. When reconnecting the connector, Insert it until it snaps.

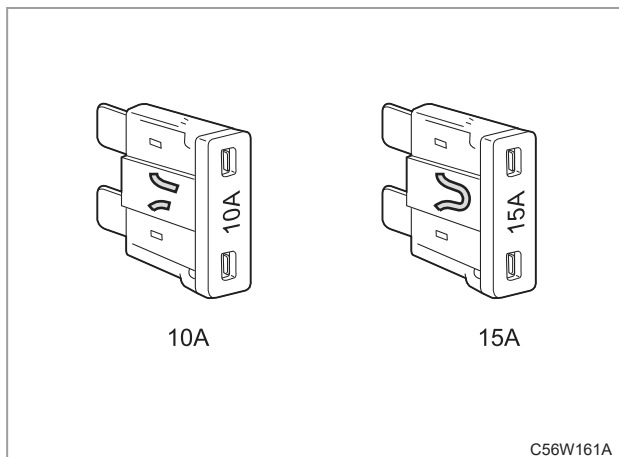

7. When replacing a broken fuse with a new one, be sure to use the fuse with the correct amperage capacity. Use your owner's manual to establish the correct capacity.
8. Be sure not to drop sensors and relays. They are fragile.

CIRCUIT TESTER

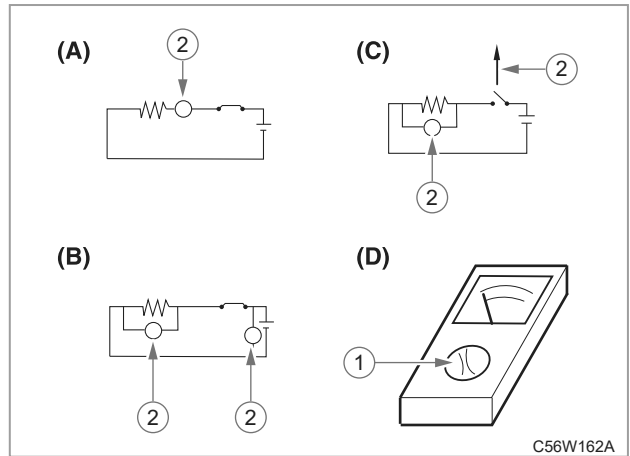

- (A) Measuring current
- (B) Measuring voltage
- (C) Measuring resistance
- (D) Setting polarity or range correctly

Use the circuit tester according to the supplied manual.

1. The current should be measured in series of resistance.
2. The voltage should be measure in parallel of resistance (with switch ON).
3. When checking whether the voltage is applied to the switch, measure the voltage between the battery (+) and the ground (with or without switch ON).
4. Make sure to turn the switch OFF when measuring the resistance.
5. The resistance should be measure in parallel of resistance (with switch OFF).
6. Set the polarity or range correctly.

OTHER PRECAUTIONS

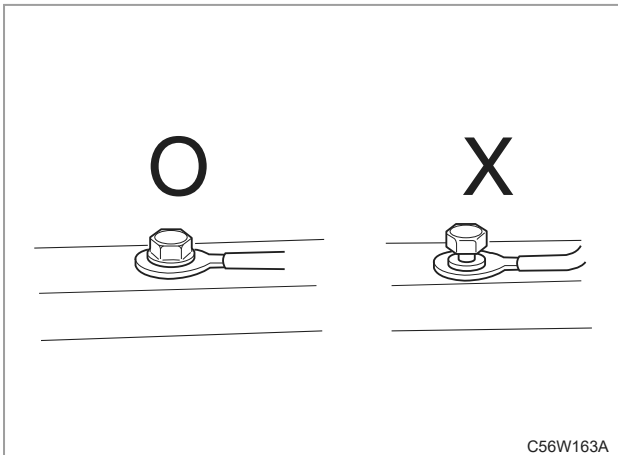

- The wiring terminal should be securely engaged.

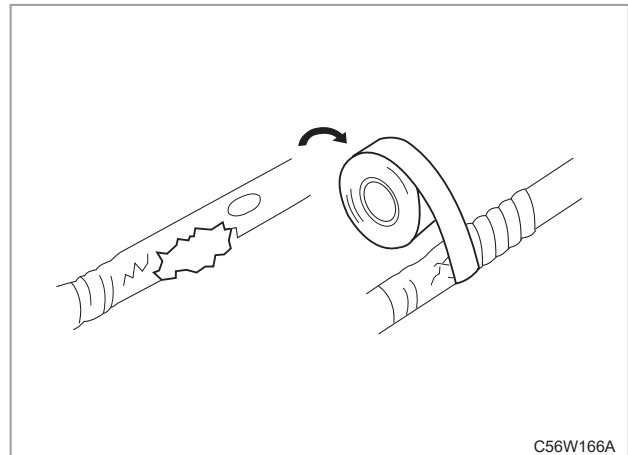

- If the wiring is damaged or aged, repair or replace it.

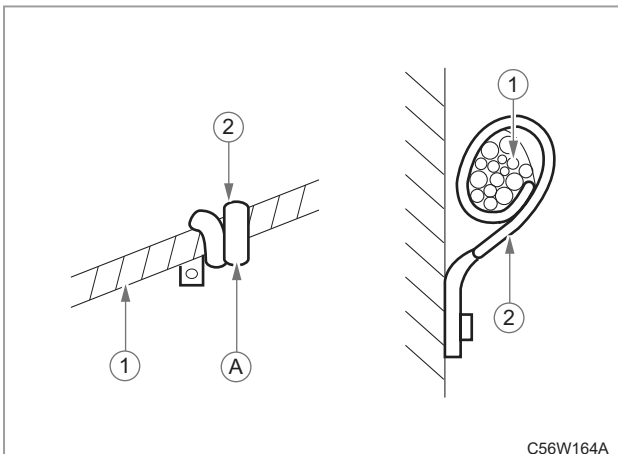

- (1) Wiring
(2) Clamp
(A) Clamping spirally

- The clamp should be firmly tightened. Also, it should not damage the wiring.

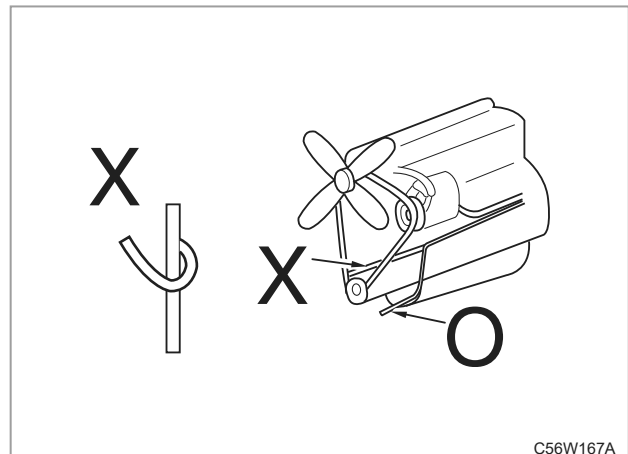

- Make sure that the wiring does not contact with a dangerous part (edge or sharp tip).

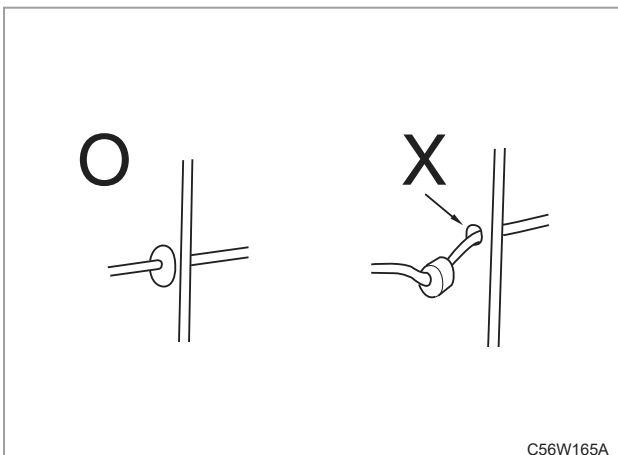

- Install the grommet firmly.

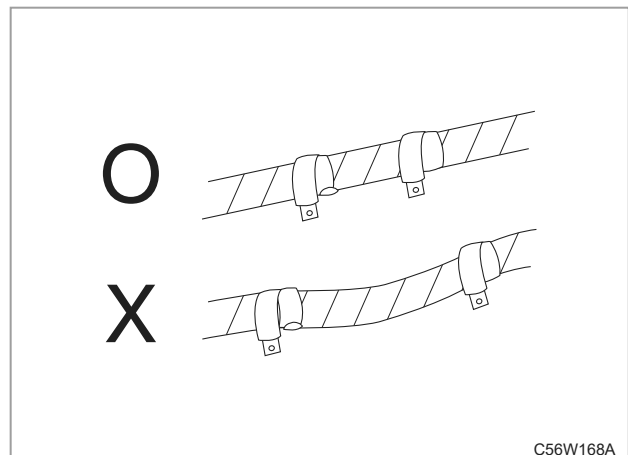



- Unnecessary pressure should not be applied to the wiring.

10. TIGHTENING TORQUE

10.1 GENERAL USE SCREWS, BOLTS AND NUTS



Screws, bolts and nuts whose tightening torques are not specified in this workshop manual should be tightened according to the table below.

Mark on bolt head	 No-grade or 4T						 7T						 9T		
Bolt material	SS400, S20C						S43C, S48C						SCr435, SCM435		
Material of component part	Steel or cast iron			Aluminum			Steel or cast iron			Aluminum			Steel or cast iron		
Unit	Nm	kgf-m	lb-ft	Nm	kgf-m	lb-ft	Nm	kgf-m	lb-ft	Nm	kgf-m	lb-ft	Nm	kgf-m	lb-ft
Type															
M6	7.85	0.80	5.79	7.85	0.80	5.79	9.81	1.00	7.24	7.85	0.80	5.79	12.3	1.25	9.05
	~	~	~	~	~	~	~	~	~	~	~	~	~	~	~
M8	17.7	1.8	13.1	16.7	1.7	12.3	23.6	2.4	17.4	17.7	1.8	13.1	29.5	3.0	21.7
	~	~	~	~	~	~	~	~	~	~	~	~	~	~	~
M10	39.3	4.0	29.0	31.4	3.2	23.2	48.1	4.9	35.5	39.3	4.0	29.0	60.9	6.2	44.9
	~	~	~	~	~	~	~	~	~	~	~	~	~	~	~
M12	62.8	6.4	46.3				77.5	7.9	57.2	62.8	6.4	46.3	103	10.5	76.0
	~	~	~				~	~	~	~	~	~	~	~	~
M14	108	11.0	79.6				124	12.6	91.2				167	17.0	123
	~	~	~				~	~	~				~	~	~
M16	167	17.0	123				197	20.0	145				260	26.5	192
	~	~	~				~	~	~				~	~	~
M18	246	25.0	181				275	28.0	203				344	35.0	254
	~	~	~				~	~	~				~	~	~
M20	334	34.0	246				368	37.5	272				491	50.0	362
	~	~	~				~	~	~				~	~	~
	392	40.0	289				431	44.0	318				568	58.0	419

10.2 STUD BOLTS

Material of component part	Steel or cast iron			Aluminum		
Unit	Nm	kgf-m	lb-ft	Nm	kgf-m	lb-ft
Diameter						
M8	11.6 ~ 15.6	1.2 ~ 1.6	8.68 ~ 11.5	8.82 ~ 11.6	0.90 ~ 1.2	6.51 ~ 8.67
M10	24.6 ~ 31.3	2.5 ~ 3.2	18.1 ~ 23.1	19.7 ~ 25.4	2.0 ~ 2.6	14.5 ~ 18.8
M12	34.3 ~ 49.0	3.5 ~ 5.0	25.2 ~ 36.1	31.4	3.2	23.1
M14	61.7 ~ 73.5	6.3 ~ 7.5	45.4 ~ 54.0	-		
M16	98.0 ~ 112.7	10.0 ~ 11.5	72.0 ~ 82.8	-		

10.3 AMERICAN STANDARD SCREWS, BOLTS AND NUTS WITH UNC OR UNF THREADS

Grade Unit Diameter	SAE GR.5 			SAE GR.5 		
	Nm	kgf-m	lb-ft	Nm	kgf-m	lb-ft
5/16	23.1 ~ 27.8	2.35 ~ 2.84	17.0 ~ 20.5	32.5 ~ 39.3	3.31 ~ 4.01	24.0 ~ 29.0
3/8	47.5 ~ 57.0	4.84 ~ 5.82	35.0 ~ 42.0	61.0 ~ 73.2	6.22 ~ 7.47	45.0 ~ 54.0
1/2	108.5 ~ 130.2	11.07 ~ 13.29	80.0 ~ 96.0	149.2 ~ 179.0	15.22 ~ 16.27	110.0 ~ 132.0
9/16	149.2 ~ 179.0	15.22 ~ 18.27	110.0 ~ 132.0	217.0 ~ 260.4	22.14 ~ 26.57	160.0 ~ 192.0
5/8	203.4 ~ 244.1	20.75 ~ 24.91	150.0 ~ 180.0	298.3 ~ 358.0	30.44 ~ 36.53	220.0 ~ 264.0

10.4 HIGH PRESSURE HOSE UNION NUT

Hose size (Inner diameter: inch)	1/8"	3/16"	1/4"	5/16"	3/8"	1/2"	5/8", 3/4"	1"
Screw size (PF)	1/8"	1/4"	1/4"	3/8"	3/8"	1/2"	3/4"	1"
Tightening torque (kg.m)	1	2.5	2.5	5	5	6	12	14

10.5 O-RING FACE TYPE SCREW

Screw size (UN)	9/16-18	11/16-16	13/16-16	1 · 3/16-12	1 · 7/16-12
Tightening torque (kg.m)	2.5 ~ 3.0	3.8 ~ 4.3	6.0 ~ 6.5	12.0 ~ 13.0	18.5~19.5
Hose spec (Ref)	1/4"	3/8"	1/2"	3/4"	1"

10.6 FITTING FIXING SCREW

Screw size (UN)	7/16-20	9/16-18	3/4-16	7/8-14
Tightening torque (kg.m)	2.0 ~ 2.2	3.4 ~ 3.6	7.0 ~ 7.8	10 ~ 11.2
Screw size (UN)	1 · 1/16-12	1 · 3/16-12	1 · 5/16-12	1 · 5/8-12
Tightening torque (kg.m)	17.4 ~ 18.7	22.0 ~ 25.0	27.6 ~ 30.6	29.1 ~ 33.8
Screw size (UN)	PF 1/4	PF 1/2	PF 3/4	
Tightening torque (kg.m)	2.55~3.06	7.65~9.69	14.29~16.33	

11. PART NUMBER ASSIGNMENT STANDARD FOR HYUNDAI BOLTS AND NUTS
11.1 PART NUMBER ASSIGNMENT STANDARD FOR BOLTS

0 1 1 3 3 - 5 1 0 5 5

Length: 55 mm

※ In case the bolt length is over 100 mm, its length is identified by the last number.

100	105	110	115	120	125	Calculation: If the length is 130 mm (130 - 100) ÷ 5 = 06
00	01	02	03	04	05	

Bolt size: M10

Plating

5	MFZn5-C (Electric zinc)
6	MFZn5-G (Green chromate)
0	No plating

Hardness and thread

0	4T	Partial thread	* Hardness is shown on the head of bolt. (with number or punching)
2	4T	Full thread	
3	7T	Partial thread	
5	7T	Full thread	
6	9T	Partial thread	

Spring washer and pitch

No.	Spring washer	Pitch	M5	M6	M8	M10	M12	M14	M16	M18	M20
2	Yes	Regular	0.8	1	1.25	1.5	1.75	2	2	2.5	2.5
3	Yes	Fine	-	-	1	1.25	1.25	1.5	1.5	1.5	1.5
5	No	Regular	0.8	1	1.25	1.5	1.75	2	2	2.5	2.5
7	No	Fine	-	-	1	1.25	1.25	1.5	1.5	1.5	1.5

Head size (mm)

No.	Type	M5	M6	M8	M10	M12	M14	M16	M18	M20
0	Regular	8	10	13	17	19	22	24	27	30
1	Small	-	-	12	14	17	19	22	24	27

Part name (bolt)

Example) 01120-50850

This is 4T partial thread screw which its spring washer thread pitch is 1.25 mm, head size is 12 mm, diameter is 8 mm and length is 50 mm.

11.2 PART NUMBER ASSIGNMENT STANDARD FOR KIOTI NUTS

0 2 1 1 4 - 5 0 0 8 0

Nut size: M8

Plating number

5	MFzn5-C (Electric zinc plated)
6	MFzn5-GR (Electric flat chrome plated)
0	No plating

Hardness, pitch, width

ITEM	HARD-NESS	SCREW	HEIGHT	REMARKS
54	4T	Regular	Type 2	<ul style="list-style-type: none"> • Height <ul style="list-style-type: none"> - Type 2: longer - Type 3: shorter • Hardness <ul style="list-style-type: none"> - For 6T nut, its hardness is indicated in number or chromometric method. - For 4T nut, its hardness is not usually indicated.
52	4T	Regular	Type 3	
74	4T	Fine	Type 2	
72	4T	Fine	Type 3	
14	4T	Regular	Type 2	
12	4T	Regular	Type 3	
56	6T	Regular	Type 2	
18	4T	Fine	Type 2	
16	4T	Fine	Type 3	
76	6T	Fine	Type 2	

Cross distance

0	Regular
1	Small

Part name: nut

► NUT SPECIFICATION STANDARD TABLE

ITEM		No.	M5	M6	M8	M10	M12	M14	M16	M18	M20	M22
Pitch	Regular	-	1	1	1.25	1.5	1.75	2	2	2.5	2.5	2.5
	Fine	-	-	-	1	1.25	1.25	1.5	1.5	1.5	1.5	1.5
Cross distance	Regular	0	8	10	13	17	19	22	24	27	30	32
	Small	1	-	-	12	14	17	19	22	24	27	30
Height	Type 2	-	4	5	6.5	8	10	11	13	15	16	18
	Type 3	-	3	3.6	5	6	7	8	10	11	12	13

12. UNIT CONVERSION TABLE

TORQUE			LENGTH		VOLUME		PRESSURE			TEMPERATURE	
Kgf-m	Nm	lb-ft	Inch	mm	ℓ	U.S.gal.	kgf/cm ²	kPa	PSI	°C	°F
1	9.8	7.2	1	25.4	1	0.26418	1	98	14.22	-20	-4
2	19.6	14.5	2	50.8	2	0.5	10	980	142.2	-15	5
3	29.4	21.7	3	76.2	4	1.1	20	1960	284.4	-10	14
4	39.2	28.9	4	101.6	6	1.6	30	2940	426.6	-5	23
5	49	36.2	5	127	8	2.1	40	3920	568.8	0	32
6	58.8	43.4	6	152.4	10	2.6	50	4900A	711	5	41
7	68.6	50.6	7	177.8	12	3.2	60	5880	853.2	10	50
8	78.4	57.9	8	203.2	14	3.7	70	6860	995.4	15	59
9	88.2	65.1	9	228.6	16	4.2	80	7840	1137.6	20	68
10	98	72.3	10	254	18	4.8	90	8820	1279.8	25	77
11	107.8	79.6	11	279.4	20	5.3	100	9800	1422	30	86
12	117.6	86.8	12	304.8	22	5.8	110	10780	1564.2	35	95
13	127.4	94.0	13	330.2	24	6.3	120	11760	1706.4	40	104
14	137.2	101.3	14	355.6	26	6.9	130	12740	1848.6	45	113
15	147	108.5	15	381	28	7.4	160	15680	2275.2	50	122
16	156.8	115.7	16	406.4	30	7.9	170	16660	2417.4	55	131
17	166.6	123.0	17	431.8	32	8.5	180	17640	2559.6	60	140
18	176.4	130.2	18	457.2	34	9.0	190	18620	2701.8	65	149
19	186.2	137.4	19	482.6	36	9.5	200	19600	2844	70	158
20	196	144.7	20	508	38	10.0	225	22050	3199.5	75	167
21	205.8	151.9	21	533.4	40	10.6	250	24500	3555	80	176
22	215.6	159.1	22	558.8	42	11.1	275	26950	3910.5	85	185
23	225.4	166.4	23	584.2	44	11.6	300	29400	4266	90	194
24	235.2	173.6	24	609.6	46	12.2	325	31850	4621.5	95	203
25	245	180.8	25	635	48	12.7	350	34300	4977	100	212

SAFETY FIRST

ENGINE

DRIVING & CHASSIS

HYDRAULIC SYSTEM

ELECTRIC SYSTEM

CABIN

INDEX

