

---

**TABLE OF CONTENTS**

---

<b>1. ENGINE IDENTIFICATION .....</b>	<b>2-3</b>		
1.1 Engine EPA decal (A).....	2-3		
1.2 Engine number.....	2-3		
1.3 Assignment standard for engine model code...	2-4		
<b>2. SPECIFICATIONS.....</b>	<b>2-5</b>		
2.1 General specifications .....	2-5		
2.2 Engine dimension .....	2-6		
2.3 Components .....	2-7		
2.4 Engine performance curve .....	2-8		
2.5 Engine performance curve analysis .....	2-9		
2.5.1 Torque .....	2-9		
2.5.2 Brake horse power (HP) .....	2-9		
2.5.3 S.F.C (Specific Fuel Consumption) (for reference only) .....	2-10		
2.6 Servicing specifications .....	2-11		
2.6.1 Engine body .....	2-11		
2.6.2 Lubricating system.....	2-14		
2.6.3 Cooling system .....	2-14		
2.6.4 Tightening torques for engine.....	2-15		
<b>3. OPERATING PRINCIPLE .....</b>	<b>2-16</b>		
3.1 CRDI (Common Rail Direct Injection) system...	2-16		
3.1.1 ECU(Electronic Control Unit).....	2-18		
3.1.2 High pressure fuel pump (for injection)...	2-27		
3.1.3 Fuel rail(Common rail).....	2-28		
3.1.4 Injector [C3I].....	2-28		
3.2 Body and power train system .....	2-32		
3.2.1 Cylinder head .....	2-32		
3.2.2 Cylinder block .....	2-33		
3.2.3 Cylinder honing.....	2-33		
3.2.4 Crankshaft .....	2-33		
3.2.5 Piston and piston ring .....	2-33		
3.2.6 Connecting rod .....	2-34		
3.2.7 Camshaft .....	2-34		
3.2.8 Rocker arm assembly.....	2-34		
3.2.9 Intake and exhaust valves .....	2-35		
3.2.10 Timing gear .....	2-35		
3.2.11 Flywheel .....	2-36		
3.2.12 MLS cylinder head gasket.....	2-36		
3.3 Lubricating system.....	2-37		
3.3.1 Engine oil flow .....	2-37		
3.3.2 Engine oil flow chart .....	2-38		
3.3.3 Function of lubricating system .....	2-39		
3.4 Cooling system .....	2-41		
3.4.1 Coolant flow route .....	2-41		
3.4.2 Water pump .....	2-42		
3.4.3 Thermostat.....	2-42		
3.4.4 Radiator .....	2-43		
3.4.5 Radiator cap .....	2-43		
3.4.6 Clutch fan.....	2-44		
3.5 Fuel system.....	2-46		
3.5.1 Overview for fuel supply.....	2-46		
3.5.2 Fuel flow route .....	2-46		
3.5.3 Fuel filter .....	2-48		
3.5.4 Bleeding the fuel system.....	2-49		
3.5.5 High pressure fuel pump .....	2-50		
3.5.6 Common rail (Fuel rail) .....	2-52		
3.5.7 Injector [C3I (Calibration Improved Individual Injector)].....	2-53		
3.5.8 Fuel heater and fuel cooler .....	2-54		
3.6 Acceleration system.....	2-55		
3.7 Intake & Exhaust system .....	2-57		
3.7.1 Overview.....	2-57		
3.7.2 EGR cooler.....	2-59		
3.7.3 EGR valve .....	2-59		
3.7.4 Air control valve.....	2-61		
3.7.5 CCRT (Catalyzed Continuously Regenerating Trap).....	2-62		
3.7.6 Turbo charger.....	2-67		
3.8 Sensor.....	2-68		
3.8.1 Sensors as input/output for ECU .....	2-71		

---

---

# TABLE OF CONTENTS

---

<b>4. TROUBLESHOOTING .....</b>	<b>2-72</b>	<b>7. DISASSEMBLY, SERVICE AND ASSEMBLY .....</b>	<b>2-103</b>
<b>5. MEASUREMENT AND ADJUSTMENT.</b>	<b>2-75</b>	7.1 Engine removal.....	2-103
5.1 Fan belt .....	2-75	7.2 Assembling the engine.....	2-118
5.2 Piston compression pressure measurement...	2-75	7.3 Engine component removal .....	2-135
5.3 Valve clearance .....	2-76	7.4 Engine disassembly .....	2-141
5.3.1 4 CYL. ....	2-76	7.4.1 Head cover .....	2-141
5.4 Valve lift (Deflection and worn condition of valve cam, tappet, push rod, rocker arm, etc.).....	2-77	7.4.2 Glow plug and injector .....	2-142
5.5 Oil pressure measurement .....	2-78	7.4.3 Rocker arm assembly .....	2-143
5.6 Bubble test for radiator .....	2-78	7.4.4 Cylinder head .....	2-145
5.7 Turbo charger wastegate pressure check...	2-79	7.4.5 Intake and exhaust valves.....	2-147
<b>6. EXPLODED VIEW .....</b>	<b>2-80</b>	7.4.6 High pressure fuel pump.....	2-149
6.1 EH5-G111001 Cylinder block group.....	2-80	7.4.7 Gear case.....	2-150
6.2 EH5-G113003 Cylinder head group .....	2-81	7.4.8 Gears in gear case.....	2-151
6.3 EH5-G114002 Gear case group .....	2-82	7.4.9 Piston and connecting rod .....	2-160
6.4 EH5-G121001 Crank shaft group .....	2-83	7.4.10 Flywheel and crankshaft.....	2-165
6.5 EH5-G122001 Piston connecting rod group...	2-84	7.4.11 Oil filter.....	2-174
6.6 EH5-G123001 Camshaft group .....	2-85	7.4.12 Oil pump .....	2-175
6.7 EH5-G124002 Idle gear group.....	2-86	7.4.13 Thermostat .....	2-177
6.8 EH5-G125001 Rocker arm valve group....	2-87	7.4.14 Water pump .....	2-178
6.9 EH5-G131001 Intake manifold group .....	2-88	7.4.15 Fuel filter .....	2-180
6.10 EH5-G134001 Turbo group.....	2-89	7.4.16 Turbo charger .....	2-180
6.11 EH5-G135001 Turbo pipe group .....	2-90	<b>8. DIAGNOSIS .....</b>	<b>2-184</b>
6.12 EH5-G141001 Oil pump group .....	2-91	8.1 Diagnostic program.....	2-184
6.13 EH5-G144001 Oil filter group.....	2-92	8.2 DTC (Diagnostic Trouble Code).....	2-210
6.14 EH5-G151001 Fuel equipment group.....	2-93	8.2.1 Composition .....	2-210
6.15 EH5-G162001 Water flange group.....	2-94	8.2.2 Error code & action.....	2-211
6.16 EH5-G163003 Water pump group .....	2-95	8.2.3 Fault diagnosis code description...	2-225
6.17 EH5-G171001 EGR group.....	2-96		
6.18 EH5-G172001 EGR cooler group .....	2-97		
6.19 EH5-G191002 Glow plug group .....	2-98		
6.20 EH5-G192001 Engine electrical group...	2-99		
6.21 EH5-G194001 ECU group.....	2-100		
6.22 LF1-G012002 Cooling fan group .....	2-101		
6.23 LF1-G014001 Aftertreatment group .....	2-102		

---



## 1. ENGINE IDENTIFICATION

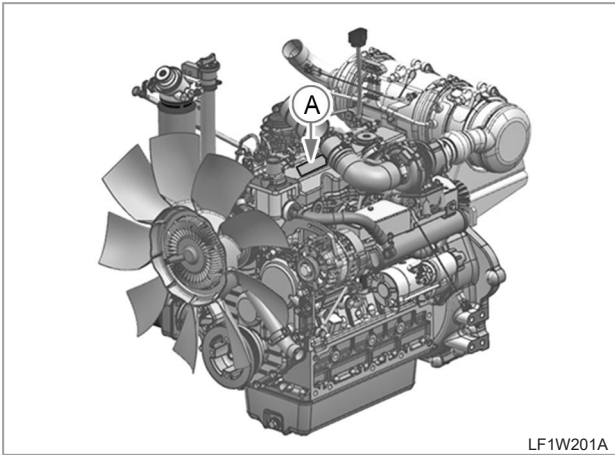

LF1W201A

### 1.1 ENGINE EPA DECAL (A)

This aluminum decal is riveted on the engine cylinder head cover. This provides the information such as engine model, rated output, etc.

### 1.2 ENGINE NUMBER

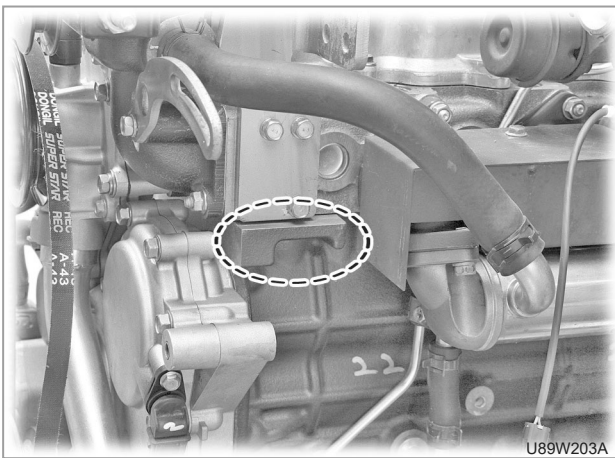

U89W203A

The engine number is recorded with a vibration pen on the surface of the cylinder block behind the alternator in case the barcode is damaged.

#### **!** IMPOARTANT

- The engine number is necessary information that is requested on the warranty registration form. This number should be on the form as well as the tractor number and the amount of time used.

1.3 ASSIGNMENT STANDARD FOR ENGINE MODEL CODE

4 H T I 4

SAFETY FIRST

ENGINE

DRIVING & CHASSIS

HYDRAULIC SYSTEM

ELECTRIC SYSTEM

CABIN

INDEX

→ Emission control category

3	Tier 3
4	Tier 4
5	Stage-V

→ Engine type

-	N/A type
T	Turbo charger type
TI	Turbocharger + Intercooler

→ Stroke(행정)

A	92.4 mm (3.638 in.)
B	102.4 mm (4.031 in.)
F, H	102.4 mm (4.031 in.), Ladder Frame Block

→ Number of cylinders

3	3 cylinders
4	4 cylinders

**2. SPECIFICATIONS**

**2.1 GENERAL SPECIFICATIONS**

Engine model		4HT14
Bore I.D. X Stroke	(mm)	Ø 87×102.4
Honing		PLATEAU honing
Number of cylinders		4
Ignition sequence		1-3-4-2
Displacement	(ℓ)	2.435
Speed	(rpm)	2,400
Max. gross output	kW(HP)/rpm	54.9 (73.6) / 2,400
Max. torque	Nm/rpm	274/1,500
Compression ratio		17.4:1
Combustion chamber type		Direct injection type Turbo charged
High pressure fuel pump type		Delphi DFP 4.6.18 TP
Injection pressure	bar	Max. 1,800
Engine oil capacity	(ℓ)	9.0 (with filter)
Engine oil specification		SAE 15W 40, API Classification CJ or higher
Coolant capacity	(ℓ)	4.2 (Engine only)
Anti-freeze		Ethylene glycol 50% with anti-corrosive agent

- The engine gross output is measured with the cooling fan removed.
- The cylinder number for ignition sequence is given from the cylinder on the engine cooling fan side.
- If the coolant level drops due to its evaporation, add only water. If the coolant lever drops due to the leakage, add coolant mixed with anti-freeze.
- The freezing point of the 50% coolant mixture is -37°C (-34°F) in a normal condition.
- When replacing the coolant with a different type of coolant, flush the cooling system thoroughly beforehand.

2.2 ENGINE DIMENSION

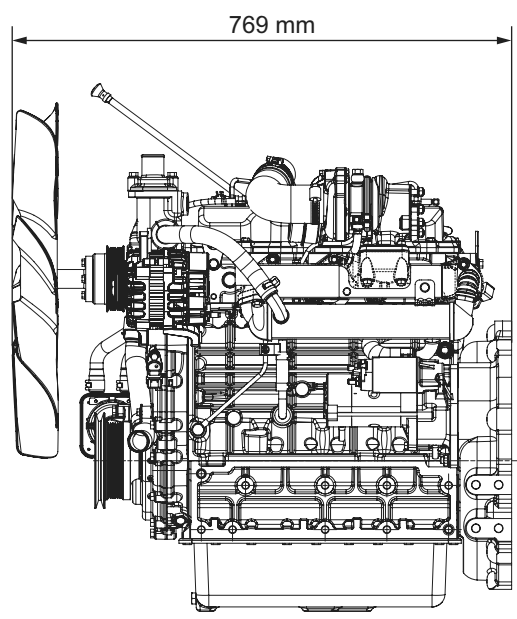
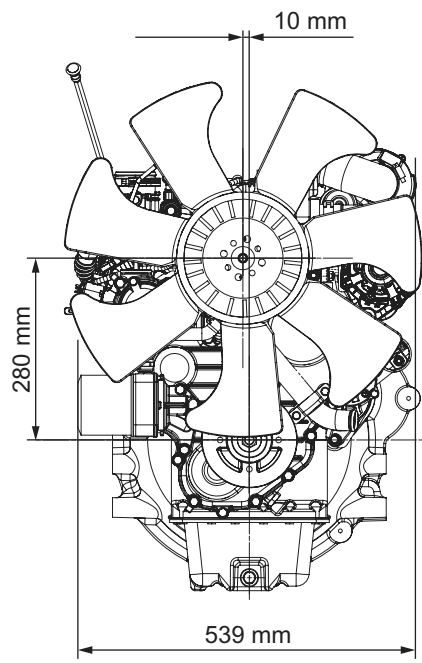
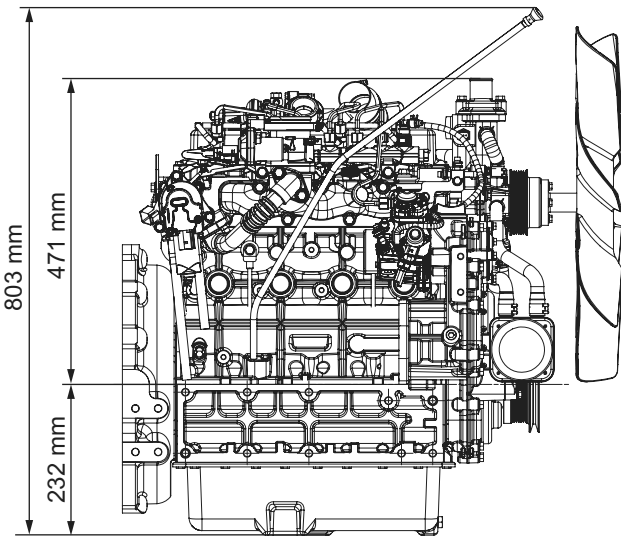

LF1W209A

SAFETY FIRST

ENGINE

DRIVING & CHASSIS

HYDRAULIC SYSTEM

ELECTRIC SYSTEM

CABIN

INDEX

2.3 COMPONENTS

SAFETY FIRST

ENGINE

DRIVING & CHASSIS

HYDRAULIC SYSTEM

ELECTRIC SYSTEM

CABIN

INDEX

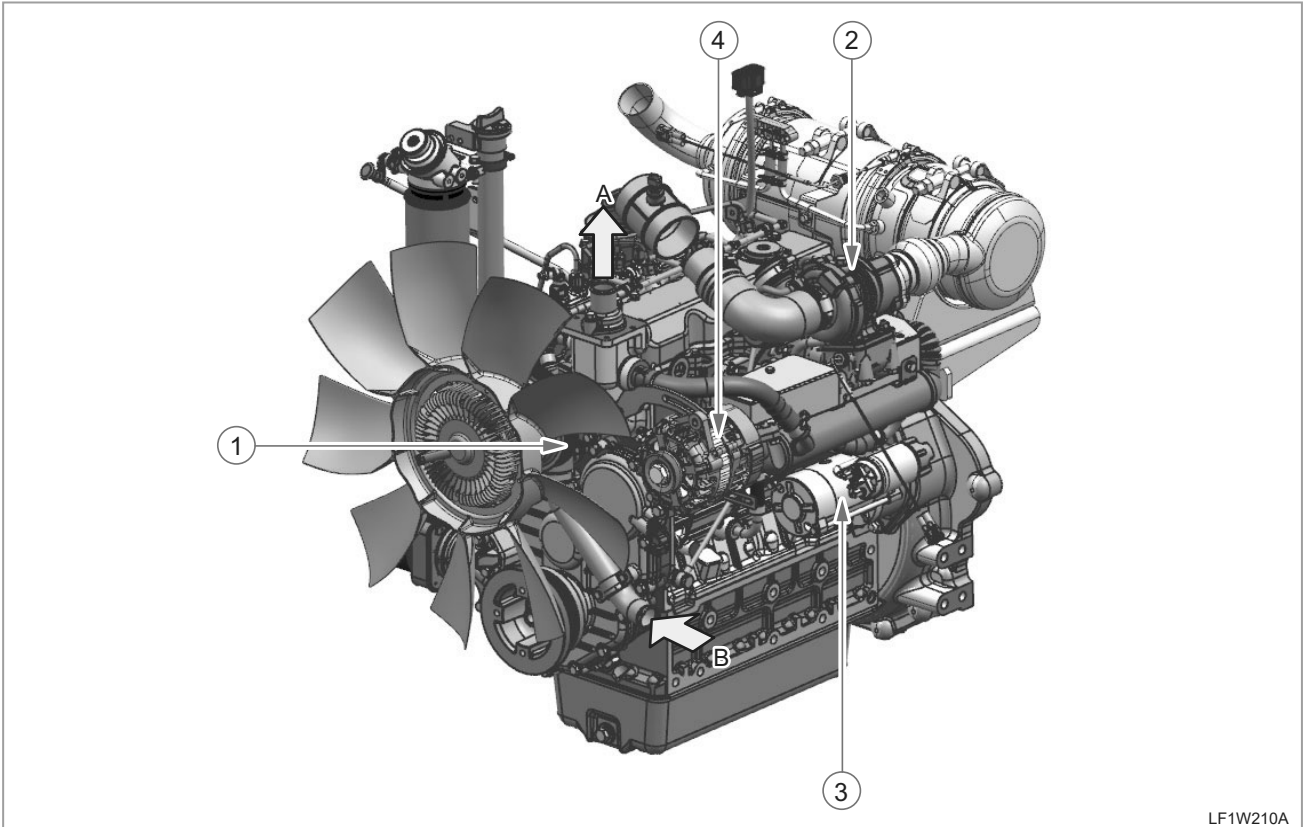

LF1W210A

- (1) Water pump
- (2) Turbocharger

- (3) Starter
- (4) Alternator

- (A) Coolant out (to radiator)
- (B) Coolant in (from radiator)

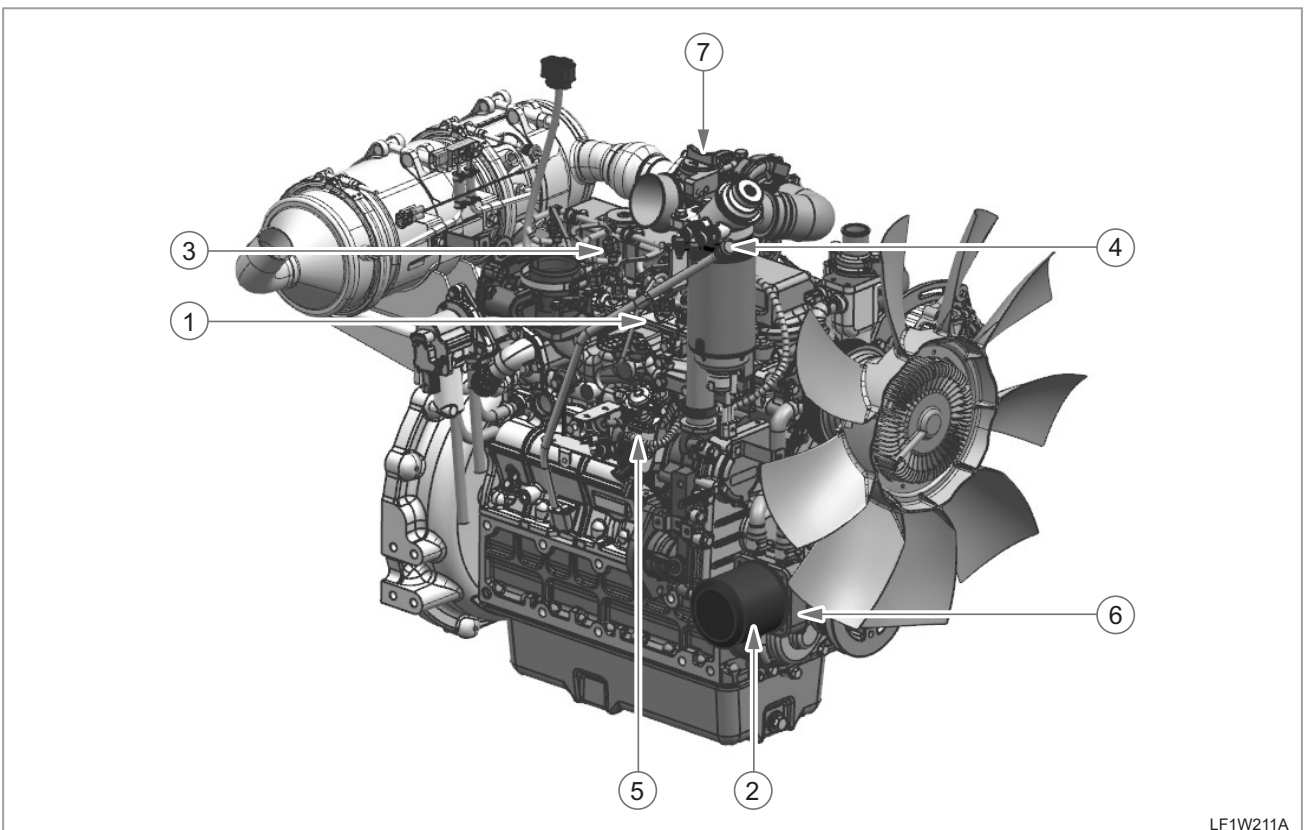

LF1W211A

- (1) Common rail
- (2) Oil filter
- (3) Injector

- (4) Oil gauge
- (5) HP Pump
- (6) Oil cooler

- (7) Oil filler

2.4 ENGINE PERFORMANCE CURVE

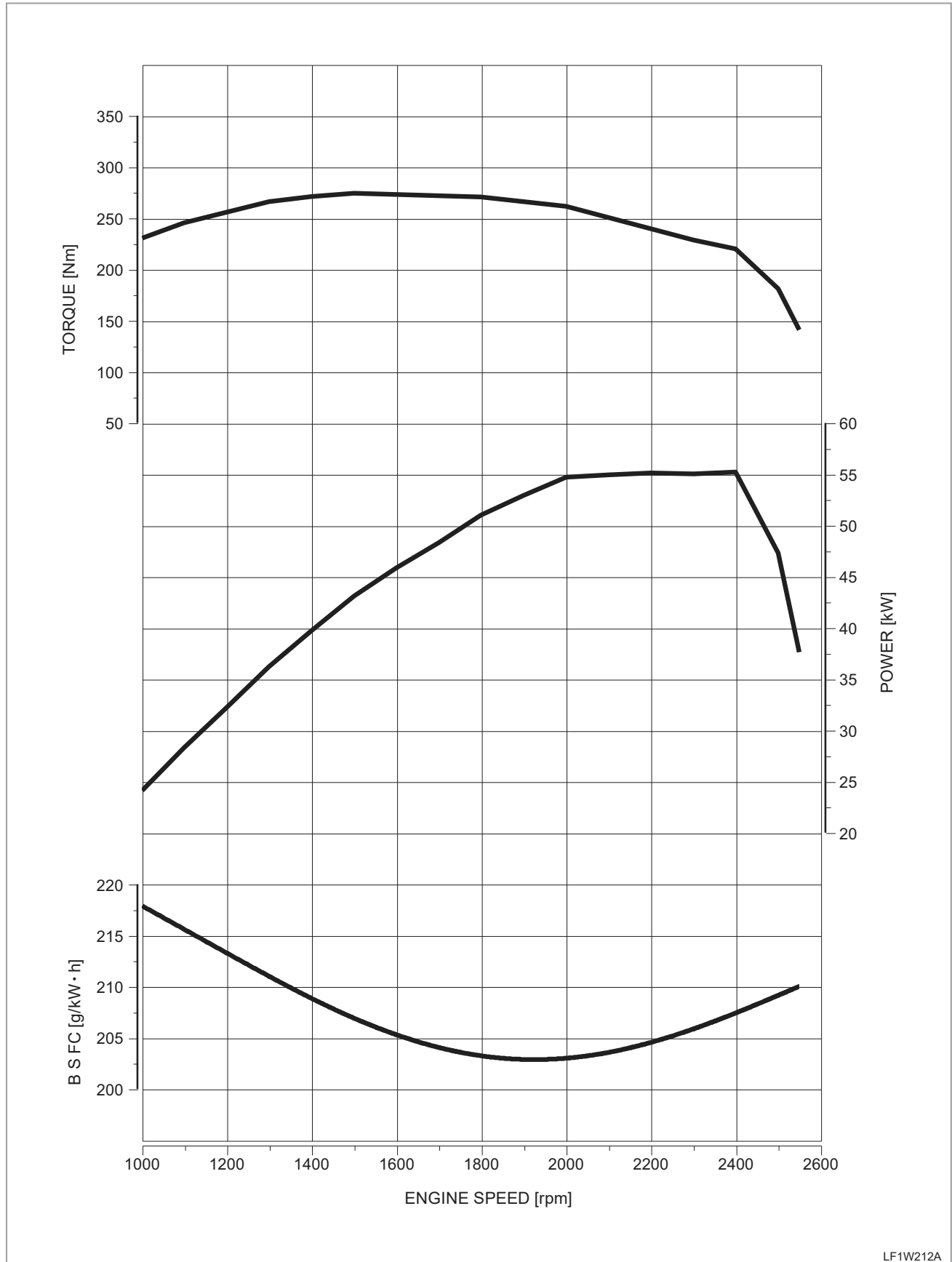

LF1W212A

SAFETY FIRST

ENGINE

DRIVING & CHASSIS

HYDRAULIC SYSTEM

ELECTRIC SYSTEM

CABIN

INDEX

2.5 ENGINE PERFORMANCE CURVE ANALYSIS

2.5.1 TORQUE

When applying the rotating resistance to the flywheel, the engine speed drops and the rotating force of flywheel increases.

Torque curve shows this force as a graph.

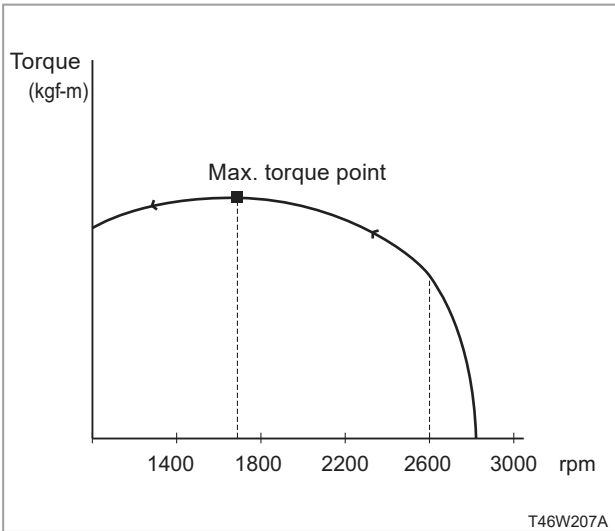

When running the engine at full speed without load, the engine rotates at approx. 2,800 rpm as shown in the figure. When the resistance is applied to the flywheel by braking with some kind of dynamometer, the rotating force of the dynamometer increases (arrow direction) as shown in the figure. In this case, the engine speed gradually decreases. When the engine speed reaches approx. 1,700 rpm, the torque starts to decrease. In other words, this point (1,700 rpm) is the maximum torque point.

2.5.2 BRAKE HORSE POWER (HP)

The power is proportional to the rotating force (torque) and the rotating speed (RPM). Its formula is as follows:

$$\text{Power (HP)} = \frac{\text{Torque(kgf-m)} \times \text{rpm}}{725.7}$$

1 kW = 1.341 HP

If substituting the torque and RPM in the left figure for the above formula and getting the power value, the below curve is provided. As shown in the below figure, when the power reaches the maximum point at 2,600 rpm, the power starts to drop. This is because the rpm drops sharply even the torque increases gradually.

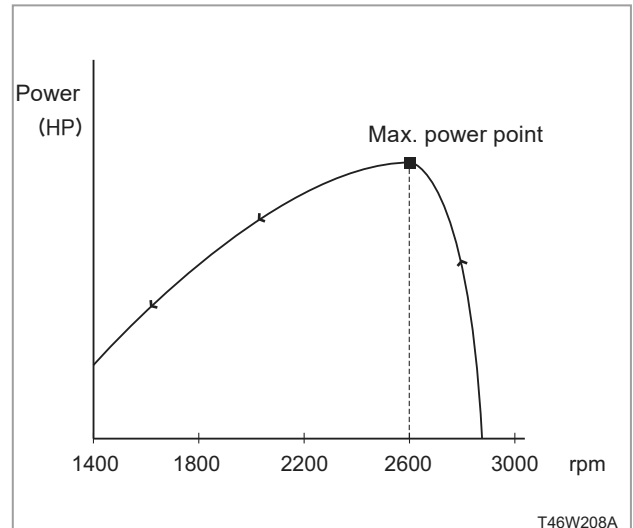

### REMARKS

Work = Force X Distance

Power =  $\frac{\text{Work}}{\text{Time}} = \frac{\text{Force X Distance}}{\text{Time}} = \text{Force X Velocity}$

Power[kW] =  $\frac{F[\text{N}] \times V[\text{m/s}]}{1000} = \frac{F[\text{kgf}] \times V[\text{m/s}]}{102}$

Power[HP] =  $\frac{F[\text{kgf}] \times V[\text{m/s}]}{76}$

1 horse power [HP] = The power necessary to lift up 76kgf of weight with 1m/s of velocity.

1 horse power [PS] = The power necessary to lift up 75kgf of weight with 1m/s of velocity.

(※ kW =  $\frac{102}{76} = \text{HP} = 1.34 \cdot \text{HP}$ )

Power[HP] =  $\frac{F \cdot V}{76} = \frac{T}{R} \cdot \frac{2\pi R \cdot \text{rpm}}{60}$

(Where, T = F · R)

=  $\frac{T \cdot 2\pi \cdot \text{rpm}}{76 \times 60} = \frac{T \cdot \text{rpm}}{76 \times 60} = \frac{T \cdot \text{rpm}}{2\pi} = \frac{T \cdot \text{rpm}}{725.7}$

(Where, T[kgf-m] = Torque  
rpm = Revolution per minute)

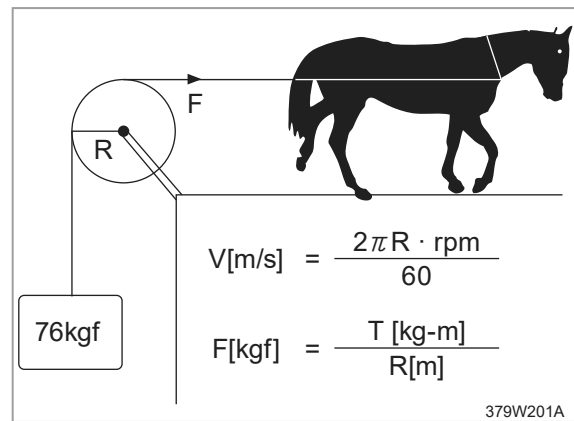

### 2.5.3 S.F.C (SPECIFIC FUEL CONSUMPTION) (FOR REFERENCE ONLY)

The unit used here is "g/kW-hr".

For example, 208g/kW-hr means that 208g of fuel is consumed by 1kW when running the engine for 1 hour.

This can be converted as follows:

Since the fuel consumption at full power in the power curve [4HT14] is 208g/kW-hr, the fuel consumption for 54.9kW(73.6HP) is 208g x 54.9/hr = 11.419kg/hr.

When converting this value to volume value,

11.419 ÷ 0.835 ℓ/hr = 13.68 ℓ/hr

Because: Diesel fuel 1 ℓ = 0.835 kg

However, the actual fuel consumption will be much less than this maximum fuel consumption in accordance with load factor of job. In general, the load factor could be 30~70% of maximum power.

Therefore the actual fuel consumption will also be 30~70% of this maximum fuel consumption.



**2.6 SERVICING SPECIFICATIONS**

**2.6.1 ENGINE BODY**

ITEM		SPECIFICATION	ALLOWABLE LIMIT	
A. Cylinder Head	Cylinder head surface flatness	-	0.05 mm / 100 mm (0.002 in. / 3.94 in.)	
	T.D.C clearance	0.32 ~ 0.7 mm (0.01250 ~ 0.02755 in.)	-	
	Gasket Thickness	Tightened 1.02 mm (0.040 in)	-	
	Compression Pressure (When cranking with starter motor) ※ Variance of compression pressure among cylinders should be 10% or less.	3.24 ~ 3.73 MPa 33 ~ 38 kgf/cm <sup>2</sup> 470 ~ 541 psi	2.55 MPa 26 kgf/cm <sup>2</sup> 370 psi	
B. Valves	Valve Clearance (Cold)	IN.	0.20 mm (0.0079 in.)	-
		EX.	0.20 mm (0.0079 in.)	-
	Valve Seat Angle	IN.	60° (1.047 rad.)	-
		EX.	45° (0.785 rad.)	-
	Valve Face Angle	IN.	60° (1.047 rad.)	-
		EX.	45° (0.785 rad.)	-
	Valve recess	IN.	0.4 ~ 0.8 mm (0.0157 ~ 0.0314 in.)	1.0 mm (0.0393 in.)
		EX.	0.2 ~ 0.6 mm (0.0079 ~ 0.0236 in.)	0.8 mm (0.0315 in.)
	Clearance Between Valve Stem and Valve Guide		0.040 ~ 0.043 mm (0.0016 ~ 0.0017 in.)	0.1 mm (0.0039 in.)
	Valve Stem O.D.		7.960 ~ 7.975 mm (0.31339 ~ 0.31398 in.)	-
Valve Stem I.D.		8.015 ~ 8.030 mm (0.3156 ~ 0.3161 in.)	-	
C. Valve Timing	Intake Valve	Open	0.14 rad (8°) before T.D.C	-
		Close	0.611 rad (35°) after B.D.C	
	Exhaust Valve	Open	0.785 rad (45°) before B.D.C	-
		Close	0.140 rad (8°) after T.D.C	
D. Cylinder	Bore I.D.	87.000 ~ 87.022 mm (3.425 ~ 3.426 in.)	0.15 mm (0.0059 in.)	
E. Valve spring	Free length	46.1 ~ 46.9 mm (1.8150 ~ 1.8465 in.)	45.6 mm (1.7955 in.)	
	Load after assembled / Length after assembled	19.8 kgf / 35.15 mm (43.6 lbs / 1.3839 in.)	16.8 kgf / 35.15 mm (37.0 lbs / 1.3839 in.)	
	Squareness	-	1.0 mm (0.0394 in.)	
F. Rocker Arm	Rocker arm shaft O.D.	18.955 ~ 18.980 mm (0.7463 ~ 0.7472 in.)	-	
	Rocker arm bushing I.D.	19.000 ~ 19.025 mm (0.7480 ~ 0.7490 in.)	-	

SAFETY FIRST

ENGINE

DRIVING & CHASSIS

HYDRAULIC SYSTEM

ELECTRIC SYSTEM

CABIN

INDEX

ITEM		SPECIFICATION	ALLOWABLE LIMIT
G. Tappet	Clearance between tappet and guide	0.020 ~ 0.062 mm (0.00079 ~ 0.00244 in.)	0.07 mm (0.0028 in.)
	Tappet O.D.	23.959 ~ 23.980 mm (0.94327 ~ 0.94410 in.)	-
	Tappet guide I.D.	24.000 ~ 24.021 mm (0.94488 ~ 0.94571 in.)	-
H. Camshaft	Camshaft deflection	0.01 mm (0.0004 in.)	0.05 mm (0.0020 in.)
	Cam height	IN.	33.59 mm (1.3224 in.)
		EX.	33.69 mm (1.3264 in.)
	Journal oil clearance	0.050 ~ 0.091 mm (0.00197 ~ 0.00358 in.)	0.15 mm (0.0059 in.)
	Camshaft journal O.D.	39.934 ~ 39.950 mm (1.57220 ~ 1.57283 in.)	39.88 mm (1.5701 in.)
	Camshaft counter bore I.D.	40.000 ~ 40.025 mm (1.57480 ~ 1.57579 in.)	-
Camshaft gear shaft clearance	0.07 ~ 0.22 mm (0.003 ~ 0.009 in.)	-	
I. Timing Gear	Timing gear backlash	0.04 ~ 0.10 mm (0.0016 ~ 0.0039 in.)	0.14 mm (0.0055 in.)
	Idle gear side clearance	0.050 ~ 0.250 mm (0.00196 ~ 0.00984 in.)	0.5 mm (0.0197 in.)
	Clearance between Idle gear 1 shaft and idle gear 1 bushing	0.025 ~ 0.066 mm (0.00098 ~ 0.00260 in.)	0.1 mm (0.0039 in.)
	Idle gear 1 shaft O.D.	42.959 ~ 42.975 mm (1.69130 ~ 1.69193 in.)	-
	Idle gear 1 bushing I.D.	43.000 ~ 43.025 mm (1.69291 ~ 1.69390 in.)	-
	Clearance between Idle gear 3 shaft and idle gear 3 bushing	0.025 ~ 0.066 mm (0.00098 ~ 0.00260 in.)	0.1 (0.0039 in.)
	Idle gear 3 shaft O.D.	31.959 ~ 31.975 mm (1.25823 ~ 1.25886 in.)	-
	Idle gear 3 bushing I.D.	32.000 ~ 32.025 mm (1.25984 ~ 1.26083 in.)	-
	Clearance between Idle gear 4 shaft and idle gear 4 bushing	0.025 ~ 0.066 mm (0.00098 ~ 0.00260 in.)	0.1 (0.0039 in.)
	Idle gear 4 shaft O.D.	27.967 ~ 27.980 mm (1.10106 ~ 1.10157 in.)	-
Idle gear 4 bushing I.D.	28.005 ~ 28.033 mm (1.10256 ~ 1.10366 in.)	-	

	<b>ITEM</b>	<b>SPECIFICATION</b>	<b>ALLOWABLE LIMIT</b>
J. Piston Ring	Piston pin bore I.D.	30.006 ~ 30.014 mm (1.18134 ~ 1.18165 in.)	-
	Clearance between Oil ring and ring groove	0.020 ~ 0.060 mm (0.00079 ~ 0.00236 in.)	0.15 mm (0.0059 in.)
	Oil ring groove width	3.01 ~ 3.03 mm (0.11850 ~ 0.11929 in.)	-
	Oil ring width	2.97 ~ 2.99 mm (0.11693 ~ 0.11772 in.)	-
	Clearance between 2nd ring and ring groove	0.04 ~ 0.08 mm (0.00157 ~ 0.00315 in.)	0.15 mm (0.0059 in.)
	2nd ring groove width	2.03 ~ 2.05 mm (0.07992 ~ 0.08071 in.)	-
	2nd ring width	1.97 ~ 1.99 mm (0.07756 ~ 0.07834 in.)	-
	Top ring, oil ring end gap	0.25 ~ 0.40 mm (0.00984 ~ 0.01575 in.)	1.25 mm (0.0492 in.)
	2nd ring end gap	0.40 ~ 0.55 mm (0.01575 ~ 0.02165 in.)	1.25 mm (0.0492 in.)
K. Connecting Rod	Connecting rod deflection limit	-	0.05 mm (0.0020 in.)
	Clearance between piston and small end bushing	0.025 ~ 0.045 mm (0.00098 ~ 0.00177 in.)	-
	Piston pin O.D.	29.995 ~ 30.000 mm (1.18090 ~ 1.18110 in.)	-
	Piston pin bushing I.D.	30.025 ~ 30.040 mm (1.18209 ~ 1.18268 in.)	-
L. Crankshaft	Crankshaft deflection limit	-	0.08 mm (0.0031 in.)
	Clearance between Crankshaft and crankshaft bearing 1	0.040 ~ 0.104 mm (0.00157 ~ 0.00400 in.)	0.20 mm (0.0079 in.)
	Crankshaft O.D.	59.921 ~ 59.940 mm (2.35909 ~ 2.35984 in.)	-
	Crankshaft bearing 1 I.D.	59.980 ~ 60.025 mm (2.36142 ~ 2.36319 in.)	-
	Clearance between crank pin and crank pin bearing	0.017 ~ 0.073 mm (0.00067 ~ 0.00287 in.)	0.20 mm (0.0079 in.)
	Crankshaft pin O.D.	51.959 ~ 51.975 mm (2.04563 ~ 2.04626 in.)	-
	Crankshaft pin bearing I.D.	51.992 ~ 52.032 mm (2.04693 ~ 2.04850 in.)	-
	Crankshaft side clearance	0.15 ~ 0.31 mm (0.0059 ~ 0.0122 in.)	0.5 mm (0.020 in.)

SAFETY FIRST

ENGINE

DRIVING & CHASSIS

HYDRAULIC SYSTEM

ELECTRIC SYSTEM

CABIN

INDEX

## 2.6.2 LUBRICATING SYSTEM

ITEM		SPECIFICATION	ALLOWABLE LIMIT	
A. Oil Pump	Engine oil pressure (oil temp. 85 ~ 95 °C)	At idle speed (1,000 rpm)	68.6 kPa or more 0.7 kgf/cm <sup>2</sup> 9.95 psi	-
		At rated speed (2,600 rpm)	245.1 ~ 441.2 kPa 2.5 ~ 4.5 kgf/cm <sup>2</sup> 35.5 ~ 64.0 psi	294.2 kPa 3.0 kgf/cm <sup>2</sup> 42.7 psi
	Clearance between inner rotor and outer rotor		0.10 ~ 0.16 mm (0.0039 ~ 0.0063 in.)	0.2 mm (0.0079 in.)
	Clearance between outer rotor and pump		0.11 ~ 0.19 mm (0.00433 ~ 0.00748 in.)	0.25 mm (0.0098 in.)
	Clearance between inner rotor and cover		0.105 ~ 0.150 mm (0.00413 ~ 0.00591 in.)	0.2 mm (0.00787 in.)

## 2.6.3 COOLING SYSTEM

ITEM		SPECIFICATION	SPECIFICATION	
A. Thermostat	Valve opening temperature at beginning	80.5 ~ 83.5°C (176.9 ~ 182.3°F)	-	
	Opened completely (height: 8 mm)		95°C (203°F)	-
B. Radiator	Radiator hose tightness		No leak at 1.4 kgf/cm <sup>2</sup> (137 kpa, 20 psi)	-
	Radiator cap tightness		10 seconds or more for pressure drop from 0.9 → 0.6 kgf/cm <sup>2</sup> (88 → 59 kpa, 13 → 9 psi)	-
C. Fan cooler	Fan belt tension [deflection at 78 N (8 kgf, 18 lbs) of force]		7 ~ 9 mm (0.28 ~ 0.35 in.)	-

**2.6.4 TIGHTENING TORQUES FOR ENGINE**

ITEM	SIZE X PITCH	TIGHTENING TORQUE					
		Nm		kgf-m		lb-ft	
Cylinder head bolt	M11×1.25	39.22+90°+70°		4+90°+70°		28.8+90°+70°	
Head cover bolt	M6×1.0	8.8	11.8	0.9	1.2	6.5	8.7
Main bearing bolt	M12×1.25	90.2	93.2	9.2	9.5	66.5	68.7
Ladder frame bolt	M10×1.25	47.1	52	4.8	5.3	34.7	38.3
Piston cooling jet bolt	M12×1.25	29.4	34.3	3	3.5	21.7	25.3
*Flywheel bolt	M12×1.25	98.1	107.9	10	11	72.3	79.6
*Connecting rod bolt	M8×1.0	44.1	49	4.5	5	32.5	36.2
Rocker arm support bolt	M10×1.25	60.8	70.6	6.2	7.2	44.8	52.1
Injector clamp bolt	M8×1.25	27.5	31.4	2.8	3.2	20.3	23.1
Hi-pressure pipe nut (pump side)	M14×1.5	24.5	29.4	2.5	3	18.1	21.7
Hi-pressure pipe nut (rail side)	M14×1.5	27.5	31.4	2.8	3.2	20.3	23.1
Crank shaft bolt	M16×1.5	320.7	343.2	32.7	35	236.5	253.2
Glow plug	M10×1.25	19.6	24.5	2	2.5	14.5	18.1
Eye-bolt (turbo side)	M10×1.25	27.5	31.4	2.8	3.2	20.3	23.1
Eye-bolt (nut side)	M12×1.5	32.4	37.3	3.3	3.8	23.9	27.5
Coolant temp sensor	PT3/8	34.3	44.1	3.5	4.5	25.3	32.5
Oil pressure switch	PT1/8	14.7	19.6	1.5	2	10.8	14.5

**⚠ CAUTION**

- For \* marked screw, bolts and nuts on the table, apply engine oil to their threads and seats before tightening.
- The letter "M" in Size × Pitch means that the screw, bolt or nut dimension stands for metric. The size is the nominal outside diameter in mm of the threads. The pitch is the nominal distance in mm between two threads.

**ⓘ IMPOARTANT**

- Tightening torque for cylinder head bolts  
Tightening order (using the angle controlled tightening method)  
1st step: Tighten the bolts to 4.0 kgf-m (39.2 Nm, 28.8 lb-ft)  
2nd step: Rotate the bolts additional 90°  
3rd step: Rotate the bolts additional 70°
- For more details, refer to 7.3.4 "Cylinder head removal."

### 3. OPERATING PRINCIPLE

#### 3.1 CRDI (COMMON RAIL DIRECT INJECTION) SYSTEM

The CRDI (Common Rail Direct Injection) engine is a high performance engine, featuring superior emission, acceleration, vibration and noise functions. The old version of diesel engines simply delivers fuel into the combustion chamber through its mechanical structure. On the other hand, in the CRDI engine, fuel sent from the fuel tank is pressurized to the necessary level by the high-pressure fuel pump and it is stored in the common rail for use. Then, the ECU controls the injector according to the detected engine RPM, load and other factors to inject fuel into the combustion chamber in the optimum injection condition. It is hard to meet the optimum injection condition and achieve precise control on injection timing in a normal diesel engine of the cam injection type.

On the other hand, the common rail type engine stores highly pressurized fuel in the common rail to inject the necessary amount of fuel at the correct timing for optimal combustion, resulting in emission reduction and engine power increase.

The atomization level, injection timing and injection pressure of fuel have a huge impact on combustion performance.

Therefore, in the CRDI engine, as the injector injects highly pressurized fuel (under 1,800 bars) into the combustion chamber according to control from the ECU, it injects fuel as fast as possible to make fuel almost gaseous condition (atomization) at a high pressure.

Also, as it is still possible to inject fuel at a high pressure while the engine is running at a low speed with high load, up to torque increase and power improvement can be achieved at a low speed.

The CRDI engine mainly consists of the high-pressure pump, pressure control valve, common rail, pressure sensor, injector, ECU and other sensors and actuators.

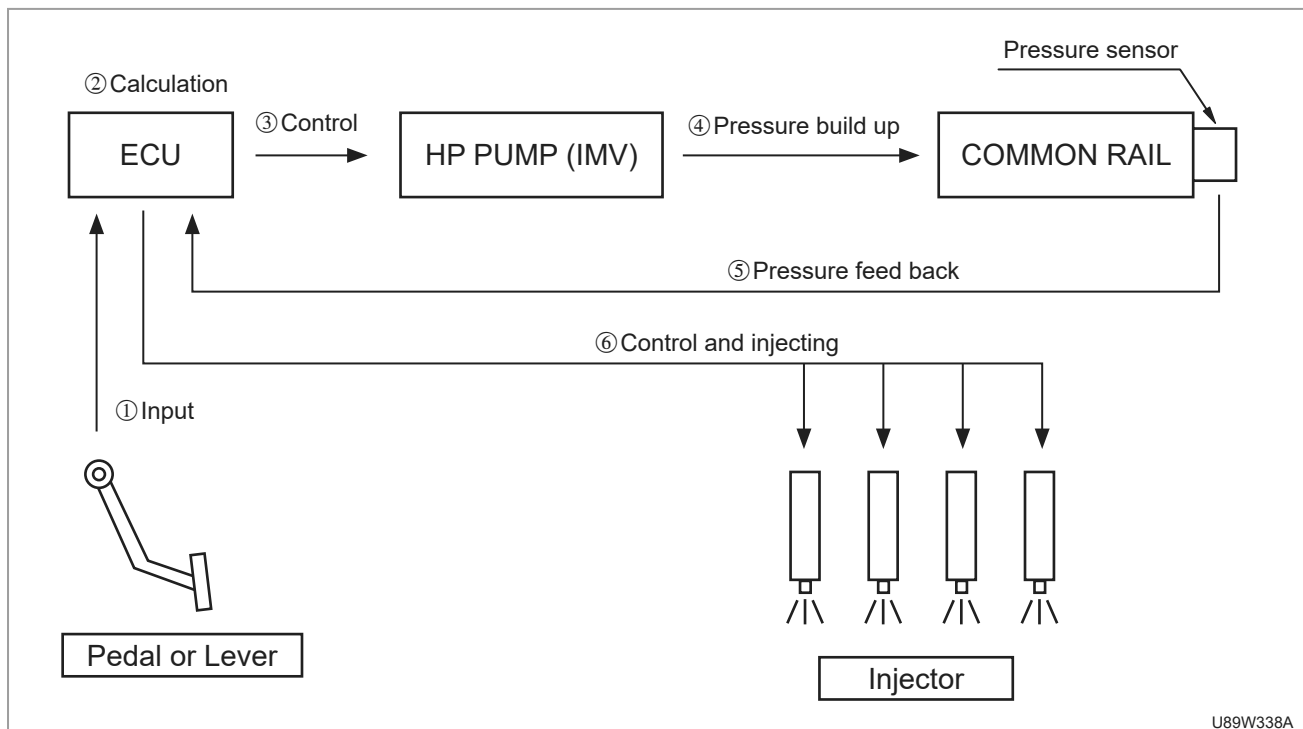

U89W338A

- The position information of the pedal intended by the driver (the amount of movement of the pedal or hand lever) is sent to the ECU as a signal.
- The ECU determines the required RPM according to this position information and calculates the correct injection pressure and injection timing (fuel injection amount) to achieve this target RPM.
- It controls the IMV of the HP pump to increase pressure in the common rail.
- It supplies high-pressure fuel to the common rail to increase the rail pressure to the pressure level demanded by the ECU.
- The pressure sensor in the common rail sends pressure information to the ECU to confirm whether the actual pressure matches the demanded pressure.
- When pressure in the rail is sufficiently built, the ECU controls the injector to inject fuel for a proper amount of time.
- \* The fundamental injection map is set by positions of the pedal or hand lever, and the rail pressure and injection timing are corrected, considering other several external factors, including the intake air temperature, coolant temperature and barometric pressure.

**STRUCTURE & FUEL LINE**

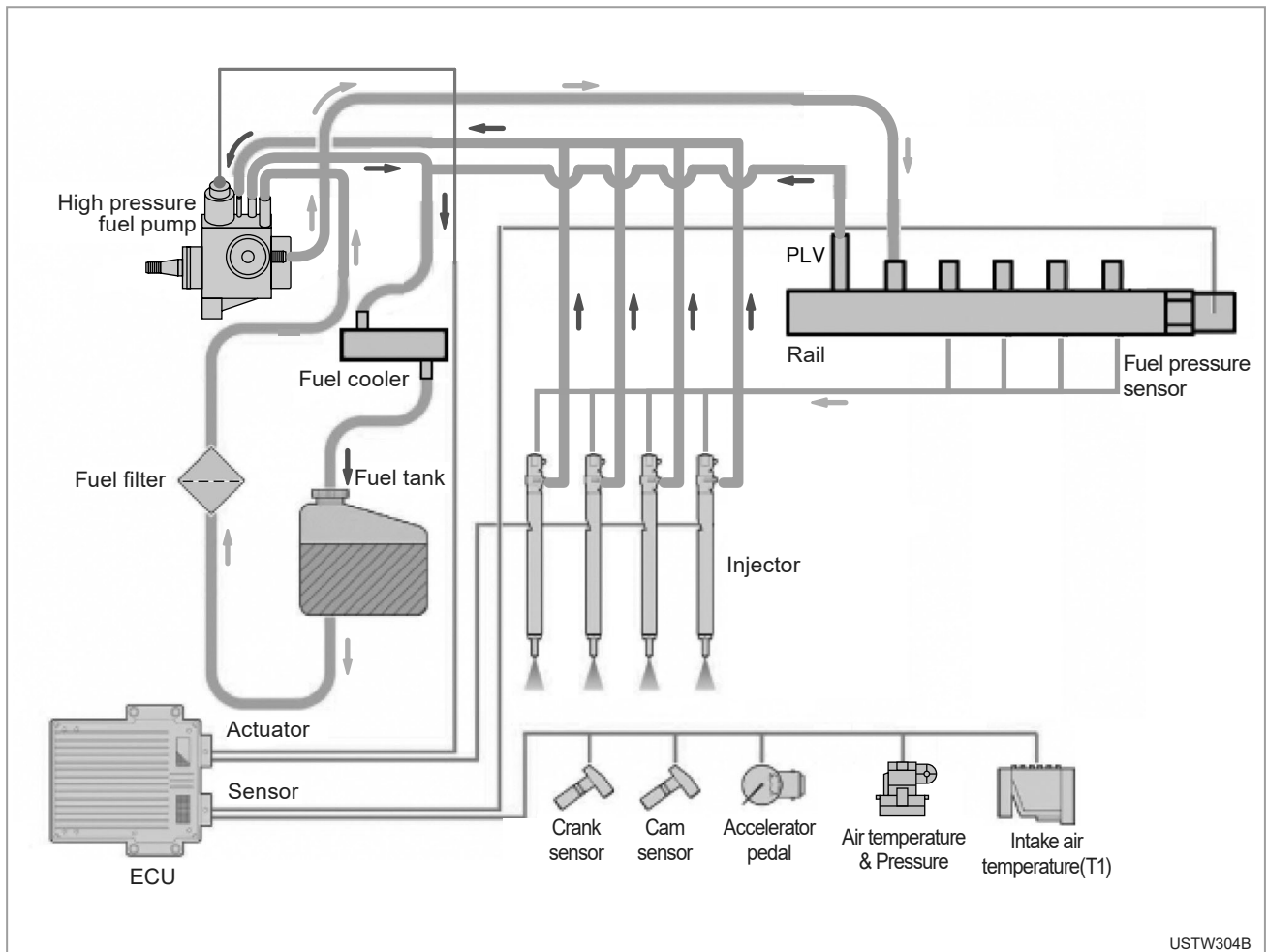

USTW304B

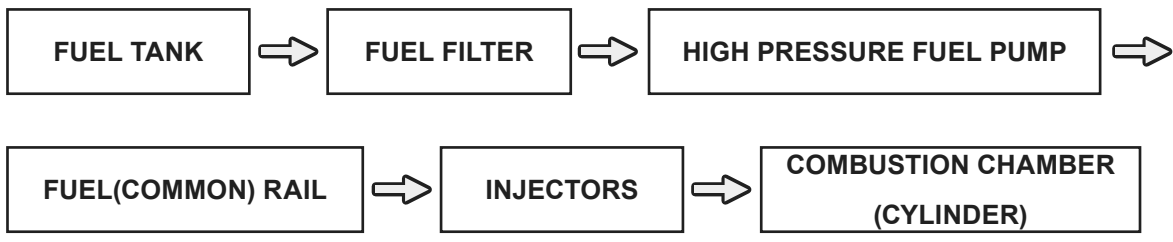

**COMPONENTS**

- HIGH PRESSURE FUEL PUMP : Supplies highly pressurized fuel to fuel rail
- FUEL(COMMON) RAIL : Stores fuel pressurized down to 1,800 bars before injection
- INJECTOR : Performs pilot and post injections into each cylinder
- ECU(Electronic Control Unit) : Controls injection condition, such as injection timing, injection amount and injection pressure
- SENSOR & ACTUATOR : Detects fuel temperature, fuel pressure, intake air temperature, coolant temperature, engine RPM, etc.

### 3.1.1 ECU(ELECTRONIC CONTROL UNIT)

#### OVERVIEW

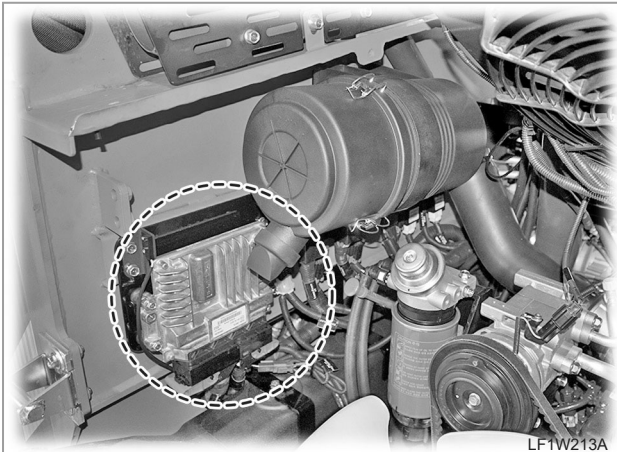

The ECU (Electronic Control Unit) is the most important information processor in the engine as it analyzes information sent from various sensors and takes an appropriate action for optimum engine performance.

The ECU is integrated with I/O devices, ROM and RAM. Various sensors, including the coolant temperature sensor, intake air temperature sensor, crank angle sensor, cam position sensor, throttle position sensor, air mass flow sensor and rail pressure sensor, check the engine condition and send the corresponding signals to the ECU.

Then, the ECU receives signals from these sensors, analyzes them and changes voltage to the permissible level based on these information to activate various actuators.

The ECU stores certain map values as standard. Its micro-processor calculates the injection duration and timing according to the piston speed and crankshaft angle to control the engine power and exhaust gas.

Also, the output signal from the ECU micro-processor is used to drive the IMV in order to control the pressure in the fuel rail suitable for the engine load condition for optimum performance without any power loss.

The engine ECU calculates the command from the driver (accelerator pedal position) and controls overall operating performance of the engine and vehicle instantly. The engine speed is detected by the crankshaft speed (position) sensor while the injection order is determined by the camshaft speed (position) sensor.

The MAF (Mass Air Flow) sensor detects the amount of

intake air and sends this information to the engine ECU which then determines the instant air volume change to control the air-fuel ratio for reduction of exhaust gas (EGR valve control). Also, the ECU receives signals from the coolant temperature sensor, air temperature sensor and booster pressure sensor and uses them for calibration to manage setting values, various variables and operating conditions for main injection and pilot injection.

#### FUNCTION

##### ► ENGINE CONTROL

##### 1. Control for each operating phase

The ECU needs to calculate the proper fuel injection amount at each phase for optimum combustion. In this process, it takes numerous variables into consideration.

##### 2. Fuel injection amount control for engine start

Fuel is injected from the moment that the ignition switch is turned to the START position until the permissible lower speed limit is achieved. The fuel injection amount is calculated by the specified function based on various temperature information and engine cranking speed.

##### 3. Driving mode control

The fuel injection amount is calculated based on the position of the accelerator pedal and engine RPM and the ECU uses the drive map to obtain optimum engine power according to the driver's intention (accelerator pedal position).



## ► FUEL SYSTEM CONTROL

### 1. Fuel pressure control

- It determines the fuel rail pressure according to the engine operating condition and adjusts the IMV accordingly to achieve necessary rail pressure.
- Pressure in the fuel rail is determined based on the engine RPM and engine load.
- The fuel pressure is calibrated based on the barometric pressure, coolant temperature and intake air temperature. When starting the engine in cold weather or at a high altitude, the added ignition time is additionally considered for calibration of the fuel pressure. When starting the engine, additional fuel injection is needed so pressure is consumed for this moment. Therefore, the fuel pressure is calibrated based on the temperature of the injected fuel or coolant.

### 2. Fuel injection control

- In the fuel injection control process, the ECU determines the characteristics of the current pulses to be sent to the injectors. It converts the fuel injection duration, injection amount and injection timing into values which can be recognized by the injector driver.
- The pulse required for the main injection is determined based on the engine RPM and pilot injection amount.
  - The first calibration is determined by the temperature of intake air and coolant. The fuel injection timing is adjusted according to the operating temperature of the engine. When the engine temperature is high, the fuel injection timing is retarded to reduce high combustion temperature and hazardous emissions (NOx). When the engine temperature is low, the fuel injection timing is advanced to achieve optimum combustion performance.

The second calibration is determined by the barometric pressure. This information is used to advance the injection timing in order to respond to the barometric pressure changes with altitudes.

The third calibration is determined by the coolant temperature and time after the engine is started. When the engine is started, the fuel injection timing is advanced in the engine warmup period (30 seconds) to increase the amount of fuel injected and eliminate any possible misfire or unstable combustion.

The fourth calibration is determined by the pressure error. This calibration is to retard the injection timing to prevent diesel knocking when the fuel rail pressure is higher than the necessary level.

The fifth calibration is determined by the EGR ratio. When the EGR ratio increases, the fuel injection timing is retarded to compensate the combustion (cylinder) temperature drop.

The injection timing should be adjusted according to each factor to achieve combustion near at the TDC when the engine is started. The ECU is mapped to obtain optimal injection timing.

- The pilot injection timing is determined based on the engine RPM and overall fuel flow.
  - The first calibration is determined by the temperature of intake air and coolant. This calibration is to set the pilot timing according to the operating temperature of the engine.
  - The second calibration is determined by the barometric pressure. This calibration is to adjust the timing according to the barometric pressure changes with altitudes. The pilot injection timing is determined by the engine RPM and coolant temperature when the engine is started.

### 3. MDP(Minimum Dirve Pulse) LEARNING CONTROL

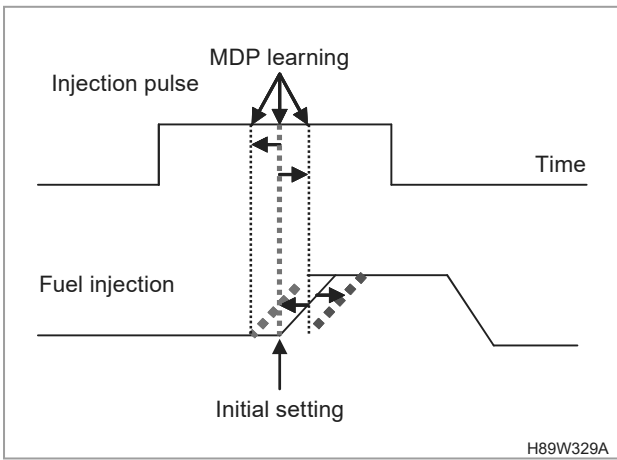

The MDP is the pulse value when the injector starts injecting fuel, and it is actually the period that power is supplied until the needle in the injector moves to the tip. The MDP is controlled to correct the pilot injection timing for aged injectors with relatively low precision. As shown in the figure, fuel injection is initiated at the learned MDP point based on the initial setting. Therefore, the fuel injection timing is retarded or advanced depending on the condition of the nozzle.

The MDP refers to the minimum pulse where power is supplied for fuel injection. When the MDP value is learned precisely, it is possible to control the precise amount of fuel injected by each injector. The knock sensor detects vibration generated from the engine after a small amount of fuel is injected by the injectors. The the MDP is learned by calculating the period from fuel injection to vibration detected from the engine. The MDP is to correct the injection timing for aged injectors in order to reduce engine vibration and emissions and prevent power reduction.

### 4. Fuel control

- The ECU controls the amount of fuel injected to the cylinder for the main injection process.
- The fuel demand amount is determined based on the driver's demand, i.e. displacement of the hand throttle lever or accelerator pedal.
- It controls the idle speed.
- It limits the fuel amount based on the engine speed and intake air amount.
- It controls the amount of fuel injected into the cylinder during the pilot injection process

### ► ACTUATOR CONTROL [INJECTOR AND EGR VALVE]

- It receives signals from various sensors to control the actuator for optimum combustion.

**OPERATION**

► **INPUT/OUTPUT OF ECU ENGINE CONTROL SYSTEM**

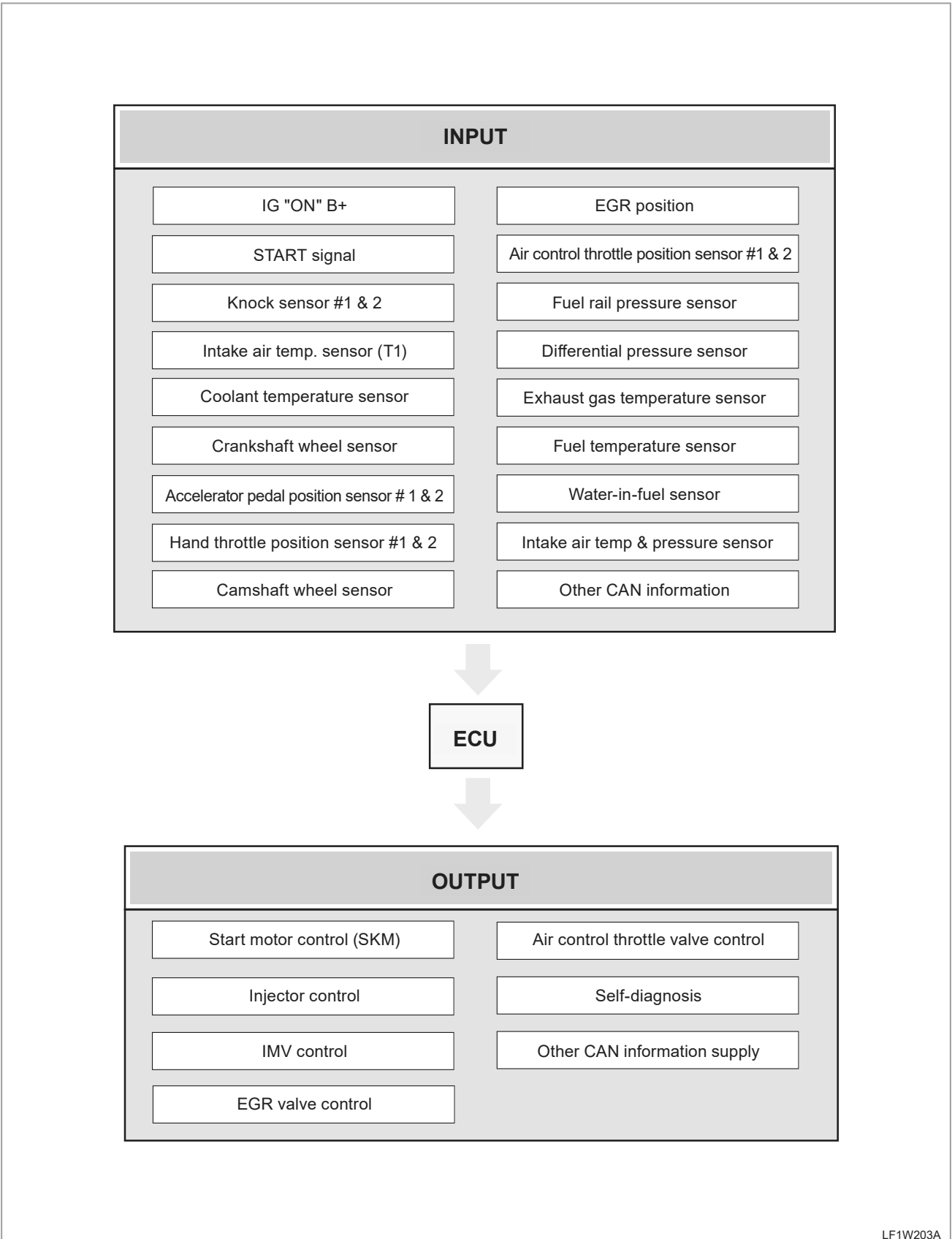

LF1W203A

► INPUT/OUTPUT OF FUEL SUPPLY SYSTEM

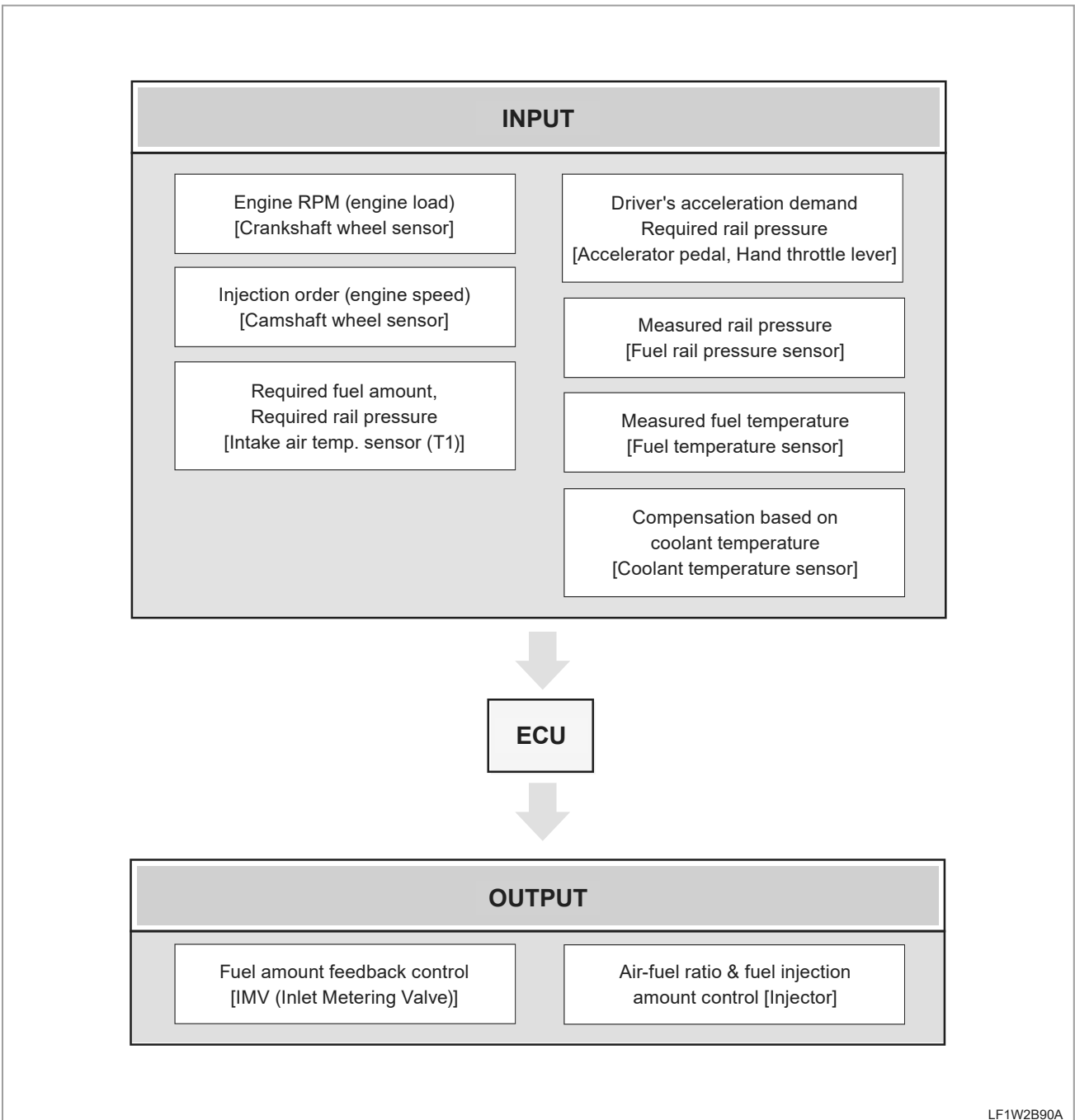

LF1W2B90A

SAFETY FIRST

ENGINE

DRIVING & CHASSIS

HYDRAULIC SYSTEM

ELECTRIC SYSTEM

CABIN

INDEX

► INPUT/OUTPUT OF INTAKE SYSTEM

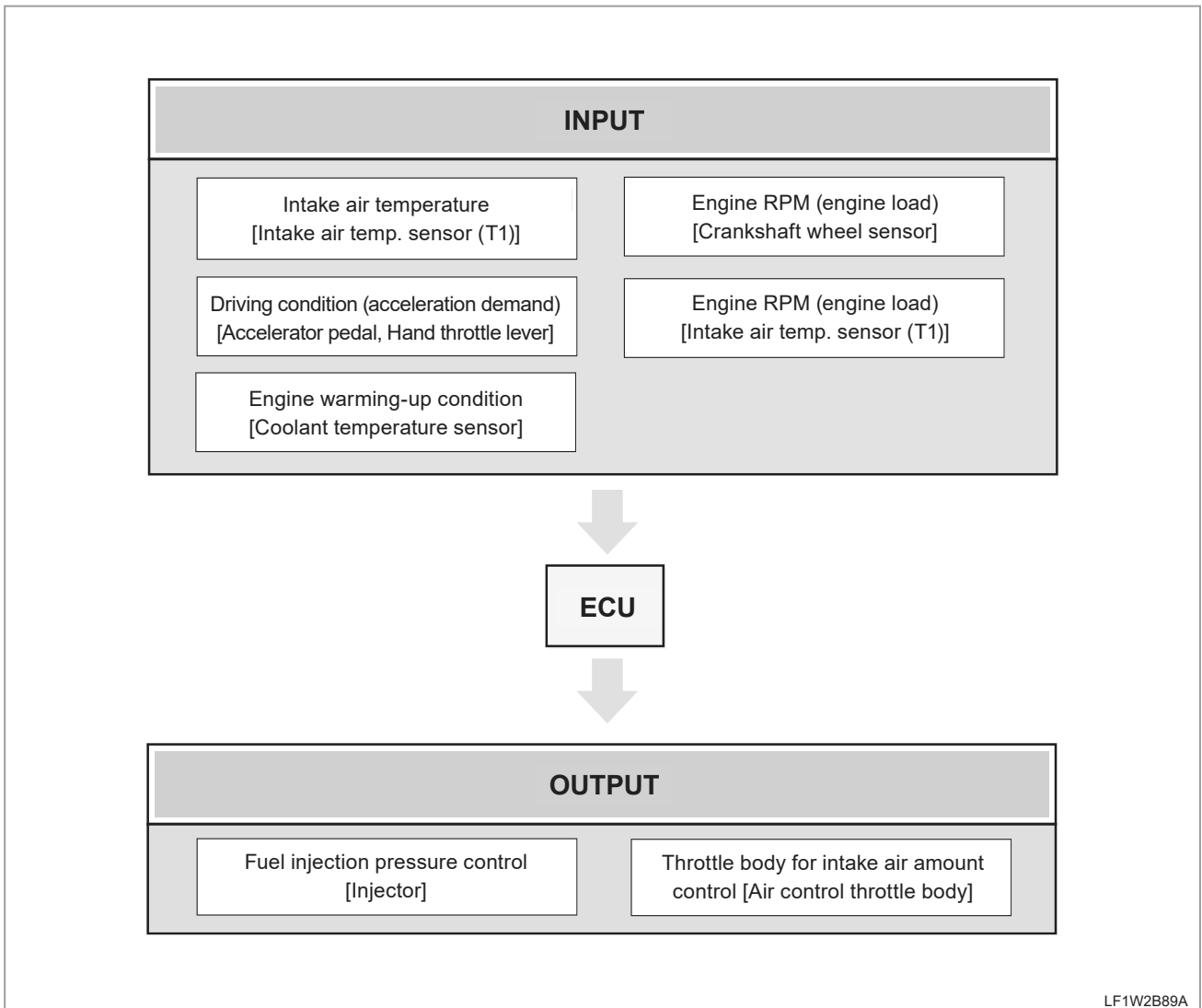

► INPUT/OUTPUT OF EGR VALVE (EXHAUST GAS CONTROL)

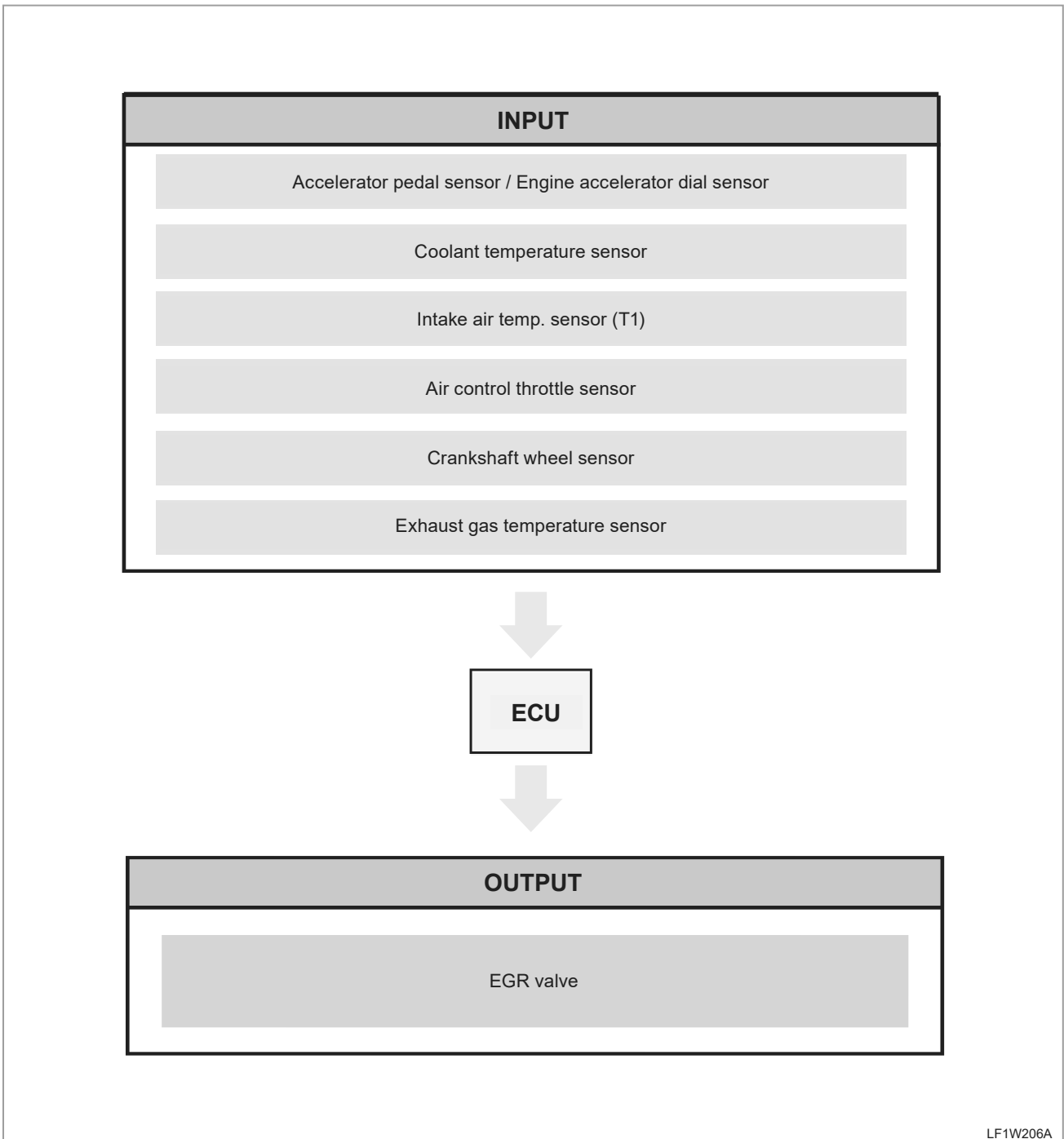

LF1W206A

SAFETY FIRST

ENGINE

DRIVING & CHASSIS

HYDRAULIC SYSTEM

ELECTRIC SYSTEM

CABIN

INDEX

► INPUT/OUTPUT OF CCRT CONTROL

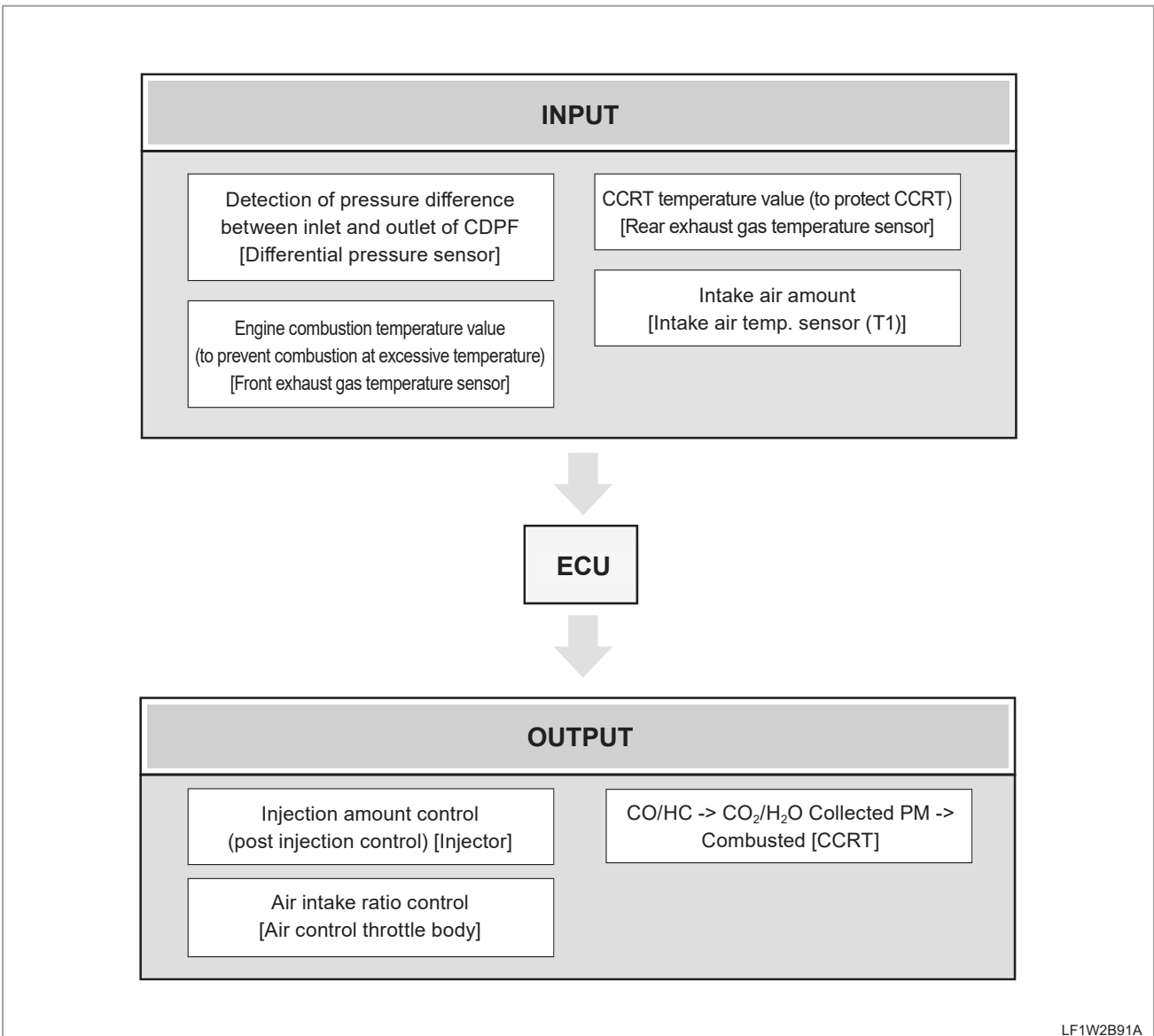

- Front exhaust gas temperature sensor: it is installed to the exhaust manifold to determine whether the DOC can burn (oxidize) injected fuel during the post-injection process.
- Rear exhaust gas temperature sensor: it is installed to the inlet of the DPF to monitor whether the temperature of exhaust gas is maintained at 600°C.
  - Excessive temperature (over 600°C), leading to reduction of CCRT life → Decrease in fuel injection amount in post injection process
  - Insufficient temperature (below 600°C), leading to low efficiency of CCRT regeneration → Increase in fuel injection amount in post injection process
- Differential pressure sensor: it detects the pressure difference between the inlet and outlet of the CCRT to calculate the PM amount.
- Air control throttle valve: it reduces the intake air amount to increase the exhaust gas temperature when the CCRT is activated with the engine idling.

► INPUT/OUTPUT OF PLUG RELAY DRIVER

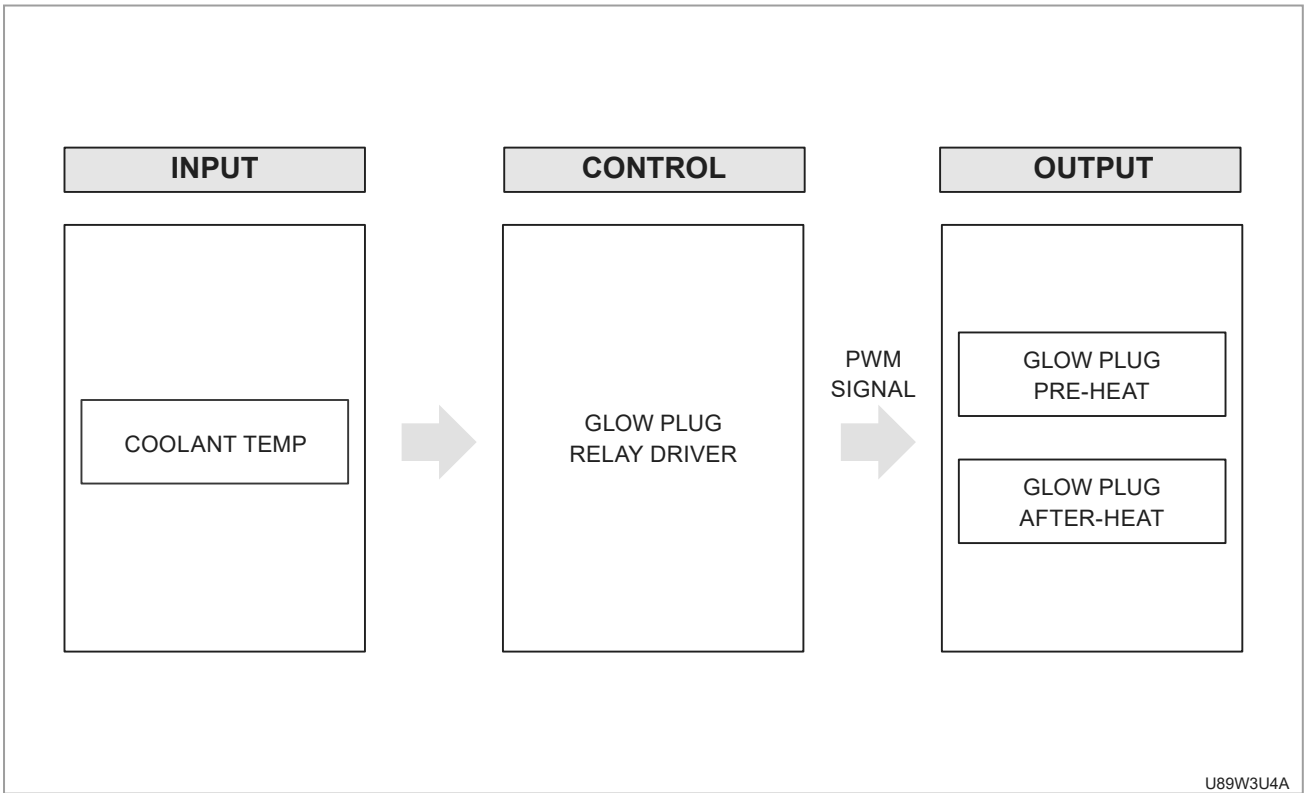



3.1.2 HIGH PRESSURE FUEL PUMP (FOR INJECTION)

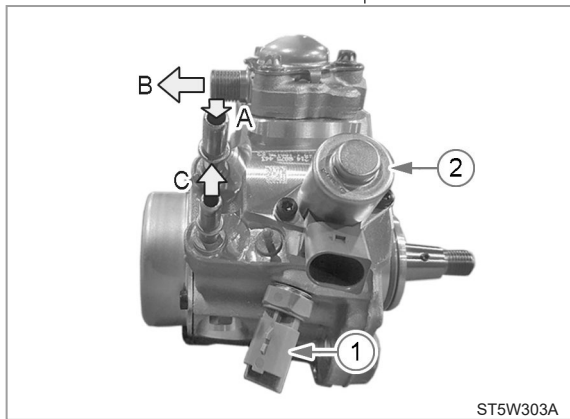
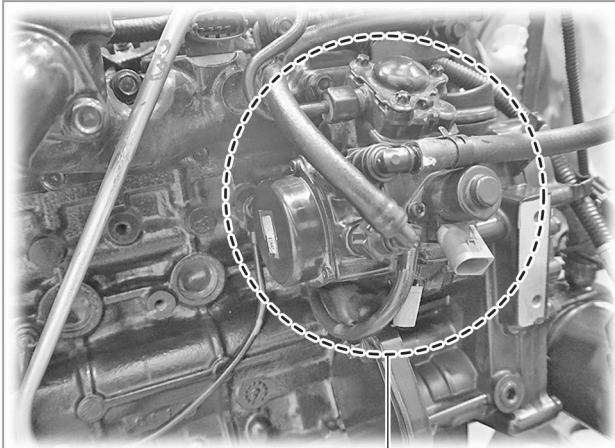

- |                             |                                 |
|-----------------------------|---------------------------------|
| (1) Fuel temperature sensor | (A) From fuel filter (entrance) |
| (2) IMV                     | (B) To fuel rail (exit)         |
|                             | (C) To fuel cooler (return)     |

The high-pressure fuel pump consists of the low-pressure pump (vane pump) which sucks fuel from the fuel tank, high-pressure pump which supplies fuel at a high pressure to the common rail, and IMV (Inlet Metering Valve) which controls the amount of fuel supplied to the high-pressure pump.

The high-pressure fuel pump is connected to and run by the idle gear which is driven by the crankshaft. It is also equipped with the pressure control valve and fuel temperature sensor, apart from the components mentioned above. The pressure control valve opens the oil passage to decrease pressure in the pump when pressure in the common rail rises excessively.

Also, the fuel temperature sensor detects the temperature at the inlet of the high-pressure fuel pump and sends this information to the ECU. Since excessively hot fuel can damage the high-pressure fuel pump, the ECU limits the amount of injected fuel to prevent the engine RPM from rising over a certain level when the fuel temperature rises over the specified value.

This high-pressure fuel pump is the high-pressure pump for the Delphi DFP 4.6.18 TP common rail and features compact and lightweight design.

REMARKS

ADJUSTMENT OF HIGH-PRESSURE PUMP TIMING

- The conventional fuel injection pump pressurized and distributed fuel to each injector. In this case, the pump timing should be set as fuel is injected to the necessary position in a cycle. However, the high-pressure pump of the common-rail engine is not used for fuel injection, so it is not necessary to set its timing for the engine. However, it should be set and adjusted to synchronize the pressure drop by each injection with the peak pressure occurred by the pump in order to enhance pressure control performance. This phase setting enhances pressure stability and reduces fuel flow difference between the cylinders.

## 3.1.3 FUEL RAIL(COMMON RAIL)

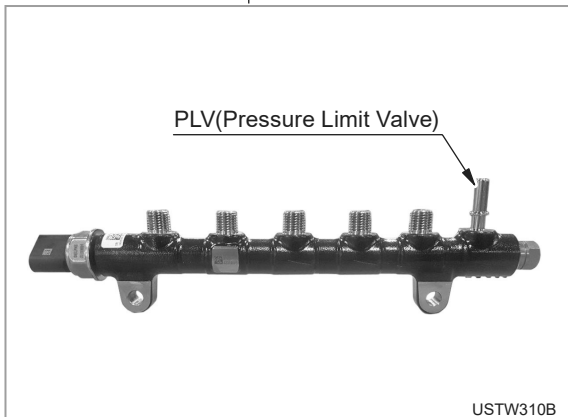
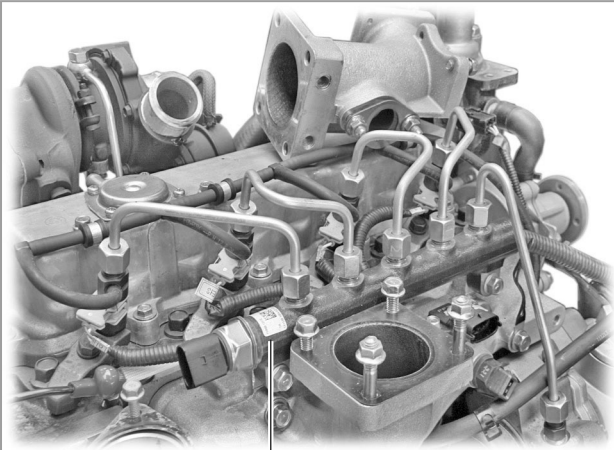

U89W326A

- The Delphi DFR 4.18 PLV fuel rail stores fuel which is pressurized and sent by the high-pressure fuel pump. This device is controlled by the ECU to help fuel rail pressurized fuel to be injected to the engine combustion chamber at a high pressure through all injectors in order to increase engine efficiency and decrease noise and emission.
- Over pressure protection is ensured by the PLV and it will mechanically maintain the rail pressure with a range 500 ~ 1,000 bar (depending on system size) for system safety reason in the event of an overpressure.

## 3.1.4 INJECTOR [C3I]

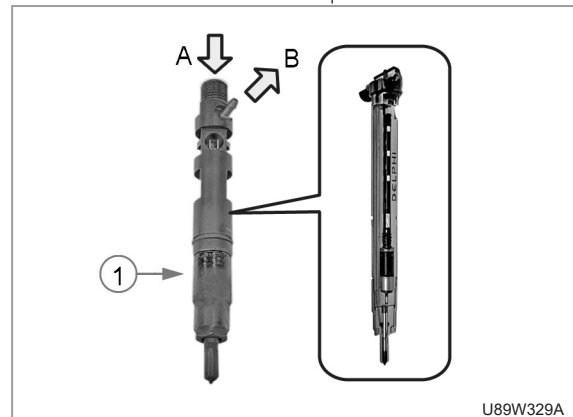
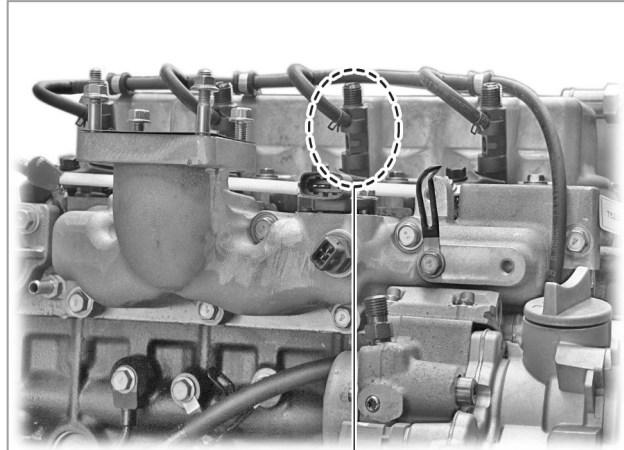

U89W328A

- (1) Injector assembly
- (A) Supplied fuel (from high-pressure pipe)
- (B) Surplus fuel (to overflow pipe)

The Delphi DFI 2.20S injector injects fuel into the combustion chamber according to the signal from the ECU.

The injector is supplied with fuel from the high-pressure fuel pump through the high-pressure pipe and fuel rail. This fuel under high pressure is directly injected into the combustion chamber (on the top of the piston) through the multi-hole injector nozzle by activation of the solenoid valve of the nozzle (through a control signal from the engine ECU). The remainder of fuel after injection (back-leak fuel) is returned to the high-pressure pump through the fuel return line for reuse. Some of fuel supplied to the high-pressure pump is used as lubricant for the pump while fuel returned through the IMV (Inlet Metering Valve) flows back to the fuel tank through the return line.

**INTERNAL VIEW**

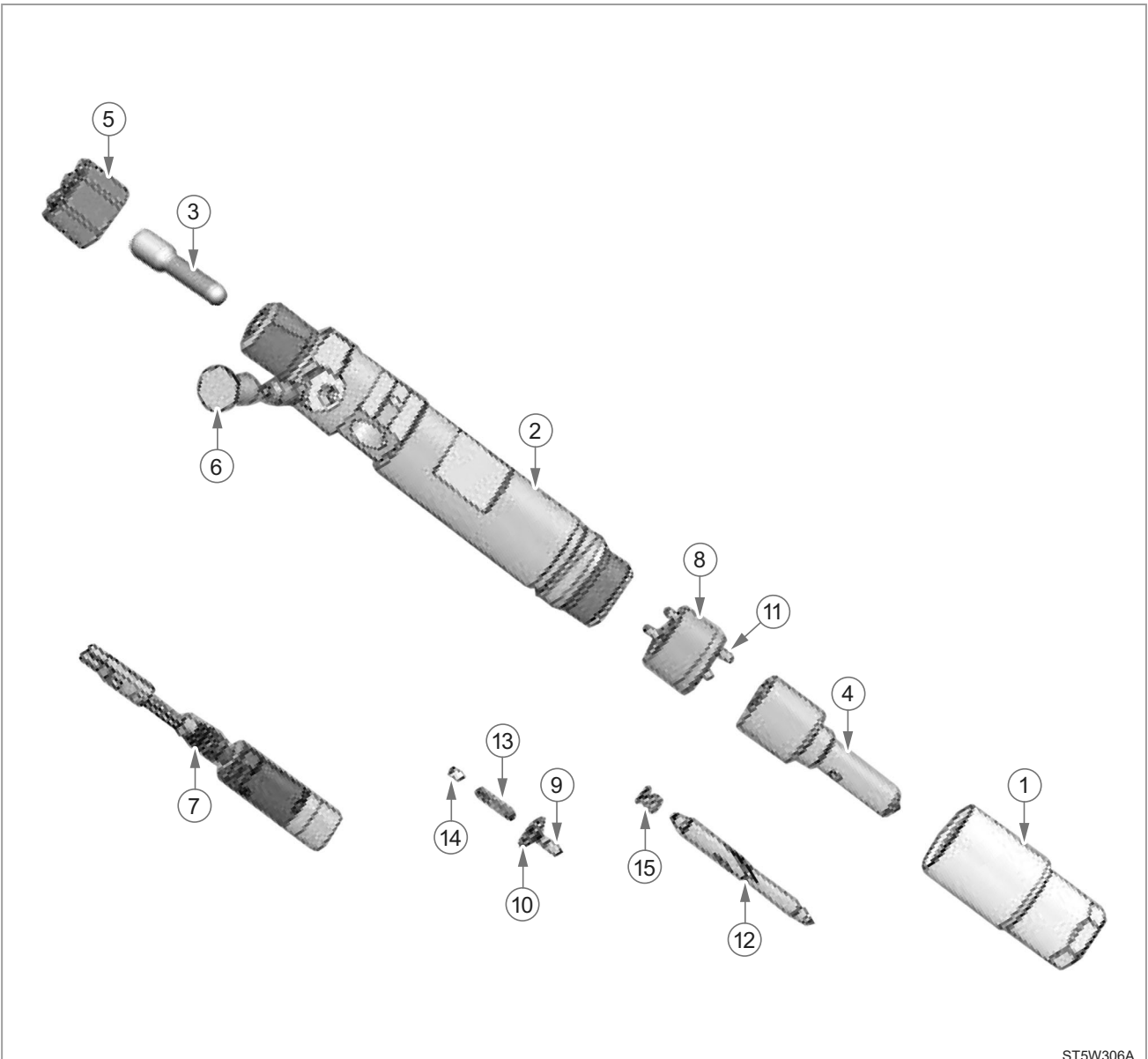

- |                          |                            |                            |
|--------------------------|----------------------------|----------------------------|
| (1) Cap nut              | (6) Back-leak cap          | (11) Dowel pin             |
| (2) Nozzle holder body   | (7) Actuator bobbin        | (12) Needle (nozzle valve) |
| (3) Laser drilled filter | (8) Control valve body     | (13) Actuator spring       |
| (4) Nozzle body          | (9) Control valve step     | (14) Adjust pin            |
| (5) Blocking cap         | (10) Control valve amateur | (15) Injector spring       |

**OPERATING PRINCIPLE**

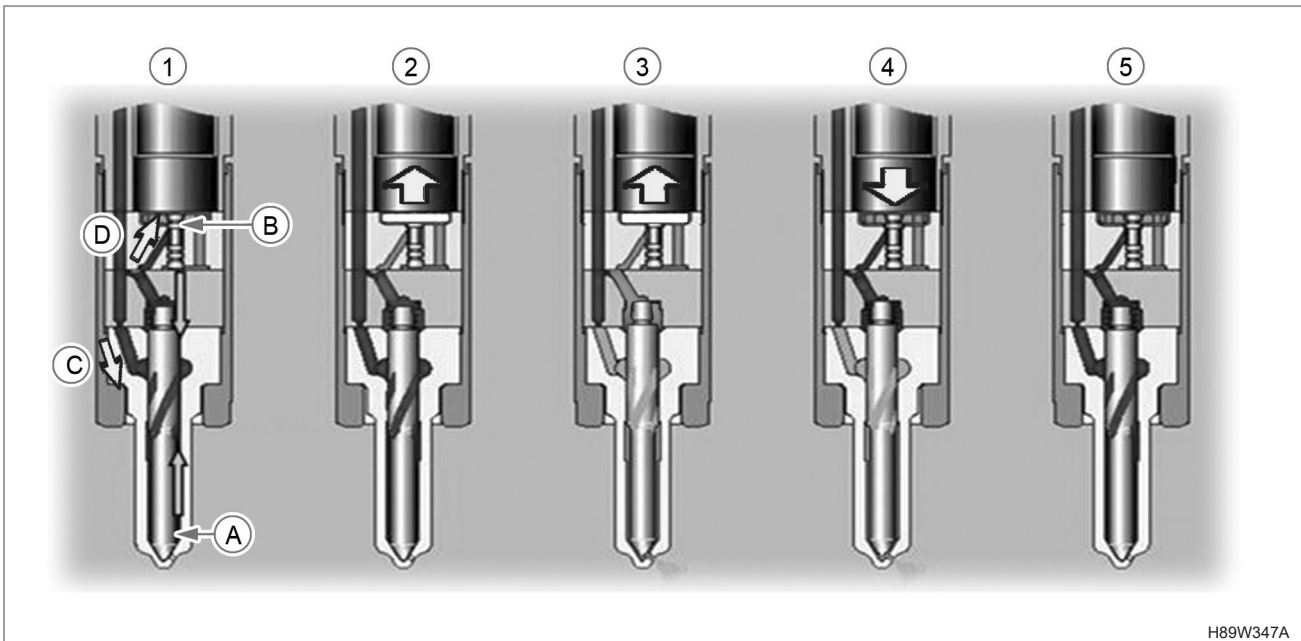

H89W347A

(A) Needle (nozzle valve)

(B) Control valve

1	2	3	4	5
Valve closed	Valve open	Valve open	Valve closed	Valve closed
Nozzle closed	Nozzle closed	Nozzle open	Nozzle open	Nozzle closed
No injection	No injection	Starting injection	Completing injection	No injection

Basically, when the ignition switch is turned to the ON position, the solenoid actuator is energized and the solenoid is compressed, opening the control valve which is connected to the solenoid actuator. Then, fuel at a high pressure is continuously drawn into the combustion chamber through the injector and fuel rail.

- (1) When the control valve (B) is closed in the initial state, the pressure of fuel (C) drawn into the combustion chamber and pressure of fuel (D) drawn into the valve are the same, keeping the nozzle closed.
- (2) When the control valve is opened to start the engine, fuel drawn into the valve is drained to the control valve (B) so pressure of fuel drawn into the combustion chamber increases further.
- (3) As pressure on the valve side becomes lower than pressure in the combustion chamber, the needle (nozzle valve) is pushed up by pressure in the combustion chamber, opening the nozzle tip to initiate fuel injection.
- (4) When the ignition switch is turned to the OFF position, the valve is closed by force of the spring so pressure of fuel drawn to the valve rises gradually.
- (5) The control valve is completely closed and the needle (nozzle valve) is lowered due to increase in pressure of fuel on the valve side. When the needle reaches the bottom, pressure of fuel in the control valve and pressure of fuel in the combustion chamber become equal, completing the fuel injection operation.

After fuel is compressed under up to 1,800 bars by the fuel system of the CRDI (Common Rail Direct Injection) engine and is sent to the injector, the electrically controlled solenoid runs the valve to ensure the correct amount of fuel to be injected according to calculation by the ECU.

**INJECTION**

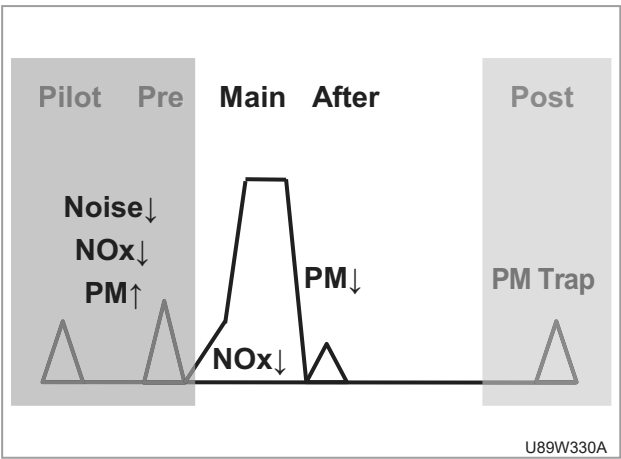

Also, fuel injection is performed in several steps, such as pilot, pre-, main, after- and post-injections, to generate explosive power in steps in order to decrease combustion noise at a low speed dramatically.

► **PILOT INJECTION**

A very small amount of fuel is injected before main injection to facilitate combustion in the combustion chamber. This injection enables pressure in the combustion chamber to rise smoothly during combustion process to decrease NOx(Nitrogen Oxide) engine noise and vibration.

The default amount of fuel injected in the pilot injection process is adjusted according to the coolant temperature and intake air pressure.

► **MAIN INJECTION**

A very small amount of fuel is injected before main injection to facilitate combustion in the combustion chamber. This injection enables pressure in the combustion chamber to rise smoothly during combustion process to decrease NOx(Nitrogen Oxide) engine noise and vibration.

The default amount of fuel injected in the pilot injection process is adjusted according to the coolant temperature and intake air pressure.

► **POST INJECTION**

This injection is performed after the main injection and does not produce actual power. This injection is to reduce PMs and smoke (fuel activation) by injecting fuel into unburned gas after the main injection.

**CAUTION**

- As the injector is very sensitive to cleanness, make sure to seal any disconnected hose or pipe with the cap to prevent introduction of foreign materials.
- When removing the injector, make sure to replace the copper washer on its bottom with a new one.
- Tighten the mounting bolt of the injector mounting clamp to the specified torque.
- Be careful not to drop the injector. It is very sensitive to shock.

**CHARACTERISTICS**



The injector of the common rail system is a highly precise part. The characteristics of injectors can vary by minute differences from their machining. Therefore, it is necessary to calibrate the fuel injection amount for each injector according to their initial characteristics.

The initial characteristics of injectors are coded as C3I. The ECU calibrates current applied to the injector according to this value, C3I.

Also, the injector is controlled according to the fuel feed curve which is set according to various fuel-related parameters for precise characterization of injection in order to reduce deviation.

► INJECTOR CHARACTERISTIC CURVE

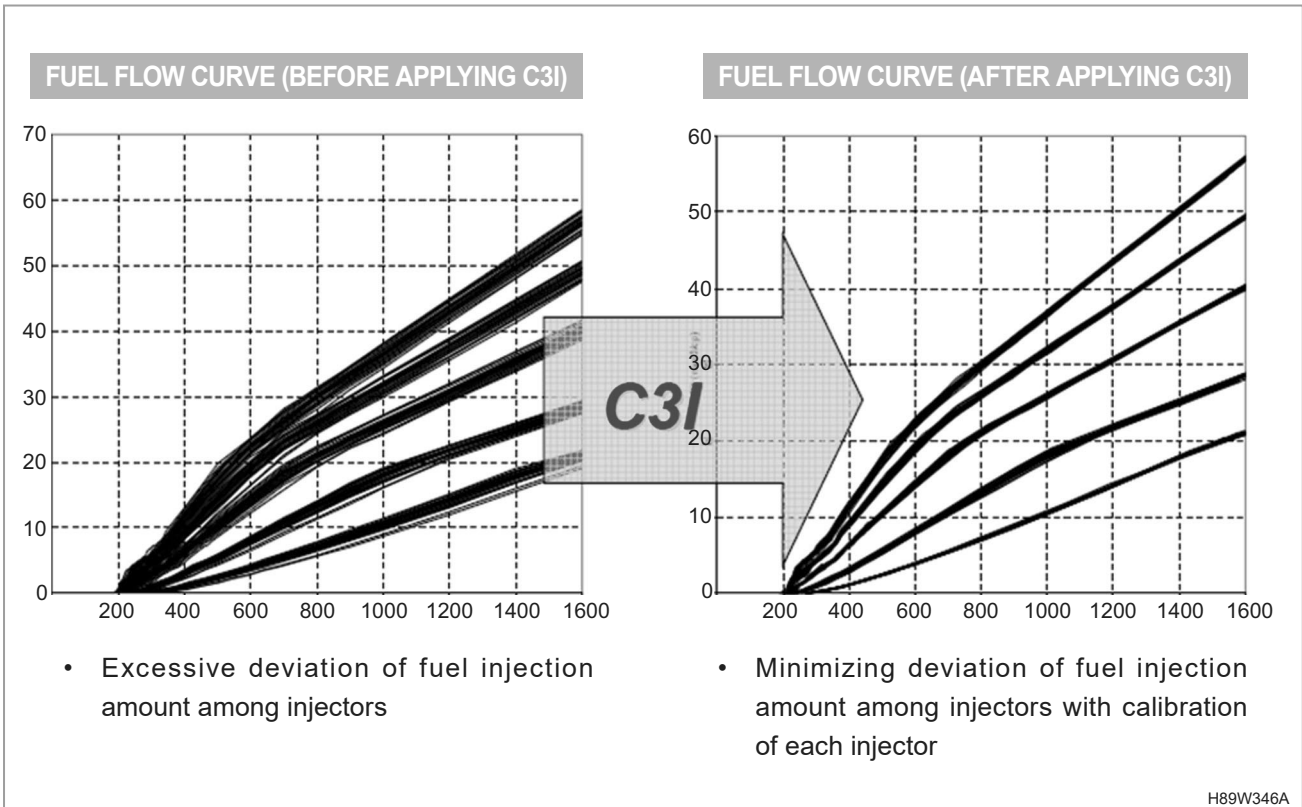

3.2 BODY AND POWER TRAIN SYSTEM

3.2.1 CYLINDER HEAD

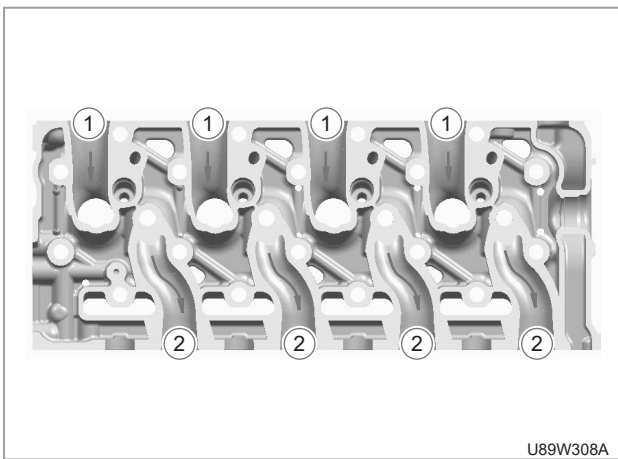

(1) Intake port (2) Exhaust port

The cylinder head is made of special alloy cast iron which can resist high temperature and pressure caused by combustion. The intake and exhaust ports are arranged cross-flow type to get high combustion efficiency by protecting the suction air from being heated and expanded by heated exhaust air.

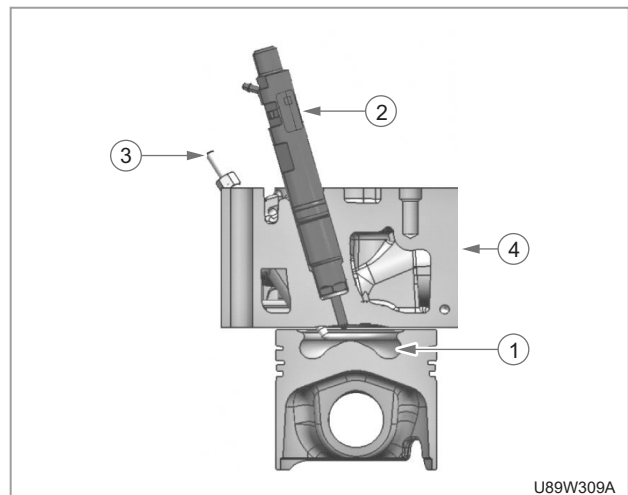

(1) Combustion chamber (2) Injection (3) Glow plug (4) Cylinder head

The HYUNDAI reentry type combustion chamber is designed for high combustion efficiency and reducing fuel consumption. The glow plug helps to start the engine even at -20°C (4°F).

3.2.2 CYLINDER BLOCK

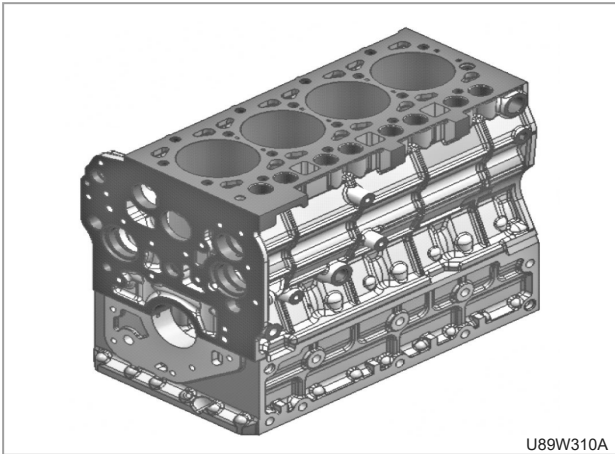

The cylinder block is a ladder frame type and it features superior serviceability and low vibration and noise compared to the conventional tunnel type.

3.2.3 CYLINDER HONING

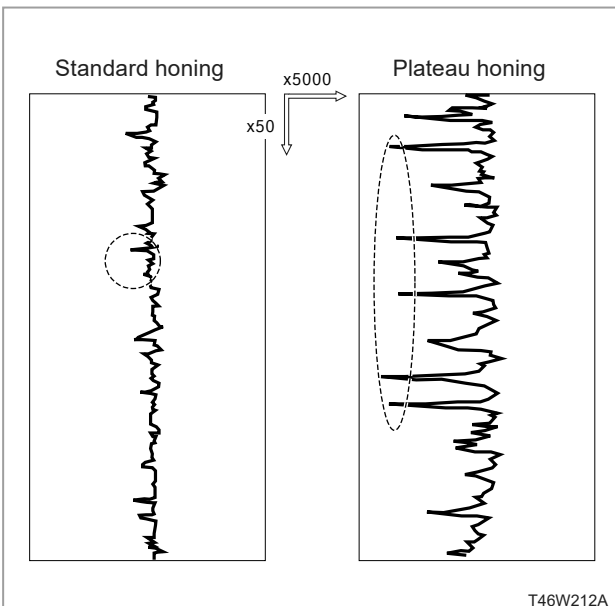

The HYUNDAI engine has adopted the plateau honing in manufacturing to enhance the oil tightness of the cylinder bore and the durability of the cylinder for the longer engine life time.

3.2.4 CRANKSHAFT

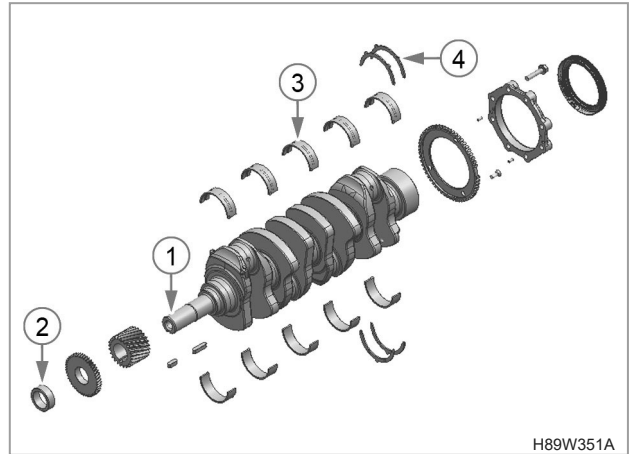

- (1) Crankshaft
- (2) Spacer
- (3) Crankshaft bearing 2
- (4) Thrust bearing (side metal)

The crankshaft is made of forged steel and the journals, the crankpins and the bearing surface for the oil seal are induction-hardened to increase wear resistance. Each crankshaft journal is supported by the cylinder block. The crankshaft, crankshaft bearings 2 (3) have oil holes for lubricant.

3.2.5 PISTON AND PISTON RING

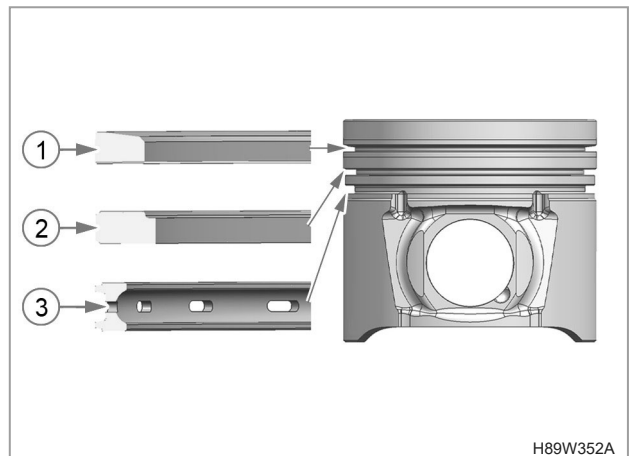

- (1) Top ring
- (2) 2nd ring
- (3) Oil ring

The piston is made of an aluminum alloy that is temperature and pressure resistant. Three rings are installed in the grooves of the piston. The top ring (1) is a keystone type, which can withstand heavy loads, and the barrel face on the ring fits well to the cylinder wall. The second ring (2) is an undercut type, which prevents the oil from being carried up. The oil ring (3) has chamfered faces and an expander ring, which increase the pressure of the oil ring against the cylinder wall to scrape the oil. The top ring is plated with hard chrome to increase wear resistance.

SAFETY FIRST

ENGINE

DRIVING & CHASSIS

HYDRAULIC SYSTEM

ELECTRIC SYSTEM

CABIN

INDEX

### 3.2.6 CONNECTING ROD

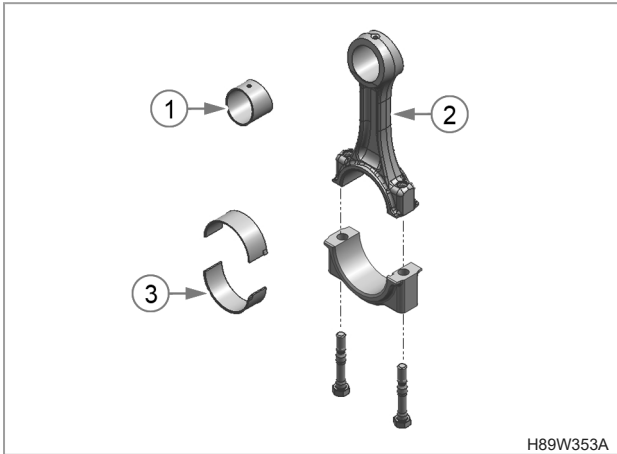

H89W353A

- (1) Small end bushing  
(2) Connecting rod  
(3) Crank pin bearing

The connecting rod (2), which converts the reciprocating motion of the pistons caused by the fuel combustion into the rotating motion of the crankshaft, is made of hard forged steel. The connecting rod has bearings at both ends. The small end has a cylinder type bearing (small end bushing (2)) and the big end has a split type bearing (crank pin bearing (3)).

### 3.2.7 CAMSHAFT

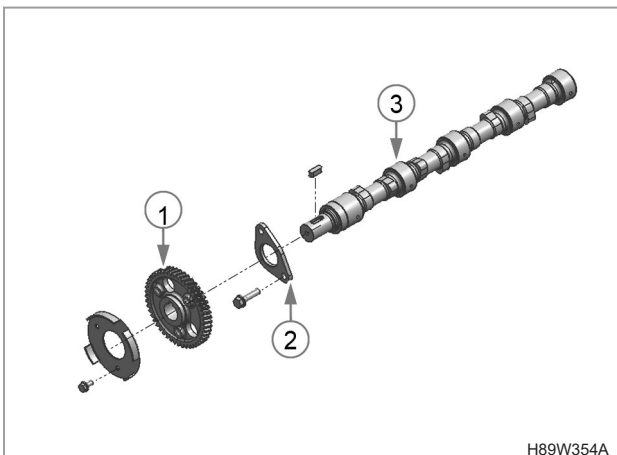

H89W354A

- (1) Camshaft gear  
(2) Camshaft stopper  
(3) Camshaft

The camshaft (3) is made of forged steel and its journal and cams are hardened to increase wear resistance. The cams on the camshaft open and close the intake and exhaust valves with the push rods and rocker arms. The journals and their bearings are force-lubricated.

### 3.2.8 ROCKER ARM ASSEMBLY

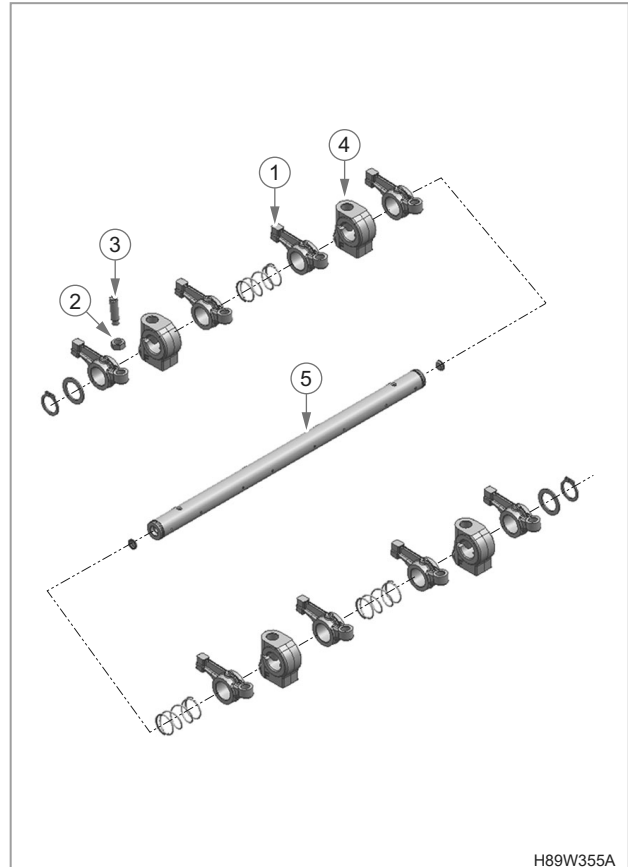

H89W355A

- (1) Rocker arm  
(2) Lock nut  
(3) Adjusting screw  
(4) Rocker arm bracket  
(5) Rocker arm shaft

The rocker arm assembly includes the rocker arms (1) and an adjusting screw (3), which is at the end of rocker arm and rests on the push rod, rocker arm brackets (4) and rocker arm shaft (5). The rocker arms are activated by the reciprocating movement of the push rods and open or close the intake and exhaust valves. The rocker arm and other parts are lubricated through the drilled holes of the brackets and the rocker arm shaft.



3.2.9 INTAKE AND EXHAUST VALVES

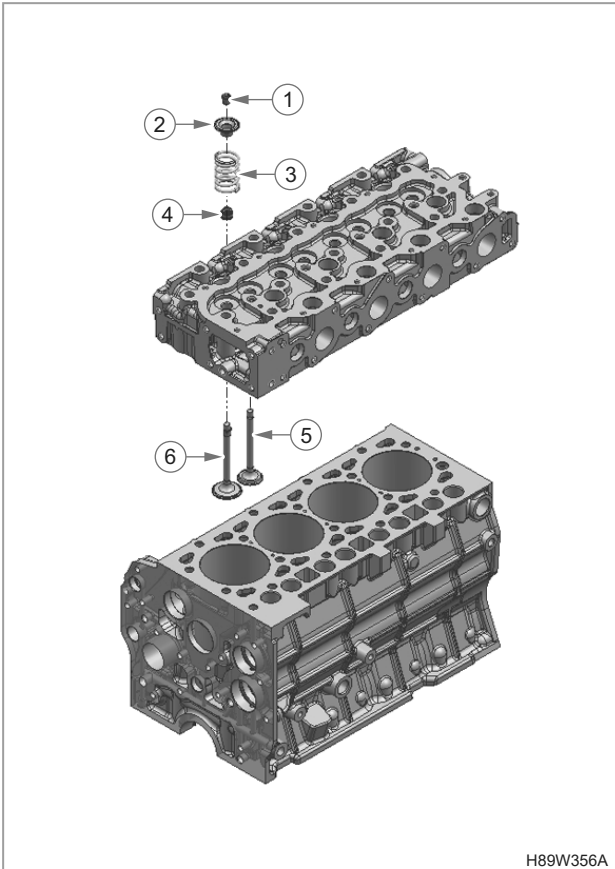

H89W356A

- (1) Valve spring collet
- (2) Valve spring retainer
- (3) Valve spring
- (4) Valve stem seal
- (5) Exhaust valve
- (6) Intake valve

The valve and its guide of the intake are different from those for the exhaust. Other parts, such as the spring, spring retainers, valve spring collets, valve stem seals are the same for both the intake and the exhaust.

The diameter of the intake valve is always larger than the that of the exhaust valve. The intake valve is located prior to exhaust valve when seeing them from the cooling fan side.

3.2.10 TIMING GEAR

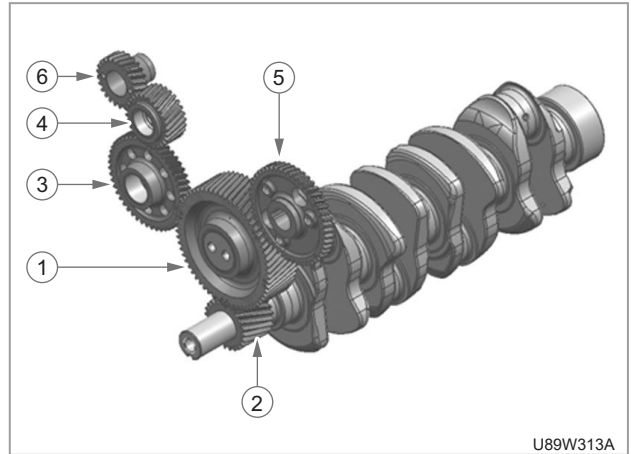

U89W313A

- (1) Idle gear 1
- (2) Crankshaft gear
- (3) Idle gear 3
- (4) Idle gear 4
- (5) Camshaft gear
- (6) High pressure fuel pump gear

The crankshaft drives the camshaft, idle gear, hydraulic pump drive gear and high pressure fuel pump gear. The timings for opening and closing the valves is extremely important to achieve the effective air intake and sufficient gas exhaust. When assembling, the appropriate timing can be obtained by aligning the mark on the crankshaft gear (2) with idle gear 1 (1), idle gear 1 with camshaft gear (5). Valve can be opened and closed at the correct timing when the idle gear 1 is aligned with the idle gear 3 (3), the idle gear 3 is aligned with the idle gear 4 (4) and the idle gear 4 is aligned with the high-pressure fuel pump gear (6) properly.

## 3.2.11 FLYWHEEL

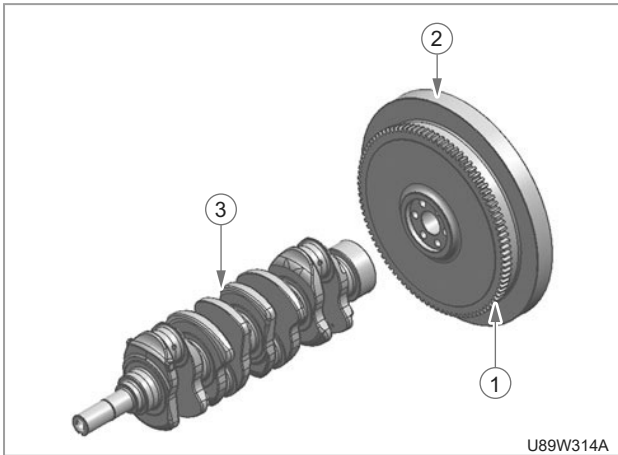

- (1) Ring gear  
(2) Flywheel  
(3) Crankshaft

The ring gear (1) for connecting the start motor is compressed in the flywheel. Therefore, it cannot be replaced separately.

## 3.2.12 MLS CYLINDER HEAD GASKET

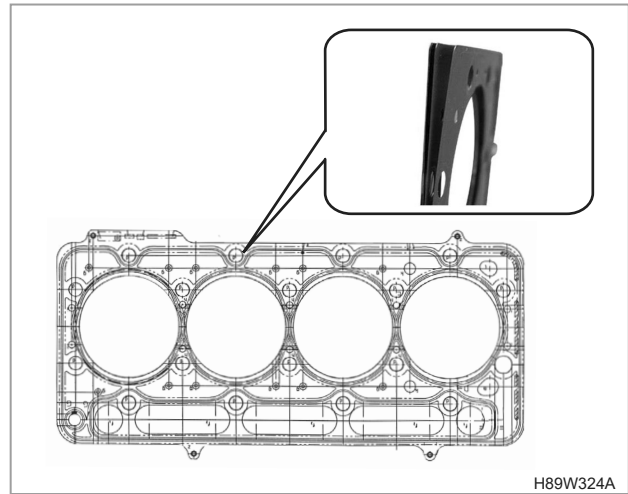

The MLS (Multi Layer Steel) cylinder head gasket has a 4-layered steel structure complemented with non-asbestos gasket features.

The top clearance variation is minimized and the thermal load is reduced while increasing durability.

**! CAUTION**

- When disassembling the cylinder head, its gasket should be replaced with a new one.
- Be sure that there is no scratch or foreign material between the cylinder head and the surface of the block.

3.3 LUBRICATING SYSTEM

3.3.1 ENGINE OIL FLOW

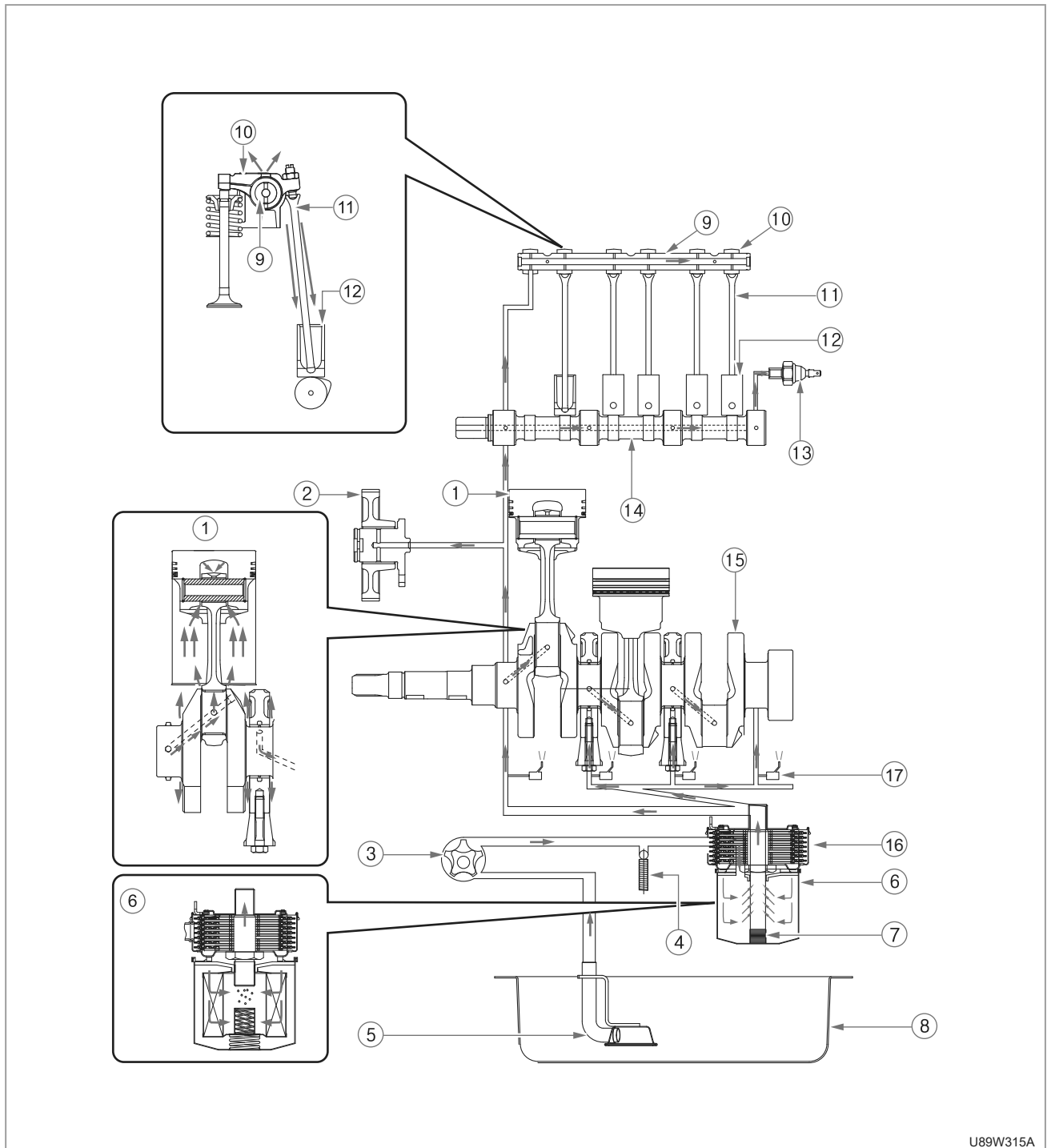

U89W315A

- |                  |                      |                         |
|------------------|----------------------|-------------------------|
| (1) Piston       | (7) Bypass valve     | (13) Oil pressure gauge |
| (2) Idle gear    | (8) Oil pan          | (14) Camshaft           |
| (3) Oil pump     | (9) Rocker arm shaft | (15) Crankshaft         |
| (4) Relief valve | (10) Rocker arm      | (16) Oil cooler         |
| (5) Oil strainer | (11) Push rod        | (17) Oil jet            |
| (6) Oil filter   | (12) Tappet          |                         |

SAFETY FIRST

ENGINE

DRIVING & CHASSIS

HYDRAULIC SYSTEM

ELECTRIC SYSTEM

CABIN

INDEX

3.3.2 ENGINE OIL FLOW CHART

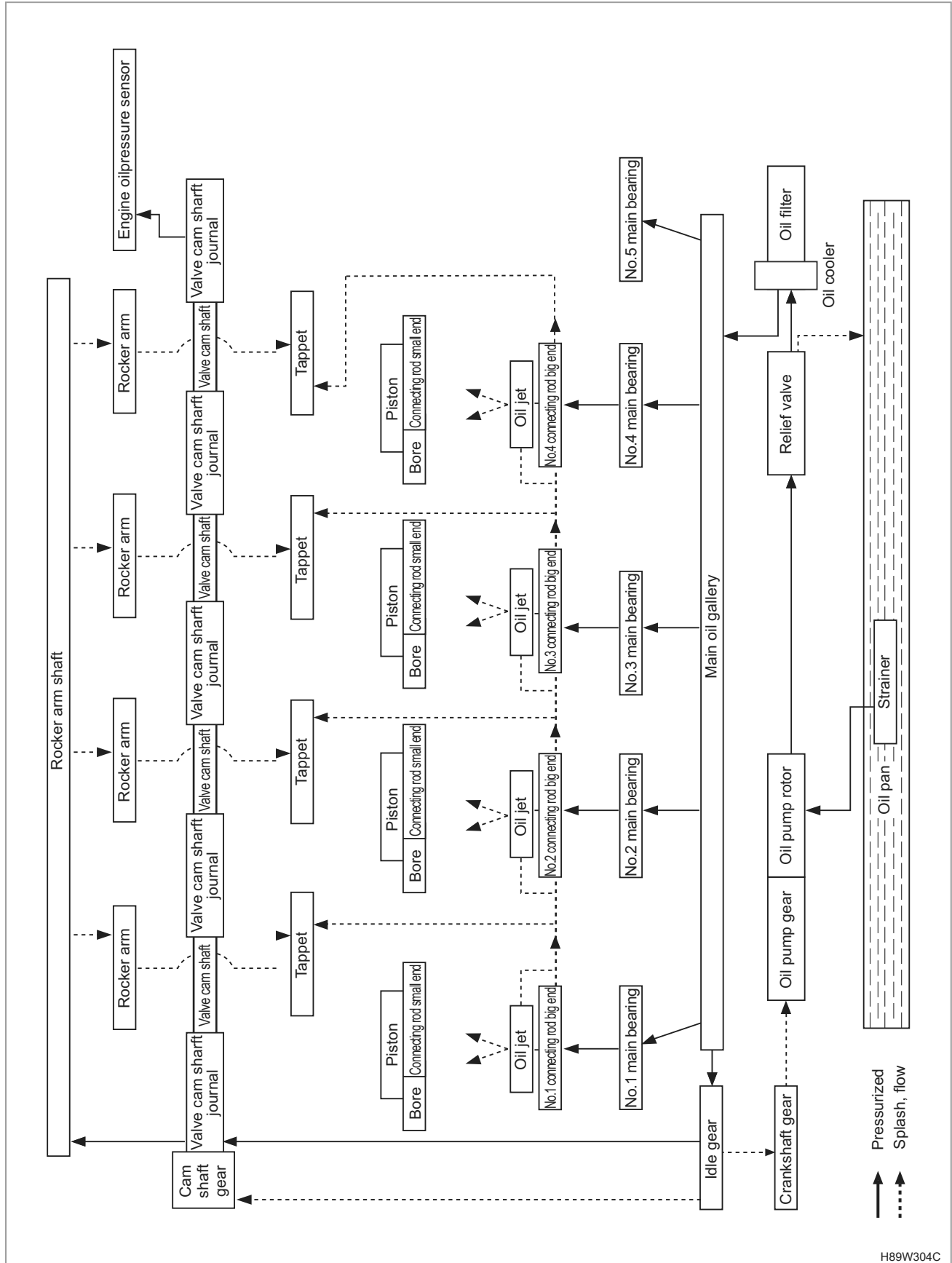

H89W304C

SAFETY FIRST

ENGINE

DRIVING & CHASSIS

HYDRAULIC SYSTEM

ELECTRIC SYSTEM

CABIN

INDEX

3.3.3 FUNCTION OF LUBRICATING SYSTEM

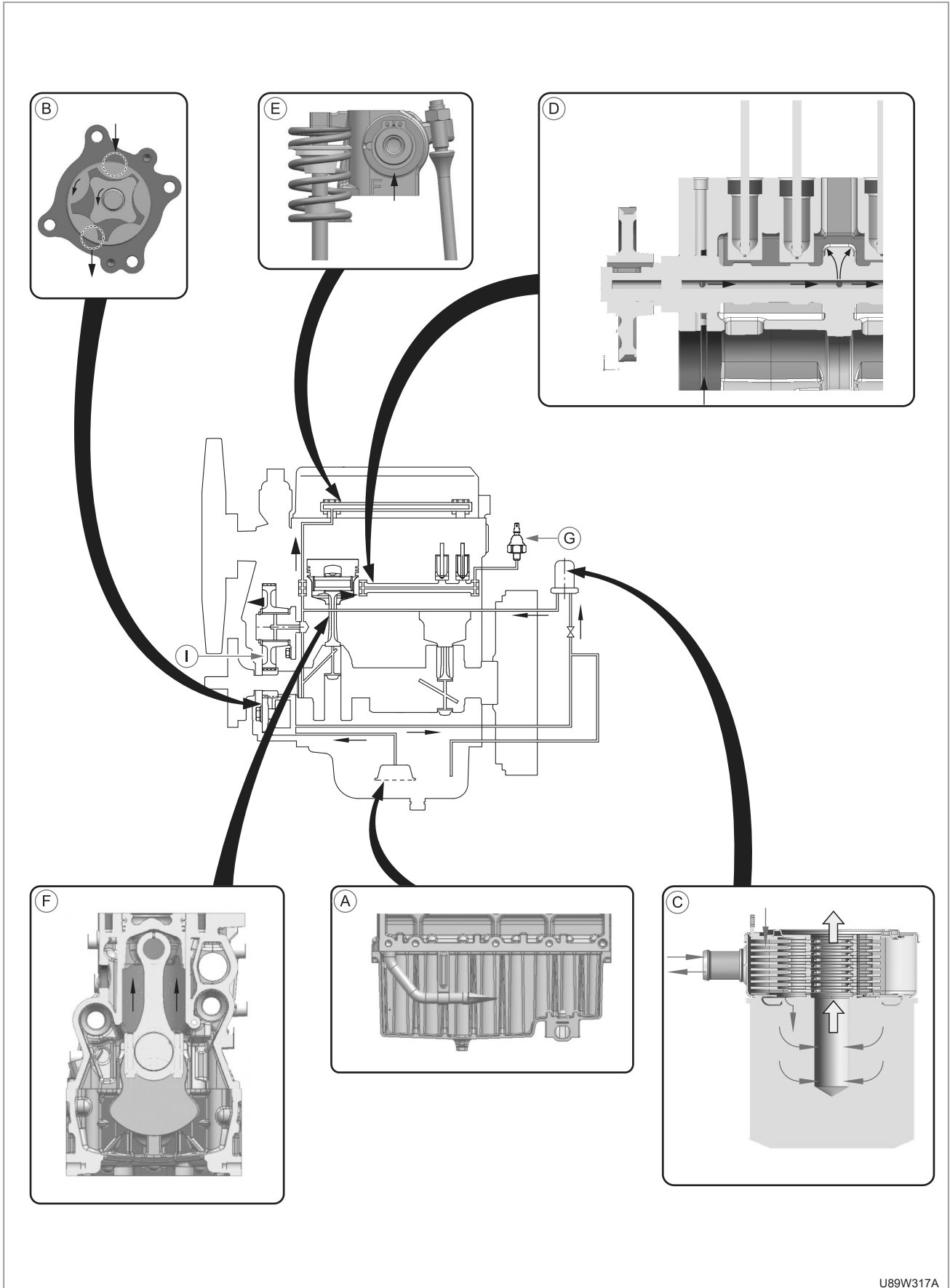

U89W317A

**OIL STRAINER (REFER TO FIGURE (A) ON 3.3.3)****OIL PUMP (REFER TO FIGURE (B) ON 3.3.3)**

Type: Gerotor type

Oil: Tier2, Tier3 - CH grade or higher  
Tier4, Stage-V - CJ grade or higher  
SAE 10W30/10W40/15W40

Standard oil temperature: 80°C

Discharge pressure: 4.5 kg/cm<sup>2</sup>

Displacement: Over 10.0 ℓ/min (1,000 rpm)  
Over 24.3 ℓ/min (2,000 rpm)

Drive gear speed ratio (oil pump drive gear/  
oil pump gear) = 46/41 = 1.121

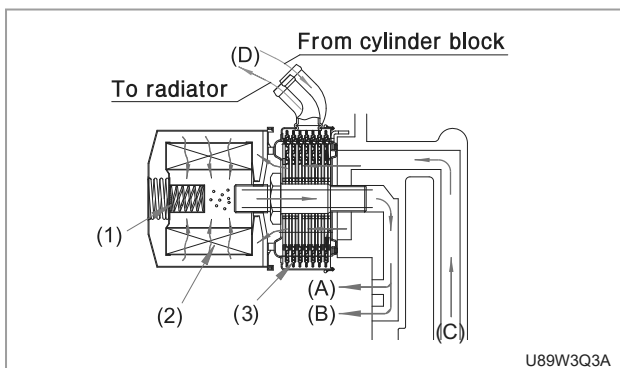
**OIL FILTER AND RELIEF VALVE**

- (1) Bypass valve  
(2) Filter element  
(3) Oil cooler

- (A) Oil filter outlet (to idle gear, camshaft and lock arm shaft)  
(B) Oil filter outlet (to oil gallery, oil jet, crankshaft journal)  
(C) Oil filter inlet  
(D) Coolant (Inlet - Outlet)

- Relief valve opening pressure: 4.0 ~ 4.5 kgf/cm<sup>2</sup>  
(57 ~ 64 psi)
- Oil filter
  - Filter paper fineness: Max.: 99 ± 5 microns,  
Average: 75 ± 5 microns
  - Filtered area: 1680 cm<sup>2</sup>
  - Bypass valve opening pressure (pressure difference  
between inner and outer side of filter paper):  
1 ± 0.2 kgf/cm<sup>2</sup>

**VALVE CAMSHAFT (REFER TO FIGURE (D) ON 3.3.3)**

The oil enters the first journal bearing of the valve camshaft and is sent to each journal through the oil holes in the center of the camshaft. Then, it is sent to the oil pressure sensor through the last journal.

**ROCKER ARM SHAFT (REFER TO FIGURE (E) ON 3.3.3)**

The oil from the valve camshaft comes through the hole in the support bracket of rocker arm, supplied to each rocker arm through the hole in the center of rocker arm shaft. The oil drained from the hole on top of the rocker arm is used in lubrication on the contact surface of the valve and the rocker arm. Then, it flows along the push rod to lubricate the contact surface between the push rod and the tappet and between the tappet and the valve cam.

**OIL FLOW (REFER TO FIGURE (F) ON 3.3.3)**

The oil in the oil gallery flows to the main bearing and then to the connecting rod big end journal bearing. Oil is sprayed to the connecting rod (small end), piston interior and cylinder bore by the oil jet that is installed to the oil gallery.

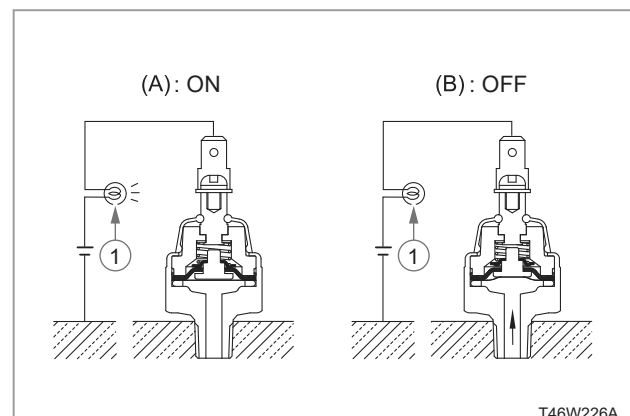
**OIL PRESSURE SWITCH (REFER TO FIGURE (G) ON 3.3.3)**

The oil pressure switch is installed on the cylinder block at the end of the valve camshaft and leads to the oil passage which is passing through the valve camshaft.

- A: When the oil pressure falls below the specified value, the circuit is connected by the diaphragm in the switch to turn on the warning lamp (1) on the instrument panel.
- B: When the key switch is turned to the "ON" position with the engine stopped, the warning lamp comes on. When the oil pressure rises, this lamp goes off.

Oil switch operating pressure(min.):

- 0.5 ± 0.1 kgf/cm<sup>2</sup>
- 7.1 ± 1.4 psi
- 49 ± 9.8 kPa

**3.4 COOLING SYSTEM**  
**3.4.1 COOLANT FLOW ROUTE**

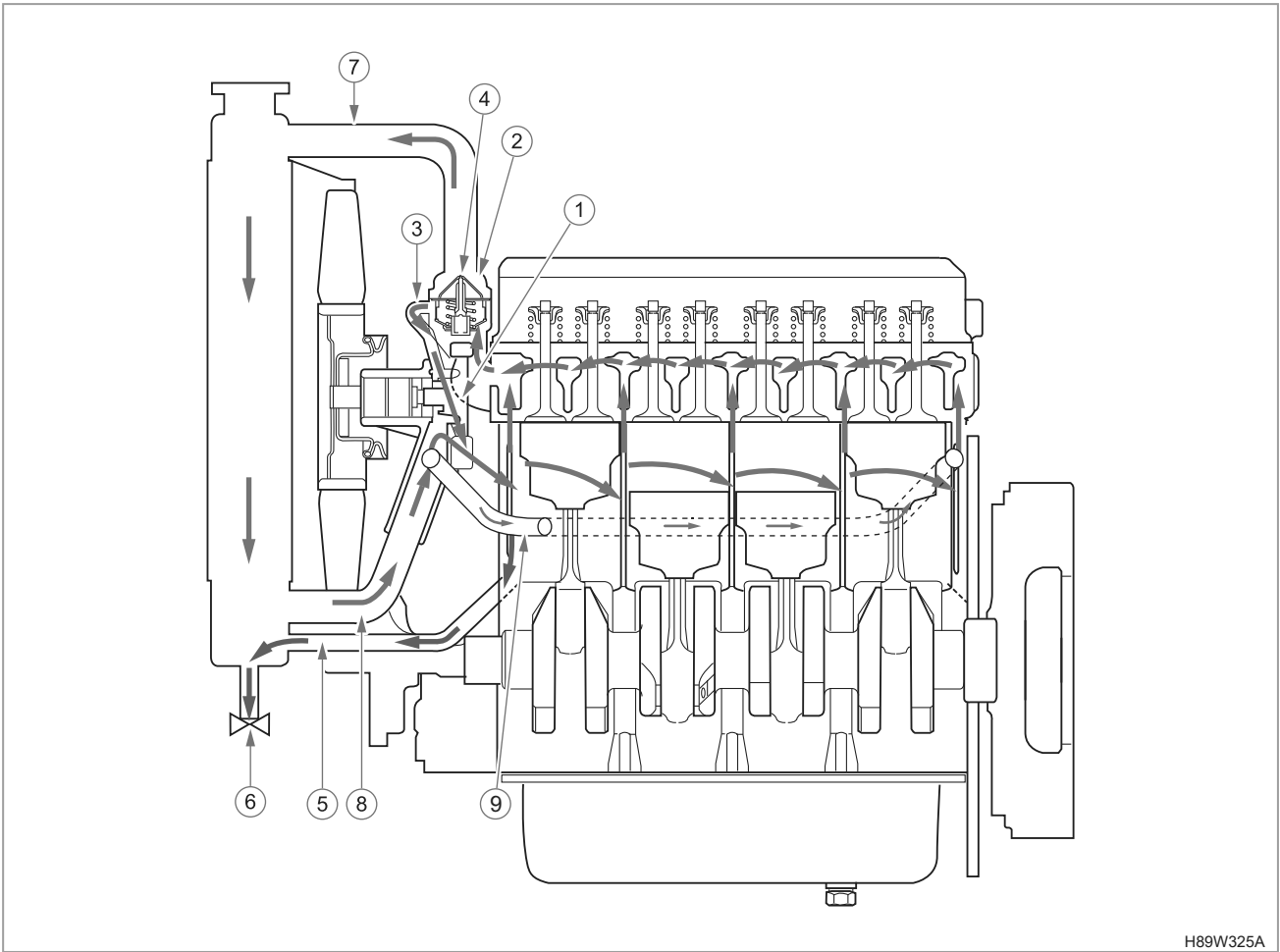

When the centrifugal water pump (1) connected to the cooling fan shaft rotates, the coolant in the cylinder block flows from the No. 1 cylinder to the No. 3 and No. 4 cylinders through the No. 2 cylinder, and also flows to the cylinder head (from lower to upper side). In the cylinder head, the coolant flows from the No. 4 cylinder to the No. 1 cylinder through the No. 2 and No. 3 cylinders (from rear to front side).

The coolant collected in the coolant flange (2) flows to the inlet of the water pump impeller through the return hose (3), and then returns to the cylinder block through the outlet of the impeller.

When the coolant temperature rises over 71°C (160°F), the thermostat (4) opens and most coolant flows to the radiator through the thermostat. The coolant flowed to the top of the radiator through the top hose (7) is cooled down by the cooling air and sinks. Then, it flows to the inlet of the water pump impeller through the radiator lower hose (8) to return to the cylinder block.

The drain hose (5) is to completely drain the coolant in the cylinder block when opening the radiator lower cock (6).

On the other hand, the vehicle equipped with the cabin heater has the cooling circuit that draws in hot water from the coolant flange (2) to heat the heater and drains it through the lower hose of the radiator.

Also, for the engine equipped with the engine oil cooler cools down the engine oil by connecting the water pump(1) drain line to the engine oil cooler.

Also, for the CRDI (Common Rail Direct Injection) engine, part of coolant escapes the impeller inlet passage of the water pump through the lower hose of the radiator and flows to the ERG cooler (9) to cool down some exhaust gas flowing to the intake manifold.

3.4.2 WATER PUMP

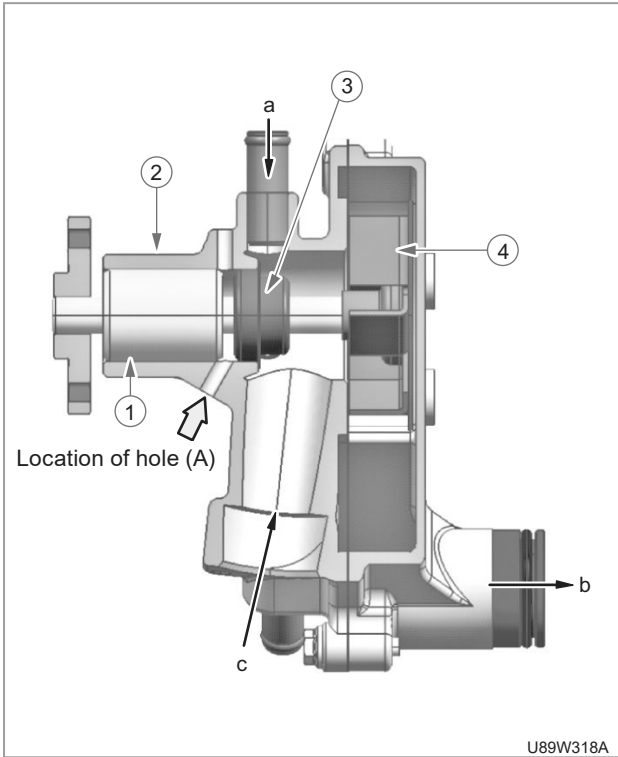

- (a) From thermostat
- (b) To cylinder block
- (c) From radiator
- (1) Bearing
- (2) Pump body
- (3) Mechanical seal
- (4) Pump impeller

The water pump sucks the cooled water, forces it into the cylinder block and draws out the hot water to the radiator repeatedly. The mechanical seal (3) prevents the water from entering into the bearing (1).

**REMARKS**

- If the coolant is leaked from hole (A), it means that the mechanical seal is damaged. Therefore, the water pump assembly should be replaced.

3.4.3 THERMOSTAT

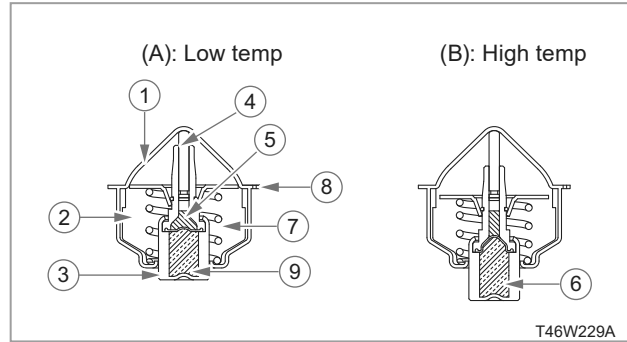

- (1) Seat
- (2) Valve
- (3) Pellet
- (4) Spindle
- (5) Synthetic rubber
- (6) Wax (Solid)
- (7) Spring
- (8) Leak hole
- (9) Wax (Liquid)

The thermostat is wax pellet type, which controls the flow of the cooling water to the radiator to keep the proper temperature. The case has a seat (1) and the pellet has a valve (2). The spindle attached to the case is inserted into the synthetic rubber in the pellet. The pellet is charged with wax.

**AT LOW TEMPERATURE: BELOW 82°C (180°F)**

The valve (2) is seated by the spring (7) and the cooling water circulates in the engine through the water return pipe but does not enter the radiator.

**AT HIGH TEMPERATURE: OVER 82°C (180°F)**

As the water temperature rises, the wax in the pellet (3) becomes liquid and it pushes out the spindle.

The pellet lowers and the valve (2) opens to send the cooling water to the radiator.



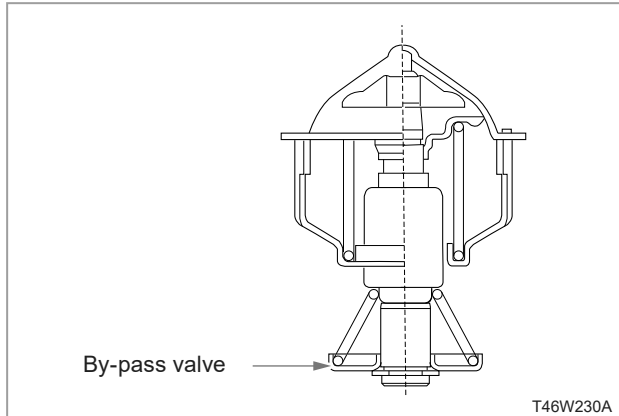

The bypass valve is equipped in the bottom of thermostat. Therefore, the cooling efficiency is enhanced as all coolant passes through the radiator since the internal circulation circuit is blocked as soon as the thermostat opens.

**3.4.4 RADIATOR**

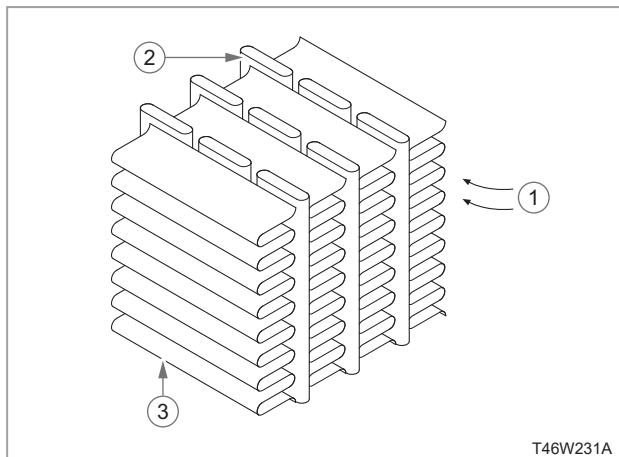

(1) Cooling air                      (3) Pin  
(2) Tube

The radiator core consists of water tubes (2) with fin (3) at a right angle to it. The water in the radiator is cooled down by the air flowing between the tube wall and the fin.

**3.4.5 RADIATOR CAP**

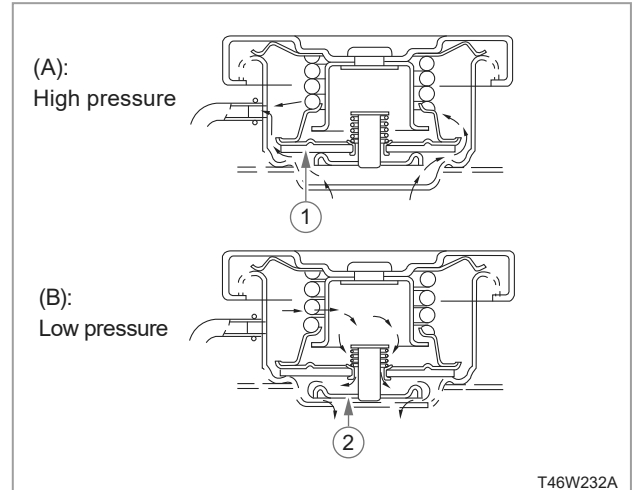

(1) Pressure valve                      (2) Vacuum valve

The radiator cap is equipped with the pressure valve (1) and vacuum valve (2).

**AT HIGH PRESSURE - OVER 88 kPa (0.9 kgf/cm<sup>2</sup>, 13 psi)**

When the water temperature rises and the pressure in the radiator increases above the specified value, the pressure valve (1) opens to drain the coolant to the reservoir tank to reduce the internal pressure.

**AT LOW PRESSURE**

When the water temperature drops down and a vacuum is generated in the radiator, the vacuum valve (2) opens to allow the coolant in the reservoir tank to enter into the radiator.

3.4.6 CLUTCH FAN

SAFETY FIRST

ENGINE

DRIVING & CHASSIS

HYDRAULIC SYSTEM

ELECTRIC SYSTEM

CABIN

INDEX

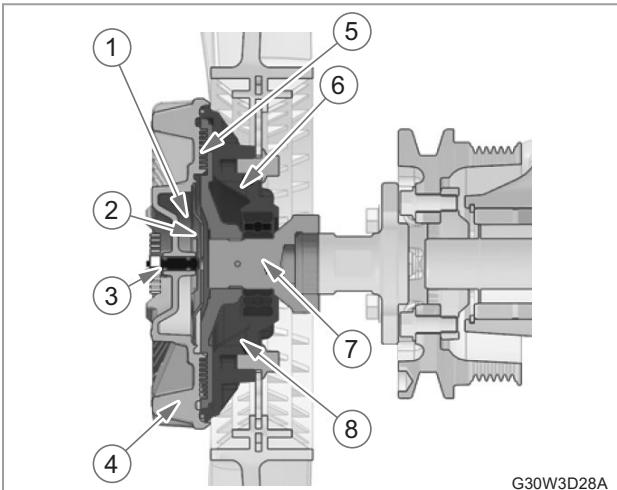
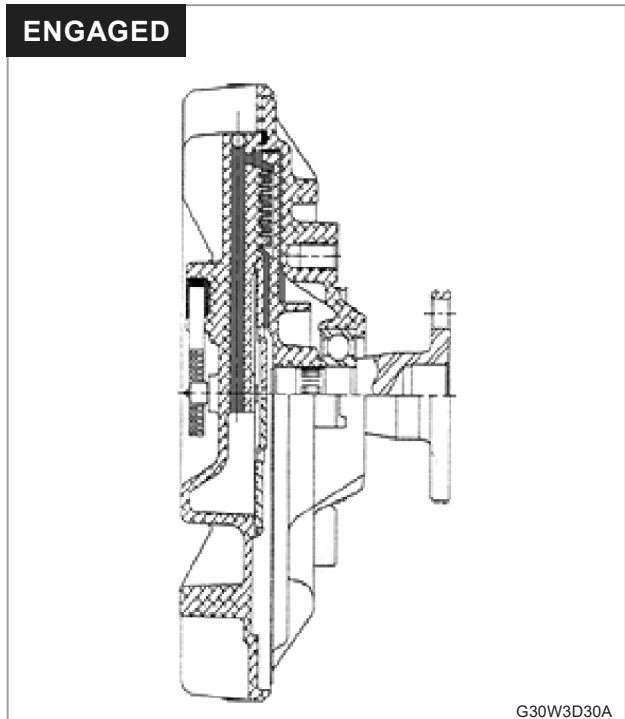
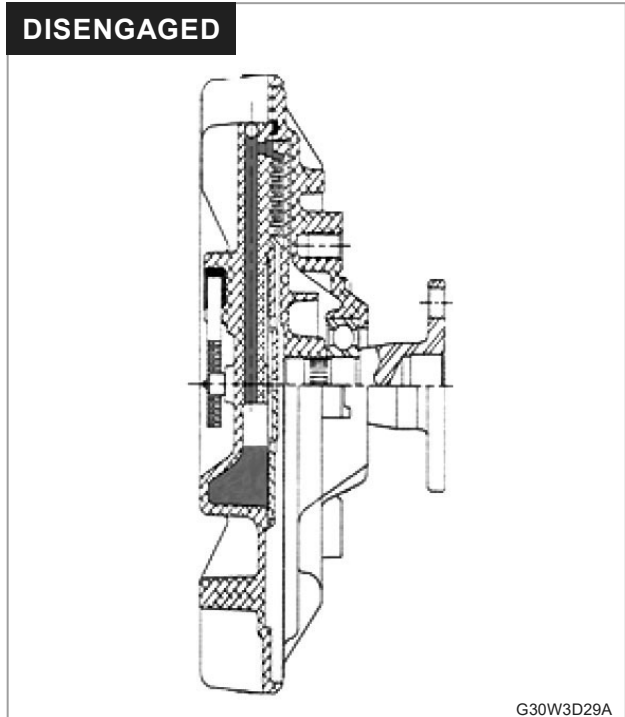
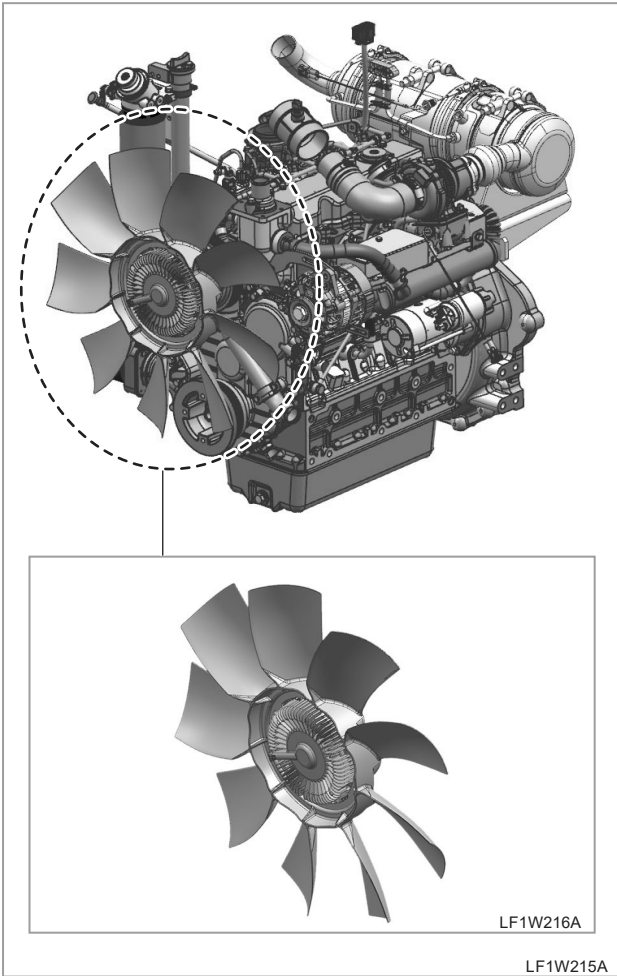

- (1) Silicone fluid
- (2) Storage chamber
- (3) Bi-metallic coil
- (4) Cover
- (5) Operating chamber
- (6) Clutch
- (7) Shaft
- (8) Body

The clutch fan uses a bi-metallic strip on the front of the clutch to reduce fuel consumption and fan noise by keeping the fan rpm low in cold weather and increasing the fan rpm in hot weather. The fan also speeds up the warm-up process of the machine by keeping the fan rpm low in winter or low load conditions.

After being sufficiently heated by the radiator, air causes the bi-metallic strip to expand and the valve opens as silicone fluid stored in the storage chamber moves to the operating chamber and the clutch is rotated by the torque generated. Usually, in cold weather, the fan maintains a low rpm regardless of the engine rpm and maintains the maximum rpm when the temperature around the bi-metallic strip increases sufficiently.

Mechanical clutch fans which use silicone fluid have a slip rate of 5 – 10% of the normal input rpm.

**⚠ CAUTION**

- When the clutch fan is placed in storage, silicone may leak if the part with the shaft mounted is facing downwards, so make sure to store it either facing the opposite direction or upright.

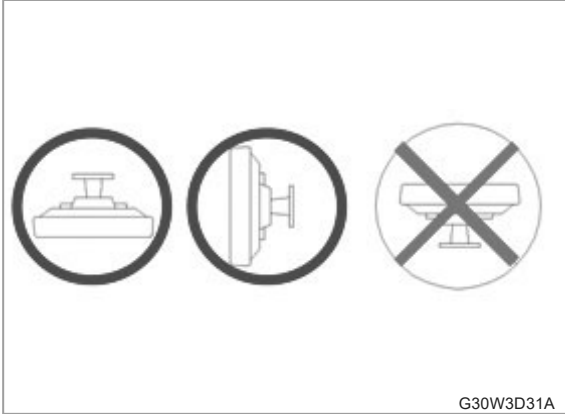

(If the fan is not used for a prolonged period of time, the rpm may temporarily appear higher than the disengaged rpm due to silicone in the storage chamber in low temperature conditions.)

### 3.5 FUEL SYSTEM

#### 3.5.1 OVERVIEW FOR FUEL SUPPLY

The common rail fuel injection system is comprised of the fuel tank, fuel line, fuel filter, high-pressure fuel pump equipped with high/low pressure pumps for fuel supply, common rail to distribute/store high-pressure fuel, injector to inject high-pressure fuel precisely, and ECU (Electronic Control Unit) which calculates acceleration (position of the accelerator pedal) desired by the driver based on information from various sensors and controls instant performance of the engine and vehicle in general.

#### 3.5.2 FUEL FLOW ROUTE

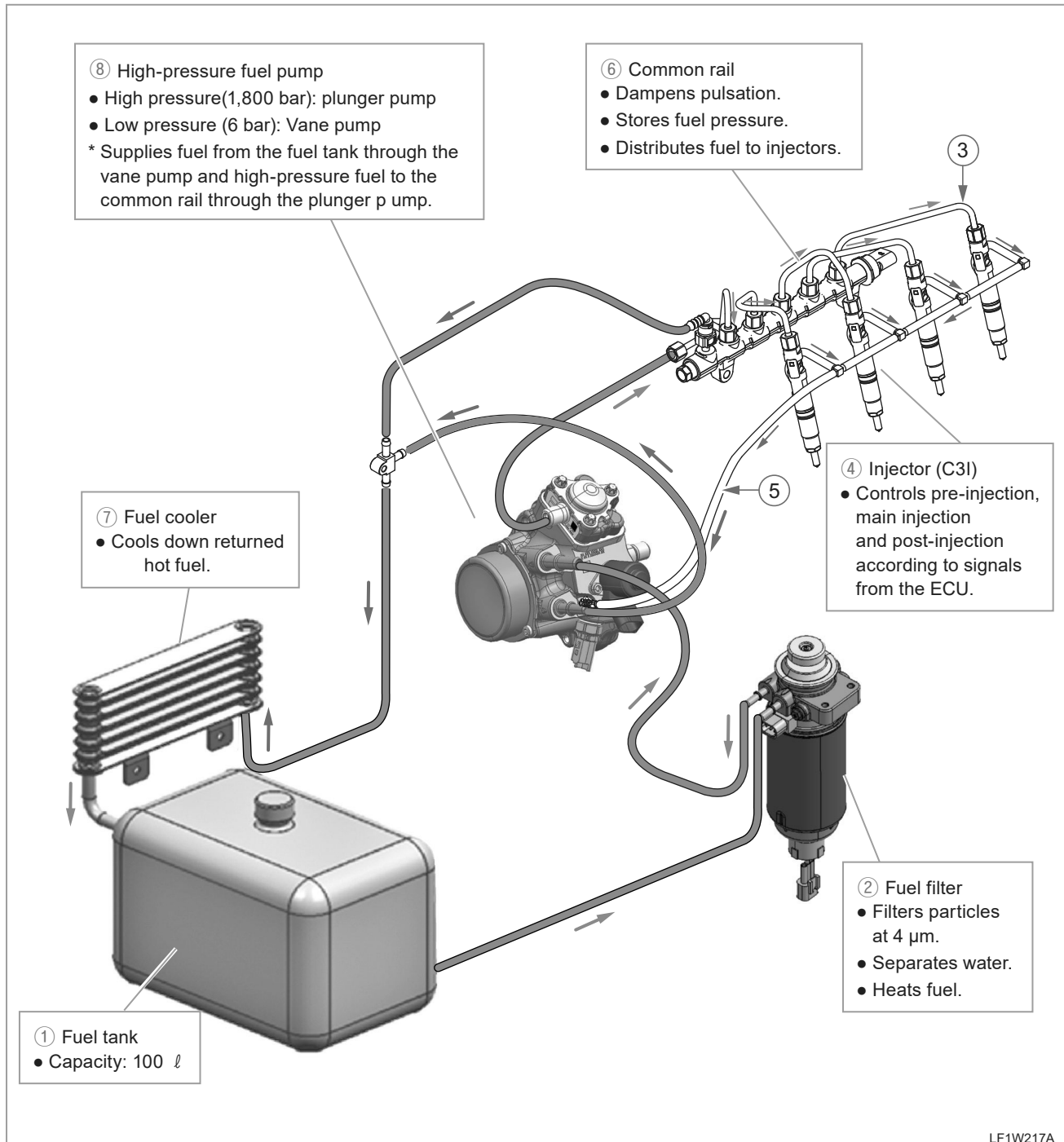

- (1) Fuel tank
- (2) Fuel filter
- (3) Injection pipe

- (4) Injector
- (5) Fuel return hose
- (6) Fuel Rail

- (7) Fuel cooler
- (8) High pressure fuel pump

**FUEL SYSTEM FLOW DIAGRAM**

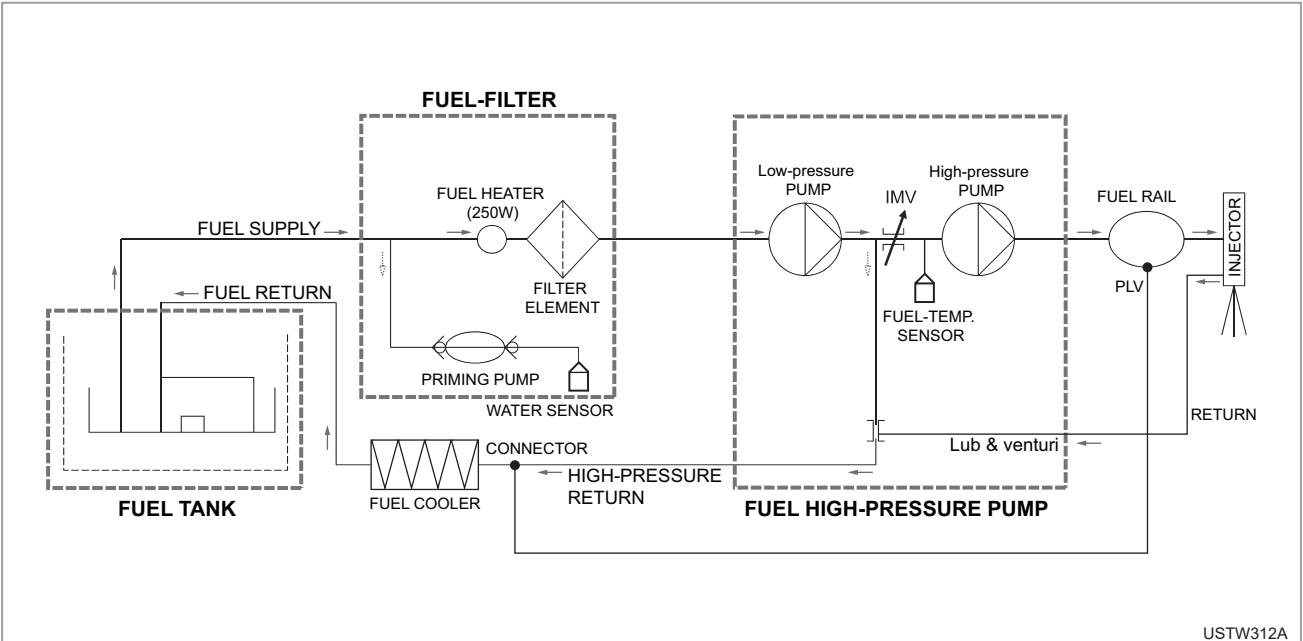

Fuel sucked from the fuel tank passes the fuel filter and flows into the high-pressure pump from the low-pressure pump in the high-pressure fuel pump. After it is pressurized in the high-pressure pump, it is flowed to the fuel rail and is injected through the injectors according to the fuel injection signal for each injector. The ECU controls the IMV to control the fuel flow according to the pressure needed for the fuel rail. Fuel in the injector is returned to the high-pressure pump and then is drawn into the fuel cooler through the return line to cool down and send this fuel back to the fuel tank. If pressure between the high-pressure pump and fuel rail rises abnormally, the PLV(Pressure Limit Valve) of the fuel rail (common rail) opens to release pressure.

**REMARKS**

- For air bleeding, see the 3.5.4 BLEEDING THE FUEL SYSTEM.

## 3.5.3 FUEL FILTER

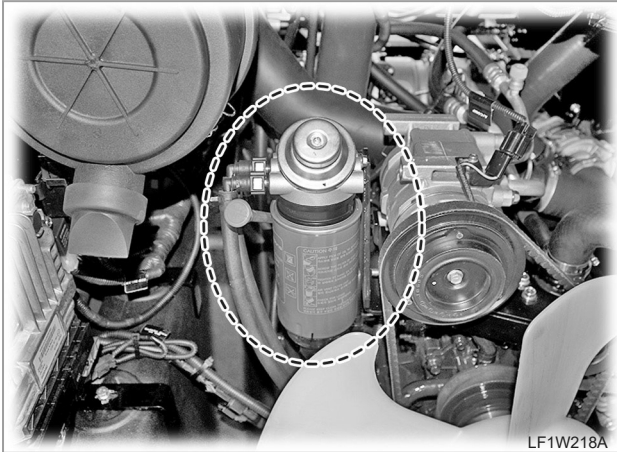

LF1W218A

If water is mixed in fuel, fuel can be frozen in winter, making the engine hard to start or occurring wear, damage and corrosion across the fuel supply system, resulting in breakdown.

Therefore, water and foreign materials should be filtered thoroughly from fuel with the fuel filter.

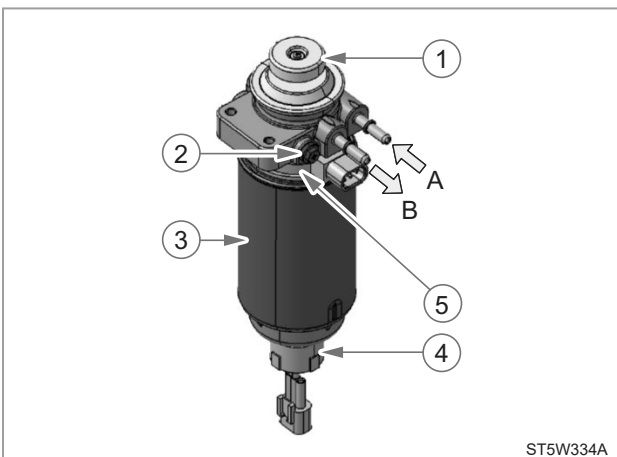

ST5W334A

- |                            |                     |
|----------------------------|---------------------|
| (1) Priming pump           | (A) from fuel tank  |
| (2) Bleeding bolt          | (B) to HP fuel pump |
| (3) Filter ass'y           |                     |
| (4) Water detection sensor |                     |
| (5) Fuel heater            |                     |

As fuel from the fuel tank enters the fuel filter through its port (A), it flows through the filter element and then is supplied to the HP fuel pump through the port (B). The element in the fuel filter filters foreign materials over 4 microns in thickness at differential pressure of 10 kPa (0.1 kgf/cm<sup>2</sup>, 1.45 psi). This fuel filter is not only to filter water and foreign materials from fuel, but also to preheat fuel. As diesel fuel tends to freeze on a low temperature condition, making the engine hard to start, this fuel filter is equipped with the fuel heater to avoid this situation.

## ► Water-in-fuel sensor

If a certain amount of water (45 cc or more) is accumulated in the filter, this sensor sends a signal to the ECU to turn on the corresponding warning lamp in order to inform the driver to drain water from the filter.

## ► Fuel heater

When the ambient temperature is below 5°F (-15°C), some ingredients of diesel fuel start to gel, leading to engine stall. Therefore, the fuel heater is operated continuously to prevent engine stopping once the engine is started..

## ► Priming pump

After the fuel tank becomes empty, removing water from the fuel filter or replacing the fuel filter, air remains in the fuel system. To remove this air, press the priming pump repeatedly with the bleeding bolt open until fuel is drained from the tank.

## ! CAUTION

- Fuel in the fuel tank should be sent to the filter by using the priming pump after replacing the fuel filter. Never crank the engine to operate the high-pressure pump in order to send fuel in the fuel tank to the filter after replacement.

## ! IMPORTANT

- If water is collected in the fuel more than the specified, the corresponding warning lamp on the instrument cluster is illuminated. In this case, drain water from the filter.
- When replacing the fuel filter, replace it with the priming pump if possible.

### 3.5.4 BLEEDING THE FUEL SYSTEM

1. Make sure that the amount of fuel in the fuel tank is sufficient.
2. If air is mixed in the fuel filter, unscrew its bleeding bolt (2), shown in the figure for the fuel filter, and press the priming pump continuously. Then, air in the fuel filter is bled through the bleeding bolt.



#### CAUTION

- **Avoid to run the start motor for over 5 consecutive seconds, but run it several times at shorter intervals.**



#### REMARKS

- **If filling the port with fuel before installing the fuel port, it is not necessary to bleed the filter.**

3. If fuel is visible from the bleeding bolt, tighten it and start the engine.

3.5.5 HIGH PRESSURE FUEL PUMP

COMPONENT

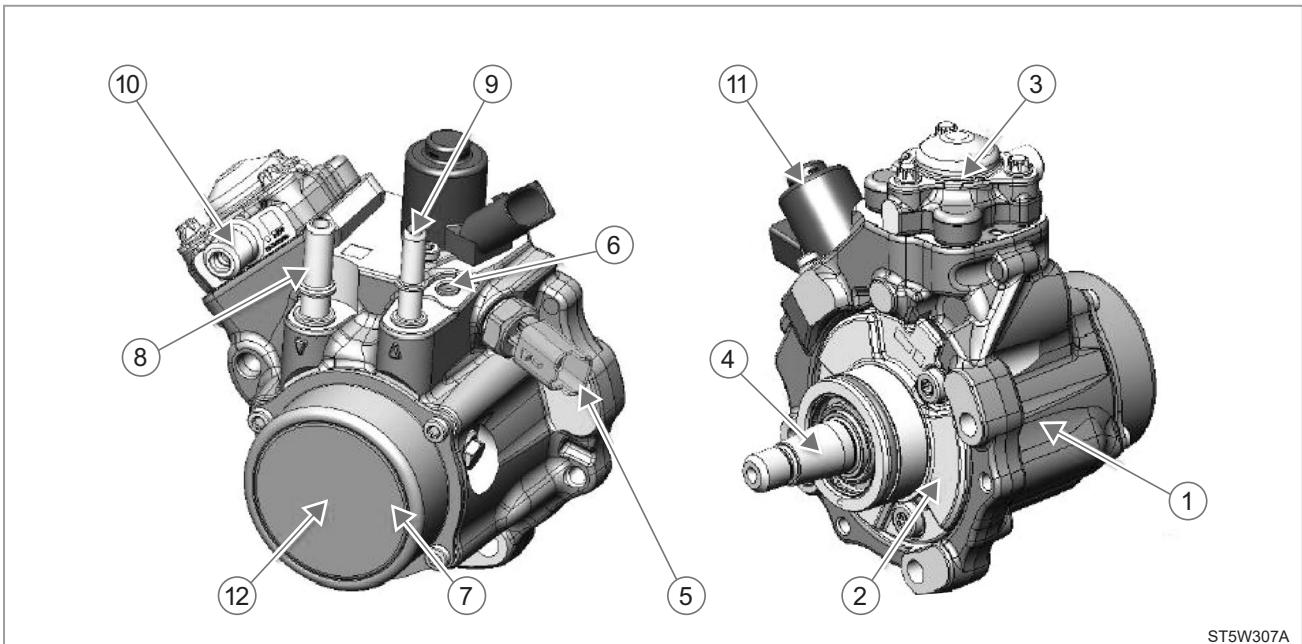

ST5W307A

- |                    |                            |                                 |
|--------------------|----------------------------|---------------------------------|
| (1) Housing        | (5) Fuel temperatur sensor | (9) Pump backleak connector     |
| (2) Front plate    | (6) Venturi voss connector | (10) HP outlet connector        |
| (3) Hydraulic head | (7) Fuel transfer pump     | (11) Inlet metering valve (IMV) |
| (4) Drive shaft    | (8) Pump inlet connector   | (12) Pump identification label  |

MAJOR COMPONENT SPECIFICATIONS

ITEM	FUNCTION	SPECIFICATION
Low pressure pump	<ul style="list-style-type: none"> <li>Supplying fuel from fuel tank to high-pressure fuel pump</li> <li>Driven by shaft of high-pressure fuel pump</li> </ul>	Pumping capacity: 5.6 cc/rev
Pressure control valve (IMV)	<ul style="list-style-type: none"> <li>Controlling amount of fuel sent from low-pressure side to high-pressure fuel pump to match ECU-commanded pressure and actual fuel rail pressure</li> </ul>	-

SAFETY FIRST

ENGINE

DRIVING & CHASSIS

HYDRAULIC SYSTEM

ELECTRIC SYSTEM

CABIN

INDEX



**IMV (INLET METERING VALVE)**



U89W3T0A

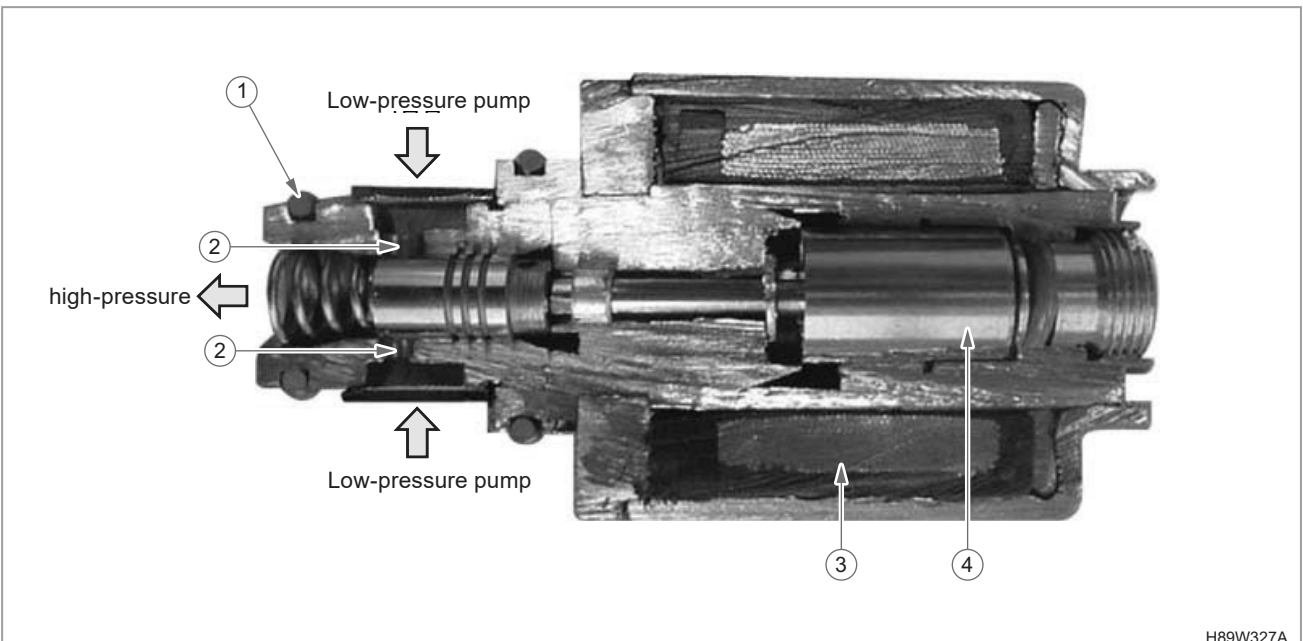

H89W327A

- (1) Cylinder filter
- (2) Radial hole
- (3) Solenoid coil
- (4) Piston

The IMV (Inlet Metering Valve) is installed on the front of the high-pressure fuel pump and it is supplied with fuel from the transfer low-pressure pump through 2 radial orifices.

This valve is also called as low-pressure actuator and is used to control the rail pressure by adjusting fuel amount sent to the pumping section of the high-pressure pump.

It adjusts the fuel amount to keep pressure in the fuel rail constant for more effective injection system. It also limits the amount of fuel returned to the high-pressure pump to prevent excessively high temperature of fuel in the fuel tank due to excessively hot fuel sent from the injectors.

- Components: : piston, piston filter, O-ring, body and coil
- Function

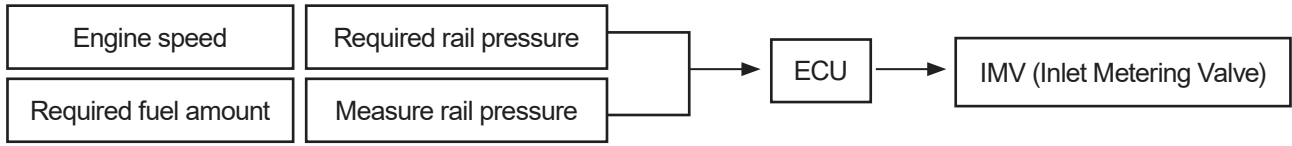

## 3.5.6 COMMON RAIL (FUEL RAIL)

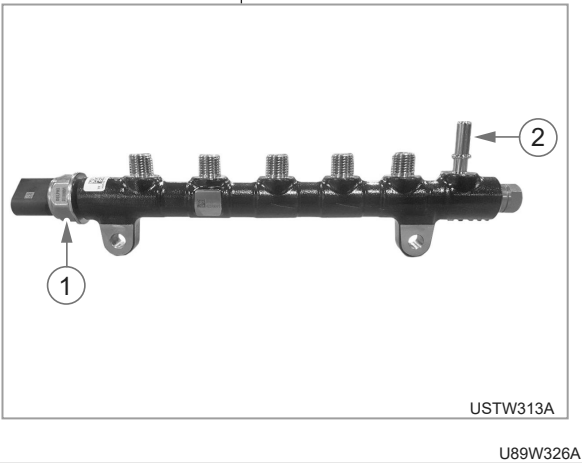
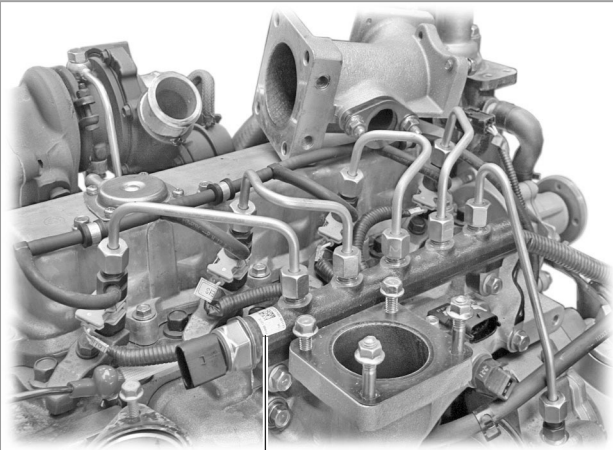

(1) Fuel pressure sensor (2) PLV(Pressure Limit Valve)

The Delphi DFR 4.18 PLV fuel rail stores and distributes high-pressure fuel to the injectors for fuel injection.

Therefore, it is commonly used by all cylinders, and it maintains its internal pressure continuously by itself even when the injectors open and pressure drops.

Over pressure protection is ensured by the Pressure Limit Valve(PLV) located on the rail. PLV opening pressure is  $2,350 \pm 100$  bar.

## FUEL PRESSURE SENSOR

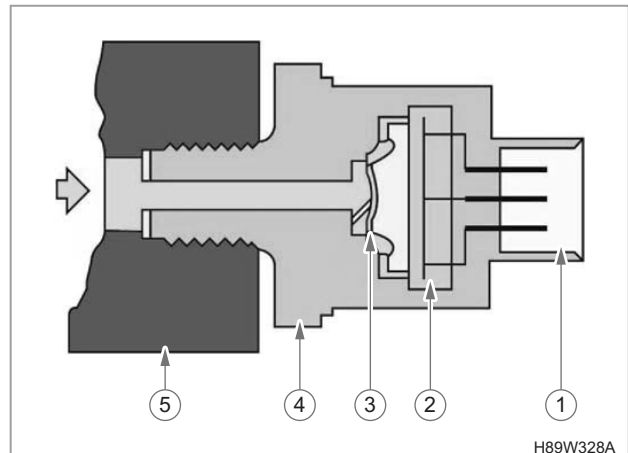

- (1) Connector
- (2) Measuring circuit
- (3) Sensor element (diaphragm)
- (4) Fuel rail pressure sensor assembly
- (5) Fuel rail

The fuel pressure sensor (1) with the capacity of 0 to 2,500 bars is installed to the side of the fuel rail. It detects the instant change in the fuel pressure, converts this information to a voltage signal and sends this to the ECU which then controls pressure of the fuel rail precisely.

The pressure in the fuel rail is determined by the engine RPM, engine torque, barometric pressure, coolant temperature and intake temperature. Also, the ECU receives and uses this information to adjust the fuel injection amount and injection timing for the injector of each cylinder.

3.5.7 INJECTOR [C3I (CALIBRATION IMPROVED INDIVIDUAL INJECTOR)]

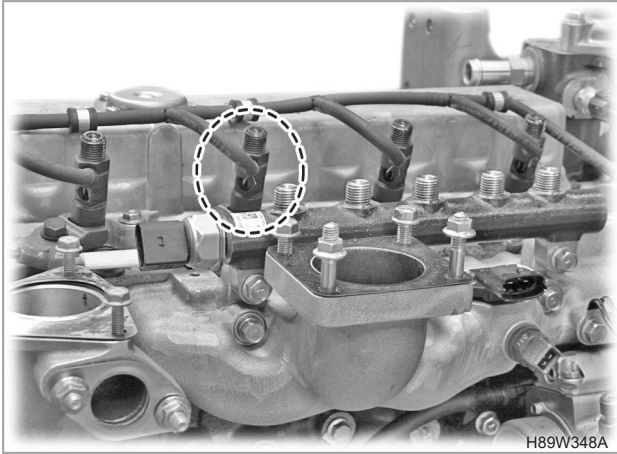

This Delphi DFI 2.20S solenoid type injector is capable of multiple injections for each injection timing within a short period of time with the maximum nozzle opening pressure of 1,800 bar (1,835 kgf/cm<sup>2</sup>, 26,106 psi) and features low noise, low vibration and low fuel consumption through electronic control by the ECU.

The injector starts fuel injection at least at 300 bars and up to 1,800 bar.

INJECTOR CORDIFICATION

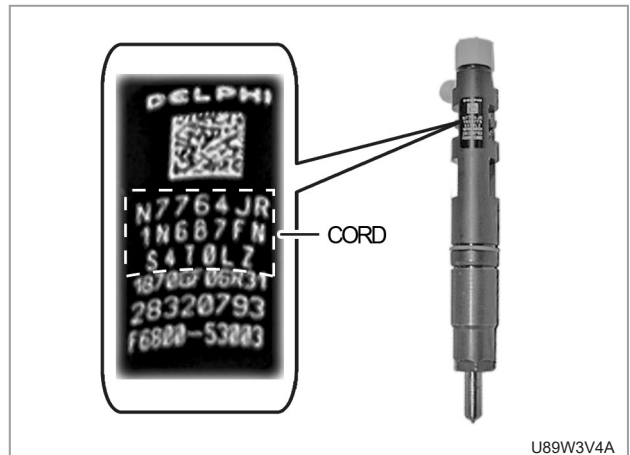

The code C3I is marked on the side of the injector and cylinder head cover. This code consists of 20 digits including numbers from 1 to 9 and alphabetic characters excluding I, O, Q and V.

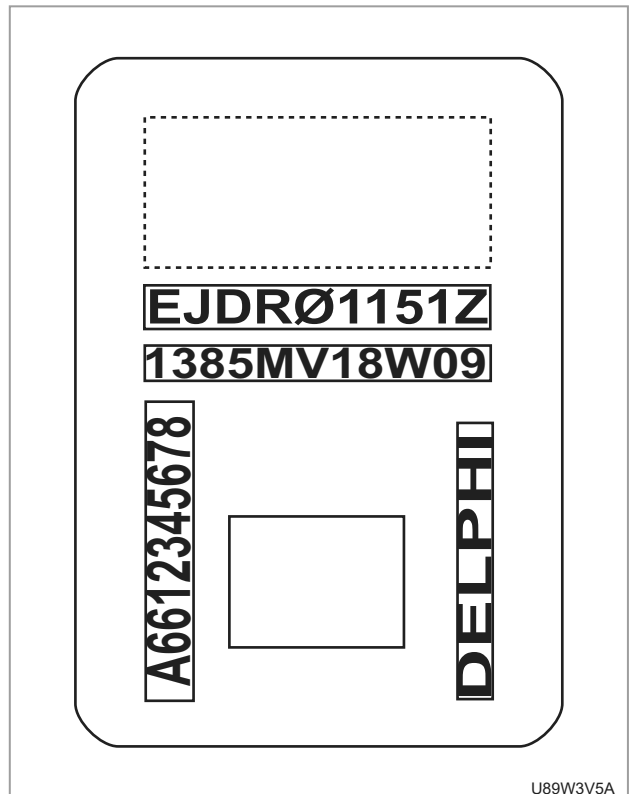

\* 20 digits with combination of alphabetic characters and numbers

- Alphabetic characters: A, B, C, D, E, F, G, H, J, K, L, M, N, P, R, S, T, U, W, X, Y, Z

- Numbers: 0, 1, 2, 3, 4, 5, 6, 7, 8, 9

**! IMPOARTANT**

- When installing the injector (new) to the cylinder block, connect the ECU to the scan tool and enter the injector code (20 digits) specified on the top of the injector into the scan tool.

**REMARKS****MDP (MINIMUM DRIVE PULSE) LEARNING**

- When the injector starts injecting fuel, this initial pulse value is measured to correct the pilot injection efficiently through the MDP control. Since the amount of fuel for pilot injection is very small (1 to 2 mm/st), it is hard to control the injectors precisely as they get aged. Therefore, injection amount and condition of the injectors are learned for consistent precise control over the injectors so that the ECU can adjust the pilot injection effectively. The MDP is learned by the knock sensor.

**! CAUTION**

To prevent damage to the fuel system:

- Use only genuine Diesel fuel. Low-quality fuel can clog (caulk) the nozzle.
- Drain water from the fuel filter when the water-in-fuel warning lamp comes on.
- Keep the fuel filter replacement schedule.
- Prevent introduction of any foreign material during disassembly and assembly.

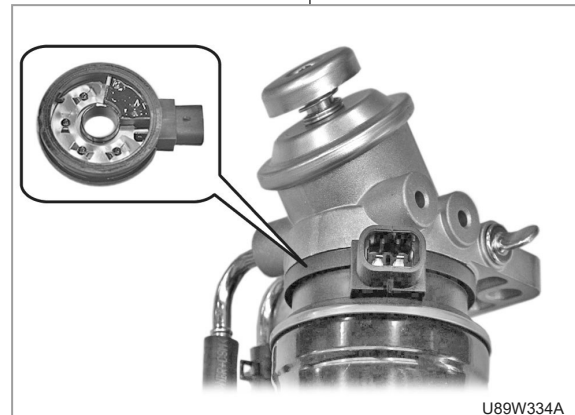
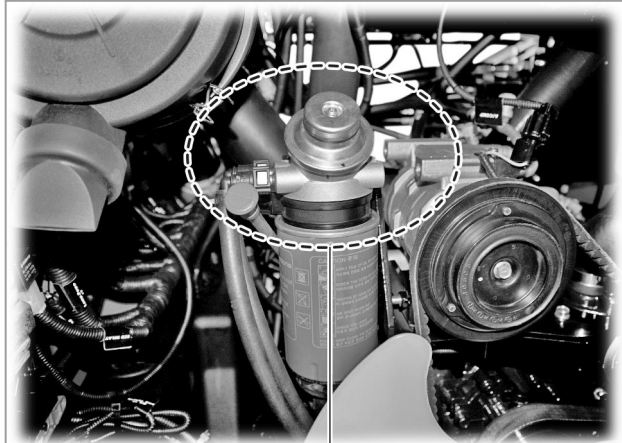
**3.5.8 FUEL HEATER AND FUEL COOLER****FUEL HEATER**

LF1W219A

The fuel heater is installed between the priming pump and filter body of the fuel filter. Diesel fuel contains paraffin, so it tends to solidify in a cold weather. In this case, fuel can block fuel passages, resulting in difficulty to start the engine or engine stall.

To prevent this, the filter is equipped with the heater which is operated to melt paraffin in fuel at temperatures below freezing.

When the bimetal in the heater reaches specified temperature, it is connected to the internal circuit and receives power from the external heater relay.

When the bimetal in the heater reaches specified temperature, it is connected to the internal circuit and receives power from the external heater relay.

When the switch contact is closed under sub-zero temperatures, the relay is turned ON to operate the heater which then heats fuel.

**► RANGE OF BIMETAL OPERATION TEMP.**

- ON :  $-3^{\circ}\text{C} \pm 4^{\circ}\text{C}$
- OFF :  $17^{\circ}\text{C} \pm 4^{\circ}\text{C}$

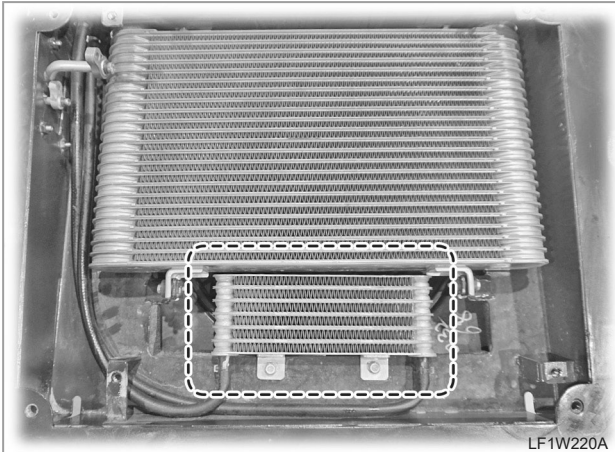
**FUEL COOLER**

In the CRDI (Common Rail Direct Injection) engine, the temperature of returning fuel is increased high due to high pressure and multiple injection of the injectors.

If the temperature of diesel fuel becomes excessively high, its lubrication film breaks and its elements are transmuted. Then, some components using fuel as lubricant, such as the high-pressure pump, can be damaged easily.

Therefore, fuel returned from the injector to the high-pressure fuel pump through the return pipe is passed through the fuel cooler to be cooled before returning back to the fuel tank.

**► SPECIFICATION**

- Air flow: 8 m/s
- Fuel flow: 2.6 LPM
- Fuel inlet temperature: 95°C (203°F)
- Fuel capacity: Approx. 0.15 L

**3.6 ACCELERATION SYSTEM**

When depressing the accelerator pedal (1) or moving the engine throttle dial (2) to select a high speed, detects the amount of movement of the acceleration position sensor and sends this information to the ECU which then permits combustion in the chamber to increase the engine RPM and power.

**ACCELERATION POSITION SENSOR**

HAND

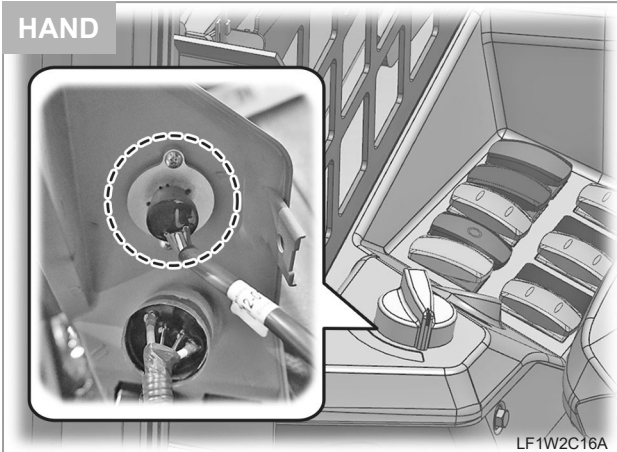

FOOT



**ENGINE SIGNAL STRUCTURE**

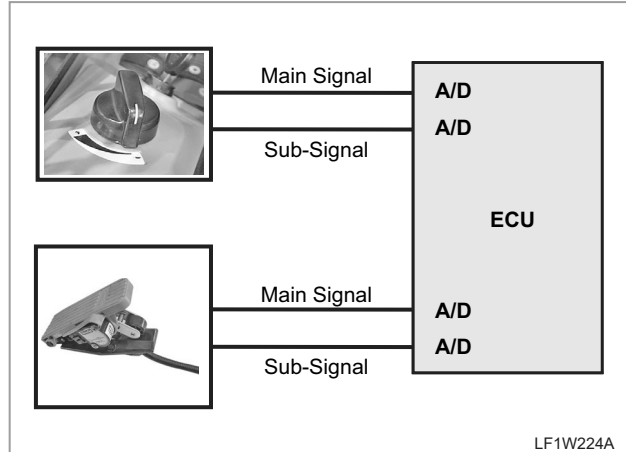

The APS (Acceleration Position Sensor) detects the amount of accelerator pedal depression and engine throttle dial moving distance. It sends information regarding to displacement of the pedal and lever to the ECU. The engine ECU determines the fuel injection amount and injection timing based on the information from this sensor. This sensor consists of two potentiometers each for the hand throttle lever and accelerator pedal. Two separate sensors are integrated into this one sensor to complement for each other. The sensor 1 plays a major role in determination of the fuel injection amount and injection timing while the sensor 2 detects any defective signal from the sensor 1.

Therefore, safe engine operation is guaranteed through this dual tracking signal structure. In a normal condition, the ECU receives normal main and auxiliary signals. However, if any of these signals is faulty (signal value difference more 15%), the ECU does not change the engine operating condition but keeps the engine in this condition.

3.7 INTAKE & EXHAUST SYSTEM

3.7.1 OVERVIEW

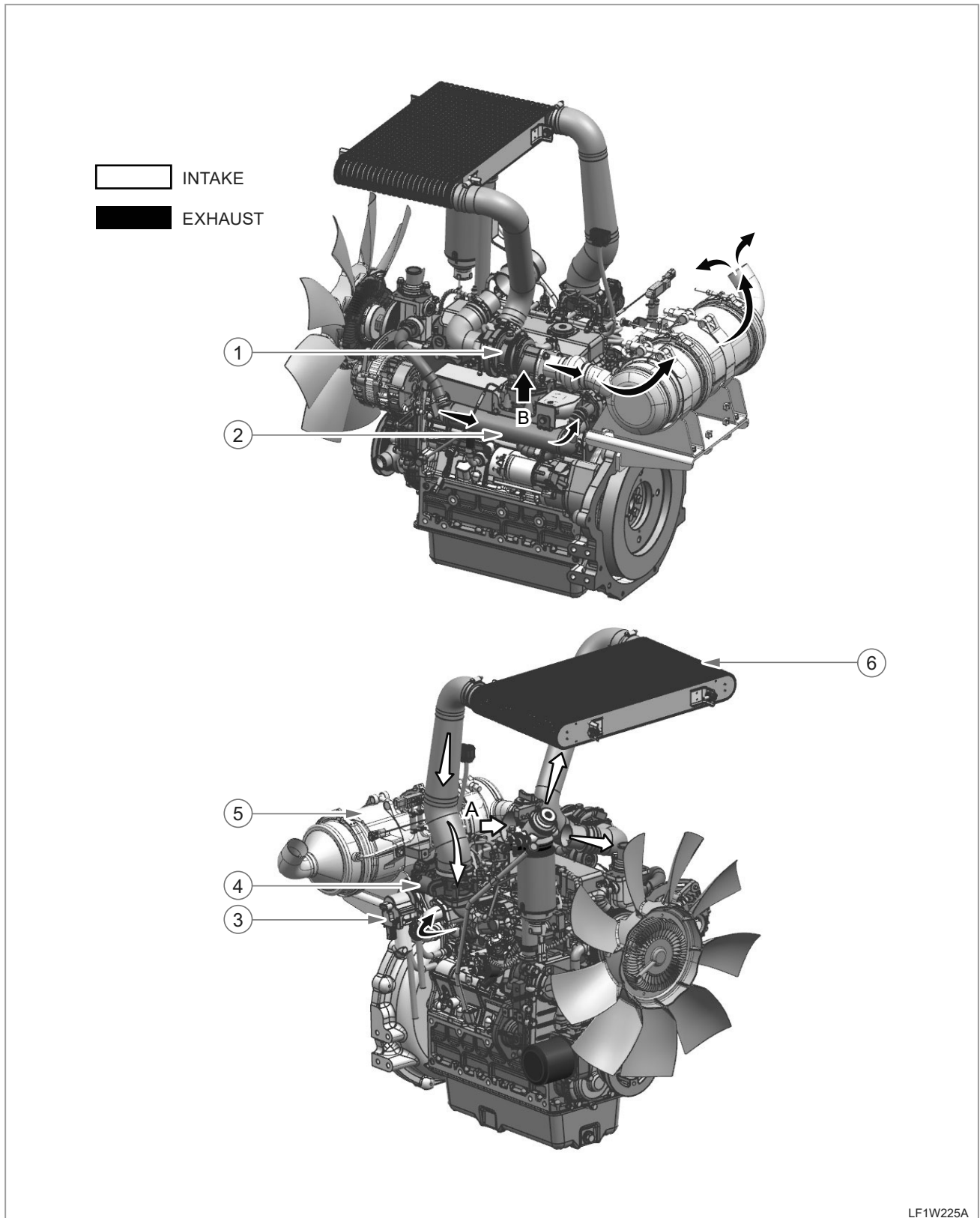

LF1W225A

- (1) Turbocharger
- (2) EGR cooler
- (3) EGR valve
- (4) Air control valve

- (5) CCRT (Catalyzed Continuously Regenerating Trap)
- (6) Inter cooler
- (A) From air cleaner
- (B) To CCRT (Catalyzed Continuously Regenerating Trap)

As fresh air is drawn in to the system through the air cleaner, it flows to the compressor wheel side of the turbocharger (1) through the suction pipe to go through the compression process. Then, it is supplied to the intercooler through the connecting pipe, cools to the specified temperature, and it flows to the intake manifold flange through the air control valve (4).

On the other side, exhaust gas discharged from the exhaust manifold enters the turbocharger to turn the turbine and it is discharged to the air through the CCRT (Catalyzed Continuously Regenerating Trap) (5). Its remainder is drawn into the EGR cooler (2) as illustrated.

This exhaust gas in the EGR cooler is moved to the passage in the cylinder head through the bellows, and it passes through the EGR valve (3) on the other side to enter the intake manifold flange through the connecting pipe. Finally, fresh air, which was compressed by the turbocharger, and exhaust gas are mixed together, flowing into the cylinder of the engine.

### ► INTAKE

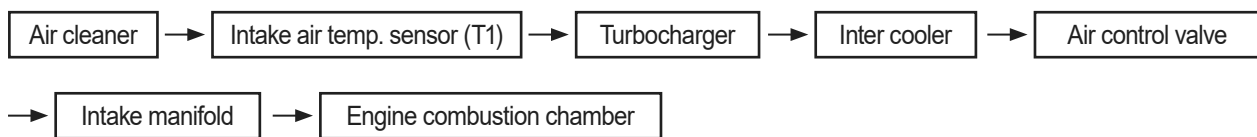

### ► EXHAUST

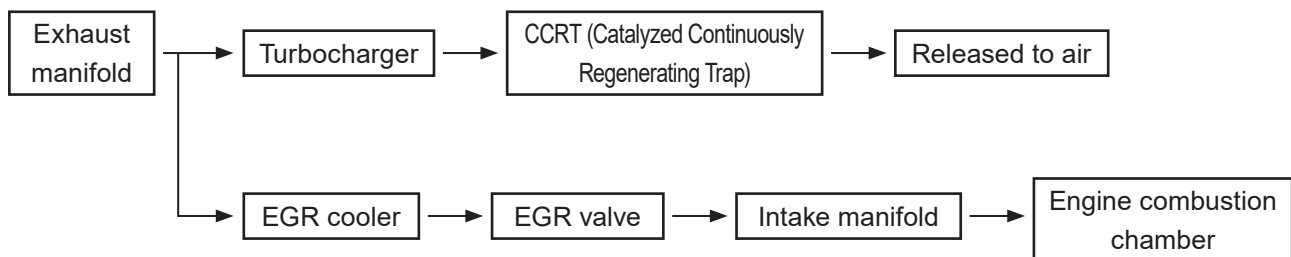



3.7.2 EGR COOLER

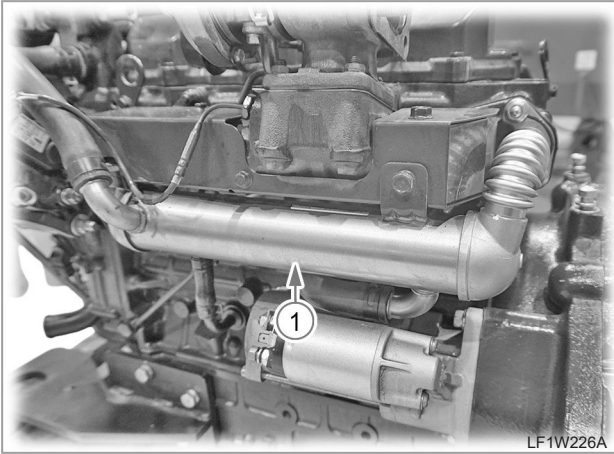

- Normally, when the combustion temperature in the combustion chamber is high, a lot of NOx (Nitrogen Oxide) is generated. To decrease this amount, some of exhaust gas is recirculated to decrease the oxygen density so the combustion temperature, and this method is called EGR (Exhaust Gas Recirculation). This EGR type supplies some of exhaust gas to the cylinder so the amount of intake air and fuel consumption are decreased, resulting in improvement of fuel efficiency.
- The EGR cooler (2) is a pipe type cooler as illustrated and is connected to the coolant flange and cylinder block. It is also connected to the exhaust manifold to flow coolant along the duct line of exhaust gas from the exhaust manifold through the cylinder head passage to the EGR valve to decrease the temperature of exhaust gas.

3.7.3 EGR VALVE

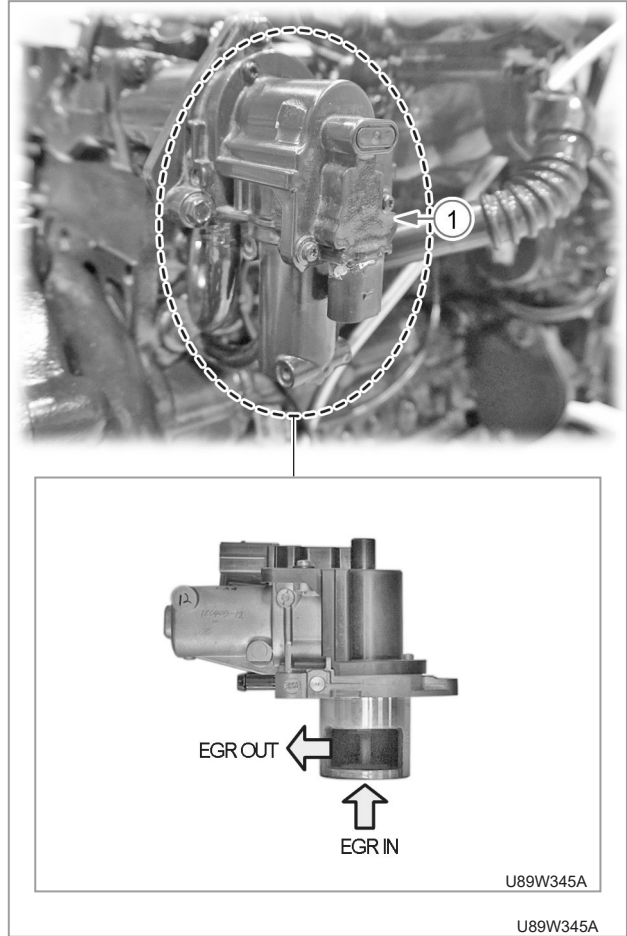

The EGR valve (1) supplies exhaust gas to the cylinder so the amount of recirculation intake air and fuel consumption are decreased, resulting in improvement of fuel efficiency. The EGR valve adjust the amount of exhaust gas supplied to the cylinder. It supplies a proper amount of exhaust gas through control of the ECU based on signals from the position sensor.

**CHARACTERISTICS**

- Enhanced responsiveness and accuracy by control from engine ECU: Solenoid in EGR valve activated by receiving signal directly from engine ECU
- Feedback function added : Feedback for exact position of EGR valve to ECU
- Chattering elimination and durability enhancement : Reinforced with 2 valve seats
- EGR valve cleaning : Chattering with valve seat and solenoid in housing to remove foreign materials

SAFETY FIRST

ENGINE

DRIVING & CHASSIS

HYDRAULIC SYSTEM

ELECTRIC SYSTEM

CABIN

INDEX

EGR SYSTEM DIAGRAM

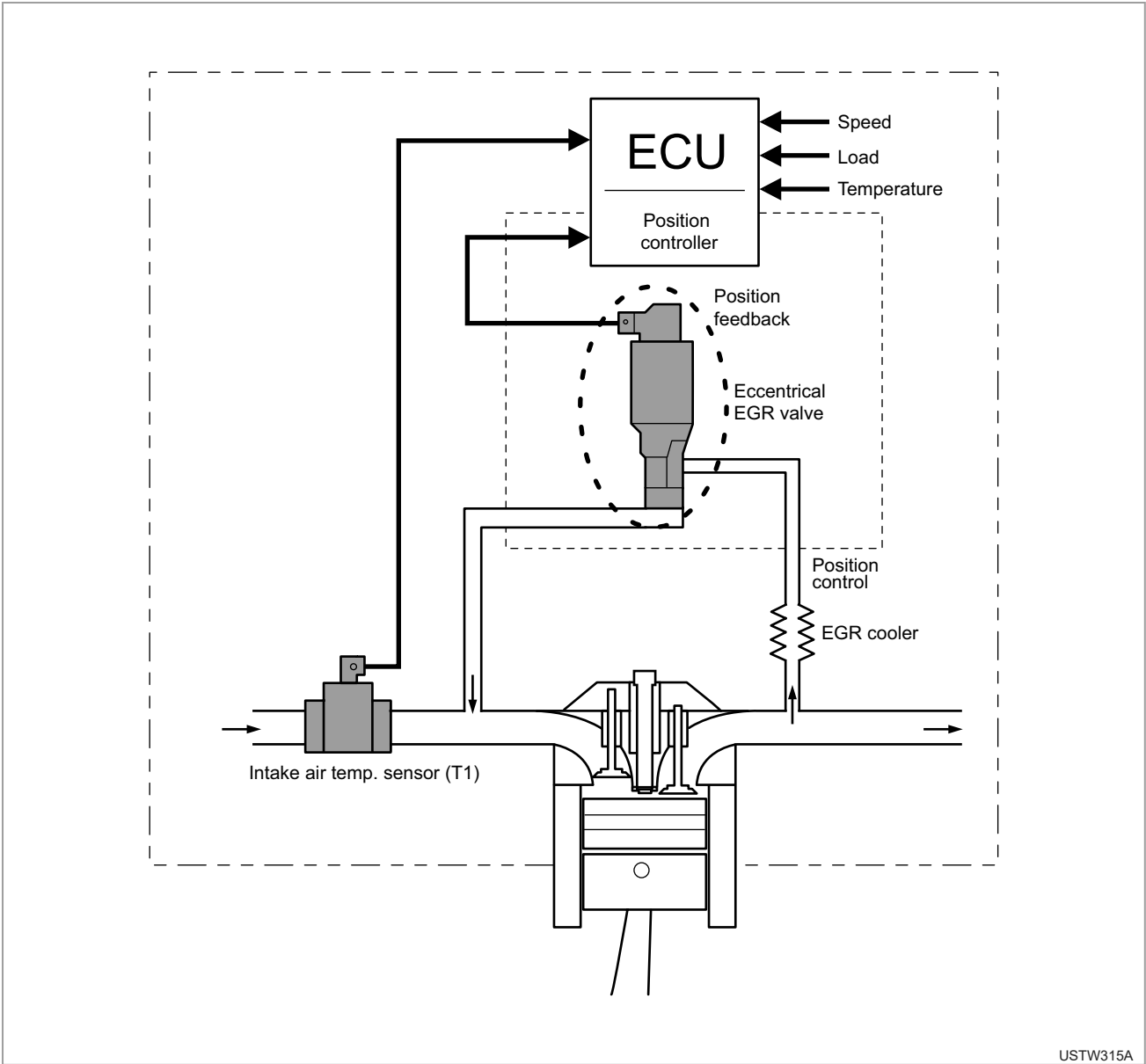

USTW315A

## 3.7.4 AIR CONTROL VALVE

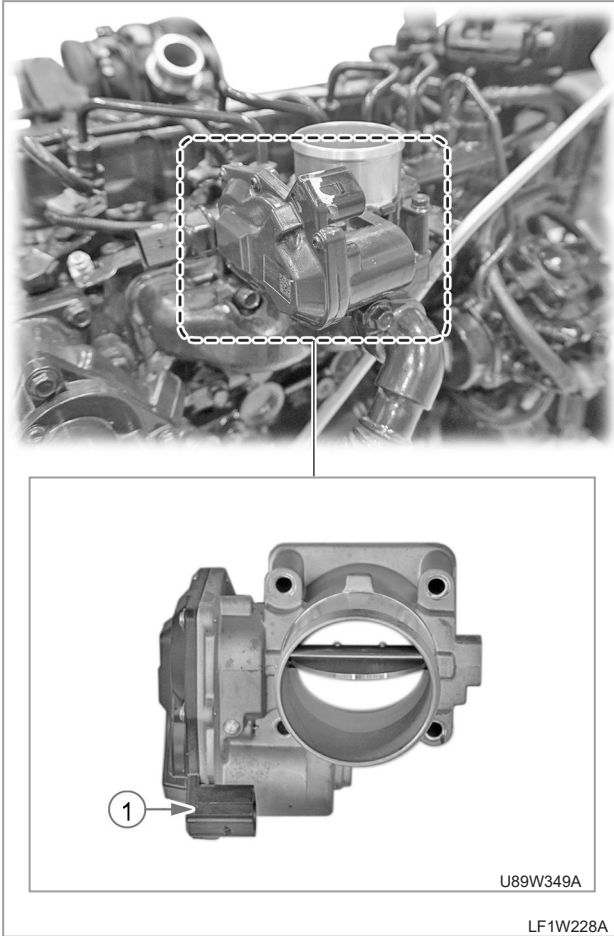

The air control valve is installed right before the intake manifold flange in order to control the amount of air before the air is drawn into the intake manifold through the turbocharger and intercooler after it is sucked through the air cleaner.

The inlet of the air control valve is equipped with a fan(throttle valve) to control the amount of intake air. This fan opens and closes according to the operation of the accelerator pedal to adjust the amount of air supplied into the cylinder.

Also, the air control valve has the throttle position sensor (1). This sensor detects the opening angle of the fan and sends this information to the ECU which then determines and controls the amount of injected fuel according to this value.

► **Air control valve characteristics**

- Prevention of dieseling and engine vibration by cutting off intake air with engine stopped
- Intake air amount control synchronized with CCRT system
- Effective EGR control synchronized with EGR system



**REMARKS**

- When the ignition switch is turned to the OFF position, the throttle valve is completely closed and the output voltage (5 V) is activated for approx. 1.2 seconds.

## 3.7.5 CCRT (CATALYZED CONTINUOUSLY REGENERATING TRAP)

## SYSTEM OVERVIEW

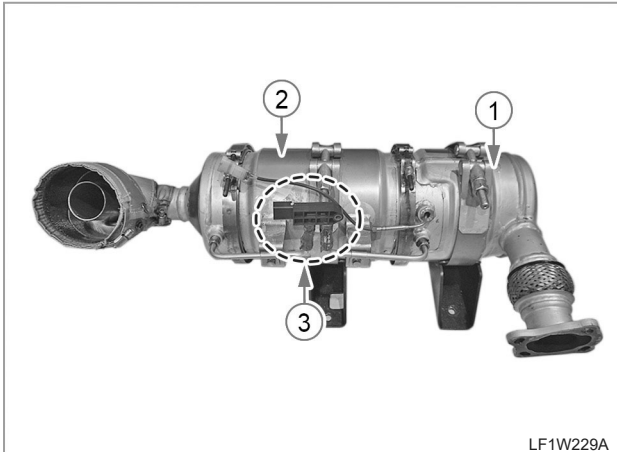

- (1) DOC (Diesel Oxidation Catalyst)
- (2) DPF (Diesel Particulate Filter)
- (3) Differential pressure sensor

The conventional DOC (Diesel Oxidation Catalyst) equipped in a diesel engine features high purification performance for HC and CO but low reduction rate of PMs. To enhance the performance, the conventional DOC has been combined with the DPF. The DOC discharges harmless CO<sub>2</sub> and H<sub>2</sub>O through oxidation of CO and HC while the DPF regenerates collected PMs (Particulate Materials). This system is called CCRT (Catalyzed Continuously Regenerating Trap).

Sulfur in diesel fuel combines with oxygen gas during combustion, promoting creation of PMs.

If an excessive amount of PMs is accumulated in the DPF (Diesel Particulate Filter), pressure difference between the front and rear sections of the DPF is detected by the differential pressure sensor (3), resulting in activation of regeneration process.

PMs are naturally combusted when the temperature of exhaust gas is high or there is a sufficient amount of NO<sub>x</sub> (Nitrogen Oxides).

Therefore, if regeneration is necessary, the ECU automatically controls the temperature of exhaust gas to activate the regeneration process. Alternatively, the driver can press the regeneration button until the corresponding indicator on the instrument cluster comes ON.

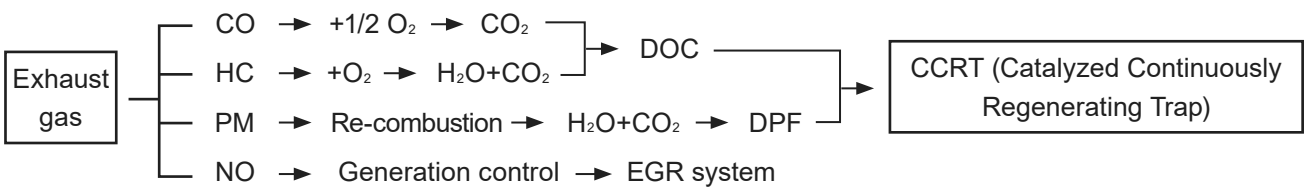

**SYSTEM OPERATING PRINCIPLE**

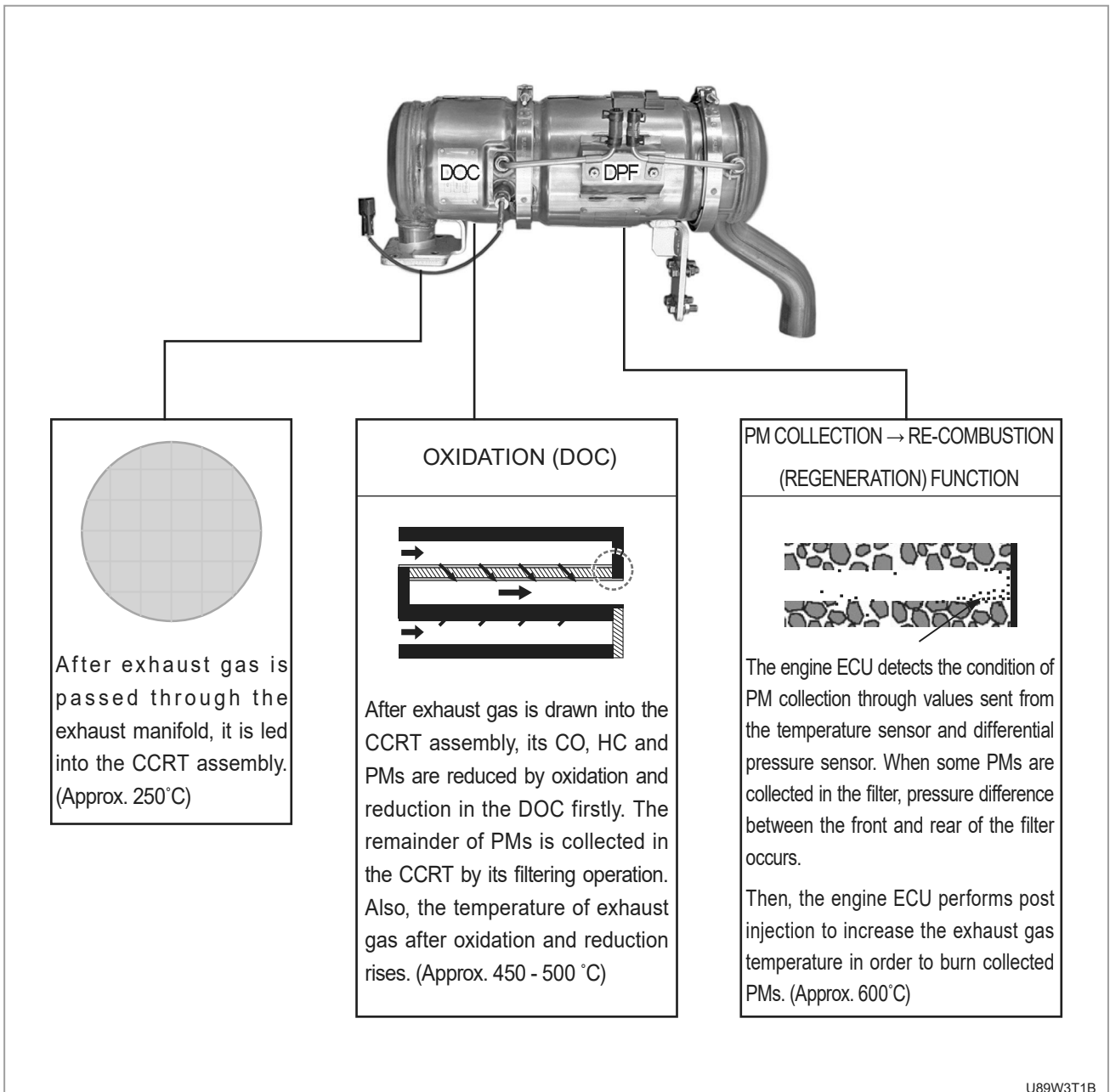

**PM REGENERATION OF DPF**

The DPF is equipped with the differential pressure sensor to detect the pressure at the inlet and outlet of the CCRT. The amount of PMs (Particulate Materials) in the filter of the CCRT is calculated based on the exhaust gas temperature, intake air temperature, booster pressure, etc.

When the weight of PMs in the filter becomes 21.1 g or higher, regenerating process is activated. The ECU commands post injection to increase the temperature in the CCRT up to 600°C during regeneration.

► **SPECIFIED PM AMOUNT NOT DETECTED: THE DPF PERFORMS ONLY ITS FILTERING FUNCTION**

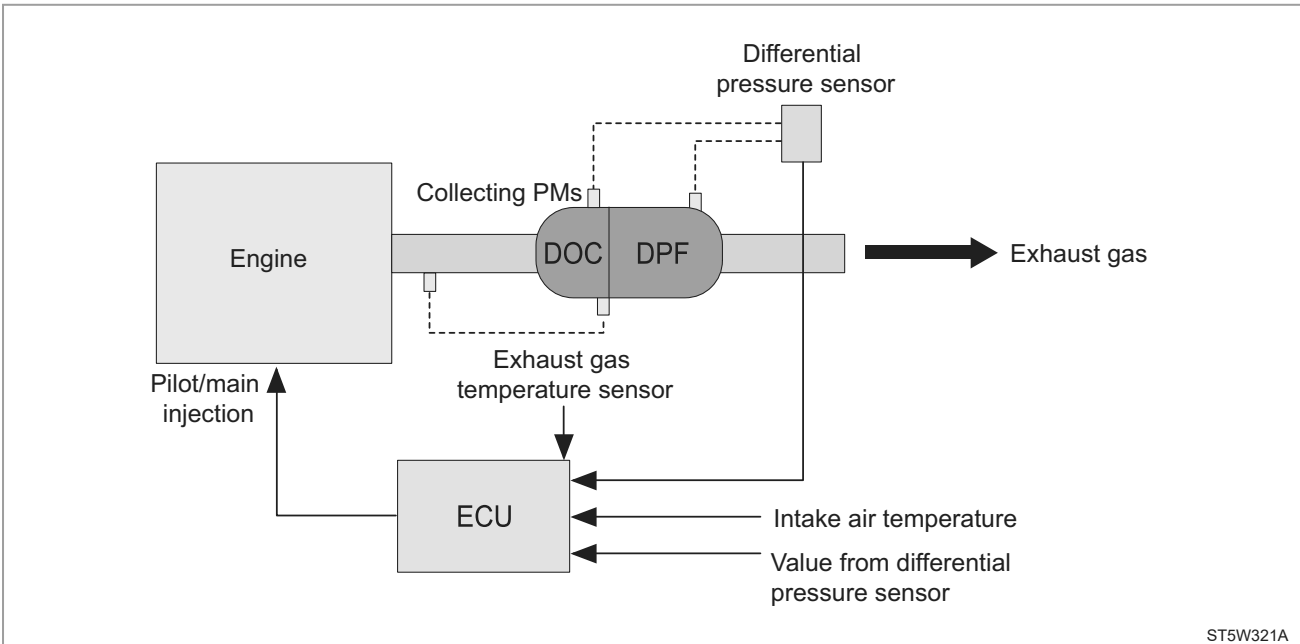

► **SPECIFIED PM AMOUNT DETECTED: THE ECU COMMANDS THE INJECTORS TO POST-INJECT FUEL IN ORDER TO INCREASE THE EXHAUST GAS TEMPERATURE FOR REGENERATION (RE-COMBUSTION).**

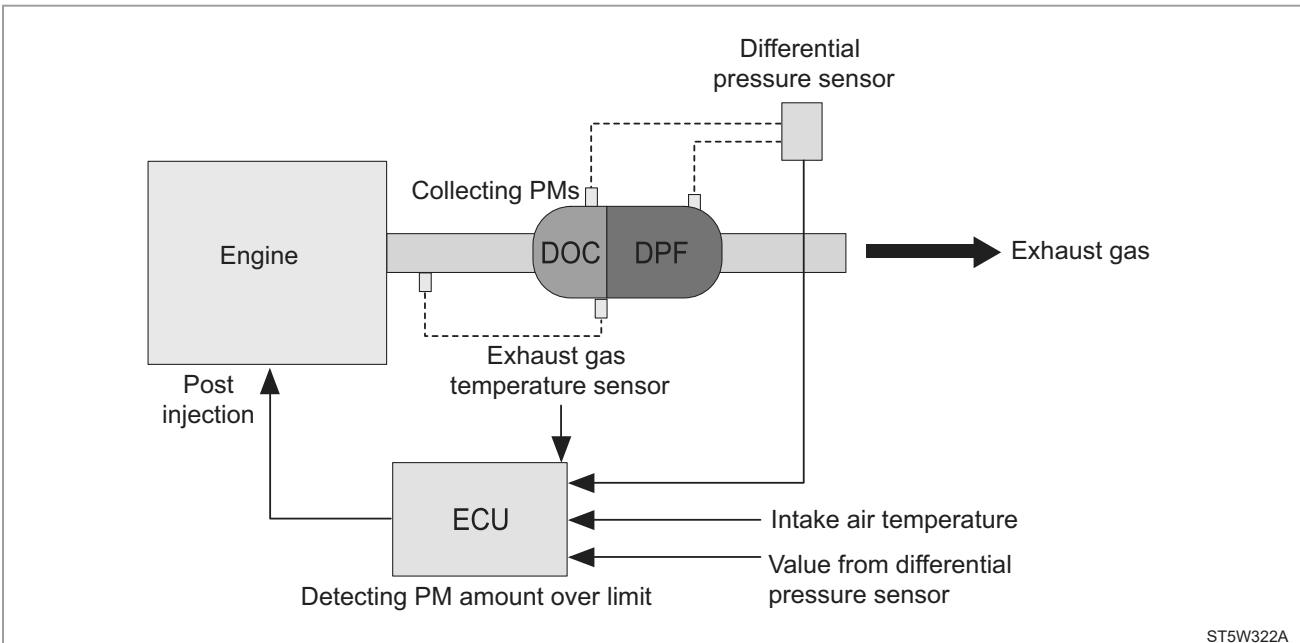

SAFETY FIRST

ENGINE

DRIVING & CHASSIS

HYDRAULIC SYSTEM

ELECTRIC SYSTEM

CABIN

INDEX

**CAUTION**

**PRECAUTIONS FOR MAINTENANCE OF CATALYTIC FILTER**

- Make sure to use the genuine fuel.
- Keep the engine oil change schedule.
- Check and service the engine oil amount frequently.
- Avoid unnecessary idling of the engine.
- Never stop the engine during driving.
- Never place the shift lever in the neutral position on a downhill.
- Do not use any kind of additive for engine oil and fuel.
- Avoid prolonged driving with the warning lamp illuminated.
- Make sure that any flammable material, such as dry grass or paper, gets to the catalytic filter while parked.

**REGENERATION STRATEGY**

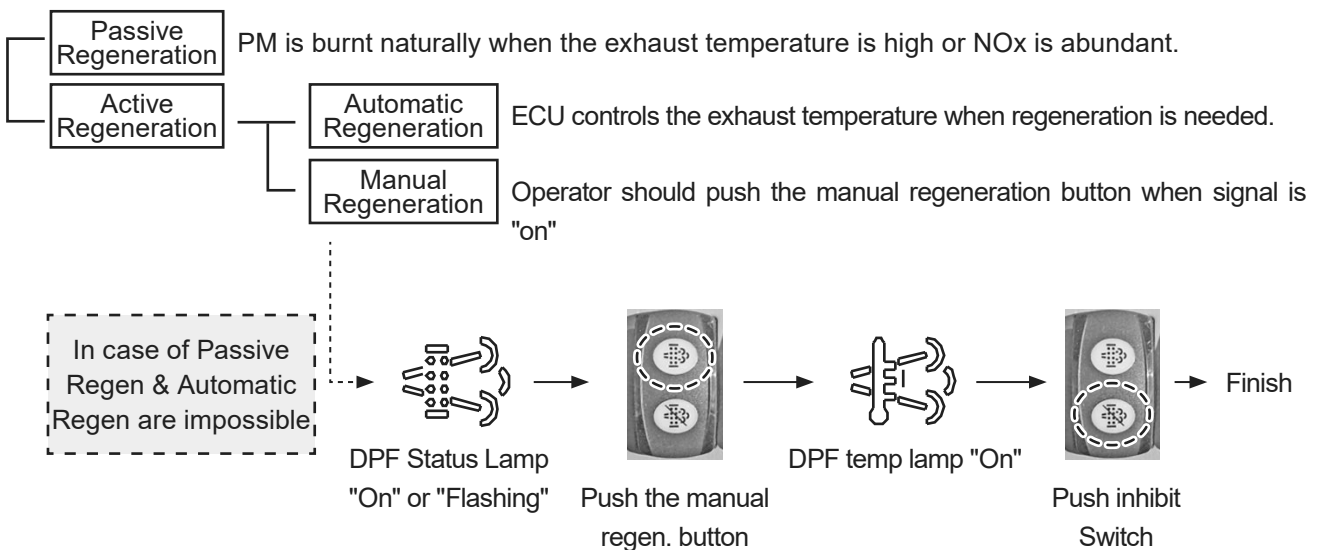

\* Ash Service Interval: 3000 Hours

## SOOT LOADING &amp; WARNING LAMP

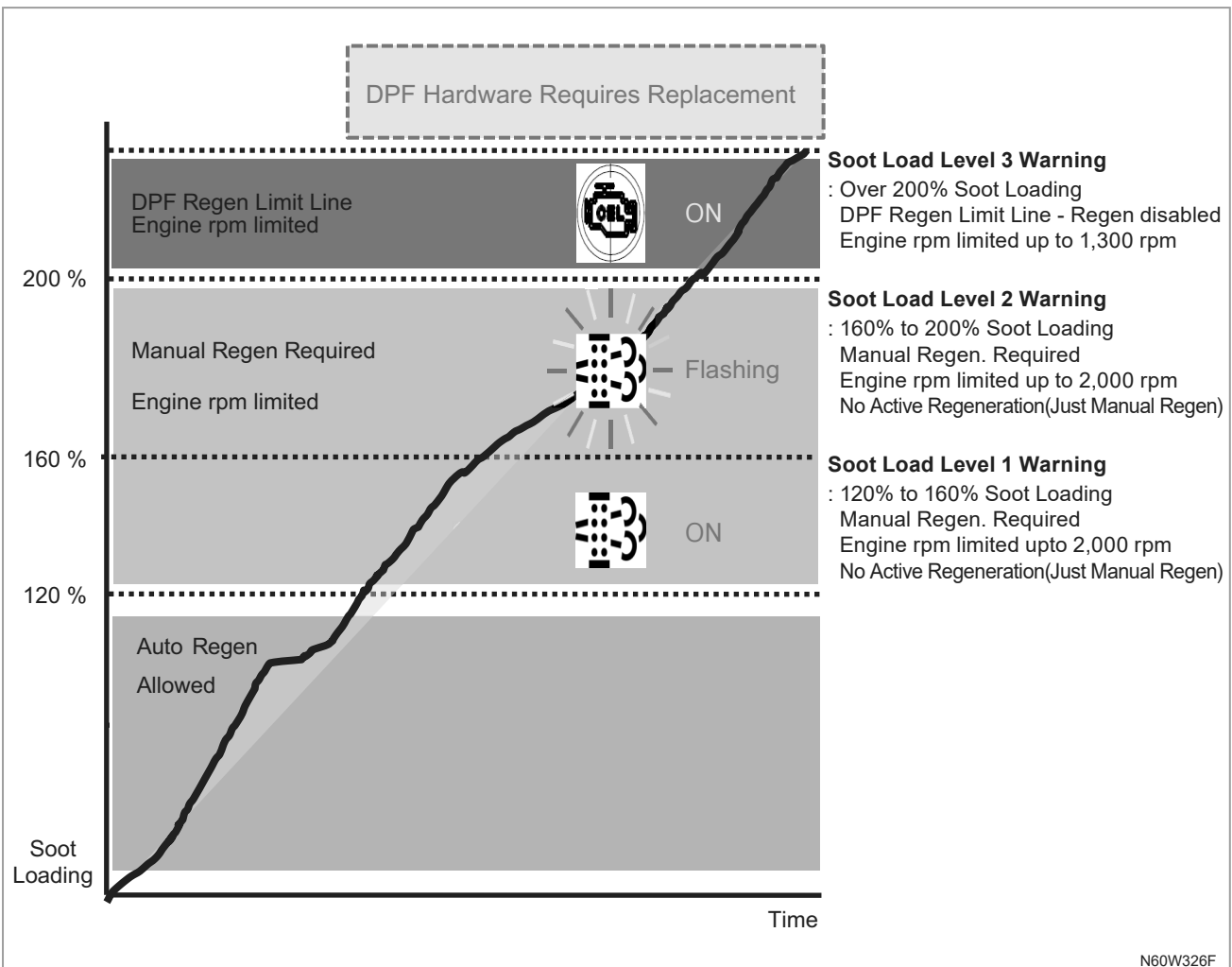

## REMARKS

- Both the manual and automatic regeneration processes cannot be performed under the level 3 warning condition (CEL lamp illuminated).
- If the DPF warning lamp comes on, the automatic regeneration process is disabled. Perform the manual regeneration process in this case.
- Method of manual regeneration activation
  - Park the tractor on firm level ground.
  - Parking brake switch ON (Apply the parking brake)
  - Foot/hand pedal angle 5% or less (Idle condition)
  - Press the regeneration button for approx. 2 seconds
- If any one of the above conditions is not satisfied during regeneration, the regeneration process is canceled.
- In manual regeneration, the operation is impossible and regenerate the following procedure.
  - 1st: Before Mode: 700 sec. at 1,500 rpm
  - 2nd: Regen Mode: 1,500 sec. at 2,600 rpm
  - 3rd: After Mode: 180 sec. at 1,600 rpm



3.7.6 TURBO CHARGER

**SYSTEM OVERVIEW**

The turbocharger is equipped with the turbine and compressor at a different angle at each end of one shaft. The compressor housing is connected to the intake manifold while the turbine housing is connected to the exhaust manifold. When the turbine starts to rotate by pressure of exhaust gas, the impeller on the intake side rotates as well. Then, air around the center of the impeller is applied with centrifugal force, accelerated outwards, and is drawn into the intake manifold through the intake connecting pipe. As the passage is large in volume, kinetic energy of supplied air is converted to pressure energy and this energy is supplied to the cylinder for superior volume efficiency. Also, exhaust efficiency is enhanced by rotation of the exhaust turbine.

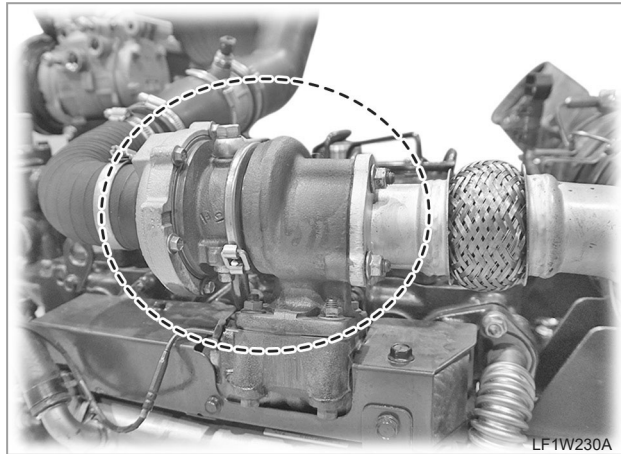

The turbocharger is installed between the exhaust manifold and intake manifold and it is driven by exhaust gas.

Its wheel on the turbine side is rotated at a high speed by exhaust gas while the compressor wheel on the other side is rotated by the connecting shaft. As fresh air is drawn through the air cleaner, it is compressed by the compressor wheel of the turbocharger under high pressure, higher than barometric pressure, and it flows to the intake valve.

The bearing in the turbocharger is lubricated by the engine oil from the engine cylinder block.

**TURBOCHARGER STRUCTURE**

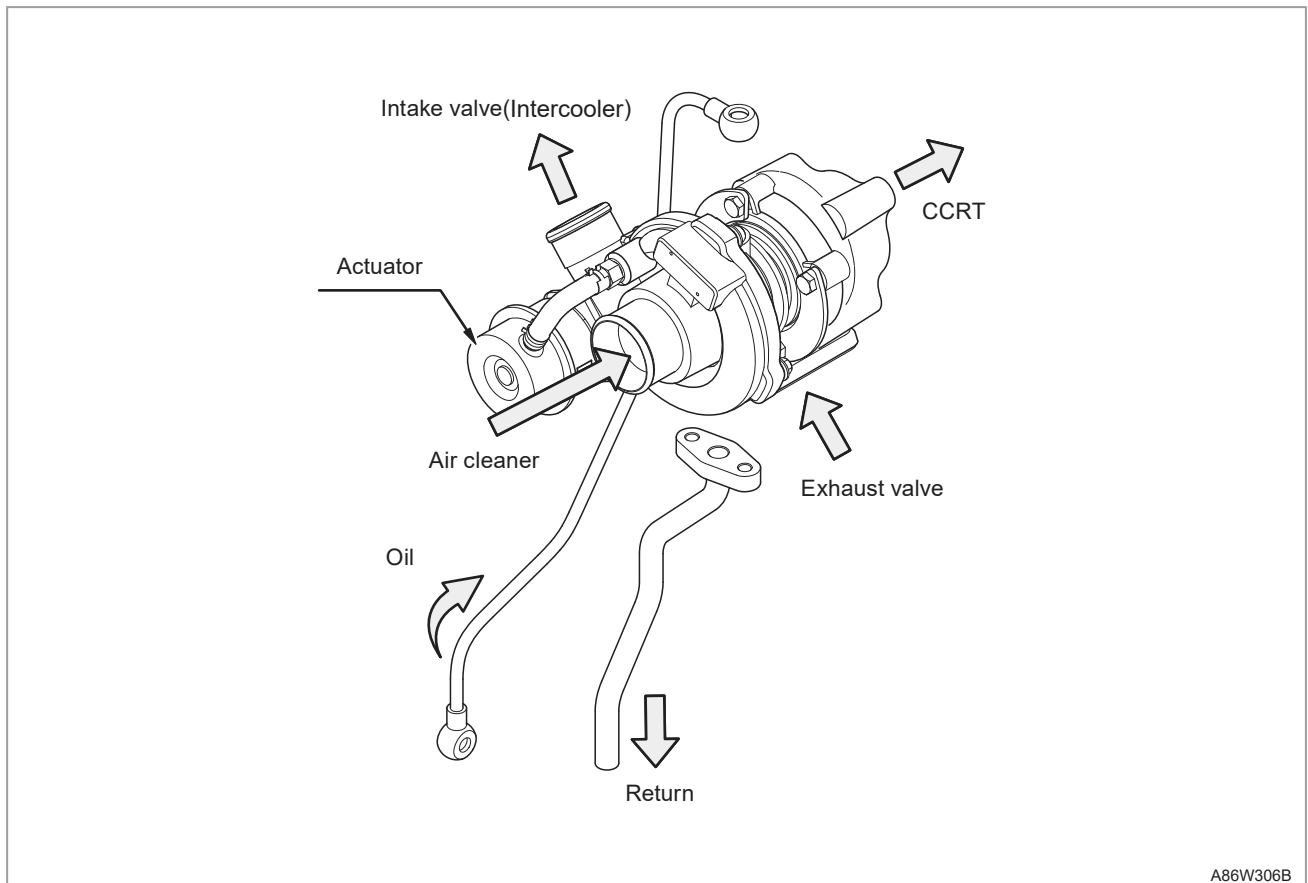

A86W306B

## 3.8 SENSOR

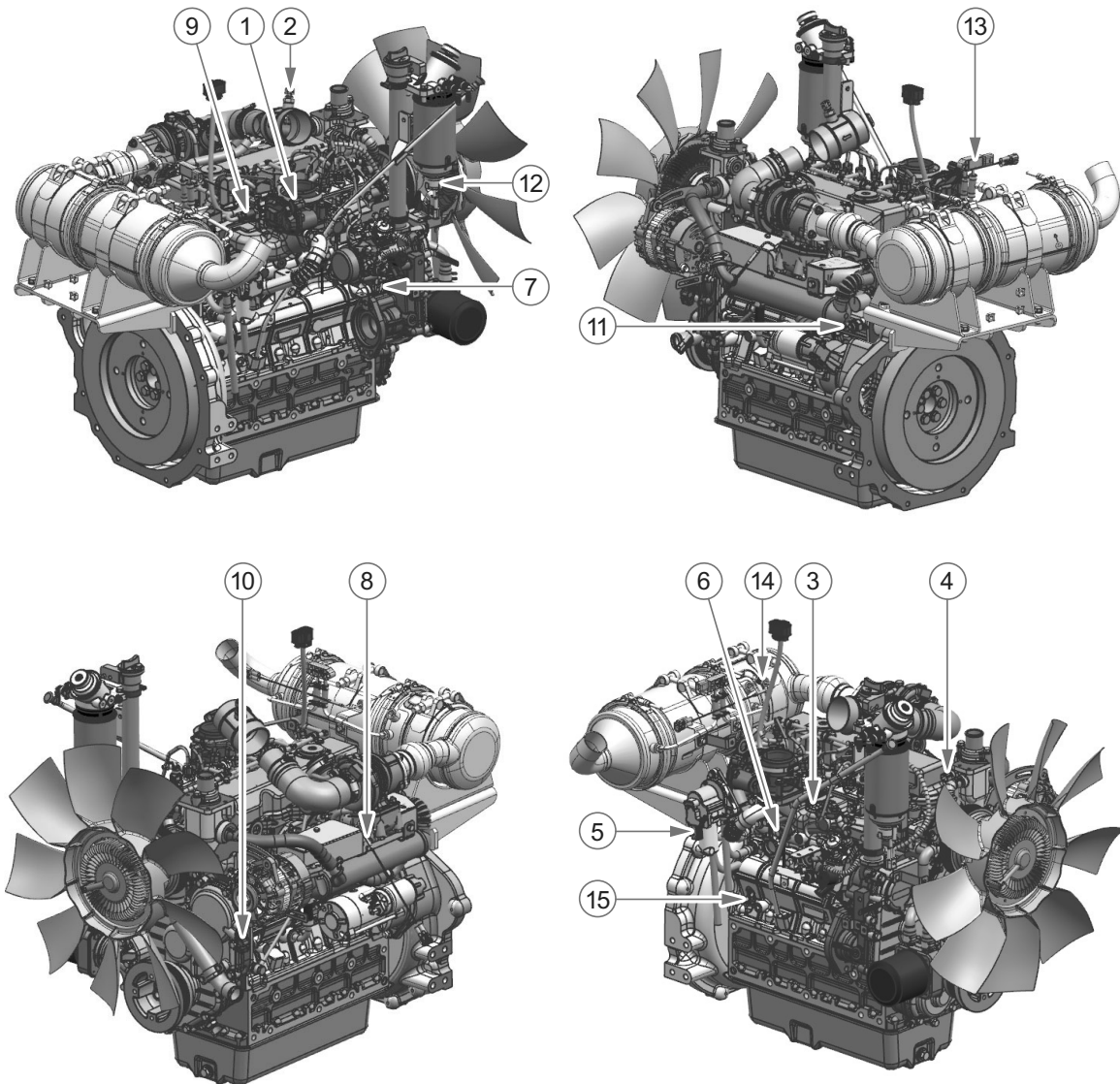

LF1W231A

- |   |                                   |
|---|-----------------------------------|
| (1) ACV( Air Control Valve)                 | (9) Rail pressure sensor          |
| (2) Intake air temp. sensor                 | (10) Cam position sensor          |
| (3) Air temp. & pressure sensor             | (11) Oil pressure switch          |
| (4) Water temp sensor                       | (12) WIF(Water In Fuel) sensor    |
| (5) EGR valve                               | (13) Differential pressure sensor |
| (6) Knock sensor (1 for 3 Cyl, 2 for 4 Cyl) | (14) Exhaust temp sensor(RR)      |
| (7) Fuel temp. sensor                       | (15) Crank shaft wheel sensor     |
| (8) Exhaust temp. sensor(FRT)               |                                   |

**SENSOR AND ACTUATOR COMPONENTS**

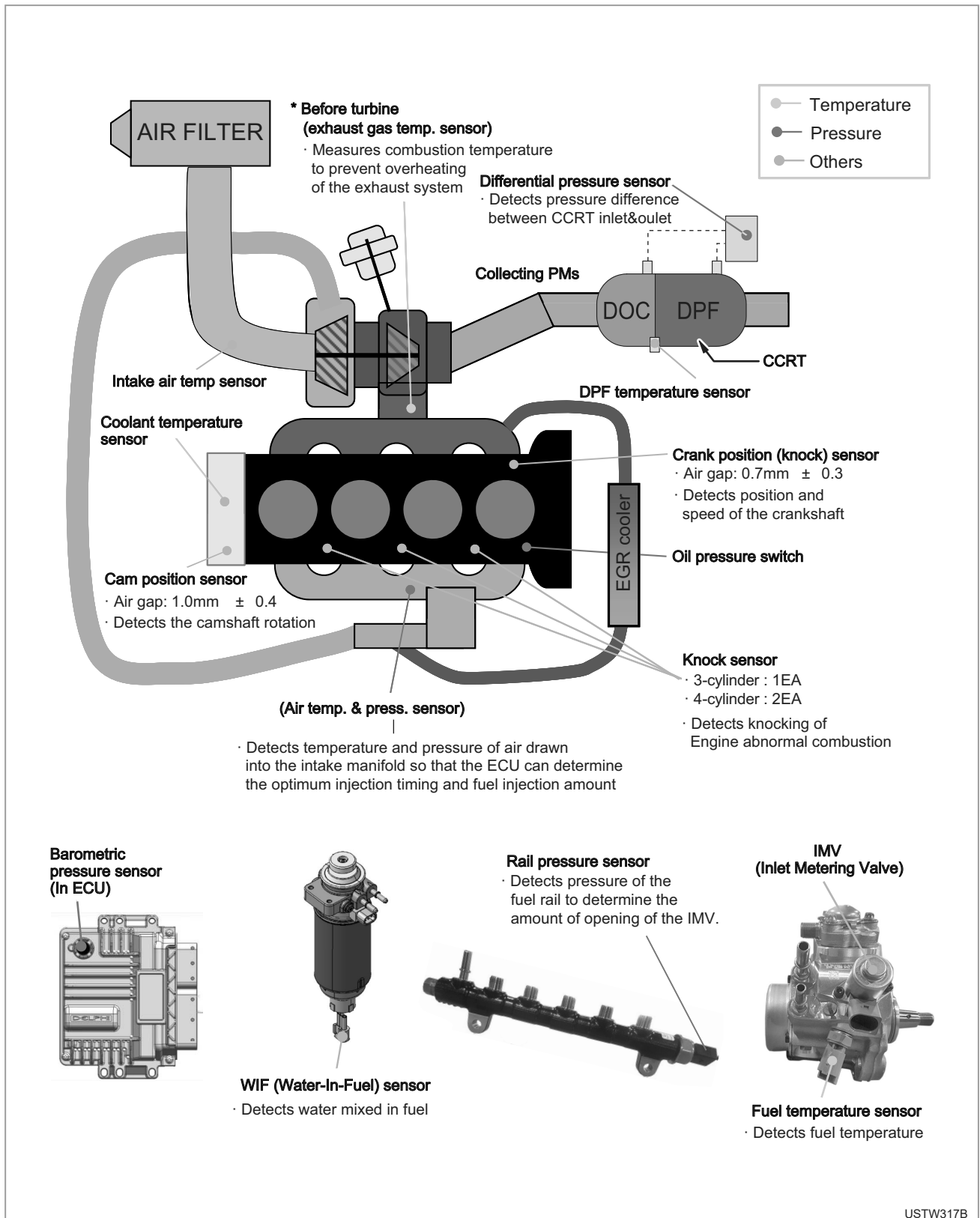

**INTAKE AIR TEMPERATURE SENSOR (T1) (2)**

The intake air temp. sensor is installed on the connection of the suction hose to detect temperature air flow. This information is used for determination of fuel injection amount as well as feedback control for EGR (Exhaust Gas Recirculation).

**AIR TEMP. & PRESSURE SENSOR (3)**

This sensor is installed on the intake manifold and its information is used as correction information for adjustment of the fuel amount, injection timing and fuel amount control at starting.

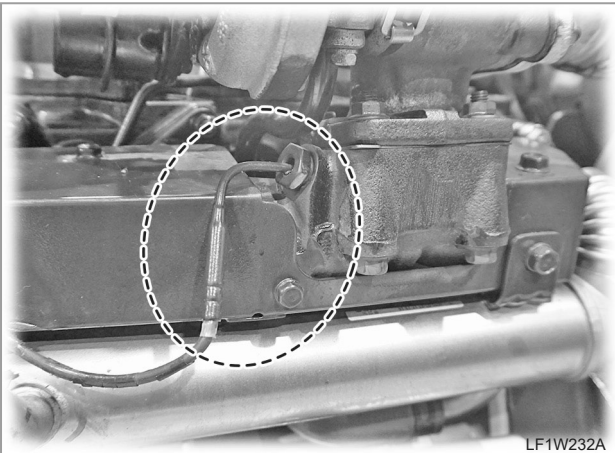
**FRONT EXHAUST GAS TEMPERATURE SENSOR (8)**

LF1W232A

It is installed to the back of the exhaust manifold to measure the combustion temperature in order to prevent overheating of the exhaust system.

If the system is overheated, the combustion temperature is decreased by the EGR control.

**DIFFERENTIAL PRESSURE SENSOR (13)**

ST5W344A

This sensor is to measure the pressure difference between the inlet and outlet of the CCRT.

(If the pressure difference between the inlet and outlet is over the specification due to collected PMs, post-injection is performed to regenerate PMs forcibly.)

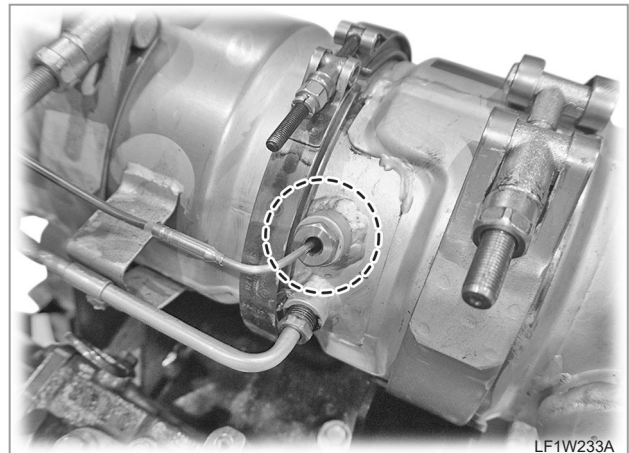
**REAR EXHAUST GAS TEMPERATURE SENSOR (14)**

LF1W233A

It is installed to the rear section of the DOC to determine overheating condition of the CCRT and fuel amount of the post-injection process.

The fuel amount for the post-injection process is adjusted by the exhaust gas temperature detected by this sensor. If the temperature is below 600°C, the fuel amount is increased to increase the regeneration temperature. If the temperature is over 600°C, the fuel amount is decreased or not adjusted.

When the engine is running in the low load range, the intake air amount is also adjusted to increase the regeneration temperature.

This process is used to add more fuel and reduce intake air amount simultaneously within the set control logic range in order to increase the combustion temperature during the post-injection process.

3.8.1 SENSORS AS INPUT/OUTPUT FOR ECU

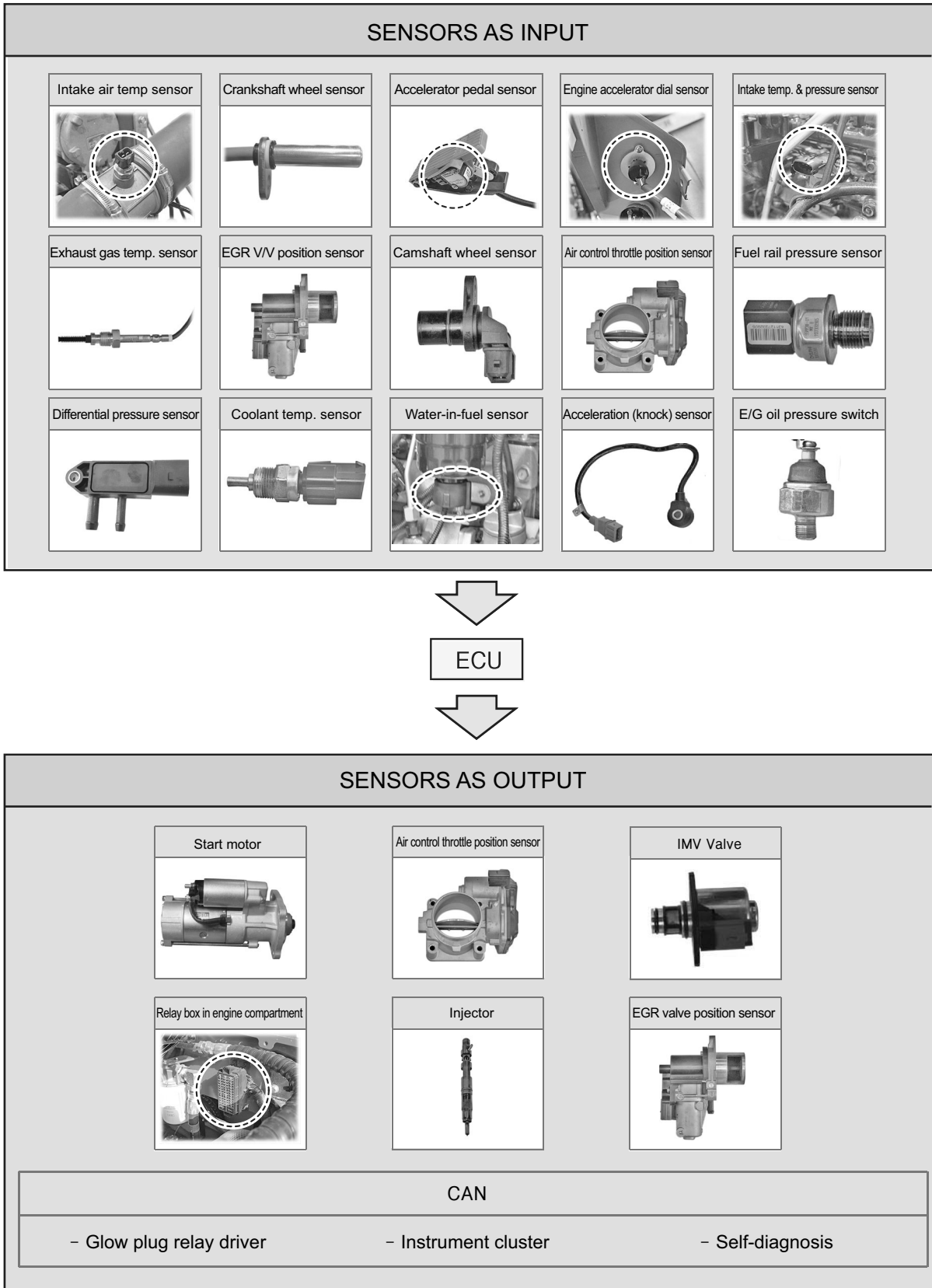

## 4. TROUBLESHOOTING

SYMPTOM	CAUSES	REMEDY
Engine Does Not Start	<ul style="list-style-type: none"> <li>No fuel</li> <li>Air in fuel system</li> <li>Water in fuel system</li> <li>Clogged fuel pipe</li> <li>Clogged fuel filter</li> <li>Excessively high viscosity of fuel or engine oil at low temperature</li> <li>Fuel with low cetane number</li> <li>Fuel leak due to loose injection pipe mounting nut</li> <li>Incorrect injection timing</li> <li>Defective fuel injection pump</li> <li>Defective fuel transfer pump</li> <li>Seizure of transfer pump, defective piston, cylinder bore or bearing</li> <li>Compression leak from cylinder</li> <li>Improper valve timing</li> <li>Worn piston ring and bore</li> <li>Excessive valve clearance</li> </ul>	Add fuel Bleed air Change fuel and repair or flush fuel system Clean Clean or replace Use the specified fuel or engine oil Use the specified fuel Tighten nut Adjust Repair or replace Repair or replace Repair or replace Replace head gasket, tighten cylinder head screws, glow plug and nozzle holder Correct or replace timing gear Repair or replace Adjust
Start motor Does Not Run	<ul style="list-style-type: none"> <li>Discharged battery</li> <li>Defective start motor</li> <li>Defective key switch</li> <li>Disconnected wiring</li> </ul>	Charge Repair or replace Repair or replace Connect
Engine Running is Not Smooth	<ul style="list-style-type: none"> <li>Clogged or dirty fuel filter</li> <li>Clogged Air cleaner</li> <li>Fuel leak due to loose injection pipe mounting nut</li> <li>Defective fuel injection pump</li> <li>Seized or clogged nozzle</li> <li>Clogged fuel overflow pipe</li> </ul>	Clean or replace Clean or replace Tighten nut Repair or replace Repair or replace Clean or replace
Either White or Blue Exhaust Smoke is Produced	<ul style="list-style-type: none"> <li>Excessive engine oil</li> <li>Worn piston ring and bore or seized piston ring</li> <li>Insufficient compression pressure</li> </ul>	Reduce to the specified level Repair or replace Adjust valve clearance
Either Black or Dark Gray Exhaust Smoke is Produced	<ul style="list-style-type: none"> <li>Overheat or overload</li> <li>Low grade fuel used</li> <li>Clogged fuel filter</li> <li>Clogged Air cleaner</li> </ul>	Reduce load Use the specified fuel Clean or replace Clean or replace
Insufficient Output	<ul style="list-style-type: none"> <li>Seized engine components</li> <li>Uneven fuel injection</li> <li>Insufficient nozzle injection</li> <li>Compression pressure leak</li> </ul>	Repair or replace Repair or replace the fuel injection pump Repair or replace the nozzle Replace cylinder head gasket, check tightness of cylinder head screws and nuts, glow plug and nozzle holder

<b>SYMPTOM</b>	<b>CAUSES</b>	<b>REMEDY</b>
Excessive Engine Oil Consumption	<ul style="list-style-type: none"> <li>• Aligned gaps of piston rings</li> <li>• Worn or seized oil ring</li> <li>• Worn piston ring groove</li> <li>• Worn valve stem and guide</li> <li>• Worn crankshaft bearings and crank pin bearings</li> </ul>	Change the ring gap direction Replace Replace piston Replace Replace
Water in Engine Oil	<ul style="list-style-type: none"> <li>• Defective cylinder head gasket</li> <li>• Cracked cylinder block or cylinder head</li> </ul>	Replace Replace
Low Oil Pressure	<ul style="list-style-type: none"> <li>• Insufficient engine oil</li> <li>• Clogged oil strainer</li> <li>• Clogged oil filter cartridge</li> <li>• Relief valve stuck with dirt</li> <li>• Weak or broken relief valve spring</li> <li>• Excessive oil clearance of crankshaft bearings</li> <li>• Excessive oil clearance of crank pin bearings</li> <li>• Excessive oil clearance of rocker arm bushings</li> <li>• Clogged oil passage</li> <li>• Improper type of oil</li> <li>• Defective oil pump</li> </ul>	Add Clean Replace Clean Replace Replace Replace Replace Clean Use the specified type of oil Repair or replace
High Oil Pressure	<ul style="list-style-type: none"> <li>• Improper type of oil</li> <li>• Defective relief valve</li> </ul>	Use the specified type of oil Replace
Engine Overheating	<ul style="list-style-type: none"> <li>• Insufficient engine oil</li> <li>• Damaged fan belt or improper tension</li> <li>• Insufficient coolant</li> <li>• Corroded radiator</li> <li>• Corroded coolant flow line</li> <li>• Defective radiator cap</li> <li>• Damaged coolant pipe</li> <li>• Defective thermostat</li> <li>• Defective coolant pipe</li> <li>• Overload running</li> <li>• Defective cylinder head gasket</li> <li>• Improper fuel used</li> </ul>	Add Replace or adjust Add Clean or replace Clean or replace Replace Replace Replace Replace Reduce load Replace Use the specified fuel
Coolant leakage	<ul style="list-style-type: none"> <li>• Damaged mechanical seal on water pump</li> </ul>	Replace water pump
Frequently Discharged Battery	<ul style="list-style-type: none"> <li>• Insufficient battery electrolyte</li> <li>• Fan belt slip</li> <li>• Disconnected wiring</li> <li>• Defective regulator or alternator</li> <li>• Defective battery</li> </ul>	Add distilled water and charge Adjust fan belt tension or replace it Connect Replace Replace

SAFETY FIRST

ENGINE

DRIVING & CHASSIS

HYDRAULIC SYSTEM

ELECTRIC SYSTEM

CABIN

INDEX

 REMARKS
**TURBOCHARGER TROUBLESHOOTING**

The chart below is given to assist in the correct diagnosis of turbocharger faults.

PROBLEMS	POSSIBLE CAUSES CODE NUMBERS
Not enough power	1,4,5,6,7,8,9,10,11,18,20,21,22,25,27,28,34,35,36
Black smoke	1,4,5,6,7,8,9,10,11,18,20,21,22,25,27,28,34,35,36
Blue smoke	1,2,4,7,8,9,17,19,20,21,22,30,31,32,34
High lubricating oil consumption	2,8,15,17,19,20,28,29,31,32,34
Too much lubricating oil at turbine end	2,7,8,17,19,20,22,28,30,31,32
Too much lubricating oil at compressor end	1,2,4,5,6,8,19,20,21,28,31,32
Not enough lubrication	8,12,14,15,16,23,24,29,32,33,37,38
Lubricating oil in exhaust manifold	2,7,17,18,19,20,22,28,31,32
Lubricating oil in intake manifold	1,2,4,5,6,8,10,11,17,18,19,20,21,28,32,34
Damaged compressor impeller	3,4,6,8,12,15,16,20,21,23,24,29,32,33,37,38
Damaged turbine rotor	7,8,12,13,14,15,16,18,20,22,23,24,25,27,29,32,33,37,38
Rotating assembly does not turn freely	3,6,7,8,12,13,14,15,16,18,20,21,22,23,24,29,32,33,37,38
Worn bearings, bearing bores, journals	6,7,8,12,13,14,15,16,23,24,29,33,37,38
Noisy turbocharger	1,3,4,5,6,7,8,9,10,11,12,13,14,15,16,18,20,21,22,23,24,29,32,33,34,37,38
Sludge or carbon deposit in bearing housing	2,11,13,14,15,17,18,24,29,33,37,38

- |   |  |  |
|---|--|--|
| 1. Element of air filter dirty  | 12. Delayed lubrication to turbocharger during engine starting | 25. Defective high pressure fuel pump                      |
| 2. Restricted crankcase breather  | 13. Insufficient lubrication                                   | 27. Valves burned  |
| 3. Element of air filter not fitted, improper sealing or loose connection to turbocharger | 14. Dirty engine oil   | 28. Worn piston rings                                      |
| 4. Internal distortion or restriction in pipe from air filter to turbocharger             | 15. Incorrect engine oil                                       | 29. Lubricating oil leakage from supply pipe               |
| 5. Damaged/restricted crossover pipe, turbocharger to intake manifold                     | 16. Restricted lubricating oil supply pipe                     | 30. Excessive preservation fluid (on initial engine start) |
| 6. Clogged air filter and turbocharger  | 17. Restricted lubricating oil drain pipe                      | 31. Excessive engine idle period                           |
| 7. Restriction in exhaust system  | 18. Turbine housing damaged or restricted                      | 32. Restriction in turbocharger bearing housing            |
| 8. Loose turbocharger or clamps/setscrews   | 19. Leakage from turbocharger seals                            | 33. Clogged oil filter                                     |
| 9. loose or cracked intake manifold or distorted flange                                   | 20. Worn turbocharger bearings                                 | 34. Air cleaner: Restricted, dirty element                 |
| 10. Cracked or loose exhaust manifold or distorted flange                                 | 21. Excessive dirt in compressor housing                       | 35. Waste-gate actuator faulty or damaged                  |
| 11. Restricted exhaust system   | 22. Excessive carbon behind turbine rotor                      | 36. Waste-gate valve not free                              |
|   | 23. Engine speed raised too rapidly at initial start           | 37. Engine stopped too soon from high load                 |
|   | 24. Insufficient engine idle period                            | 38. Insufficient lubricating oil                           |



5. MEASUREMENT AND ADJUSTMENT

5.1 FAN BELT

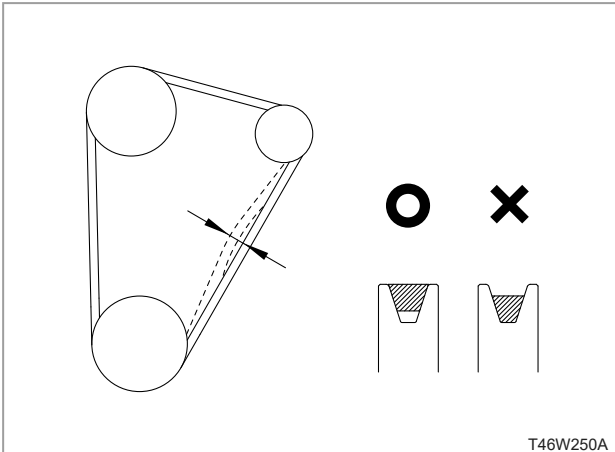

Measure the deflection by depressing the center of the belt between the fan drive pulley and the alternator pulley at 98 N (10 kgf, 22 lbs) of force.

If the deflection is out of the specified value, loosen the bolts and nuts and adjust the location of the alternator.

If the belt is damaged or worn (see figure), replace the belt.

**Fan belt deflection..... 7 ~ 9 mm  
(0.28 ~ 0.35 in.)**

5.2 PISTON COMPRESSION PRESSURE MEASUREMENT

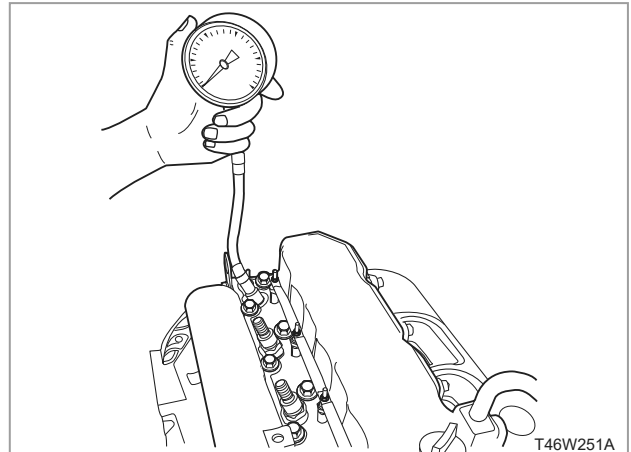

1. Run the engine until it is warmed up.
2. Stop the engine and remove the air cleaner, the muffler and all nozzle holders.
3. Connect a compression tester to the nozzle holder hole.
4. Pull the stop lever or close the fuel filter with the cock to cut the fuel and crank the engine with the starter motor for 5 to 10 seconds.
5. Measure the maximum pressure several times while engine running.
6. If the pressure does not reach the allowable limit, apply few drops of oil to the cylinder wall through the nozzle holder hole and check the pressure again.
7. If the pressure rises after applying the oil, check the cylinder wall and piston ring for wear.
8. If the pressure is still low, check the top clearance, valve clearance and cylinder head.

Compression pressure	Specified value	3.24 ~ 3.73 MPa 33 ~ 38 kgf/cm <sup>2</sup> 469 ~ 540 psi
	Allowable lower limit	2.55 MPa 26 kgf/cm <sup>2</sup> 370 psi
Pressure difference between two cylinders	Allowable limit	10 %

**CAUTION**

- Check the compression pressure and adjust the valve clearance to the specified value.

## 5.3 VALVE CLEARANCE

### 5.3.1 4 CYL.

1. The valve clearance should be measured only when the engine temperature is same to the ambient temperature.
2. Disconnect the battery cables.
3. Remove the cylinder head cover.
4. Turn the crankshaft slowly and then stop it when the No. 4 cylinder (flywheel side) is at the overlap period.

#### REMARKS

- Special socket for rotating crankshaft

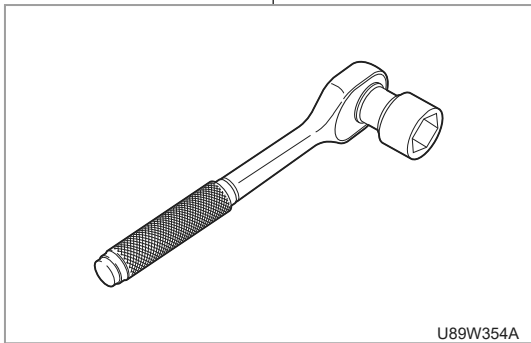
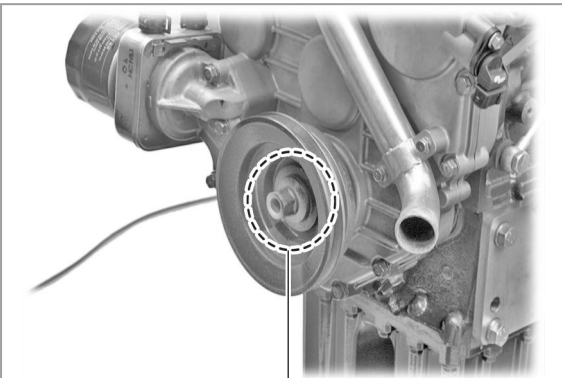

- When turning the crankshaft, use for bolt socket (B: 22 mm) with socket wrench.
- Turn the crankshaft clockwise viewed from the front of its bolt (bolt tightening direction).

5. Measure the clearance of the closed valves in the below table, which are the intake and exhaust valves of the No. 1 cylinder, the intake valve of the No. 2 cylinder and the exhaust valve of the No. 3 cylinder. Adjust the clearance if necessary.

#### WHEN THE NO. 4 CYLINDER IS OVERLAPPED

1		2		3		4	
IN	EX	IN	EX	IN	EX	IN	EX
●	●	●	○	○	●	○	○

●: closed, ○: open, ○: Overlap

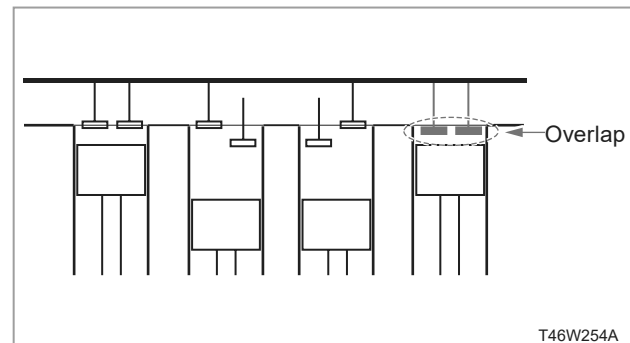

6. Turn the crankshaft just one turn (360°) to position the No. 1 cylinder valves to the overlap period.

#### REMARKS

##### Overlap:

When the exhaust stroke is completed and the intake stroke is about to start, the exhaust valve is about to close, which is still open, and the intake valve starts to open. This period is called "overlap" and the center of the overlap period is when the height of the rocker arms which push two valves is same. At this time, the clearance cannot be measured since the rocker arms push the intake and exhaust valves.

7. Measure the clearance of the closed valves in the below table, which are the exhaust valve of No. 2 cylinder, the intake valve of the No. 3 cylinder and the intake and exhaust valves of the No. 4 cylinder. Adjust the clearance if necessary.

**WHEN THE NO. 1 CYLINDER IS OVERLAPPED**

1		2		3		4	
IN	EX	IN	EX	IN	EX	IN	EX
●	●	○	●	●	○	●	●

●: closed, ○: open, ○: Overlap

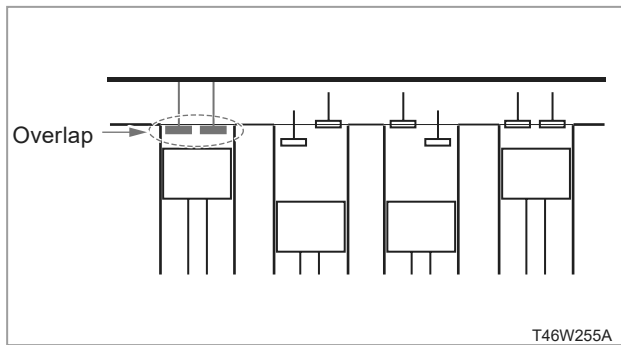

T46W255A

**! IMPOARTANT**

• Valve clearance

IN	EX
0.20 mm (0.00787 in.)	0.20 mm (0.00787 in.)

**5.4 VALVE LIFT (DEFLECTION AND WORN CONDITION OF VALVE CAM, TAPPET, PUSH ROD, ROCKER ARM, ETC.)**

1. Remove the cylinder head cover.
2. Adjust the valve clearance according to the section 5.3.
3. Set the dial gauge so that its pointer is on the valve. The valve should be closed and the rocker arm should move as much as the free play.
4. Measure the max. valve movement while turning the crankshaft.
5. Measure the max. vertical movement of other valves according to the above process.
6. The vertical movement for all valves should be in the tolerance range of 0.5 mm (0.02 in.). If the measured value is out of the tolerance, check the corresponding valve for the deflection of the pushrod, worn condition, engagement with the tappet, worn tappet and worn valve cam.

5.5 OIL PRESSURE MEASUREMENT

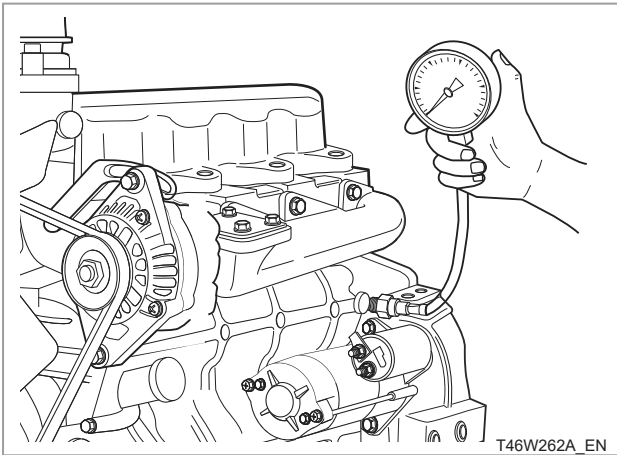

T46W262A\_EN

1. Remove the oil pressure switch and install the adapter and the pressure tester.
2. Start and warm up the engine. Then, measure the oil pressure at idle and rated speed.
3. If the oil pressure is less than the allowable limit, check the oil level, oil filter, oil pump relief valve, oil passages and oil clearance.

Engine oil pressure	At idle speed	Specified value	over 49 kPa 0.5 kgf/cm <sup>2</sup> 7.11 psi
	At rated speed	Specified value	245 ~ 441 kPa 2.5 ~ 4.5 kgf/cm <sup>2</sup> 35.6 ~ 64.0 psi
		Allowable limit (lower limit)	245 kPa 2.5 kgf/cm <sup>2</sup> 35.6 psi

**Oil pressure switch**

**Tightening torque ..... 14.7 ~ 19.6 Nm  
1.5 ~ 2.0 kgf-m  
10.8 ~ 14.5 lb-ft**

5.6 BUBBLE TEST FOR RADIATOR

REMARKS

- Checking if air is leaked through the crack on the cylinder wall

1. Check the coolant level of the radiator and the reservoir tank. Add the coolant if necessary.
2. Start the engine with the radiator cap closed and the reservoir tank cap open.
3. Check if any bubble can be seen in the overflow hose on the bottom of the reservoir tank around 5 minutes later.
4. If any bubble can be seen, remove the engine cylinder head to check the head gasket for damage, the cylinder bore for crack and the cylinder head for crack. Replace the components if necessary.

## 5.7 TURBO CHARGER WASTEGATE PRESSURE CHECK

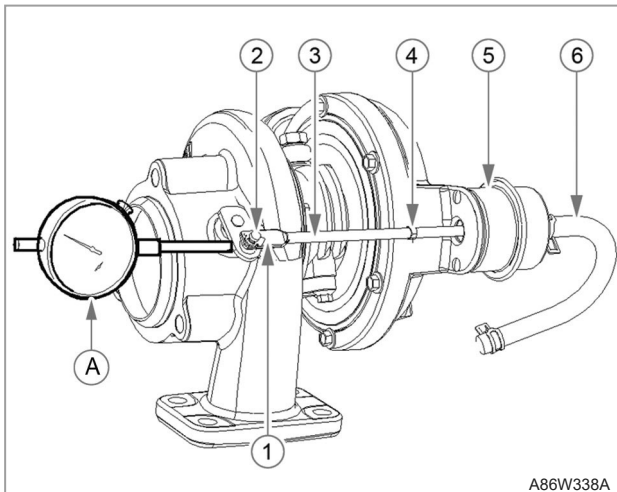

The wastegate is a valve that automatically opens at a preset level of boost pressure in order to allow excess exhaust gas to bypass the turbine at high engine speeds. The wastegate allows the design of the turbocharger to be more effective at lower engine speeds. The wastegate is controlled by a diaphragm. One side of this diaphragm is open to the atmosphere. The other side of this diaphragm is open to intake manifold boost pressure.

### PRESSURE CHECKING METHOD

1. Remove the boost line(6) from the wastegate actuator(5). Connect an air supply to the wastegate actuator that can be adjusted accurately.
2. Install Tooling(A) to the turbocharger so that the end of the actuator rod(1) is in contact with Tooling(A). This will measure axial movement of the actuator rod(4).
3. Slowly apply air pressure to the wastegate so that the actuator rod(4) moves 1.0 mm(0.039 in.). The air pressure should be within  $61 \pm 3$  kPa(8.89 psi) for 4B243T.

### REMARKS

- Ensure that the dial indicator returns to zero when the air pressure is released.

4. Repeat the test several times. This will ensure that an accurate reading is obtained. If the operation of the wastegate is not correct, the actuator rod(4) can not be adjusted. The turbocharger must be renewed.

### REMARKS

#### ACTUATOR FUNCTION

- When pressure of intake air drawn by the turbocharger rises, so does its temperature, and high temperature of intake air can lead to incomplete combustion. To prevent this situation, the turbocharger is equipped with the actuator. There is a pipe connected between the actuator and intake manifold and this pipe detects intake air pressure continuously. When the intake air pressure is over the setting value of the diaphragm of the actuator, the wastegate is opened to release exhaust gas on the compressor side of the turbocharger. Therefore, the turbine of the compressor is slowed down and so is the pressure of intake air. As a result, a proper amount of intake air is flowed into the cylinder through the intake manifold.

6. EXPLODED VIEW

REMARKS

- The manufacturing parts are subject to change without notice. Therefore, check the parts catalog or electronic manual for latest information.

6.1 EH5-G11001 CYLINDER BLOCK GROUP

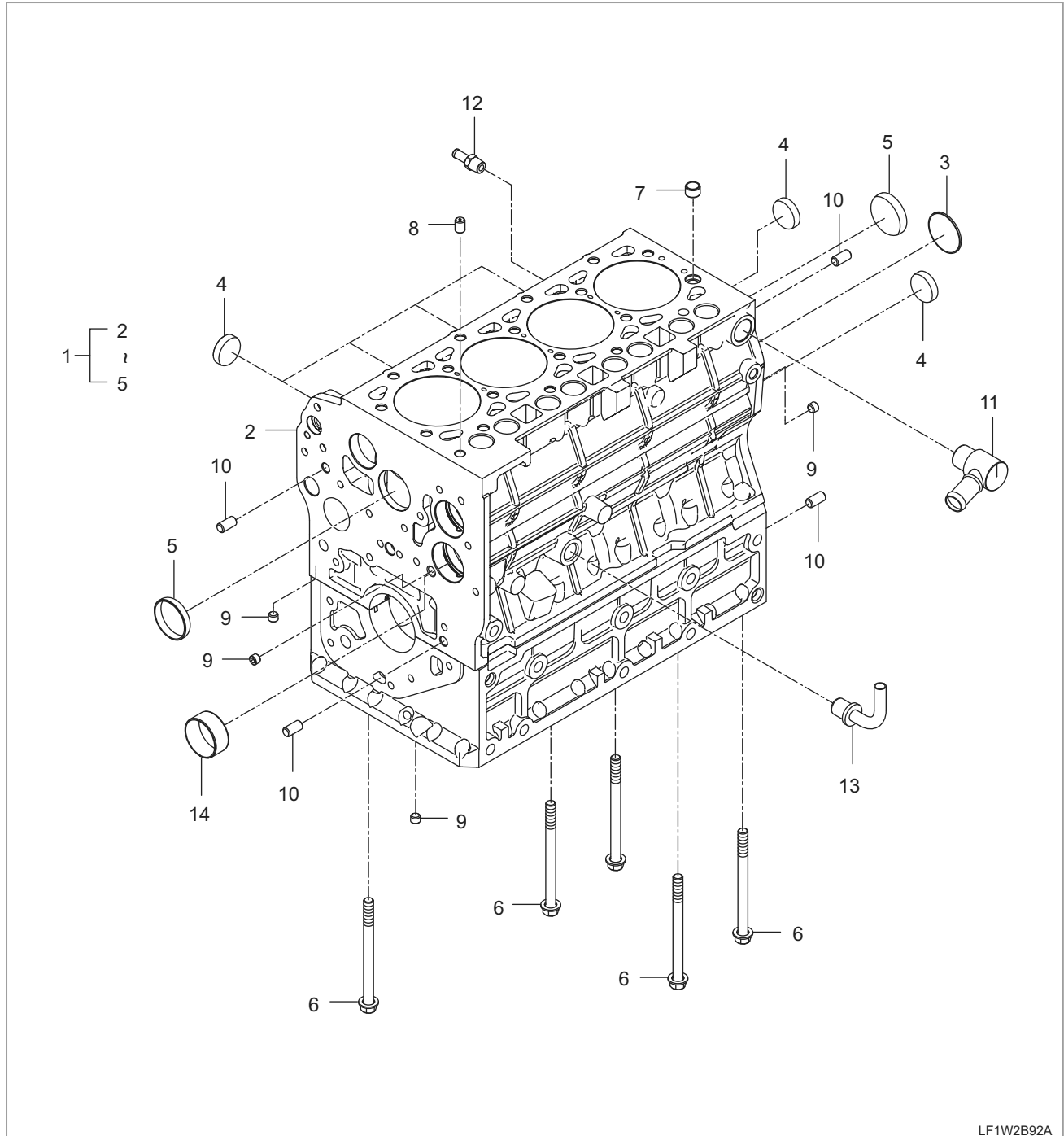

COMPONENTS

- |                             |                        |                             |
|-----------------------------|------------------------|-----------------------------|
| (1) Assy Block,Cylinder     | (6) Bolt, Ladder Frame | (11) Coolant Connector Assy |
| (2) Cylinder Block Sub Assy | (7) Tube Pin           | (12) Joint, Hose            |
| (3) Plug                    | (8) Pin                | (13) Pipe, Oil-3            |
| (4) Cap, Sealing            | (9) Plug               | (14) Bushing, Balance Shaft |
| (5) Cap, Sealing            | (10) Straight Pin      |                             |

SAFETY FIRST

ENGINE

DRIVING & CHASSIS

HYDRAULIC SYSTEM

ELECTRIC SYSTEM

CABIN

INDEX

6.2 EH5-G113003 CYLINDER HEAD GROUP

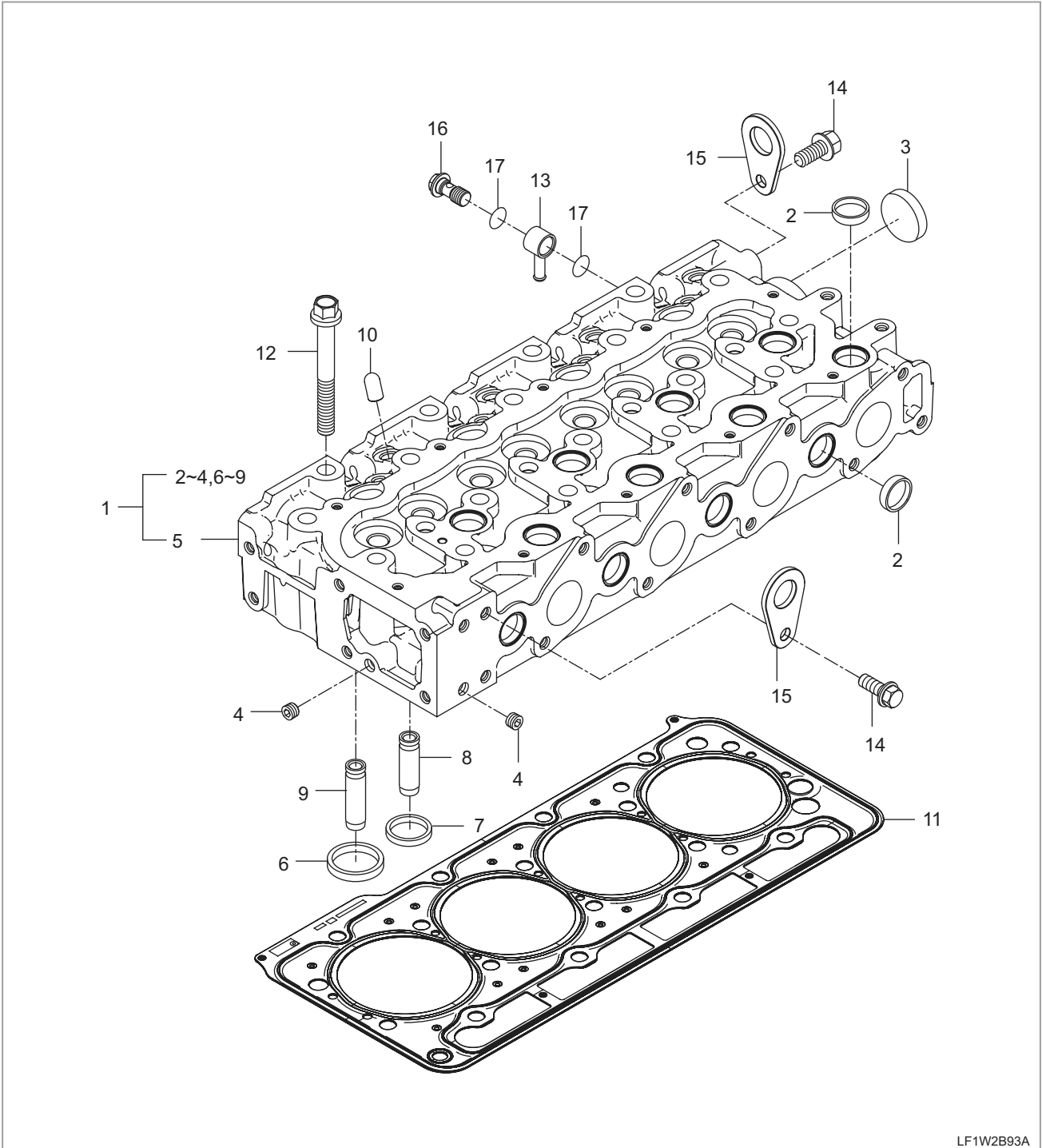

LF1W2B93A

COMPONENTS

- |                            |                            |                         |
|----------------------------|----------------------------|-------------------------|
| (1) Assy Head,Cylinder     | (7) Seat Exhaust Valve     | (13) Connector, Coolant |
| (2) Cap Sealing            | (8) Guide, Valve           | (14) Flange Bolt        |
| (3) Cap Sealing            | (9) Guide, Intake Valve    | (15) Engine Hook        |
| (4) Plug                   | (10) Hinge, Injector Clamp | (16) Joint Bolt         |
| (5) Cylinder Head Sub Assy | (11) Gasket,Head           | (17) O Ring             |
| (6) Seat Intake Valve      | (12) Bolt,Cylinder Head    |                         |

6.3 EH5-G114002 GEAR CASE GROUP

SAFETY FIRST

ENGINE

DRIVING & CHASSIS

HYDRAULIC SYSTEM

ELECTRIC SYSTEM

CABIN

INDEX

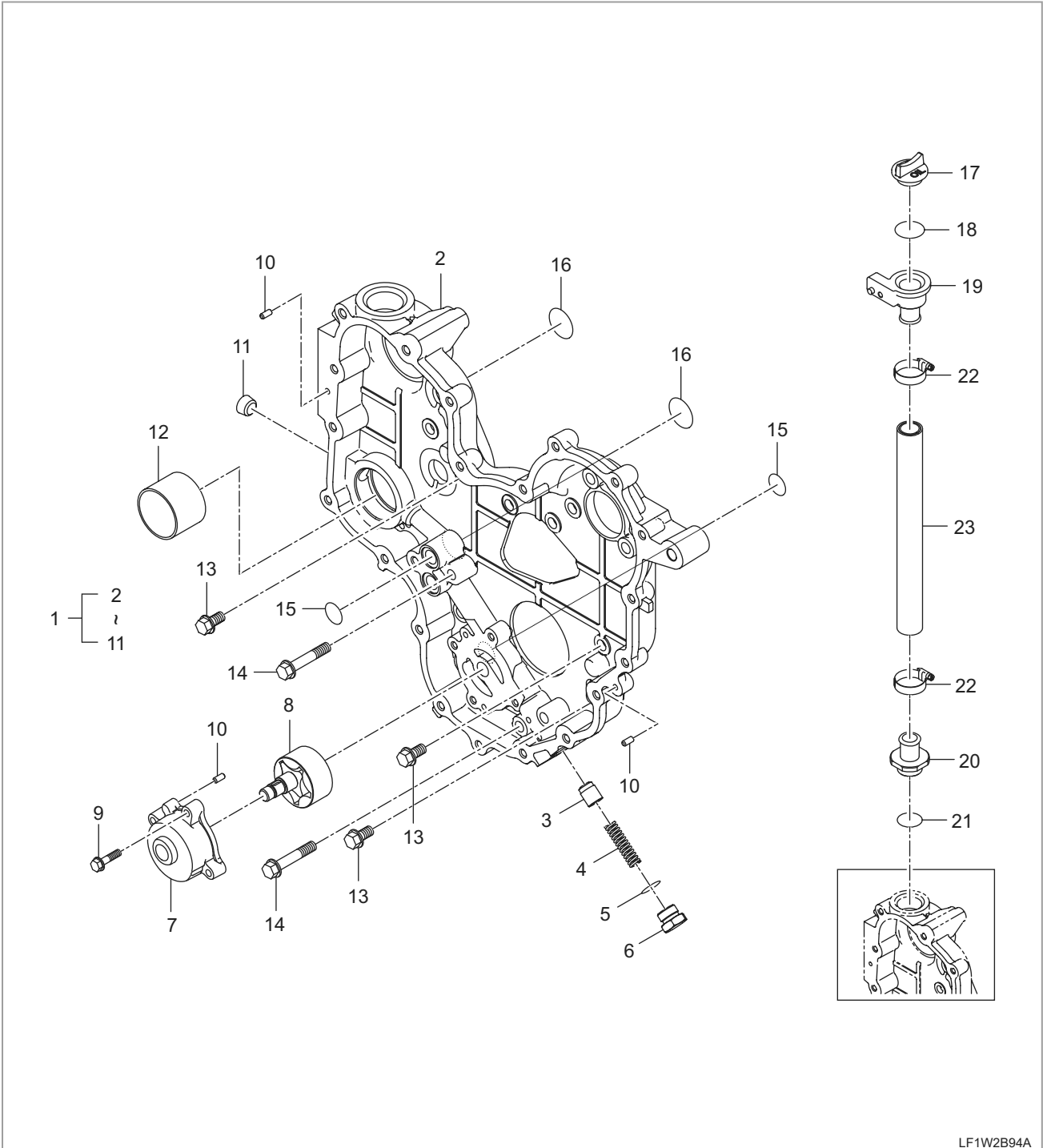

LF1W2B94A

COMPONENTS

- |                               |                      |                             |
|-------------------------------|----------------------|-----------------------------|
| (1) Assy Case,Gear            | (9) Bolt, Flange     | (17) Plug, Oil Filler       |
| (2) Gear Case                 | (10) Pin,Straight    | (18) O Ring                 |
| (3) Plunger, Relief Valve     | (11) Plug            | (19) Flange, Oil Filler-UPR |
| (4) Spring Relief Valve       | (12) Bush, PTO Shaft | (20) Flange, Oil Filler-LWR |
| (5) O Ring                    | (13) Flange Bolt     | (21) O Ring                 |
| (6) Plug, Relief Valve        | (14) Bolt            | (22) Band, Hose             |
| (7) Cover, Oil Pump           | (15) O Ring          | (23) Hose, Oil              |
| (8) Oil Pump Rotor Shaft Assy | (16) O Ring          |                             |



6.4 EH5-G121001 CRANK SHAFT GROUP

SAFETY FIRST

ENGINE

DRIVING & CHASSIS

HYDRAULIC SYSTEM

ELECTRIC SYSTEM

CABIN

INDEX

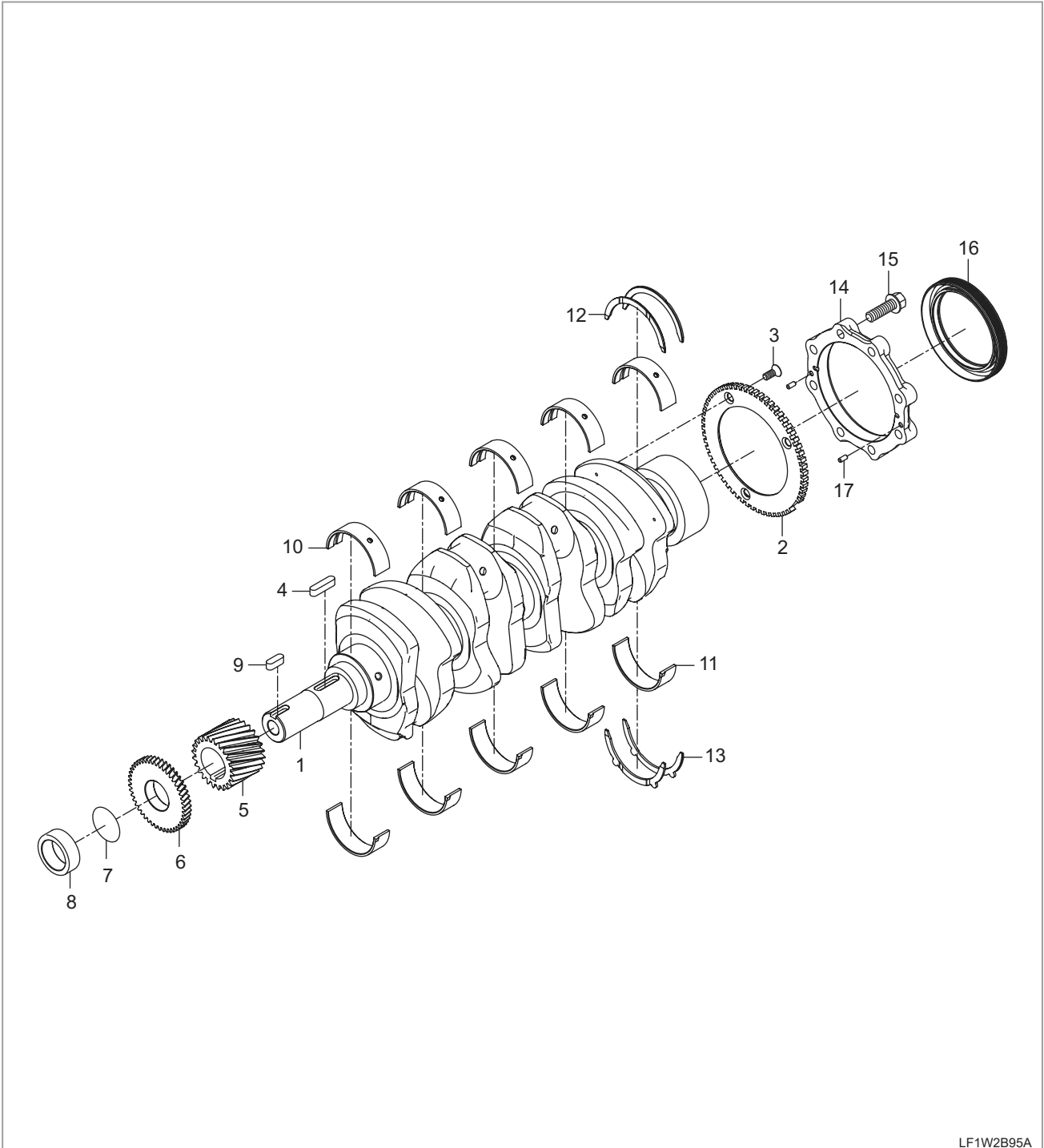

LF1W2B95A

COMPONENTS

- (1) Shaft,Crank
- (2) Wheel, Crank Position Sensor
- (3) Cross-Recessed Head Machine Screw
- (4) Feather Key
- (5) Gear, Crankshaft
- (6) Gear, Oil Pump Drive
- (7) O Ring
- (8) Spacer
- (9) Feather Key
- (10) Bearing-Crankshaft UPR
- (11) Bearing-Crankshaft LWR
- (12) Bearing, Crankshaft Thrust UPR
- (13) Bearing-Crankshaft Thrust LWR
- (14) Case, Oil Seal
- (15) Bolt
- (16) Oil Seal
- (17) Straight Pin

6.5 EH5-G122001 PISTON CONNECTING ROD GROUP

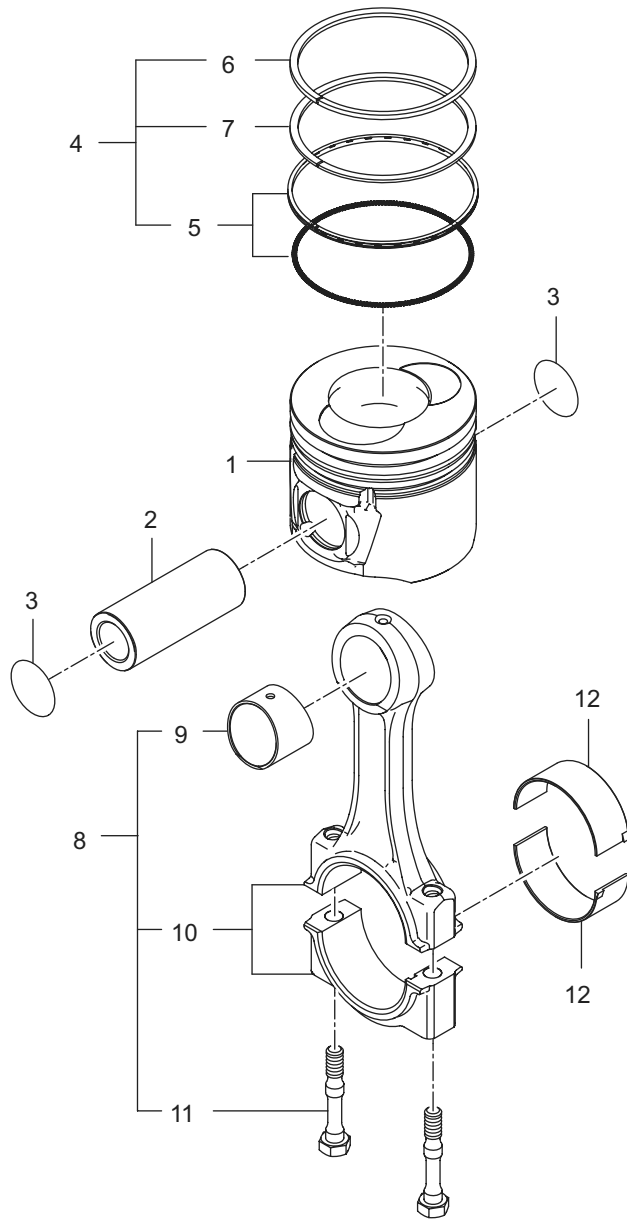

LF1W2B96A

COMPONENTS

- |                      |                         |                              |
|----------------------|-------------------------|------------------------------|
| (1) Piston           | (5) Assy,Oil Ring       | (9) Connecting Rod Bush      |
| (2) Pin, Piston      | (6) Ring 1, Piston      | (10) Connectingrod           |
| (3) Snapring         | (7) Ring 2, Piston      | (11) Connecting Rod Bolt     |
| (4) Piston Ring Assy | (8) Connecting Rod Assy | (12) Bearing, Connecting Rod |

SAFETY FIRST

ENGINE

DRIVING & CHASSIS

HYDRAULIC SYSTEM

ELECTRIC SYSTEM

CABIN

INDEX

6.6 EH5-G123001 CAMSHAFT GROUP

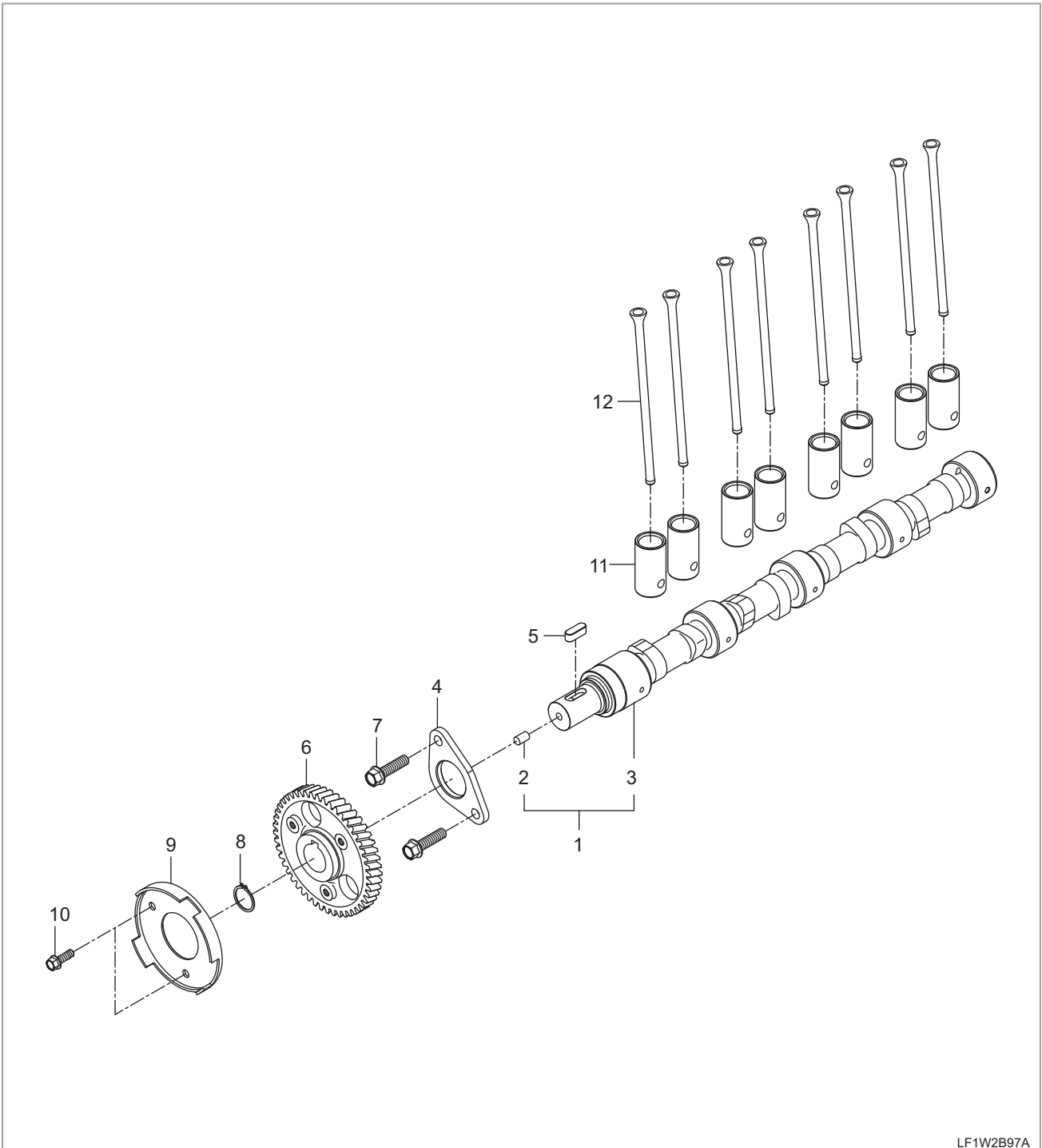

LF1W2B97A

COMPONENTS

- |                       |                    |                            |
|-----------------------|--------------------|----------------------------|
| (1) Assy Camshaft     | (5) Feather Key    | (9) Wheel, Camshaft Sensor |
| (2) Plug, Set         | (6) Gear, Camshaft | (10) Flange Bolt           |
| (3) Camshaft          | (7) Flange Bolt    | (11) Tappet                |
| (4) Stopper, Camshaft | (8) Ring, Snap     | (12) Rod, Push             |

## 6.7 EH5-G124002 IDLE GEAR GROUP

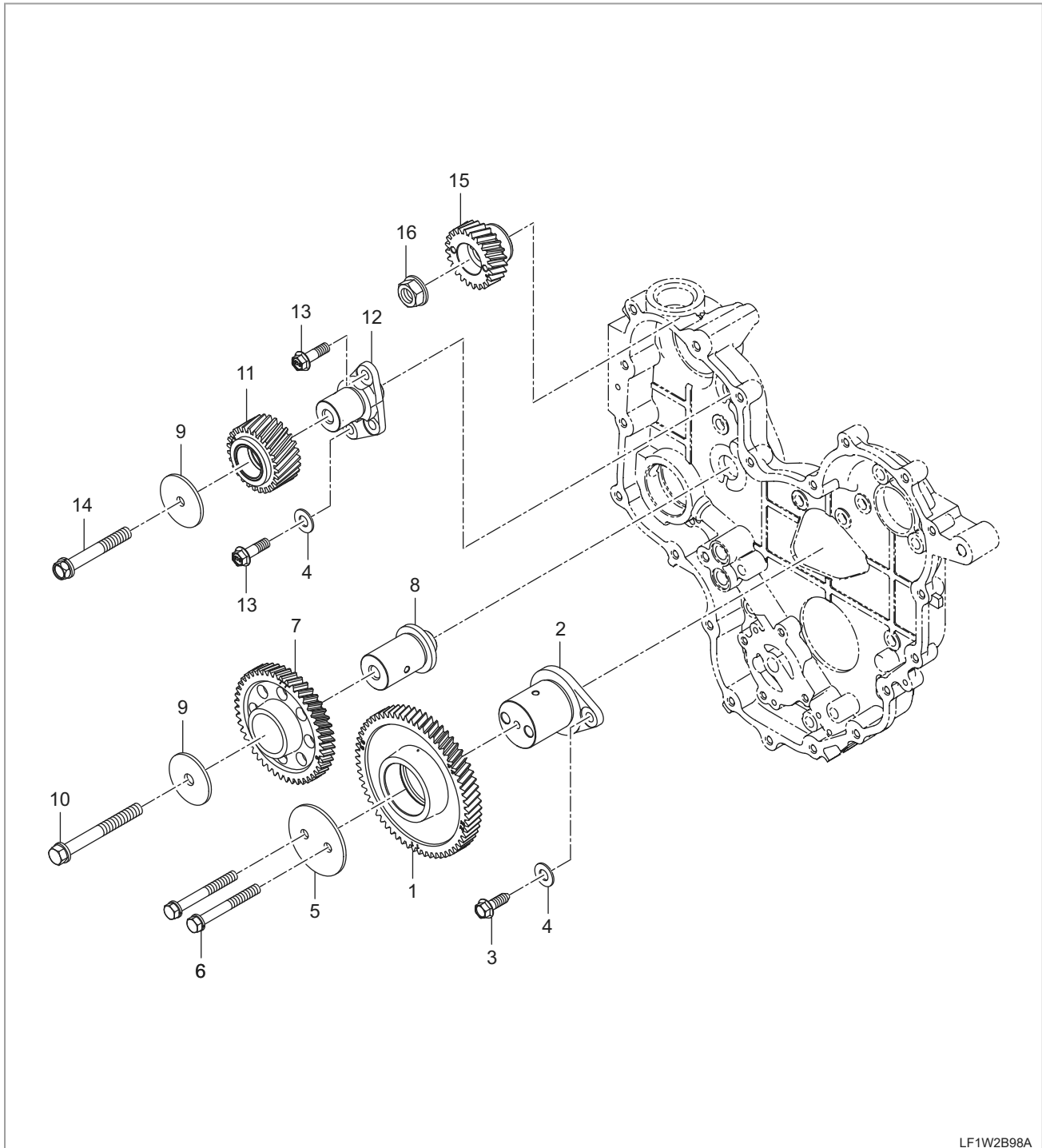

LF1W2B98A

## COMPONENTS

- |                          |                          |                         |
|--------------------------|--------------------------|-------------------------|
| (1) Ass'y Idle Gear1     | (7) Ass'y Idle Gear3     | (13) Bolt, Flange       |
| (2) Shaft, Idlegear1     | (8) Shaft 3, Idle Gear   | (14) Bolt, With Washer  |
| (3) Bolt, Flange         | (9) Stopper 2, Idle Gear | (15) Gear, Hp Fuel Pump |
| (4) Washer, Knock        | (10) With Washer Bolt    | (16) Flange Nut         |
| (5) Stopper 1, Idle Gear | (11) Ass'y Idle Gear4    |                         |
| (6) With Washer Bolt     | (12) Shaft, Idlegear4    |                         |

6.8 EH5-G125001 ROCKER ARM VALVE GROUP

SAFETY FIRST

ENGINE

DRIVING & CHASSIS

HYDRAULIC SYSTEM

ELECTRIC SYSTEM

CABIN

INDEX

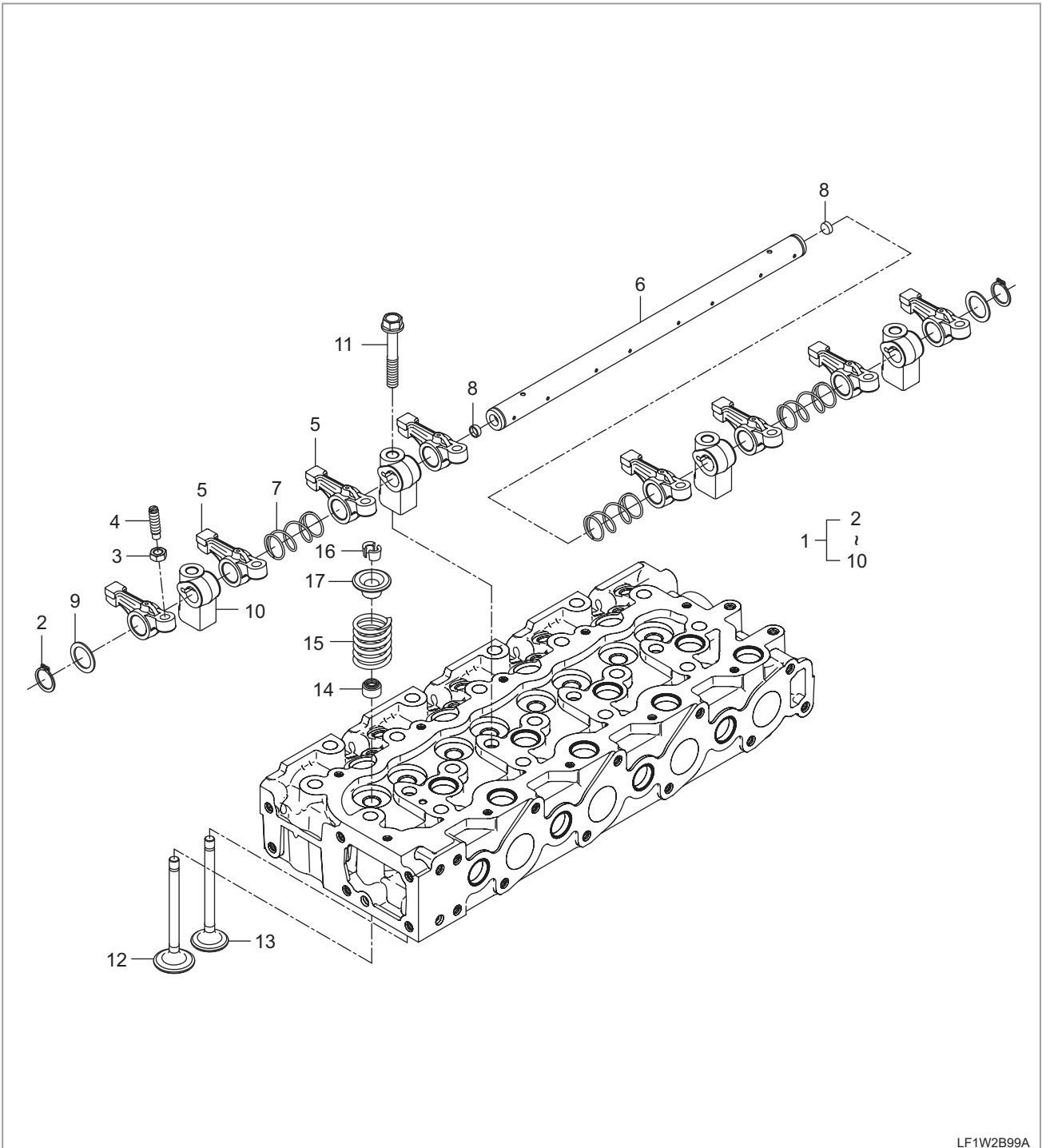

LF1W2B99A

COMPONENTS

- |                     |                               |                            |
|---------------------|-------------------------------|----------------------------|
| (1) Assy Arm,Rocker | (7) Rockerarm Spring          | (13) Valve, Exhaust        |
| (2) Snap Ring       | (8) Cap, Sealing              | (14) Seal, Valve Stem      |
| (3) Nut             | (9) Washer                    | (15) Spring, Valve         |
| (4) Screw,Adjust    | (10) Bracket, Rocker Arm      | (16) Collet,Valve Spring   |
| (5) Arm, Rocker     | (11) Bolt, Rocker Arm Support | (17) Retainer,Valve Spring |
| (6) Rockerarm Shaft | (12) Valve, Intake            |                            |

## 6.9 EH5-G131001 INTAKE MANIFOLD GROUP

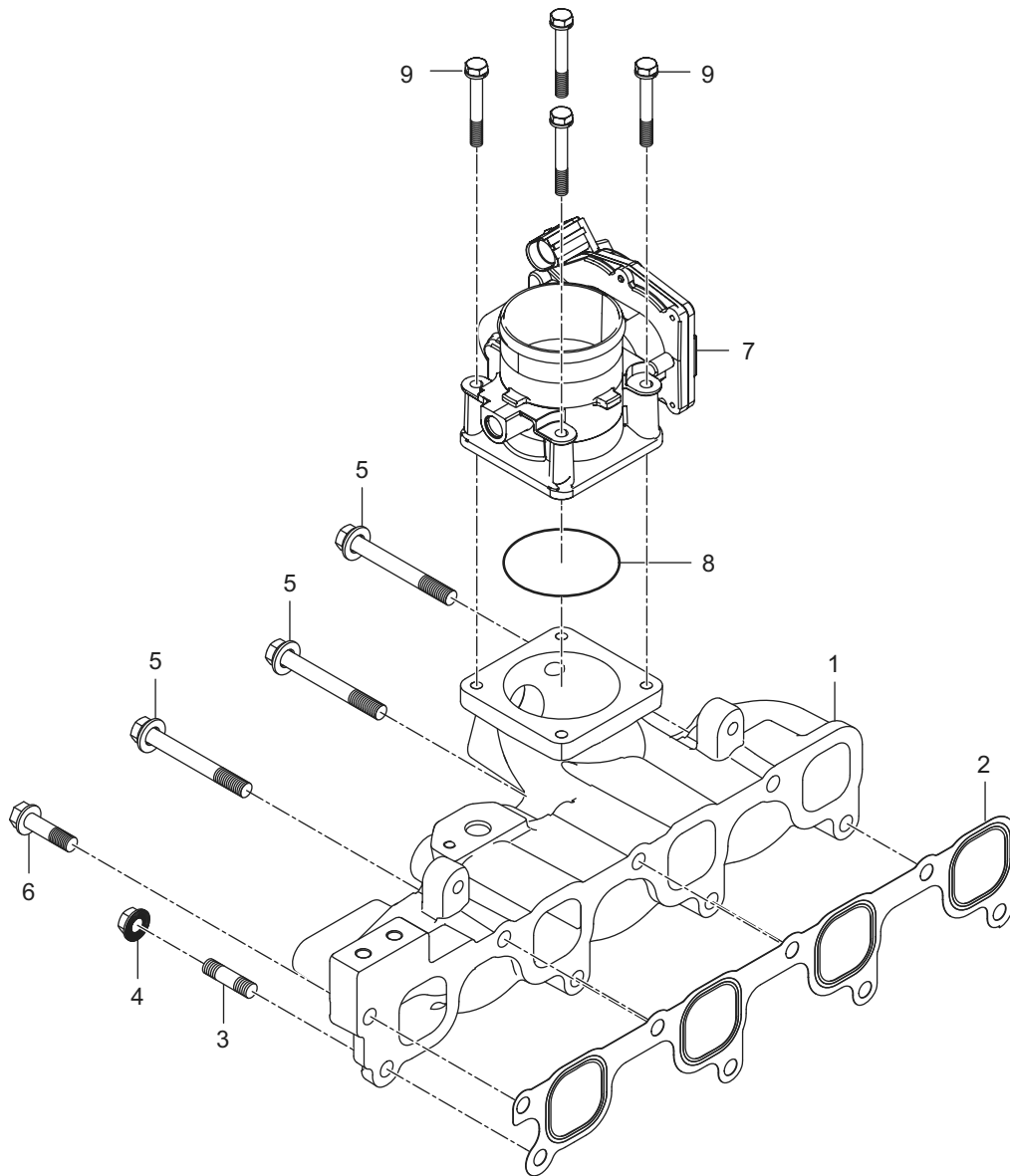

LF1W2C01A

**COMPONENTS**

- |                             |                      |                            |
|-----------------------------|----------------------|----------------------------|
| (1) Manifold, Inlet         | (4) Flange Nut       | (7) Air Control Valve Assy |
| (2) Gasket, Intake Manifold | (5) With Washer Bolt | (8) O Ring-ACV             |
| (3) Stud Bolt               | (6) Flange Bolt      | (9) Bolt With Washer       |

6.10 EH5-G134001 TURBO GROUP

SAFETY FIRST

ENGINE

DRIVING & CHASSIS

HYDRAULIC SYSTEM

ELECTRIC SYSTEM

CABIN

INDEX

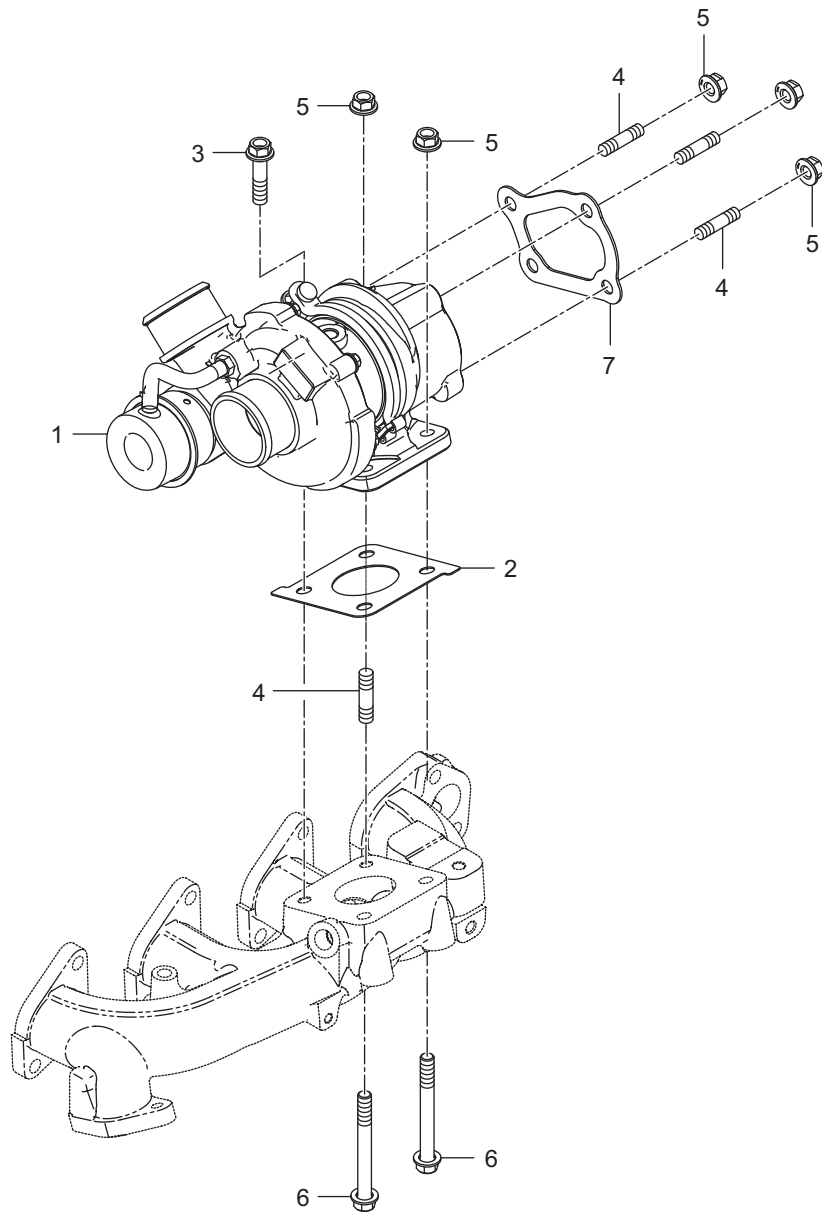

LF1W2C02A

COMPONENTS

- |                            |                 |                            |
|----------------------------|-----------------|----------------------------|
| (1) Turbocharger Assy      | (4) Bolt, Stud  | (7) Gasket 2, Turbocharger |
| (2) Gasket 1, Turbocharger | (5) Nut, U      |                            |
| (3) Bolt, Flange           | (6) Flange Bolt |                            |

## 6.11 EH5-G135001 TURBO PIPE GROUP

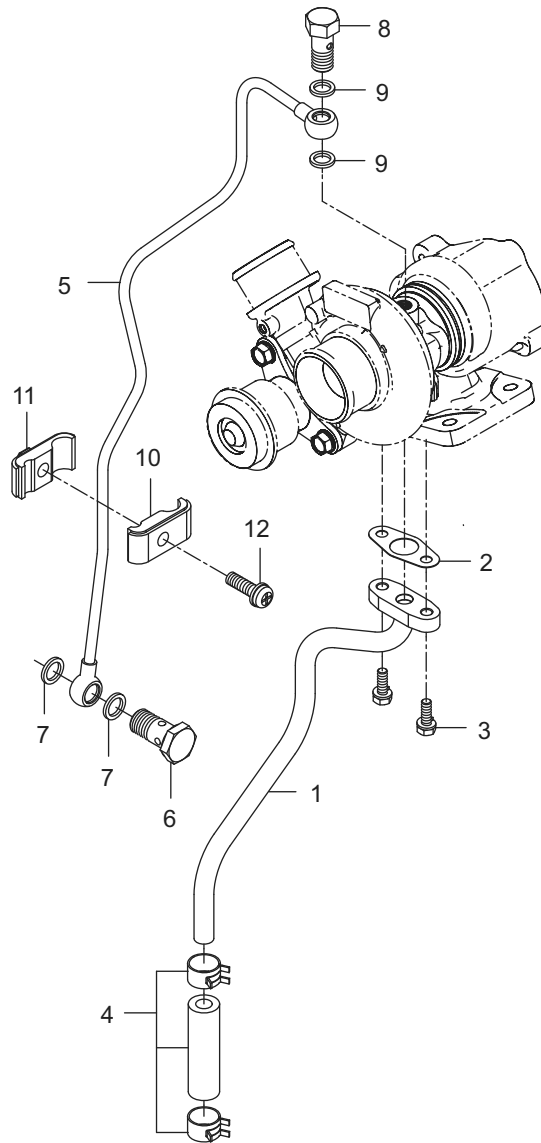

LF1W2C03A

**COMPONENTS**

- |                            |                           |                       |
|----------------------------|---------------------------|-----------------------|
| (1) Oil Drain Pipe Assy    | (5) Oil Feeding Pipe Assy | (9) Gasket            |
| (2) Gasket, Turbocharger-3 | (6) Eye Bolt              | (10) Clamp 1, Tube    |
| (3) With Washer Bolt       | (7) Packing               | (11) Clamp 2, Tube    |
| (4) Hose, Oil Ass'Y        | (8) Connector 2           | (12) With Washer Bolt |



6.12 EH5-G141001 OIL PUMP GROUP

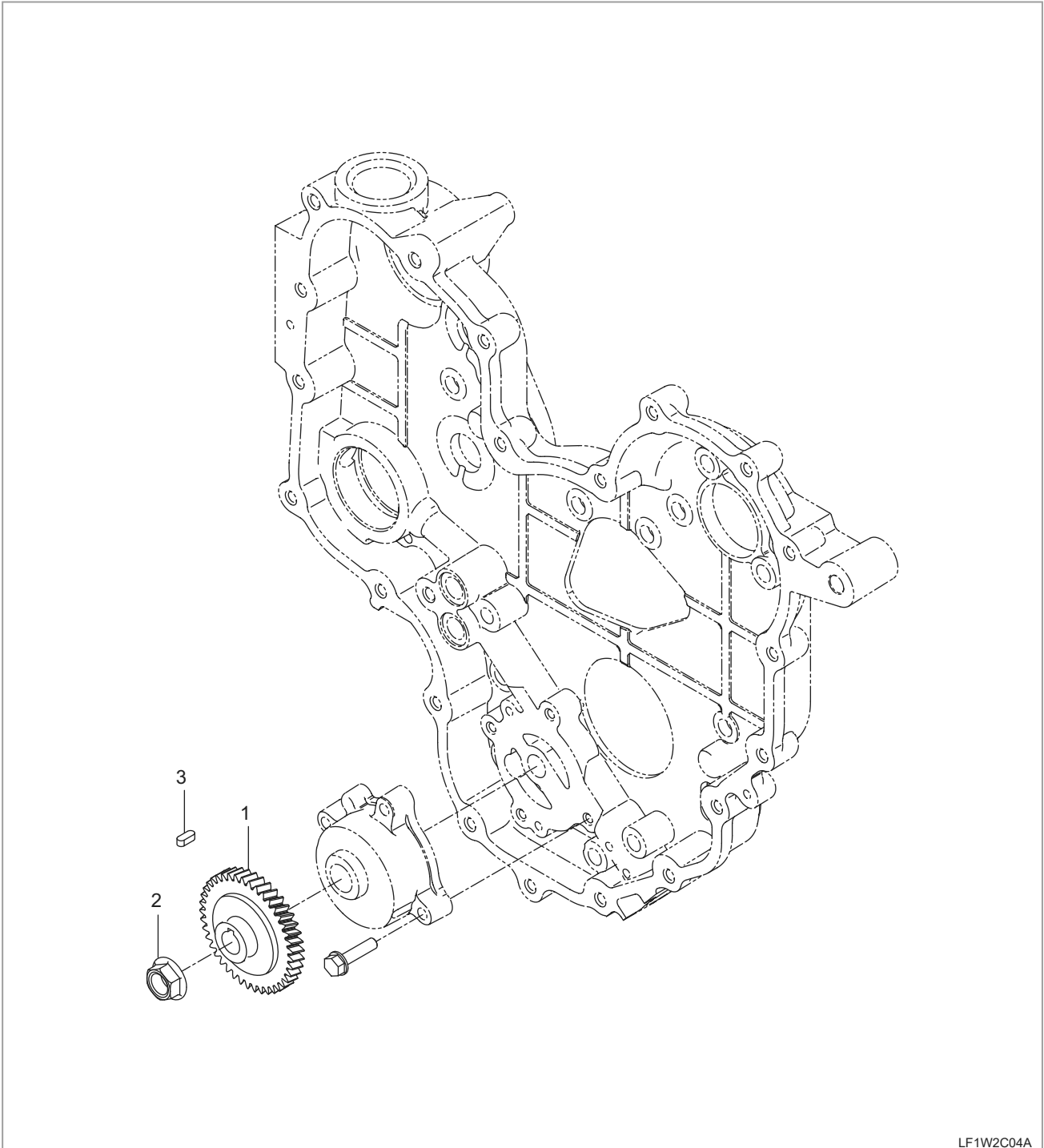

LF1W2C04A

COMPONENTS

(1) Gear, Oil Pump

(2) Flange Nut

(3) Feather Key

SAFETY FIRST

ENGINE

DRIVING & CHASSIS

HYDRAULIC SYSTEM

ELECTRIC SYSTEM

CABIN

INDEX

## 6.13 EH5-G144001 OIL FILTER GROUP

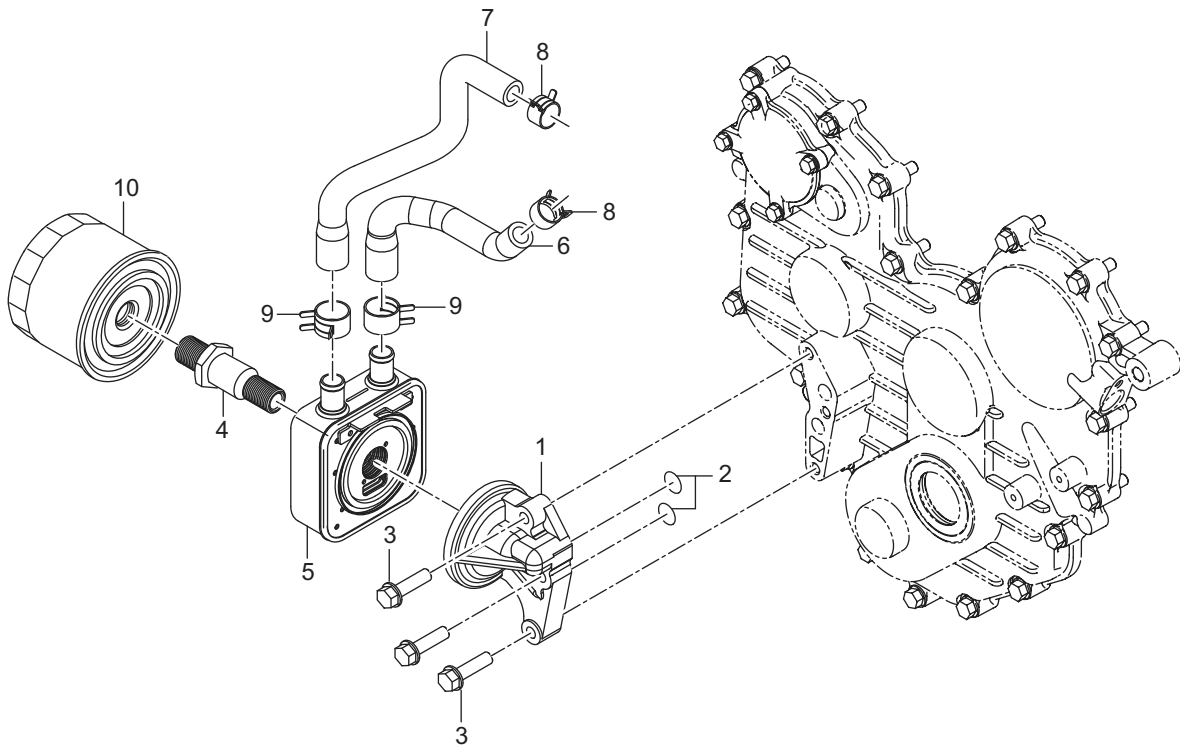

LF1W2C05A

**COMPONENTS**

- |                         |                        |                 |
|-------------------------|------------------------|-----------------|
| (1) Support, Oil Filter | (5) Cooler, Oil        | (9) Hose Clip   |
| (2) O Ring              | (6) Hose 1, Oil Cooler | (10) Oil Filter |
| (3) Flange Bolt         | (7) Hose 2, Oil Cooler |                 |
| (4) Tube, Connecting    | (8) Hose Clip          |                 |

6.14 EH5-G151001 FUEL EQUIPMENT GROUP

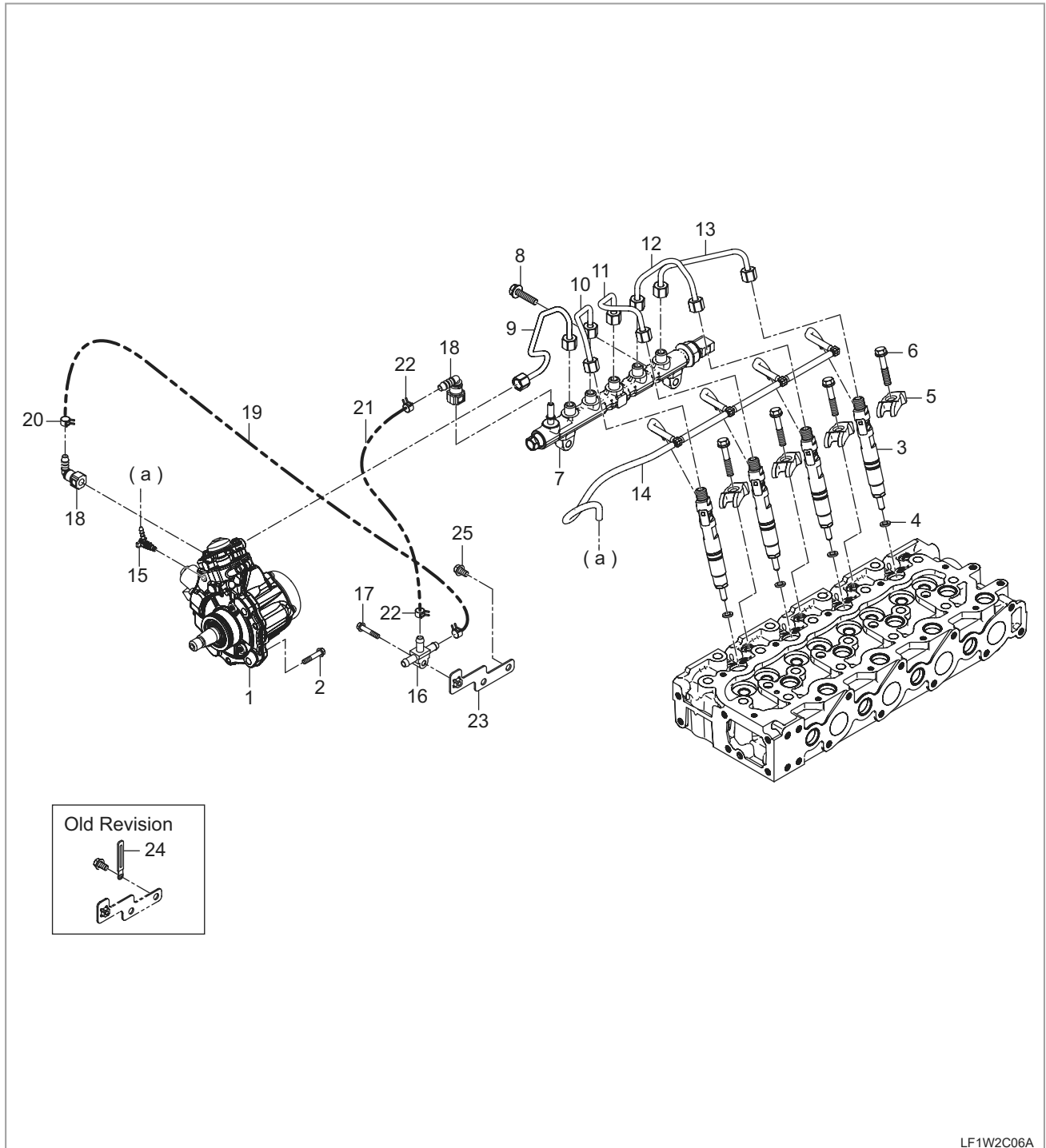

LF1W2C06A

COMPONENTS

- |                          |                                   |                        |
|--------------------------|-----------------------------------|------------------------|
| (1) Assy Pump, Hp Fuel   | (10) Pipe 1, Injection            | (19) Hose, Fuel        |
| (2) Flange Bolt          | (11) Pipe, Injection-2            | (20) Hose Clip         |
| (3) Assy Injector        | (12) Pipe, Injection-3            | (21) Hose, Fuel        |
| (4) Seat, Injector       | (13) Pipe, Injection-4            | (22) Clip, Tube        |
| (5) Clmap, Injector      | (14) Assy Tube, Injector Return   | (23) Bracket-Fuel Hose |
| (6) Bolt, Injector Clmap | (15) Connector                    | (24) Clamp,Cord        |
| (7) Assy Rail, Fuel      | (16) Joint, Fuel Hose             | (25) Bolt              |
| (8) Flange Bolt          | (17) Flange Bolt                  |                        |
| (9) Pipe, Rail           | (18) Connector, Quick-128-783-002 |                        |

6.15 EH5-G162001 WATER FLANGE GROUP

SAFETY FIRST

ENGINE

DRIVING & CHASSIS

HYDRAULIC SYSTEM

ELECTRIC SYSTEM

CABIN

INDEX

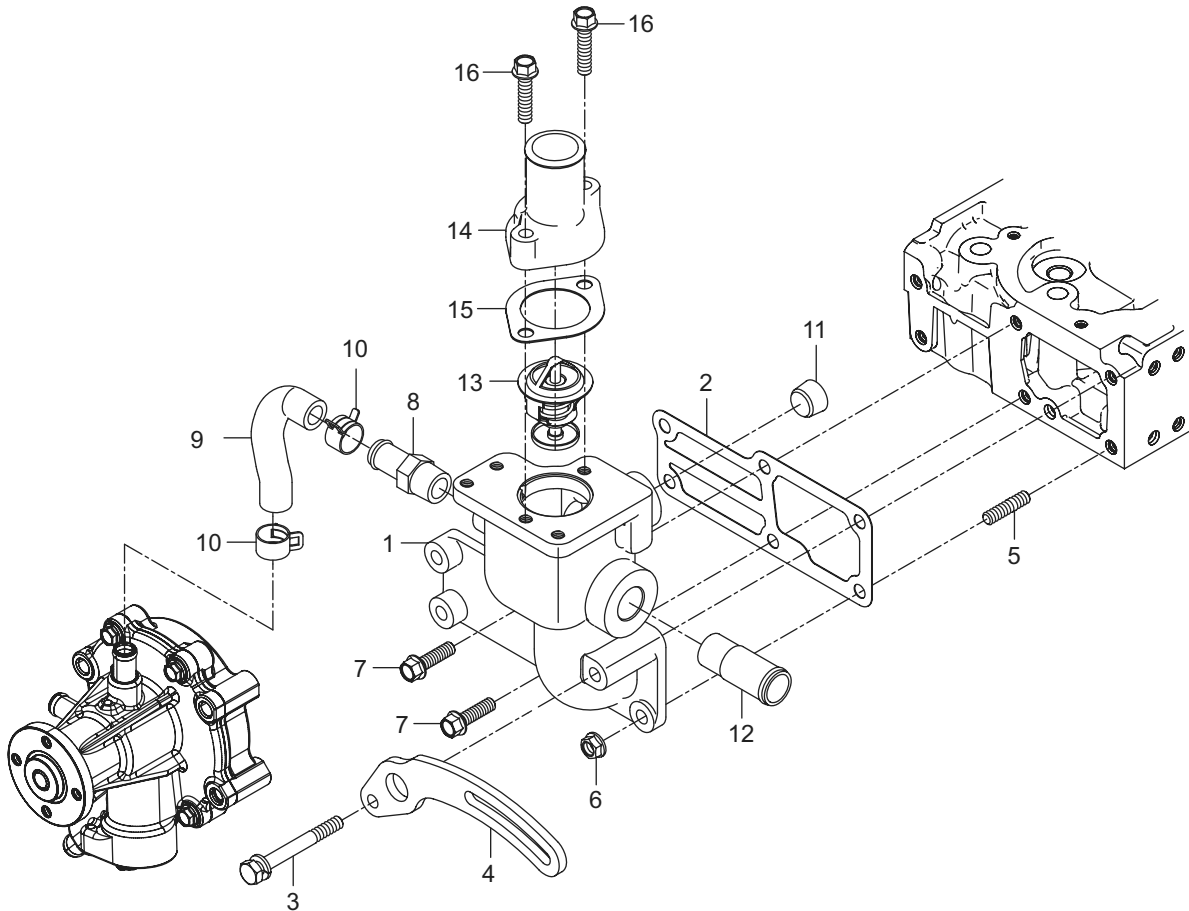

LF1W2C07A

COMPONENTS

- |                                  |                          |                          |
|----------------------------------|--------------------------|--------------------------|
| (1) Plange, Water                | (7) Bolt, Flange         | (13) Thermostat Assembly |
| (2) Gasket, Cooling Water Flange | (8) Pipe, Water Return   | (14) Thermostat Cover    |
| (3) With Washer Bolt             | (9) Hose, Coolant Return | (15) Gasket              |
| (4) Support, Alternator          | (10) Hose Clip           | (16) Flange Bolt         |
| (5) Stud Bolt                    | (11) Plug                |                          |
| (6) Flange Nut                   | (12) Connector, Coolant  |                          |

6.16 EH5-G163003 WATER PUMP GROUP

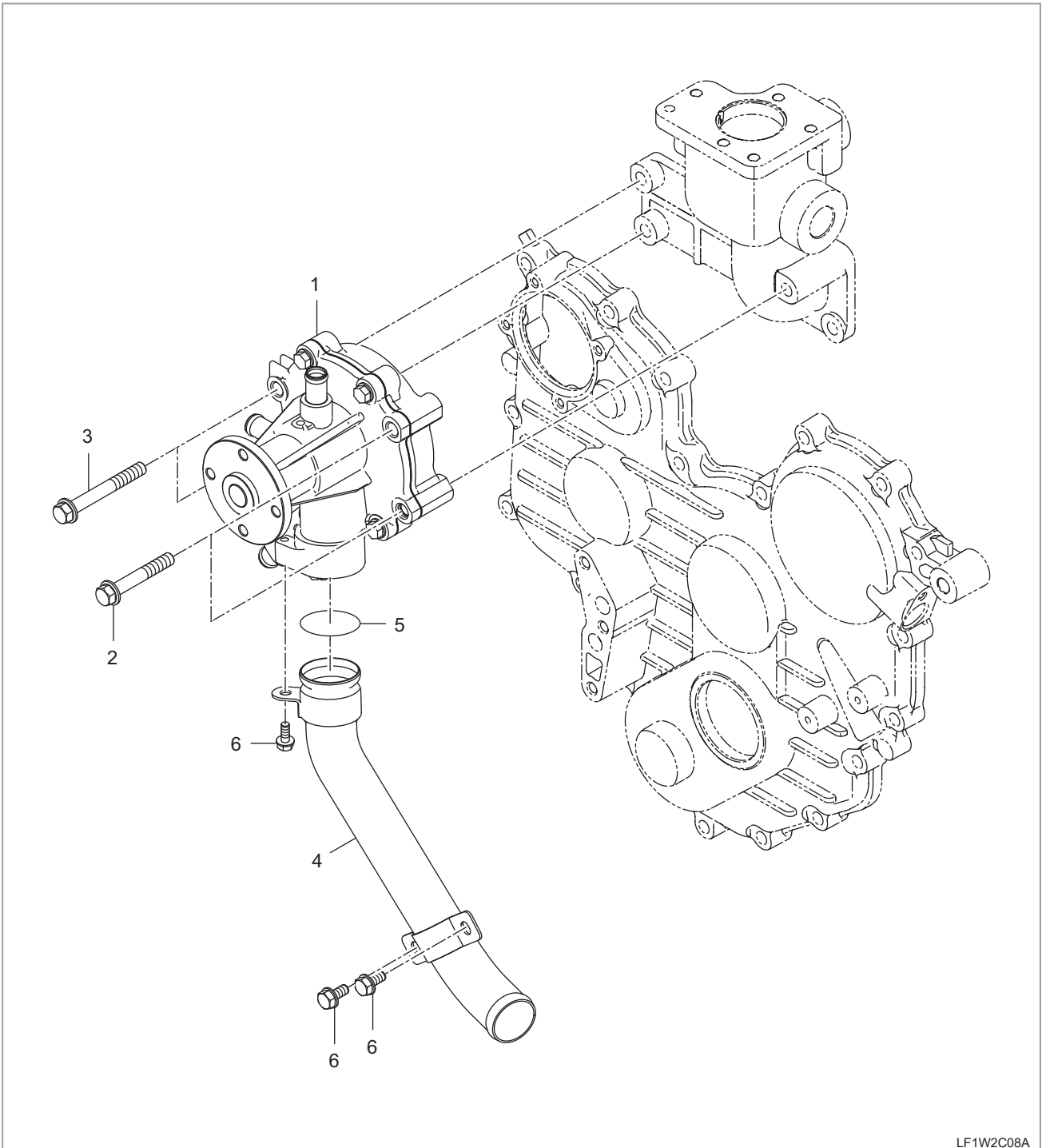

LF1W2C08A

**COMPONENTS**

- |                               |                           |                 |
|-------------------------------|---------------------------|-----------------|
| (1) Assy Pump, Water          | (3) With Washer Bolt      | (5) O Ring      |
| (2) Hex Head Bolt With Washer | (4) Assy Pipe, Water Pump | (6) Flange Bolt |

SAFETY FIRST

ENGINE

DRIVING & CHASSIS

HYDRAULIC SYSTEM

ELECTRIC SYSTEM

CABIN

INDEX

6.17 EH5-G171001 EGR GROUP

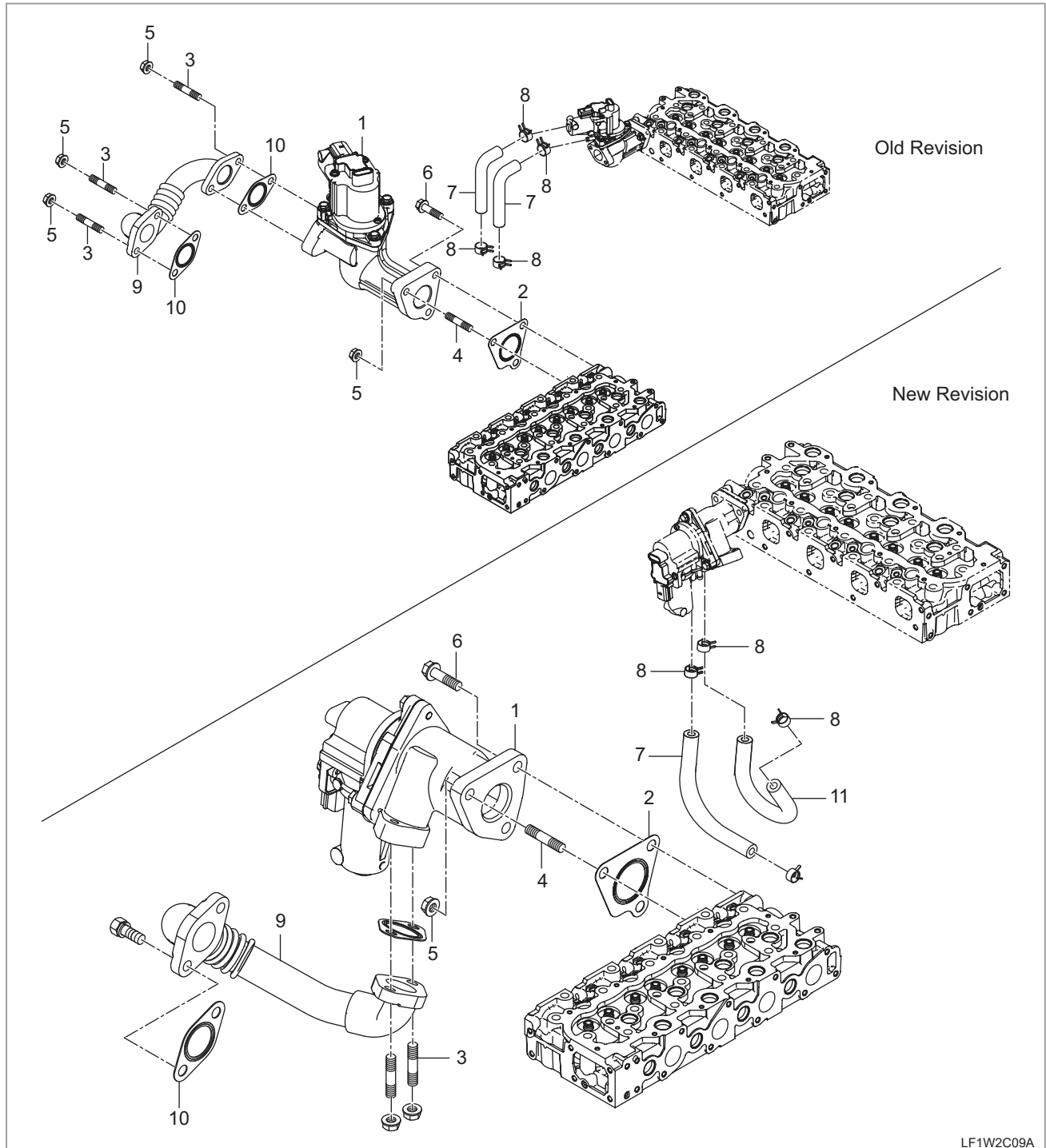

LF1W2C09A

COMPONENTS

- |                                |                   |                    |
|--------------------------------|-------------------|--------------------|
| (1) EGR Valve And Housing Assy | (5) Flange Nut    | (9) Assy Pipe, EGR |
| (2) Gasket, EGR Housing        | (6) Flange Bolt   | (10) Gasket, EGR   |
| (3) Stud Bolt                  | (7) Hose, Cooling | (11) Cooling Hose  |
| (4) Stud Bolt                  | (8) Hose Clip     |                    |

SAFETY FIRST

ENGINE

DRIVING & CHASSIS

HYDRAULIC SYSTEM

ELECTRIC SYSTEM

CABIN

INDEX

6.18 EH5-G172001 EGR COOLER GROUP

SAFETY FIRST

ENGINE

DRIVING & CHASSIS

HYDRAULIC SYSTEM

ELECTRIC SYSTEM

CABIN

INDEX

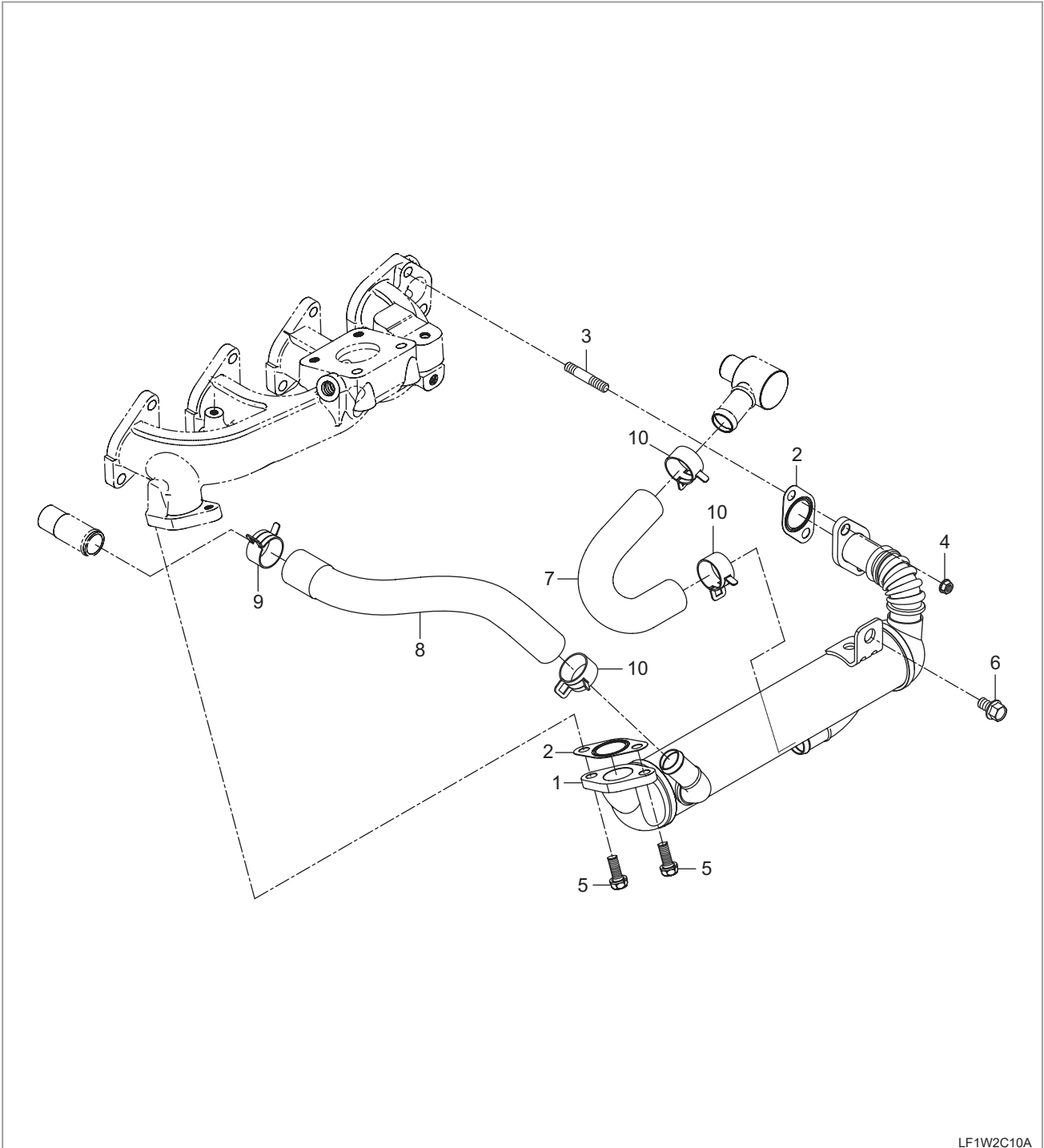

COMPONENTS

- |                     |                        |                |
|---------------------|------------------------|----------------|
| (1) EGR Cooler Assy | (5) Washer Bolt        | (9) Hose Clip  |
| (2) Gasket, EGR     | (6) Hex Head Cap Screw | (10) Hose Clip |
| (3) Stud Bolt       | (7) Hose 1, EGR Cooler |                |
| (4) Nut, U          | (8) Hose 2, EGR Cooler |                |

## 6.19 EH5-G191002 GLOW PLUG GROUP

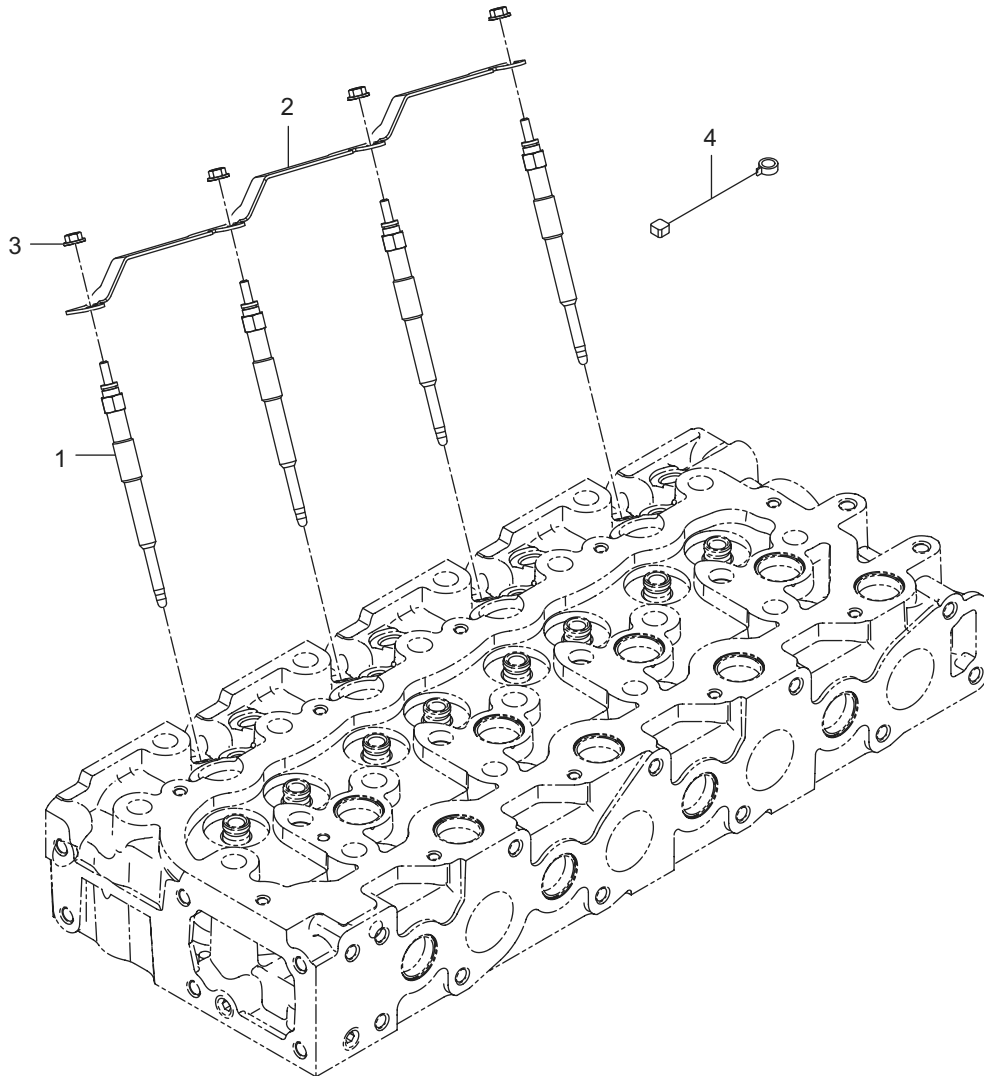

LF1W2C11A

**COMPONENTS**

- |                     |   |
|---------------------|---|
| (1) Plug, Glow      | (3) Flang Nut                               |
| (2) Cord, Glow Plug | (4) Glow Plug Connection Wire Harness Assay |



6.20 EH5-G192001 ENGINE ELECTRICAL GROUP

SAFETY FIRST

ENGINE

DRIVING & CHASSIS

HYDRAULIC SYSTEM

ELECTRIC SYSTEM

CABIN

INDEX

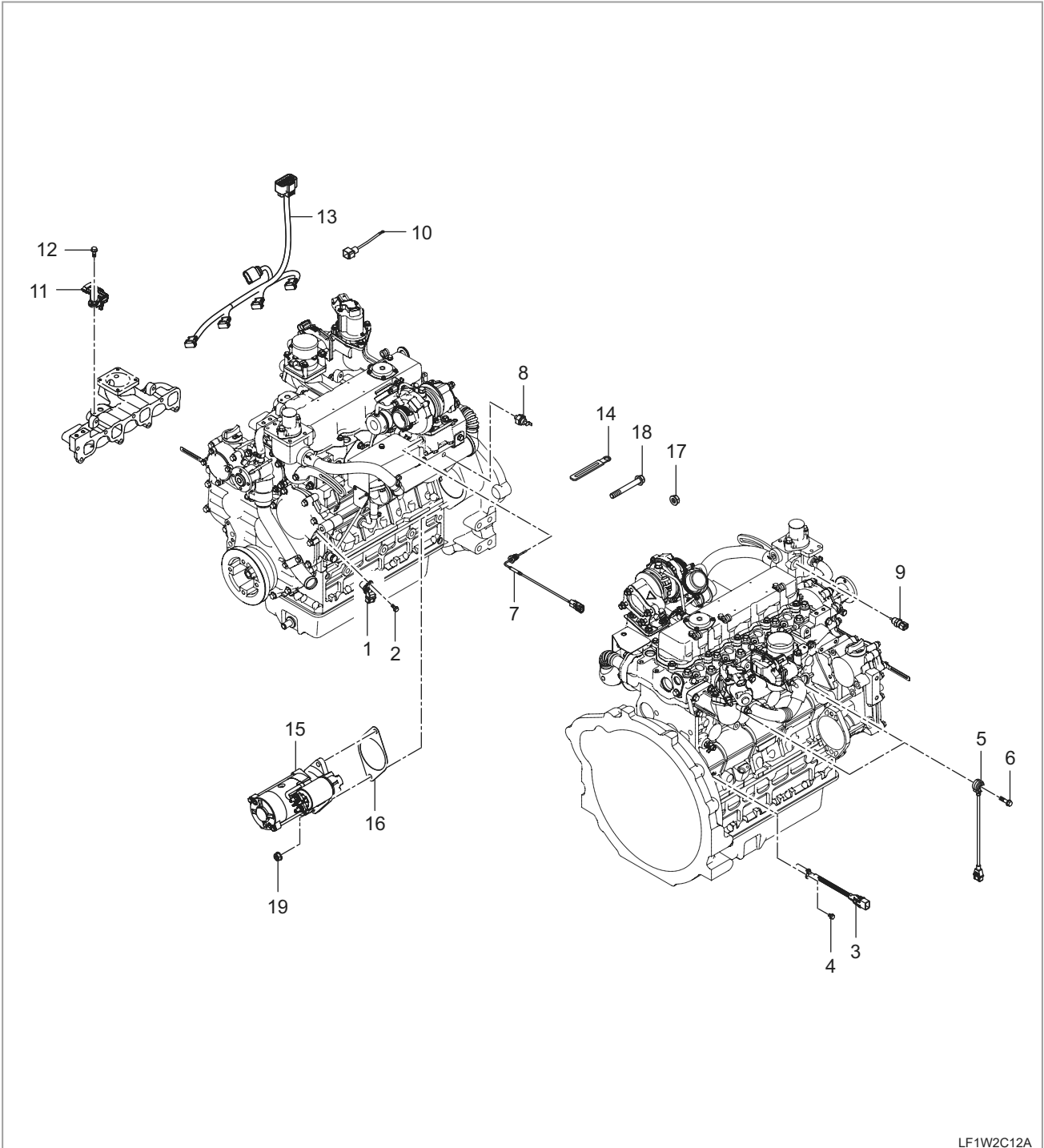

LF1W2C12A

COMPONENTS

- |                                    |                              |                       |
|------------------------------------|------------------------------|-----------------------|
| (1) Sensor, Camshaft Wheel         | (8) Switch, Oil              | (15) Assy Starter     |
| (2) Bolt, Flange                   | (9) Temperature Sensor Assay | (16) Gasket           |
| (3) Sensor, Crankshaft Wheel       | (10) Wire Harness 3          | (17) Flange Nut       |
| (4) Flange Bolt                    | (11) Assy Sensor, Tmap       | (18) With Washer Bolt |
| (5) Sensor, Knock                  | (12) Bolt, Flange            | (19) Flange Nut       |
| (6) Flange Bolt                    | (13) Assy Injection Harness  |                       |
| (7) Exhaust Gas Temperature Sensor | (14) Clamp, Cord             |                       |

## 6.21 EH5-G194001 ECU GROUP

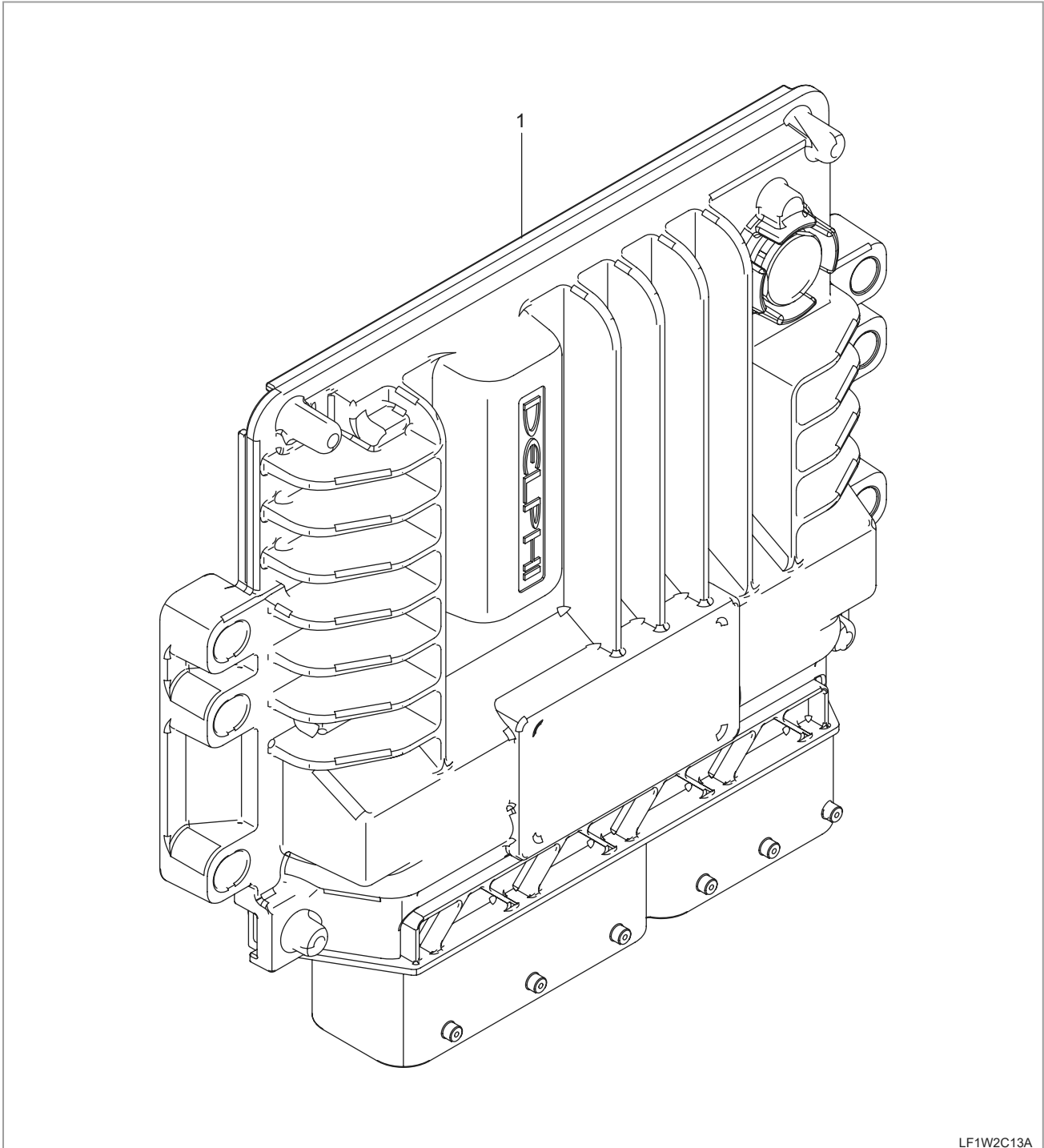
**COMPONENTS**

- (1) 050 - Controller, Engine

6.22 LF1-G012002 COOLING FAN GROUP

SAFETY FIRST

ENGINE

DRIVING & CHASSIS

HYDRAULIC SYSTEM

ELECTRIC SYSTEM

CABIN

INDEX

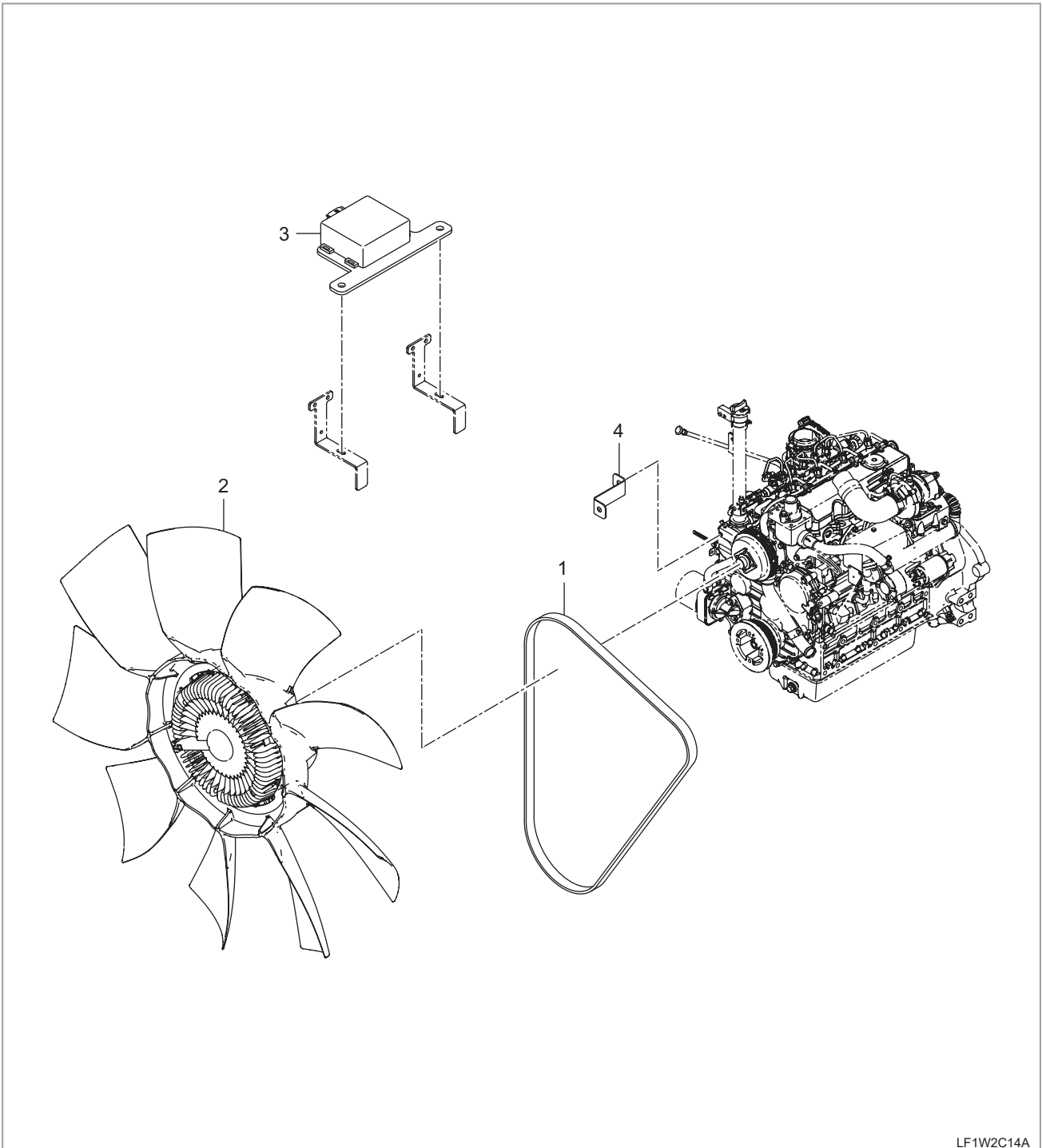

LF1W2C14A

COMPONENTS

- (1) Belt, Fan
- (2) Assy Fan, Clutch

- (3) Controller-Fan Clutch
- (4) Bracket

## 6.23 LF1-G014001 AFTERTREATMENT GROUP

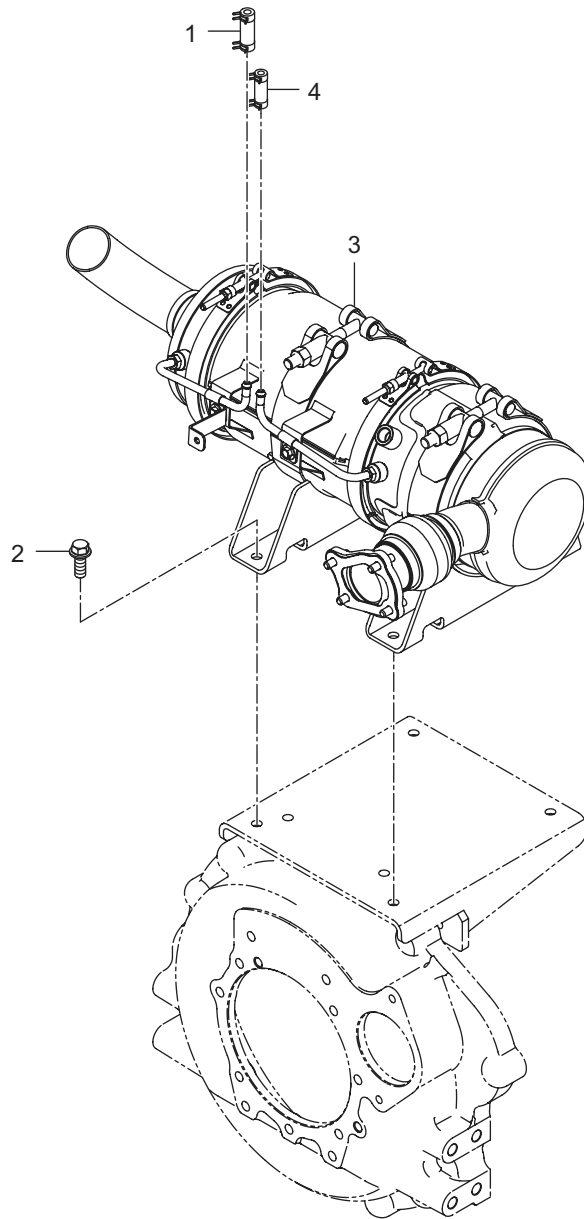

LF1W2C15A

**COMPONENTS**

- |                       |               |
|-----------------------|---------------|
| (1) Tube, 1           | (3) Assy Ccrt |
| (2) Bolt, With Washer | (4) Tube, 2   |

7. DISASSEMBLY, SERVICE AND ASSEMBLY

7.1 ENGINE REMOVAL

1. Park the vehicle on a flat surface, lower the boom lift onto the ground, turn off the engine, and then apply the parking brake.



2. After opening the engine compartment rear cover, turn off the battery power cut-off switch (1).
3. Remove the cabin. (Refer to "Cabin removal" in Chapter 6, Cabin.)

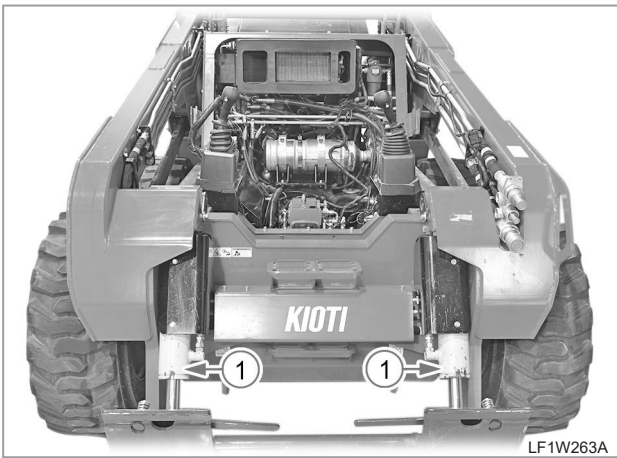

4. Remove the tilt cylinder (1).

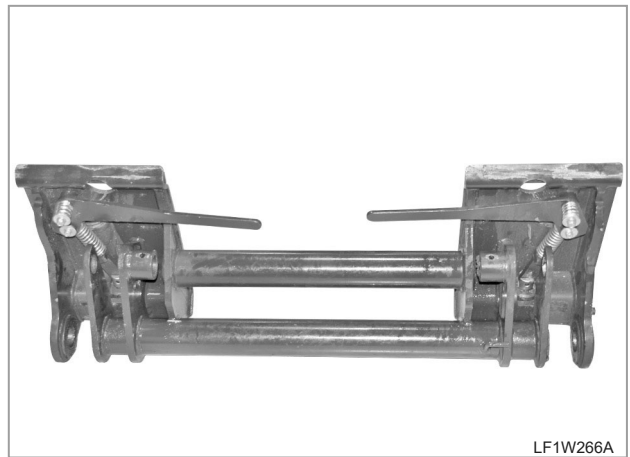
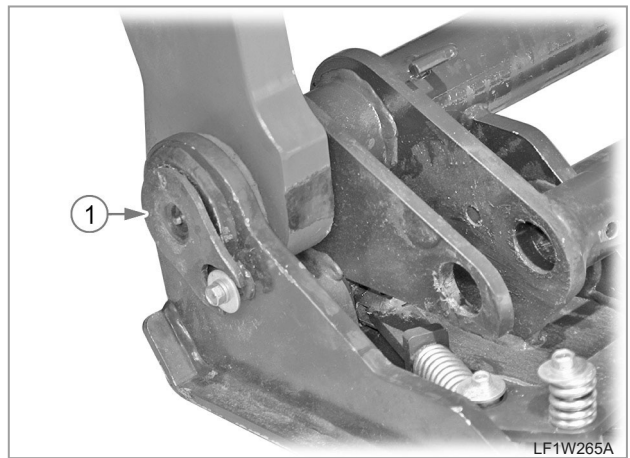
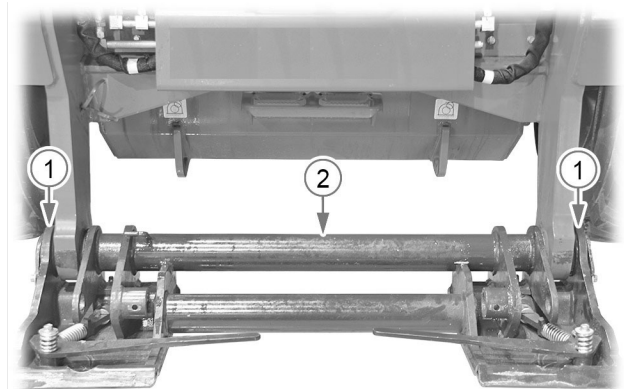

5. Pull out the bucket quick coupler retaining pins (1)(2EA). Then, remove the quick coupler (2).

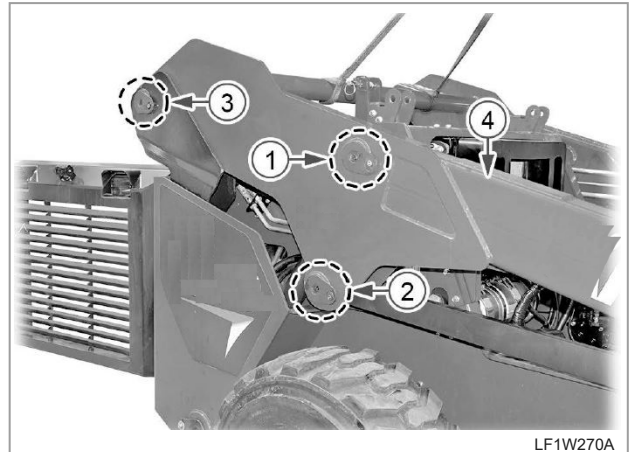
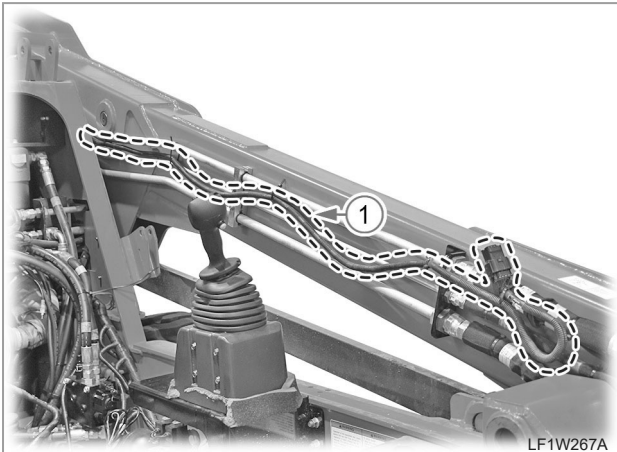

6. Disconnect the wiring (1) from the boom assembly.

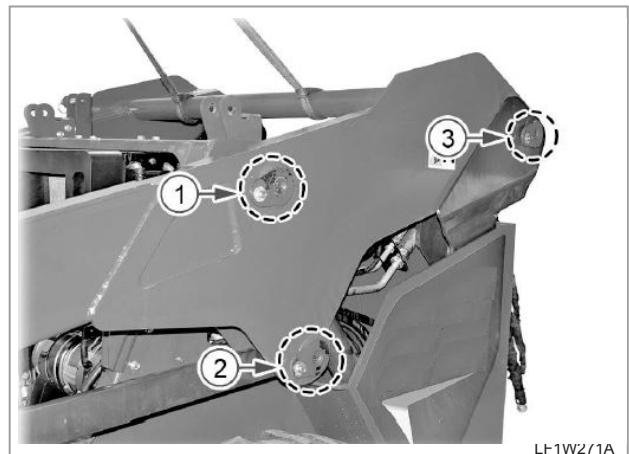
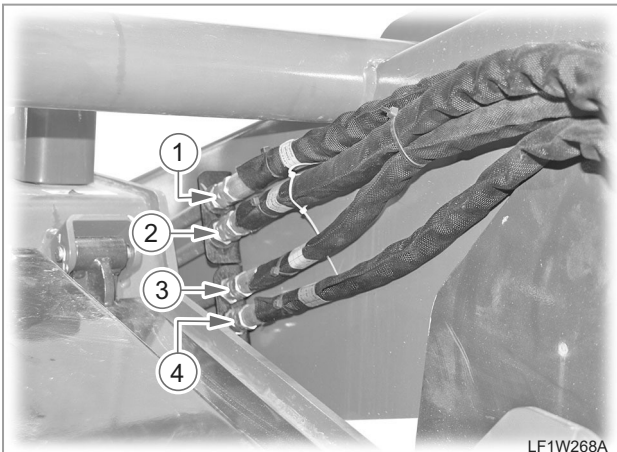

7. Disconnect the hydraulic hoses (1, 2, 3 (brown) & 4 (green)) from the right rear side of the boom assembly.

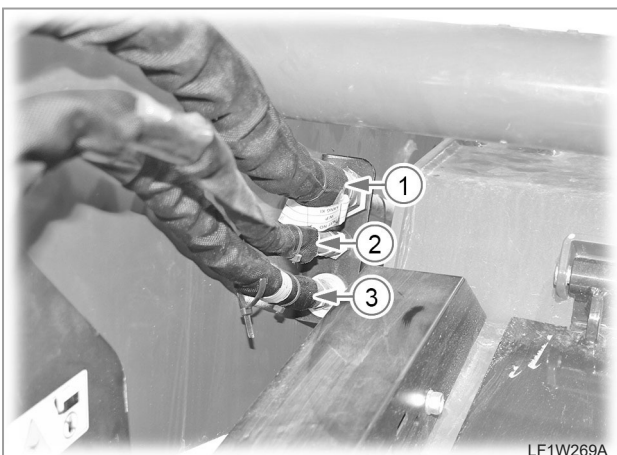
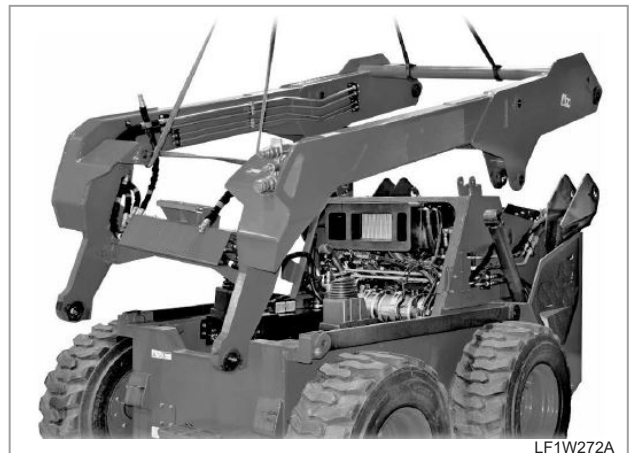

9. Support the boom with a hoist. Then, remove the lift cylinder retaining pins (1), boom auxiliary support pins (2) and boom retaining pins (3) to remove the boom assembly (4).

8. Disconnect the hydraulic hoses (1, 2 & 3 (brown)) from the left rear side of the boom assembly.

DISASSEMBLING THE MAIN PUMP

SAFETY FIRST

ENGINE

DRIVING & CHASSIS

HYDRAULIC SYSTEM

ELECTRIC SYSTEM

CABIN

INDEX

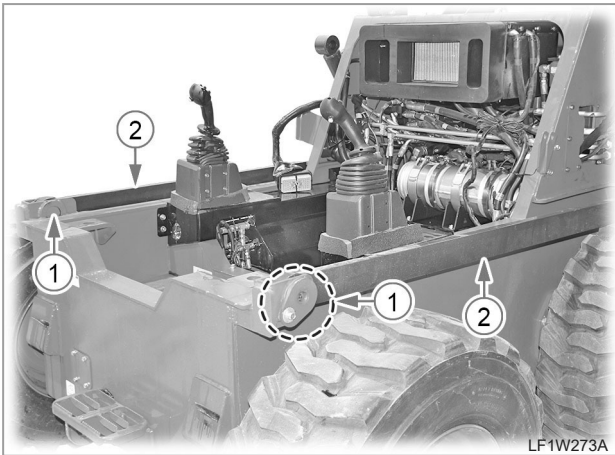

10. Pull out the boom support bar mounting pins (1) to remove the left-hand and right-hand boom support bars (2).

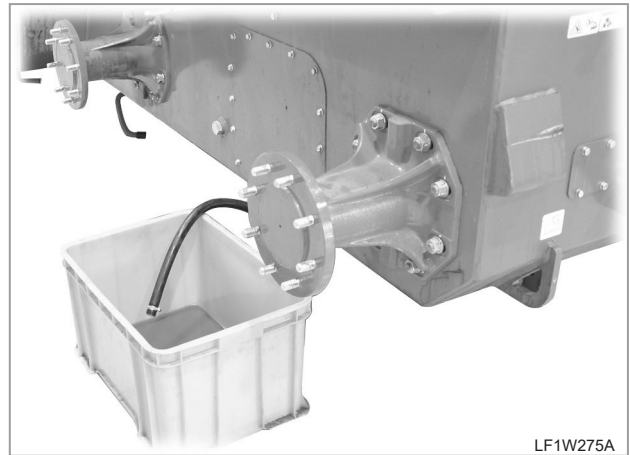

12. Drain the hydraulic oil from the oil tank.

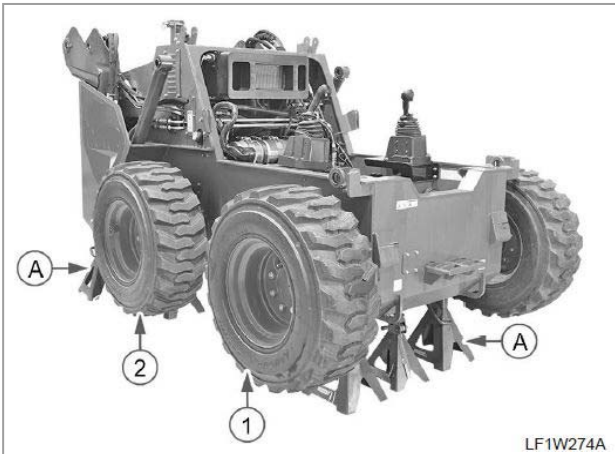

11. Place safety jacks (A) under the main frame firmly and remove the front and rear wheels.

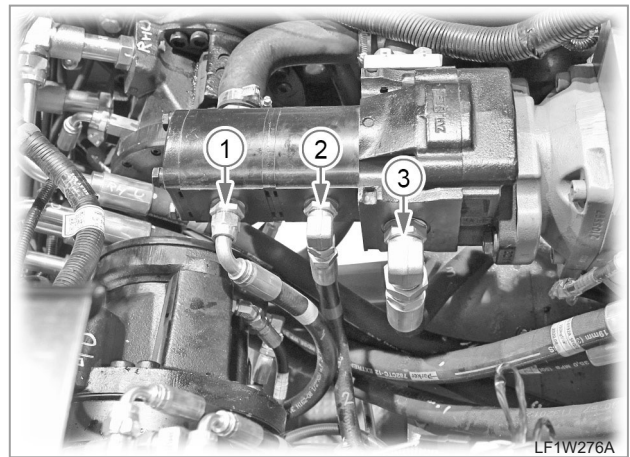

13. Disconnect the high-flow pump hydraulic hose (1), charge pump hydraulic hose (2) and main pump hydraulic hose (3).

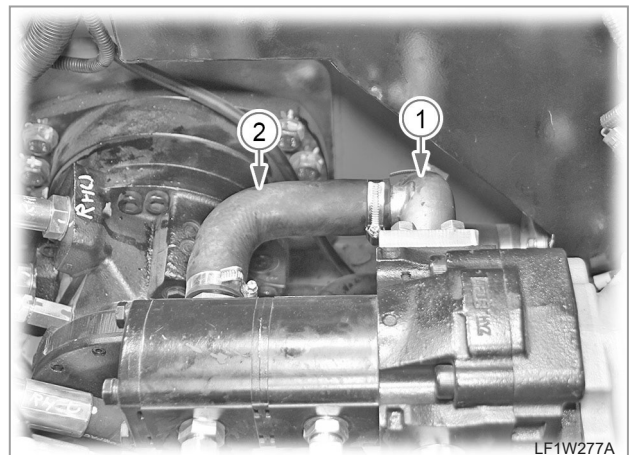

14. Disconnect the suction hose (1) from the main pump and the suction hose (2) from the high-flow pump.



**REMOVING THE A/C AND HEATER UNIT**

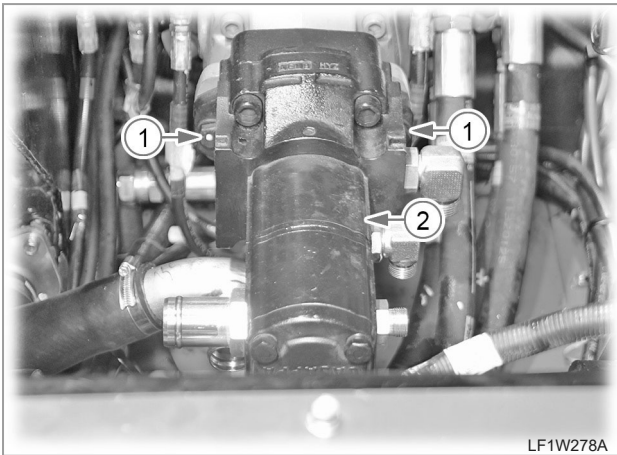

LF1W278A

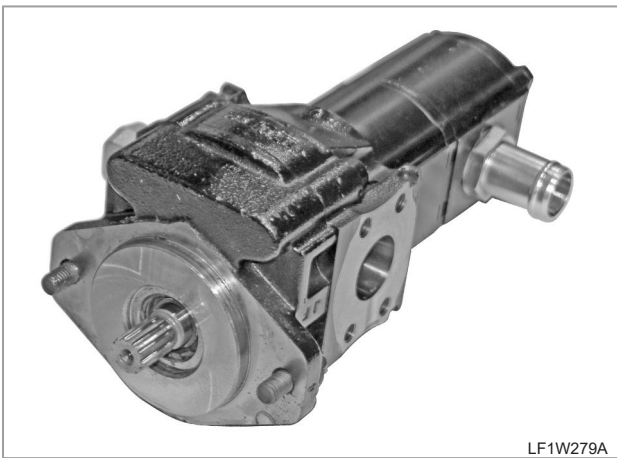

LF1W279A

15. Unscrew the main pump mounting bolts (1)(2EA) and remove the main pump assembly (2).

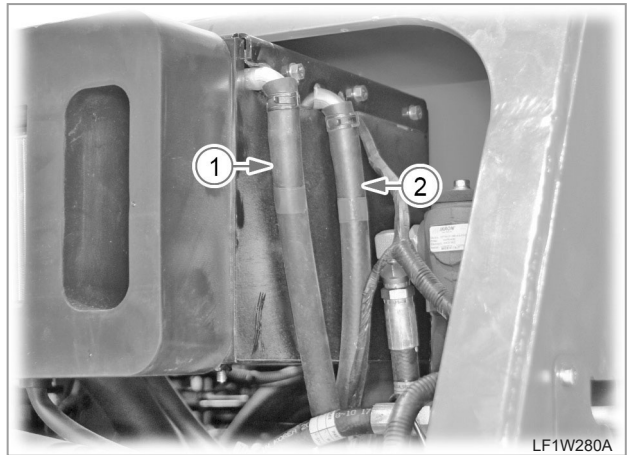

LF1W280A

16. Disconnect the heater hoses (1 & 2) from the heater unit.



LF1W281A

17. Disconnect the wiring connector (1).



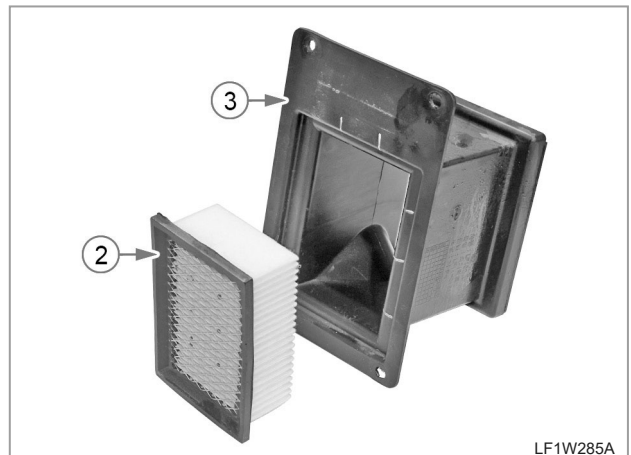
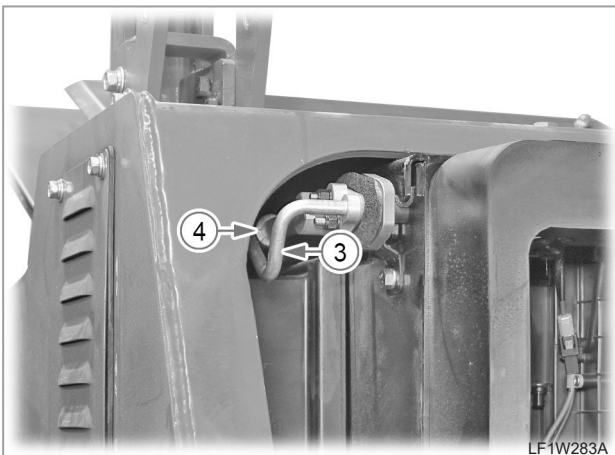
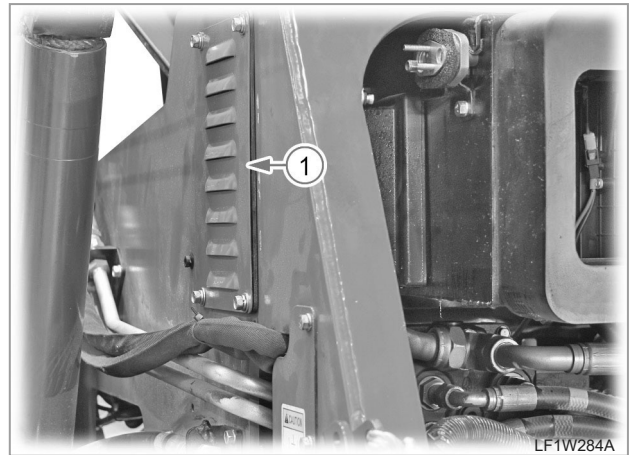
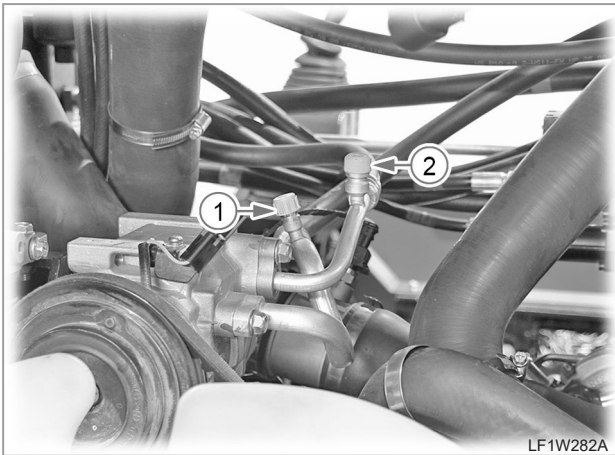

18. Install a refrigerant collector to the A/C hoses (1 & 2) and collect the refrigerant. Then, disconnect the A/C hoses (3 & 4).

19. Remove the air inlet cover (1). Then, detach the A/C filter (2) and duct (3).

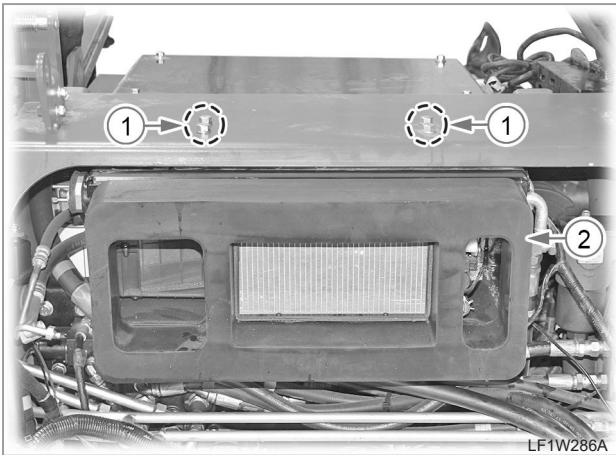

LF1W286A

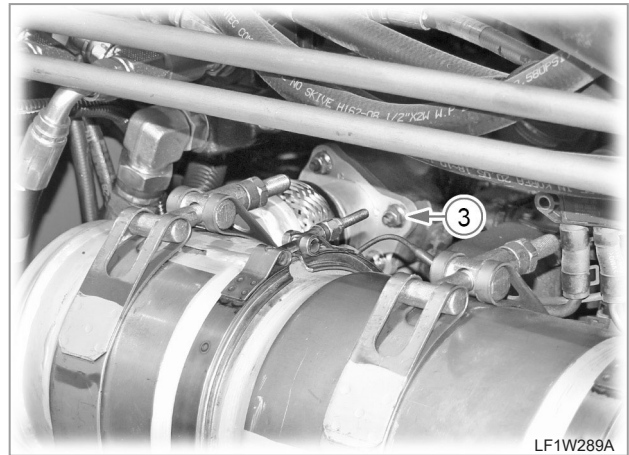

LF1W289A

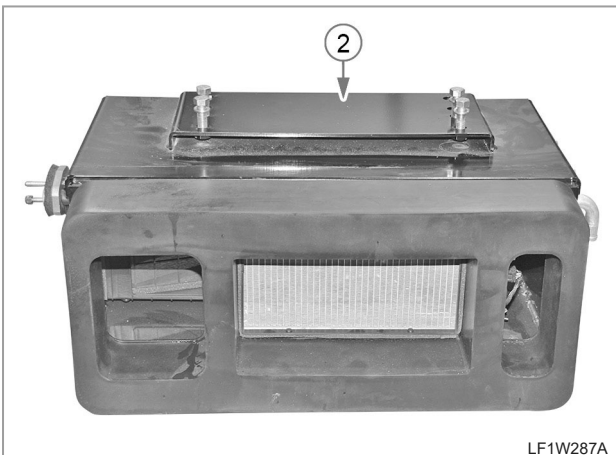

LF1W287A

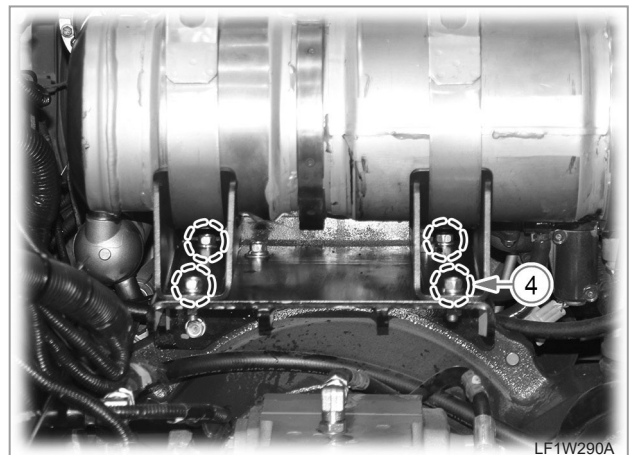

LF1W290A

20. Unscrew the A/C and heater unit assembly mounting bolts (1)(4EA) on the main frame, and remove the A/C and heater unit assembly (2).

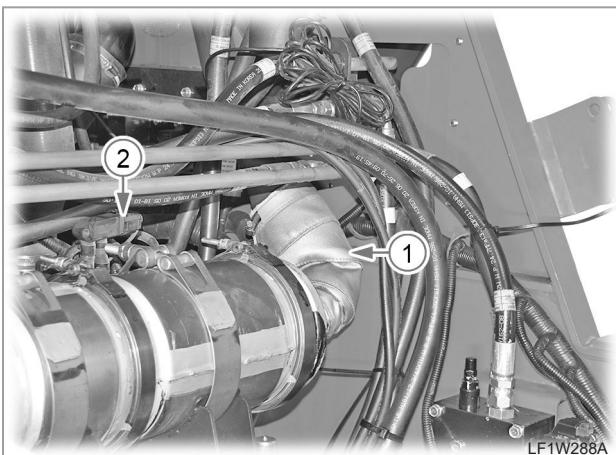

LF1W288A

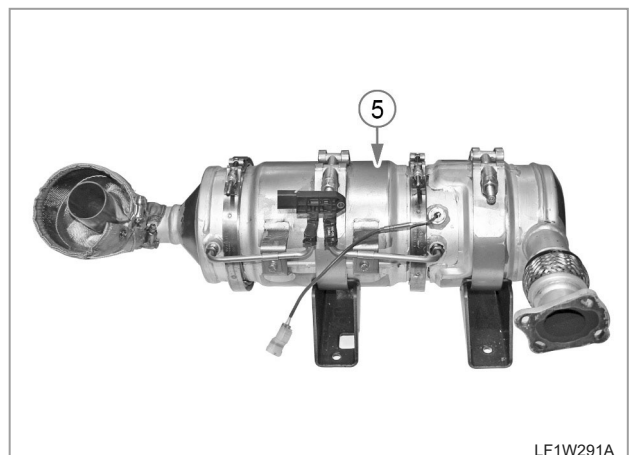

LF1W291A

21. After removing the DPF heat shield cover (1) and disconnecting the sensor connector (2), unscrew the DPF connecting nuts (3)(4EA) (turbocharger) and DPF bracket mounting bolts (4)(4EA) to remove the DPF assembly (5).

**REAR BODY SECTION**

22. Open the rear door of the engine compartment.

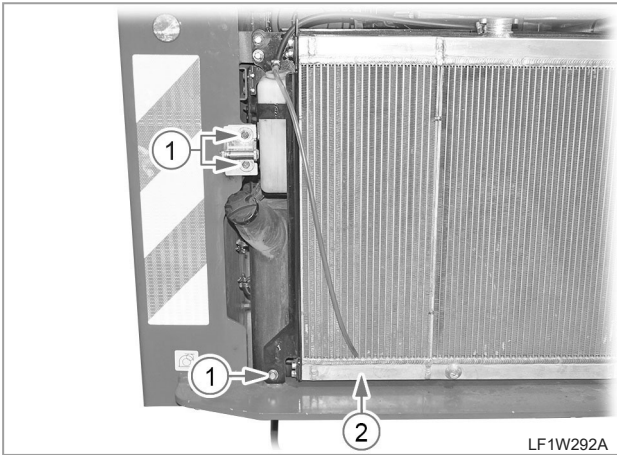

23. Unscrew the radiator mounting bolts (1)(3EA) and open the radiator (2).

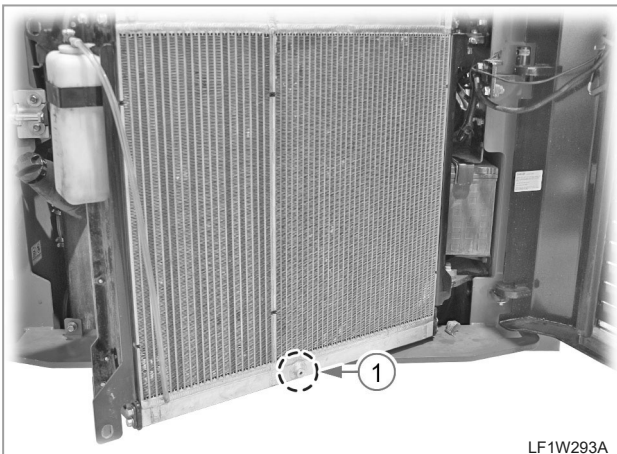

24. Unscrew the radiator drain plug (1) to drain the coolant.

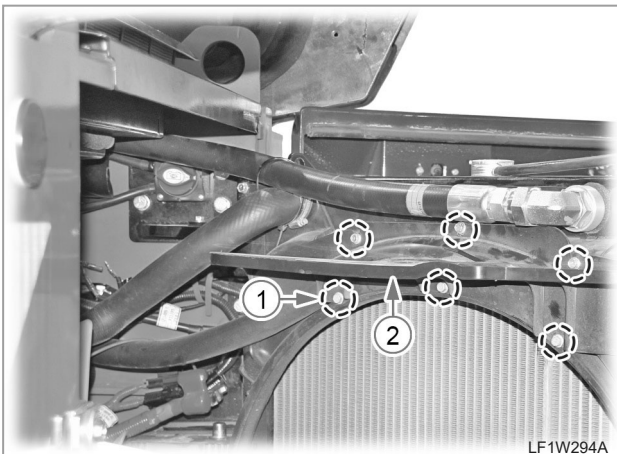

25. Unscrew the oil cooler hose cover mounting bolts (1)(6EA) and remove the oil cooler hose cover (2).

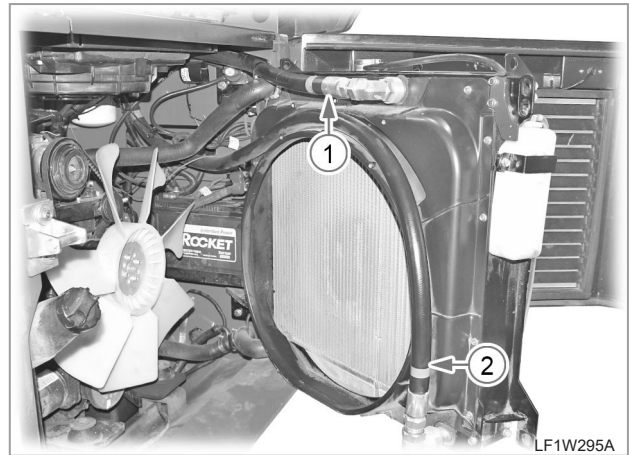

26. Disconnect the oil cooler hoses (1 & 2) from the oil cooler.

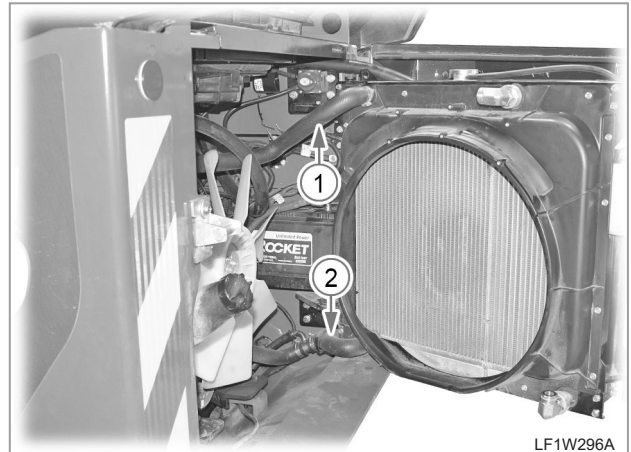

27. Disconnect the hoses (upper: 1, lower: 2) from the radiator.



28. Remove the battery power cut-off switch (1).

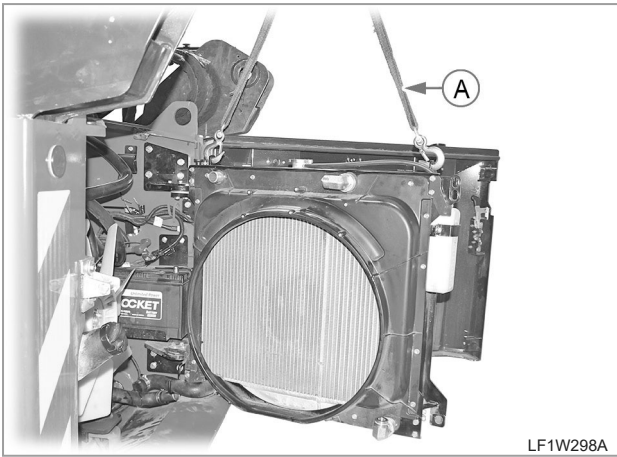

LF1W298A

29. Install the disassembly jig (A) on the radiator and hang it with a hoist.

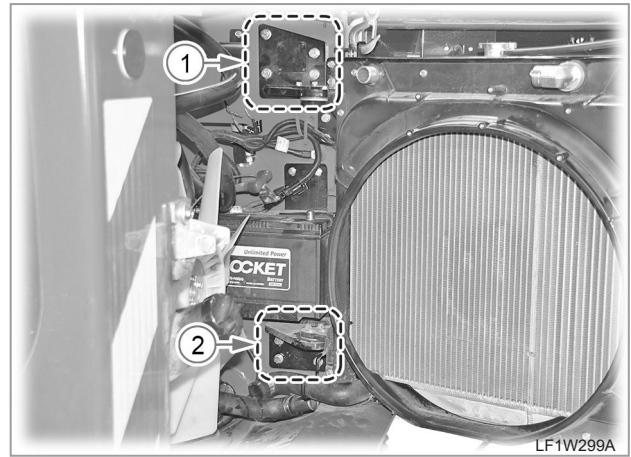

LF1W299A

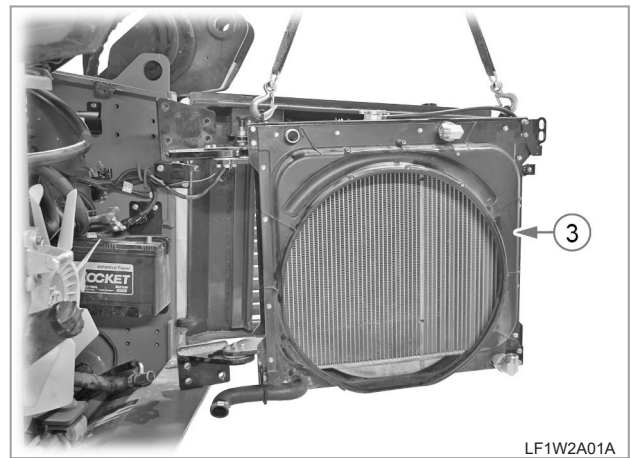

LF1W2A01A



LF1W2A02A

30. Detach the radiator mounting brackets (1 & 2) to remove the radiator.

**DISASSEMBLING THE CONDENSER AND INTERCOOLER**

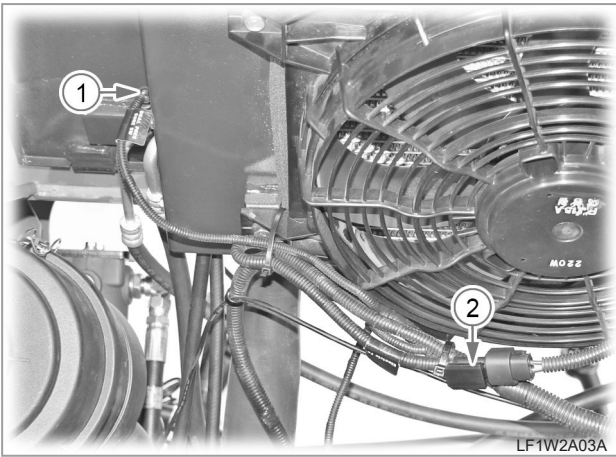

31. Disconnect the A/C condenser pressure switch connector (1) and fan motor connector (2).

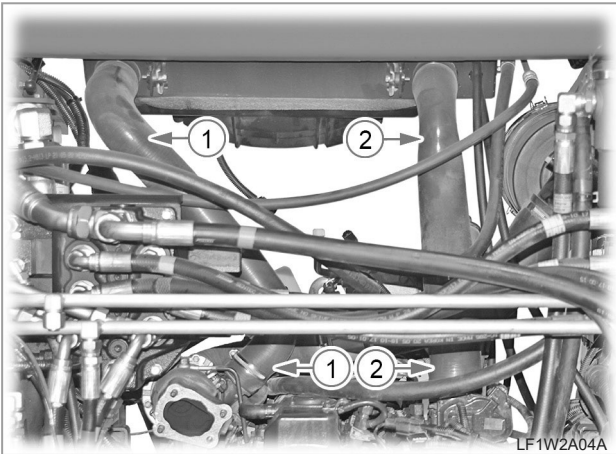
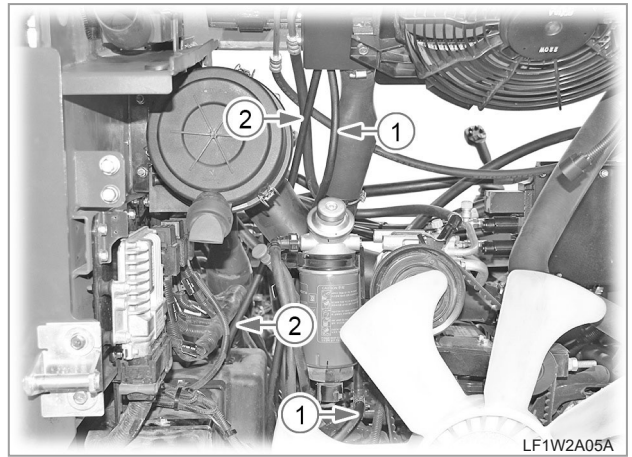

32. Disconnect the intercooler hoses (1 & 2).

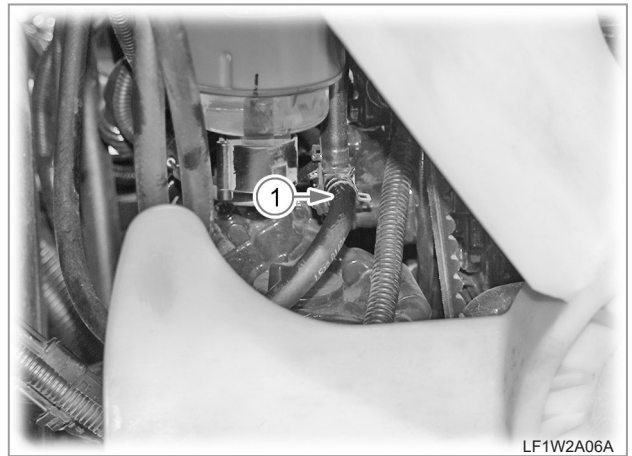

33. Disconnect the fuel cooler hoses (1 & 2).



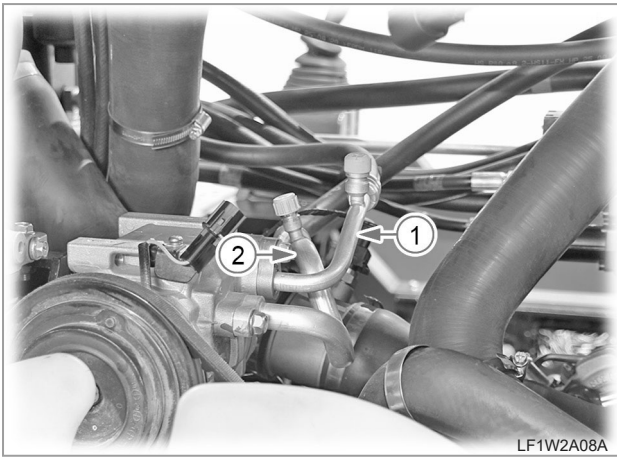

LF1W2A08A

34. Disconnect the A/C hoses (1: high-pressure, 2: low-pressure) from the compressor.

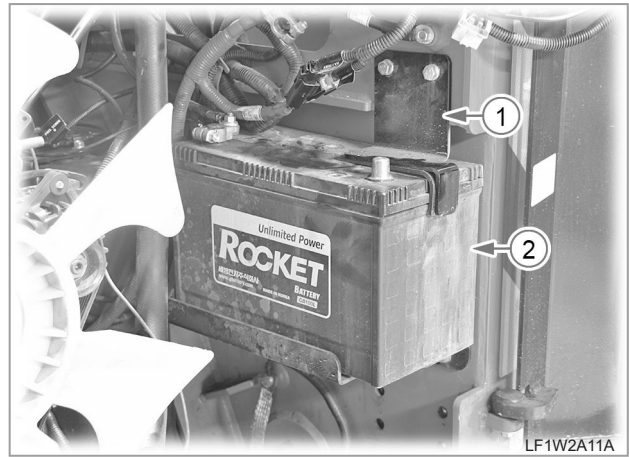

LF1W2A11A

37. Remove the battery bracket (1) to remove the battery (2).

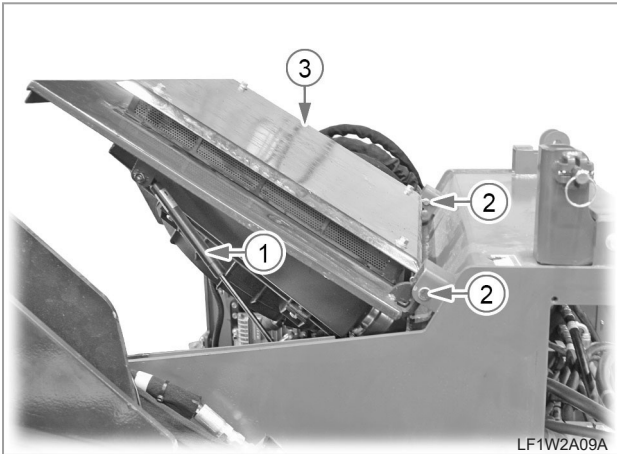

LF1W2A09A

35. After removing the air cylinders (1) and condenser assembly connecting pins (2), remove the condenser, intercooler, and fuel cooler assembly (3).

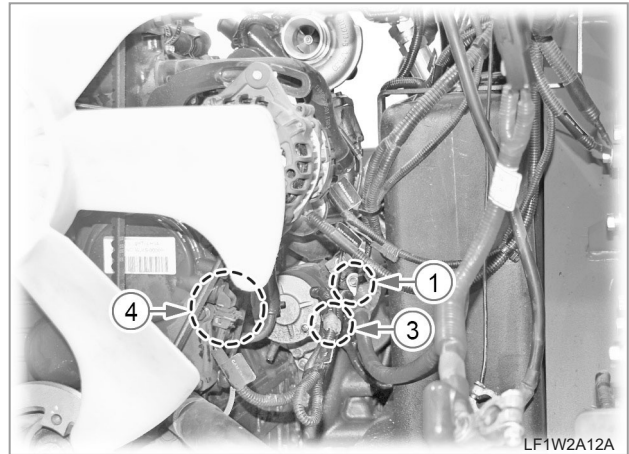

LF1W2A12A

38. Disconnect the start motor wiring connector (1), alternator wiring connector (2), exhaust temperature sensor connector (3) and camshaft wheel sensor connector (4).

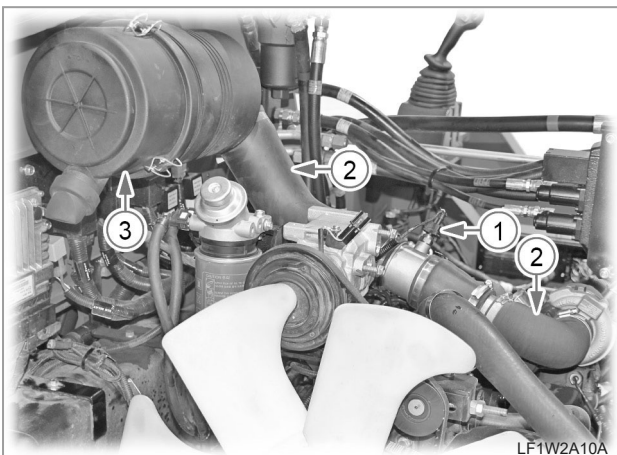

LF1W2A10A

36. Disconnect the intake temperature sensor (T1) connector (1) and then remove the air cleaner hose (2) and air cleaner (3).

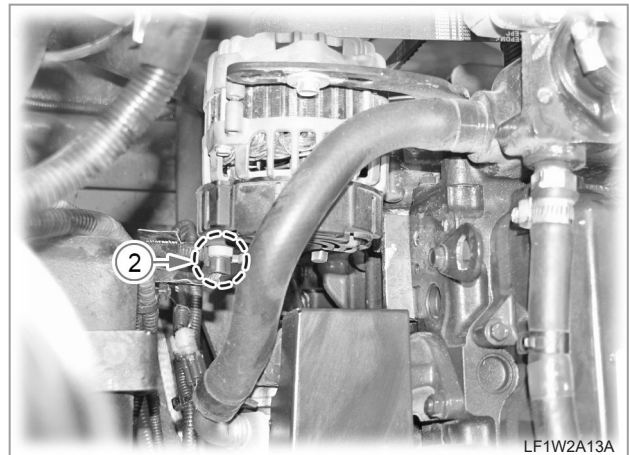

LF1W2A13A



39. Disconnect the engine wiring connector (1) from the front left side of the engine.

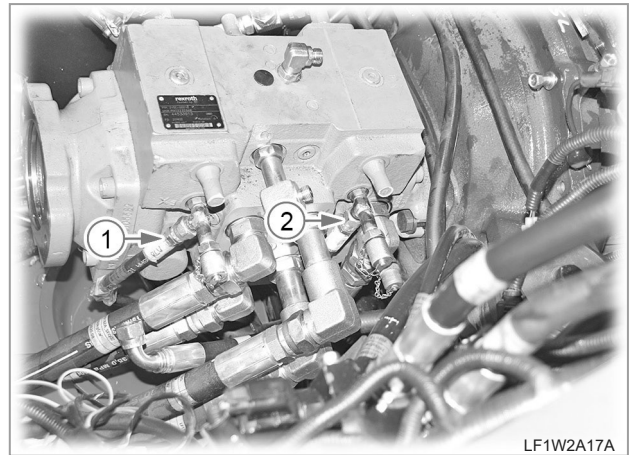

42. Disconnect the RCV (LH) (reverse driving-RH) hose (1) and RCV (LH) (reverse driving-LH) hose (2).

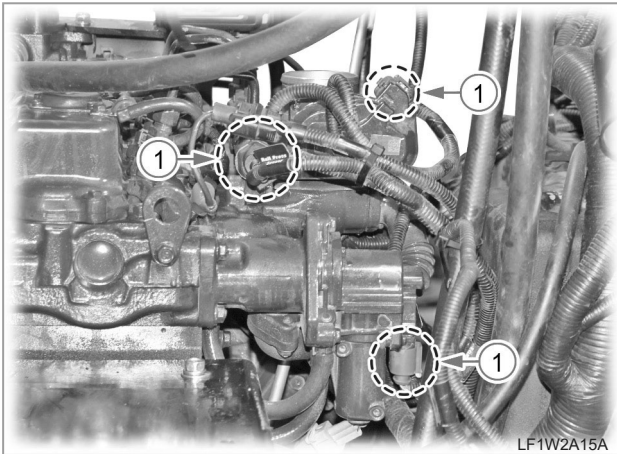

40. Disconnect the various engine sensor connectors (1) from the rear side of the engine.

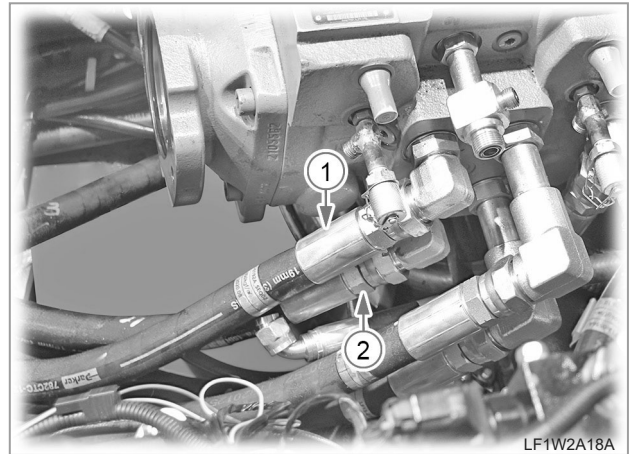

43. Disconnect the HST motor (RH) (reverse driving) hose (1) and HST motor (RH) (forward driving) hose (2).

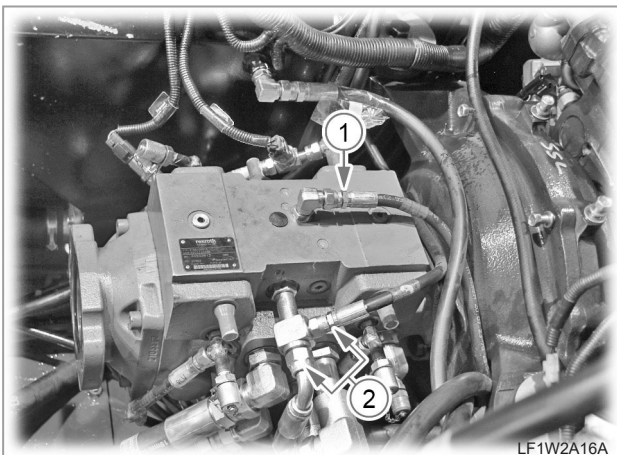

41. Disconnect the pilot lock valve hose (1) from the top of the HST pump and the HST filter hose (2) from the left side of the HST pump.

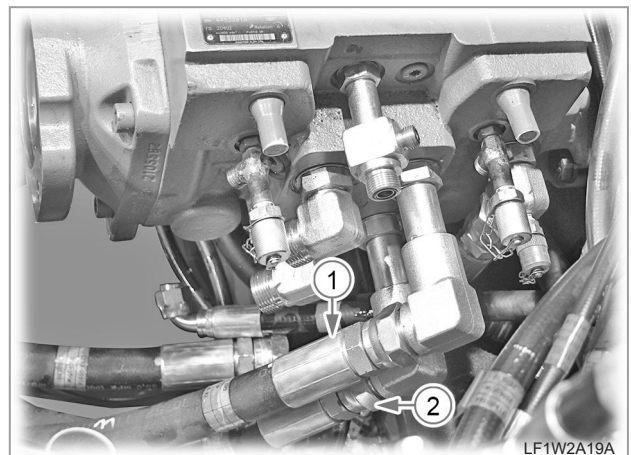

44. Disconnect the HST motor (LH) (reverse driving) hose (1) and HST motor (LH) (forward driving) hose (2).

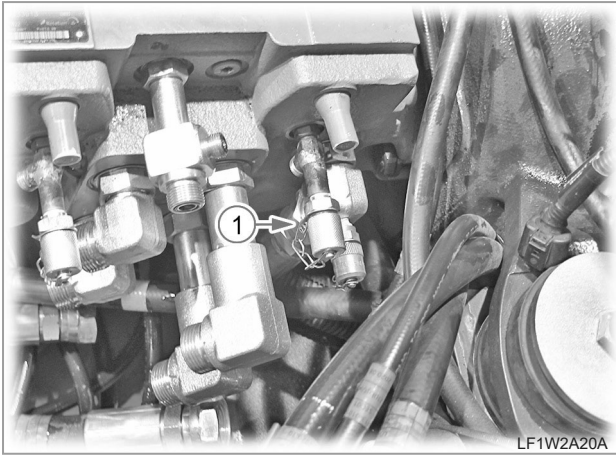

45. Disconnect the oil tank hose (1).

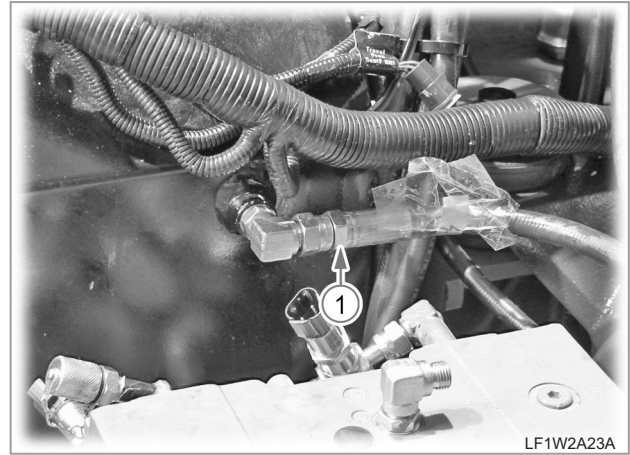

48. Disconnect the oil pressure tank hose (1).

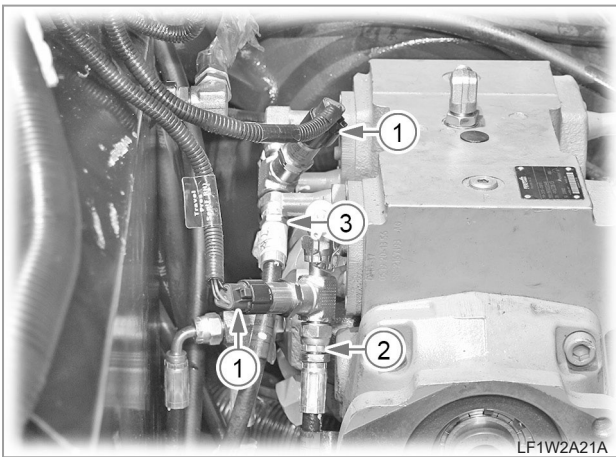

46. Disconnect each driving pressure sensor connector (1) from the RCV (LH) hydraulic hoses. Then, disconnect the RCV (LH) (forward driving-RH) hydraulic hose (2) and RCV (LH) (forward driving-LH) hydraulic hose (3).

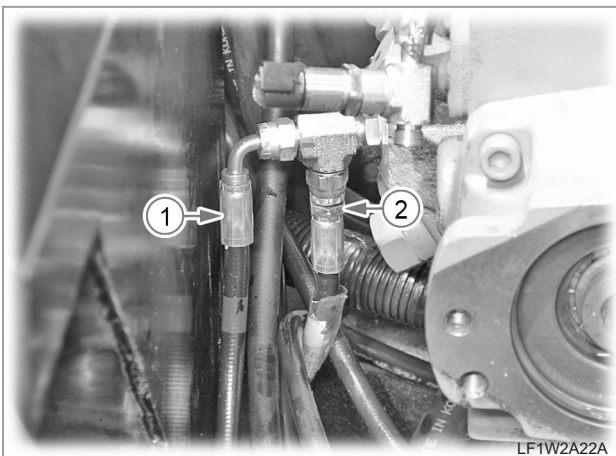

47. Disconnect the soft shift valve hose (1) and parking valve hose (2).



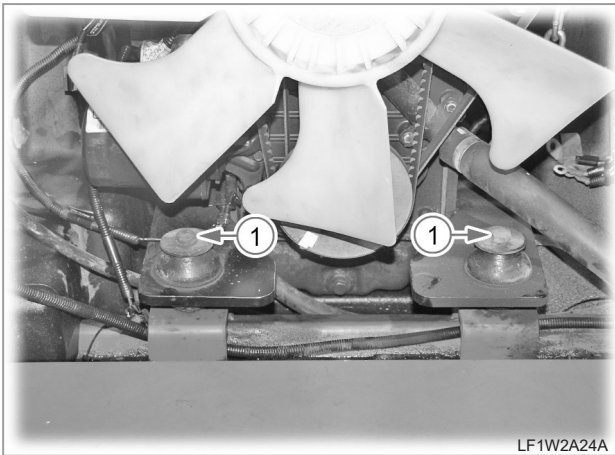

LF1W2A24A

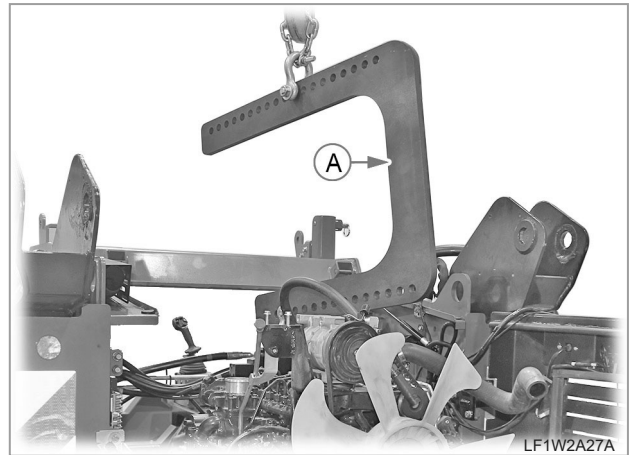

LF1W2A27A

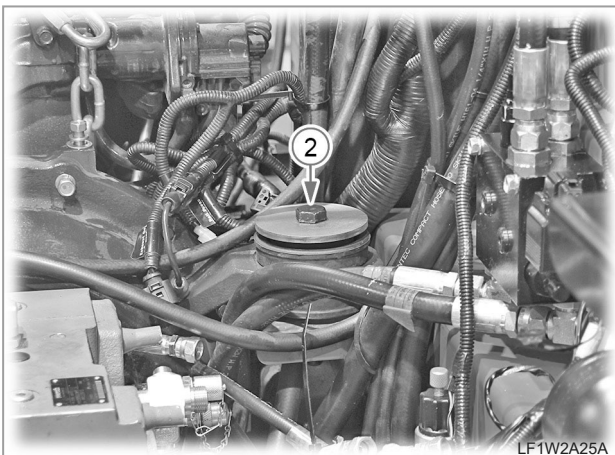

LF1W2A25A

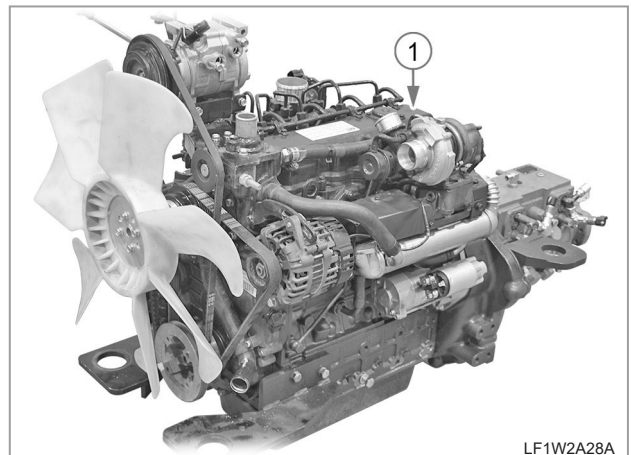

LF1W2A28A

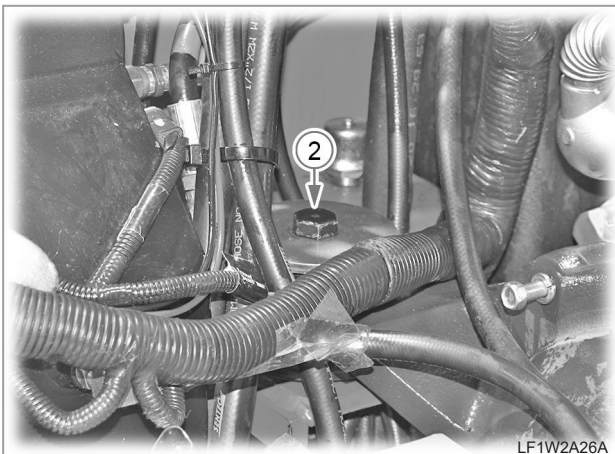

LF1W2A26A

49. Loosen the two front engine mounting bolts (1) and two rear engine mounting bolts (2).

50. Install a disassembly jig (A) on the engine and use a hoist to pull out and put aside the engine/HST pump assembly (1) safely.

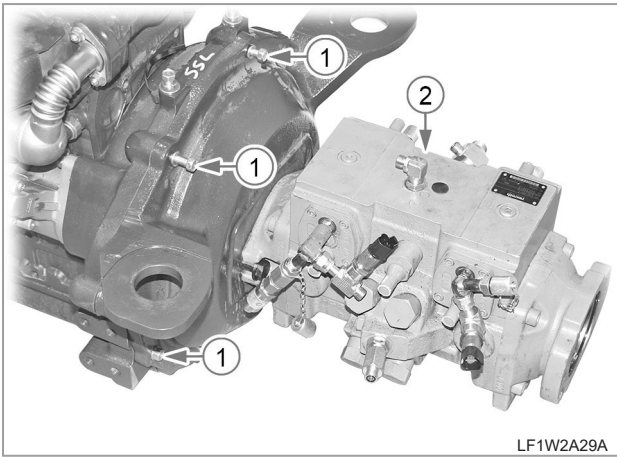

LF1W2A29A

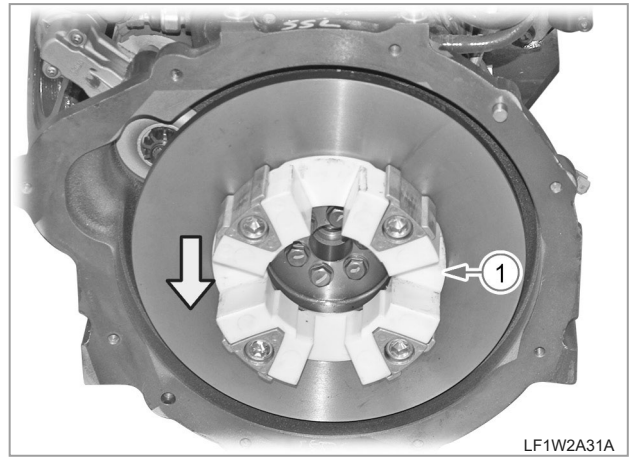

LF1W2A31A

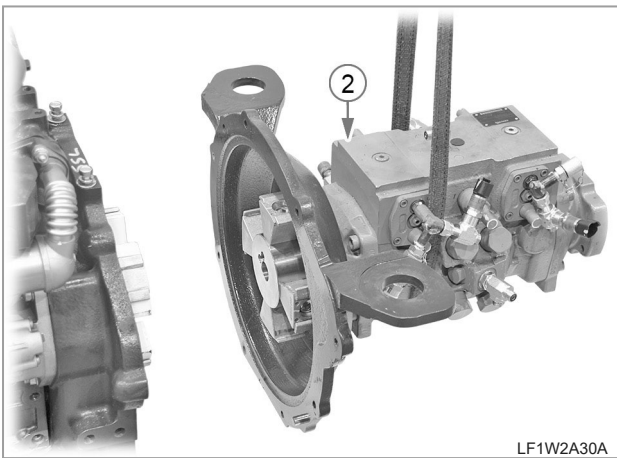

LF1W2A30A



LF1W2A32A

51. Unscrew the 7 housing mounting bolts (1) on the engine/HST pump assembly to remove the HST pump assembly (2).

52. Remove the coupling element (1) from the flywheel.

**REMARKS**

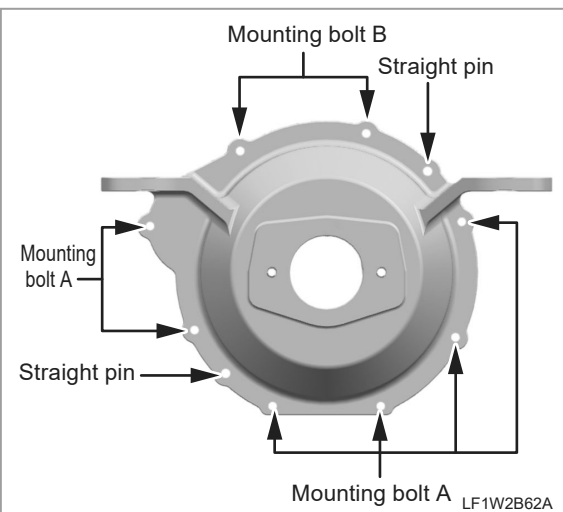

LF1W2B62A

- When combining the engine and pump housing, be careful not to miss the straight pin. Ensure to also tighten the mounting bolts A & B sequentially in a diagonal order.
- Mounting bolts (A, B)(M10) tightening torque ..... 4.9 ~ 5.7 kgf-m

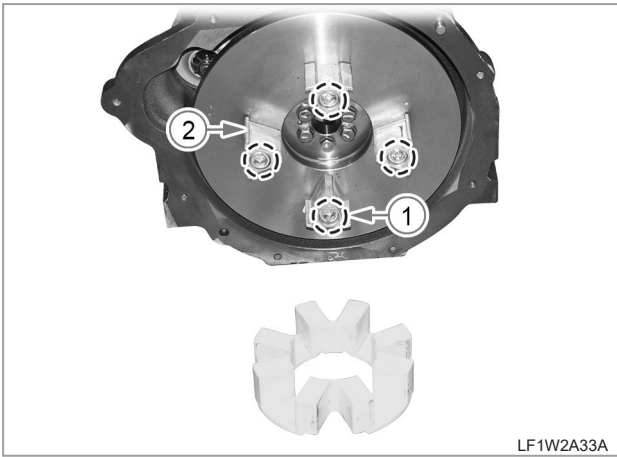

LF1W2A33A

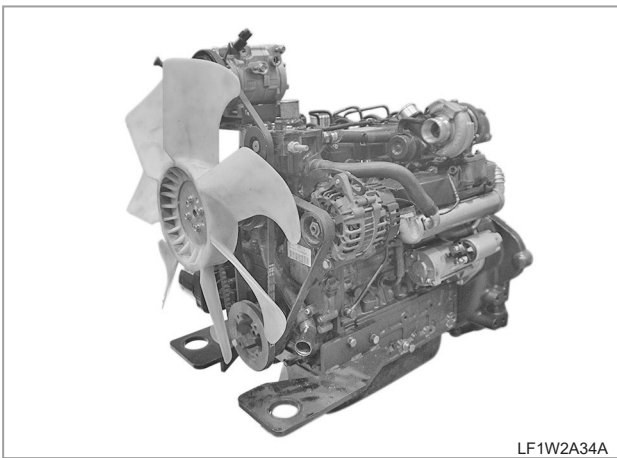

LF1W2A34A

REMARKS

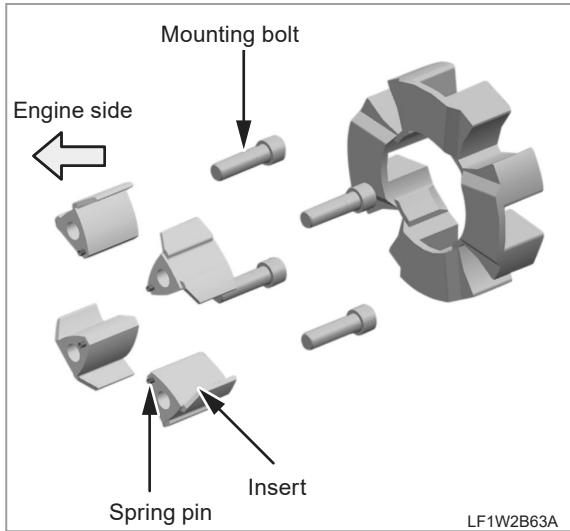

LF1W2B63A

- When installing the coupling assembly, install its halves on the engine side and pump housing side separately, and then combine them together.
- When installing the inserts on the engine flywheel, be careful not to miss their spring pins and tighten the mounting bolts to the specified torque.
- Mounting bolt  
tightening torque ..... 21 ~ 23 kgf-m

53. Loosen the insert mounting bolts (1) on the flywheel and remove the inserts (2)(4EA).

## 7.2 ASSEMBLING THE ENGINE

SAFETY FIRST

ENGINE

DRIVING &amp; CHASSIS

HYDRAULIC SYSTEM

ELECTRIC SYSTEM

CABIN

INDEX

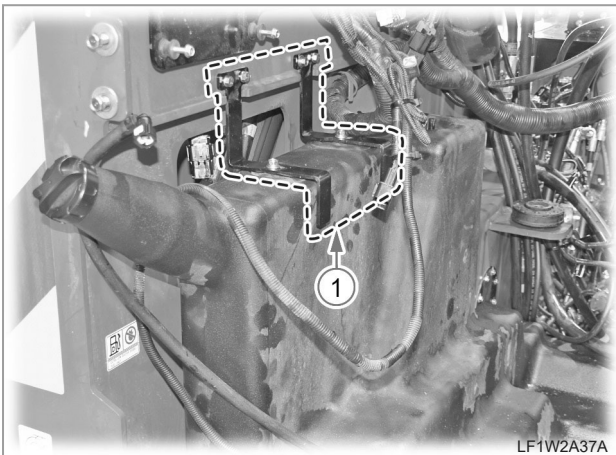
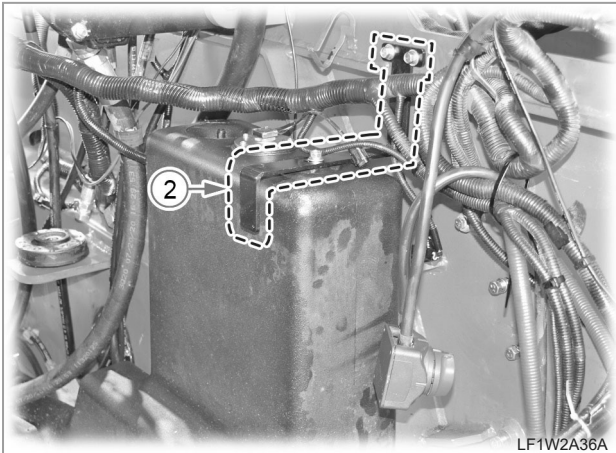
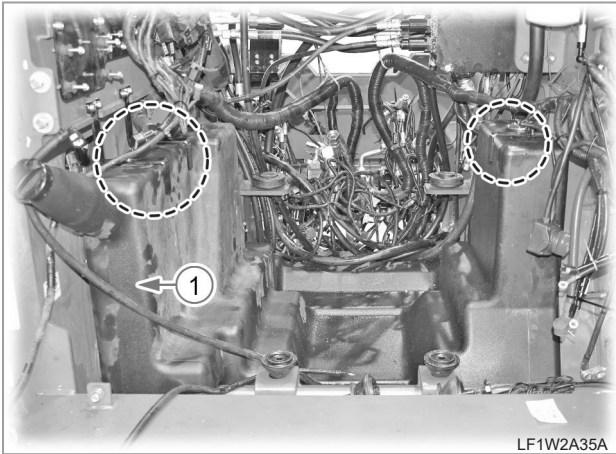

1. Place the fuel tank (1) on the main frame and fix it using the support brackets (2)(3EA).

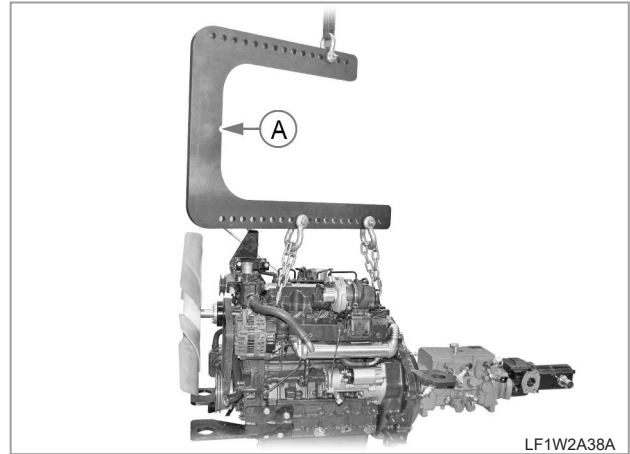

2. Install the specified jig (A) on the engine/HST pump assembly and hang it on a hoist.

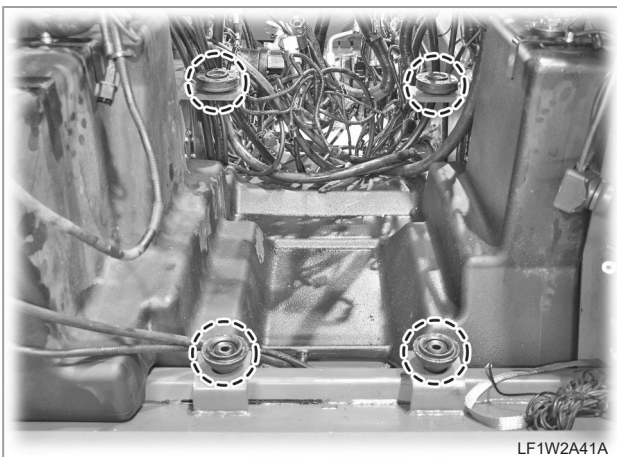
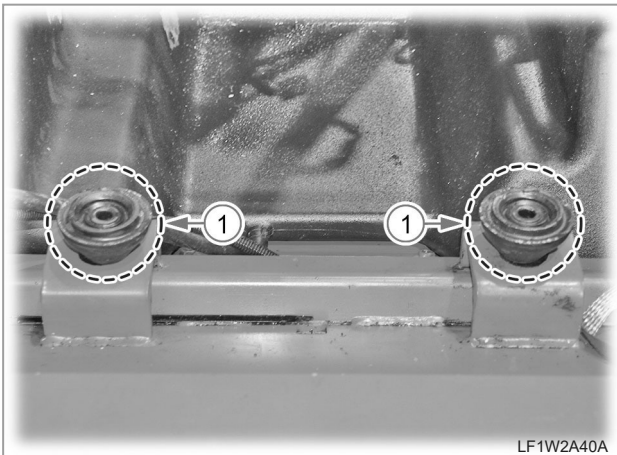
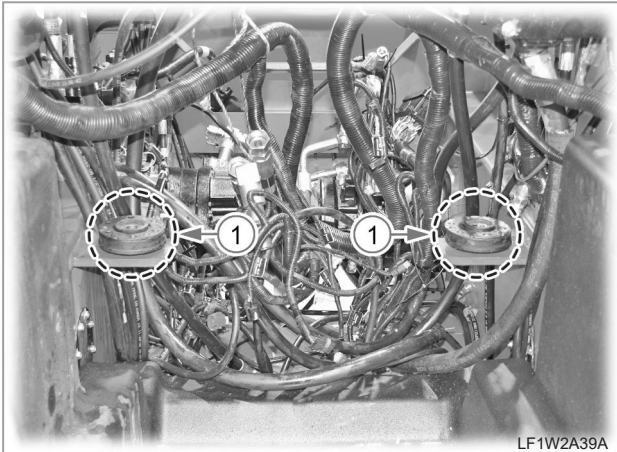

3. Install the engine mounting rubbers (1) on the front and rear sections of the main frame.

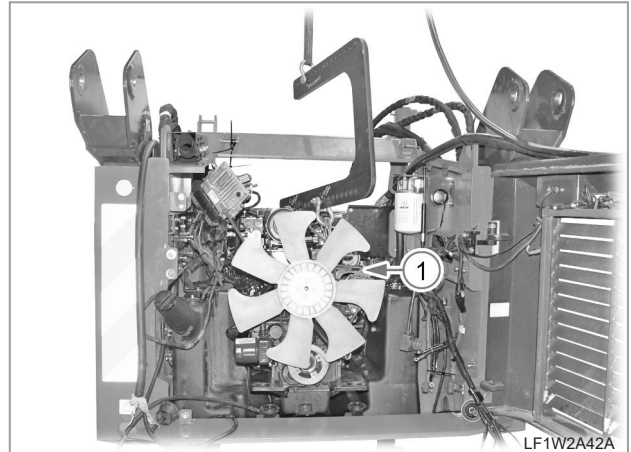

4. Using a hoist, lift the engine assembly (1), move it into the main frame, and place it on the engine mounting section.

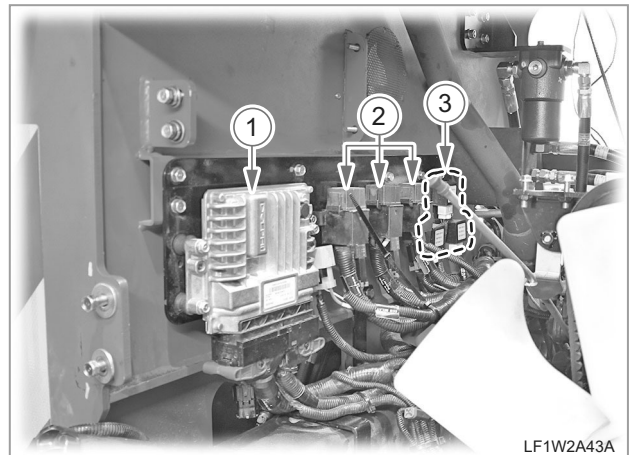

5. Install the engine ECU (1), fuses (2) and relays (3).

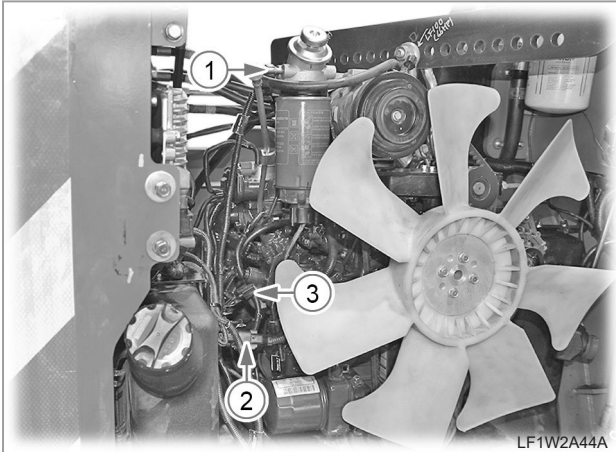

LF1W2A44A

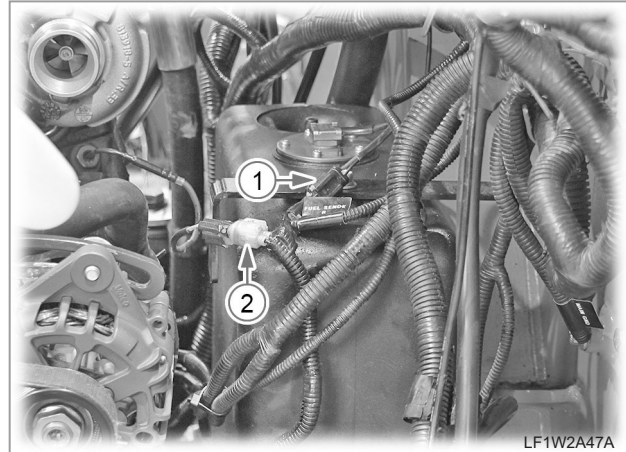

LF1W2A47A

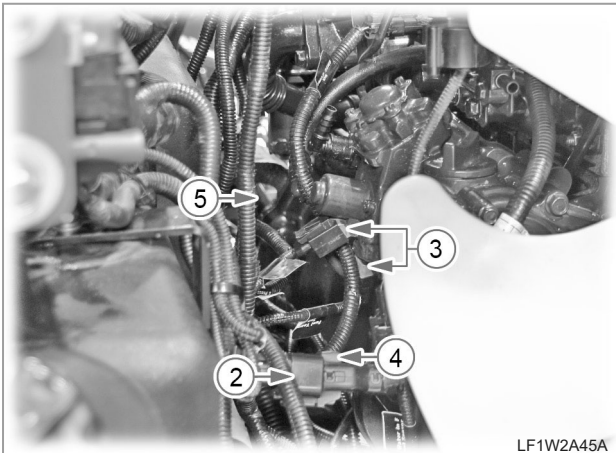

LF1W2A45A

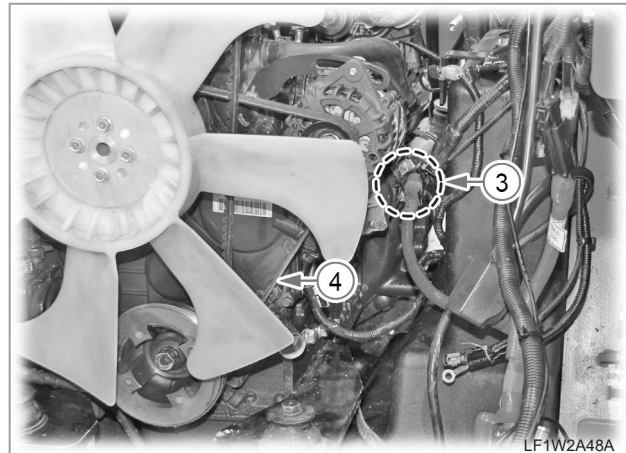

LF1W2A48A

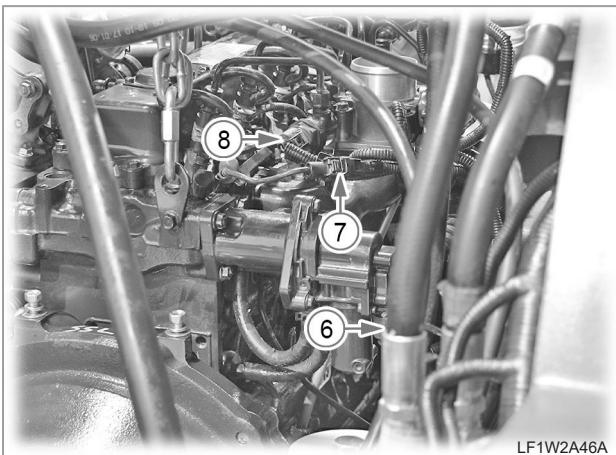

LF1W2A46A

6. Connect the connectors for the fuel heater (1), engine injector wiring (2), high-pressure fuel pump (3), knock sensor (4), crank wheel sensor (5), EGR sensor (6), glow plug sensor (7), and common rail pressure sensor (8) on the right side of the engine.

7. Connect the connectors for the fuel sender (1), exhaust temperature (2), start motor (3), and camshaft wheel sensor (4) on the left side of the engine.



INSTALLING THE HST PUMP CONNECTING HOSE

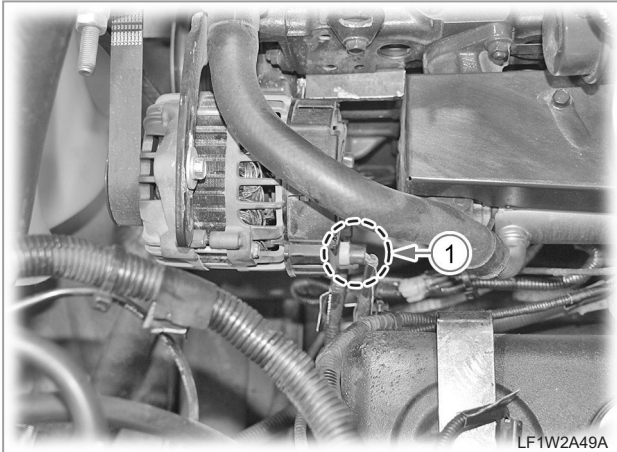

8. Install the alternator wiring (1).

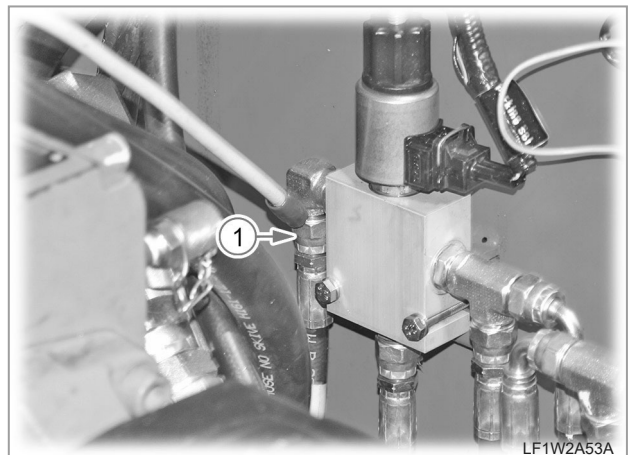
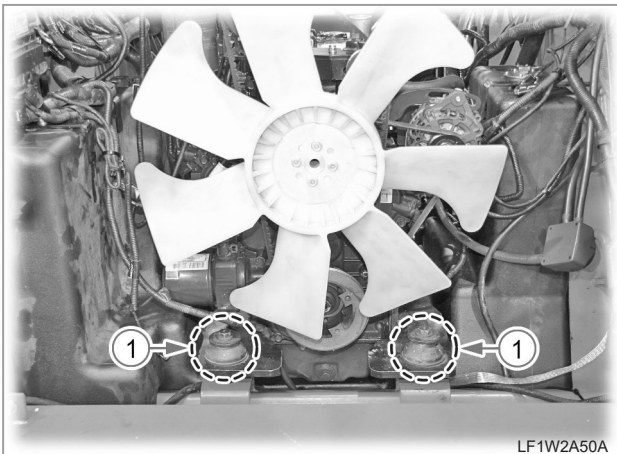
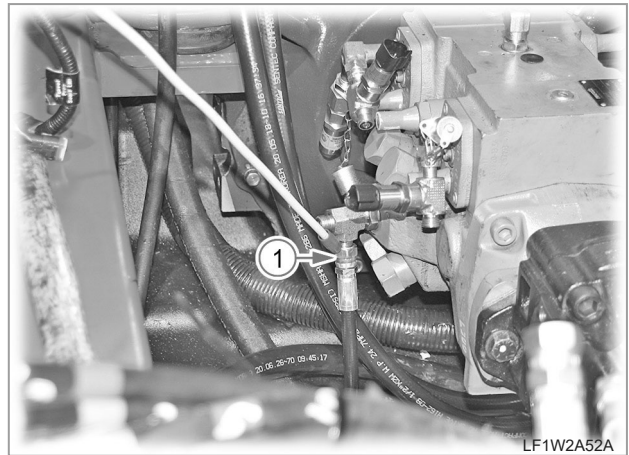

10. Connect the HST pump and parking valve with the hydraulic hose (1) on the right side of the HST pump.

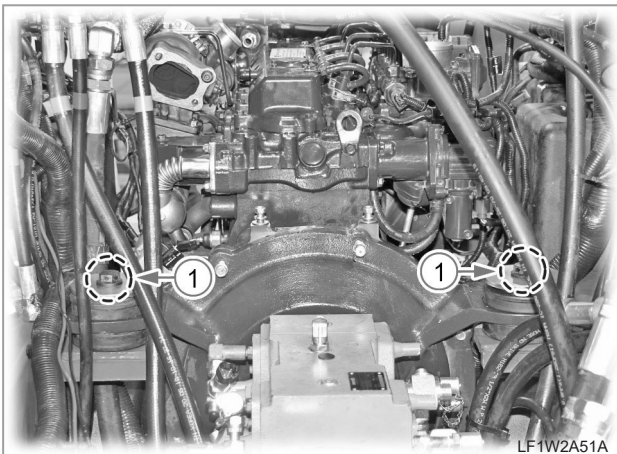

9. After removing the engine assembly jig, tighten the engine mounting bolts (1)(4EA).

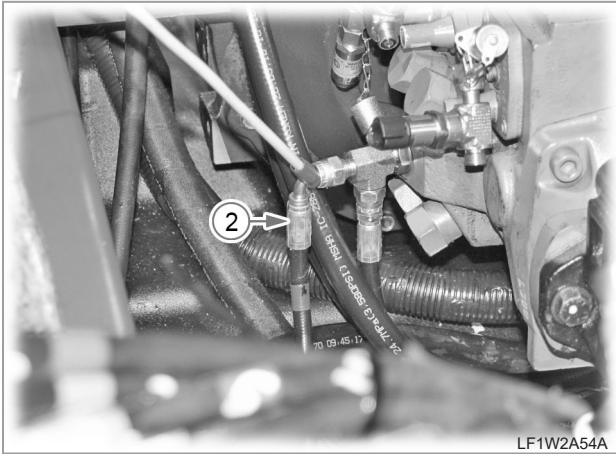

LF1W2A54A

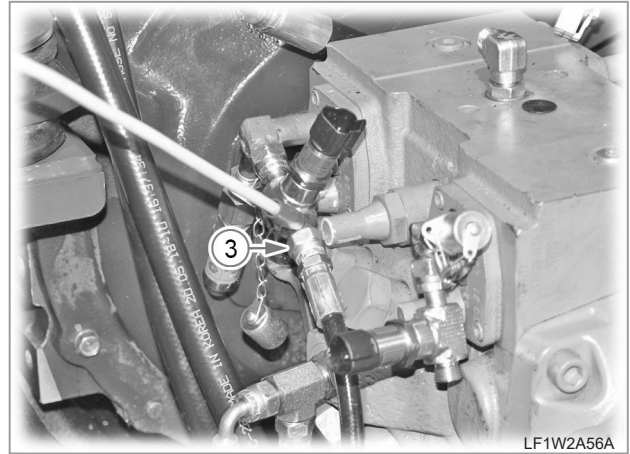

LF1W2A56A

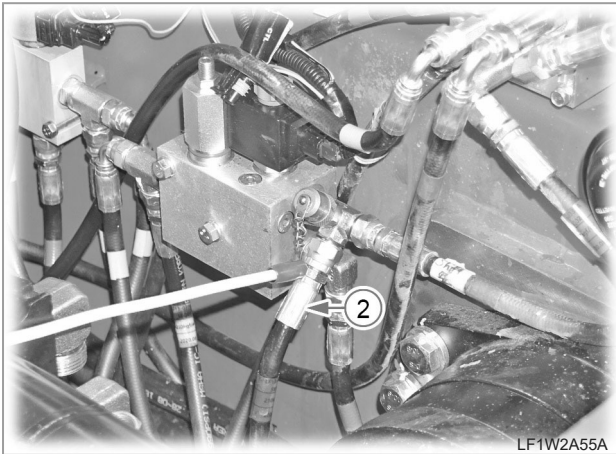

LF1W2A55A

11. Connect the HST pump and pilot lock valve with the hydraulic hose (2).

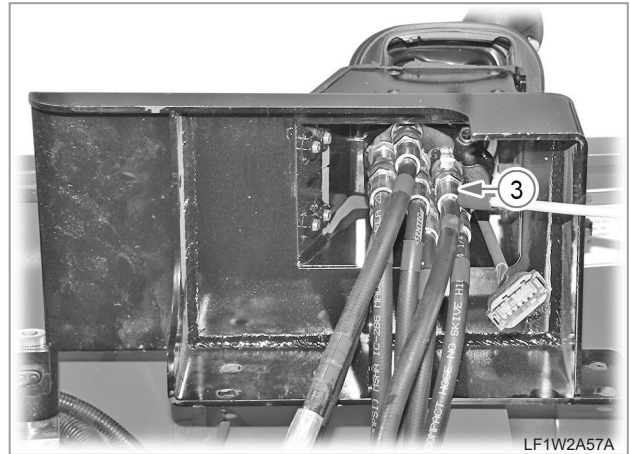

LF1W2A57A

12. Connect the hydraulic hose (3) from the HST pump to the left-hand RCV (forward driving-LH).



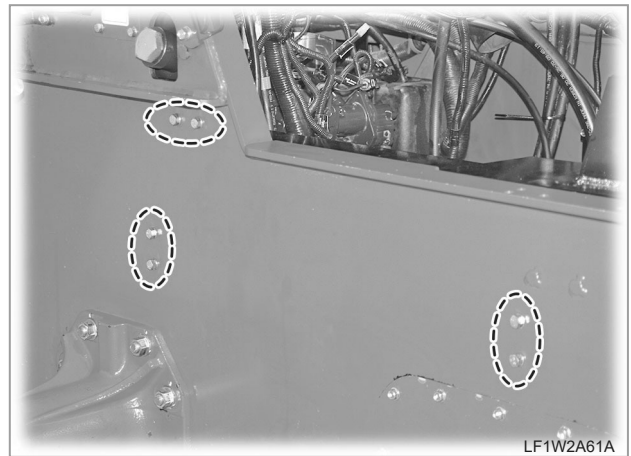
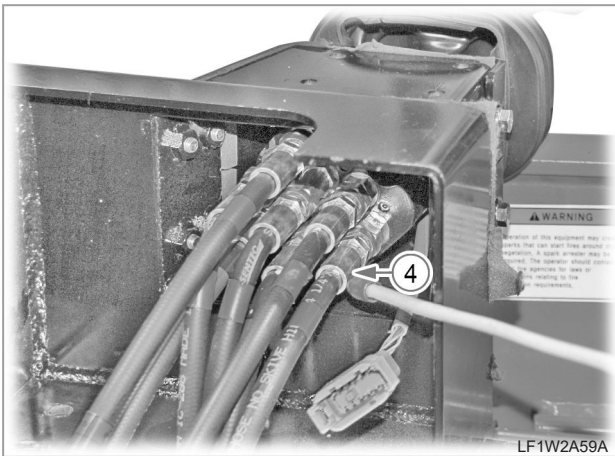
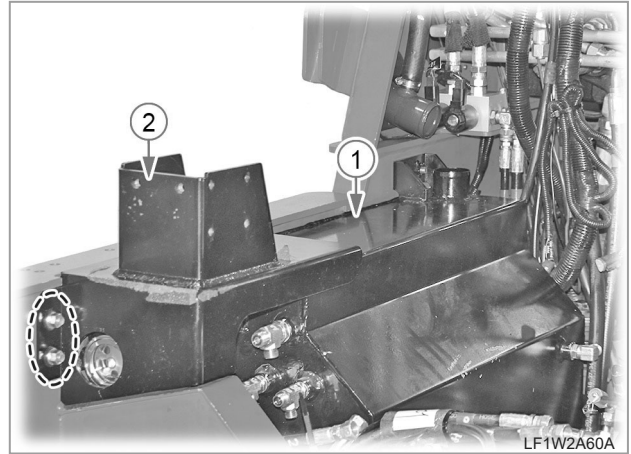
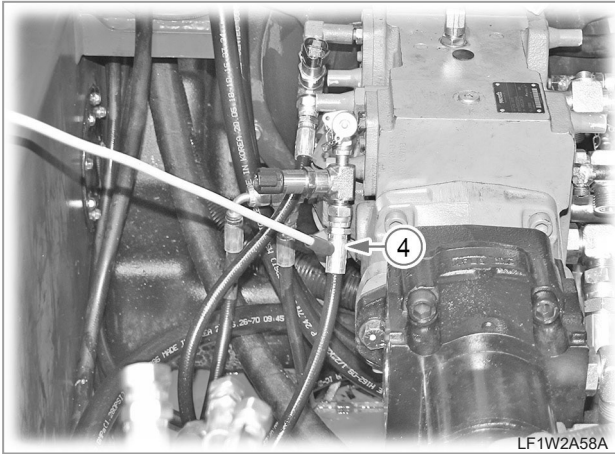

13. Connect the hydraulic hose (4) from the HST pump to the left-hand RCV (forward driving-RH).

14. Attach the oil tank (1) and RCV support (2) together.

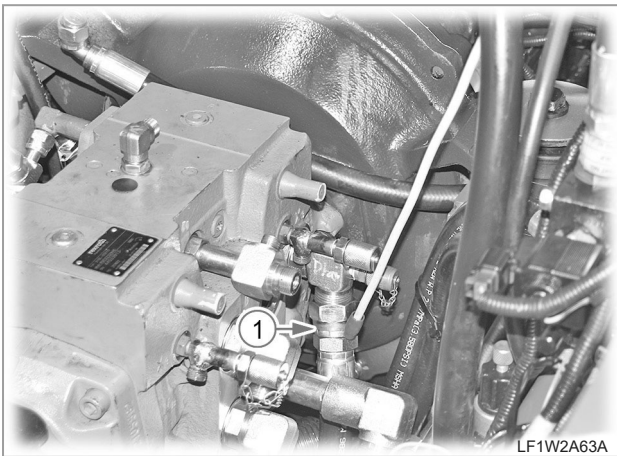
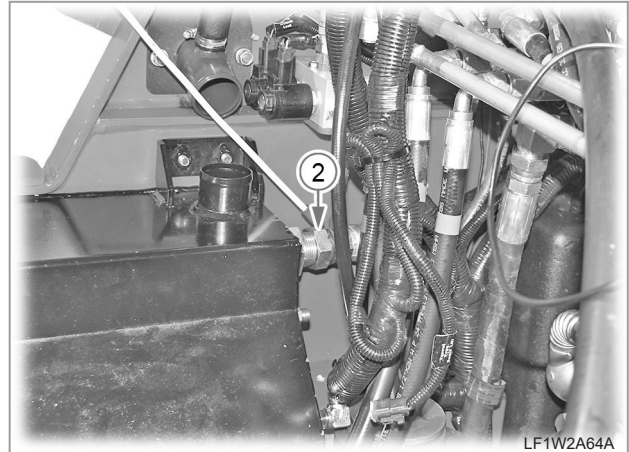
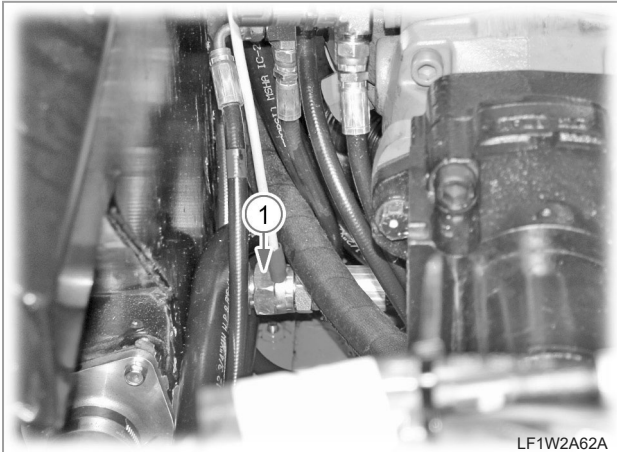

15. Connect the return hose (1) from the HST pump to the oil tank.

16. Connect the hydraulic hose (2) to the oil tank inlet and hydraulic return filter.

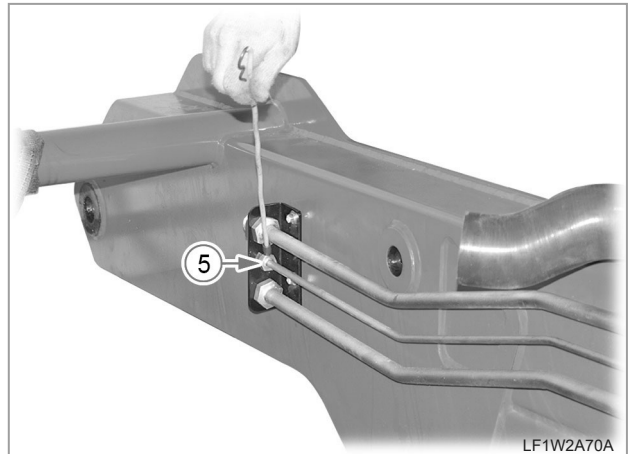
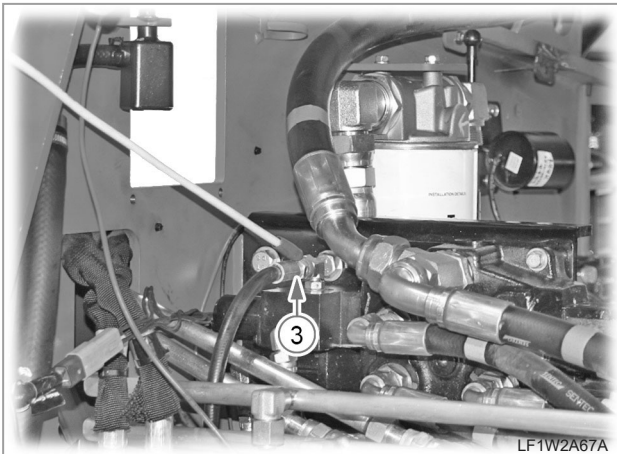
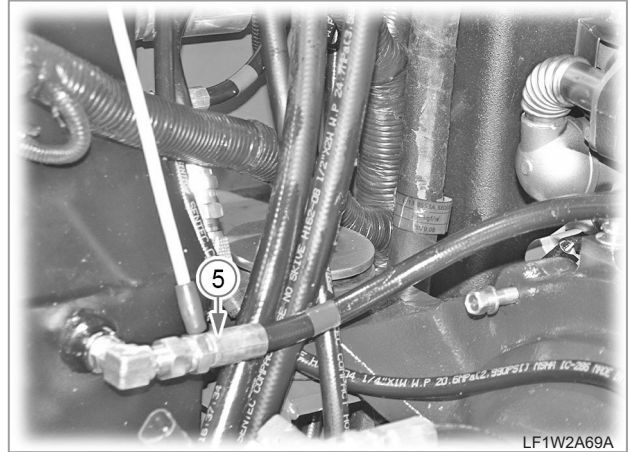
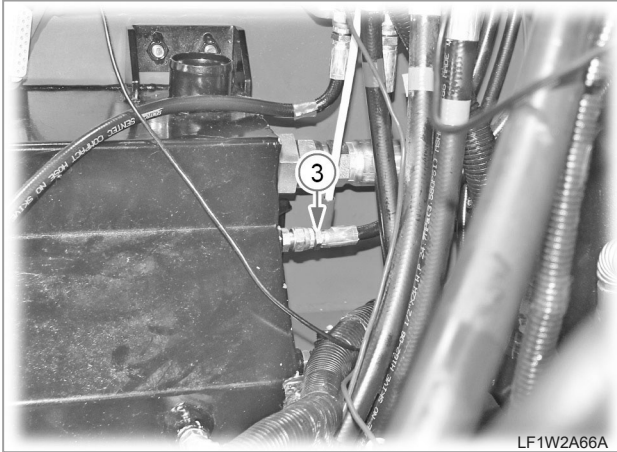

17. Install the return hose (3) between the main control valve and the oil tank.

19. Install the external hydraulic oil return hose (5) on the oil tank.

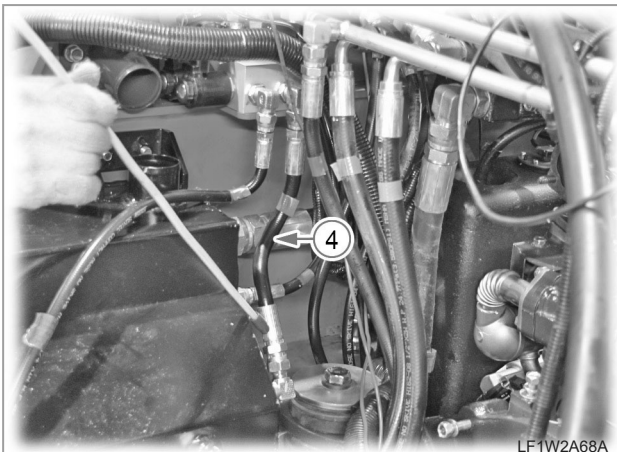

18. Connect the return hose (4) between the quick-attachment valve and the oil tank.

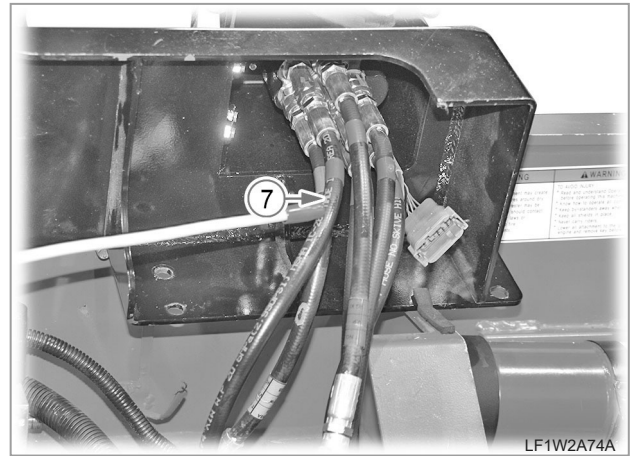
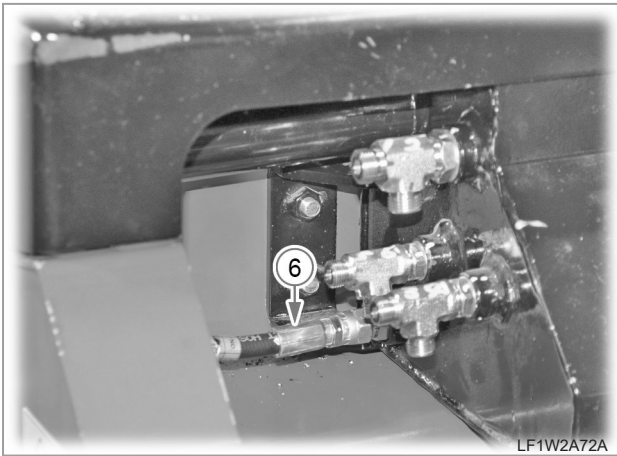
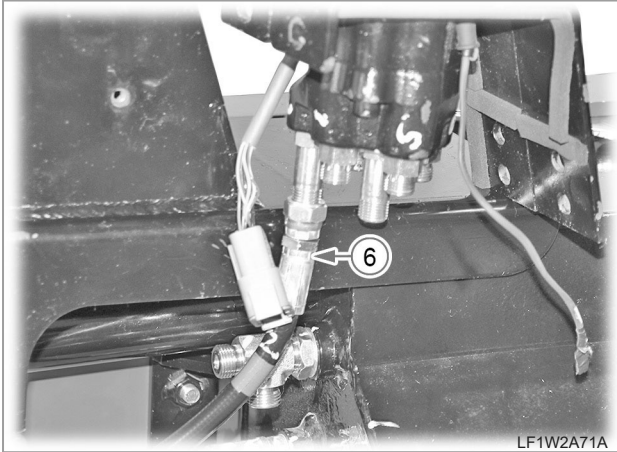

20. Install the right-hand RCV assembly return hose (6) on the oil tank.

21. Install the left-hand RCV assembly return hose (7) on the oil tank.

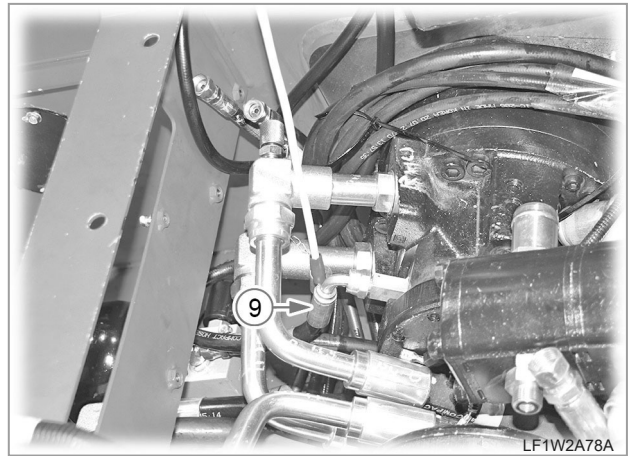
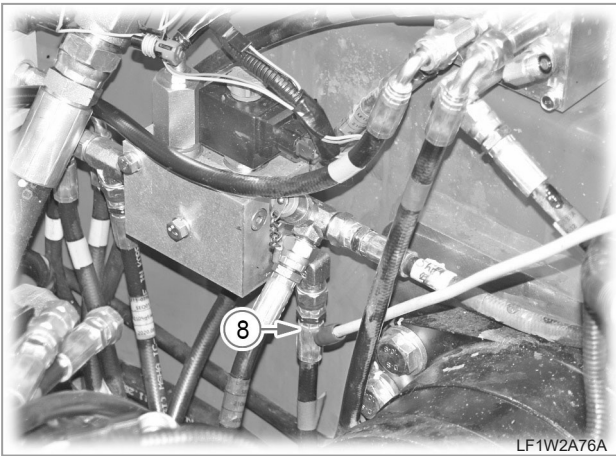
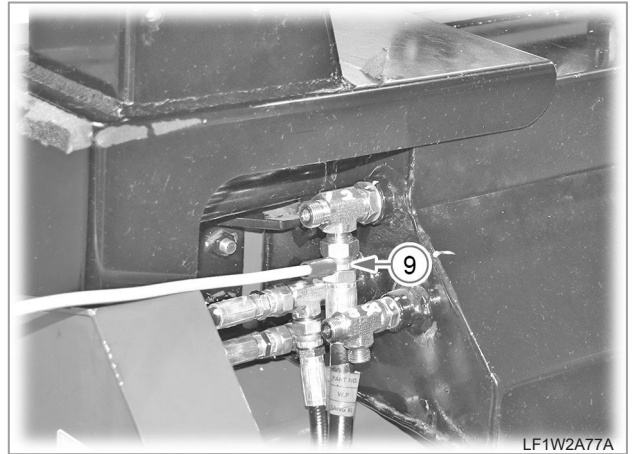
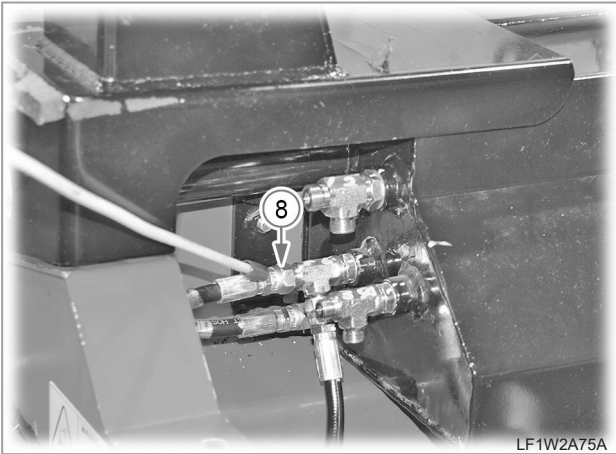

22. Install the soft shift valve return hose (8) on the oil tank.

23. Install the return hose (9) between the HST motor (RH) and the oil tank.

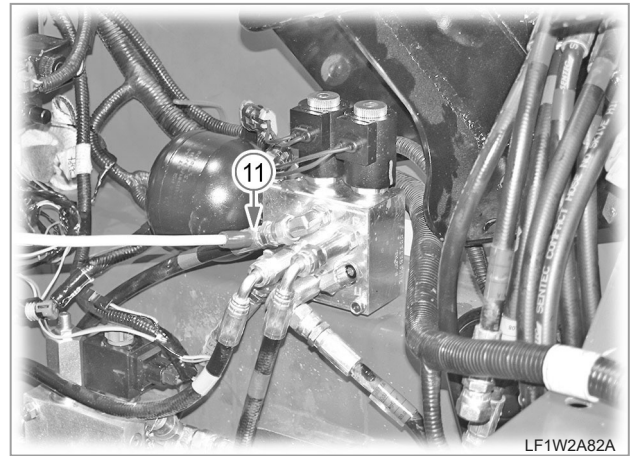
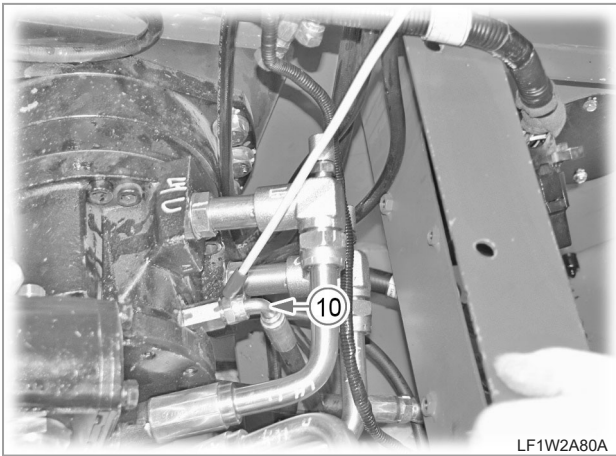
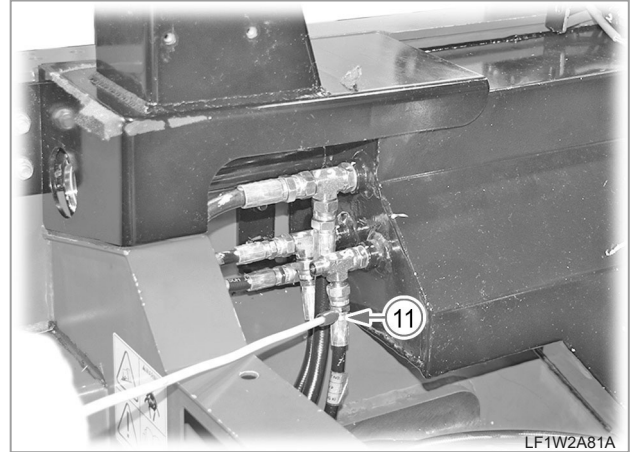
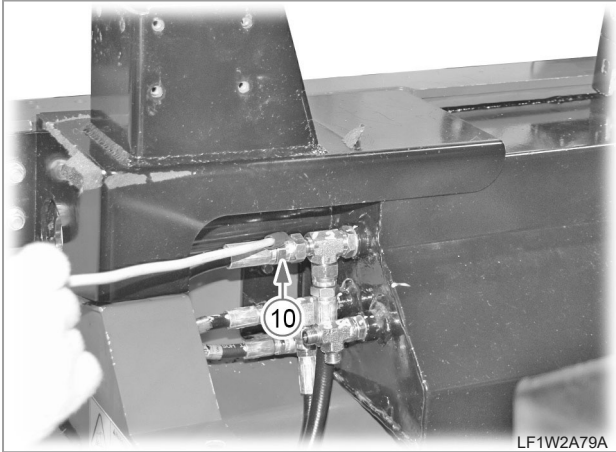

24. Install the return hose (10) between the HST motor (LH) and the oil tank.

25. Install the pilot lock valve return hose (11) on the oil tank.



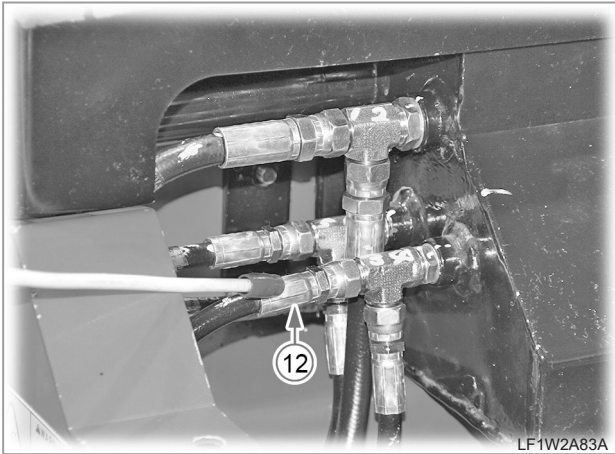

LF1W2A83A

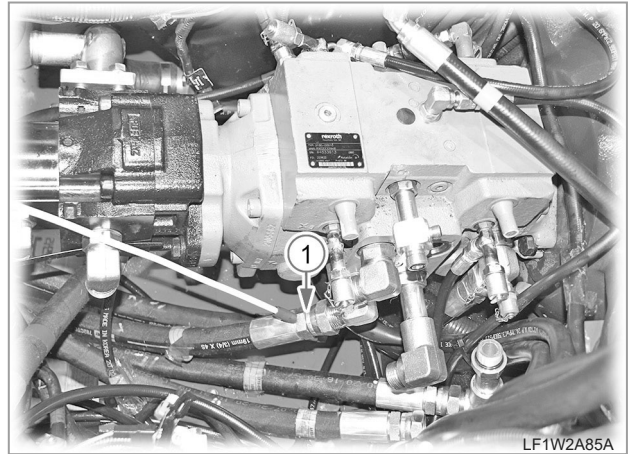

LF1W2A85A

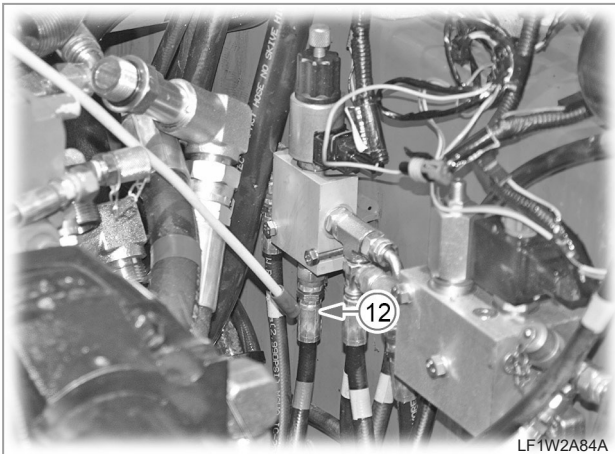

LF1W2A84A

26. Install the parking valve return hose (12) on the oil tank.

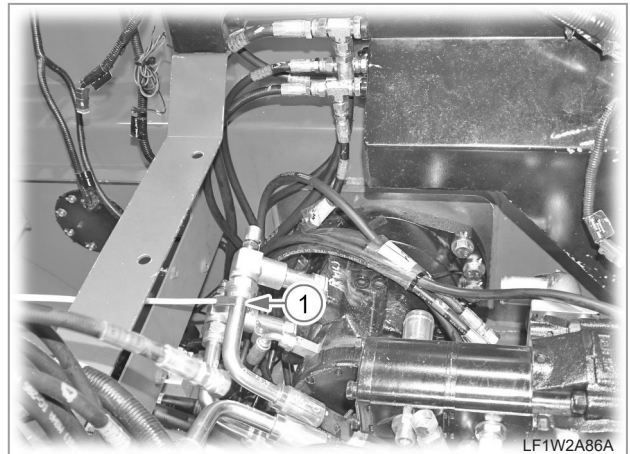

LF1W2A86A

27. Connect the hydraulic hose (1) to the HST motor (RH) (forward driving) position on the left side of the HST pump.

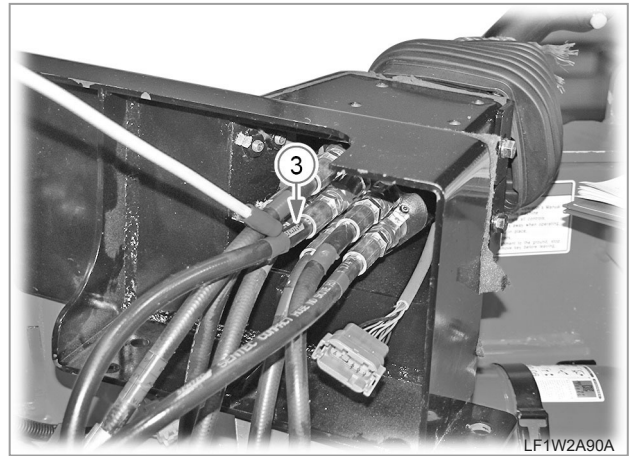
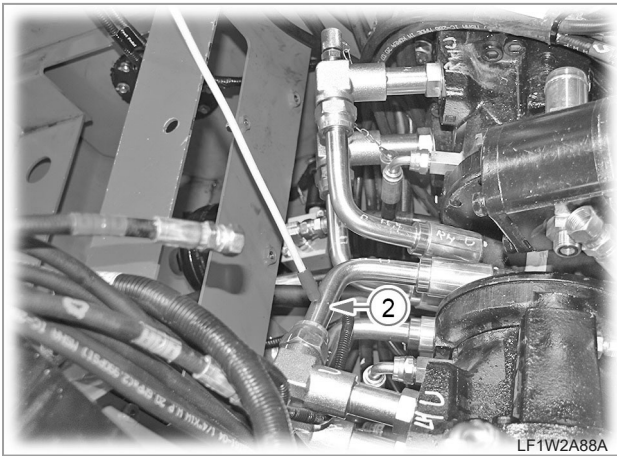
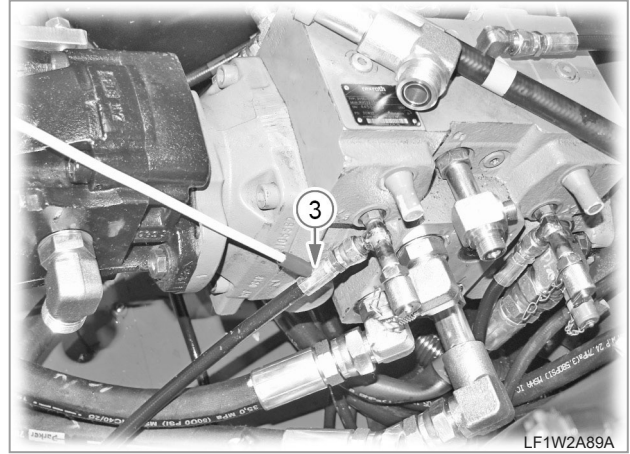

28. Connect the hydraulic hose (2) to the HST motor (LH) (forward driving) position on the HST pump.

29. Connect the hydraulic hose (3) to the RCV (LH) (reverse driving-RH) position on the HST pump.



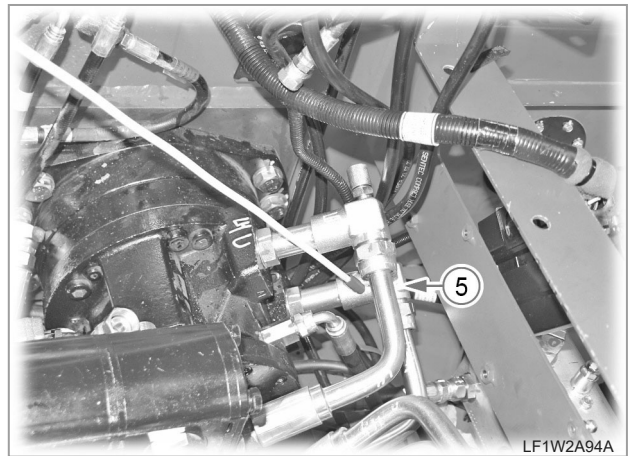
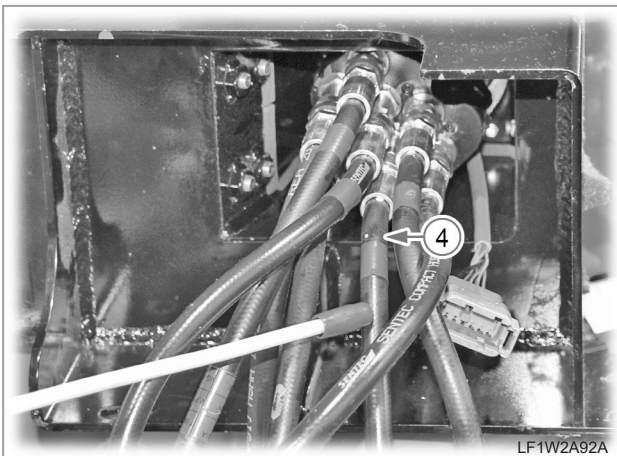
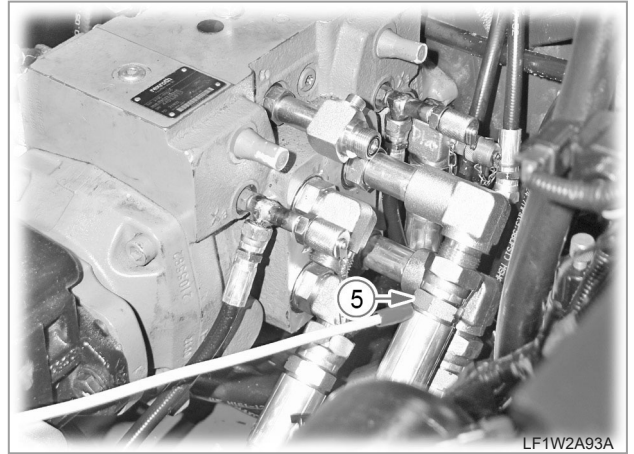
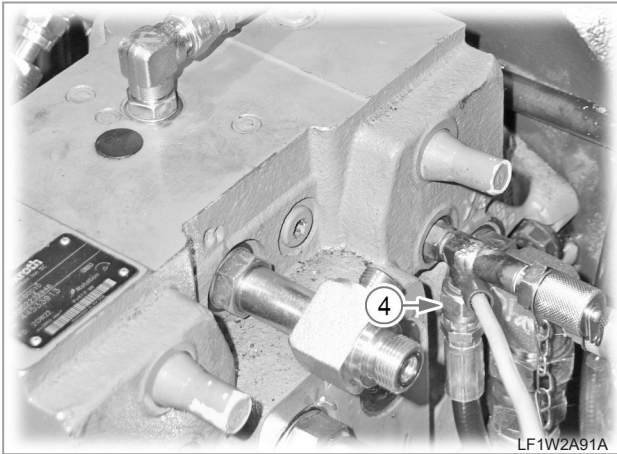

30. Connect the hydraulic hose (4) to the RCV (LH) (reverse driving-LH) position on the HST pump.

31. Connect the hydraulic hose (5) to the HST motor (LH) (reverse driving) position on the HST pump.

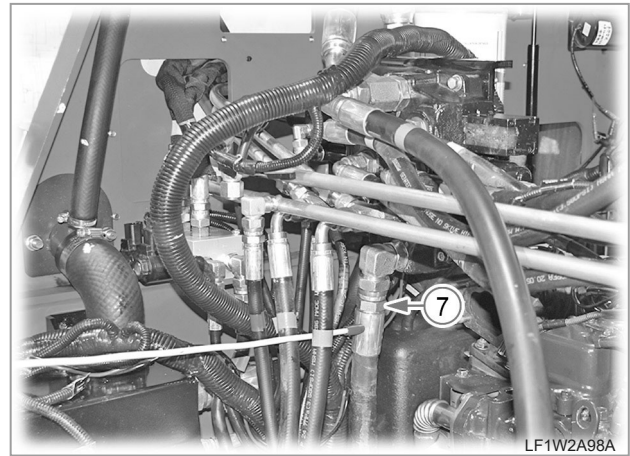
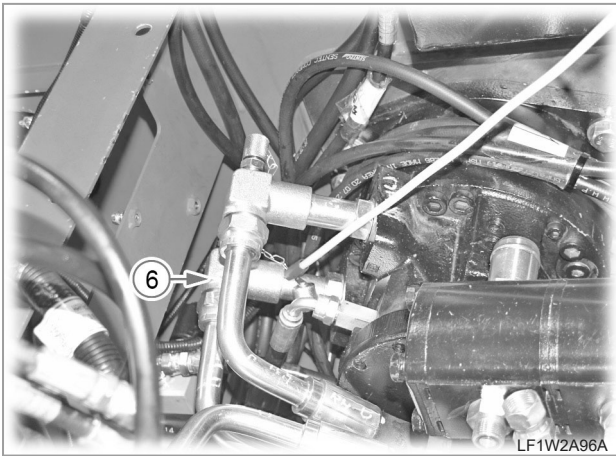
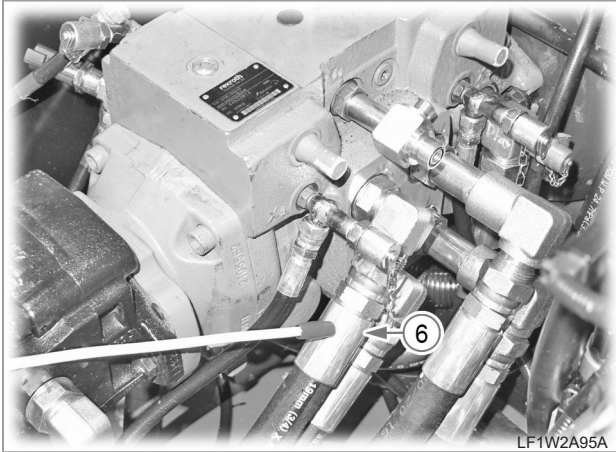

32. Connect the hydraulic hose (6) to the HST motor (RH) (forward driving) position on the HST pump.

33. Connect the hydraulic hose (7) from the main pump to the main control valve position.

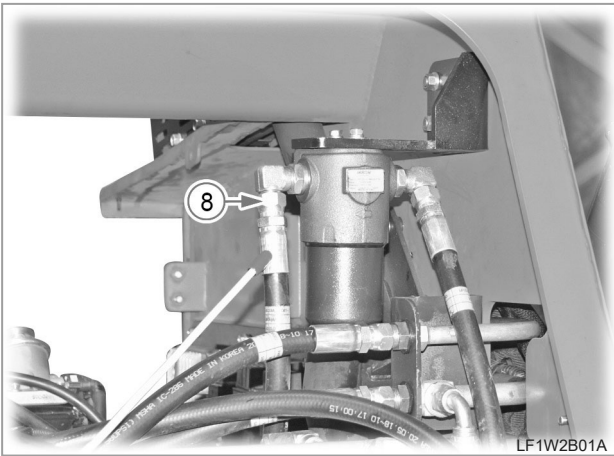
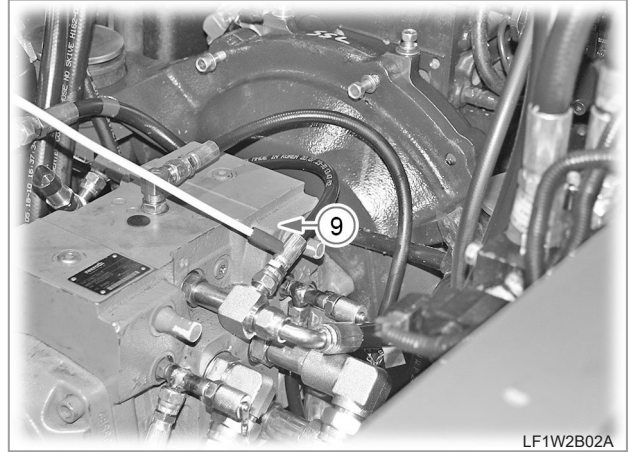
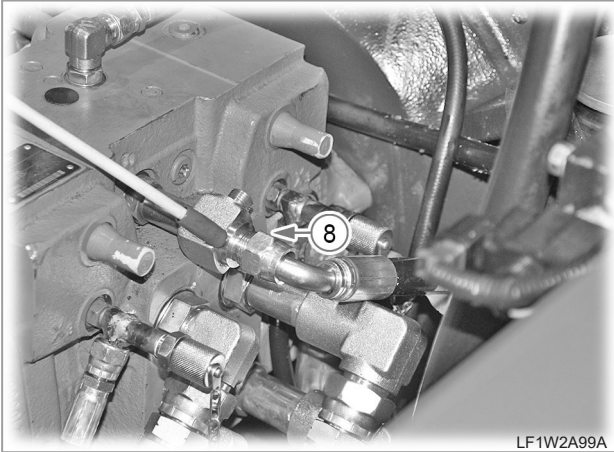

34. Connect the hydraulic hose (8) between the HST pump and HST filter.

35. Connect the hydraulic hose (9) from the HST pump to the quick-attachment valve.

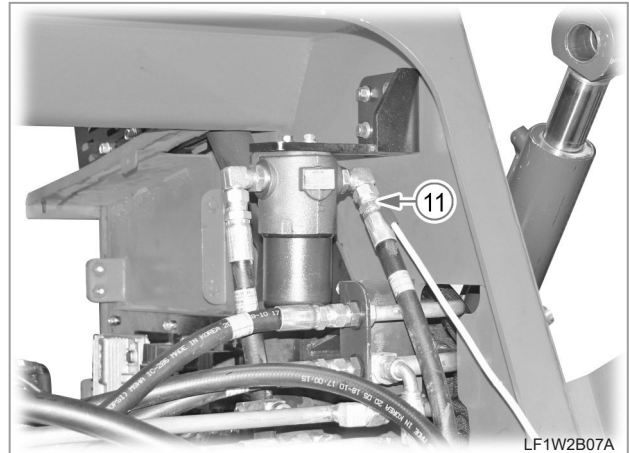
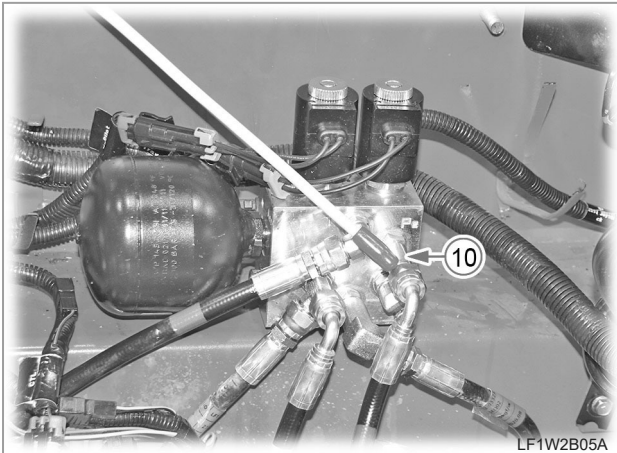
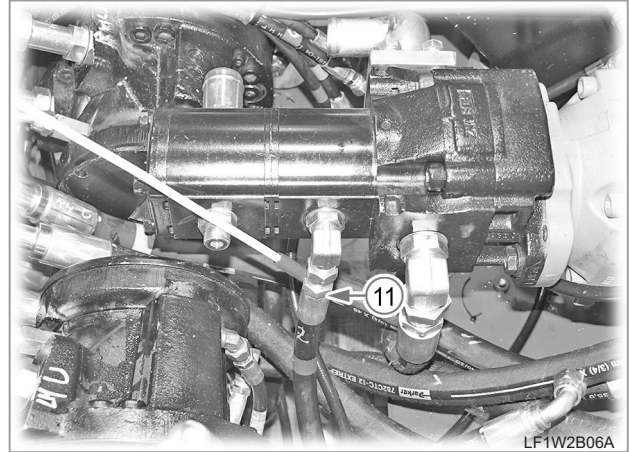
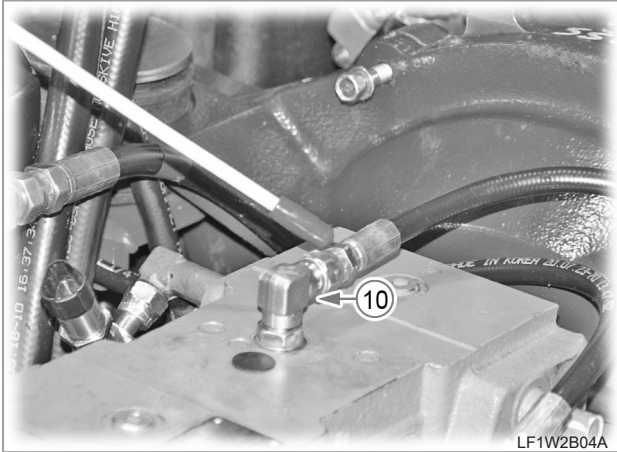

36. Connect the hydraulic hose (10) from the HST pump to the pilot lock valve.

37. Connect the hydraulic hose (11) between the charge pump and HST filter.

7.3 ENGINE COMPONENT REMOVAL

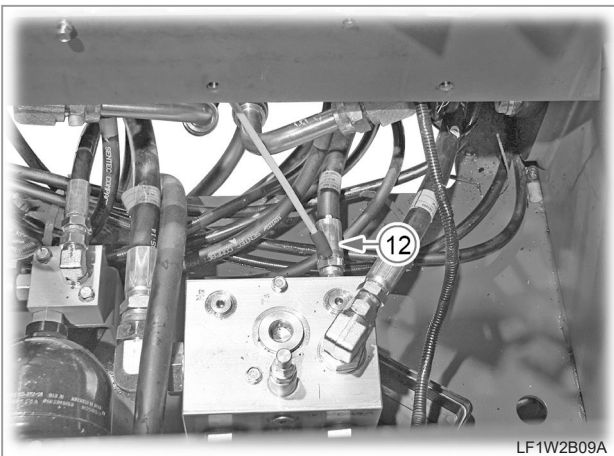
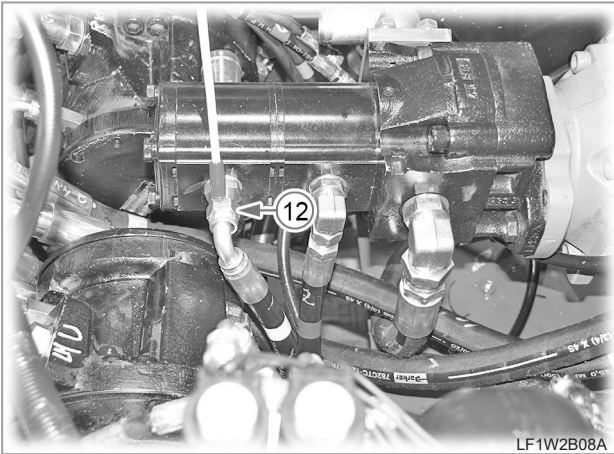

38. Connect the hydraulic hose (12) from the high-flow pump to the high-flow valve.

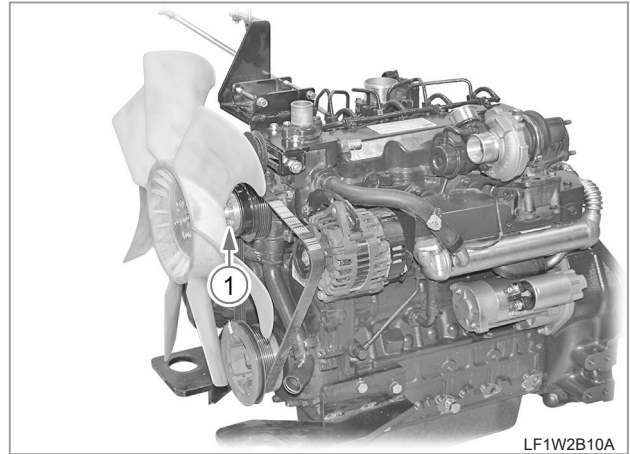

1. Unscrew the cooling fan mounting bolts (1) and then remove the cooling fan, fan collar, fan pulley, and fan belt in order.

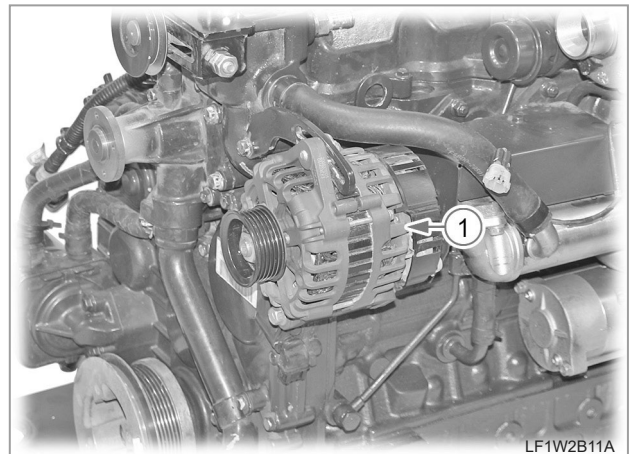

2. Remove the alternator (1).

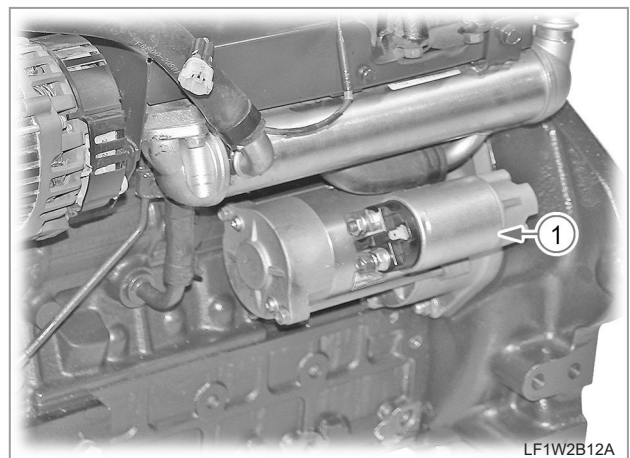

3. Remove the starter motor (1).



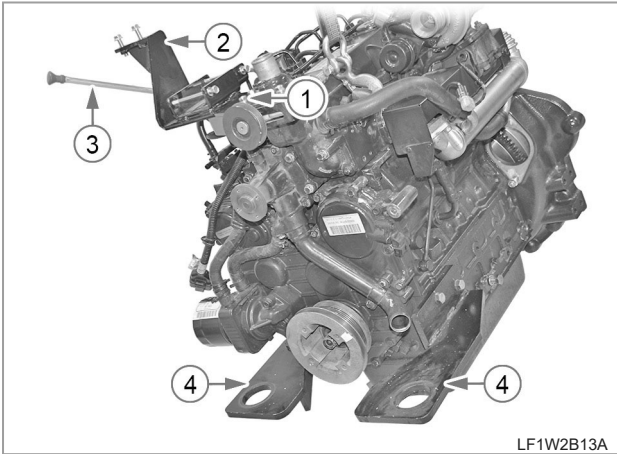

4. Unscrew the compressor support mounting bolt (1) and remove the compressor support (2), oil gauge guide (3) and engine mount bracket (4).
5. Remove sensors as necessary.

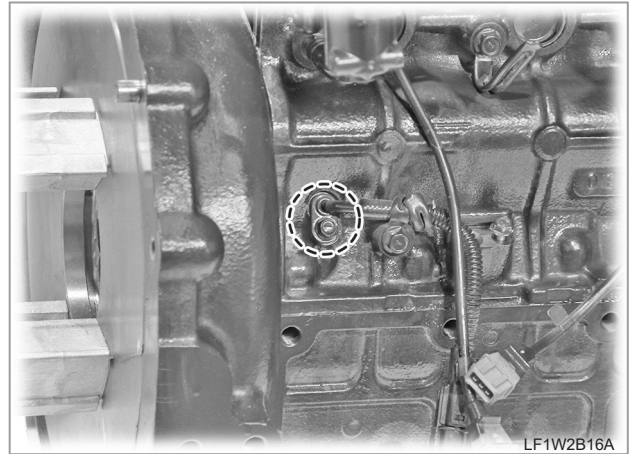

- Crankshaft wheel sensor

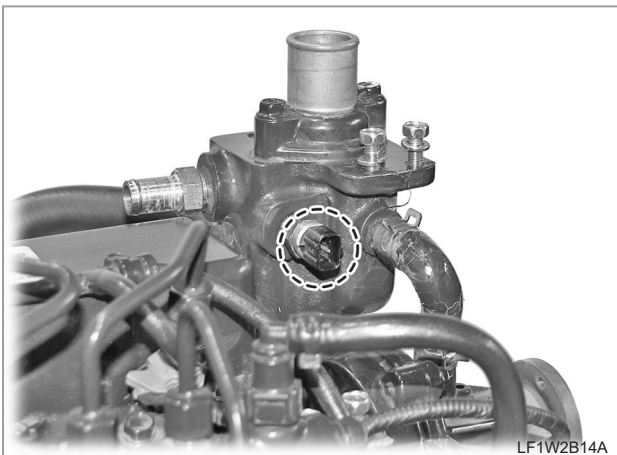

- Coolant temperature sensor

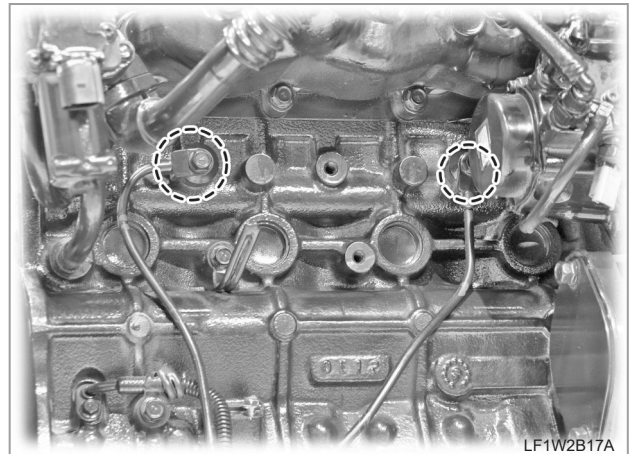

- Acceleration sensor (knock sensor)

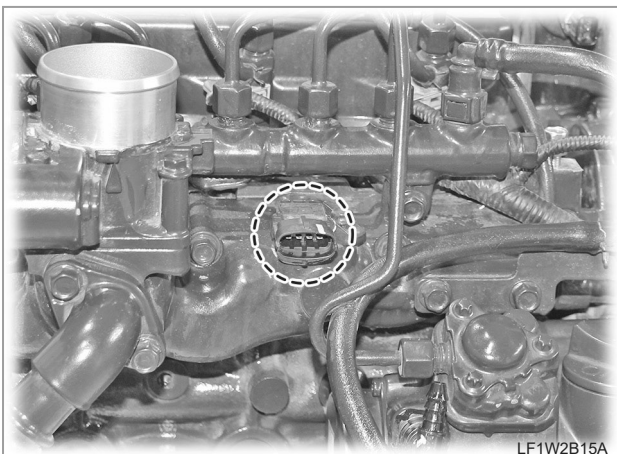

- Air temperature & pressure sensor



- Fuel (common) rail pressure sensor

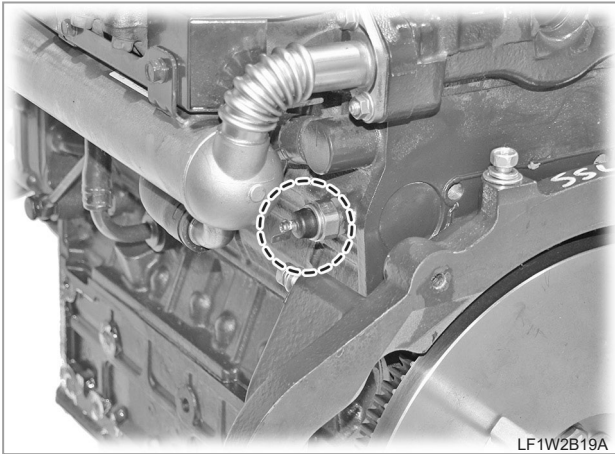

- Engine oil pressure sensor

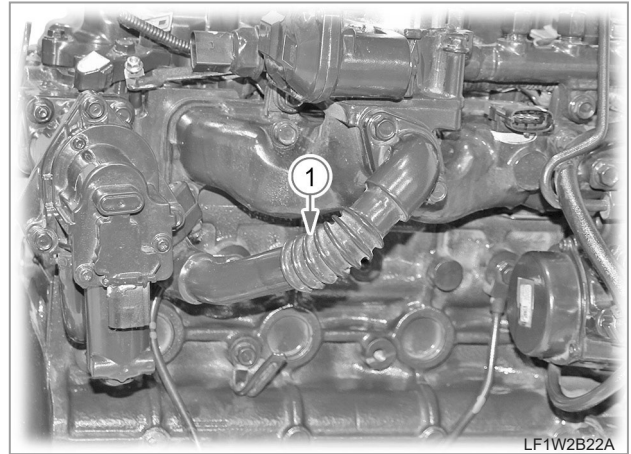

6. Disconnect the EGR pipe (1) on the intake manifold side.

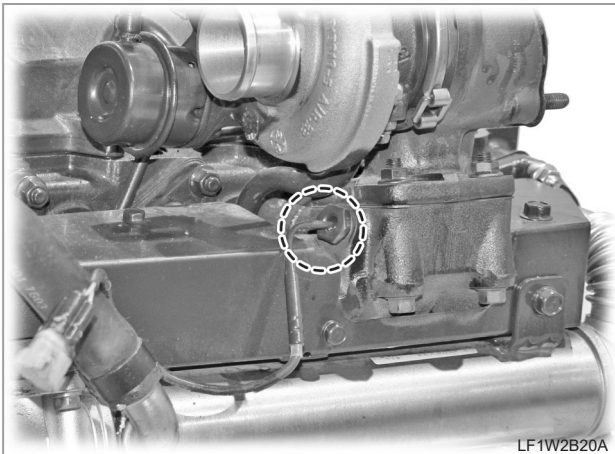

- Exhaust gas temperature sensor

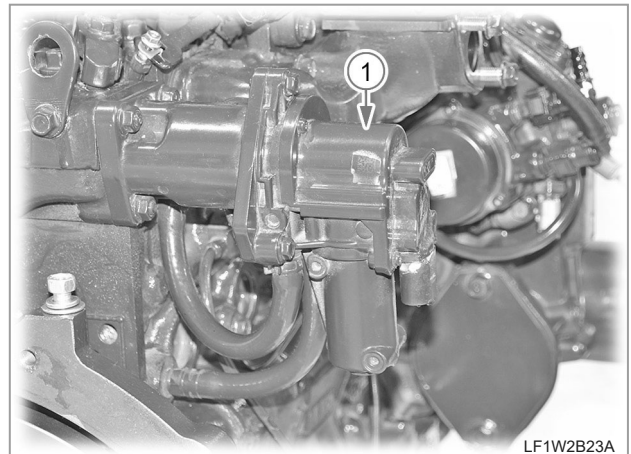

7. Remove the EGR valve assembly (1).

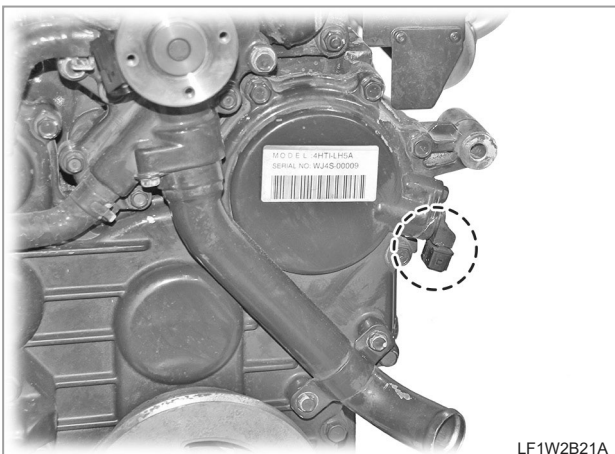

- Camshaft wheel sensor

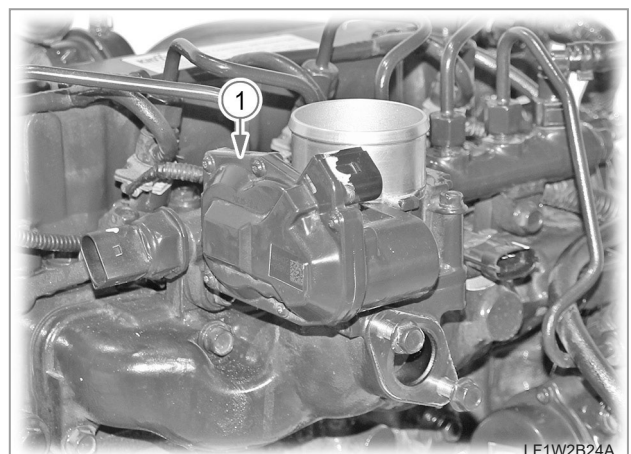

8. Remove the air control valve (1).

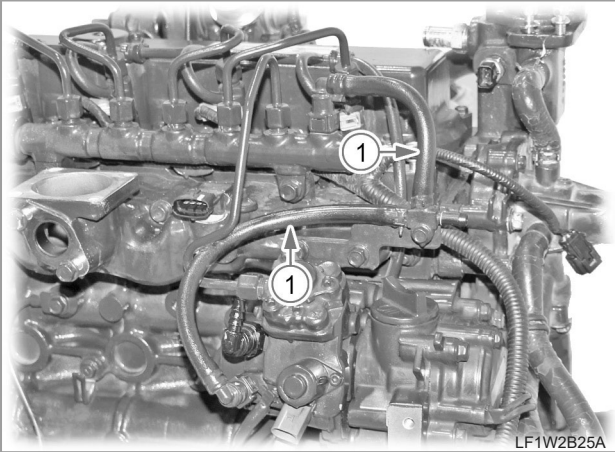

9. Disconnect fuel hose (1).

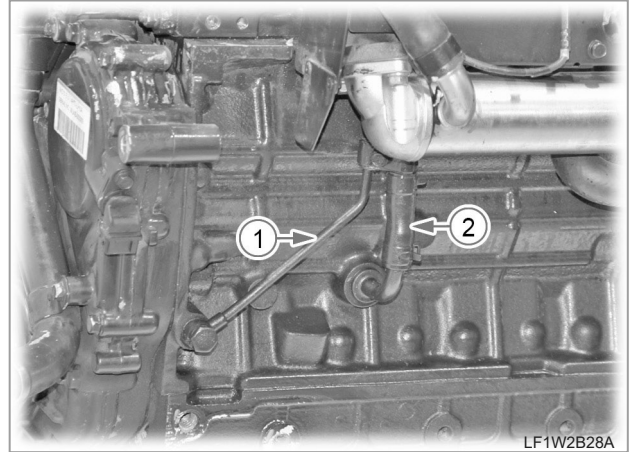

11. Disconnect the turbocharger oil supply pipe (1) and drain pipe (2).

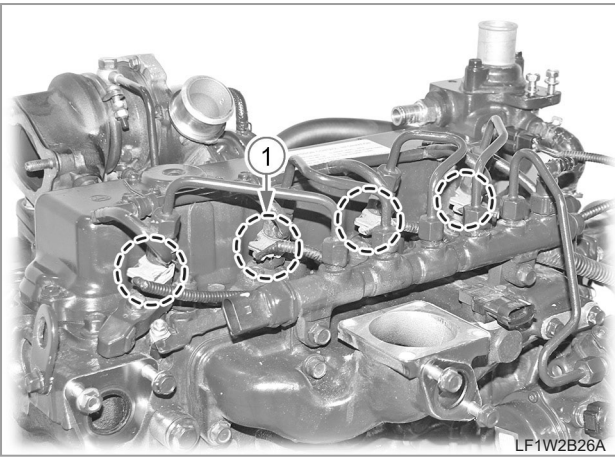

10. Disconnect injector solenoid connector (1).

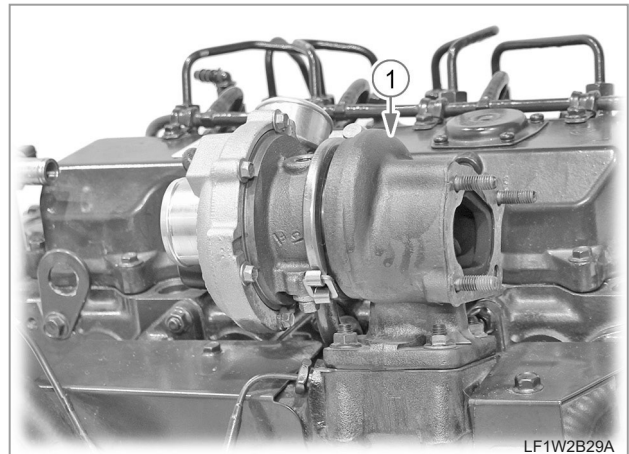

12. Remove the turbocharger assembly (1).

**CAUTION**

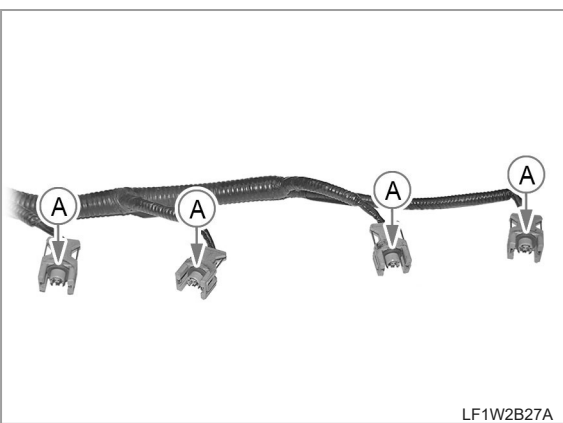

- When installing the injector solenoid connector, be careful not to miss or damage the O-ring (A).

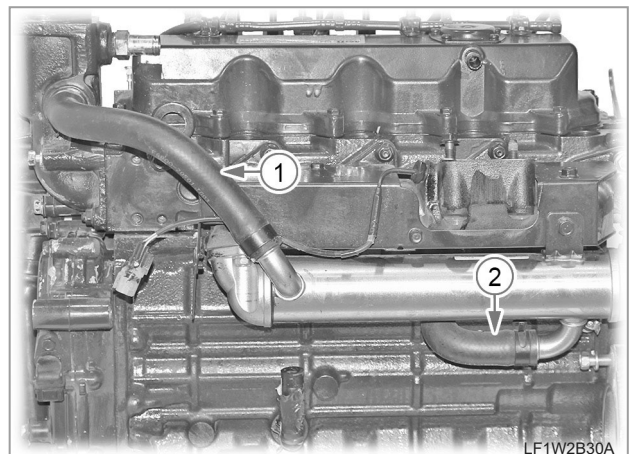

13. Disconnect the EGR cooler hoses 1 (1) and 2 (2).



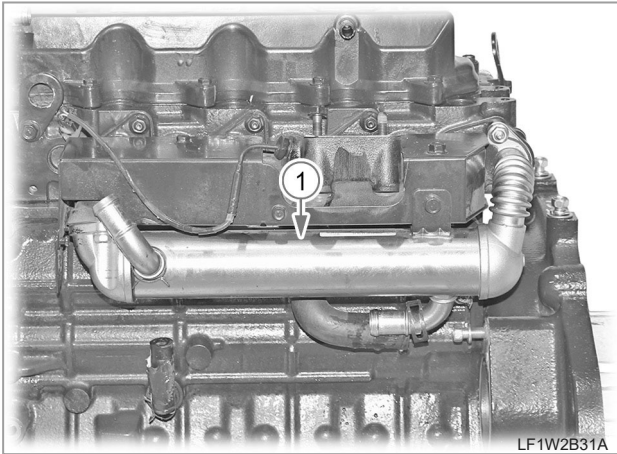

14. Remove the EGR cooler assembly (1).

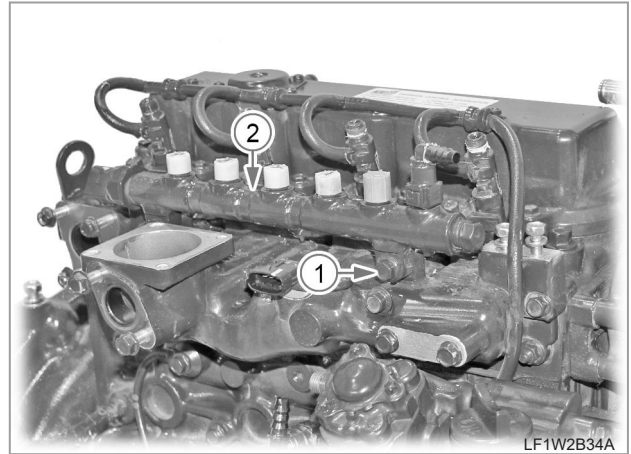

17. Unscrew the fuel rail mounting bolts (1) to remove the fuel rail assembly (2).

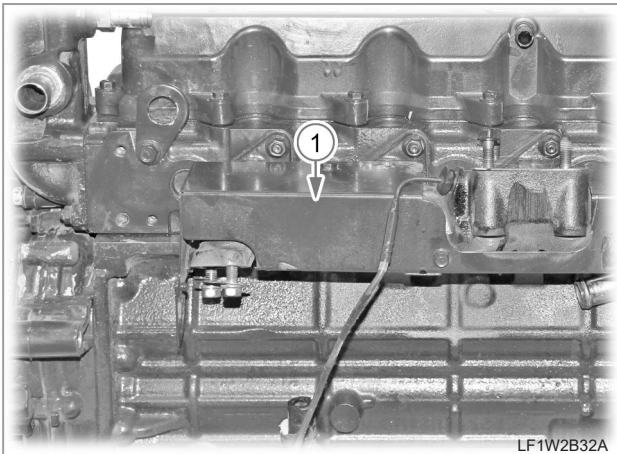

15. Remove the shield plate (1) on the exhaust manifold side.

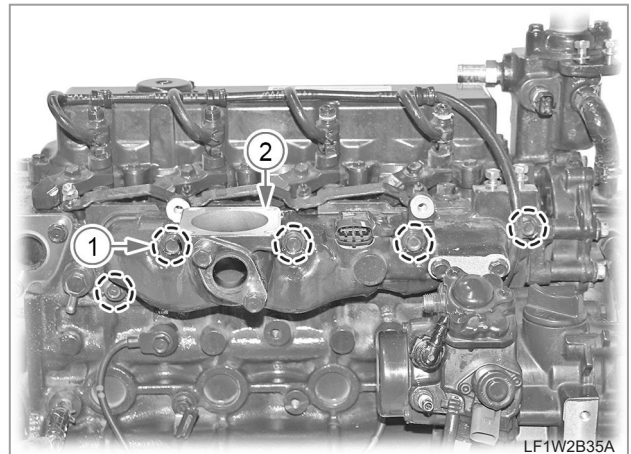

18. Unscrew the intake manifold mounting bolts (1) to remove the intake manifold (2).

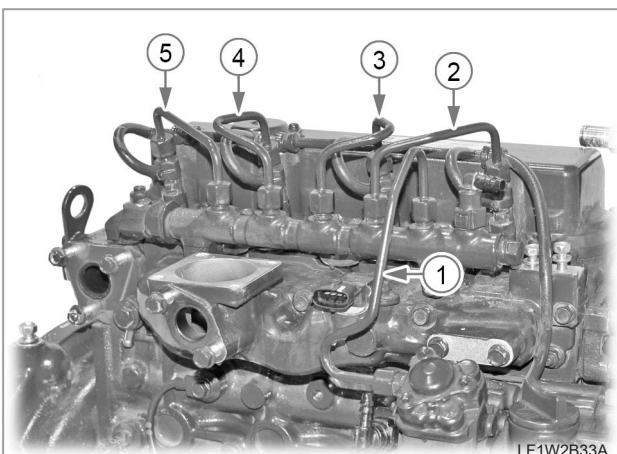

16. Disconnect the fuel rail pipe (1) and injection pipes (2, 3, 4 & 5).

**High-pressure pipe nut**

tightening torque .....  $27.4 \pm 31.4$  Nm  
 $2.8 \pm 3.2$  kgf-m  
 $20.2 \pm 23.0$  lb-ft

**Mounting bolt**

tightening torque .....  $23.5 \pm 27.4$  Nm  
 $2.4 \pm 2.8$  kgf-m  
 $17.3 \pm 20.2$  lb-ft

**CAUTION**

- When it is necessary to replace the fuel rail pressure sensor, the whole fuel rail assembly should be replaced.

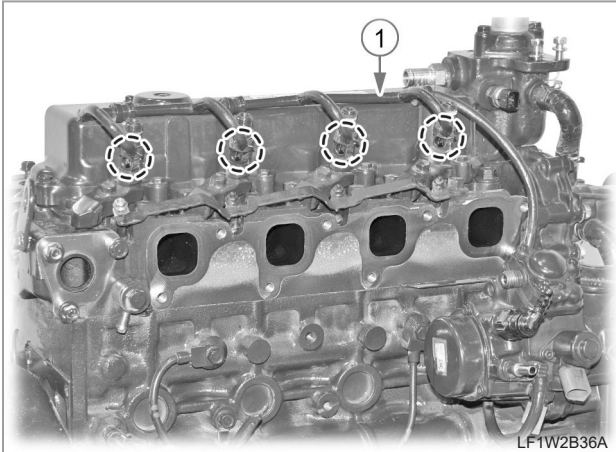

19. Remove the injector return tube assembly (1).

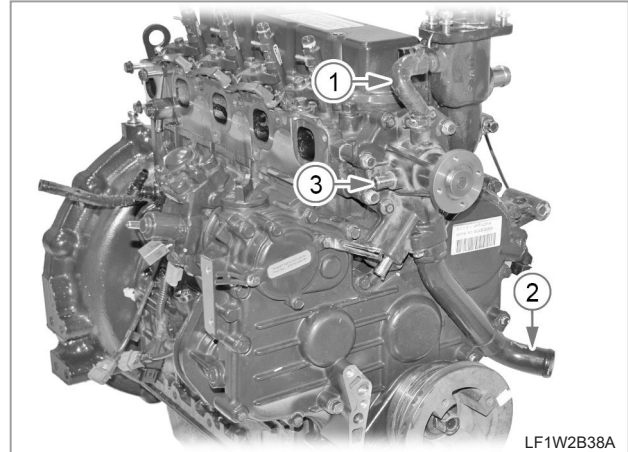

21. Disconnect the coolant return hose (1) and remove the water pump pipe (2) and water pump assembly (3).

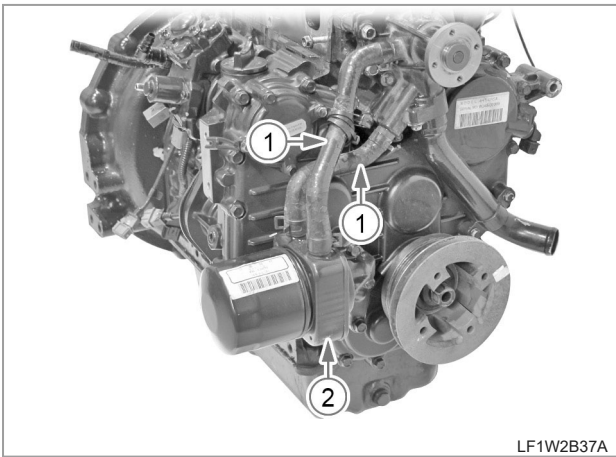

20. Disconnect the oil cooler connecting hose (1) and remove the oil cooler (2) with the oil filter.

**⚠ CAUTION**

- If foreign materials are introduced into the fuel system in the direct injection type engine, major defect can occur between the high-pressure fuel pump and injector. When replacing or servicing any fuel connecting pipe or fuel system part, seal it to prevent introduction of any foreign material.
- Replace the fuel pipes between the high-pressure fuel pump, fuel rail and injectors with new ones during reassembly.

7.4 ENGINE DISASSEMBLY

7.4.1 HEAD COVER

**REMOVAL**

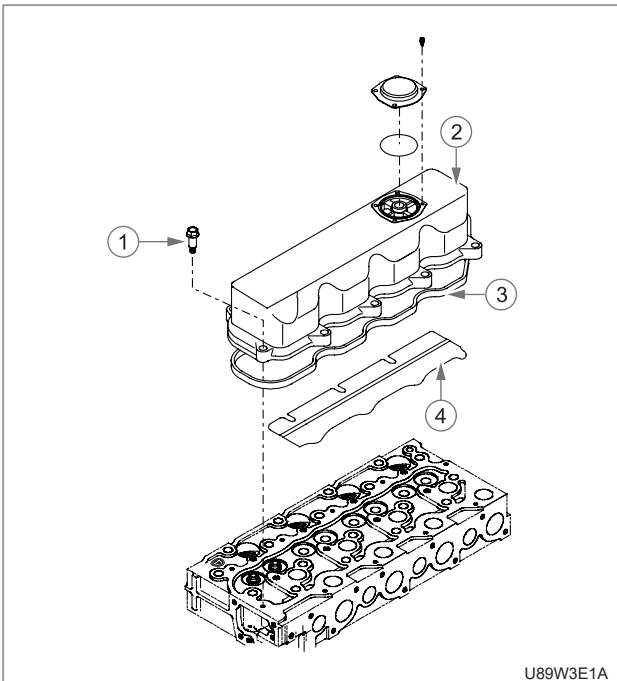
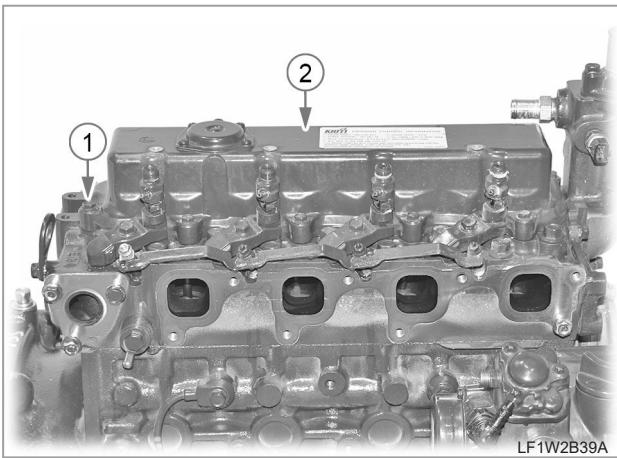

1. Remove the cylinder head cover bolts (1).
2. Remove the head cover (2) and gasket (3).
3. Remove the oil baffle plate (4) if necessary.

**INSTALLATION**

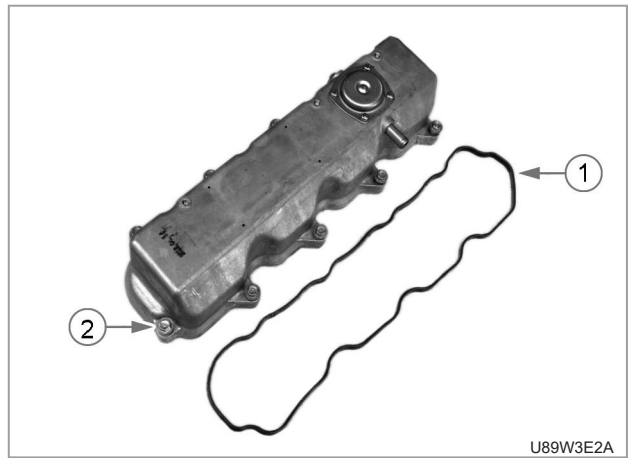

1. Make sure that the head cover gasket is well seated on the groove of the cylinder head cover.
2. When installing the head cover, keep the specified tightening torque and tighten the bolts (2) gradually into 3 ~ 4 steps.
3. Ensure that the cylinder head cover gasket (1) is not defective.

**Cylinder head cover bolt (M8)**

tightening torque.....	8.8 ~ 11.8 Nm
	0.9 ~ 1.2 kgf-m
	6.5 ~ 8.7 lb-ft

7.4.2 GLOW PLUG AND INJECTOR

SAFETY FIRST

ENGINE

DRIVING & CHASSIS

HYDRAULIC SYSTEM

ELECTRIC SYSTEM

CABIN

INDEX

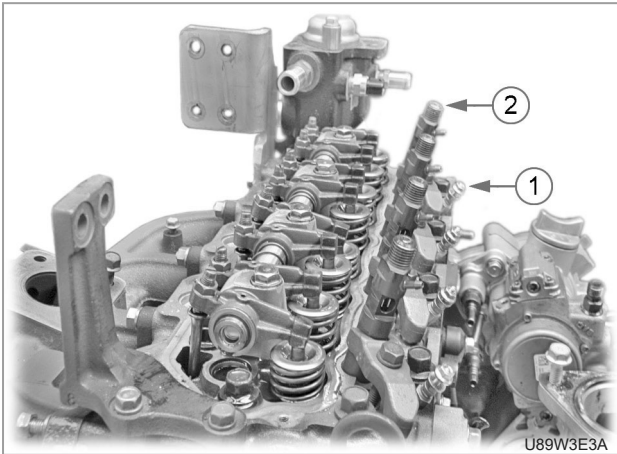

(1) Glow plug

(2) Injector

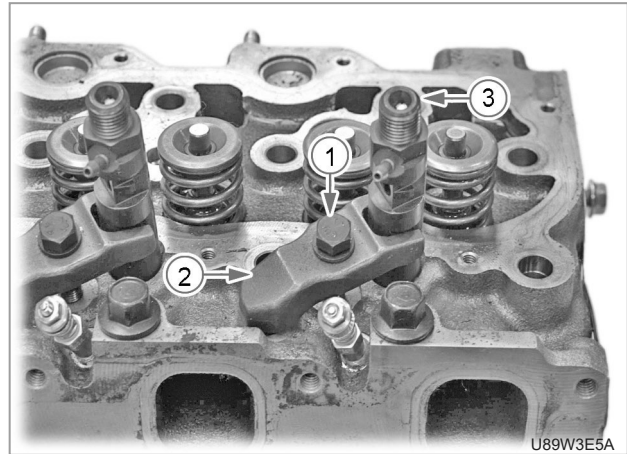

1. Screw out the glow plug (1) from the intake side of the cylinder head.

**Glow plug**  
 tightening torque .....  $19.6 \pm 24.5 \text{ Nm}$   
 $2 \pm 2.5 \text{ kgf-m}$   
 $14.4 \pm 18.0 \text{ lb-ft}$

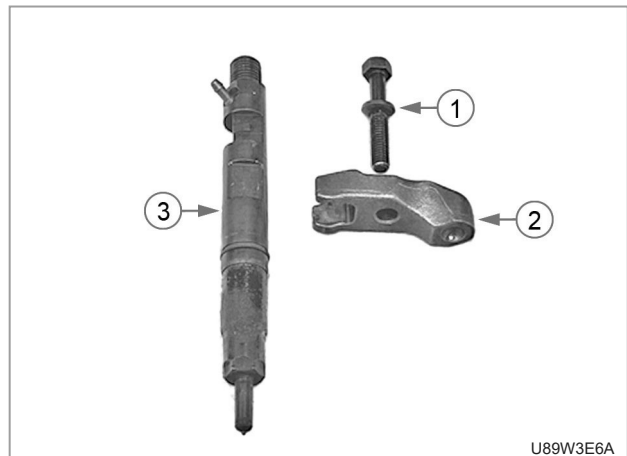

2. Unscrew the clamp mounting bolt (1) to remove the clamp (2) and injector (3).

**Mounting bolt**  
 tightening torque .....  $27.4 \pm 31.4 \text{ Nm}$   
 $2.8 \pm 3.2 \text{ kgf-m}$   
 $20.2 \pm 23.0 \text{ lb-ft}$

**CAUTION**

- When the injector is removed, it should be installed to the original position afterwards. When replacing the injector with a new one, connect the scan tool to the ECU and enter the injector code to the scan tool. (Refer to the instructions for injector code management in the Section 3.4.7.)

7.4.3 ROCKER ARM ASSEMBLY

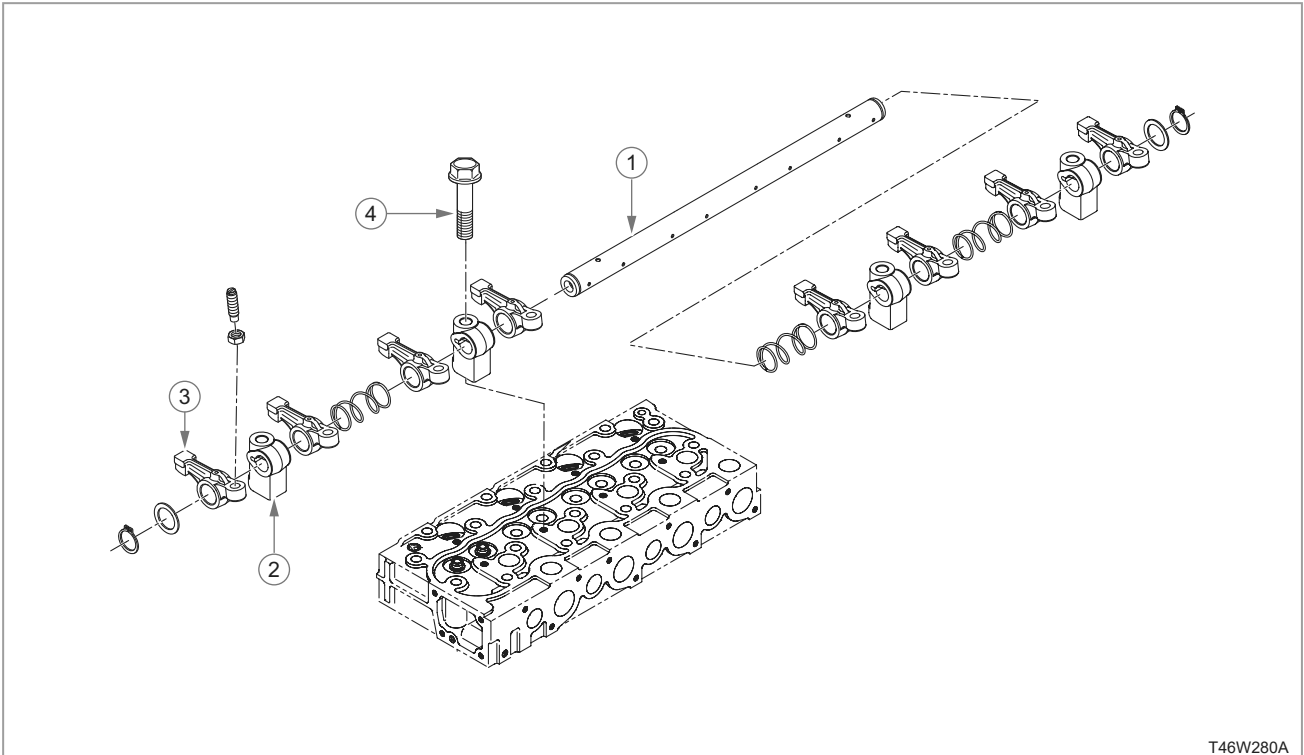

T46W280A

- (1) Rocker arm shaft
- (2) Rocker arm

- (3) Rocker arm support
- (4) Rocker arm support bolt

**REMOVAL**

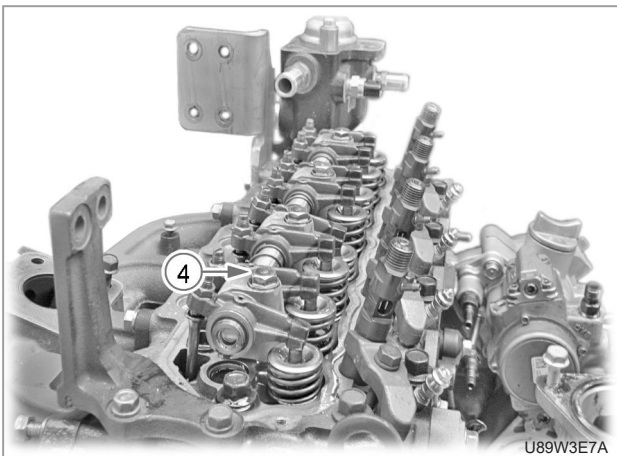

U89W3E7A

1. Remove the rocker arm mounting bolts (4) by loosening them in several steps.
2. Remove the rocker arm assembly and the push rod.

**INSTALLATION**

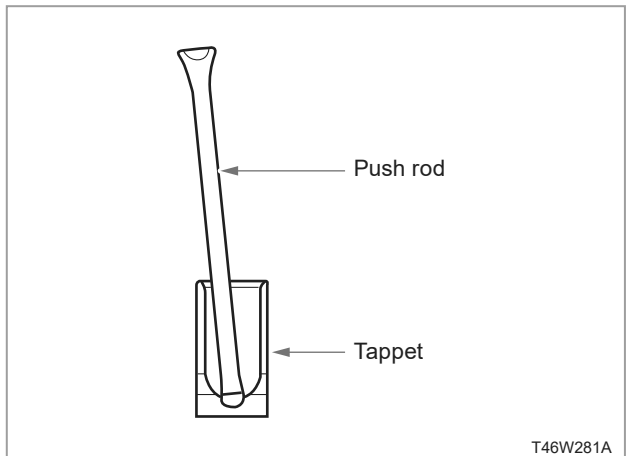

T46W281A

1. Make sure that the push rod is seated on the concave area of the tappet.

**ROCKER ARM ASSEMBLY CHECK**

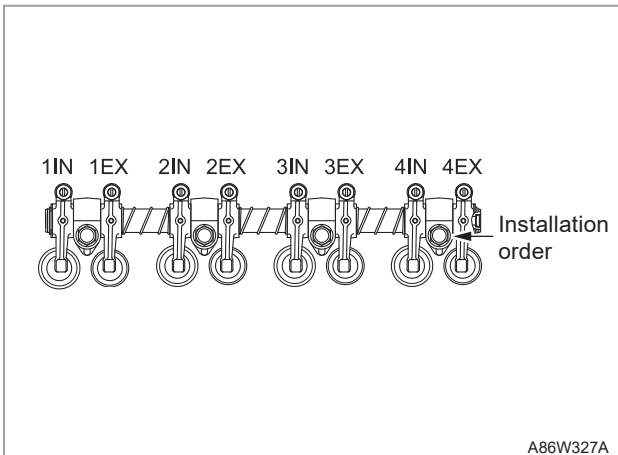

A86W327A

2. Tighten the rocker arm support bolts to the specified torque in several steps with the specified sequence as shown in the figure.
3. Adjust the valve clearance after assembling the rocker arm assembly.

**! IMPOARTANT**

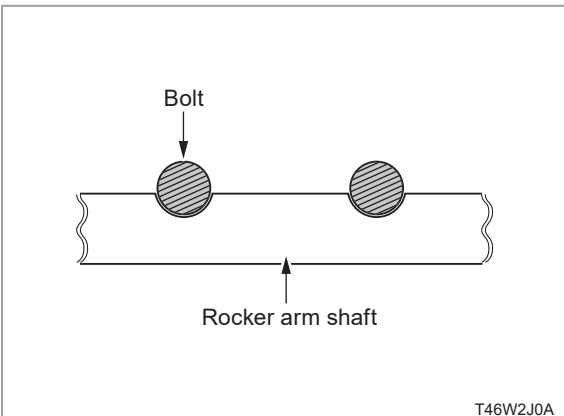

T46W2J0A

- To tighten the rocker arm support bolt, the groove on the rocker arm shaft should face the bolt.

**Rocker arm mounting bolt**

(M10)..... 60.8 ~ 73.5 Nm  
 6.2 ~ 7.2 kgf-m  
 44.8 ~ 54.2 lb-ft

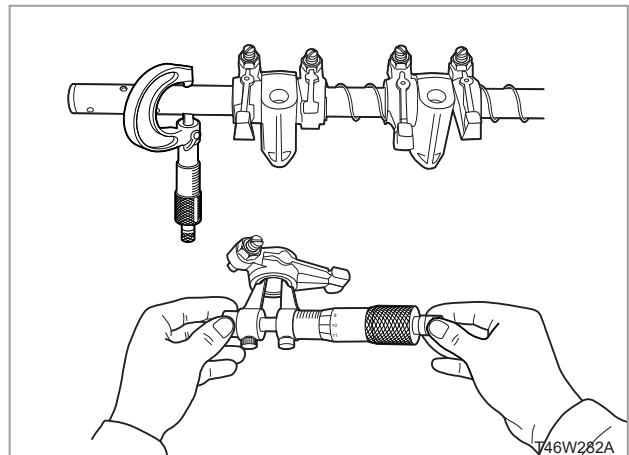

T46W282A

1. Measure the rocker arm I.D. with an inside micrometer.
2. Measure the rocker arm shaft O.D. with an outside micrometer.
3. If the clearance exceeds the allowable limit, replace the rocker arm.
4. If the clearance still exceeds the allowable limit after replacing the rocker arm, replace the rocker arm shaft.

Clearance	Specified size	0.020 ~ 0.070 mm (0.00079 ~ 0.00276 in.)
	Allowable limit	0.15 mm (0.0059 in.)
Rocker arm shaft O.D.	Specified size	18.955 ~ 18.980 mm (0.74626 ~ 0.74724 in.)
Rocker arm I.D.	Specified size	19.000 ~ 19.025 mm (0.74803 ~ 0.74902 in.)

7.4.4 CYLINDER HEAD

**CYLINDER HEAD REMOVAL**

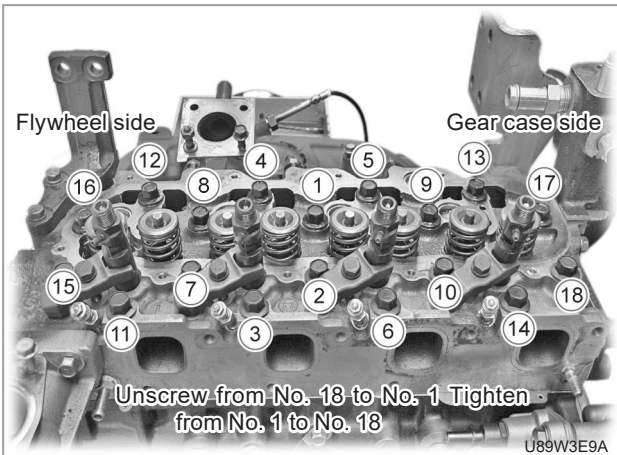
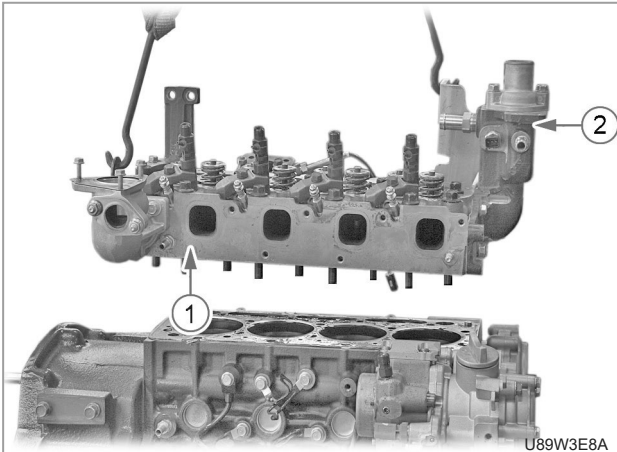

1. Loosen the head bolts in the reverse sequence as shown in the figure. (Follow the sequence in the figure when tightening them.)
2. Lift the head (1) slightly with a hoist by using the hook.
3. Remove the coolant flange (2) if necessary.
4. Remove the tappets from the cylinder block.

**CAUTION**

- Mark the cylinder number to the tappets to prevent them from interchanging.

**! IMPOARTANT**

**CYLINDER HEAD BOLT TIGHTENING METHOD**

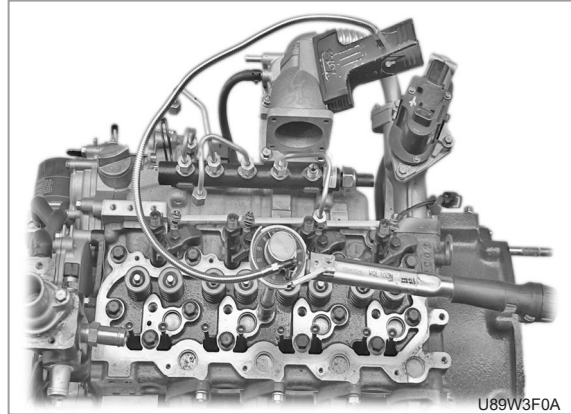

1. Add a little engine oil to the thread and bottom face of bolt head.
2. Tighten the head bolt to 4 kgf-m in accordance with head bolt tightening order.
3. Tighten every bolts 90° with angle torque wrench in accordance with tightening order.
4. Tighten bolts 70° more in accordance with tightening order.
5. Do not re-use old head bolts.

**REMARKS**

- A, B seires engine: 4 kgf-m + 90° + 80°
- F, H seires engine : 4 kgf-m + 90° + 70°

**CYLINDER HEAD INSTALLATION**

1. Apply the liquid gasket (Three bond 1215 or equivalent) on both sides of coolant flange gasket.
2. Always replace the head gasket with a new one. Pay particular attention to its direction and orientation.
3. Remove any gasket residue out of mating surfaces of the cylinder head and cylinder block before installing the new cylinder head gasket. Be careful not to get the residue enter into the block or the head. (Use a vacuum cleaner to clean the residue.)
4. Before installing the tappets, apply engine oil around them.

**! IMPOARTANT**

- Check the torque after 30 minutes operation of the assembled engine, and adjust valve clearance.
- Tightening torgue and angle.

1st Round	2nd Round	3rd Round
4 kgf-m	90°	70°

**CYLINDER HEAD SURFACE FLATNESS CHECK**

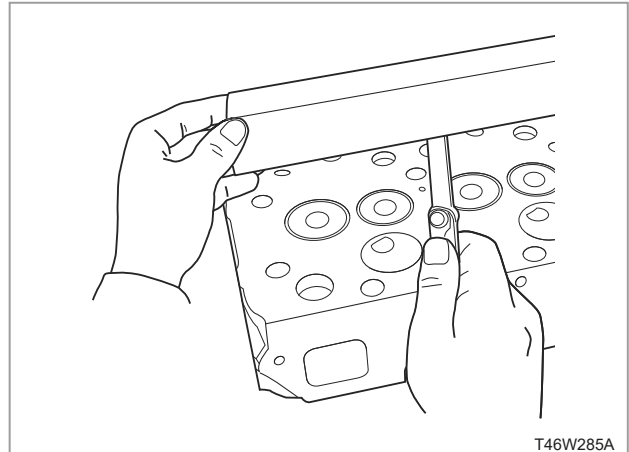

1. Thoroughly clean the cylinder head surface.
2. Place a straight edge on the cylinder head and measure the clearance with a feeler gage as shown in the figure.
3. If the measured value exceeds the allowable limit, replace the cylinder head.

**! IMPOARTANT**

- Do not place the straight edge on the combustion chamber.

Allowable limit ..... 0.05 mm  
0.0019 in.



7.4.5 INTAKE AND EXHAUST VALVES

**VALVE REMOVAL**

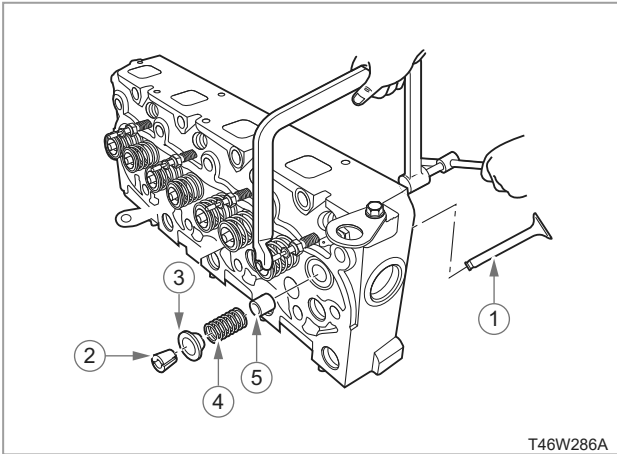

- (1) Valve
- (2) Collet
- (3) Retainer
- (4) Valve spring
- (5) Valve stem seal

1. Compress the valve spring with the replacer and remove the collet (2).
2. Remove the retainer (3), valve spring (4), valve stem seal (5) and the valve (1).

**! IMPOARTANT**

- Be careful not to interchange the valves and related components.
- Mark the cylinder number on the valve and the parts to prevent interchanging.

**VALVE INSTALLATION**

1. Apply oil to the stem of valve and install it into the cylinder head.
2. Lubricate the valve and its related parts after installation.

**VALVE RECESS CHECK**

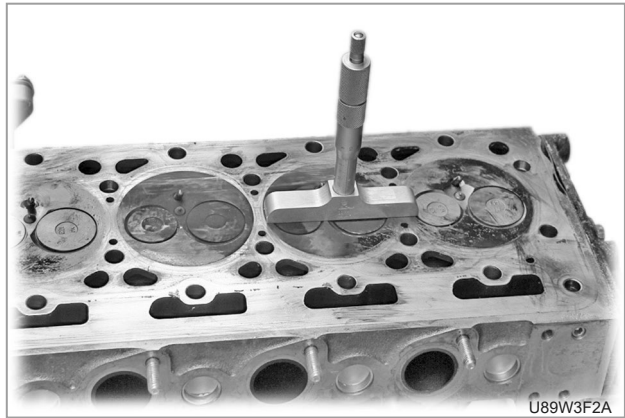

1. Clean the cylinder head, the valve face and the valve seat.
2. Insert the valve into the valve guide.
3. Measure the valve recess with a depth gauge.
4. If the recess value exceeds the allowable limit, replace the valve and check the valve seat.

Valve recess	Specified value	0.2 ~ 0.5 mm 0.0078 ~ 0.0197 in.
	Allowable limit	0.8 mm 0.0315 in.

SAFETY FIRST

ENGINE

DRIVING & CHASSIS

HYDRAULIC SYSTEM

ELECTRIC SYSTEM

CABIN

INDEX

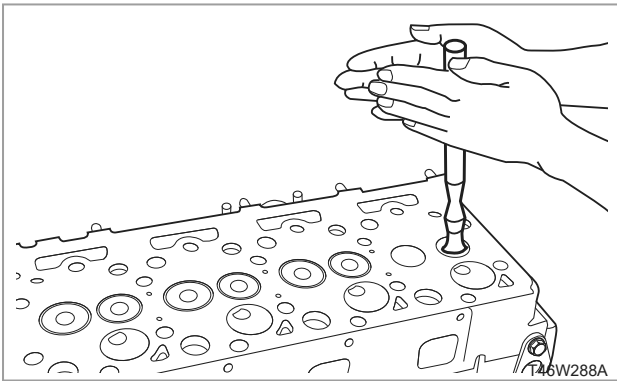
**VALVE SEAT CHECK**

1. Coat the valve face lightly with red lead and put the valve on its seat to check the contact.
2. If the valve does not seat all the way around the valve seat or the valve contact is less than 70%, correct the valve seating as follows.
3. Apply compound on the valve face evenly.
4. Put the valve on its seat and hold it with the valve flapper.
5. Turn the valve back and forth on the valve seat to lap.
6. Remove the compound and clean the valve and the seat.
7. Apply oil on the valve face and finish to complete fitting.
8. Repeat lapping until the valve seats correctly.

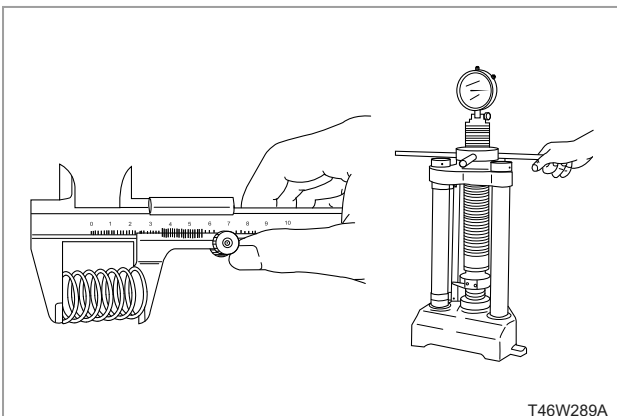
**VALVE SPRING CHECK**

1. Measure the free length of the spring with vernier calipers.
2. Place the spring on a spring compression tester and compress to the specified length to measure the tension.
3. If the measured value is less than the allowable limit, replace the valve spring.

Tension	Specified value	117 N / 35.15 mm 12.0 kgf / 35.15 mm 26.5 lbs / 1.3839 in.
	Allowable limit	100 N / 35.15 mm 10.2 kgf / 35.15 mm 22.5 lbs / 1.3839 in.
Free length	Specified value	41.7 ~ 42.2 mm 1.6417 ~ 1.6614 in.
	Allowable limit	41.2 mm 1.622 in

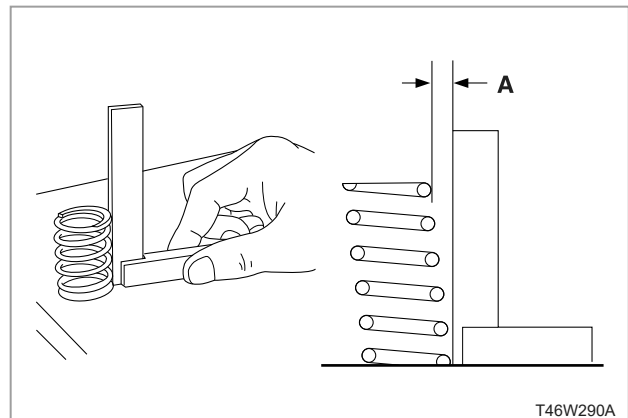
**VALVE SPRING SQUARENESS (TILT)**

1. Place the spring on the flat plate and then put a square at its side.
2. Measure the maximum distance "A" while rotating the spring.
3. If the measurement exceeds the allowable limit, replace the spring.

Valve spring squareness	Allowable limit	1.0 mm 0.039 in.
-------------------------	-----------------	---------------------

7.4.6 HIGH PRESSURE FUEL PUMP

**PUMP REMOVAL**

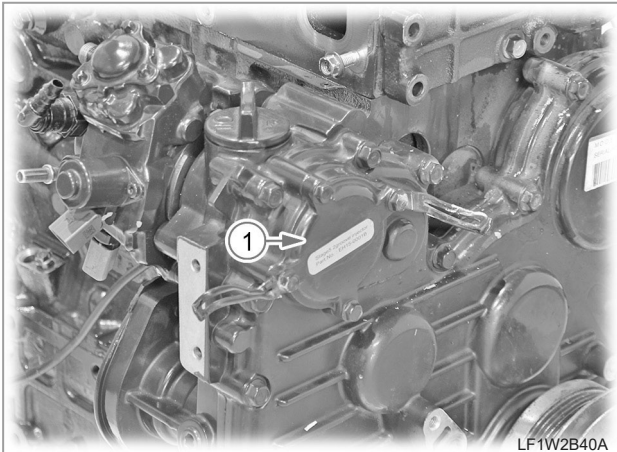

1. Remove the cover (1) of the gear case on the high-pressure fuel pump gear side.

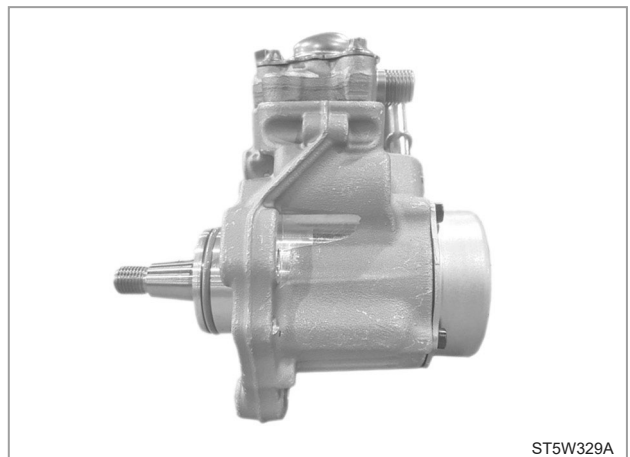
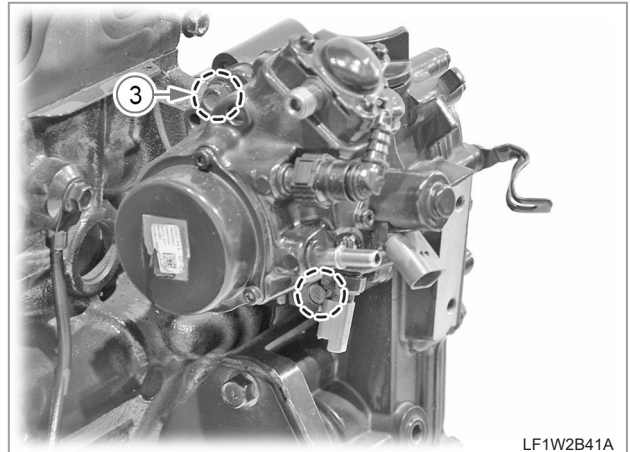

3. Unscrew the high-pressure fuel pump mounting bolts (3) to remove the high-pressure fuel pump assembly.

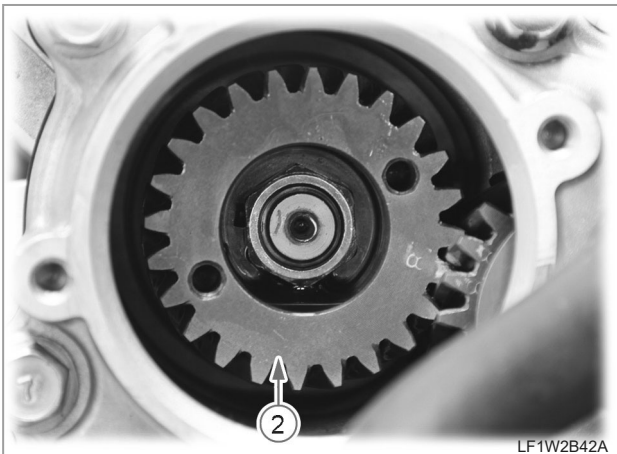

2. Remove the high-pressure fuel pump gear (2) from the gear case.

**Mounting nut**

tightening torque..... 68.6 ~ 78.4 Nm  
 7 ~ 8 kgf-m  
 50.4 ` 57.6 lb-ft

**Mounting nut**

tightening torque..... 23.5 ± 27.4 Nm  
 2.4 ± 2.8 kgf-m  
 17.3 ± 20.2 lb-ft

## 7.4.7 GEAR CASE

## REMOVAL

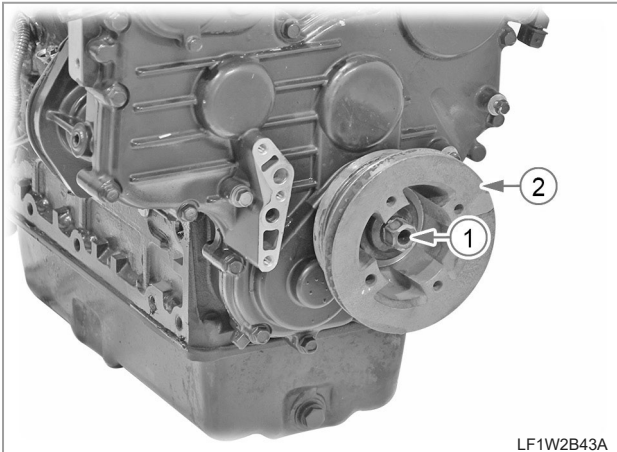

1. Unscrew the crankshaft mounting bolt (1) to remove the fan drive pulley (2).

**Crankshaft bolt**

tightening torque..... **320.5 ~ 343.0 Nm**  
**32.7 ~ 35.0 kgf-m**  
**235.4 ~ 252.0 lb-ft**

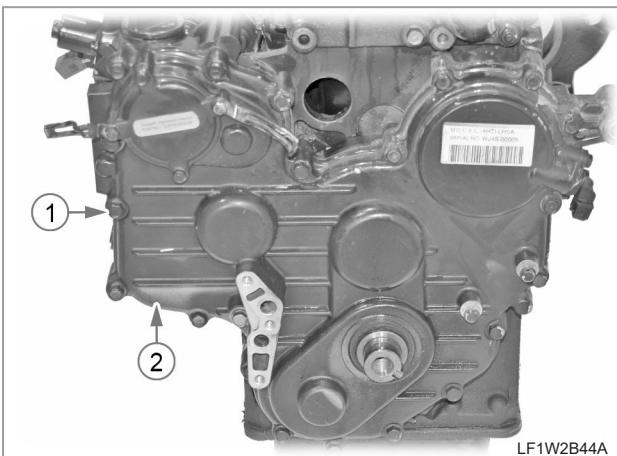

2. Unscrew the gear case cover mounting bolts (1) to remove the gear case cover (2).

**Mounting bolt**

tightening torque..... **23.5 ~ 27.4 Nm**  
**2.4 ~ 2.8 kgf-m**  
**17.3 ~ 20.2 lb-ft**

## INSTALLATION

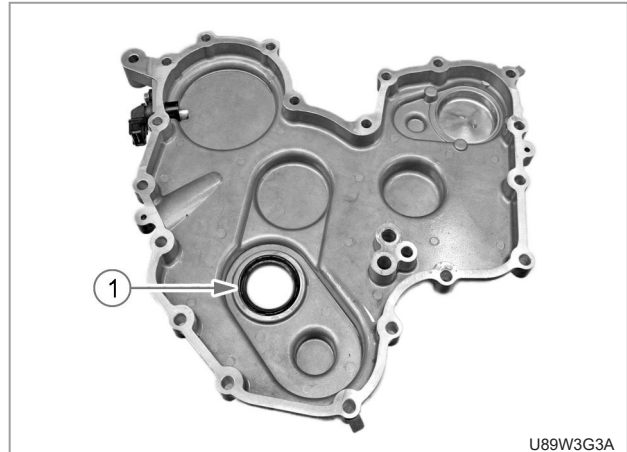

1. Apply the grease to the crankshaft oil seal (1) lip on the gear case cover and take care not to damage it when installing.
2. Make sure that the gear case cover mounting bolts are installed at correct locations.

**! IMPOARTANT**

- In general, the bolt should be screwed as 1.5 times as the diameter of the bolt in length.

3. Install all bolts and increase the tightening torque gradually (in 2 to 3 steps).

**M8 tightening torque... 23.5 ~ 27.4 Nm**  
**2.4 ~ 2.8 kgf-m**  
**17.3 ~ 20.2 lb-ft**

7.4.8 GEARS IN GEAR CASE

**REMOVAL**

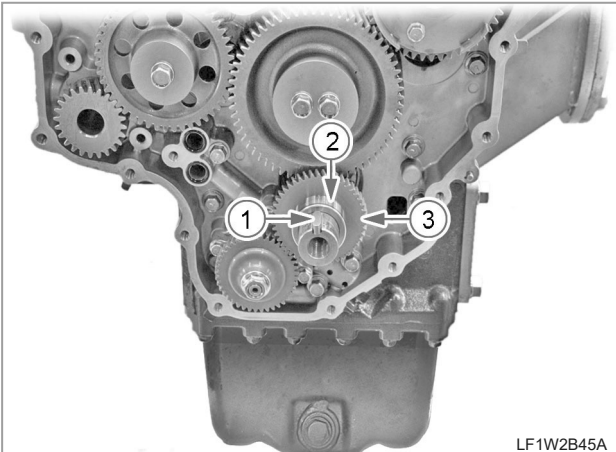

1. Pull out the crankshaft key (1) and remove the spacer (2) and oil pump drive gear (3).

**REMARKS**

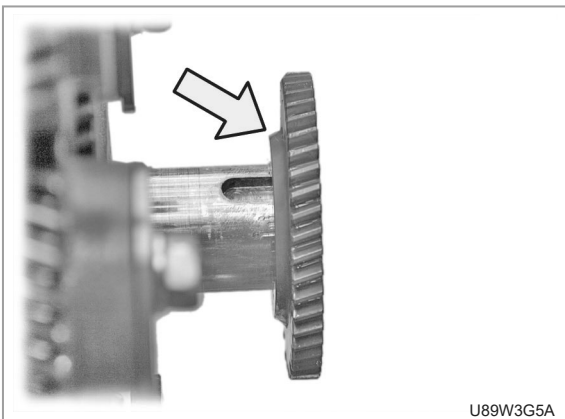

- When installing the oil pump drive gear, have its boss set toward the inside.

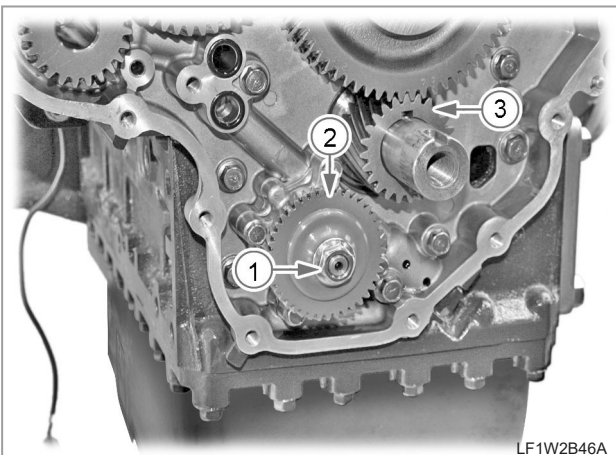

2. Unscrew the oil pump gear mounting nut (1) to remove the oil pump gear (2).

**REMARKS**

- The crankshaft gear (3) should be removed with a special puller when necessary. When installing the crankshaft gear, heat it to approx. 80°C (176°F) and insert it into the crankshaft.

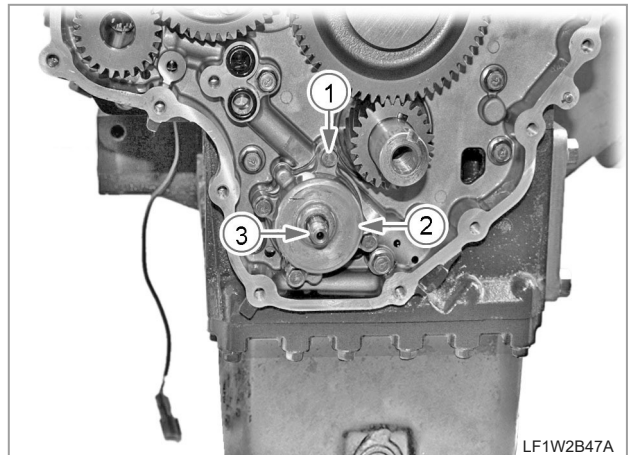

3. Unscrew the oil pump cover mounting bolts (1) to remove the oil pump cover (2) and oil pump rotor shaft (3) together.

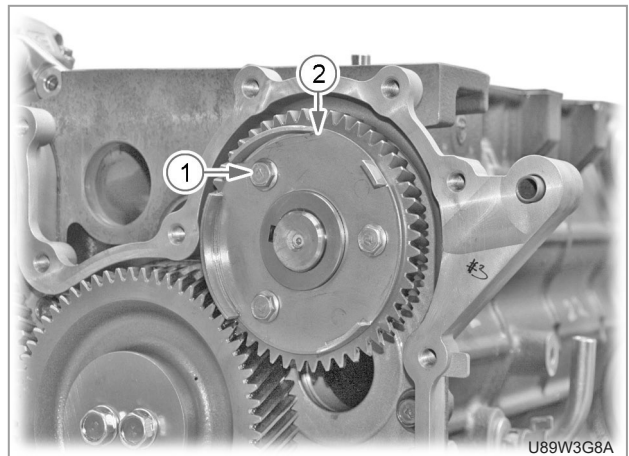

4. Unscrew the camshaft sensor wheel mounting bolts (1) to remove the camshaft sensor wheel (2).

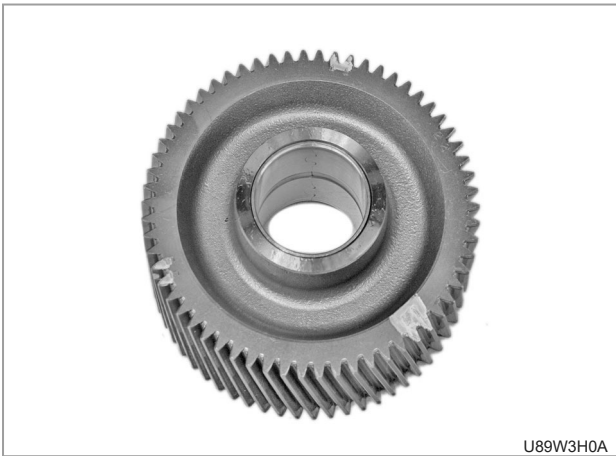
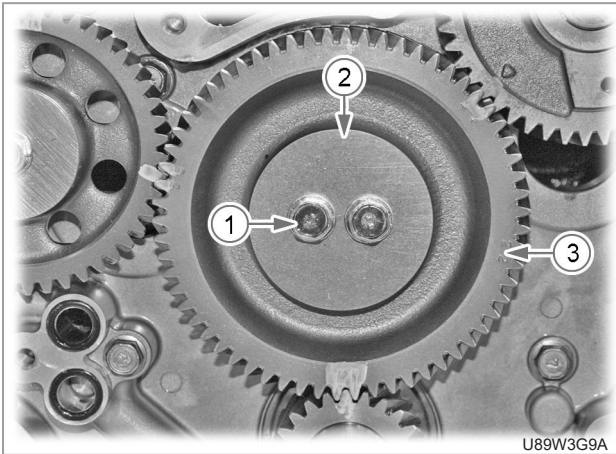

5. Unscrew the idle gear 1 mounting bolts (1) to remove the stopper (2) and idle gear assembly (3) in order.

### ! IMPOARTANT

#### ALIGNMENT OF GEARS IN GEAR CASE

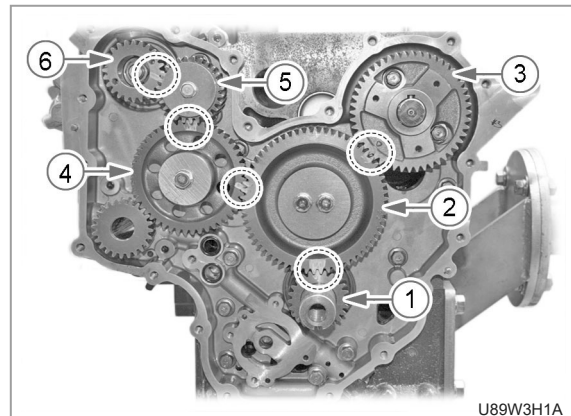

- |                     |                                  |
|---------------------|----------------------------------|
| (1) Crankshaft gear | (4) Idle gear 3                  |
| (2) Idle gear 1     | (5) Idle gear 4                  |
| (3) Camshaft gear   | (6) High-pressure fuel pump gear |

- There is a mark on a tooth of each gear in the gear case for alignment. If these marks are not aligned during gear installation, the engine can malfunction. Make sure to align all marks on the gears as illustrated when installing the idle gear.

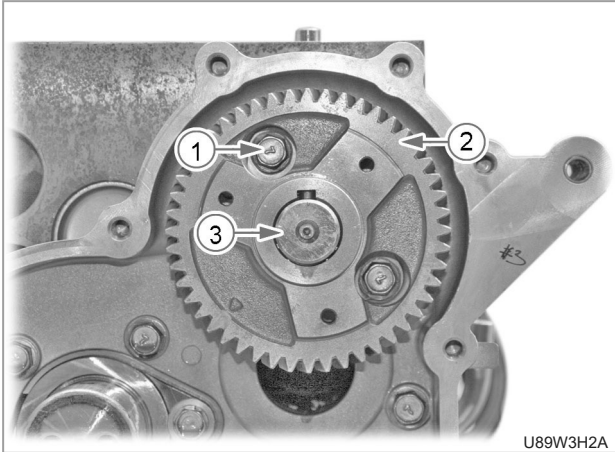

U89W3H2A

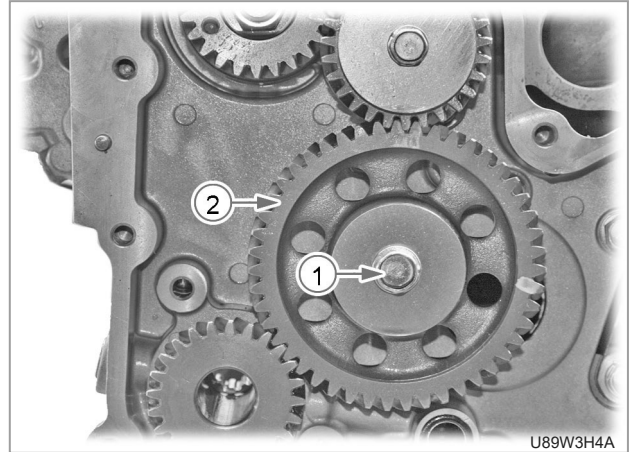

U89W3H4A

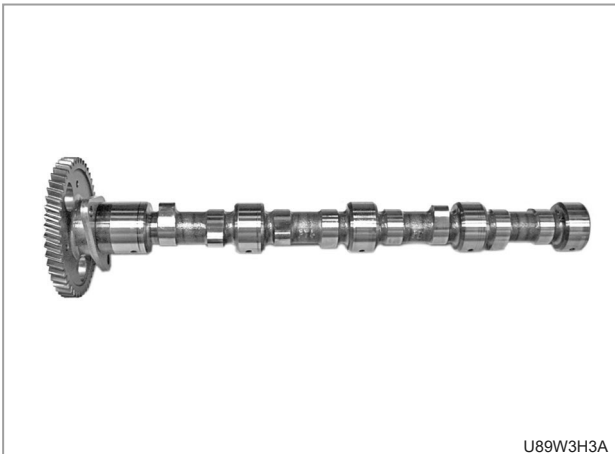

U89W3H3A

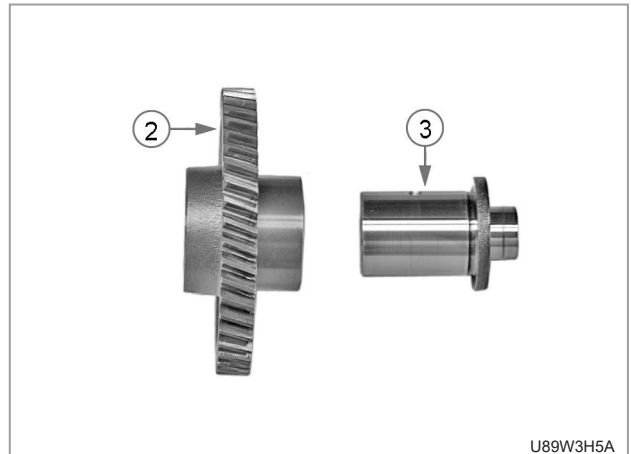

U89W3H5A

6. Unscrew the camshaft stopper mounting bolts (1) to remove the camshaft gear (2) and camshaft (3) together.

7. Unscrew the idle gear 3 stopper mounting bolt (1) to remove the idle gear 3 (2) and idle gear 3 shaft (3).

**REMARKS**

- When necessary, remove the camshaft gear (2) with a special puller. When installing it, heat it to approx. 80°C (176°F) and insert it into the crankshaft.

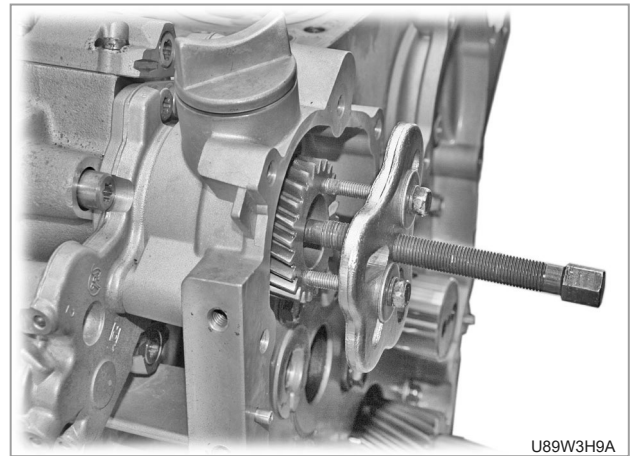
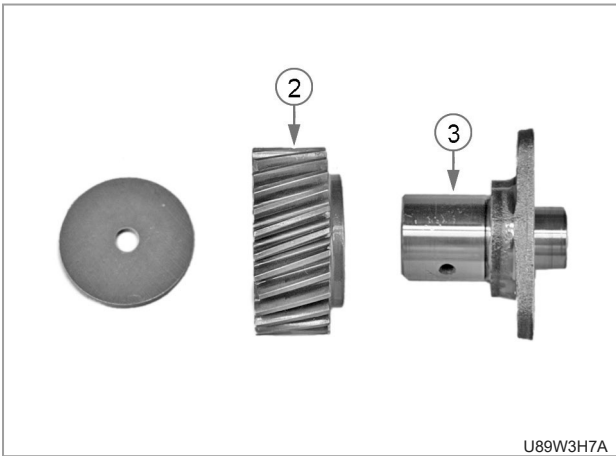
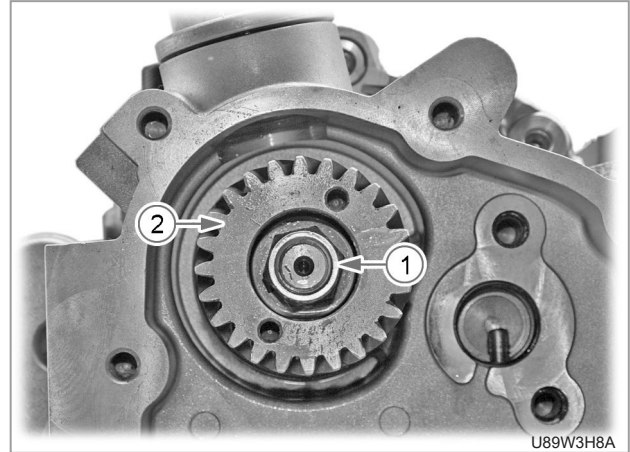
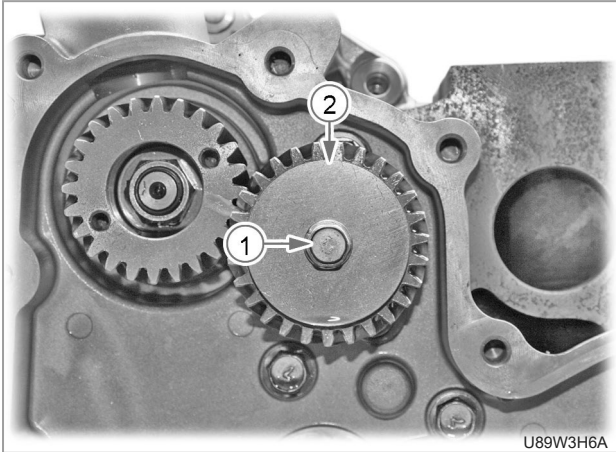

8. Unscrew the idle gear 4 stopper mounting bolt (1) to remove the idle gear 4 (2) and idle gear 4 shaft (3).



9. Unscrew the high-pressure fuel pump gear mounting nut (1) and remove the high-pressure fuel pump gear (2) with a special puller.



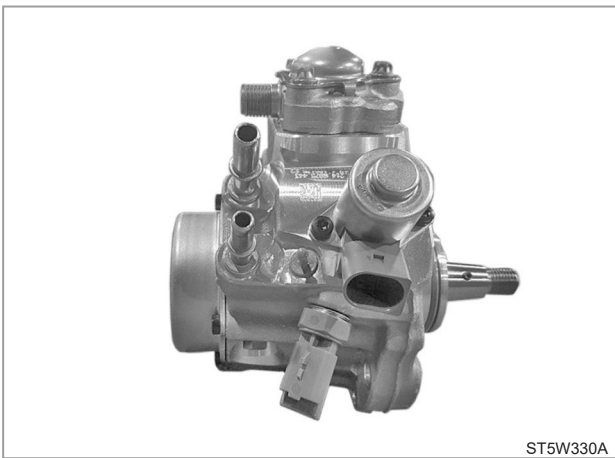
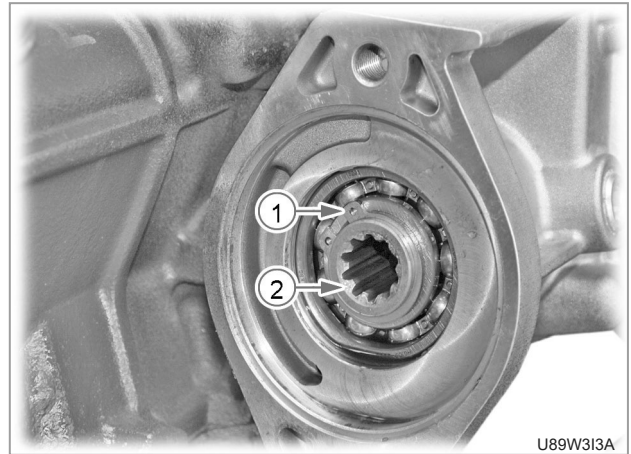
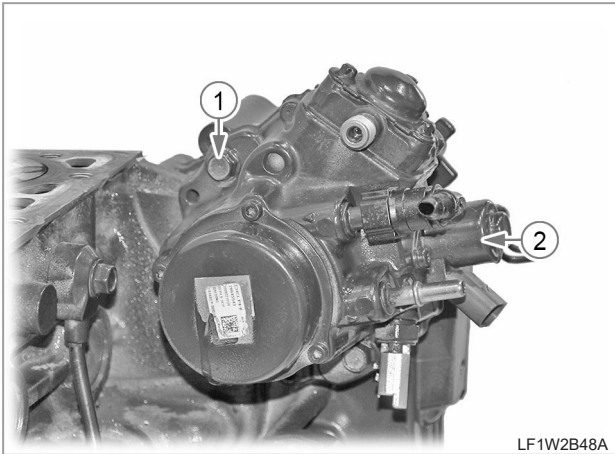

10. Unscrew the high-pressure fuel pump mounting bolts (1) to remove the high-pressure fuel pump assembly (2).

11. Pull out the hydraulic pump drive gear mounting snap ring (1) to remove the hydraulic pump drive gear (2).

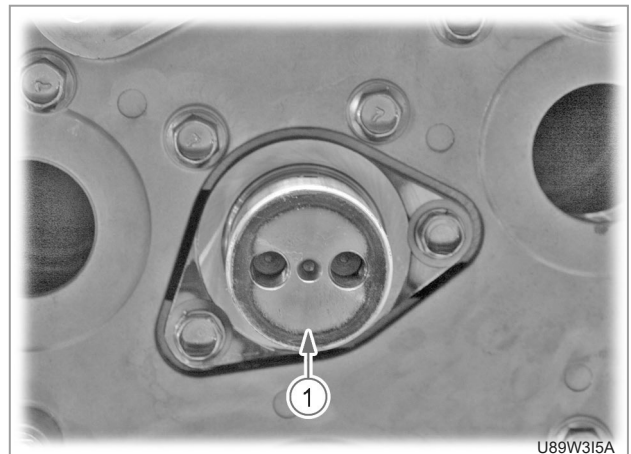

12. Remove the idle gear 1 shaft (1).

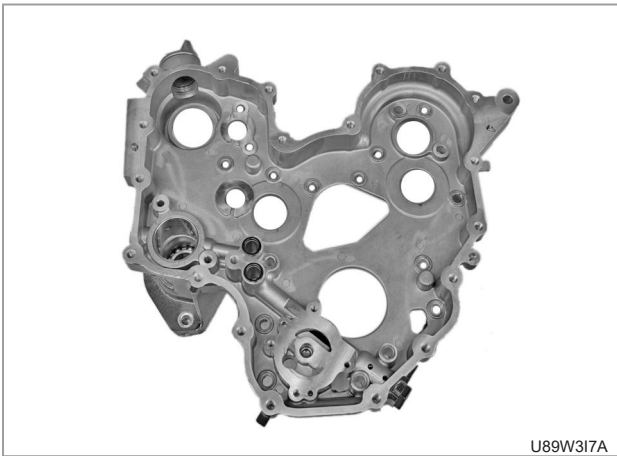
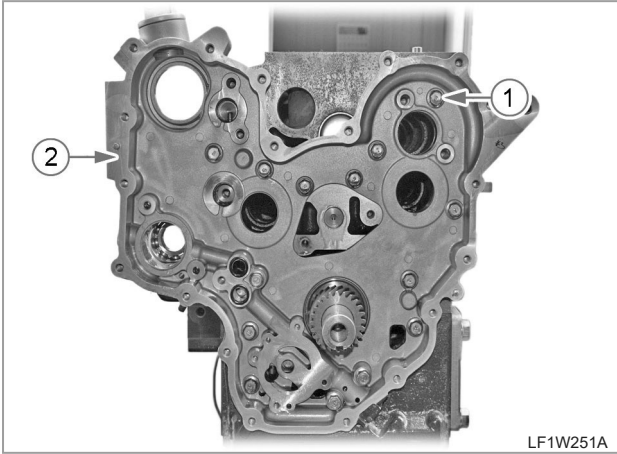

13. Unscrew the gear case mounting bolts (1) (14 EA) to remove the gear case assembly (2)

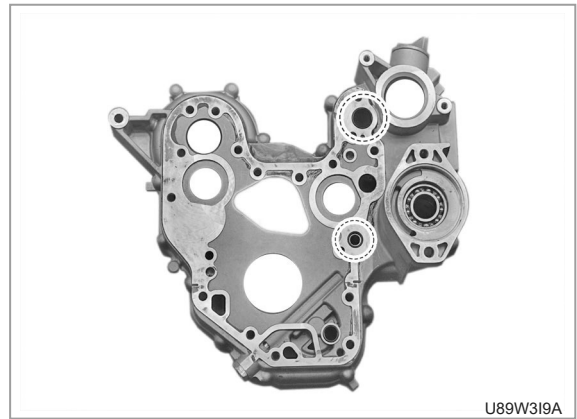

14. If necessary, remove the relief valve.

**REMARKS**

- Apply liquid gasket (LOCTITE #5902, #5900 or equivalent) to the mating surface of the gear case on the cylinder block side before installing the gear case.
- Make sure that the O-ring is installed (sections with dotted circles) before installing the gear case. If any faulty O-ring is detected, install a new one and apply a proper amount of gear or engine oil on it.

**CRANK GEARS AND SHAFTS CHECK**

► **IDLE GEAR & CAM SHAFT GEAR BACKLASH**

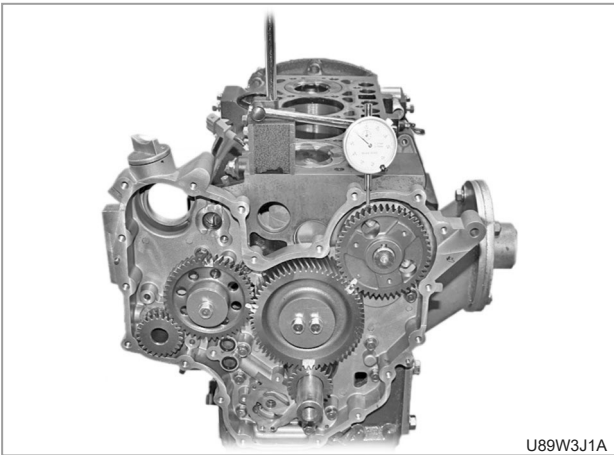
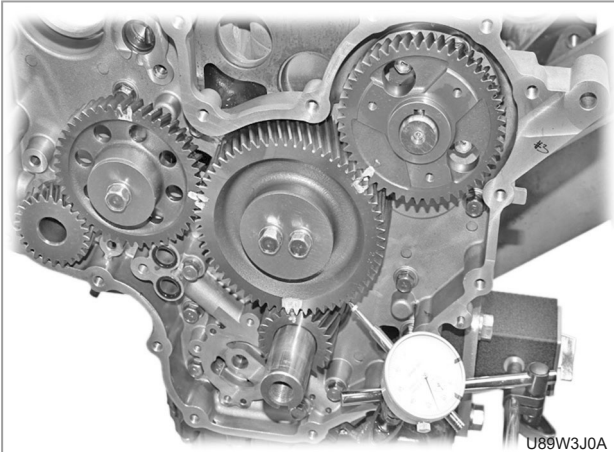

1. Set a dial indicator (lever type) with its tip on the gear tooth.
2. Move the idle gear and camshaft gear to measure its backlash while holding the engaged gear to it.
3. If the backlash exceeds the allowable limit, check the oil clearance of the shafts and the gear. (See next page)
4. If the oil clearance is OK but the backlash is over the allowable limit, replace the gear.

Backlash	Specified value	0.04 ~ 0.11mm 0.0016 ~ 0.0043 in.
	Allowable limit	0.15 mm 0.0059 in.

► **IDLE GEAR SIDE CLEARANCE**

1. Install the dial gauge to be in contact with the gear surface. Then, measure the clearance while pushing and pulling the gear. (Refer to the measurement method of the valve camshaft gear side clearance below.)
2. If the clearance exceeds the allowable limit, replace the idle gear.

Side clearance	Specified value	0.20 ~ 0.51 mm 0.0079~ 0.0201 in.
	Allowable limit	0.9 mm 0.035 in.

► **VALVE CAMSHAFT GEAR SIDE CLEARANCE**

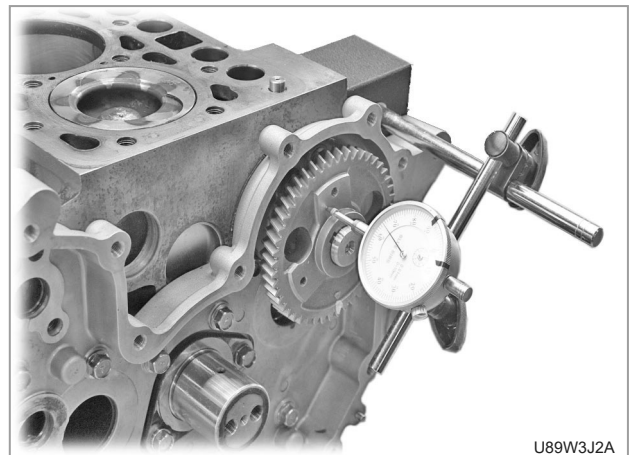

1. Install the dial gauge so that its sensor tip is in contact with the camshaft gear surface slightly.
2. Pull the camshaft gear to measure the side clearance.
3. If the clearance exceeds the allowable limit, replace the camshaft stopper.

Side clearance	Specified value	0.07 ~ 0.22 mm 0.0028 ~ 0.0087 in.
	Allowable limit	0.3 mm 0.0118 in.

### ► IDLE GEAR OIL CLEARANCE MEASUREMENT

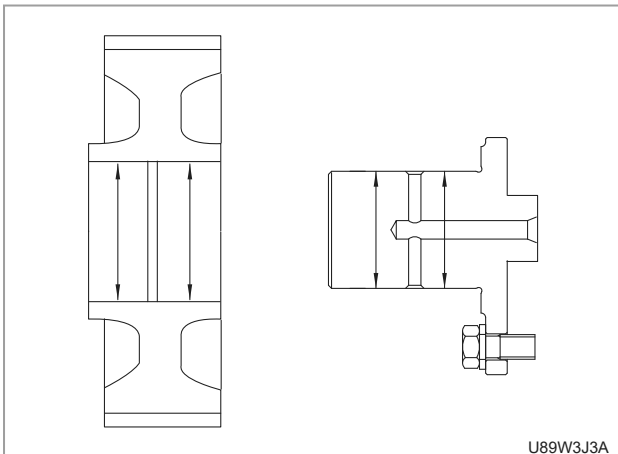

U89W3J3A

1. Measure the idle gear shaft O.D. with an outside micrometer.
2. Measure the idle gear bushings I.D. with an inside micrometer.
3. If the clearance exceeds the allowable limit, replace the bushing.

Oil clearance	Specified value	0.025 ~ 0.066 mm 0.00098 ~ 0.00259 in.
	Allowable limit	0.1 mm 0.004 in.
Shaft O.D.	Specified value	42.959 ~ 42.975 mm 1.69130 ~ 1.69193 in.
Bushing I.D.	Specified value	43.000 ~ 43.025 mm 1.69291 ~ 1.69390 in.

### ► VALVE CAMSHAFT OIL CLEARANCE MEASUREMENT

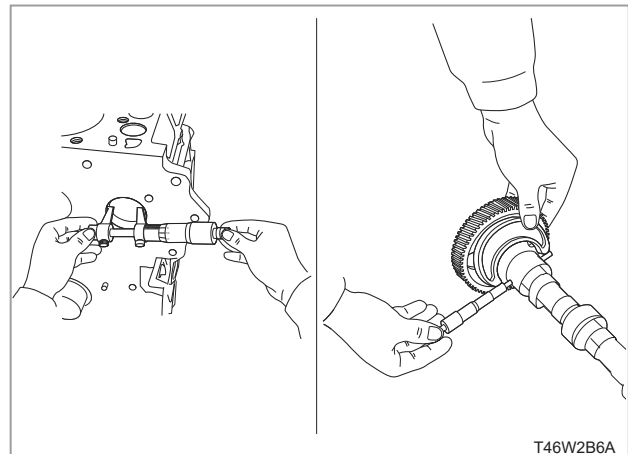

T46W2B6A

1. Measure the I.D. of the camshaft bore on the crankcase with an inside micrometer.
2. Measure the O.D. of the camshaft journal with an outside micrometer.
3. If the clearance exceeds the allowable limit, replace the shaft.

Oil clearance	Specified value	0.050 ~ 0.091mm 0.00197 ~ 0.00358 in.
	Allowable limit	0.15 mm 0.0059 in.
Journal O.D.	Specified value	39.934 ~ 39.950 mm 1.57221 ~ 1.57284 in.
Bore I.D.	Specified value	40.000 ~ 40.025 mm 1.57480 ~ 1.57579 in.

### ► IDLE GEAR BUSHING REPLACEMENT

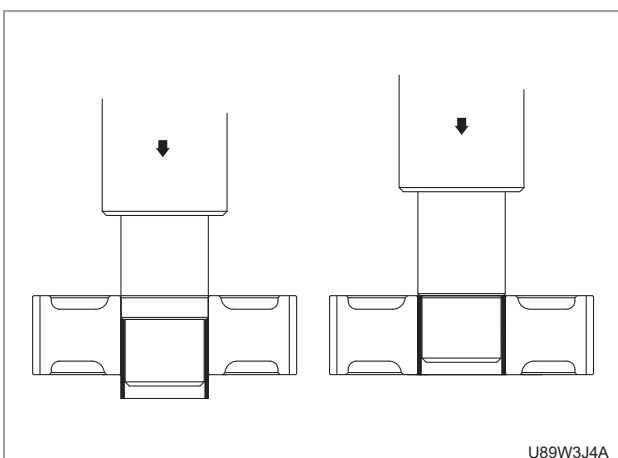

U89W3J4A

1. Press out the bushing using replacing tool.
2. Clean the bore, and apply the oil on it.
3. Press in the new bushing using the replacing tool.

► VALVE CAMSHAFT DEFLECTION CHECK

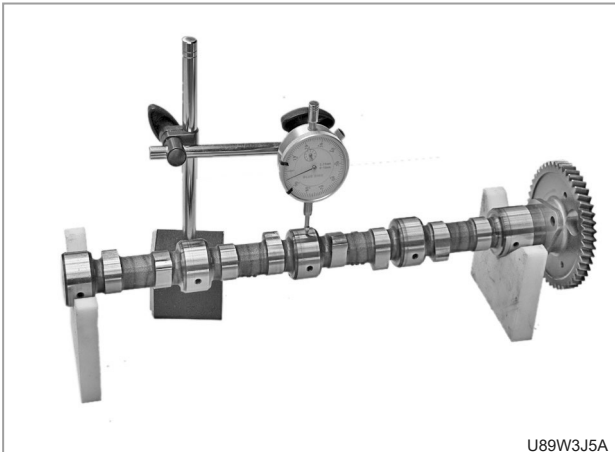

1. Place the camshaft on V blocks with its journals supported and set a dial indicator with its tip on the intermediate journal.
2. Measure the eccentricity (half of the measured value) while turning the camshaft on the V blocks.
3. If the eccentricity exceeds the allowable limit, replace the camshaft.

Eccentricity	Allowable limit	0.05 mm 0.002 in.
--------------	-----------------	----------------------

► VALVE CAM HEIGHT MEASUREMENT

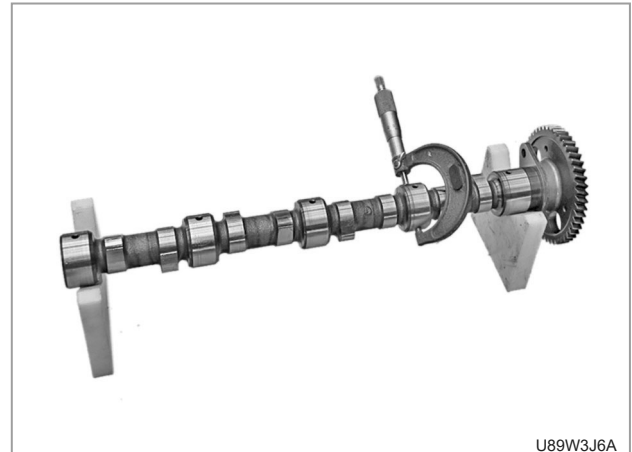

1. Measure the height of the camshaft lobe at largest O.D. with an outside micrometer.
2. If the measured value is below the allowable limit, replace the camshaft.

Cam height	IN.	Specification	33.59 mm 1.322 in.
		Allowable limit	33.54 mm 1.320 in.
	EX.	Specification	33.69 mm 1.326 in.
		Allowable limit	33.64 mm 1.324 in.

## 7.4.9 PISTON AND CONNECTING ROD

## REMOVAL

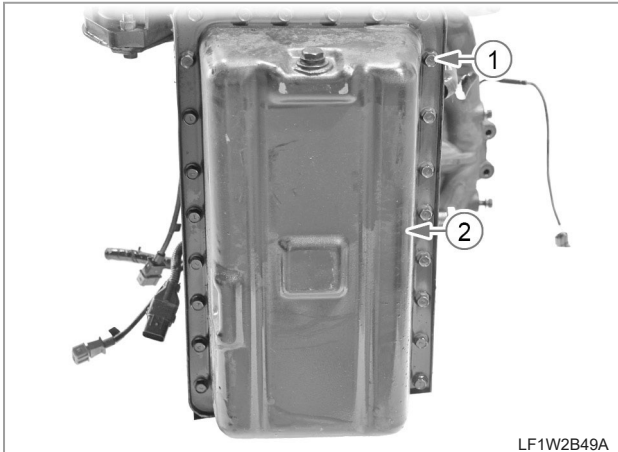

1. With the engine block body supported, unscrew the oil pan mounting bolts (1) (26 EA) and remove the oil pan (2).

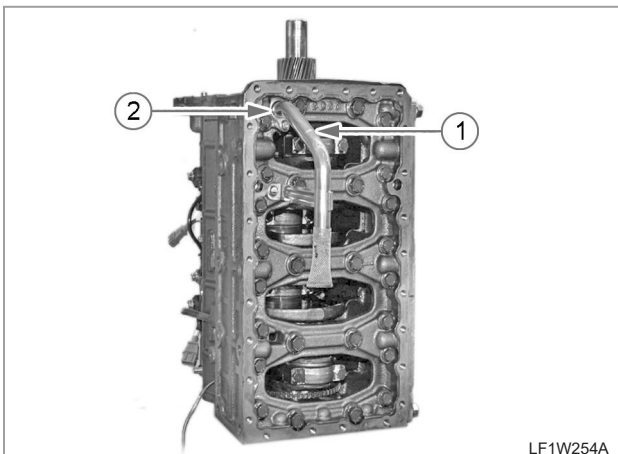

2. Remove the oil strainer assembly (1).

**CAUTION**

- When installing the oil strainer to the cylinder block, make sure to check the O-ring (2) on the mounting section.

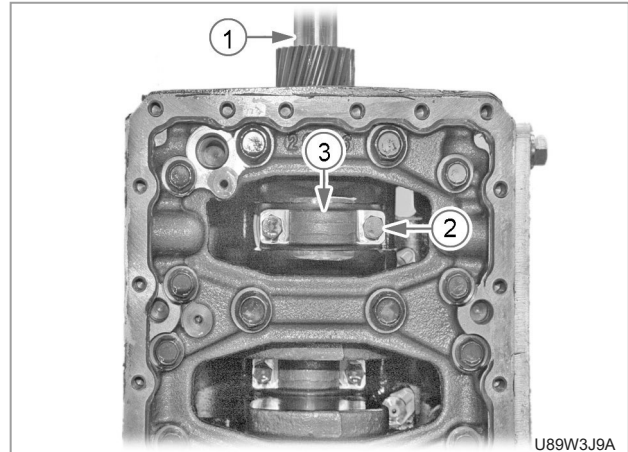

3. Turn the crankshaft (1) to set the connecting rod cap to the lower side. Then, unscrew the connecting rod bolts (2) of each cylinder to remove the connecting rod cap (3).

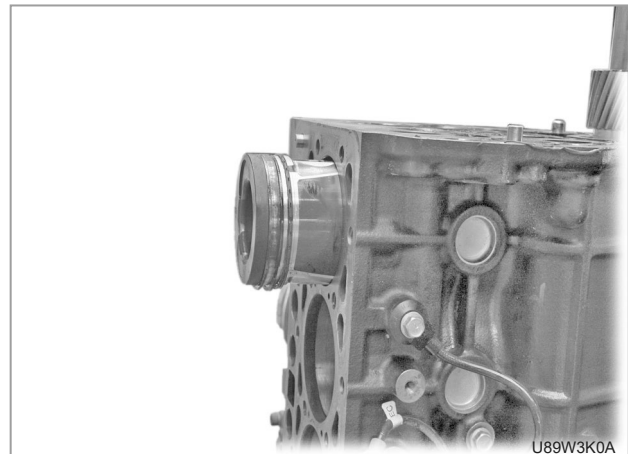

4. Turn the crankshaft again to set the piston to the top of the engine block. Then, tap the connecting rod with a rubber hammer to remove the piston out of the cylinder block.

**! IMPOARTANT**

- When removing the pistons, mark their installing positions by each cylinder so that they can be installed to their original positions later.

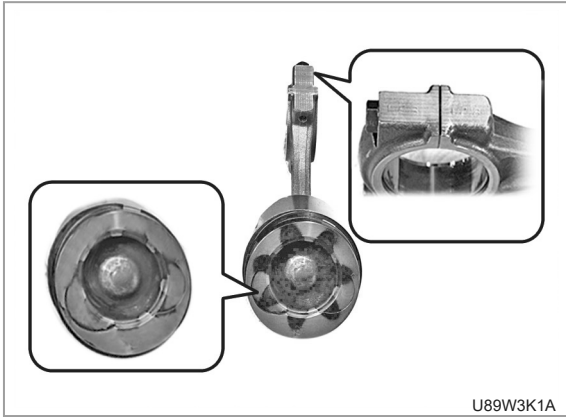

- When installing the piston and connecting rod, the combustion chamber groove of the piston head and the mark on the connecting rod should be set symmetrically.
- When installing the piston and connecting rod assembly to the cylinder block, set the mark on the connecting rod toward the high-pressure pump.

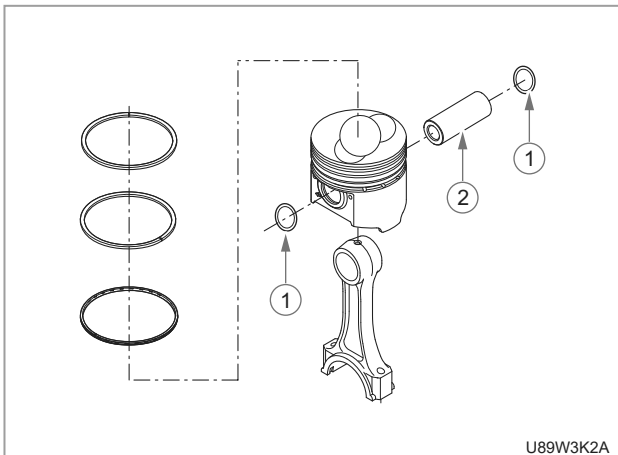

5. Remove the piston rings with a piston ring replacing tool.
6. Remove the piston pin snap ring (1) and then remove the piston pin (2).

**INSTALLATION**

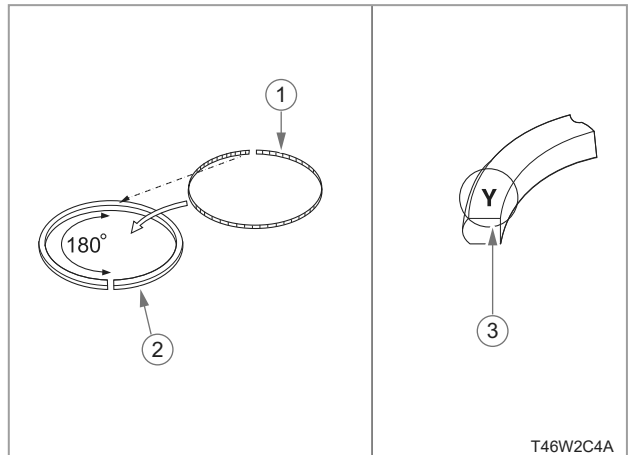
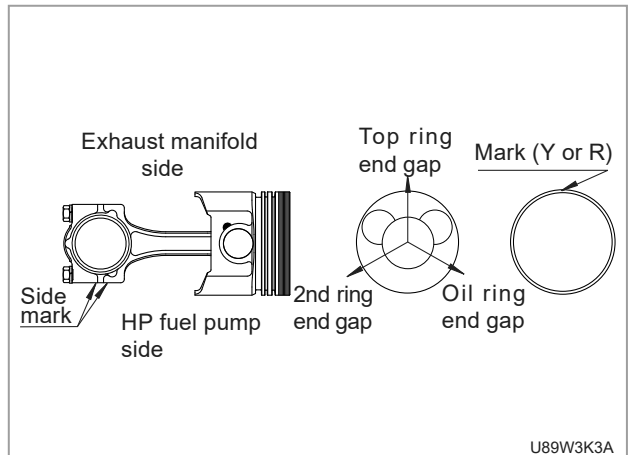

1. Clean all the parts before installation.
2. Warm up the piston by soaking it in hot oil (approx. 80 °C) for 10 to 15 minutes before inserting the piston pin into the piston.
3. With the casting marks on the connecting rods aligned vertically, set them toward the high-pressure pump and install the piston and connecting rod so that they are 180 degrees away from the combustion chamber groove on the piston head.
4. The manufacturer mark (Y or R) (3) on the top ring should face the top of the piston.
5. The cutout of expander (1) should face the opposite side of the oil ring (2) end gap.
6. The top ring end gap ring should be on the opposite side of the combustion chamber on piston.
7. The 2nd ring end gap and the oil ring end gap should be 120° far from the top ring end gap.

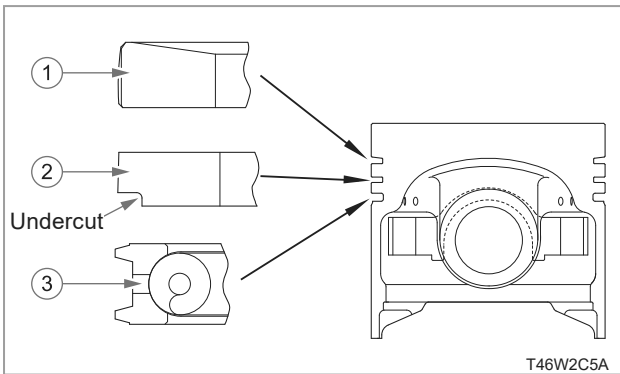

(1) Top ring (2) 2nd ring (3) Ring

8. Make sure that the undercut of the 2nd ring faces downward.
9. Apply the oil on the crankpin bearing, cylinder wall and connecting rod cap screw.

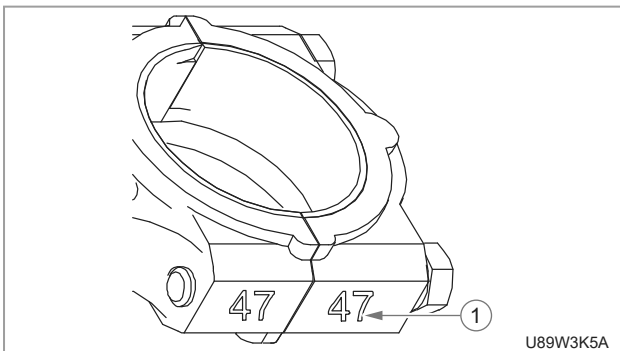
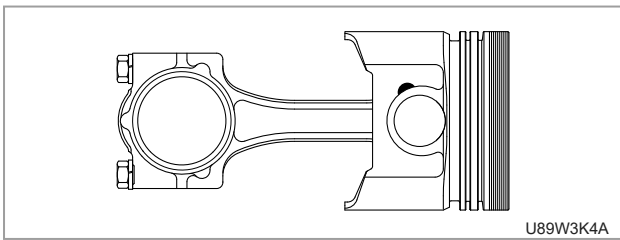

10. Insert the connecting rod and piston assembly with the stamped number (1) on the connecting rod facing the high pressure fuel pump using a piston ring compressor.
11. Apply the engine oil to the connecting rod cover bolts and hand tighten them all the way down. Then, tighten them with a torque wrench. If they would not be tightened to the specified torque, replace the bolts. The both stamped numbers should be seen from one side.

**Connecting rod**

**cover bolt..... 44.1 ~ 49.0 Nm  
4.5 ~ 5.0 kgf-m  
32.5 ~ 36.1 lb-ft**

**! IMPOARTANT**

- Mark the cylinder number on the piston and connecting rod to prevent them from interchanging.
- Be careful not to damage the chrome-plate area on the piston ring when pressing the piston and ring assembly into the cylinder.

**PISTON AND CONNECTING ROD CHECK**

**► PISTON PIN BORE**

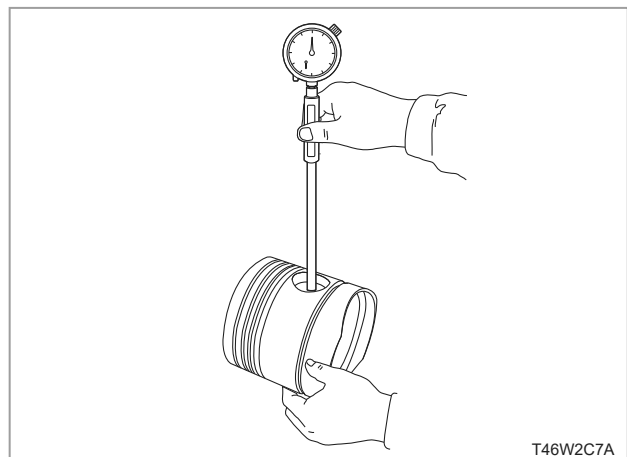

1. Measure the I.D. of piston pin bore (lengthwise and widthwise of the piston) with a cylinder gauge.
2. If the measured value exceeds the allowable limit, replace the piston.

Piston pin bore I.D.	Specified value	25.000 ~ 25.006 mm (0.9843 ~ 0.9845 in.)
	Allowable limit	25.03 mm (0.9854 in.)



► PISTON PIN AND BUSHING CLEARANCE

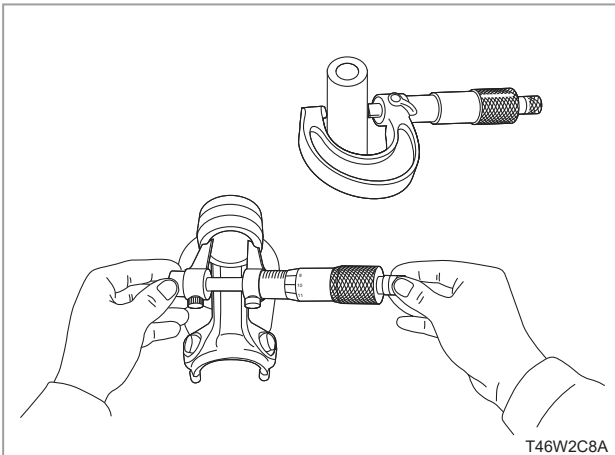

1. Measure the piston pin O.D. with an outside micrometer.
2. Measure the piston pin busing I.D. with an inside micrometer.
3. If the clearance still exceeds the allowable limit after replacing the bushing with new one, replace the piston pin.

Clearance between piston pin and bushing	Specified value	0.025 ~ 0.045 mm (0.00098 ~ 0.00177 in.)
	Allowable limit	0.05 mm (0.0020 in.)
Piston pin O.D.	Specified value	29.995 ~ 30.000 mm (1.18090 ~ 1.18110 in.)
Bushing I.D.	Specified value	30.025 ~ 30.040 mm (1.18209 ~ 1.18268 in.)

► PISTON PIN BUSHING REPLACEMENT

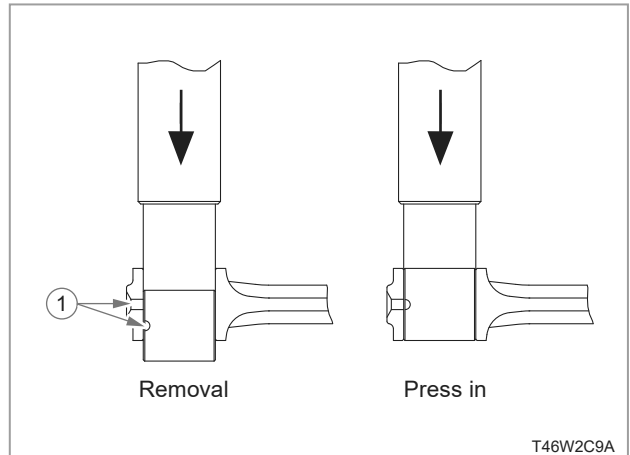

1. Press out the bushing using a bushing replacing tool.
2. Clean the new bushing and the bore and apply the oil to them.
3. Press in the bushing using the replacing tool.

**! IMPOARTANT**

- Align the oil holes (1) of the connecting rod and the bushing.

**PISTON RING MEASUREMENT**

**▶ PISTON RING END GAP**

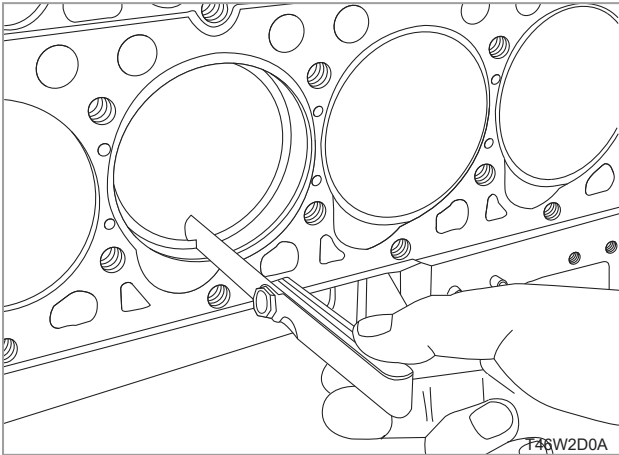

1. Place the piston ring to be measured on the top face of piston in cylinder block and slightly push in the piston and piston ring. (Do not put the piston ring on the carbon layer.)
2. Measure the ring end gap with a feeler gauge.
3. If the gap exceed the allowable limit, replace the piston ring.

Piston ring end gap	2nd ring	Specified value	0.40 ~ 0.55 mm (0.01575 ~ 0.02165 in.)
		Allowable limit	1.25 mm (0.0492 in.)
	Top ring, oil ring	Specified value	0.25 ~ 0.40 mm (0.00984 ~ 0.01575 in.)
		Allowable limit	1.25 mm (0.0492 in.)

4. If the gap is still over the allowable limit with even new ring, measure the diameter of bore (see page 3-137).

**▶ PISTON RING CLEARANCE**



1. Clean the ring and ring grooves, and install each ring in its groove.
2. Measure the clearance between the ring and the ring groove with a feeler gauge.
3. If the clearance exceeds the allowable limit, replace the piston ring.
4. If the clearance still exceeds the allowable limit after removing the ring with new one, replace the piston.

Piston ring clearance	2nd ring	Specified value	0.04 ~ 0.08 mm (0.00157 ~ 0.00314 in.)
		Allowable limit	0.15 mm (0.0059 in.)
	Oil ring	Specified value	0.02 ~ 0.06 mm (0.00079 ~ 0.00236 in.)
		Allowable limit	0.15 mm (0.0059 in.)

7.4.10 FLYWHEEL AND CRANKSHAFT

**REMOVAL**

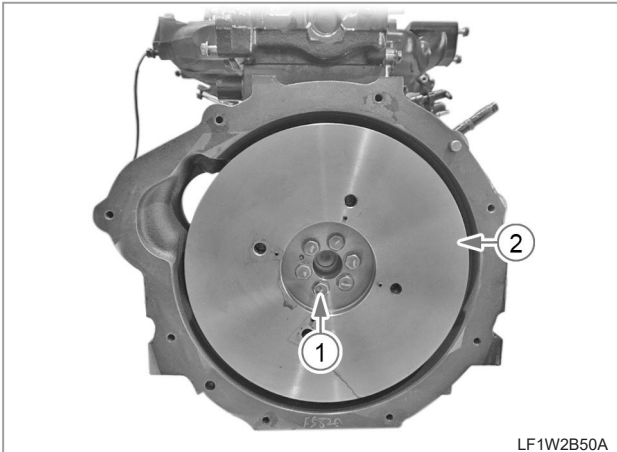

1. Unscrew the flywheel mounting bolts (1) to remove the flywheel (2).

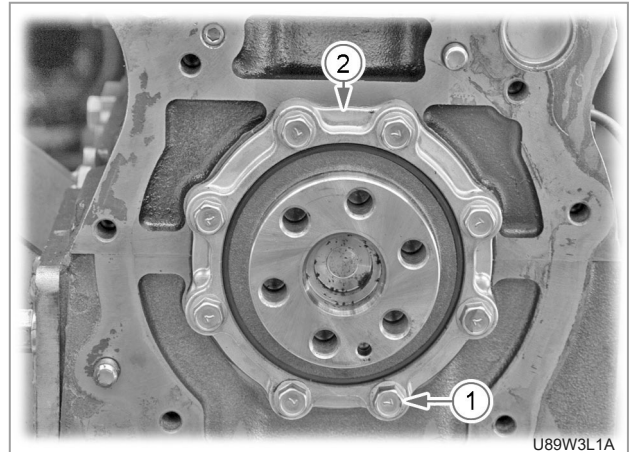

3. Unscrew the oil seal case mounting bolts (1) to remove the oil seal case (2).

**REMARKS**

- Use a crankshaft wrench or flywheel ring gear as a stopper to prevent the flywheel from rotating.

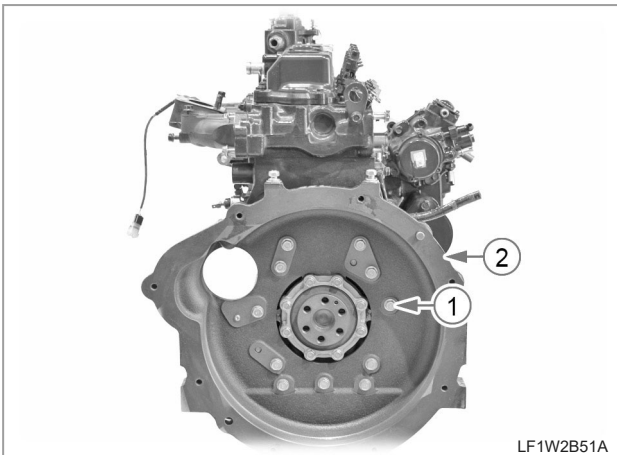

2. Unscrew the flywheel housing mounting bolts (1) (13 EA) to remove the flywheel housing (2).

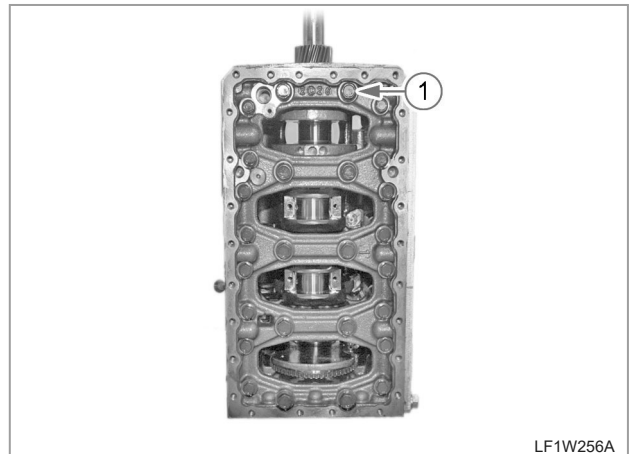

4. Unscrew the main bearing bolts (1) (10 EA) from the bottom of the cylinder block.

SAFETY FIRST

ENGINE

DRIVING & CHASSIS

HYDRAULIC SYSTEM

ELECTRIC SYSTEM

CABIN

INDEX

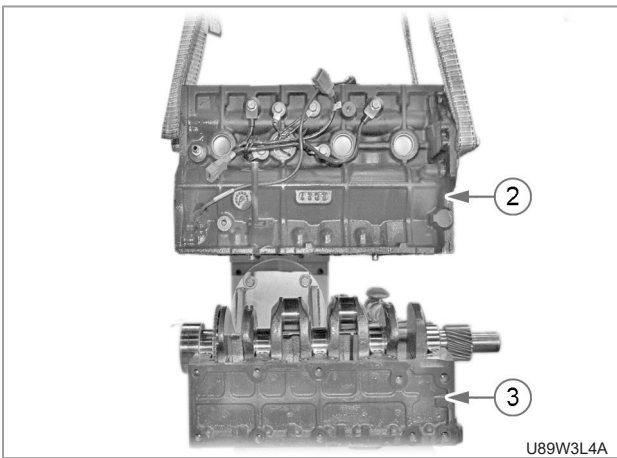
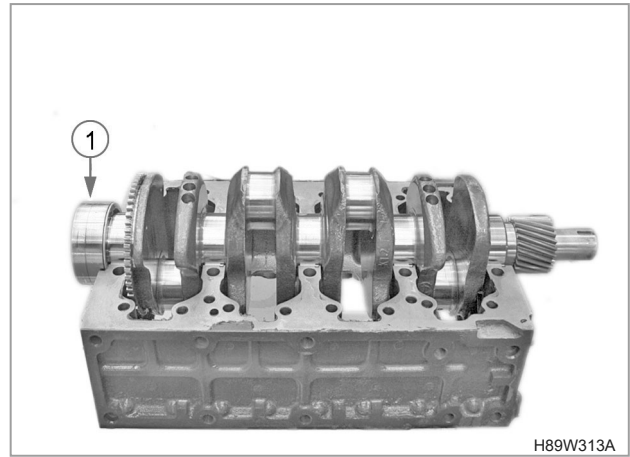
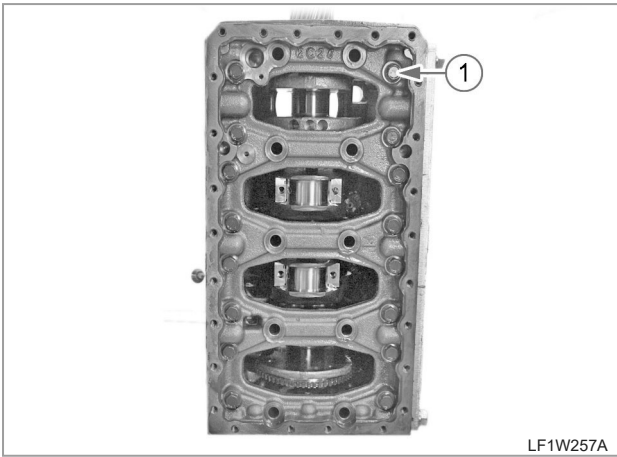

5. Unscrew the ladder frame mounting bolts (1) (16 EA) to remove the cylinder block (2) and ladder frame (3).

6. Remove the crankshaft assembly (1).

**INSTALLATION**

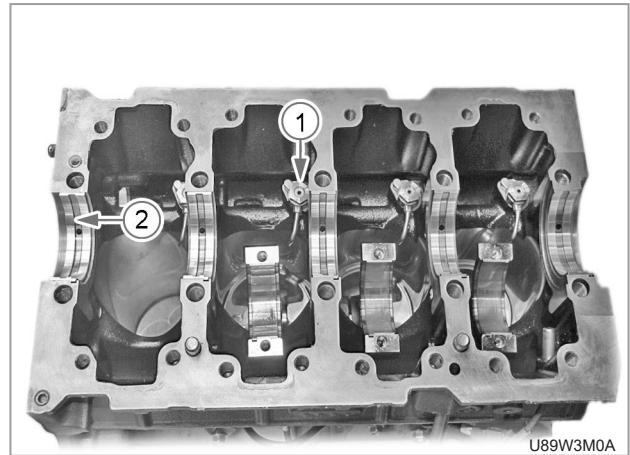
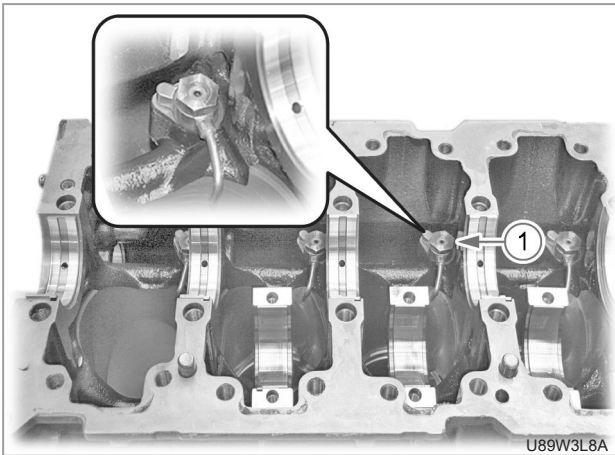

1. Install the piston cooling jet valve (1) to the cylinder block. Then, install the crankshaft bearing (upper) (2).



7. Remove the piston cooling jet valve (1) from the cylinder block as necessary.

**REMARKS**

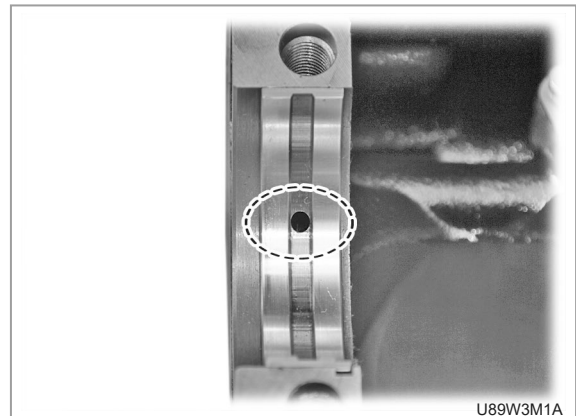

- The crankshaft bearing (upper) has an oil groove and hole on its center.

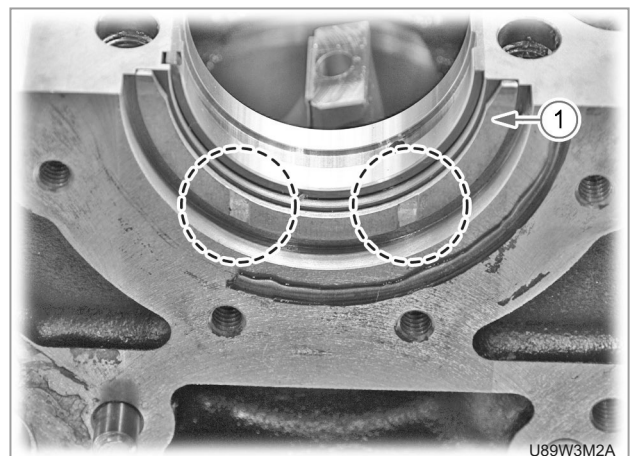

2. Install the crankshaft thrust bearing (upper) (1). Make sure to set its oil groove toward the outside.

 REMARKS

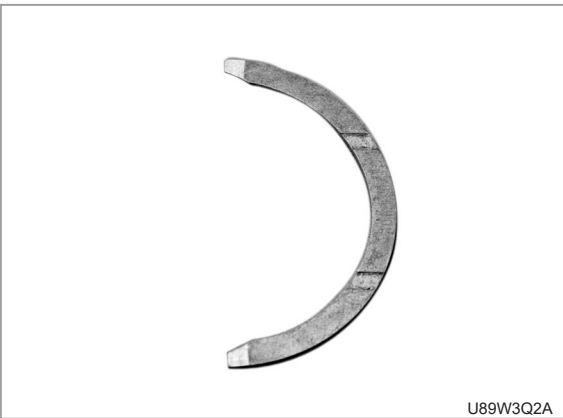

U89W3Q2A

- The crankshaft thrust bearing (upper) does not have any protruded section.

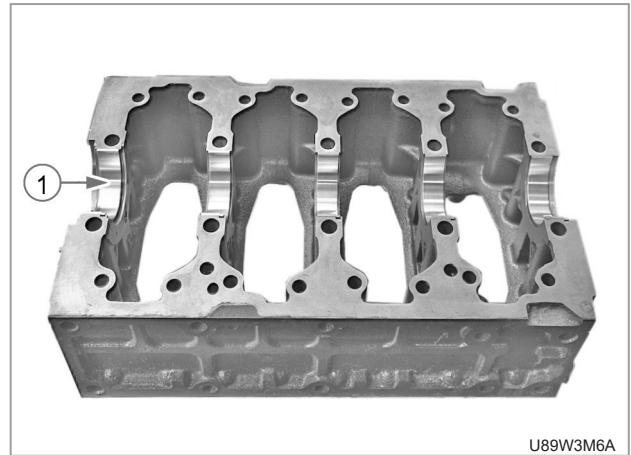

U89W3M6A

4. Install the crankshaft bearing (lower) (1) to the ladder frame..

 REMARKS

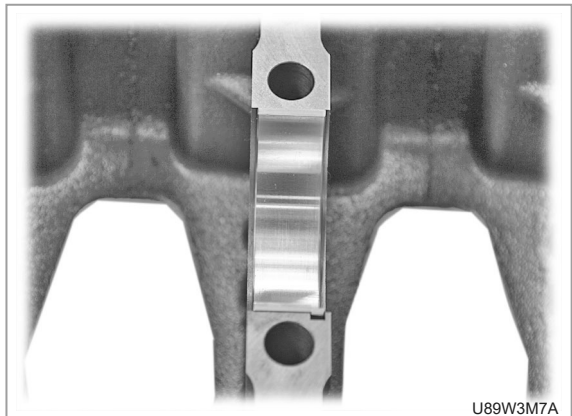

U89W3M7A

- The crankshaft bearing (lower) does not have any oil groove and hole on its center.

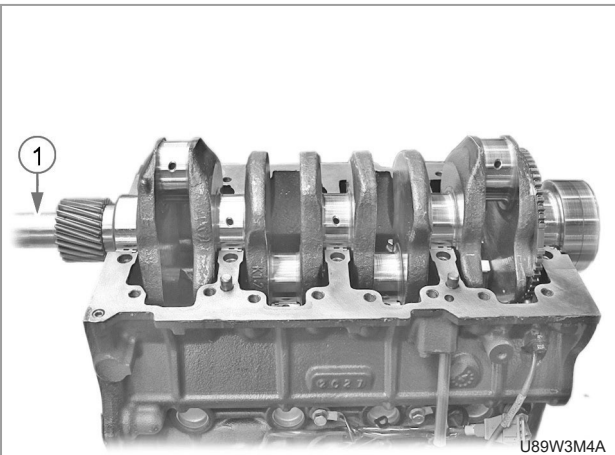

U89W3M4A

3. Apply engine oil to the crankshaft bearings (upper) of the cylinder block. Then, put the crankshaft (1) on it.

 REMARKS

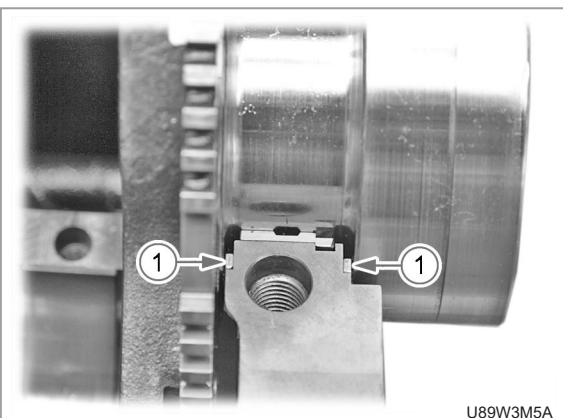

U89W3M5A

- Be careful not to lose the crankshaft thrust bearings (upper) (1) during installation of the crankshaft.

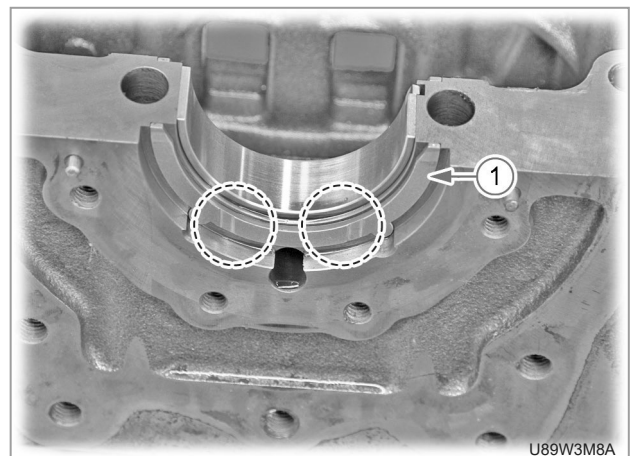

U89W3M8A

5. Install the crankshaft thrust bearing (lower) (1). Make sure to set its oil groove toward the outside.

REMARKS

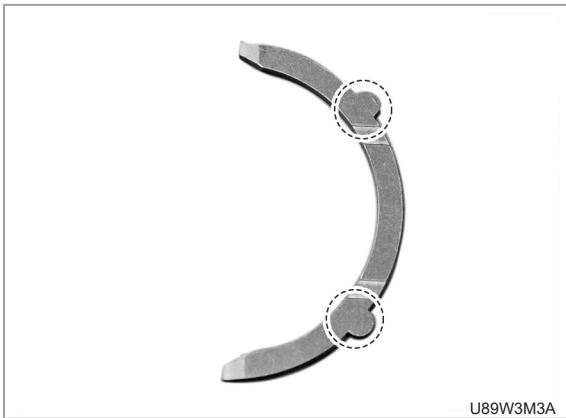

U89W3M3A

- The crankshaft thrust bearing (lower) has protruded sections.

6. Apply liquid gasket (LOCTITE #518 or equivalent) to the cylinder block face evenly and install the ladder frame.

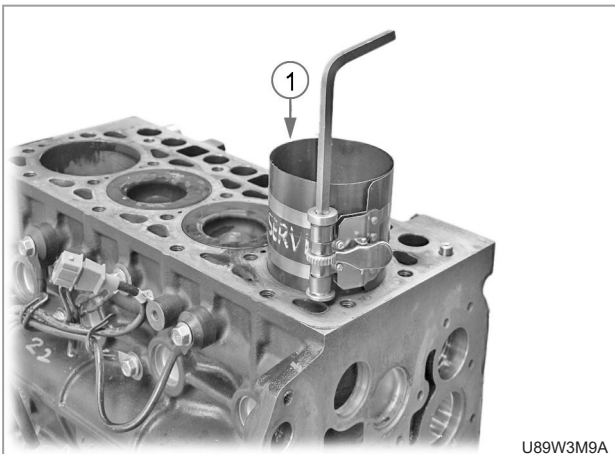

U89W3M9A

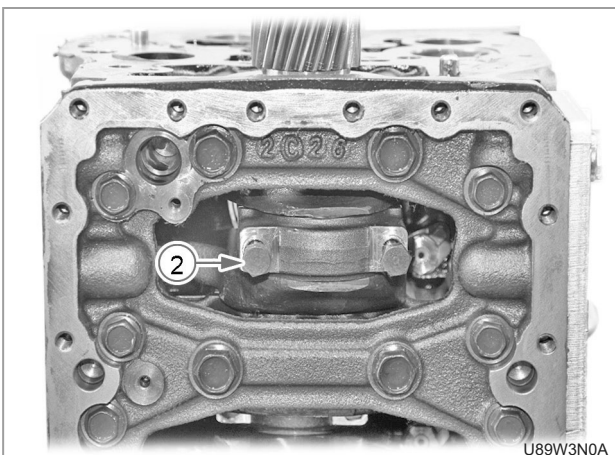

U89W3N0A

7. Insert the piston into the cylinder using a piston inserting jig (1) and tighten the connecting rod cap mounting bolts (2).

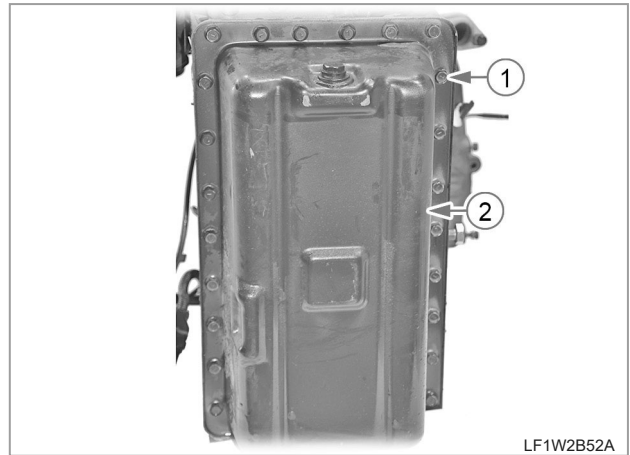

LF1W2B52A

8. Apply liquid gasket (LOCTITE #5902, #5900 or equivalent) to the mating surface of the oil pan evenly and tighten the oil pan mounting bolts (1) to install the oil pan (2) to the ladder frame.

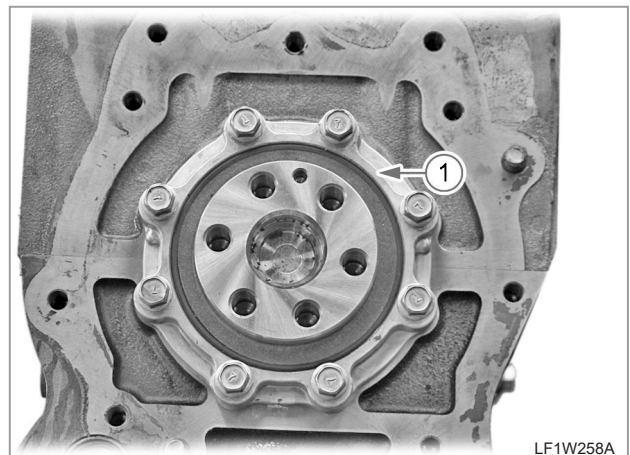

LF1W258A

9. Apply liquid gasket (LOCTITE #5902, #5900 or equivalent) to the oil seal case mating surface and install the oil seal case (1) to the cylinder block.

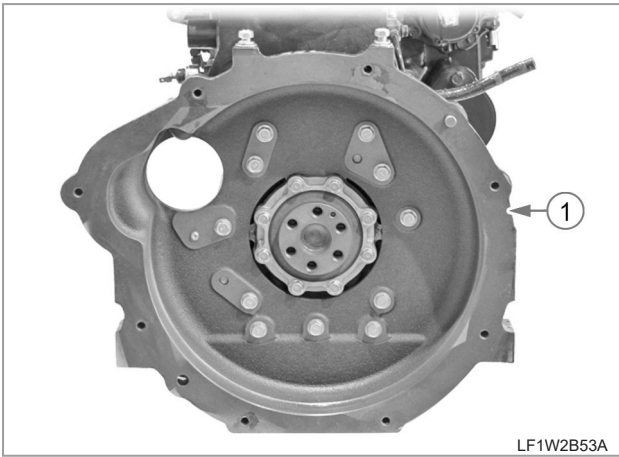

10. Apply liquid gasket (LOCTITE #5902, #5900 or equivalent) to the flywheel housing mating surface and install the flywheel housing (1) to the cylinder block.

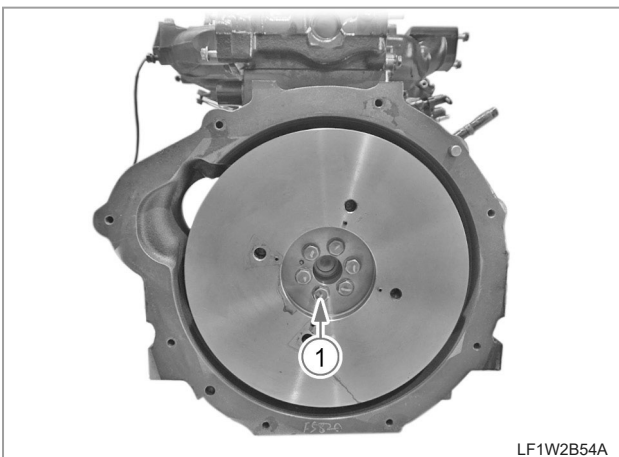

11. Install the flywheel. When installing the flywheel bolts (1), apply a small amount of oil to their threads, tighten them with a hand as far as possible and tighten them to the specified torque. Make sure to tighten the bolts diagonally in turn in several steps.

**Flywheel bolt**

**tightening torque..... 98.1 ~ 107.9 Nm**  
**10.0 ~ 11.0 kgf-m**  
**72.3 ~ 79.6 lb-ft**

**! IMPOARTANT**

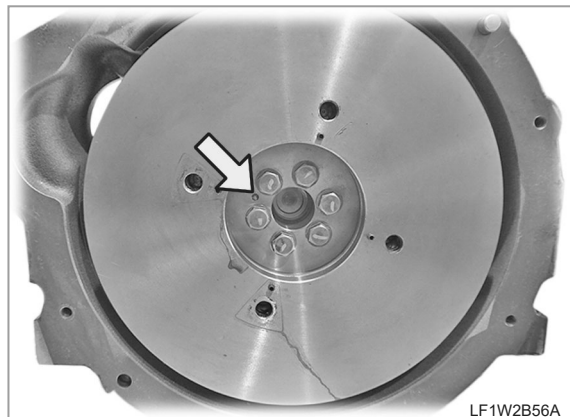
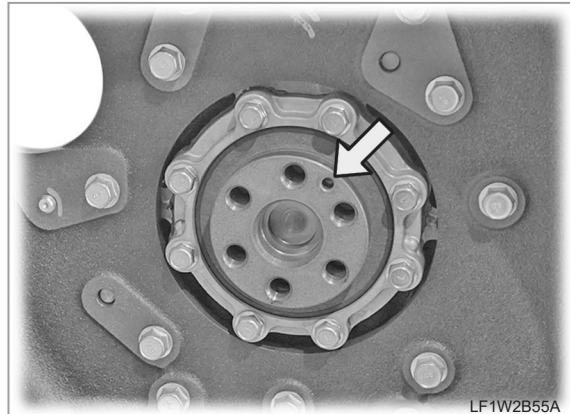

- There are installation alignment holes (A) on the mounting surfaces of the crankshaft and flywheel. Make sure to align them during installation.

**REMARKS**

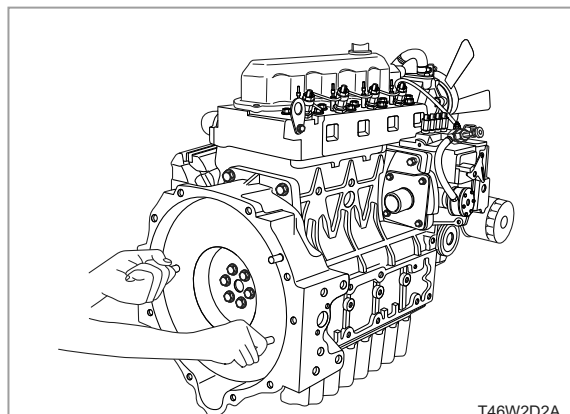

- It is recommended to insert a long bolt into the flywheel for easier installation.



### ► PISTON PIN AND BUSHING CLEARANCE

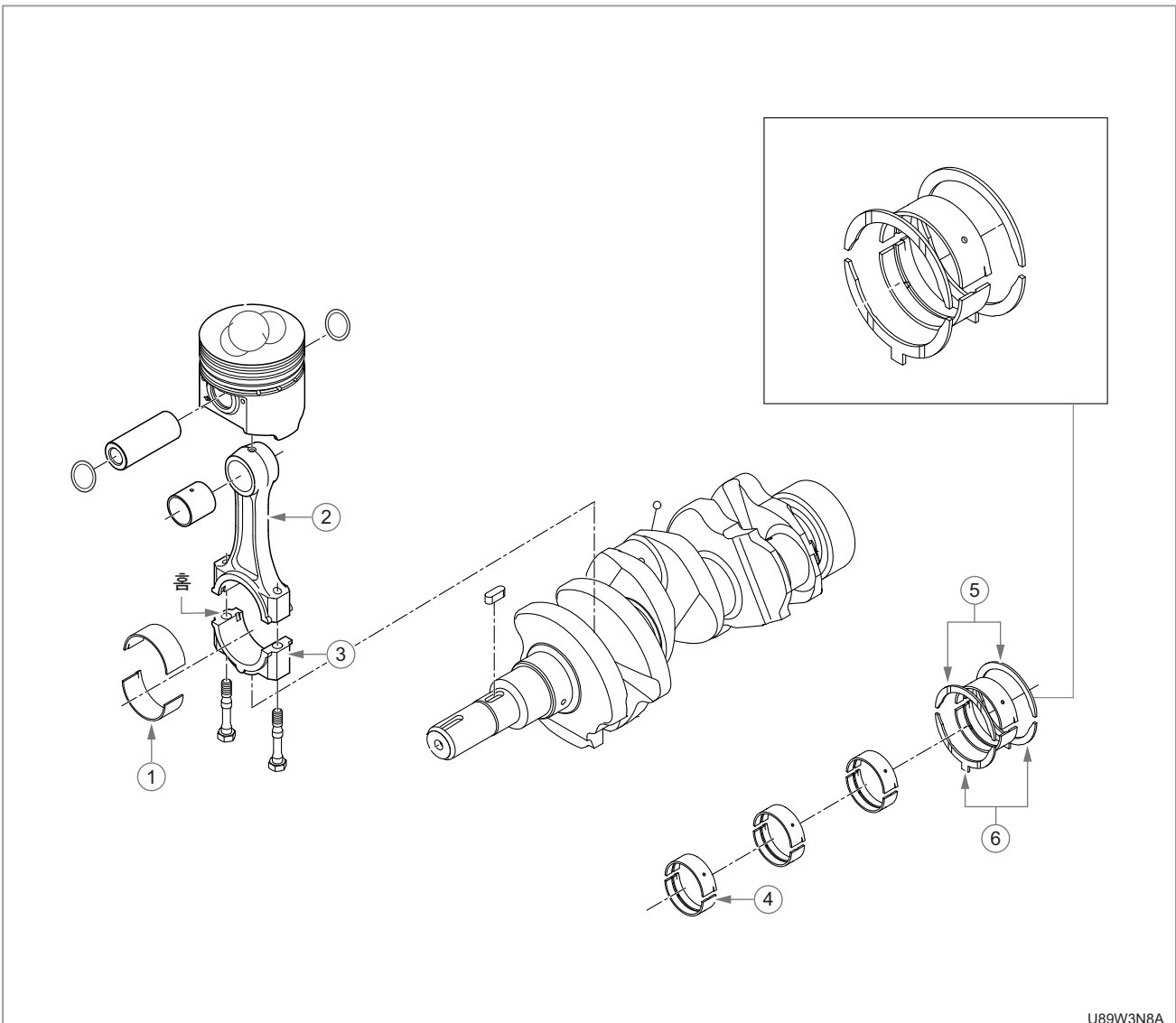

1. The connecting rod bearing (1) should be aligned with the mating notch of the connecting rod (2) or connecting rod cap (3) before installation.
  - Apply sufficient amount of oil to the bearing before and after the installation.
2. The crankshaft bearing (4) should be aligned with the notch of the cylinder block and radder frame.
  - Apply sufficient amount of oil to the bearing before and after the installation.
3. The crankshaft thrust bearing (upper) (5) and lower (6) can only be installed to the cylinder block and radder frame, which are right next to the flywheel.
  - Apply sufficient amount of oil before and after the installation.

#### ! IMPOARTANT

- The oil groove of the thrust bearing (upper), (lower) should face outward. In other words, the oil groove should be seen after the thrust bearings are installed to the cylinder block and radder frame.
- If it is installed backwards, it can cause engine stall.
- The protrusion part of the thrust bearing (lower) (6) should face downward.

**FLYWHEEL AND CRANKSHAFT CHECK**

**▶ FLYWHEEL DEFLECTION AND CRANKSHAFT END PLAY**

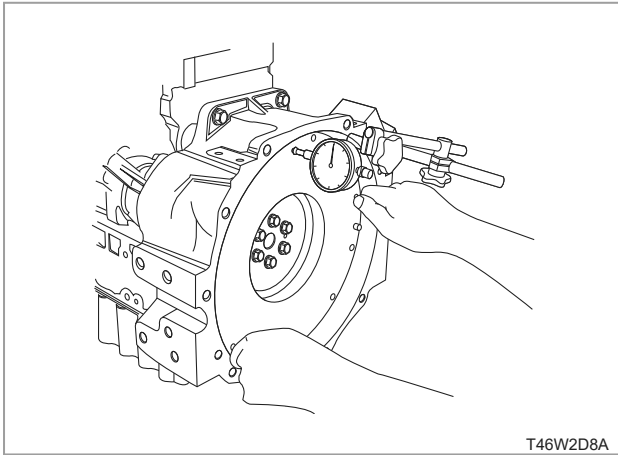

1. Set a dial indicator with its tip on the rear friction face of the flywheel near the edge.
2. Turn the flywheel to measure the deflection or the uneven wear.
3. If the measured value exceeds the allowable limit, remove the flywheel and check the mating faces of the crankshaft and flywheel.
4. If it is scored or worn excessively, regrind the surface of the flywheel or replace the flywheel.
5. Measure the end play while moving the crankshaft with flywheel back and forth to each end.
6. If the end play exceeds the allowable limit, replace the side bearing.

Deflection	Allowable limit	0.05 mm (0.0020 in.)
End play	Specified value	0.15 ~ 0.31 mm (0.0059 ~ 0.0122 in.)
	Allowable limit	0.5 mm (0.020 in.)

**▶ CRANKSHAFT DEFLECTION**

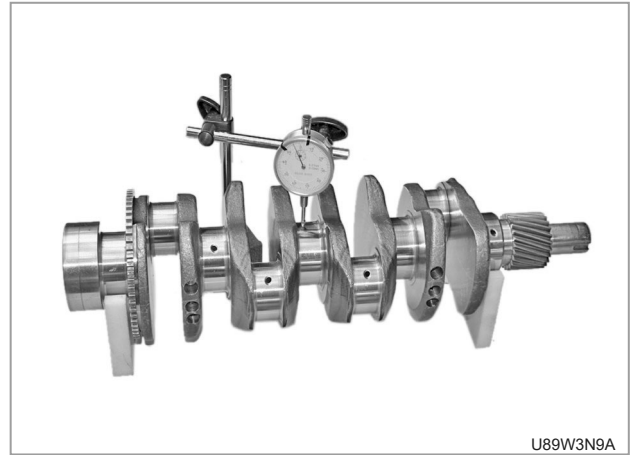

1. Place the crankshaft on V blocks with its journals supported and set a dial indicator with its tip on the intermediate journal.
2. Measure the eccentricity (half of the measured value) while turning the crankshaft on the V blocks.
3. If the eccentricity exceeds the allowable limit, replace the crankshaft.

Eccentricity	Allowable limit	0.08 mm (0.0031 in.)
--------------	-----------------	-------------------------

► **CRANKSHAFT JOURNAL AND BEARING 1 OIL CLEARANCE**

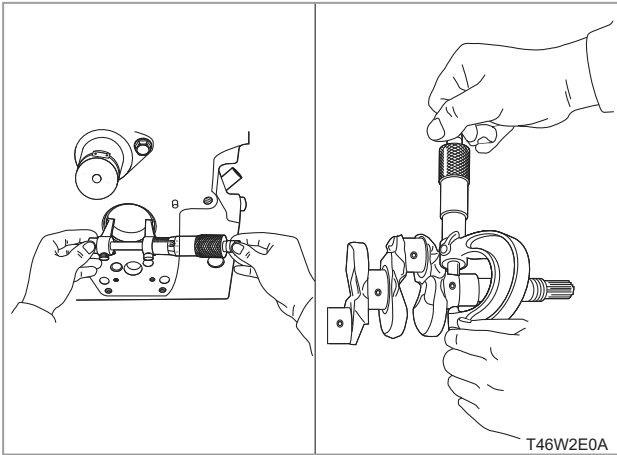

1. Measure the I.D. of the crankshaft bearing 1 with an inside micrometer.
2. Measure the O.D. of the crankshaft journal with an outside micrometer.
3. If the clearance exceeds the allowable limit, replace the crankshaft metal bearing.

Oil clearance	Specified value	0.040 ~ 0.104 mm (0.00153 ~ 0.00400 in.)
	Allowable limit	0.20 mm (0.0079 in.)
Journal O.D.	Specified value	59.921 ~ 59.940 mm (2.35909 ~ 2.35984 in.)
Bearing 1 I.D.	Specified value	59.980 ~ 60.025 mm (2.36142 ~ 2.36319 in.)

► **CRANK PIN AND CONNECTING ROD BEARING OIL CLEARANCE**

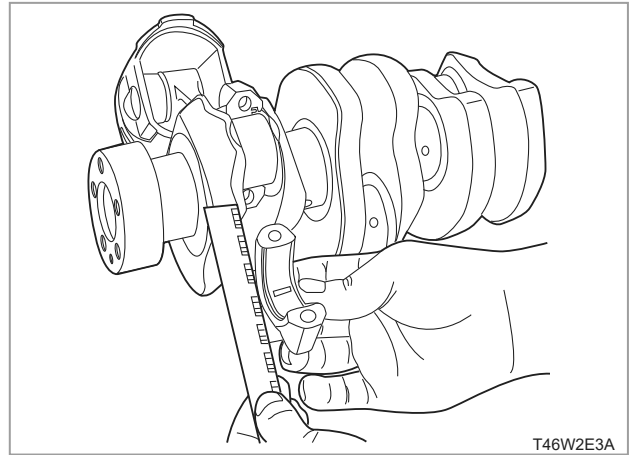

1. Place a plastigauge in lengthwise on the center of the crankpin.
2. Install the connecting rod, tighten the bolts to the specified torque once and remove the cap again.
3. Measure the amount of the flatness with the scale and get the oil clearance.
4. If the clearance exceeds the allowable limit, replace the bearing.

Oil clearance	Specified value	0.017 ~ 0.073 mm (0.00067 ~ 0.00287 in.)
	Allowable limit	0.20 mm (0.0079 in.)
Crankshaft pin O.D.	Specified value	51.959 ~ 51.975 mm (2.04563 ~ 2.04626 in.)
Crankshaft pin Bearing I.D.	Specified value	51.992 ~ 52.032 mm (2.04693 ~ 2.04850 in.)

► **CYLINDER BORE CHECK**

1. Check the worn condition of the honing groove on the bore.

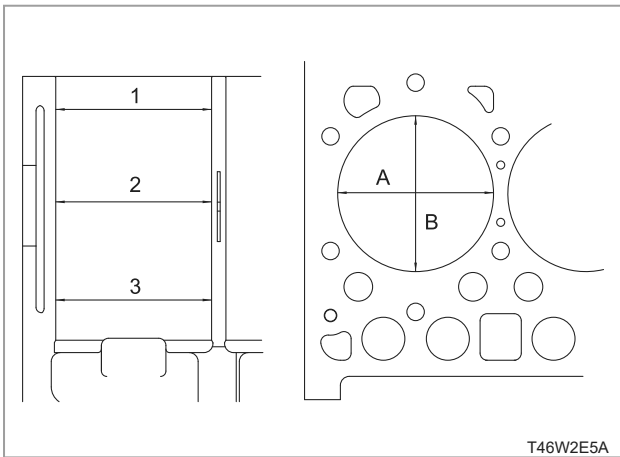
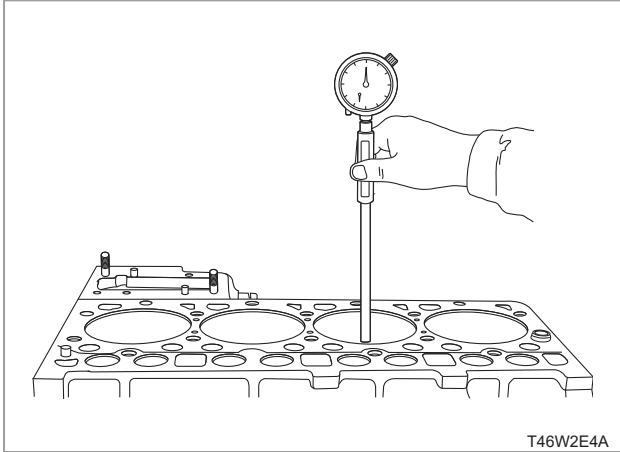

(A) Axial direction (1,2,3) Measuring Points  
(B) Transverse direction

2. Check the bore for scuffing or scoring.
3. Measure the cylinder liner I.D. at six locations as shown in the figure to find the largest worn area.

Cylinder liner I.D. Specified value	87.000 ~ 87.022 mm (3.425 ~ 3.4261 in.)
--	--

**7.4.11 OIL FILTER**

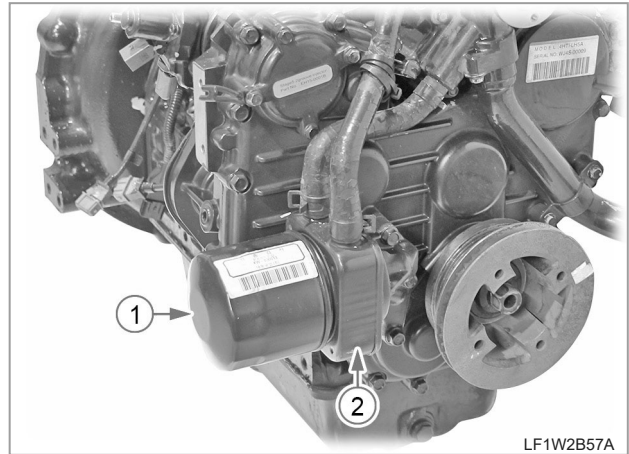

(1) Oil filter (2) Oil cooler

1. Drain engine oil and remove the engine oil filter (1) and engine oil cooler (2) for inspection.

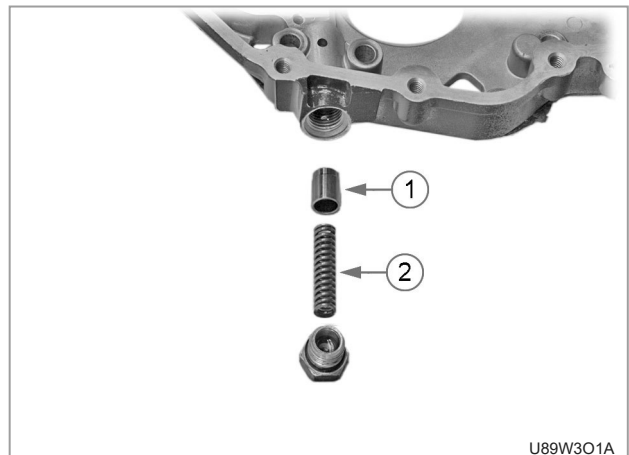

2. Remove the relief valve from the side of the gear case and check the plunger (1) and spring (2) for deformation. If damaged, replace it with a new one.
3. Measure the free length of the spring. If the measurement is over the allowable limit, replace it with a new one

Spring Free length	Specified value	43.8 mm (1.7244 in.)
	Allowable limit	39.0 mm (1.5354 in.)

 REMARKS

**OIL FILTER FLOW AND OIL COOLER COOLANT FLOW**

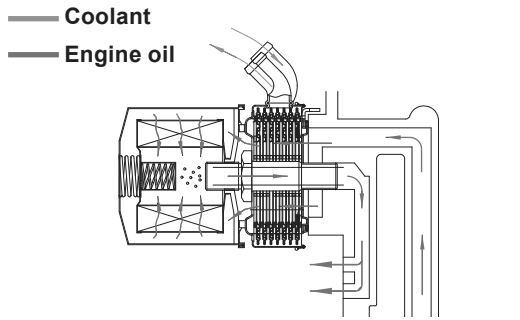

U89W3O2A

7.4.12 OIL PUMP

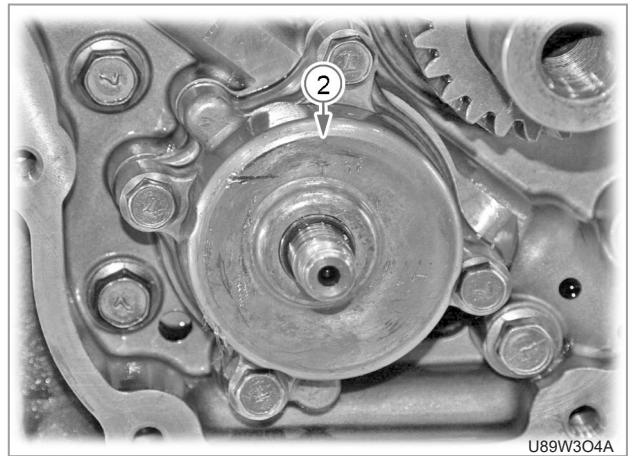
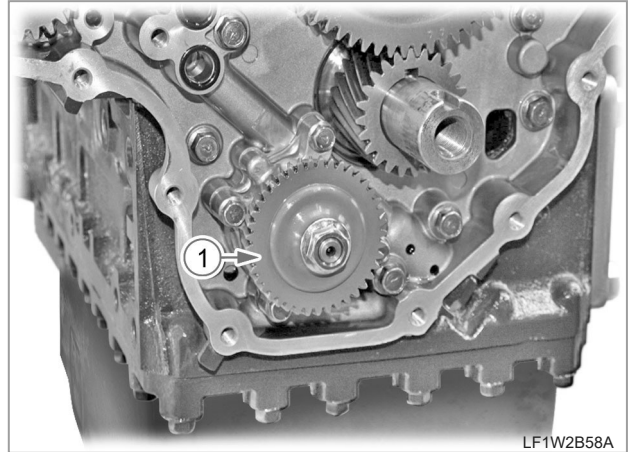

(1) Oil pump gear

(2) Oil pump ass'y

1. Remove the oil pump gear (1) from the lower section of the gear case. Then, remove the oil pump assembly (2).

SAFETY FIRST

ENGINE

DRIVING & CHASSIS

HYDRAULIC SYSTEM

ELECTRIC SYSTEM

CABIN

INDEX

**OIL PUMP CHECK**

► **CLEARANCE BETWEEN ROTOR AND LOBE CLEARANCE OF OIL PUMP**

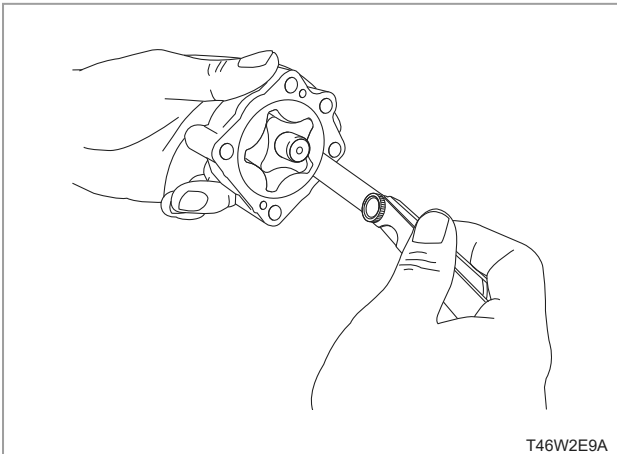
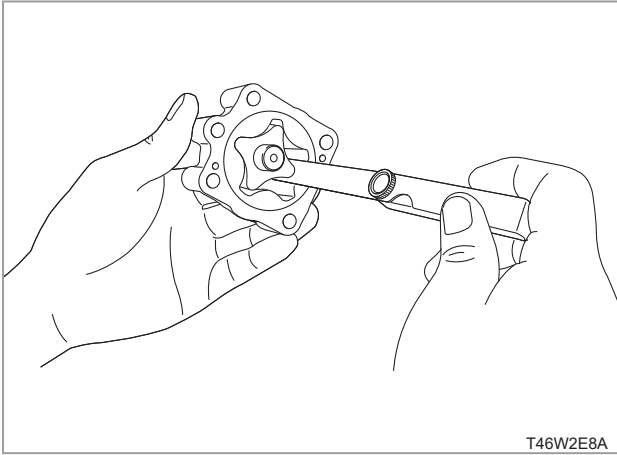

1. Measure the clearance between the outer rotor and inner rotor with a feeler gauge.
2. Measure the clearance between the outer rotor and the housing with a feeler gauge.
3. If the clearance exceeds the allowable limit, replace the pump.

Clearance between outer rotor and inner rotor	Specified value	0.10 ~ 0.16 mm (0.0039 ~ 0.0063 in.)
	Allowable limit	0.20 mm (0.0079 in.)
Clearance between outer rotor and housing	Specified value	0.11 ~ 0.19 mm (0.0043 ~ 0.0075 in.)
	Allowable limit	0.25 mm (0.0098 in.)

► **END CLEARANCE OF ROTOR IN OIL PUMP**

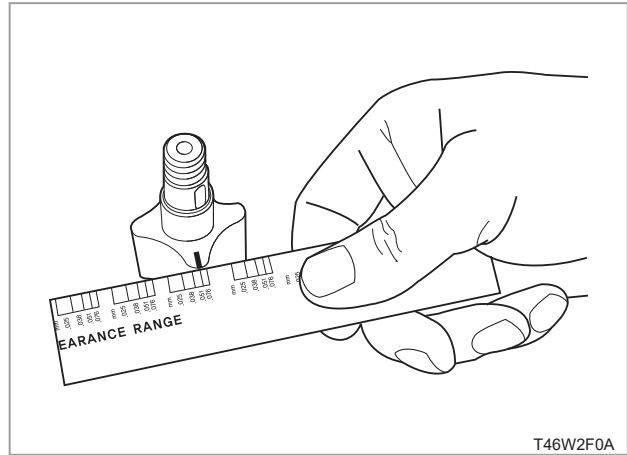

1. Place a plastigauge on the rotor and assemble the pump.
2. Disassemble the pump and measure the amount of the flatness with a scale to get the clearance.
3. If the clearance exceeds the allowable limit, replace the pump.

End clearance	Specified value	0.105 ~ 0.150 mm (0.00423 ~ 0.00591 in.)
	Allowable limit	0.20 mm (0.0079 in.)

7.4.13 THERMOSTAT

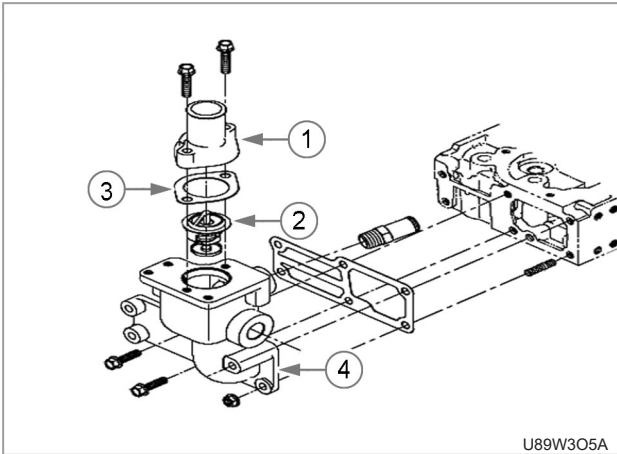

- (1) Thermostat cover
- (2) Thermostat
- (3) Thermostat cover gasket
- (4) Coolant flange

REMOVAL

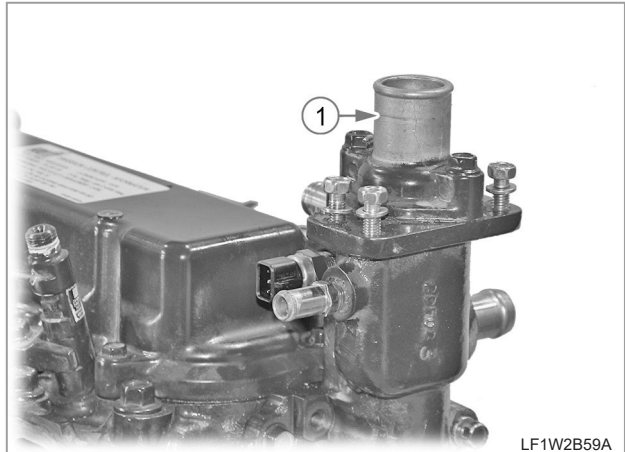

1. Remove the thermostat cover (1).

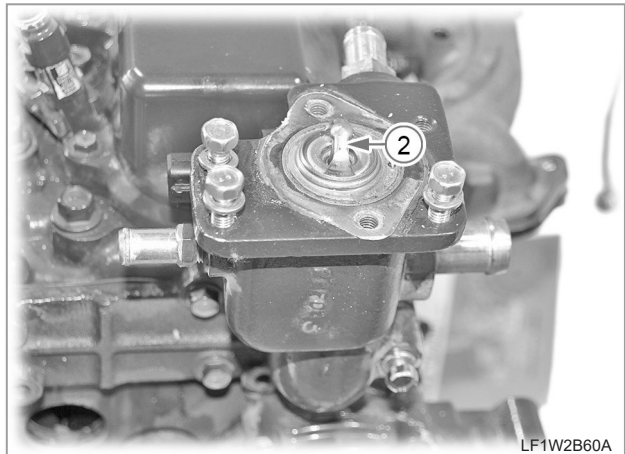

2. Pull out the thermostat (2).

**INSTALLATION**

- Apply liquid gasket (Three Bond 1215 or equivalent) to the gasket.

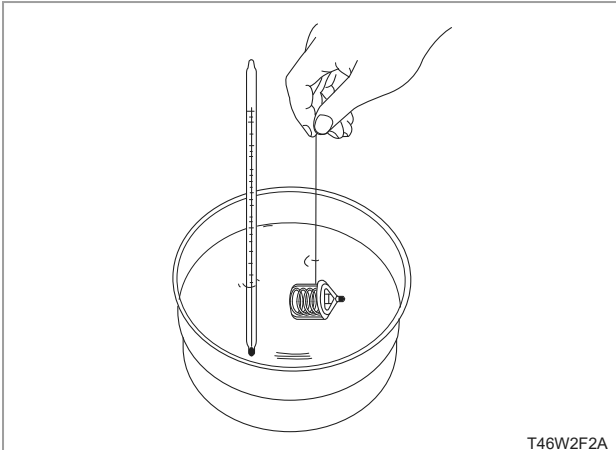
**OPENING TEMPERATURE OF THERMOSTAT VALVE**

- Suspend the thermostat in the water by a string with its end inserted between valve and seat.
- While heating the water slowly, read the temperatures when the valve starts to open and when the valve opens for approx. 8 mm.
- If the measured values are not within the specified value, replace the thermostat.

Opening temperature	Specified value	Initial opening temperature:
		Below 95 °C (203 °F) at opening by 8 mm (0.315 in.)

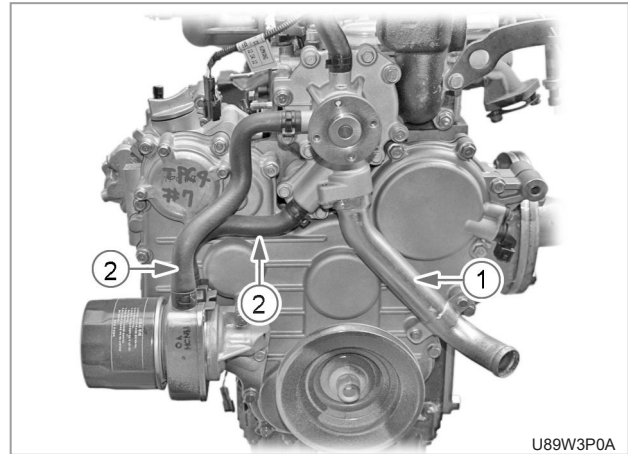
**7.4.14 WATER PUMP**

- Disconnect the water pump pipe (1) and oil cooler hoses (2) on the face of the gear case from the water pump side.

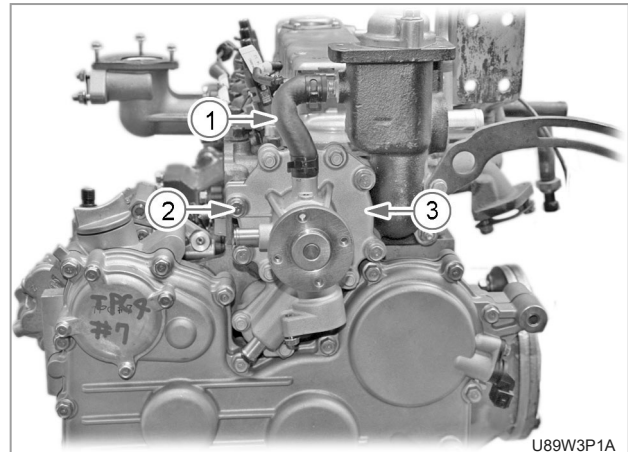

- Disconnect the coolant return hose (1) and unscrew the water pump case mounting bolts (2) to remove the water pump case assembly (3).



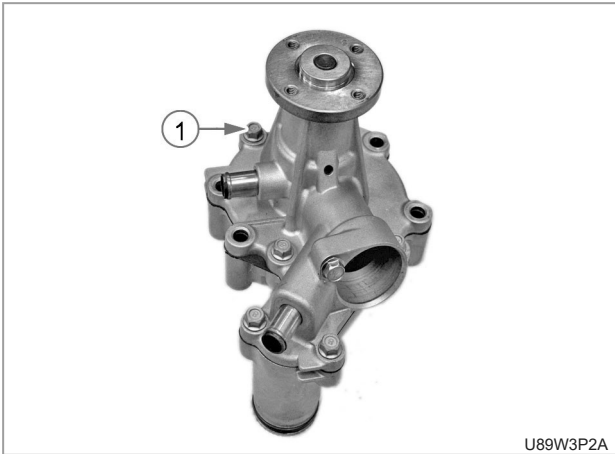

U89W3P2A

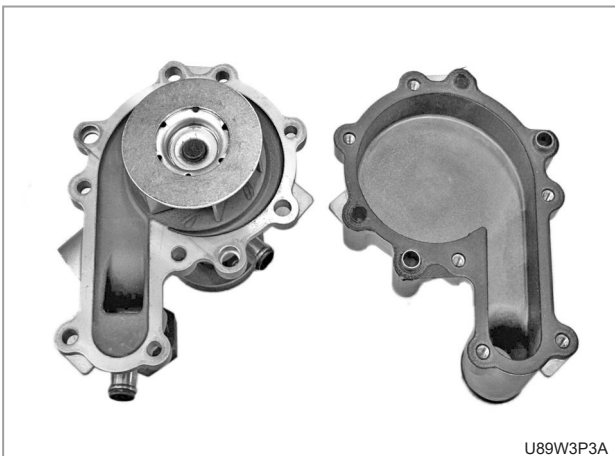

U89W3P3A

3. Unscrew the main case mounting bolts (1) from the removed water pump assembly to separate the case and cover.

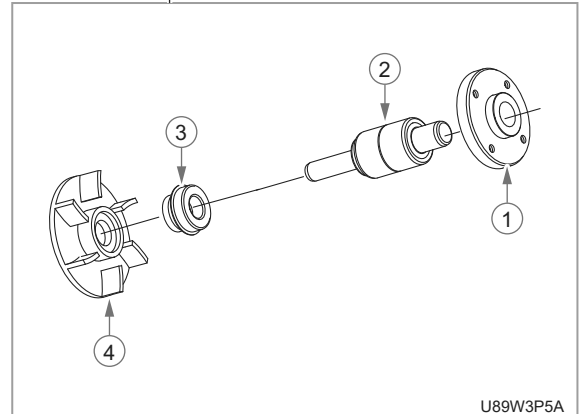
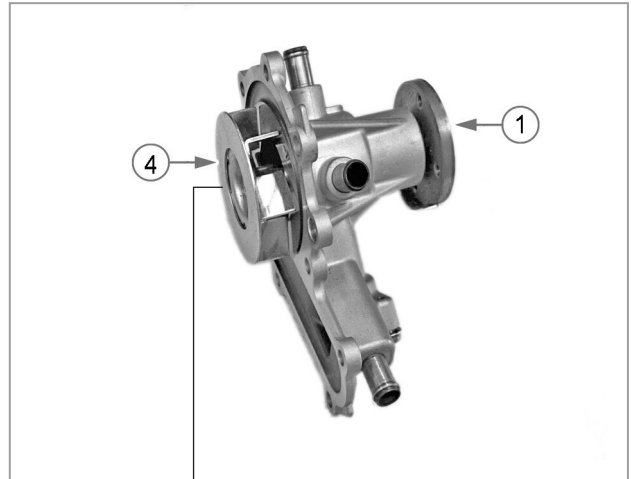

U89W3P5A

U89W3P4A

- (1) Water pump flange
- (2) Water pump shaft bearing
- (3) Mechanical seal
- (4) Impeller

4. Remove the water pump flange (1) from the main case.
5. Remove the impeller (4) and mechanical seal (3) from the water pump shaft bearing (2).
6. If the mechanical seal is to be removed, replace it with a new one.

**CAUTION**

- The components of the water pump is firmly assembled together and they cannot be easily disassembled or assembled without a special equipment. Therefore, it is recommended to replace the whole water pump assembly.

## 7.4.15 FUEL FILTER

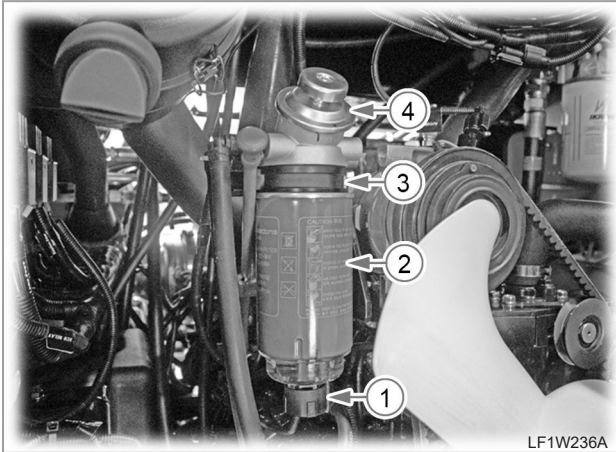

LF1W236A

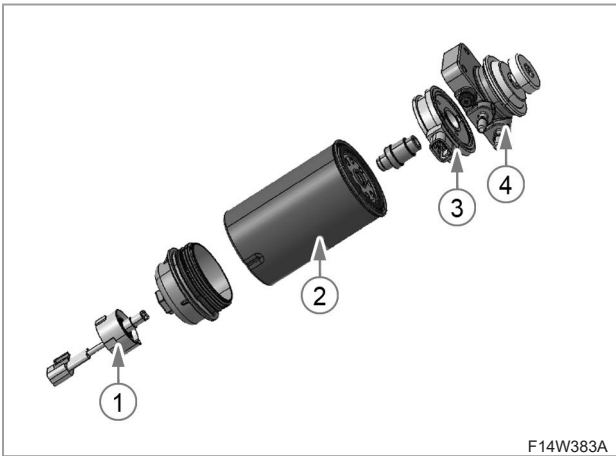

F14W383A

1. Rotate the water-in-fuel sensor (1) and filter body (2) to remove them from the removed fuel filter assembly. Then, remove the fuel heater (3) and priming pump (4).

## REMARKS



U89W3P8A

- When installing a new filter body for replacement, apply a thin film of oil onto the O-ring surface (A) and tighten the filter firmly with a hand.

## 7.4.16 TURBO CHARGER

## WARNING

- As the turbocharger operates at a high speed and high temperature, there should be no tool or foreign materials around its inlet and outlet. Especially, be careful not to touch them with a finger or body.

1. Lift up the cabin to open the engine compartment. (Refer to the instructions for engine removal in Chapter 2.)



LF1W237A

2. Open the rear cover and disconnect the negative (-) battery cable.

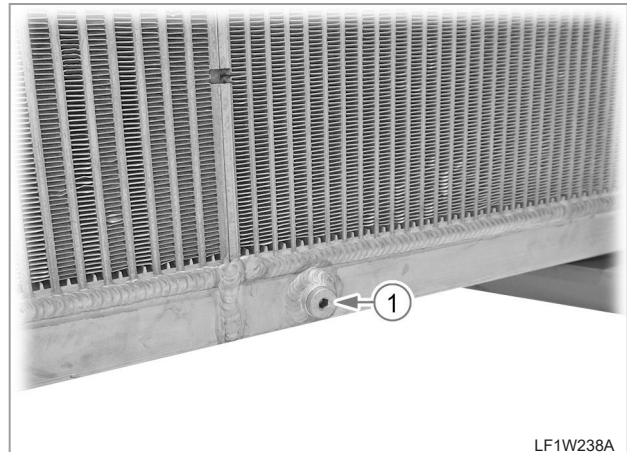

LF1W238A

3. Unscrew the radiator drain plug (1) to drain the coolant.

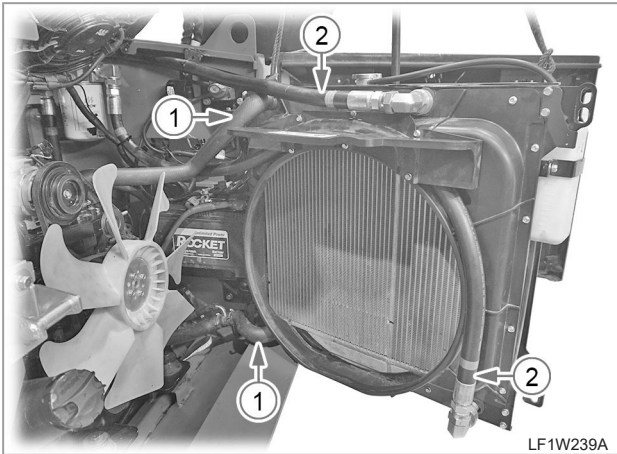

4. After opening the radiator, disconnect the radiator cooling hose (1) and oil cooler connecting hose (2).

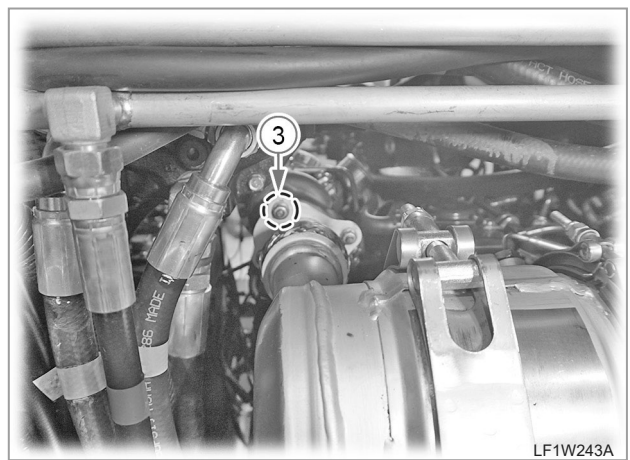
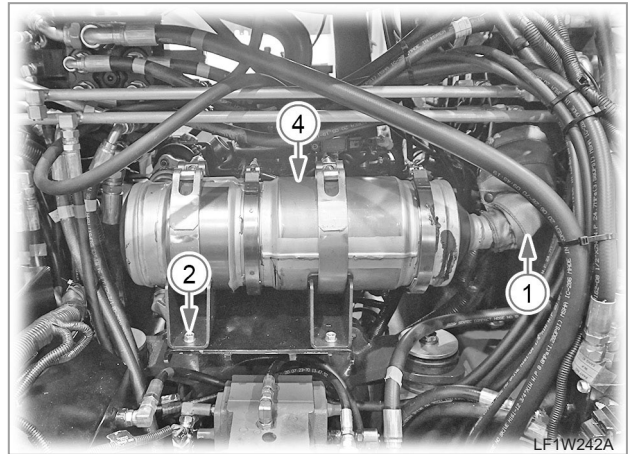

7. After disconnecting the CCRT wiring connector and connecting rod (1), unscrew the CCRT mounting bolts (2) and nuts (3) to remove the CCRT assembly (4).

**Mounting bolt & nut  
tightening torque..... 44.0 Nm  
4.5 kgf-m  
32.0 lb-ft**

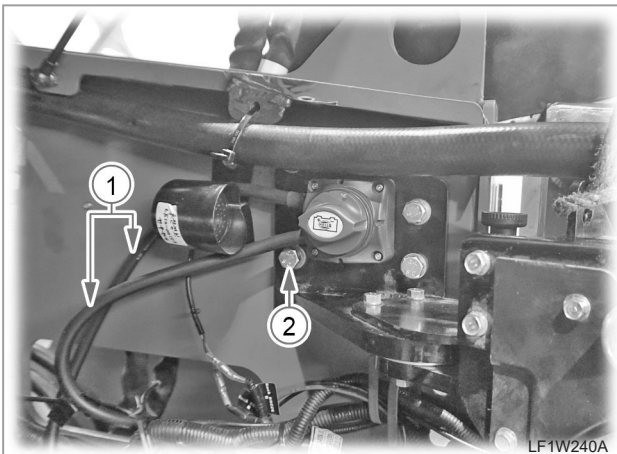

5. Hang the radiator assembly on a hoist. Disconnect the power cut-off switch wiring (1) from the radiator support bracket side, unscrew the bracket mounting bolts (2) and lift up the radiator assembly to remove it.

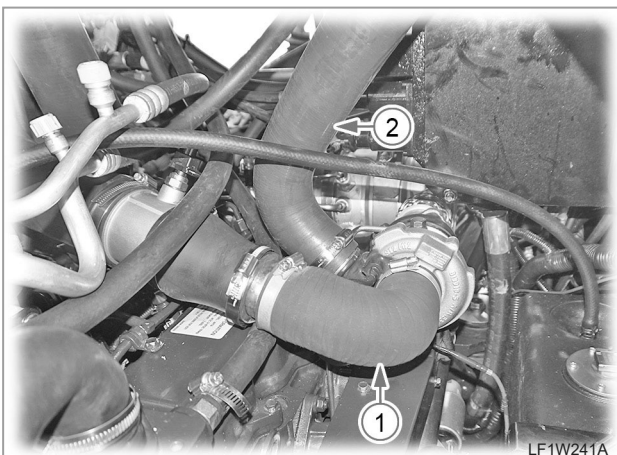

6. Disconnect the air cleaner suction hose (1), intercooler connecting hose (2) and blowby hose from the turbocharger.

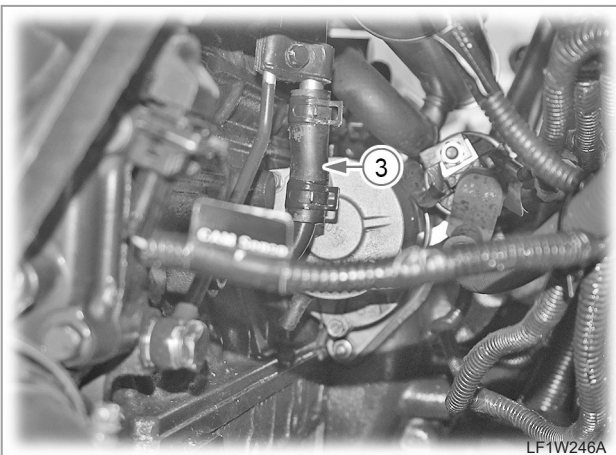
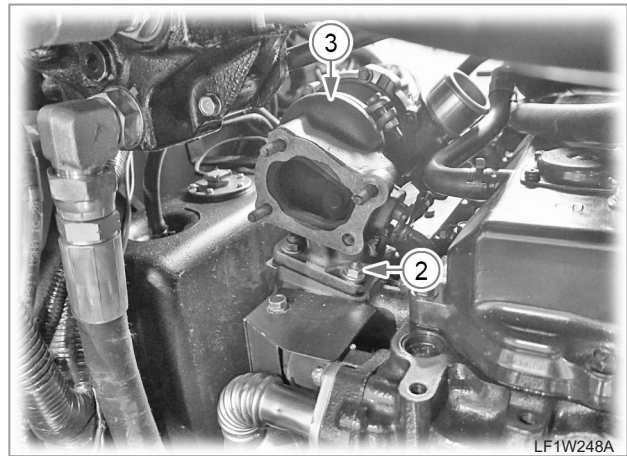
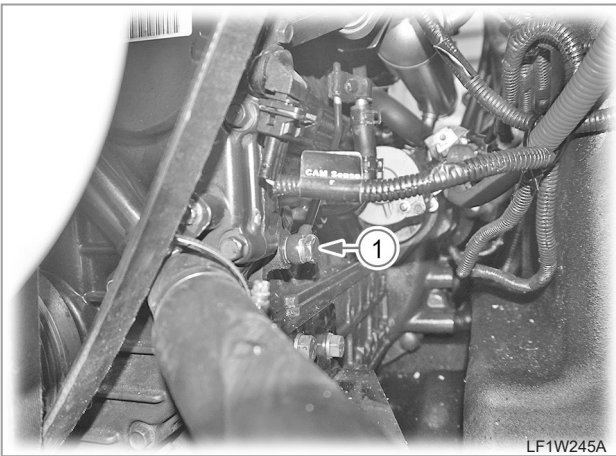
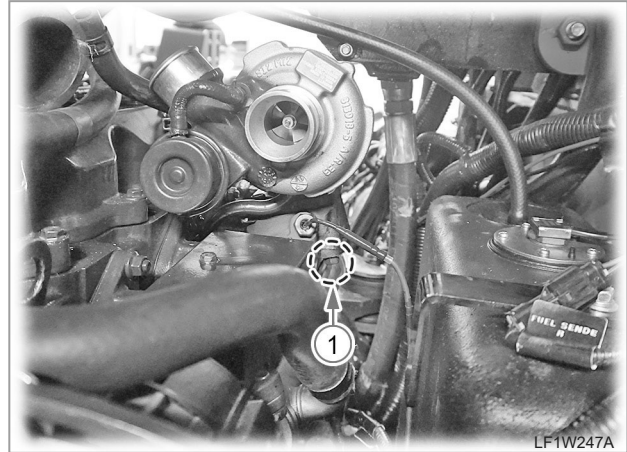
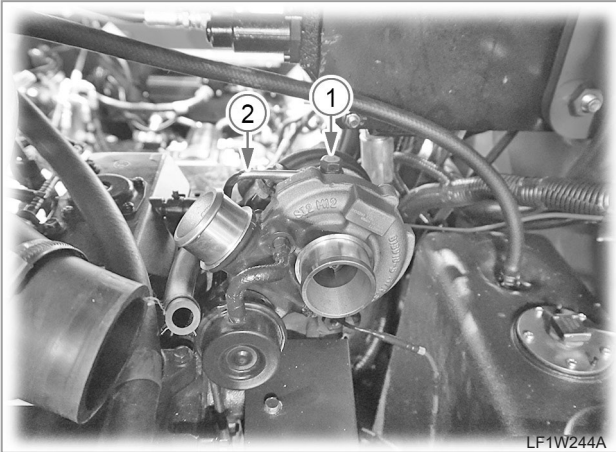

8. Loosen the oil feed pipe mounting bolt (1) to disconnect the oil feed pipe (2). Then, disconnect the return pipe connecting hose (3).

9. Loosen the turbocharger mounting bolts (1) and nuts (2) to remove the turbocharger assembly (3).

**Turbocharger mounting bolt**  
 tightening torque..... 47.0 Nm  
 4.8 kgf-m  
 34.0 lb-ft

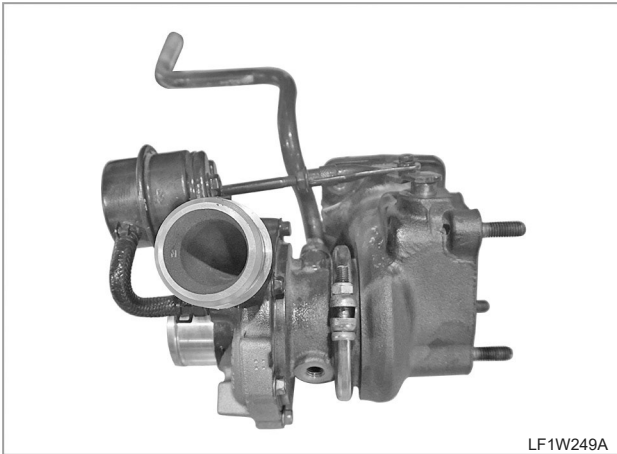

LF1W249A

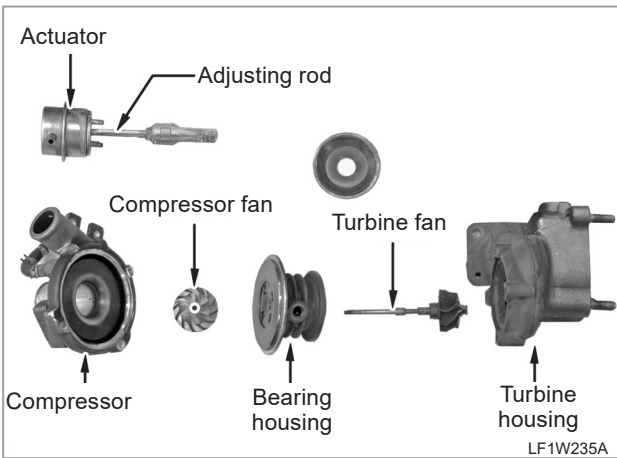

LF1W235A

10. If necessary, remove the turbocharger assembly.

REMARKS

**TURBOCHARGER COMPONENT TIGHTENING TORQUE**

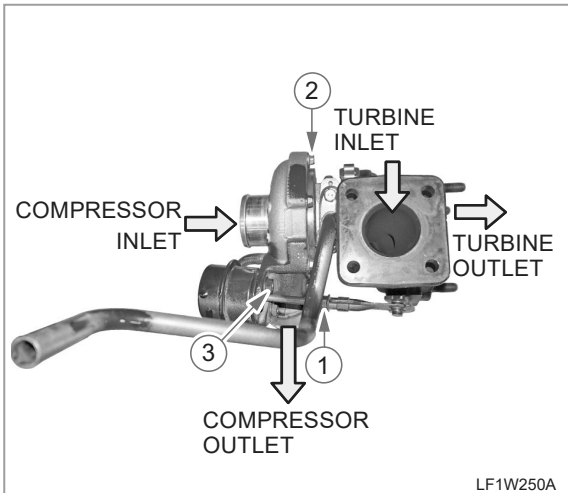

LF1W250A

- ① 2.3 ~ 4.5 Nm
- ② 6.0 ~ 8.0 Nm
- ③ 5.6 ~ 6.8 Nm

8. DIAGNOSIS

8.1 DIAGNOSTIC PROGRAM

UVIM COMMUNICATION MODULE PARTS



UVIM COMMUNICATION MODULE CONNECTING METHOD

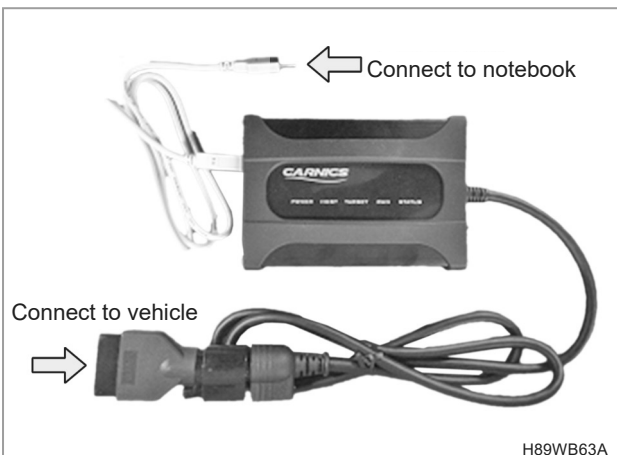

SAFETY FIRST

ENGINE

DRIVING & CHASSIS

HYDRAULIC SYSTEM

ELECTRIC SYSTEM

CABIN

INDEX

**INSTALL PROGRAM**

▶ **INSTALL MICROSOFT VISUAL C++ 2008 SP1 REDISTRIBUTABLE PACKAGE**

1. Copy vcredist\_x64\_eng.exe and vcredist\_x86\_eng.exe on laptop's wallpaper.
2. If you use 32bit's OS, Install vcredist\_x86\_eng.exe.
3. If you use 64bit's OS, Install vcredist\_x64\_eng.exe.
4. If you don't know OS type, Install vcredist\_x86\_eng.exe. If it doesn't install, Install vcredist\_x64\_eng.exe

▶ **INSTALL FT4 DIAGNOSTIC PROGRAM**

1. Copy Installation Program on laptop's wallpaper.
2. Run Installation Program.
3. Install Program.
4. Installation completed.
5. Icon will be shown on wallpaper.

**UVIM USB DRIVER RECOGNITION**

▶ **WINDOWS 7 - AUTOMATICALLY INSTALLED**

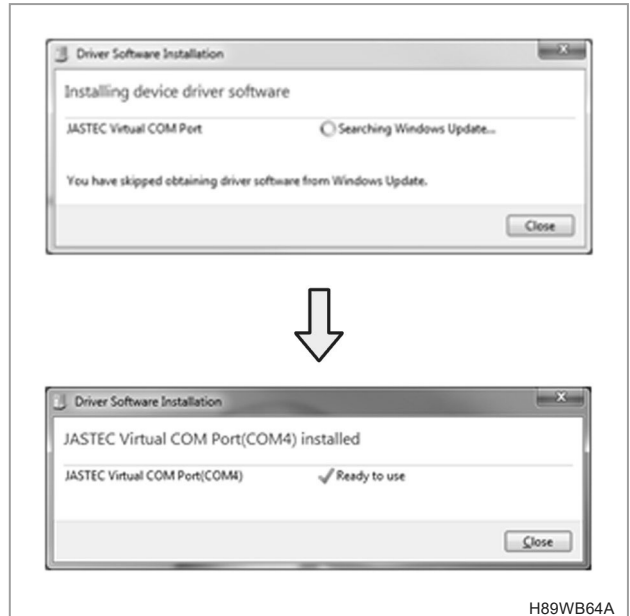

► WINDOWS XP

1. After installing the program, please progress as follows.
2. Connect deskuVIM to laptop by USB cable.
3. Progress as follows.

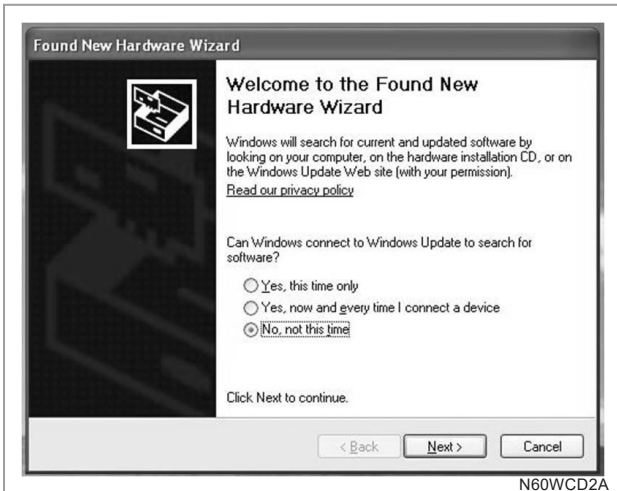

N60WCD2A



N60WCD3A

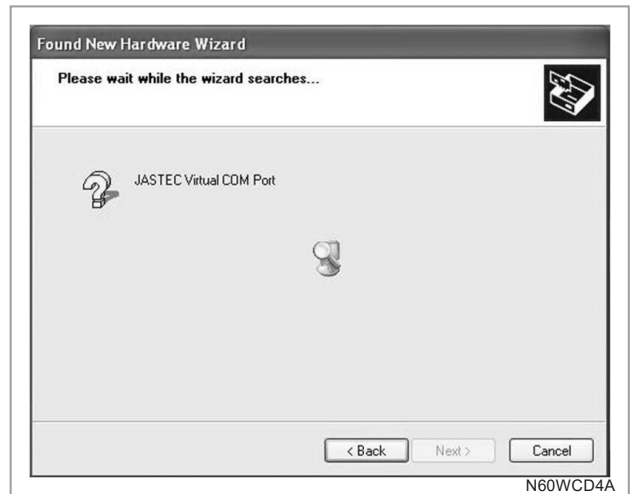

N60WCD4A

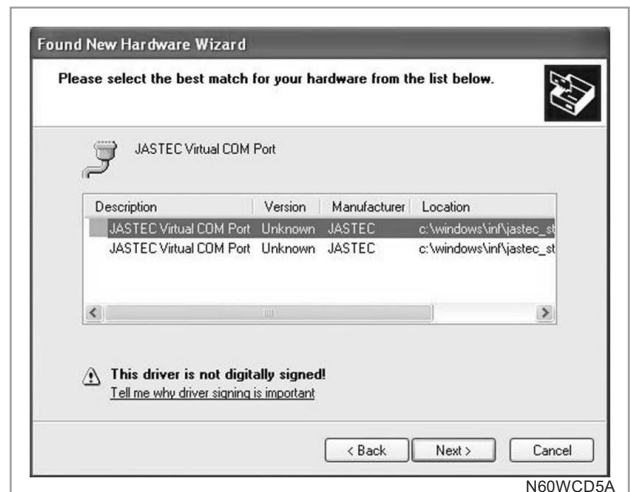

N60WCD5A



**USER AUTHENTICATION AND LOGIN**

**► AUTHENTICATION**

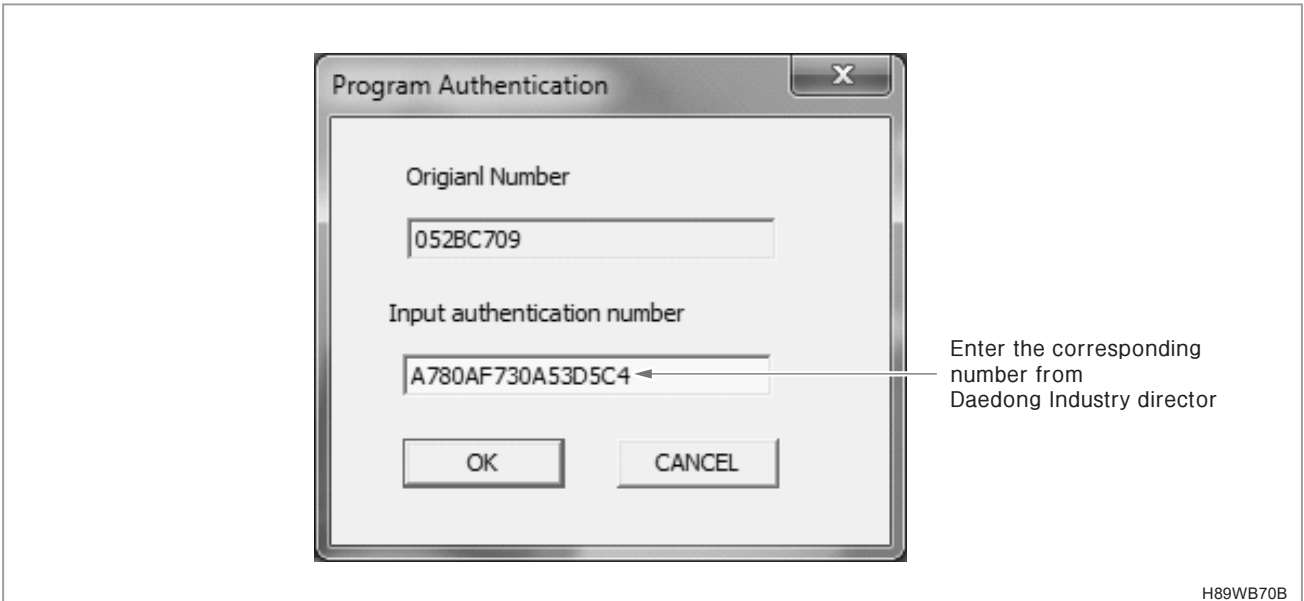

H89WB70B

1. When you run the program, registration screen will be shown.
2. Original Number of installed laptop will be shown.
3. Transfer Original Number to HYUNDAI Industry administrator. Receive applicable Key value and enter applicable Key value.
4. Click OK button.

**► LOGIN**

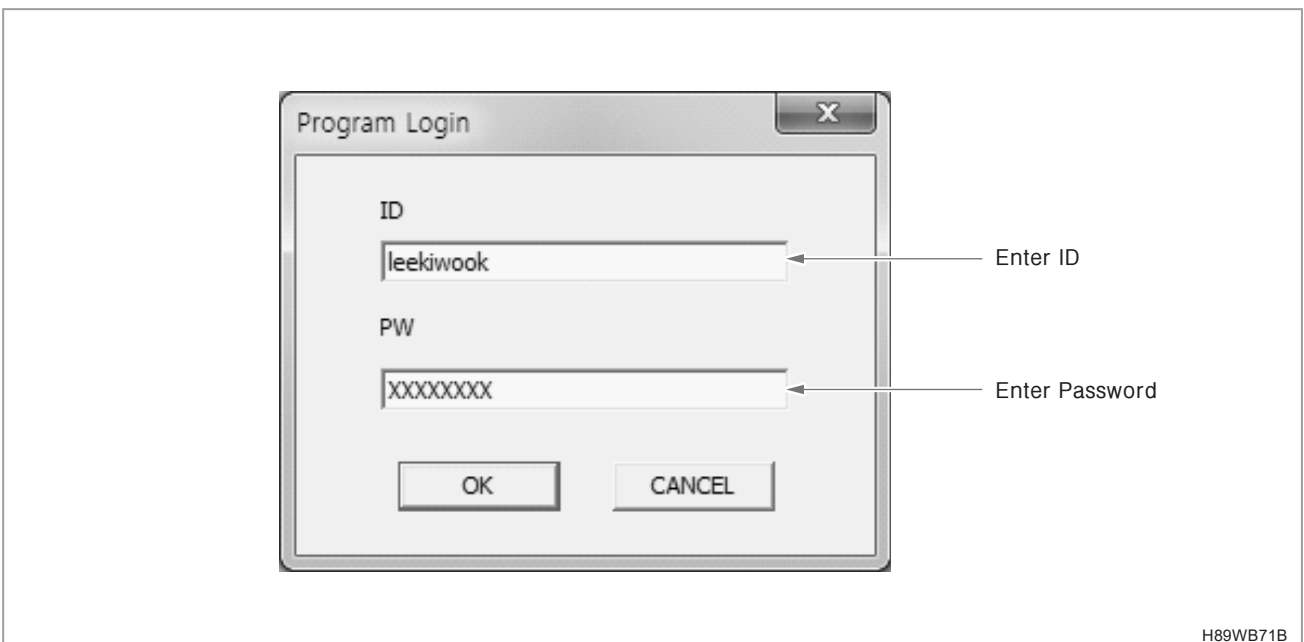

H89WB71B

1. If it has been normally registered, Login screen will be shown.
2. Enter ID and PW that received from administrator.
3. Click OK button.

## PROGRAM MANUAL

## ▶ UPPER MENU



H89WB72B

- MENU(M)
  - Exit : Exit the program.
- SETTING(S): Set the setting value for program.

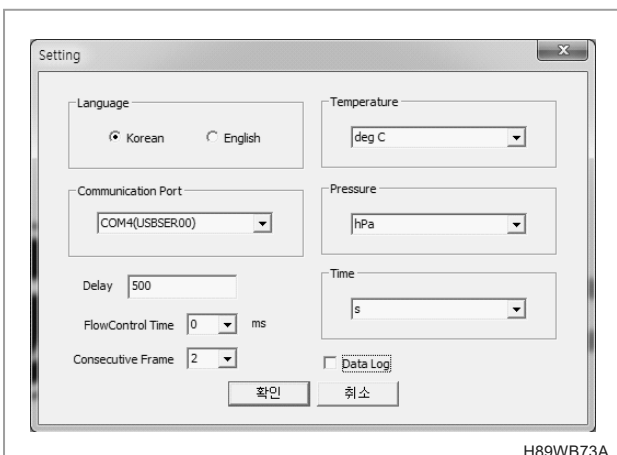

H89WB73A

- Language : Korean/English choice
- Communication Port : uVIM USB Port
- Delay : Enter as 500. If reprogram time is over 5 minutes, enter as 0.
- FlowControl Time : Set as 0
- Consecutive Frame : Set as 2
- Temperature : Kelvin, °C, °F
- Pressure : bar, hPa
- Time : s(second), hour

- VIEW(V)
  - Application Shape : Change program screen as various types.

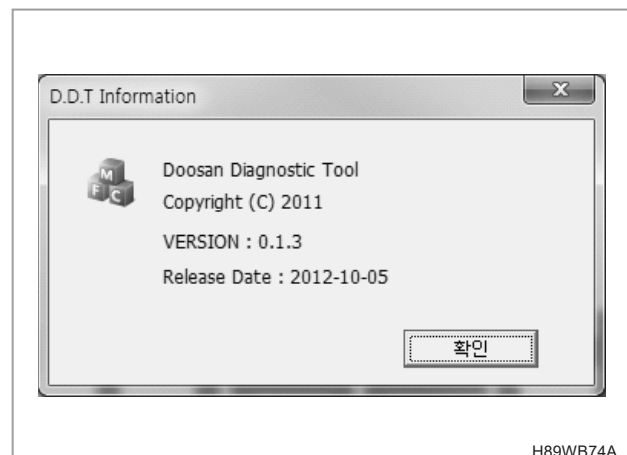

H89WB74A

- HELP(H)
  - FT4Scan Information : Program version and Release Date will be shown.
  - Fault code : fault code list will be shown on screen.
  - Manual : Help will be shown on screen.

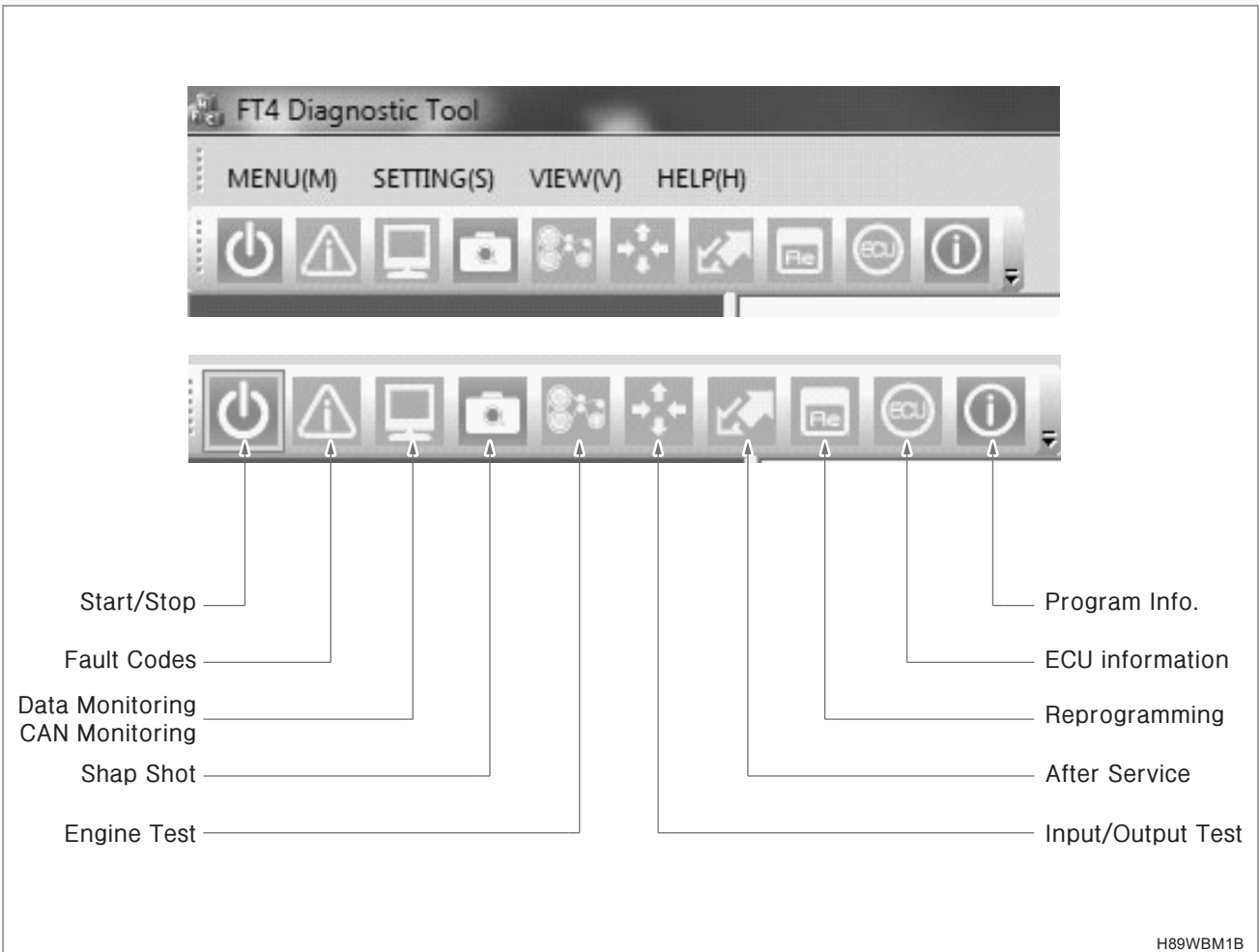

H89WBM1B

- If you click icon, run that function. If you move mouse's point to icon, display icon's short name.

▶ MAIN MENU

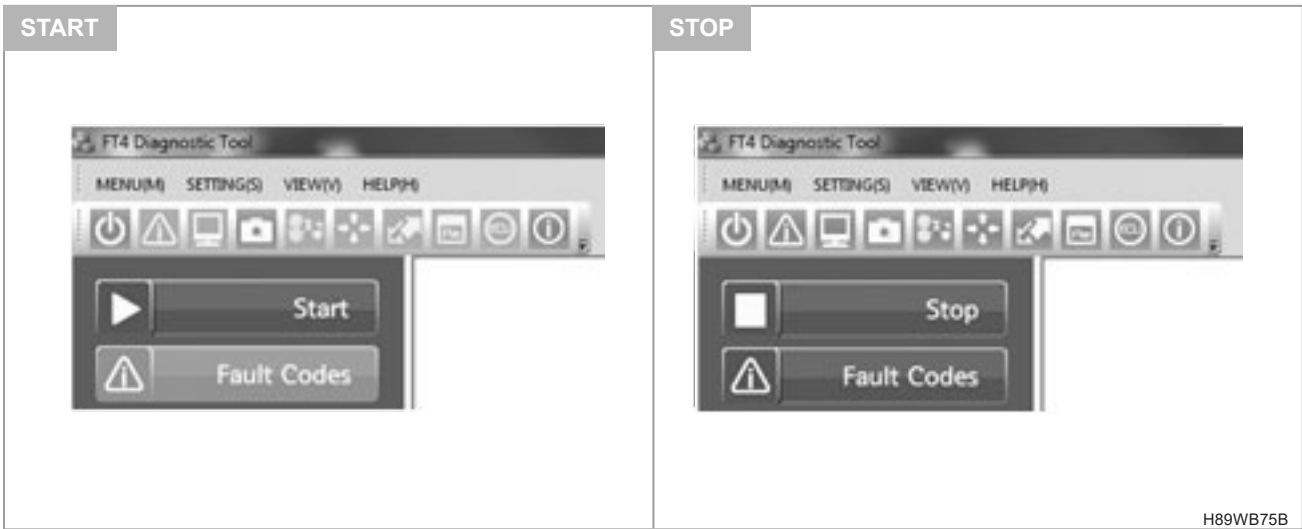

H89WB75B

- Start Button: Starting communication between FT4Scan Program and Vehicle ECU.
- Stop Button: Closing communication between FT4Scan Program and vehicle ECU.

FAULT CODES

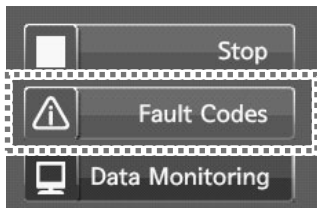

Fault code	Description	Activity	Freeze Frame
01 P0001-13	IMV driver signal open circuit (OC) fault is detected	Present	Description
02 P0204-13	ACV FEEDBACK POSITION NOISE FAULT	Present	Description
03 P0203-13	ACV FEEDBACK POSITION & LEARNING FAULT	Present	Description
04 P0201-13	ACV FEEDBACK POSITION & LEARNING FAULT	Present	Description
05 P0202-13	ACV CURRENT FAULT	Present	Description
06 P0487-24	Throttle position feedback signal high fault	Present	Description
07 P2100-13	Throttle H-Bridge driver in ECU fault: OC	Present	Description
08 P1667-13	INJECTOR DRIVER CIRCUIT PERFORMANCE BANK 'A' FAULT	Present	Description
09 P1663-13	CYLINDER BALANCING FAULT (INJ 2): MISFIRE	Present	Description
10 P0685-00	DPF REGENERATION WARNING LAMP FAULT	Present	Description

H89WB76B

- Click the Fault Codes button and failure information will be shown.
  - (1) Erasing Fault Codes.
  - (2) Save Fault Codes as Excel file.
  - (3) Indicating current Fault Codes.
  - (4) Indicating Fault Codes number.
  - (5) Indicating description of Fault.
  - (6) Indicating Current DTC/History DTC.
  - (7) Checking detailed description of applicable fault

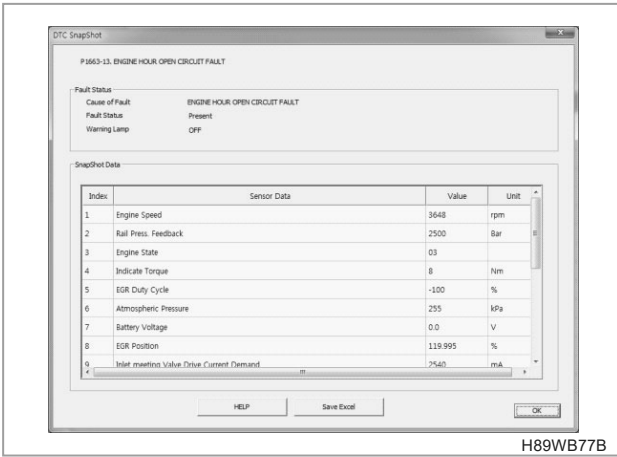

H89WB77B

- Click Description(7) button, checking detailed description of applicable fault is available.

**REMARK**

**FAULT CODE INFORMATION - DETAIL**

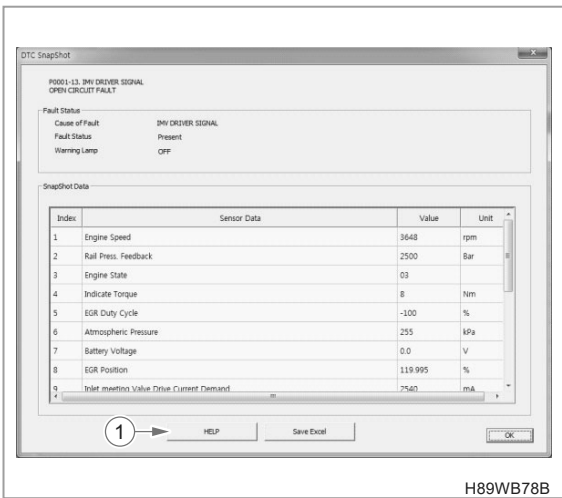

H89WB78B

- Click HELP(1) button and Fault code help file will be opened.

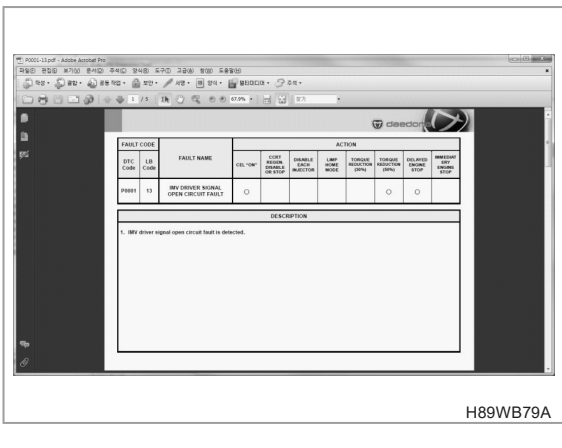

H89WB79A

## ► DATA MONITORING

The screenshot shows the Data Monitoring interface. At the top, a menu is visible with options: Stop, Fault Codes, Data Monitoring (highlighted with a dashed border), and CAN Monitoring. Below this, the main interface features a 'Snapshot' section with buttons for 'Auto Start', 'Manual Start', and 'Stop'. A 'Frame =' field is also present. Below these are buttons for 'Graph', 'Save as Excel', 'Save Selection', and 'Open Selection'. A dropdown menu is set to 'All', with radio buttons for 'All' and 'Sel'. A table of service data is displayed below, with a 'Sel' column for selecting items. The table has columns for 'Sel', 'Num', 'Service Data', 'Value', and 'Unit'. The data rows are as follows:

Sel	Num	Service Data	Value	Unit
<input type="checkbox"/>	001	Indicate Torque	0	Nm
<input type="checkbox"/>	002	Atmospheric Pressure	99	kPa
<input type="checkbox"/>	003	Fuel Demand	0.0	mg/stroke
<input type="checkbox"/>	004	Rail Press. Demand	150	Bar
<input type="checkbox"/>	006	Engine State	00	
<input type="checkbox"/>	008	Engine Speed	0	rpm
<input type="checkbox"/>	009	CAM Speed	0	rpm

Annotations 1 through 9 and A through C point to specific UI elements: 1 (Snapshot), 2 (Auto Start), 3 (Manual Start), 4 (Stop), 5 (Frame =), B (Save Selection), C (Open Selection), 6 (Dropdown menu), 7 (All radio button), 8 (Sel radio button), 9 (Graph button), A (Save as Excel), and D (Sel checkbox in table).

H89WB80B

- Click Data Monitoring, you can check Engine data value.

- (1) Activate Snapshot function.
- (2) Start Auto Start function.
- (3) Save Snapshot Data.
- (4) Stop Data saving.
- (5) Indicating saved Snapshot frame.
- (6) Choose Data Group that will be indicated on screen.
- (7) Indicating All data of chosen group.
- (8) Indicating checked data from D section only.
- (9) Indicating data indicated from Step 8 as Graph.
- (A) Save indicated data as Excel.
- (B) Save data list indicated from Step 8.
- (C) Open data saved from B.
- (D) Select/cancel each item.

**A. SAVE SANPSHOT**



H89WB81A

- Function that saves currently indicated data value.
    - Auto Start : Save data based on Before/After occurrence of Fault Codes.
    - Manual Start : Save data based on Before/After click button.
1. Check Snapshot and button will activate.
  2. Click Start button and Stop button will activate.
  3. Click Stop button and save file.
  4. You can check saved Snapshot file by Snapshot function of main menu

**B. GROUP SELECTION**

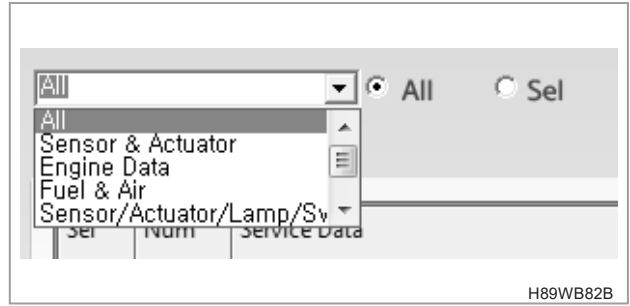

H89WB82B

- Can select Data by Group.

**ALL SELECT**

Sel	Num	Service Data	Value	Unit
<input checked="" type="checkbox"/>	001	Indicate Torque	0	Nm
<input checked="" type="checkbox"/>	002	Atmospheric Pressure	102	kPa
<input type="checkbox"/>	003	Fuel Demand	0.0	mg/stroke
<input type="checkbox"/>	004	Rail Press. Demand	150	Bar
<input type="checkbox"/>	005	EGR Duty Cycle	0	%
<input type="checkbox"/>	006	Engine State	00	
<input type="checkbox"/>	007	ACV Duty Cycle	0	%
<input checked="" type="checkbox"/>	008	Engine Speed	0	rpm
<input type="checkbox"/>	009	CAM Speed	0	rpm
<input checked="" type="checkbox"/>	010	Pedal Position	0	%
<input checked="" type="checkbox"/>	011	Brake Switch	00	
<input type="checkbox"/>	012	MDP Correction Data [In 1 (Zone 0)]	0	us

H89WB83B

**AFTER TREATMENT SELECT**

Sel	Num	Service Data	Value	Unit
<input type="checkbox"/>	059	Ash Learn Failed	0	-
<input type="checkbox"/>	060	Ash Learn Success	0	-
<input type="checkbox"/>	061	Engine Run Time at Last Regen.	0	s
<input type="checkbox"/>	062	Model Soot Mass_gram	0.0	g
<input type="checkbox"/>	063	DPF Regen Total Time	0	s
<input type="checkbox"/>	072	DPF Delta Press.	0	kPa
<input type="checkbox"/>	148	Soot Mass_리센트	0	%
<input type="checkbox"/>	149	DPF Regen State	00	
<input type="checkbox"/>	156	DPF In Temp.	1000	°C

H89WB84B

**C. ALL/SELECT**

**C-1. SELECT DATA THAT WILL BE INDICATED**

Sel	Num	Service Data	Value	Unit
<input checked="" type="checkbox"/>	059	Ash Learn Failed	0	-
<input type="checkbox"/>	060	Ash Learn Success	0	-
<input checked="" type="checkbox"/>	061	Engine Run Time at Last Regen.	0	s
<input type="checkbox"/>	062	Model Soot Mass_gram	0.0	g
<input checked="" type="checkbox"/>	063	DPF Regen Total Time	0	s
<input type="checkbox"/>	072	DPF Delta Press.	0	kPa
<input checked="" type="checkbox"/>	148	Soot Mass_퍼센트	0	%
<input type="checkbox"/>	149	DPF Regen State	00	
<input type="checkbox"/>	156	DPF In Temp.	1000	°C

H89WB85B

**C-2. CLICK SELECT BUTTON**



- Can indicate selected data among displayed data.

**C-3. INDICATE SELECTED ITEM**

Sel	Num	Service Data	Value	Unit
<input checked="" type="checkbox"/>	059	Ash Learn Failed	0	-
<input checked="" type="checkbox"/>	061	Engine Run Time at Last Regen.	0	s
<input checked="" type="checkbox"/>	063	DPF Regen Total Time	0	s
<input checked="" type="checkbox"/>	148	Soot Mass_퍼센트	0	%

H89WB87B

**C-4. INDICATE ALL ITEM**

- When you select 'All' from C-2, No.1 will be shown.
- Select 'All' again, checked item will be released.



D. GRAPH

- After progress until "C" of C-3, click graph button and selected item value can be seen as Graph

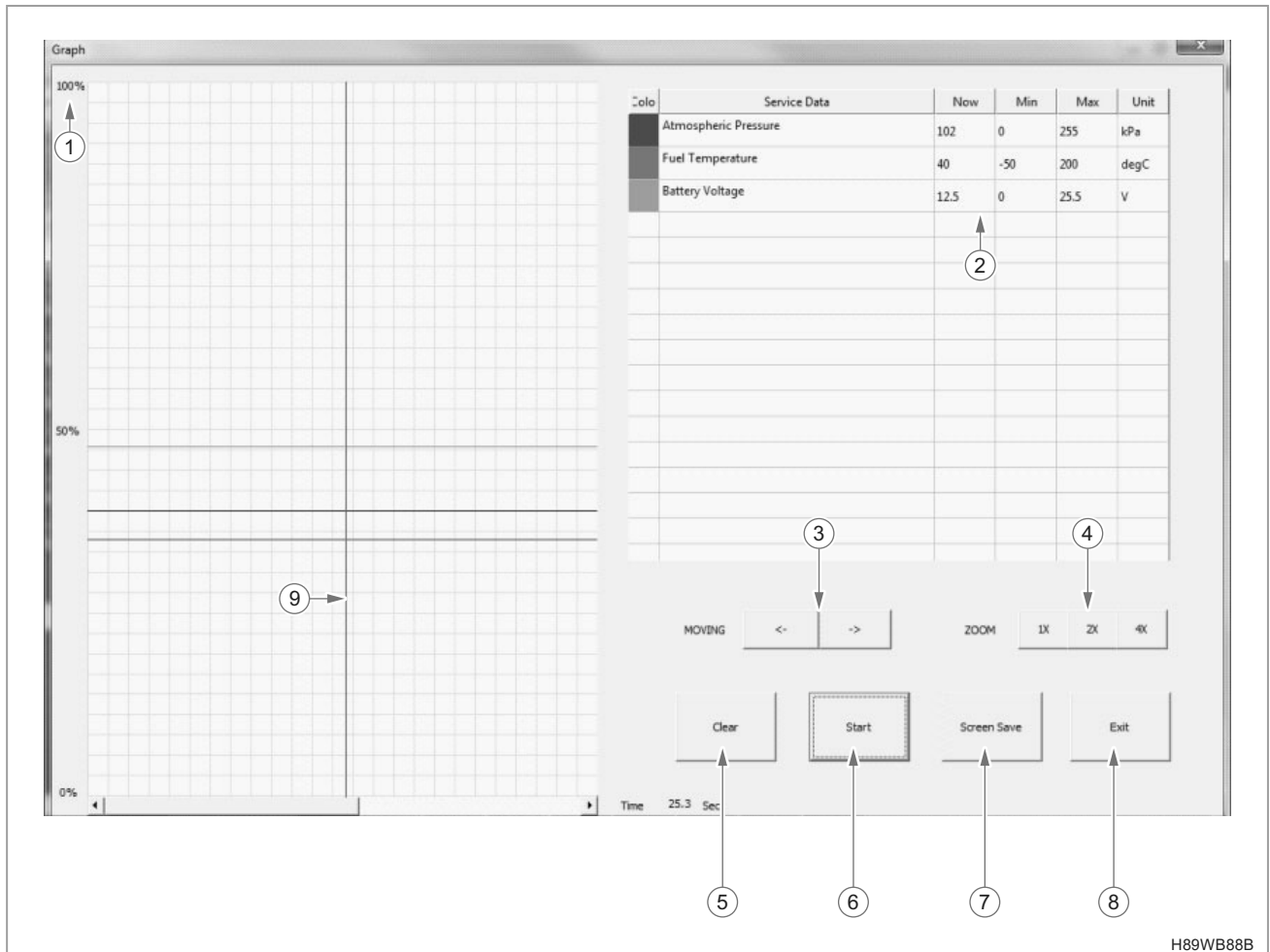

H89WB88B

- (1) Indicating min/max standard of sensor value as 0~100%. Sensor will be separated by color.
- (2) Indicate sensor value. Click min/max value and can change standard value.
- (3) When graph stops, move standard line no.(9) as left/right.
- (4) Can magnify no.1 screen double/ quadruple to Time axis.
- (5) Delete graph screen.
- (6) Start/Stop : Start or stop indicating graph.
- (7) Save graph screen as image file.
- (8) Exit graph screen.

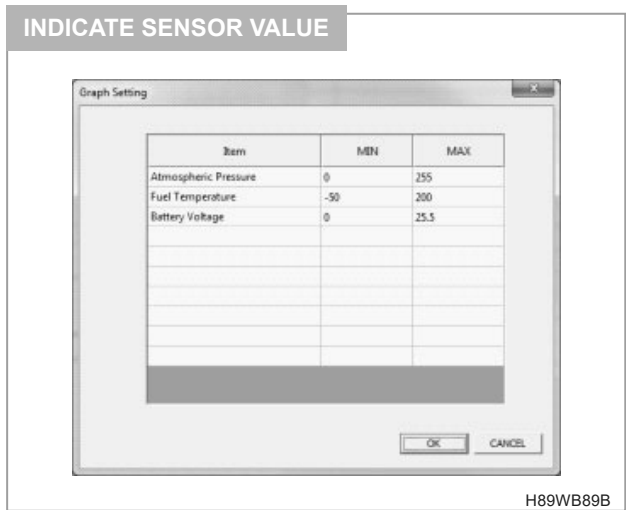

H89WB89B

E. SELECT ITEM

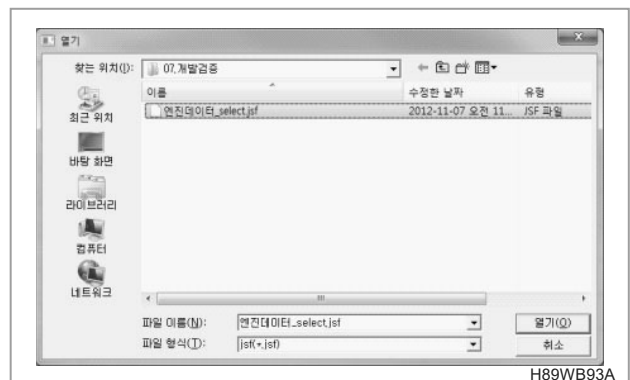
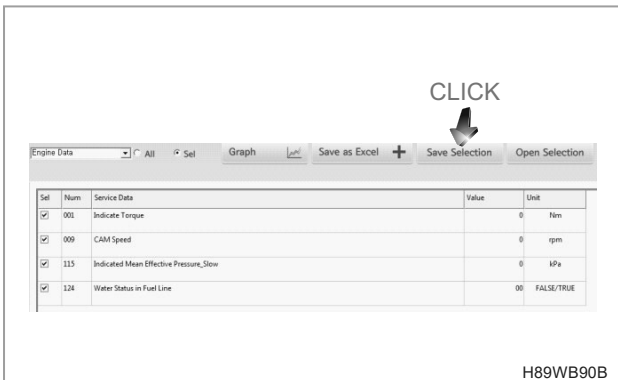

- If you select/save frequent item, you can check selected data by opening applicable file when you run next program. After select C-3, click Save Selection button. Save selected item as selectable name.

Selected System Display

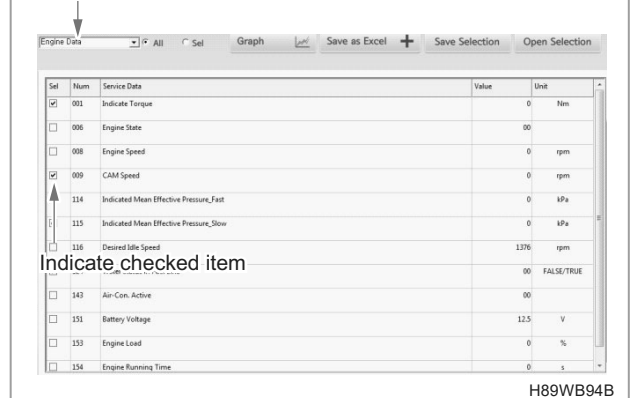

- When you click Selection button, selected item will be indicated only.

▶ SNAP SHOT

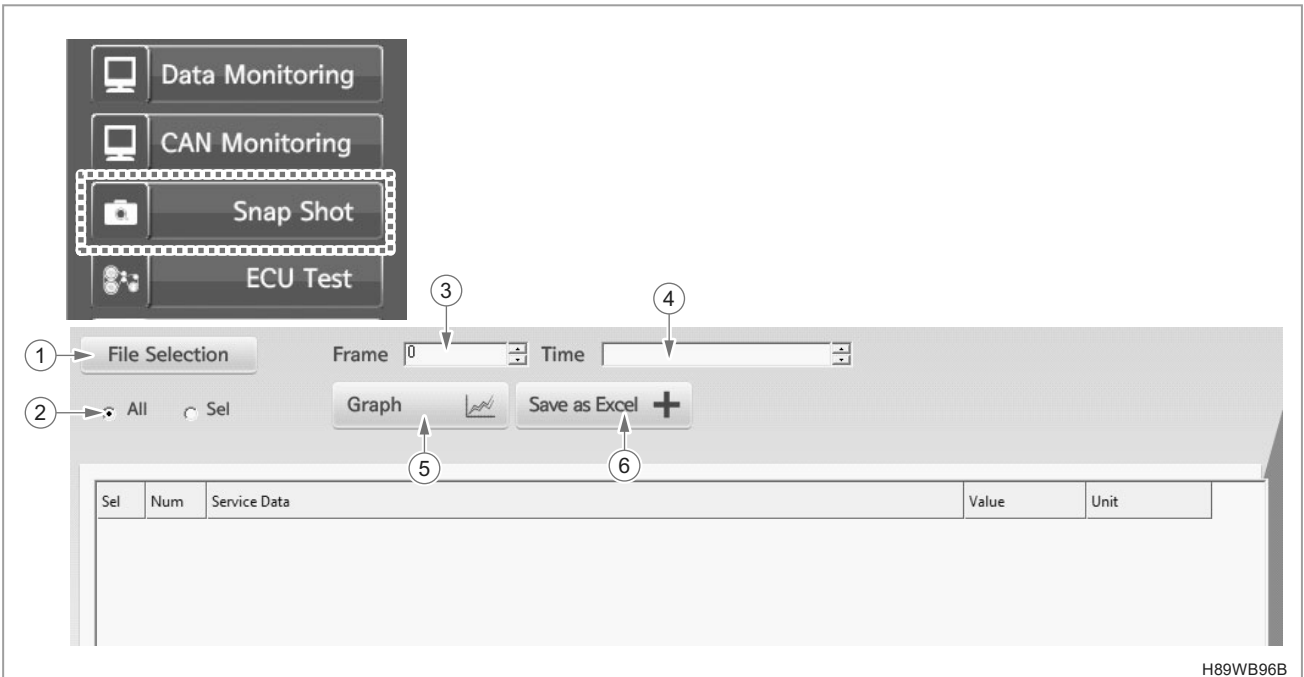

H89WB96B

- When you click Snap Shot button, Snap Shot screen will be displayed. You can check saved data.
  - (1) Select data saving file.
  - (2) Select wanted item from data items.
  - (3) Frame number that is shown on screen.
  - (4) Save Time of applicable frame.
  - (5) Indicating selected item as graph.
  - (6) Save current screen contents as excel.

A. SELECT FILE

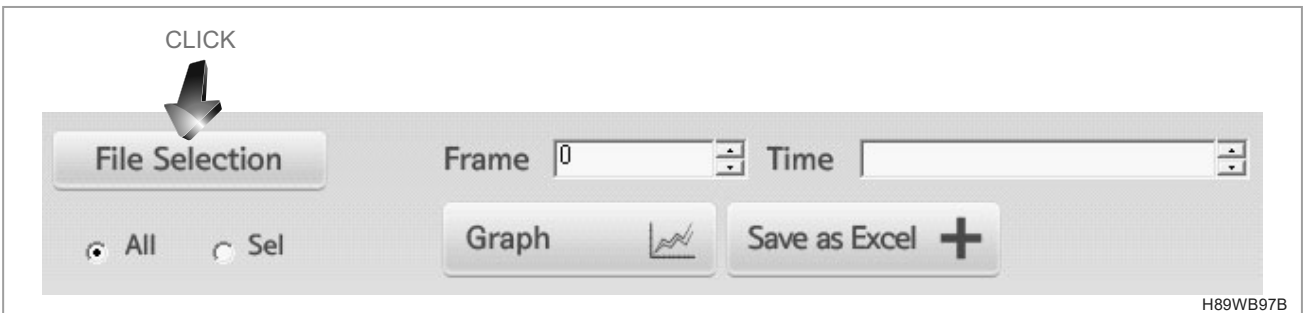

H89WB97B

- Click File Selection



H89WB98B

- Choose File.

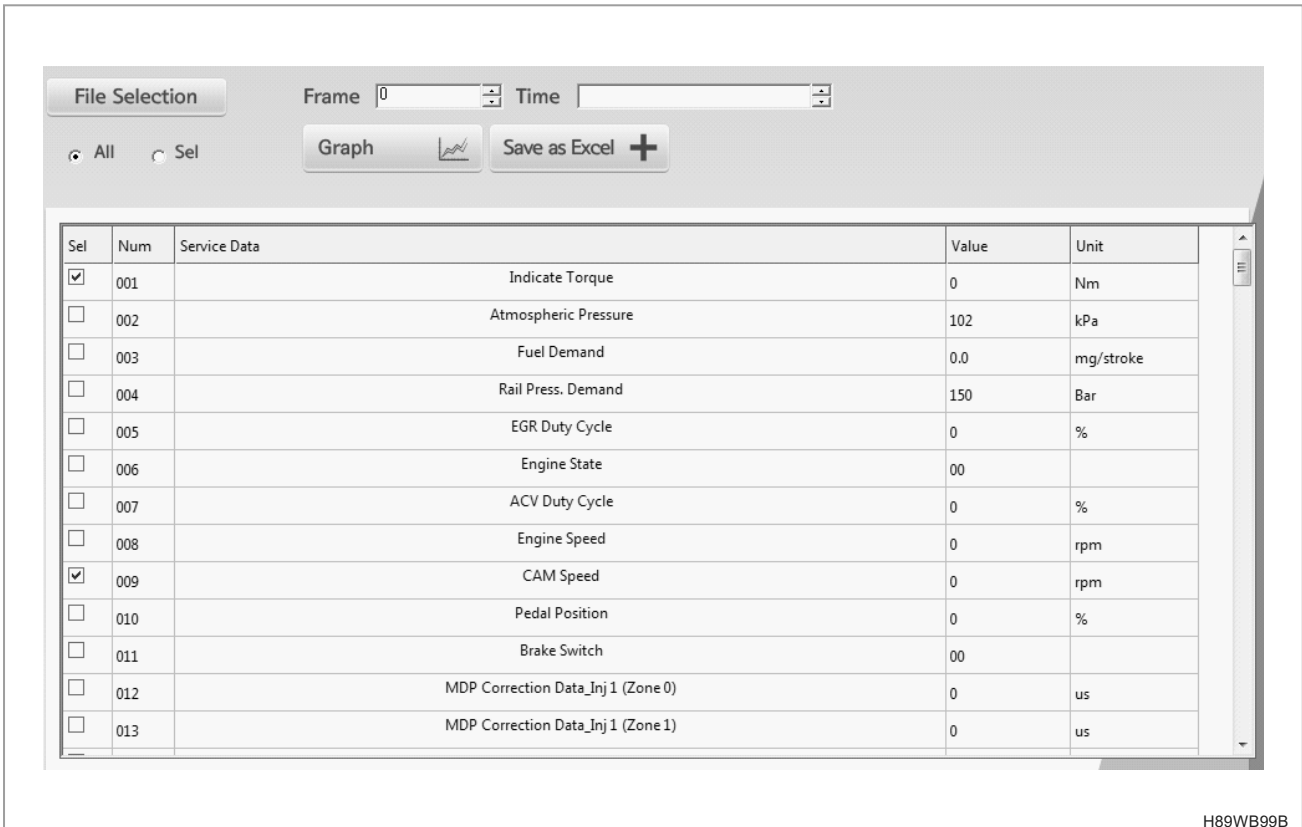

H89WB99B

- Indicate saved data.

**B. FRAME CHANGE**

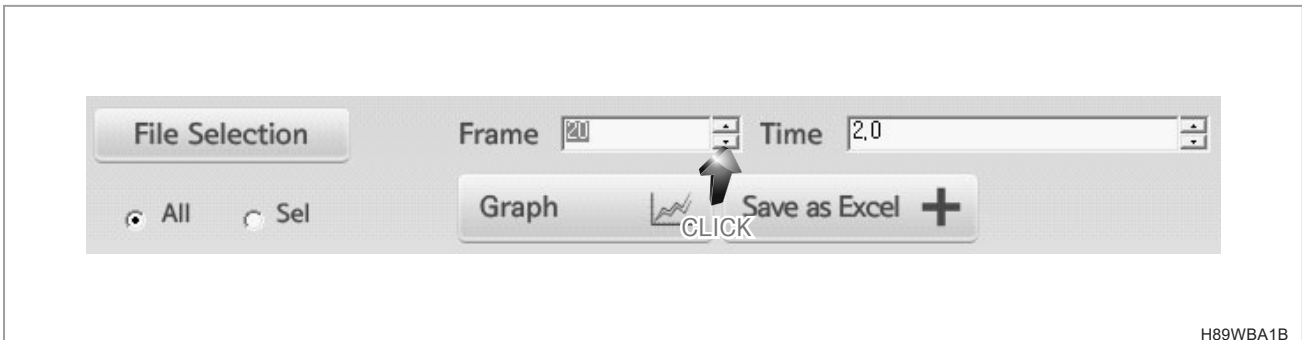

H89WBA1B

- When you click arrows next to Frame section, Frame will be changed. When Frame is changed, data value of applicable Frame will be indicated. Time of applicable Frame will be indicated on right.

**C. GRAPH**

- Graph function is the same with Graph function of Data Monitoring.

**D. SAVE AS EXCEL**

- Function of saving as excel is the same with Graph function of Data monitoring.

▶ ENGINE TEST

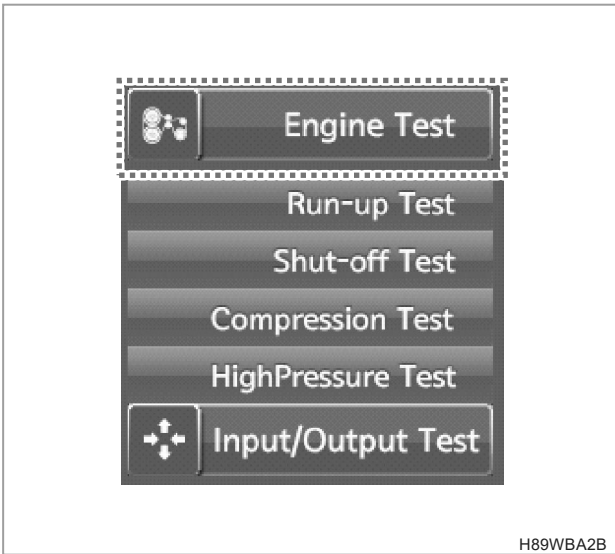

- When you click Engine Test, Run-up Test, Shut-off Test, Compression Test and High Pressure Test will be shown at the bottom.
  - Run-up Test: Grasp the differences of individual cylinder's power ability.
  - Shut-off Test: Check injector efficiency of individual cylinder.
  - Compression Test: Check speed of pistons.
  - HighPressure Test: Check fuel rail pressure change.

H89WBA2B

A. RUN-UP TEST

FT4Scan

1. Supply the same amount of fuel to all injectors and measure the time until engine speed goes up to 2,500 rpm.  
 2. Stop the injector one by one and measure engine rpm during the time measured first.  
 -> If any injector rpm gradient is very different from the others, that injector needs to be checked.

확인

Color	Cylinder	A(ms)	B(ms)
none		940.000	1480.000
1	1	960.000	1000.000
2	2	920.000	1140.000
3	3	980.000	980.000
4	4	940.000	1080.000

Desc	Value	Unit	Condition
Engine Speed	0	rpm	800~2800RPM
Clutch	0		Engaged : 00
Brake	0		On : 01
Pedal Position	0	%	Below 5%
Coolant Temp.	20.0	degC	60 ~ 120 degC

OK

H89WBA3B

- (1) Click Run-up Test, Test terms will be shown.
- (2) Click Auto Start button, Test will be started.
  - If it doesn't meet the terms, it will not be started.
  - It will be progressed from no.1 cylinder to no.4 cylinder in order.
- (3) When Test is completed, result value will be shown.
- (3) Each cylinder's gradient of rising section and falling section will be indicated.
  - In case of normal, rising section should be indicated as the same gradient except Blue. In case of normal, all falling section should be shown as the same gradient.
  - When gradient is different, you can expect there's error in cylinder.
4. Click "Help" button, Test description display.

**B. SHUT-OFF TEST**

The screenshot shows the FT4Scan software interface for the Shut-Off Test. At the top, there is a control bar with buttons labeled 'Auto Start', 'NONE', '1', '3', '4', '2', 'Stop', and 'Help'. A 'Graph' section contains a 'Cylinder' selection table with options: None, 1, 3, 4, 2. A 'Test Condition' dialog box is open, showing a table with columns: Desc, Value, Unit, and Condition. The table contains the following data:

Desc	Value	Unit	Condition
Engine Speed	0	rpm	800~2800RPM
Clutch	0		Engaged : 00
Brake	0		On : 01
Pedal Position	0	%	Below 5%
Coolant Temp.	20.0	degC	60 ~ 120 degC

A 'Help' dialog box is also visible, containing the following text:

1. Keep engine speed 1,500 rpm with all injectors and measure fuel amount consumed.  
 2. Stop the injector one by one and keep 1,500 rpm and then measure fuel amount consumed by the other injectors.  
 ->If any fuel amount rate is very different from the others, that injector needs to be checked.

H89WBA4B

- (1) Click Shut-Off Test, Test terms will be indicated.
- (2) In case of testing, indicate sensor value.
- (3) Click Auto Start button, it will progress as NONE, 1, 3, 4, 2 order.  
 - When it doesn't meet terms, it won't be started.
- (4) You can test individually by each cylinder.
- (5) Indicate Test Result.  
 - In case of NONE, indicate Fuel injection quantity as (100%) based on Fuel injection ratio.  
 - Indicate result in case of Auto Start only.
- (6) Click "Help" button, Test description display.

C. COMPRESSION TEST

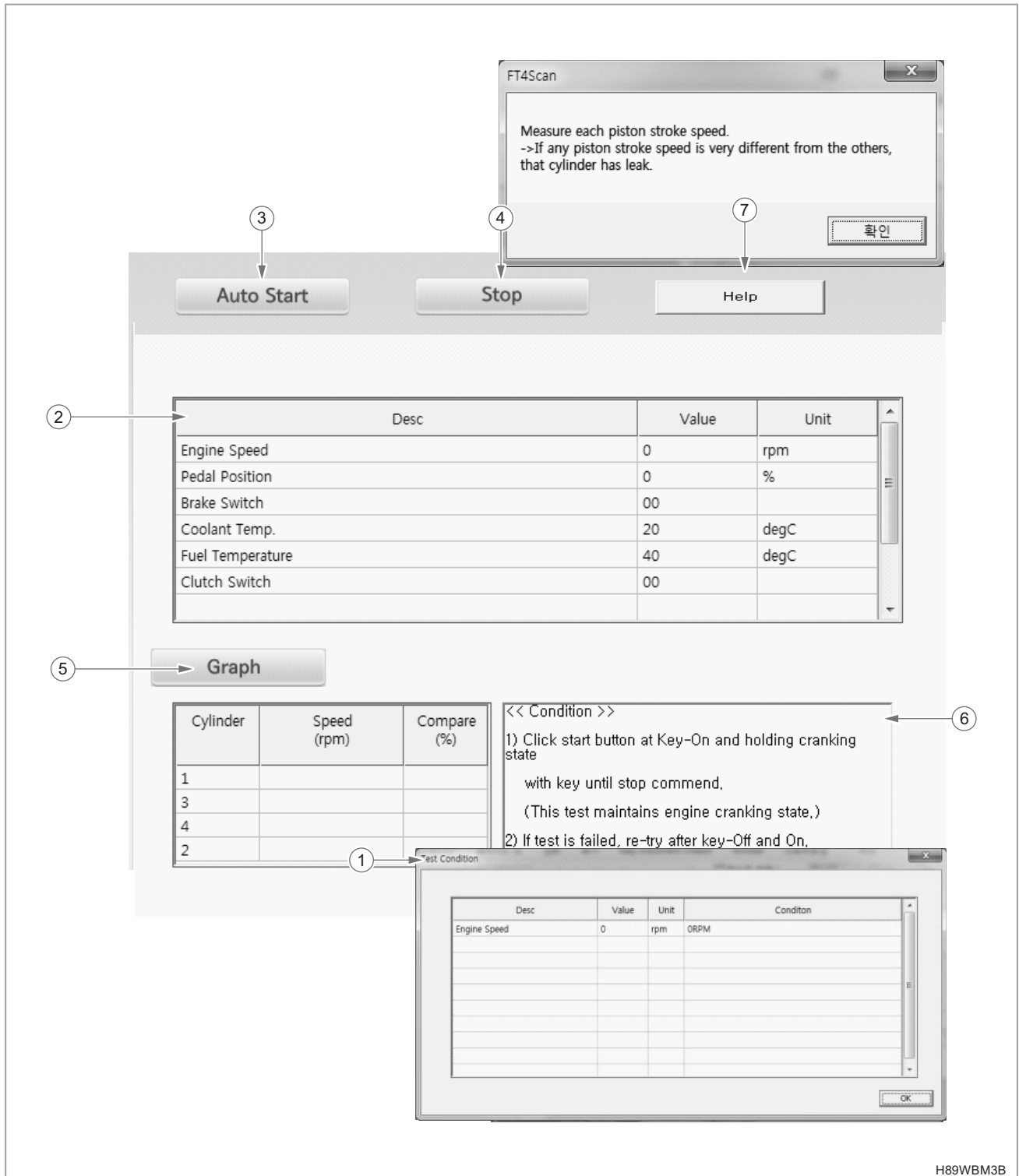

H89WBM3B

- (1) Click Compression Test, Test terms will be shown.
- (2) In case of Testing, indicate related sensor value.
- (3) Click Auto Start button, Cranking until stop command appears.
  - When it doesn't meet terms, it won't be started.
- (4) Click Stop button to stop Test.
- (5) Indicate Test Result.
  - Indicate comparing value based on the highest Fuel injection time.
- (6) Explain Test terms.
- (7) Click "Help" button, Test description display.

SAFETY FIRST

ENGINE

DRIVING & CHASSIS

HYDRAULIC SYSTEM

ELECTRIC SYSTEM

CABIN

INDEX

D. HIGH PRESSURE TEST

FT4Scan

Check the response of rail pressure by ECU demand up to 1800 bar.

확인

Auto Start Stop Help

Desc	Value	Unit
Engine Speed	0	rpm
Pedal Position	0	%
Brake Switch	00	
Coolant Temp.	20	degC
Fuel Temperature	40	degC
Clutch Switch	00	

Graph

Result

Test Condition

Desc	Value	Unit	Conditon
Coolant Temp.	20.0	degC	0 ~ 95degC
Fuel Temp.	40.0	degC	20-80degC
Pedal Position	0	%	Below 5%

<< Condition >>

- 1) Coolant Temp. : 0~95degC
- 2) Fuel Temp. : 20~80degC
- 3) Pedal Position: Below 5
- 4) Click start button at Key-On and start the engine with key.  
(Engine is off after this test is automatically performed.)
- 5) If test is failed, re-try after key-Off and On.
- 6) After finishing this test, you should be key-off.

OK

H89WBM4B

- (1) Click High Pressure Test button, Test terms will be shown.
- (2) In case of Testing, indicate related sensor value.
- (3) Click Auto Start button, Cranking. Then, engine will be on and test will be started.  
- When it doesn't meet terms, it won't be started.

- (4) Click Stop button to stop Test.
- (5) Indicate Test Result.
- (6) Explain Test terms.
- (7) Click "Help" button, Test description display.



▶ INPUT/OUTPUT TEST

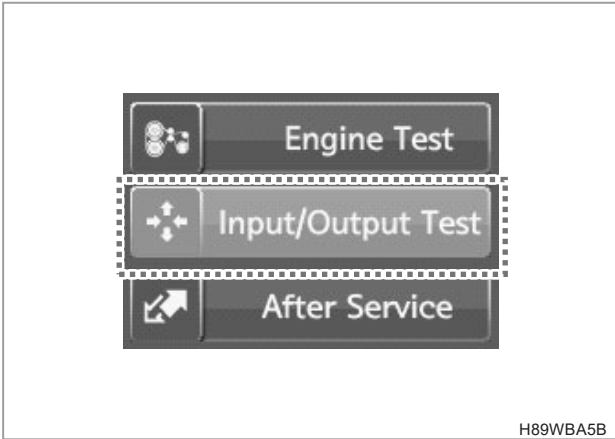

- Can test Actuator item by Input/Output Test.
- Test Item
 

(1) Throttle Actuator	(7) Water In Fuel Lamp
(2) EGR Valve	(8) DPF Underway Lamp
(3) Glow Plug	(9) Regen Warning Lamp
(4) HP Pump/IMV Valve	(10) PTO Cruise Lamp
(5) Check Engine Lamp	(11) RPM Guage
(6) Glow Plug Lamp	(12) Injector

A. SCREEN EXPLANATION

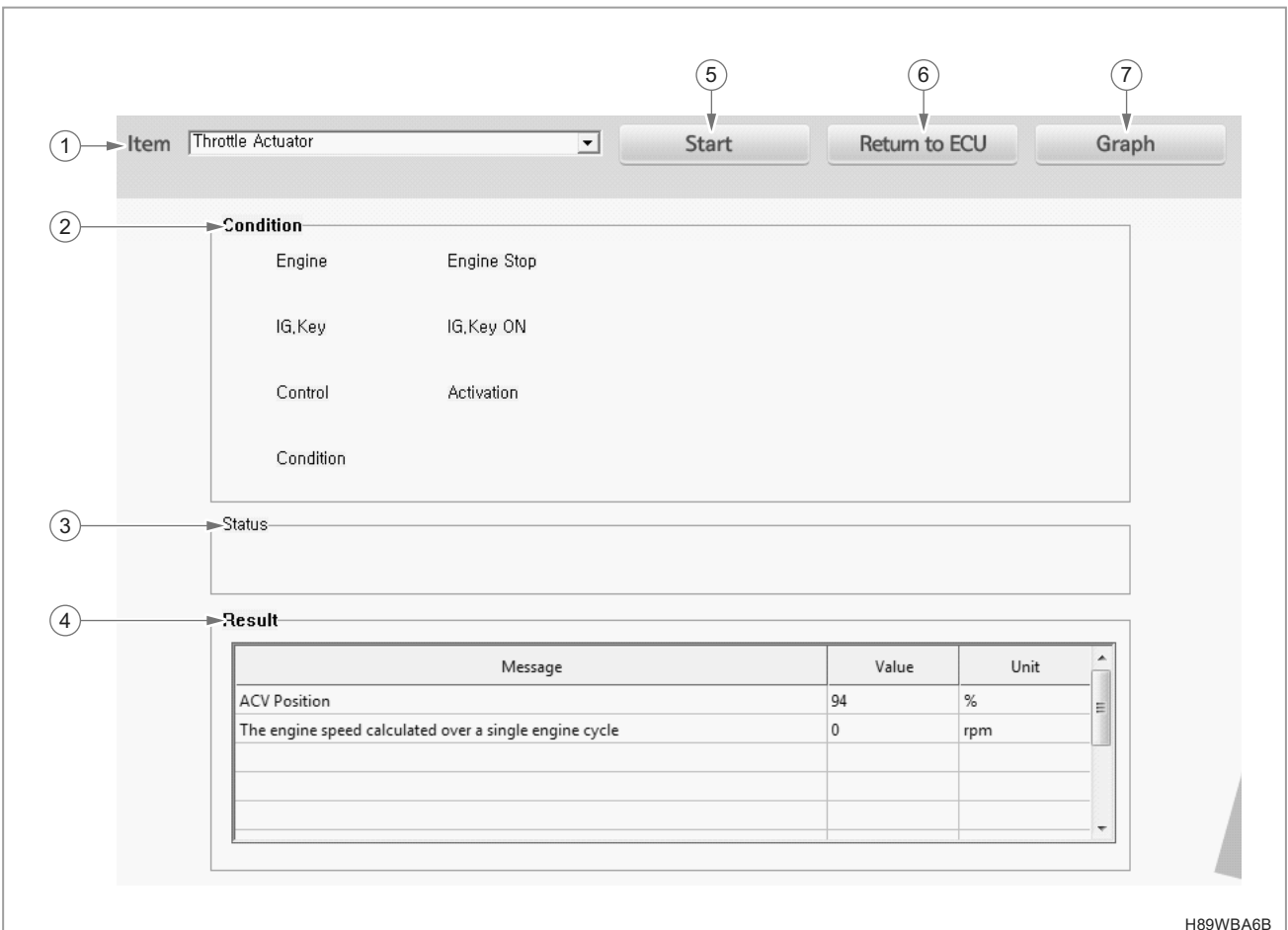

- (1) Select Input/Output Test item.
- (2) Indicate conditions for Test.
- (3) Indicate Test status.
- (4) Indicate Data value that needs to be checked for Test.

- (5) Start Test.
- (6) Stop Test.
- (7) Data value will be shown as Graph.

### ► AFTER SERVICE

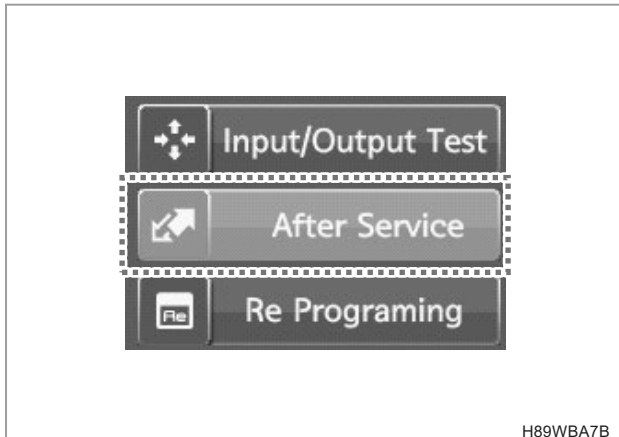

- Click After Service button, lower items will be shown.

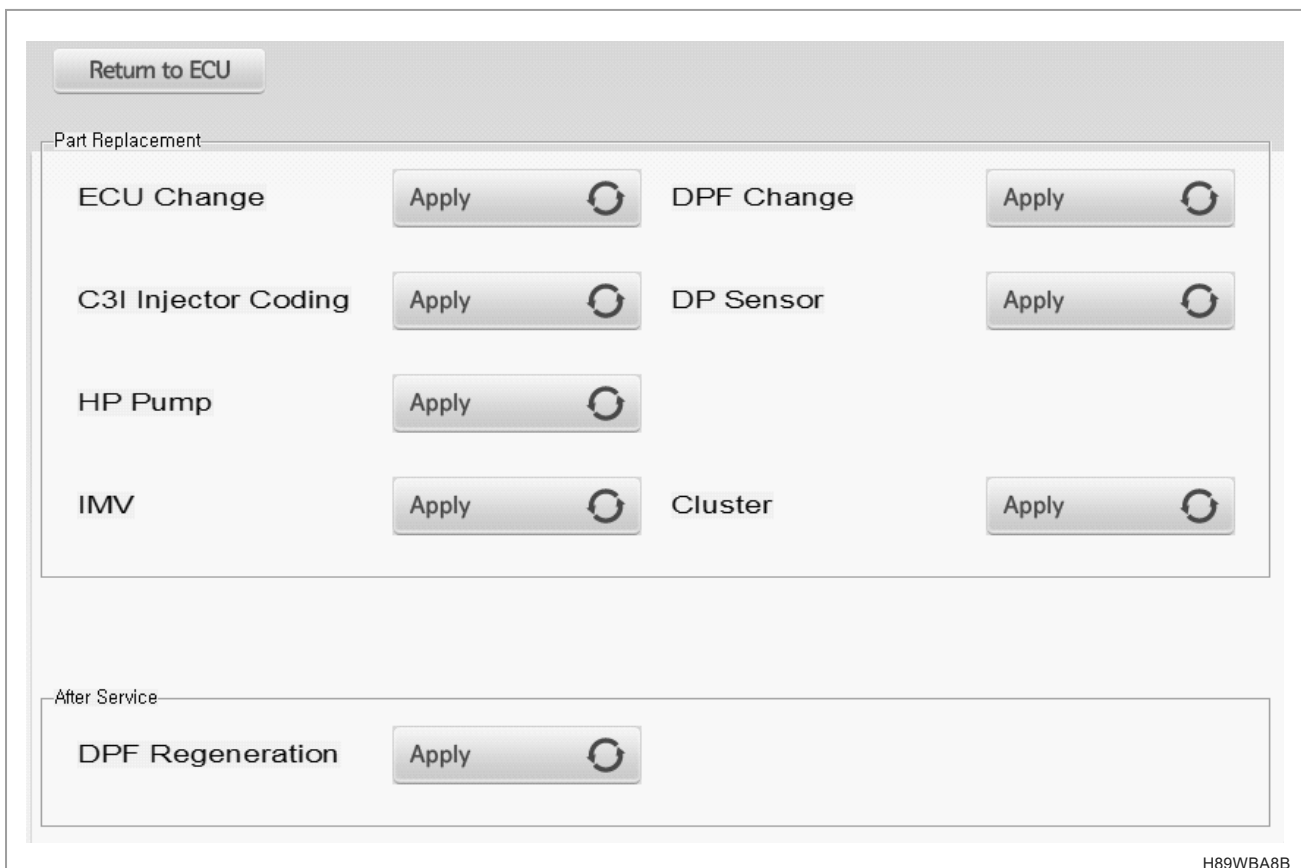

- In case of replace Part Replacement item, Click Apply button and apply replacement issue to ECU.
- Progress After Service item in case of need.
- If you want to stop working, click Return button.

A. ECU CHANGE



H89WBA9B

1. Click ECU Data Download Button.

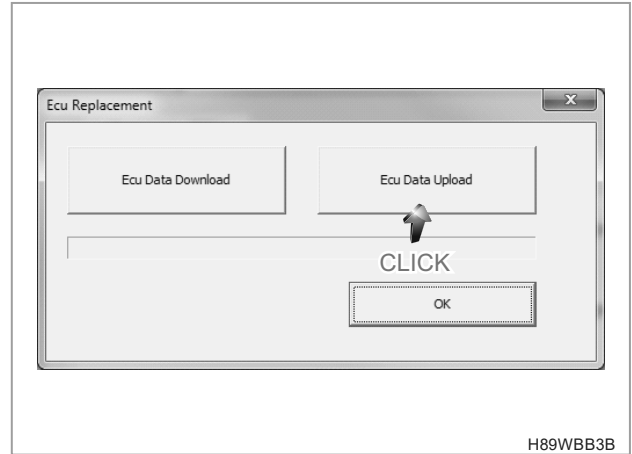

H89WBB3B

4. After replacing ECU, click ECU Data Upload button.

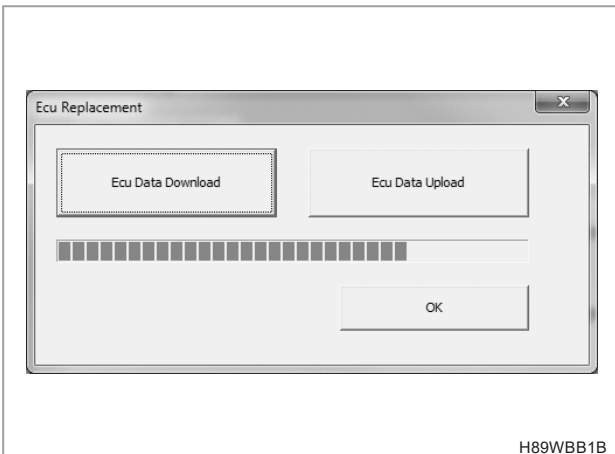

H89WBB1B

2. Download ECU Data.

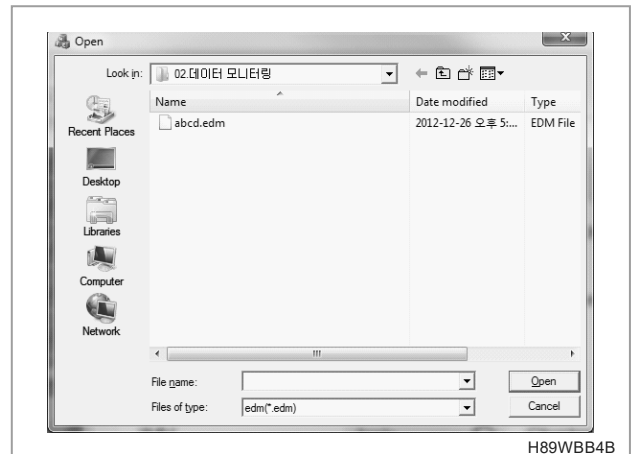

H89WBB4B

5. Select data file.

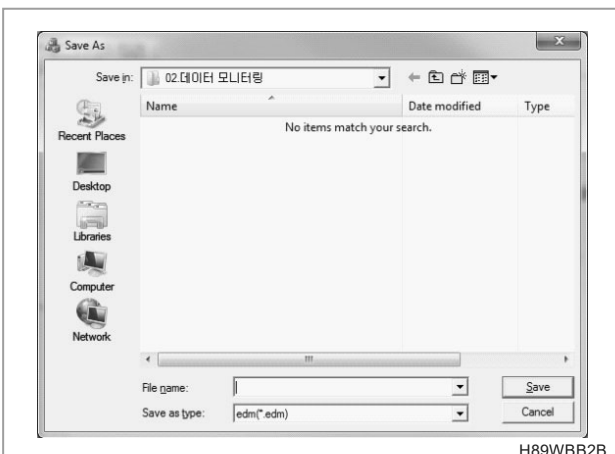

H89WBB2B

3. Save Download data as file.

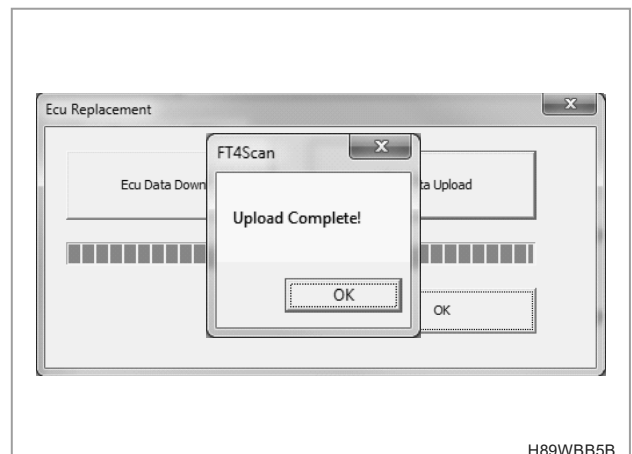

H89WBB5B

6. Upload Complete message will be shown.

**REMARK**

- In case of replace ECU, download ECU Data on PC first. After the replacing ECU, please upload downloaded ECU Data.

**B. INJECTOR CODING**

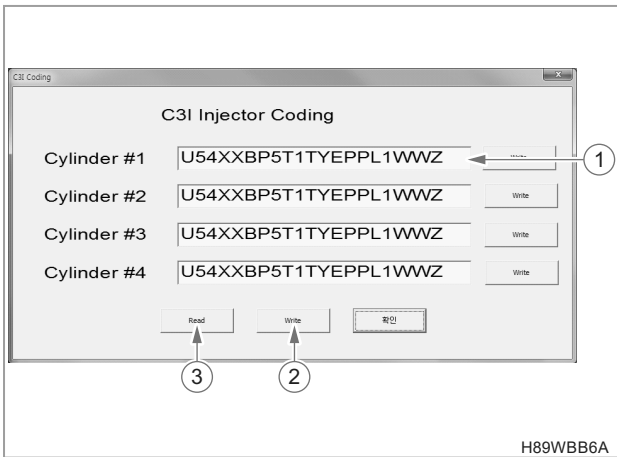

- (1) Enter replaced injector number.
- (2) Click Write button.
- (3) Click Read button, check it.
- In case of replacing Injector, enter installed injector's No. (20 digits).

**C. CLUSTER**

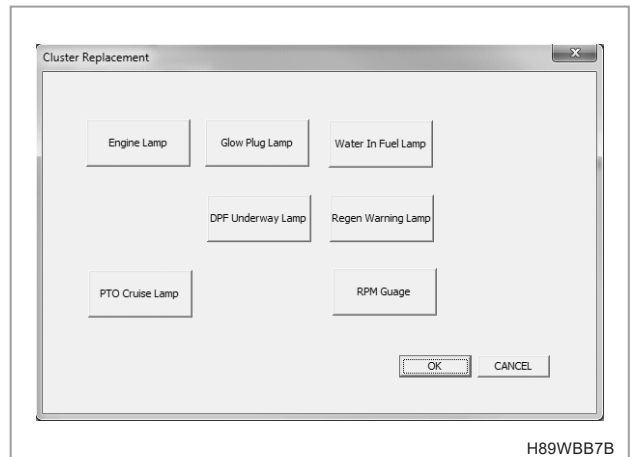

- In case of replace Cluster, Please check whether Lamp operates normally.
- Click each item and applicable Lamp or Guage will be operated. At this moment, check the status of applicable Lamp or Guage by Cluster screen.

**D. Others**

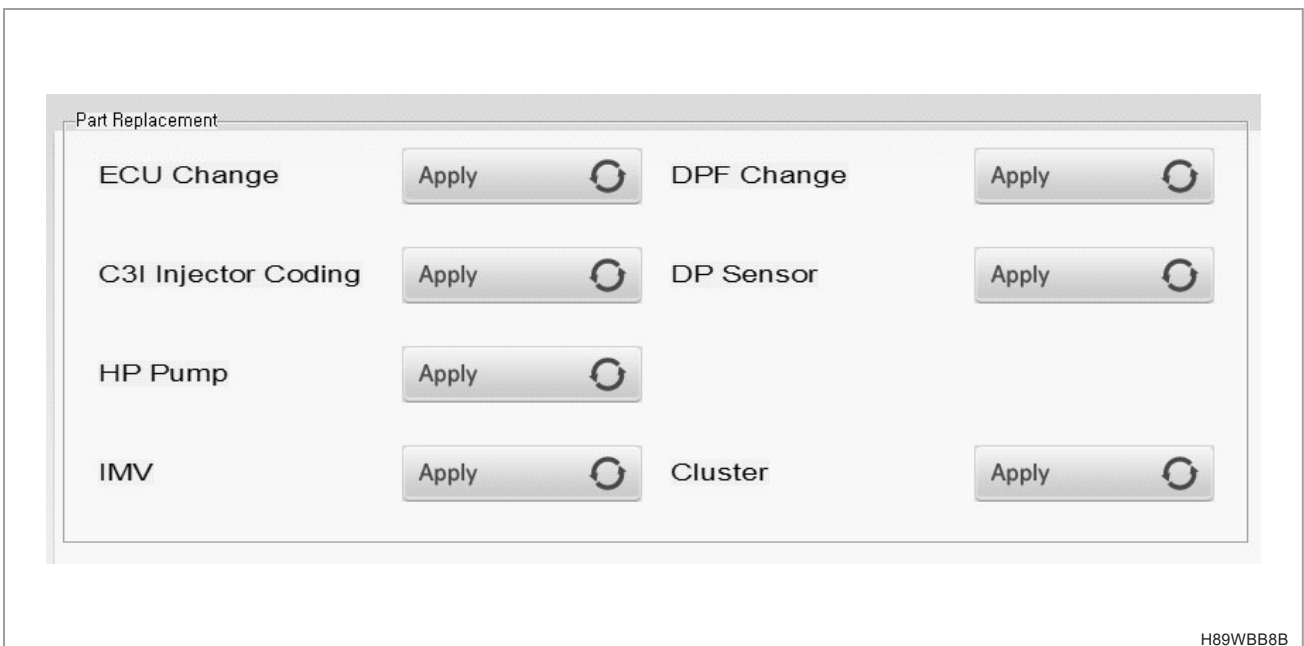

- Besides A ~ C items, it will immediately applied when you click Apply button.

**E. DPF REGENERATION**

- Click DPF Regeneration's Apply button, it will progress Regeneration.

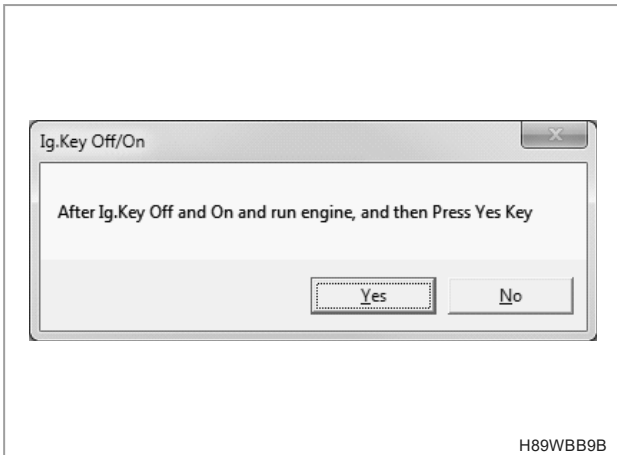

H89WBB9B

- Click DPF Regeneration Apply button, 'Run Engine' message will be shown.



H89WBC3B

- If it doesn't meet Test conditions, Error message will be shown.



H89WBC1B

- Click 'Yes' button to continue.



H89WBC4B

- If it meets Test conditions, it will start DPF Regeneration. But when applying is aborted, Error message will be shown.

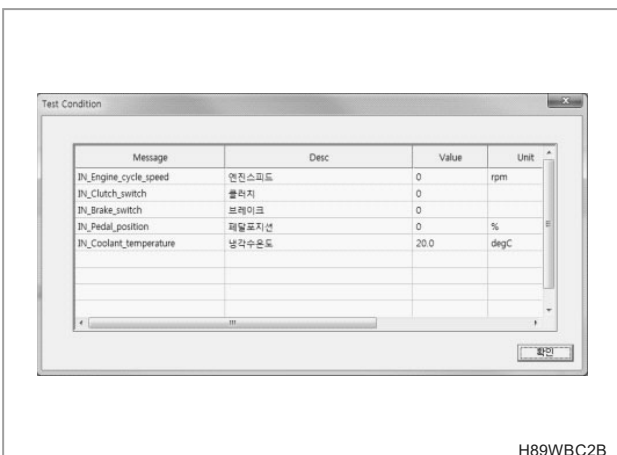

H89WBC2B

- Test conditions will be shown.

## ▶ REPROGRAM



- Reprogram function is entering update file to ECU when software of ECU is updated. Click Reprogram button and it will be shown as below.

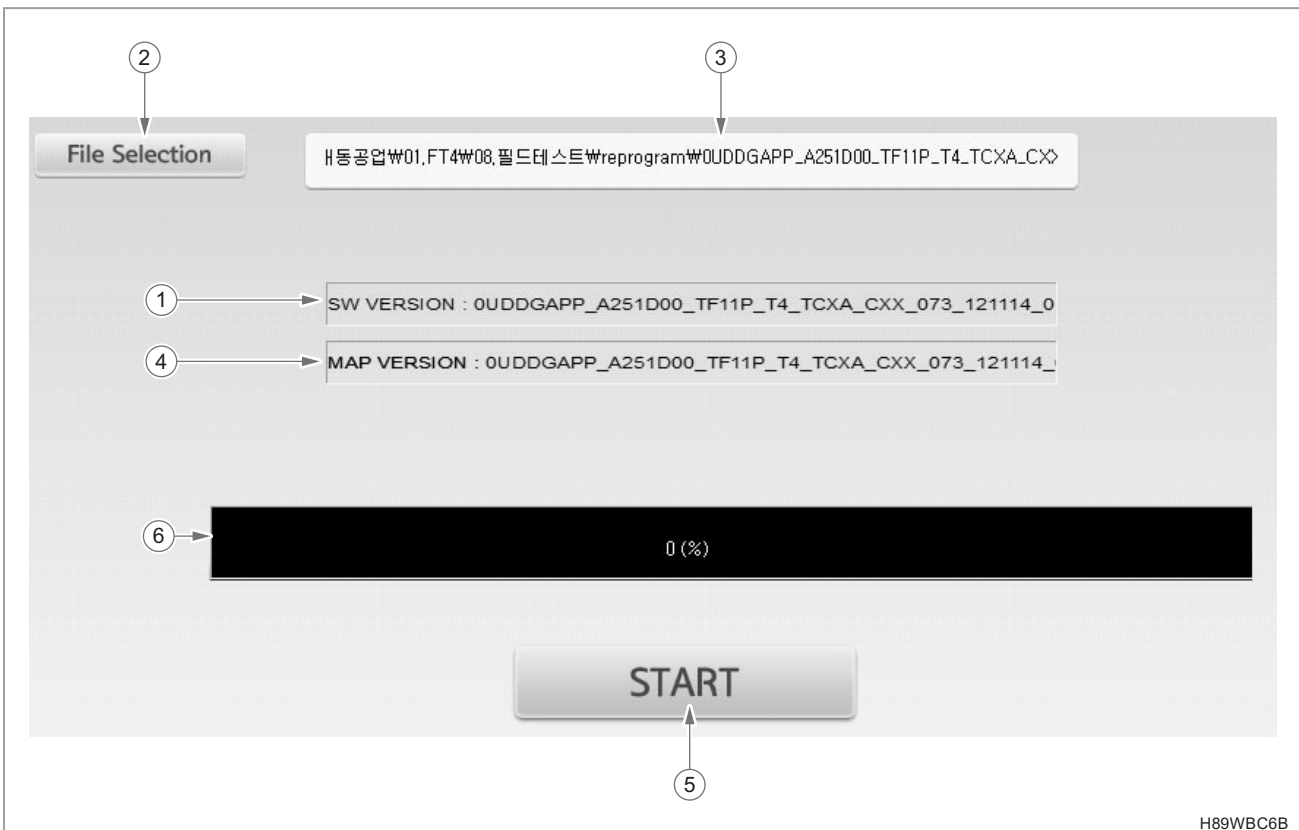

- (1) SW version of ECU will be indicated.
- (2) Select file.
- (3) Reprogram file route will be indicated.
- (4) MAP version of file will be indicated.
- (5) Start button will be activated.
- (6) Click Start button and rate of progress will be indicated.

► ECU INFORMATION



Engine			
Engine Company	KIOTI	After Treatment	DOC+CRT+SCR+AOC
Engine Type	4F243T(A)	Date(YY/MM/DD)	17/04/04
Emission	Tier4 Final / Stage IIIB	Flashing User Info	112233445502
Induction System	Turbo charged	Last Programming Date	17/04/12
H/W Variant	Z		
ECU		DCU	
S/W Sequence	01	S/W Version	00 /05 / 02
Calibration ID	6424-2584-001	Calibration ID	CE12_085_R0406_1

H89WBC8B

## 8.2 DTC (DIAGNOSTIC TROUBLE CODE)

### 8.2.1 COMPOSITION

#### OVERVIEW

##### ► DTC and LB code

These are unified by SAE for errors occurred by use of the ECU.

##### ► SPN AND FMI CODE

Error code displayed in instrument panel.

##### ► FAULT NAME

Fault name for the corresponding fault code

##### ► ACTION

Seven different operations that the ECU performs according to the error code

1. Illuminating Engine CHECK lamp: it turns on the engine CHECK lamp on the instrument cluster to warn the driver about the engine malfunction.
2. Engine stop: it stops the engine after a certain period of time to reduce stress applied to the engine.
3. Stopping/interrupting CCRT regeneration: it stops or interrupts the CCRT regeneration process (only for the vehicle model with the CCRT).
4. Increasing idle
5. Deactivating injector: it stops the faulty injector.
6. Limp home mode: it maintains the engine speed to 1,300 to 1,400 RPM enough to drive the vehicle back home.
7. Reducing torque it reduces the engine torque depending on the condition.



ENGINE - DIAGNOSIS

8.2.2 ERROR CODE & ACTION

FAULT CODE						FAULT NAME	DESCRIPTION	ACTION							EGR Inducement		
DTC CODE		J1939		LAMP CODE	CLUSTER CODE			CEL"ON"	DELAYED ENGINE STOP (20s)	CCRT (DPF) REGEN DISABLE OR STOP	INCRE-ASED IDLE (1300 rpm)	DISABLE EACH INJECTOR	LIMP HOME (1400 rpm)	TORQUE REDUCTION (2200 rpm)	EMISSION FAILURE LAMP "ON"	SPEED REDUCTION Warn : N/A Low Level: N/A Severe Level : 60%	TORQUE REDUCTION Warn : N/A Low Level: 25% Severe Level : 50%
HMB	LB	SPN	FMI														
P0001	13	1	18	241	E-ECU-001	IMV DRIVER SIGNAL OPEN CIRCUIT FAULT	1. IMV driver signal open circuit fault is detected.	O	O				O	O			
P0002	23	2	8	353	E-ECU-002	RAIL PRESSURE CONTROL FAULT	1. Rail pressure control fault due to too much high (positive) or low (negative) IMV current trim.	O					O				
P0002	24	2	9	354	E-ECU-003	RAIL PRESSURE CONTROL	1. Rail pressure control fault due to too much high (positive) or low (negative) IMV current trim.	O	O				O				
P0002	1B	2	6	221	E-ECU-004	RAIL PRESSURE CONTROL HIGH FAULT	1. Rail pressure control fault due to too much high (positive) or low (negative) IMV current trim.	O	O			O	O				
P0002	1A	2	5	222	E-ECU-005	RAIL PRESSURE CONTROL LOW FAULT	1. Rail pressure control fault due to too much high (positive) or low (negative) IMV current trim.	O	O			O	O				
P0003	18	3	3	224	E-ECU-006	IMV FEEDBACK CURRENT LOW FAULT	1. IMV driver short circuit to ground (sc2g) fault is detected. 2. Rail pressure control feedback is too low.	O									
P0003	24	3	5	235	E-ECU-007	IMV CONTROL FAULT 2	1. IMV driver short circuit to ground (sc2g) fault is detected. 2. Rail pressure control feedback is too low.	O									
P0003	23	3	6	234	E-ECU-008	IMV CONTROL FAULT 2	1. IMV driver short circuit to ground (sc2g) fault is detected. 2. Rail pressure control feedback is too low.	O									
P0003	11	3	20	242	E-ECU-009	IMV DRIVER SC2G FAULT	1. IMV driver short circuit to ground (sc2g) fault is detected. 2. Rail pressure control feedback is too low.	O	O			O	O				
P0004	19	4	3	223	E-ECU-010	IMV FEEDBACK CURRENT HIGH FAULT	1. IMV driver signal short circuit to battery (sc2vbatt) fault is detected. 2. Rail pressure control feedback is too high.	O	O			O	O				
P0004	23	4	5	233	E-ECU-011	IMV CONTROL FAULT 2	1. IMV driver signal short circuit to battery (sc2vbatt) fault is detected. 2. Rail pressure control feedback is too high.	O	O			O	O				
P0004	24	4	6	232	E-ECU-012	IMV CONTROL FAULT 1	1. IMV driver signal short circuit to battery (sc2vbatt) fault is detected. 2. Rail pressure control feedback is too high.	O				O					
P0004	12	4	21	243	E-ECU-013	IMV DRIVER SC2VBATT FAULT	1. IMV driver signal short circuit to battery (sc2vbatt) fault is detected. 2. Rail pressure control feedback is too high.	O	O			O	O				
P0004	1B	4	1	231	E-ECU-014	IMV CONTROL FAULT 2	1. IMV driver signal short circuit to battery (sc2vbatt) fault is detected. 2. Rail pressure control feedback is too high.	O									
P0087	00	135	16	334	E-ECU-015	RAIL PRESSURE BUILD FAULT	1. Rail Pressure Build Fault.	O									
P0088	F4	136	16	312	E-ECU-016	OVER RAIL PRESSURE FAULT	1. Rail pressure control error during IMV control (over max calibrated system pressure).	O	O				O				
P0088	00	136	17	311	E-ECU-017	OVER RAIL PRESSURE IMV FAULT	1. Rail pressure control error during IMV control (over max calibrated system pressure).	O	O				O				
P0089	23	137	8	355	E-ECU-018	RAIL PRESSURE CONTROL FAULT	1. Rail pressure control fault. 2. Discharge pressure and error negative or positive.	O					O				
P0089	24	137	9	356	E-ECU-019	RAIL PRESSURE CONTROL FAULT	1. Rail pressure control fault. 2. Discharge pressure and error negative or positive.	O	O				O				
P0093	00	147	16	322	E-ECU-020	RAIL PRESSURE DROP FAULT	1. Rail pressure sensor electrical fault.	O	O				O				
P0096	64	150	1	464	E-ECU-021	INTAKE AIR TEMP. SENSOR FAULT	1. Intake manifold temperature sensor plausibility fault.										
P0097	23	151	20	462	E-ECU-022	INTAKE AIR TEMP. SENSOR SC2G FAULT	1. Intake manifold temperature sensor low fault.	O									
P0098	24	152	18	461	E-ECU-023	INTAKE AIR TEMP. SENSOR OC OR SC2VBATT FAULT	1. Intake manifold temperature sensor high fault.	O									
P0100	00	256	1	481	E-ECU-024	MAF SENSOR FAULT	1. MAF general fault. 2. MAF learning fault.	O									
P0101	64	257	1	485	E-ECU-025	MAF SENSOR FAULT	1. Air mass flow range / performance fault.										
P0101	64	257	1	486		MAF SENSOR FAULT	1. Air mass flow range / performance fault.										
P0102	23	258	20	483	E-ECU-026	MAF SENSOR LOW FAULT	1. Air mass flow is too low or electrical low fault.										

ENGINE - DIAGNOSIS

FAULT CODE						FAULT NAME	DESCRIPTION	ACTION							EGR Inducement		
DTC CODE		J1939		LAMP CODE	CLUSTER CODE			CEL "ON"	DELAYED ENGINE STOP (20s)	CCRT (DPF) REGEN DISABLE OR STOP	INCRE-ASED IDLE (1300 rpm)	DISABLE EACH INJECTOR	LIMP HOME (1400 rpm)	TORQUE REDUCTION (2200 rpm)	EMISSION FAILURE LAMP "ON"	SPEED REDUCTION Warn : N/A Low Level: 60% Severe Level : 60%	TORQUE REDUCTION Warn : N/A Low Level: 25% Severe Level : 50%
HMB	LB	SPN	FMI														
P0103	24	259	18	482	E-ECU-027	MAF SENSOR HIGH FAULT	1. Air mass flow is too high or electrical high fault.										
P0106	24	262	6	473	E-ECU-028	INTAKE AIR PRESS. SENSOR FAULT	1. Intake manifold pressure sensor signal drift fault.	O									
P0106	23	262	5	474	E-ECU-029	INTAKE AIR PRESS. SENSOR FAULT	1. Intake manifold pressure sensor signal drift fault.	O									
P0107	23	263	20	472	E-ECU-030	INTAKE AIR PRESS. SENSOR SC2G FAULT	1. Intake manifold pressure sensor plausibility fault.	O									
P0108	24	264	18	471	E-ECU-031	INTAKE AIR PRESS. SENSOR OC OR SC2VBATT FAULT	1. Intake manifold pressure sensor signal high or short to battery fault.	O									
P0112	23	274	20	488	E-ECU-032	INLET AIR TEMP. SENSOR SC2G FAULT	1. Inlet air temperature (MAF) sensor signal is low or electrical low.										
P0113	24	275	18	487	E-ECU-033	INLET AIR TEMP. SENSOR OC OR SC2VBATT HIGH FAULT	1. Inlet air temperature (MAF) sensor signal is high or electrical high.										
P0115	00	277	1	454	E-ECU-034	COOLANT TEMP. SENSOR PLAUSIBILITY	1. Coolant temp. sensor plausibility fault.	O									
P0117	23	279	20	456	E-ECU-035	COOLANT TEMP. SENSOR SC2G FAULT	1. Coolant temp. sensor signal low fault.										
P0118	24	280	18	455	E-ECU-036	COOLANT TEMP. SENSOR OC OR SC2VBATT FAULT	1. Coolant temp. sensor signal high fault.										
P0120	00	288	23	431	E-ECU-037	FOOT PEDAL SIGNAL TRACK1 FAULT	1. Foot pedal signal track 1 fault.	O									
P0182	23	386	20	452	E-ECU-038	FUEL TEMP. SENSOR SC2G FAULT	1. Fuel temperature sensor low fault.										
P0183	24	387	18	451	E-ECU-039	FUEL TEMP. SENSOR OC OR SC2VBATT FAULT	1. Fuel temperature sensor high fault.	O									
P0190	27	400	22	323	E-ECU-040	RAIL PRESSURE SENSOR SIGNAL GRADIENT FAULT	1. Rail pressure sensor signal gradient fault.	O	O								
P0191	0	401	1	321	E-ECU-041	RAIL PRESSURE SENSOR PLAUSIBILITY FAULT	1. Rail Pressure Sensor electrical fault. 2. Rail Pressure Sensor plausibility fault: too high, too low, sensor drift too big"	O	O								
P0191	23	401	6	331	E-ECU-042	RAIL PRESSURE SENSOR PLAUSIBILITY FAULT	1. Rail Pressure Sensor electrical fault. 2. Rail Pressure Sensor plausibility fault: too high, too low, sensor drift too big"	O	O								
P0191	23	401	5	332	E-ECU-043	RAIL PRESSURE SENSOR PLAUSIBILITY FAULT	1. Rail Pressure Sensor electrical fault. 2. Rail Pressure Sensor plausibility fault: too high, too low, sensor drift too big"	O	O	O							
P0191	24	401	30	333	E-ECU-044	RAIL PRESSURE SENSOR PLAUSIBILITY FAULT	1. Rail Pressure Sensor electrical fault. 2. Rail Pressure Sensor plausibility fault: too high, too low, sensor drift too big"	O	O	O							
P0192	23	402	20	325	E-ECU-045	RAIL PRESSURE SENSOR SIGNAL SC2G FAULT	1. Rail pressure sensor signal low fault.	O	O								
P0193	27	403	18	324	E-ECU-046	RAIL PRESSURE SENSOR SIGNAL OC OR SC2VATT FAULT	1. Rail pressure sensor signal high fault.	O	O								
P0201	13	513	18	151	E-ECU-047	INJECTOR 0 OPEN CIRCUIT FAULT	1. Injector 0 short circuit to HSD to LSD. 2. Injector 0 open circuit fault. * 4CYL Engine: Cylinder No.1// 3CYL Engine: Cylinder No.1	O									
P0201	01	513	19	161	E-ECU-048	INJECTOR 0 SHORT CIRCUIT FAULT	1. Injector 0 short circuit to HSD to LSD. 2. Injector 0 open circuit fault. * 4CYL Engine: Cylinder No.1// 3CYL Engine: Cylinder No.1	O									
P0202	13	514	18	154	E-ECU-049	INJECTOR 3 OPEN CIRCUIT FAULT	1. Injector 3 short circuit to HSD to LSD. 2. Injector 3 open circuit fault. * 4CYL Engine: Cylinder No.2	O									
P0202	01	514	19	164	E-ECU-050	INJECTOR 3 SHORT CIRCUIT FAULT	1. Injector 3 short circuit to HSD to LSD. 2. Injector 3 open circuit fault. * 4CYL Engine: Cylinder No.2	O									
P0203	13	515	18	152	E-ECU-051	INJECTOR 1 OPEN CIRCUIT FAULT	1. Injector 1 short circuit to HSD to LSD. 2. Injector 1 open circuit fault. * 4CYL Engine: Cylinder No.3	O									
P0203	01	515	19	162	E-ECU-052	INJECTOR 1 SHORT CIRCUIT FAULT	1. Injector 1 short circuit to HSD to LSD. 2. Injector 1 open circuit fault. * 4CYL Engine: Cylinder No.3	O									

ENGINE - DIAGNOSIS

FAULT CODE					CLUSTER CODE	FAULT NAME	DESCRIPTION	ACTION							EGR Inducement		
DTC CODE		J1939		LAMP CODE				CEL"ON"	DELAYED ENGINE STOP (20s)	CCRT (DPF) REGEN DISABLE OR STOP	INCRE-ASED IDLE (1300 rpm)	DISABLE EACH INJECTOR	LIMP HOME (1400 rpm)	TORQUE REDUCTION (2200 rpm)	EMISSION FAILURE LAMP "ON"	SPEED REDUCTION Warn : N/A Low Level: N/A Severe Level : 60%	TORQUE REDUCTION Warn : N/A Low Level: 25% Severe Level : 50%
HMB	LB	SPN	FMI														
P0204	13	516	18	153	E-ECU-053	INJECTOR 2 OPEN CIRCUIT FAULT	1. Injector 2 short circuit to HSD to LSD. 2. Injector 2 open circuit fault. * 4CYL Engine: Cylinder No.4// 3CYL Engine: Cylinder No.3	O									
P0204	01	516	19	163	E-ECU-054	INJECTOR 2 SHORT CIRCUIT FAULT	1. Injector 2 short circuit to HSD to LSD. 2. Injector 2 open circuit fault. * 4CYL Engine: Cylinder No.4// 3CYL Engine: Cylinder No.3	O									
P0220	00	544	24	432	E-ECU-055	FOOT PEDAL SIGNAL TRACK 2 FAULT	1. Foot pedal signal track 2 fault.	O									
P0252	00	594	7	211	E-ECU-056	RAIL PRESSURE CONTORL FAULT	1. Rail pressure control error . (The duty cycle applied to the inlet metering valve is clamped by an upper value).	O									
P0261	1A	609	14	741	E-ECU-057	INJECTOR 0 & WIRING LSD RESISTANCE FAULT	1. Injector 0 & wiring low side resistance drop. 2. Injector 0 & wiring low side resistance level too high or low. * 4CYL Engine: Cylinder No.1// 3CYL Engine: Cylinder No.1	O									
P0261	1A	609	14	745		INJECTOR 0 & WIRING LSD RESISTANCE FAULT	1. Injector 0 & wiring low side resistance drop. 2. Injector 0 & wiring low side resistance level too high or low. * 4CYL Engine: Cylinder No.1// 3CYL Engine: Cylinder No.1	O									
P0262	1B	610	15	731	E-ECU-058	INJECTOR 0 & WIRING HSD RESISTANCE FAULT	1. Injector 0 & wiring high side resistance drop. 2. Injector 0 & wiring high side resistance level too high or low. * 4CYL Engine: Cylinder No.1// 3CYL Engine: Cylinder No.1	O									
P0262	1B	610	15	735		INJECTOR 0 & WIRING HSD RESISTANCE FAULT	1. Injector 0 & wiring high side resistance drop. 2. Injector 0 & wiring high side resistance level too high or low. * 4CYL Engine: Cylinder No.1// 3CYL Engine: Cylinder No.1	O									
P0264	1A	612	14	744	E-ECU-059	INJECTOR 3 & WIRING LSD RESISTANCE FAULT	1. Injector 3 & wiring low side resistance drop. 2. Injector 3 & wiring low side resistance level too high or low. * 4CYL Engine: Cylinder No.2	O									
P0264	1A	612	14	748		INJECTOR 3 & WIRING LSD RESISTANCE FAULT	1. Injector 3 & wiring low side resistance drop. 2. Injector 3 & wiring low side resistance level too high or low. * 4CYL Engine: Cylinder No.2	O									
P0265	1B	613	15	734	E-ECU-060	INJECTOR 3 & WIRING HSD RESISTANCE FAULT	1. Injector 3 & wiring high side resistance drop. 2. Injector 3 & wiring high side resistance level too high or low. * 4CYL Engine: Cylinder No.2	O									
P0265	1B	613	15	738		INJECTOR 3 & WIRING HSD RESISTANCE FAULT	1. Injector 3 & wiring high side resistance drop. 2. Injector 3 & wiring high side resistance level too high or low. * 4CYL Engine: Cylinder No.2	O									
P0267	1A	615	14	742	E-ECU-061	INJECTOR 1 & WIRING LSD RESISTANCE FAULT	1. Injector 1 & wiring low side resistance drop. 2. Injector 1 & wiring low side resistance level too high or low. * 4CYL Engine: Cylinder No.3// 3CYL Engine: Cylinder No.2	O									
P0267	1A	615	14	746		INJECTOR 1 & WIRING LSD RESISTANCE FAULT	1. Injector 1 & wiring low side resistance drop. 2. Injector 1 & wiring low side resistance level too high or low. * 4CYL Engine: Cylinder No.3// 3CYL Engine: Cylinder No.2	O									
P0268	1B	616	15	732	E-ECU-062	INJECTOR 1 & WIRING HSD RESISTANCE FAULT	1. Injector 1 & wiring high side resistance drop. 2. Injector 1 & wiring high side resistance level too high or low. * 4CYL Engine: Cylinder No.3// 3CYL Engine: Cylinder No.2	O									
P0268	1B	616	15	736		INJECTOR 1 & WIRING HSD RESISTANCE FAULT	1. Injector 1 & wiring high side resistance drop. 2. Injector 1 & wiring high side resistance level too high or low. * 4CYL Engine: Cylinder No.3// 3CYL Engine: Cylinder No.2	O									
P0270	1A	624	14	743	E-ECU-063	INJECTOR 2 & WIRING LSD RESISTANCE FAULT	1. Injector 2 & wiring low side resistance drop. 2. Injector 2 & wiring low side resistance level too high or low. * 4CYL Engine: Cylinder No.4// 3CYL Engine: Cylinder No.3	O									
P0270	1A	624	14	747		INJECTOR 2 & WIRING LSD RESISTANCE FAULT	1. Injector 2 & wiring low side resistance drop. 2. Injector 2 & wiring low side resistance level too high or low. * 4CYL Engine: Cylinder No.4// 3CYL Engine: Cylinder No.3	O									

ENGINE - DIAGNOSIS

FAULT CODE					CLUSTER CODE	FAULT NAME	DESCRIPTION	ACTION							EGR Inducement			
DTC CODE		J1939		LAMP CODE				CEL "ON"	DELAYED ENGINE STOP (20s)	CCRT (DPF) REGEN DISABLE OR STOP	INCRE-ASED IDLE (1300 rpm)	DISABLE EACH INJECTOR	LIMP HOME (1400 rpm)	TORQUE REDUCTION (2200 rpm)	EMISSION FAILURE LAMP "ON"	SPEED REDUCTION Warn : N/A Low Level: N/A Severe Level : 60%	TORQUE REDUCTION Warn : N/A Low Level: 25% Severe Level : 50%	
HMB	LB	SPN	FMI															
P0271	1B	625	15	733	E-ECU-064	INJECTOR 2 & WIRING HSD RESISTANCE FAULT	1. Injector 2 & wiring high side resistance drop. 2. Injector 2 & wiring high side resistance level too high or low. * 4CYL Engine: Cylinder No.4// 3CYL Engine: Cylinder No.3	O										
P0271	1B	625	15	737		INJECTOR 2 & WIRING HSD RESISTANCE FAULT	1. Injector 2 & wiring high side resistance drop. 2. Injector 2 & wiring high side resistance level too high or low. * 4CYL Engine: Cylinder No.4// 3CYL Engine: Cylinder No.3	O										
P029A	00	666	6	171	E-ECU-065	INJECTOR 0 MDP TRIM HIGH FAULT	1. Injector 0 MDP trim high fault. 2. Injector 0 MDP trim exceeds the maximum calibrated threshold limit. * 4CYL Engine: Cylinder No.1// 3CYL Engine: Cylinder No.1	O			O							
P029A	00	666	6	171		INJECTOR 0 MDP TRIM HIGH FAULT	1. Injector 0 MDP trim high fault. 2. Injector 0 MDP trim exceeds the maximum calibrated threshold limit. * 4CYL Engine: Cylinder No.1// 3CYL Engine: Cylinder No.1	O				O						
P029A	00	666	6	171		INJECTOR 0 MDP TRIM HIGH FAULT	1. Injector 0 MDP trim high fault. 2. Injector 0 MDP trim exceeds the maximum calibrated threshold limit. * 4CYL Engine: Cylinder No.1// 3CYL Engine: Cylinder No.1	O				O						
P029B	00	667	30	171	E-ECU-066	INJECTOR 0 LEARNING FAULT	1. Injector 0 absolute MDP value is below a calibrated threshold. 2. Injector 0 MDP trim low fault. * 4CYL Engine: Cylinder No.1// 3CYL Engine: Cylinder No.1	O				O						
P029B	00	667	5	171	E-ECU-067	INJECTOR 0 LEARNING FAULT	1. Injector 0 absolute MDP value is below a calibrated threshold. 2. Injector 0 MDP trim low fault. * 4CYL Engine: Cylinder No.1// 3CYL Engine: Cylinder No.1	O										
P029B	00	667	5	171		INJECTOR 0 LEARNING FAULT	1. Injector 0 absolute MDP value is below a calibrated threshold. 2. Injector 0 MDP trim low fault. * 4CYL Engine: Cylinder No.1// 3CYL Engine: Cylinder No.1	O										
P029B	00	667	5	171		INJECTOR 0 LEARNING FAULT	1. Injector 0 absolute MDP value is below a calibrated threshold. 2. Injector 0 MDP trim low fault. * 4CYL Engine: Cylinder No.1// 3CYL Engine: Cylinder No.1	O										
P029E	00	670	6	174	E-ECU-068	INJECTOR 3 MDP TRIM HIGH FAULT	1. Injector 2 MDP trim high fault. 2. Injector 2 MDP trim exceeds the maximum calibrated threshold limit. * 4CYL Engine: Cylinder No.4// 3CYL Engine: Cylinder No.3	O				O						
P029E	00	670	6	174		INJECTOR 3 MDP TRIM HIGH FAULT	1. Injector 2 MDP trim high fault. 2. Injector 2 MDP trim exceeds the maximum calibrated threshold limit. * 4CYL Engine: Cylinder No.4// 3CYL Engine: Cylinder No.3	O				O						
P029E	00	670	6	174		INJECTOR 3 MDP TRIM HIGH FAULT	1. Injector 2 MDP trim high fault. 2. Injector 2 MDP trim exceeds the maximum calibrated threshold limit. * 4CYL Engine: Cylinder No.4// 3CYL Engine: Cylinder No.3	O				O						
P029F	00	671	30	174	E-ECU-069	INJECTOR 3 LEARNING FAULT	1. Injector 2 absolute MDP value is below a calibrated threshold. 2. Injector 2 MDP trim low fault. * 4CYL Engine: Cylinder No.4// 3CYL Engine: Cylinder No.3	O				O						
P029F	00	671	5	174	E-ECU-070	INJECTOR 3 LEARNING FAULT	1. Injector 2 absolute MDP value is below a calibrated threshold. 2. Injector 2 MDP trim low fault. * 4CYL Engine: Cylinder No.4// 3CYL Engine: Cylinder No.3	O										
P029F	00	671	5	174		INJECTOR 3 LEARNING FAULT	1. Injector 2 absolute MDP value is below a calibrated threshold. 2. Injector 2 MDP trim low fault. * 4CYL Engine: Cylinder No.4// 3CYL Engine: Cylinder No.3	O										
P029F	00	671	5	174		INJECTOR 3 LEARNING FAULT	1. Injector 2 absolute MDP value is below a calibrated threshold. 2. Injector 2 MDP trim low fault. * 4CYL Engine: Cylinder No.4// 3CYL Engine: Cylinder No.3	O										

ENGINE - DIAGNOSIS

FAULT CODE					CLUSTER CODE	FAULT NAME	DESCRIPTION	ACTION							EGR Inducement		
DTC CODE		J1939		LAMP CODE				CEL"ON"	DELAYED ENGINE STOP (20s)	CCRT (DPF) REGEN DISABLE OR STOP	INCRE-ASED IDLE (1300 rpm)	DISABLE EACH INJECTOR	LIMP HOME (1400 rpm)	TORQUE REDUCTION (2200 rpm)	EMISSION FAILURE LAMP "ON"	SPEED REDUCTION Warn : N/A Low Level: N/A Severe Level : 60%	TORQUE REDUCTION Warn : N/A Low Level: 25% Severe Level : 50%
HMB	LB	SPN	FMI														
P02A2	00	674	6	172	E-ECU-071	INJECTOR 1 MDP TRIM HIGH FAULT	1. Injector 1 MDP trim high fault. 2. Injector 1 MDP trim exceeds the maximum calibrated threshold limit. * 4CYL Engine: Cylinder No.3// 3CYL Engine: Cylinder No.2	O									
P02A2	00	674	6	172		INJECTOR 1 MDP TRIM HIGH FAULT	1. Injector 1 MDP trim high fault. 2. Injector 1 MDP trim exceeds the maximum calibrated threshold limit. * 4CYL Engine: Cylinder No.3// 3CYL Engine: Cylinder No.2	O									
P02A2	00	674	6	172		INJECTOR 1 MDP TRIM HIGH FAULT	1. Injector 1 MDP trim high fault. 2. Injector 1 MDP trim exceeds the maximum calibrated threshold limit. * 4CYL Engine: Cylinder No.3// 3CYL Engine: Cylinder No.2	O									
P02A3	00	675	30	172	E-ECU-072	INJECTOR 1 LEARNING FAULT	1. Injector 2 absolute MDP value is below a calibrated threshold. 2. Injector 2 MDP trim low fault. * 4CYL Engine: Cylinder No.4// 3CYL Engine: Cylinder No.3	O									
P02A3	00	675	5	172	E-ECU-073	INJECTOR 1 LEARNING FAULT	1. Injector 2 absolute MDP value is below a calibrated threshold. 2. Injector 2 MDP trim low fault. * 4CYL Engine: Cylinder No.4// 3CYL Engine: Cylinder No.3	O									
P02A3	00	675	5	172		INJECTOR 1 LEARNING FAULT	1. Injector 2 absolute MDP value is below a calibrated threshold. 2. Injector 2 MDP trim low fault. * 4CYL Engine: Cylinder No.4// 3CYL Engine: Cylinder No.3	O									
P02A3	00	675	5	172		INJECTOR 1 LEARNING FAULT	1. Injector 2 absolute MDP value is below a calibrated threshold. 2. Injector 2 MDP trim low fault. * 4CYL Engine: Cylinder No.4// 3CYL Engine: Cylinder No.3	O									
P02A6	00	678	6	173	E-ECU-074	INJECTOR 2 MDP TRIM HIGH FAULT	1. Injector 3 MDP trim high fault. 2. Injector 3 MDP trim exceeds the maximum calibrated threshold limit. * 4CYL Engine: Cylinder No.2	O									
P02A6	00	678	6	173		INJECTOR 2 MDP TRIM HIGH FAULT	1. Injector 3 MDP trim high fault. 2. Injector 3 MDP trim exceeds the maximum calibrated threshold limit. * 4CYL Engine: Cylinder No.2	O									
P02A6	00	678	6	173		INJECTOR 2 MDP TRIM HIGH FAULT	1. Injector 3 MDP trim high fault. 2. Injector 3 MDP trim exceeds the maximum calibrated threshold limit. * 4CYL Engine: Cylinder No.2	O									
P02A7	00	679	30	173	E-ECU-075	INJECTOR 2 LEARNING FAULT	1. Injector 3 absolute MDP value is below a calibrated threshold. 2. Injector 3 MDP trim low fault. * 4CYL Engine: Cylinder No.2	O									
P02A7	00	679	5	173	E-ECU-076	INJECTOR 2 LEARNING FAULT	1. Injector 3 absolute MDP value is below a calibrated threshold. 2. Injector 3 MDP trim low fault. * 4CYL Engine: Cylinder No.2	O									
P02A7	00	679	5	173		INJECTOR 2 LEARNING FAULT	1. Injector 3 absolute MDP value is below a calibrated threshold. 2. Injector 3 MDP trim low fault. * 4CYL Engine: Cylinder No.2	O									
P02A7	00	679	5	173		INJECTOR 2 LEARNING FAULT	1. Injector 3 absolute MDP value is below a calibrated threshold. 2. Injector 3 MDP trim low fault. * 4CYL Engine: Cylinder No.2	O									
P0325	00	805	1	121	E-ECU-077	KNOCK SENSOR 1 FAULT	1. Knock sensor 1 signal or noise ratio is too low in idle.	O									
P0330	00	816	1	122	E-ECU-078	KNOCK SENSOR 2 FAULT	1. Knock sensor 2 signal or noise ratio is too low in idle.	O									
P0335	85	821	27	424	E-ECU-079	CRANK SENSOR SIGNAL OVER SPEED FAULT	1. Crank signal over speed fault. 2. Crank signal gap lost fault.	O									
P0335	31	821	2	425	E-ECU-080	CRANK SENSOR SIGNAL GAP MISSED FAULT	1. Crank signal over speed fault. 2. Crank signal gap lost fault.	O									
P0340	54	832	30	415	E-ECU-081	CAM SENSOR SIGNAL LEARNING FAULT	1. Cam signal learning fault. 2. Cam signal erratic fault.	O									
P0340	2F	832	29	414	E-ECU-082	CAM SENSOR SIGNAL ERRATIC FAULT	1. Cam signal learning fault. 2. Cam signal erratic fault.	O									



ENGINE - DIAGNOSIS

FAULT CODE						FAULT NAME	DESCRIPTION	ACTION							EGR Inducement		
DTC CODE		J1939		LAMP CODE	CLUSTER CODE			CEL "ON"	DELAYED ENGINE STOP (20s)	CCRT (DPF) REGEN DISABLE OR STOP	INCRE-ASED IDLE (1300 rpm)	DISABLE EACH INJECTOR	LIMP HOME (1400 rpm)	TORQUE REDUCTION (2200 rpm)	EMISSION FAILURE LAMP "ON"	SPEED REDUCTION Warn : N/A Low Level: N/A Severe Level: 60%	TORQUE REDUCTION Warn : N/A Low Level: 25% Severe Level: 50%
HMB	LB	SPN	FMI														
P0341	31	833	26	411	E-ECU-083	CAM SENSOR SIGNAL FAULT	1. Cam signal drift high. 2. Cam signal lost. 3. Cam signal missing.	○					○				
P0341	00	833	30	413	E-ECU-084	CAM SENSOR SIGNAL DRIFT FAULT	1. Cam signal drift high. 2. Cam signal lost. 3. Cam signal missing.	○					○				
P0341	31	833	29	412	E-ECU-085	CAM SENSOR SIGNAL FAULT	1. Cam signal drift high. 2. Cam signal lost. 3. Cam signal missing.	○					○				
P0371	00	881	27	423	E-ECU-086	CRANK SIGNAL FAULT 2	1. Crank signal is too close to the previous one.	○					○				
P0372	31	882	23	422	E-ECU-087	CRANK SIGNAL FAULT 3	1. Crankshaft signal missing fault.	○					○				
P0374	31	884	26	421	E-ECU-088	CRANK SIGNAL FAULT 4	1. Crank signal lost fault.	○					○				
P0380	11	896	20	753	E-ECU-089	GLOW PLUG RELAY SC2G FAULT	1. Glow plug relay fault. 2. Glow plug relay open circuit.										
P0380	12	896	21	754	E-ECU-090	GLOW PLUG RELAY SC2VBATT FAULT	1. Glow plug relay fault. 2. Glow plug relay open circuit.										
P0380	00	896	30	751	E-ECU-091	GLOW PLUG RELAY FAULT	1. Glow plug relay fault. 2. Glow plug relay open circuit.										
P0380	13	896	18	752	E-ECU-092	GLOW PLUG RELAY OC FAULT	1. Glow plug relay fault. 2. Glow plug relay open circuit.										
P0381	11	897	20	636	E-ECU-093	GLOW PLUG LAMP SC2G FAULT	1. Glow plug lamp driver open circuit fault.										
P0381	12	897	21	637	E-ECU-094	GLOW PLUG LAMP SC2VBATT FAULT	1. Glow plug lamp driver open circuit fault.										
P0381	13	897	18	635	E-ECU-095	GLOW PLUG LAMP OC FAULT	1. Glow plug lamp driver open circuit fault.										
P0400	23	1024	5	518	E-ECU-096	EGR CONTROL AIR FLOW LOW FAULT	1. EGR control airflow low fault.						○	○	○		
P0401	24	1025	6	517	E-ECU-097	EGR CONTROL AIR FLOW HIGH FAULT	1. EGR control airflow high fault.						○	○	○		
P0403	00	1027	1	514	E-ECU-098	EGR CONTROL AND SINAL FAULT	1. EGR position control fault. 2. EGR H-bridge driver open circuit (OC). 3. EGR H-bridge driver short circuit to ground (SC2G). 4. EGR H-bridge driver short circuit to battery voltage (SC2VBAT).	○		○			○ (1500rpm)	○	○	○	
P0403	11	1027	20	522	E-ECU-099	EGR SC2G FAULT	1. EGR position control fault. 2. EGR H-bridge driver open circuit (OC). 3. EGR H-bridge driver short circuit to ground (SC2G). 4. EGR H-bridge driver short circuit to battery voltage (SC2VBAT).	○		○			○ (1500rpm)	○	○	○	
P0403	12	1027	21	523	E-ECU-100	EGR SC2VBATT FAULT	1. EGR position control fault. 2. EGR H-bridge driver open circuit (OC). 3. EGR H-bridge driver short circuit to ground (SC2G). 4. EGR H-bridge driver short circuit to battery voltage (SC2VBAT).	○		○			○ (1500rpm)	○	○	○	
P0403	04	1027	3	526	E-ECU-101	EGR H-BRIDGE DRIVER FAULT	1. EGR position control fault. 2. EGR H-bridge driver open circuit (OC). 3. EGR H-bridge driver short circuit to ground (SC2G). 4. EGR H-bridge driver short circuit to battery voltage (SC2VBAT).	○		○			○ (1500rpm)	○	○	○	
P0403	04	1027	3	527		EGR H-BRIDGE DRIVER FAULT	1. EGR position control fault. 2. EGR H-bridge driver open circuit (OC). 3. EGR H-bridge driver short circuit to ground (SC2G). 4. EGR H-bridge driver short circuit to battery voltage (SC2VBAT).	○		○			○ (1500rpm)	○	○	○	
P0403	04	1027	4	525	E-ECU-102	EGR H-BRIDGE DRIVER FAULT	1. EGR position control fault. 2. EGR H-bridge driver open circuit (OC). 3. EGR H-bridge driver short circuit to ground (SC2G). 4. EGR H-bridge driver short circuit to battery voltage (SC2VBAT).	○		○			○ (1500rpm)	○	○	○	

ENGINE - DIAGNOSIS

FAULT CODE					FAULT NAME	DESCRIPTION	ACTION							EGR Inducement			
DTC CODE		J1939		LAMP CODE			CLUSTER CODE	CEL"ON"	DELAYED ENGINE STOP (20s)	CCRT (DPF) REGEN DISABLE OR STOP	INCRE-ASED IDLE (1300 rpm)	DISABLE EACH INJECTOR	LIMP HOME (1400 rpm)	TORQUE REDUCTION (2200 rpm)	EMISSION FAILURE LAMP "ON"	SPEED REDUCTION Warn : N/A Low Level: N/A Severe Level : 60%	TORQUE REDUCTION Warn : N/A Low Level: 25% Severe Level : 50%
HMB	LB	SPN	FMI														
P0403	13	1027	18	521	E-ECU-103	EGR H-BRIDGE DRIVER FAULT	1. EGR position control fault. 2. EGR H-bridge driver open circuit (OC). 3. EGR H-bridge driver short circuit to ground (SC2G). 4. EGR H-bridge driver short circuit to battery voltage (SC2VBAT).	0		0				0 (1500rpm)	0	0	0
P0403	04	1027	2	524	E-ECU-104	EGR H-BRIDGE DRIVER FAULT	1. EGR position control fault. 2. EGR H-bridge driver open circuit (OC). 3. EGR H-bridge driver short circuit to ground (SC2G). 4. EGR H-bridge driver short circuit to battery voltage (SC2VBAT).	0		0				0 (1500rpm)	0	0	0
P0404	00	1028	30	515	E-ECU-105	EGR POSITION LEARNING DRIFT FAULT	1. EGR position learning drift fault.	0		0				0 (1500rpm)	0	0	0
P0405	23	1029	20	512	E-ECU-106	EGR POSITION FEEDBACK SIGNAL SC2G FAULT	1. EGR position feedback signal low fault.							0 (1500rpm)	0	0	0
P0406	24	1030	21	511	E-ECU-107	EGR POSITION FEEDBACK SIGNAL OC OR SC2VBATT FAULT	1. EGR position feedback signal high fault.							0 (1500rpm)	0	0	0
P0487	54	1159	30	551	E-ECU-108	ACV POSITION LEARNING FAULT	1. Throttle position feedback signal low or high fault. 2. Throttle learning position fault.	0		0							
P0487	54	1159	30	552		ACV POSITION LEARNING FAULT	1. Throttle position feedback signal low or high fault. 2. Throttle learning position fault.	0		0							
P0487	23	1159	20	532	E-ECU-109	ACV POSITION FEEDBACK SIGNAL SC2G FAULT	1. Throttle position feedback signal low or high fault. 2. Throttle learning position fault.	0		0							
P0487	24	1159	18	531	E-ECU-110	ACV POSITION FEEDBACK SIGNAL OC OR SC2VBATT FAULT	1. Throttle position feedback signal low or high fault. 2. Throttle learning position fault.	0		0							
P049D	00	1181	30	516	E-ECU-111	EGR POSITION LEARNING RANGE FAULT	1. EGR position learning range fault.	0		0				0 (1500rpm)	0	0	0
P0522	23	1314	5	658	E-ECU-112	ENGINE OIL PRESSURE LOW FAULT	1. At engine run, oil pressure remains low.	0				0					
P0544	00	1348	1	465	E-ECU-113	EXHAUST GAS TEMP.SENSOR FAULT	1. Exhaust manifold sensor fault.	0									
P0545	00	1349	20	467	E-ECU-114	EXHAUST GAS TEMP.SENSOR SC2G FAULT	1. Exhaust manifold temperature sensor circuit low.	0									
P0546	00	1350	18	466	E-ECU-115	EXHAUST GAS TEMP.SENSOR OC OR SC2VBATT FAULT	1. Exhaust manifold Temperature Sensor Circuit High.	0									
P0562	23	1378	4	712	E-ECU-116	BATTERY VOLTAGE LOW FAULT	1. Battery voltage low fault.										
P0563	24	1379	4	711	E-ECU-117	BATTERY VOLTAGE HIGH FAULT	1. Battery voltage high fault.	0						0			
P0602	00	1538	26	115	E-ECU-118	INJECTOR C3I RAM DATA FAULT	1. C2I data not programmed. 2. Multiple calibration faults - Non Volatile Memory fault.	0				0		0			
P0602	F3	1538	13	114	E-ECU-119	INJECTOR 3 C3I DATA FAULT	1. C2I data not programmed. 2. Multiple calibration faults - Non Volatile Memory fault.	0				0		0			
P0602	F2	1538	12	113	E-ECU-120	INJECTOR 2 C3I DATA FAULT	1. C2I data not programmed. 2. Multiple calibration faults - Non Volatile Memory fault.	0				0		0			
P0602	F1	1538	11	112	E-ECU-121	INJECTOR 1 C3I DATA FAULT	1. C2I data not programmed. 2. Multiple calibration faults - Non Volatile Memory fault.	0				0		0			
P0602	F0	1538	10	111	E-ECU-122	INJECTOR 0 C3I DATA FAULT	1. C2I data not programmed. 2. Multiple calibration faults - Non Volatile Memory fault.	0				0		0			
P0603	00	1539	26	815	E-ECU-123	ECU MEMORY INTEGRITY DATA FAULT	1. ECU memory integrity fault (data / cal integrity).	0									
P0604	00	1540	26	816	E-ECU-124	ECU MEMORY INTEGRITY RAM FAULT	1. ECU memory integrity fault (RAM integrity). 2. Internal control module random access memory (RAM) error.	0									
P0605	00	1541	26	814	E-ECU-125	ECU MEMORY INTEGRITY FAULT	1. ECU memory integrity fault (code integrity). 2. Internal control module read only memory (ROM) error.	0									
P060B	00	1547	26	811	E-ECU-126	ECU ADC FAULT	1. Internal control module A/D convertor processing performance error.	0				0		0			
P061B	00	1563	26	831	E-ECU-127	ESM 0 TORQUE MONITORING	1. ESM 0 Torque Monitoring Fault.	0									

**ENGINE - DIAGNOSIS**

FAULT CODE						FAULT NAME	DESCRIPTION	ACTION							EGR Inducement		
DTC CODE		J1939		LAMP CODE	CLUSTER CODE			CEL "ON"	DELAYED ENGINE STOP (20s)	CCRT (DPF) REGEN DISABLE OR STOP	INCRE-ASED IDLE (1300 rpm)	DISABLE EACH INJECTOR	LIMP HOME (1400 rpm)	TORQUE REDUCTION (2200 rpm)	EMISSION FAILURE LAMP "ON"	SPEED REDUCTION Warn : N/A Low Level: N/A Severe Level : 60%	TORQUE REDUCTION Warn : N/A Low Level: 25% Severe Level : 50%
HMB	LB	SPN	FMI														
P062D	11	1581	20	131	E-ECU-128	INJECTOR DRIVER CIRCUIT PERFORMANCE BANK 'A' FAULT	1. Injector bank A SC2G. 2. Injector bank A SC2V.	O				O	O				
P062D	12	1581	21	133	E-ECU-129	INJECTOR DRIVER CIRCUIT PERFORMANCE BANK 'A' FAULT	1. Injector bank A SC2G. 2. Injector bank A SC2V.	O				O	O				
P062D	04	1581	1	165	E-ECU-130	INJECTOR DRIVER CIRCUIT PERFORMANCE BANK 'A' FAULT	1. Injector bank A SC2G. 2. Injector bank A SC2V.	O			O	O					
P062E	11	1582	20	132	E-ECU-131	INJECTOR DRIVER CIRCUIT PERFORMANCE BANK 'B' FAULT	1. Injector bank B SC2V. 2. Injector bank B SC2G.	O				O	O				
P062E	12	1582	21	134	E-ECU-132	INJECTOR DRIVER CIRCUIT PERFORMANCE BANK 'B' FAULT	1. Injector bank B SC2V. 2. Injector bank B SC2G.	O				O	O				
P062E	04	1582	1	166	E-ECU-133	INJECTOR DRIVER CIRCUIT PERFORMANCE BANK 'B' FAULT	1. Injector bank B SC2V. 2. Injector bank B SC2G.	O			O	O					
P062F	00	1583	26	821	E-ECU-134	ECU DATA STORAGE FAULT	1. ECU non volatile memory fault (C3I, MDP, ICV, INJ, CNT, APP, FM, CAN). 2. Internal control module EEPROM error.	O				O					
P0641	00	1601	26	721	E-ECU-135	ECU INTERNAL 5V SUPPLY 1 FAULT	1. ECU internal 5V supply 2 fault.	O		O		O					
P0641	4B	1601	26	722		ECU INTERNAL 5V SUPPLY 1 FAULT	1. ECU internal 5V supply 2 fault.	O		O		O					
P0651	00	1617	26	723	E-ECU-136	ECU INTERNAL 5V SUPPLY 2 FAULT	1. ECU internal 5V supply 2 fault.	O		O		O					
P0651	4B	1617	26	724		ECU INTERNAL 5V SUPPLY 2 FAULT	1. ECU internal 5V supply 2 fault.	O		O		O					
P0685	00	1669	26	713	E-ECU-137	MAIN ECU RELAY FAULT	1. Main ECU relay stuck. 2. Main relay unexpected high state.										
P0685	01	1669	26	713		MAIN ECU RELAY FAULT	1. Main ECU relay stuck. 2. Main relay unexpected high state.	O									
P0697	00	1687	26	725	E-ECU-138	ECU INTERNAL 5V AUXILLARY FAULT	1. ECU internal 5V supply to auxiliary fault.	O		O		O					
P0697	4B	1687	26	726		ECU INTERNAL 5V AUXILLARY FAULT	1. ECU internal 5V supply to auxiliary fault.	O		O		O					
P1001	00	4097	25	583	E-ECU-139	DPF REDUCED TORQUE FAULT	1. DPF filter overloaded and trigger reduced torque.	O		O		O					
P1219	00	4633	26	895	E-ECU-140	ESM VDG MONITORING FAULT	1. ESM VDG Monitoring Fault.	O									
P1221	00	4641	25	433	E-ECU-141	FOOT PEDAL LIMP HOME FAULT	1. Foot pedal signal fault set (triggers limp home mode). 2. Consider using manufacturer's specific code for these Foot Pedal Faults.	O			O						
P1224	00	4644	25	443	E-ECU-142	HAND PEDAL LIMP HOME FAULT	1. Hand pedal signal fault set (triggers limp home mode). 2. Consider using manufacturer's specific code for these hand pedal faults.	O			O						
P1226	00	4646	25	447	E-ECU-143	PEDAL LIMP HOME FAULT	1. Global pedal fault has triggered limp home mode. 2. Consider using manufacturer's specific code for these global pedal faults.	O			O						
P1227	00	4647	25	448	E-ECU-144	PEDAL REDUCED TORQUE FAULT	1. Global pedal fault has triggered reduced torque mode. 2. Consider using manufacturer's specific code for these global pedal faults.	O				O					
P126A	11	4714	20	643	E-ECU-145	WATER IN FUEL SENSOR LAMP FAULT	1. Water in fuel lamp driver global fault. 2. Water in fuel lamp driver short circuit to battery voltage (SC2VBAT). 3. Water in fuel lamp driver short circuit to ground (SC2G). 4. Water in fuel lamp driver open circuit (OC).	O									
P126A	12	4714	21	644	E-ECU-146	WATER IN FUEL SENSOR LAMP FAULT	1. Water in fuel lamp driver global fault. 2. Water in fuel lamp driver short circuit to battery voltage (SC2VBAT). 3. Water in fuel lamp driver short circuit to ground (SC2G). 4. Water in fuel lamp driver open circuit (OC).	O									
P126A	13	4714	18	642	E-ECU-147	WATER IN FUEL SENSOR LAMP FAULT	1. Water in fuel lamp driver global fault. 2. Water in fuel lamp driver short circuit to battery voltage (SC2VBAT). 3. Water in fuel lamp driver short circuit to ground (SC2G). 4. Water in fuel lamp driver open circuit (OC).	O									



ENGINE - DIAGNOSIS

FAULT CODE						FAULT NAME	DESCRIPTION	ACTION							EGR Inducement		
DTC CODE		J1939		LAMP CODE	CLUSTER CODE			CEL"ON"	DELAYED ENGINE STOP (20s)	CCRT (DPF) REGEN DISABLE OR STOP	INCRE-ASED IDLE (1300 rpm)	DISABLE EACH INJECTOR	LIMP HOME (1400 rpm)	TORQUE REDUCTION (2200 rpm)	EMISSION FAILURE LAMP "ON"	SPEED REDUCTION Warn : N/A Low Level: N/A Severe Level : 60%	TORQUE REDUCTION Warn : N/A Low Level: 25% Severe Level : 50%
HMB	LB	SPN	FMI														
P126A	00	4714	30	641	E-ECU-148	WATER IN FUEL SENSOR LAMP FAULT	1. Water in fuel lamp driver global fault. 2. Water in fuel lamp driver short circuit to battery voltage (SC2VBAT). 3. Water in fuel lamp driver short circuit to ground (SC2G). 4. Water in fuel lamp driver open circuit (OC).										
P1303	00	4867	30	182	E-ECU-149	INJECTOR LEARNING CONDITION FAULT	1. Injector Learning Condition Fault.	O				O					
P1311	00	4881	30	182	E-ECU-150	INJECTOR LEARNING CONDITION FAULT	1. Injector Learning Condition Fault.	O				O					
P1600	11	5632	20	623	E-ECU-151	DPF REGENERATION WARNING LAMP SC2G FAULT	1. DPF regeneration warning lamp driver general fault. 2. DPF regeneration warning lamp driver SC2G (short circuit to ground). 3. DPF regeneration warning lamp driver SC2VBAT (short circuit to battery voltage). 4. DPF regeneration warning lamp driver OC (open circuit).	O									
P1600	12	5632	21	624	E-ECU-152	DPF REGENERATION WARNING LAMP SC2VBATT FAULT	1. DPF regeneration warning lamp driver general fault. 2. DPF regeneration warning lamp driver SC2G (short circuit to ground). 3. DPF regeneration warning lamp driver SC2VBAT (short circuit to battery voltage). 4. DPF regeneration warning lamp driver OC (open circuit).	O									
P1600	13	5632	18	622	E-ECU-153	DPF REGENERATION WARNING LAMP OC FAULT	1. DPF regeneration warning lamp driver general fault. 2. DPF regeneration warning lamp driver SC2G (short circuit to ground). 3. DPF regeneration warning lamp driver SC2VBAT (short circuit to battery voltage). 4. DPF regeneration warning lamp driver OC (open circuit).	O									
P1600	00	5632	30	621	E-ECU-154	DPF REGENERATION WARNING LAMP DRIVER FAULT	1. DPF regeneration warning lamp driver general fault. 2. DPF regeneration warning lamp driver SC2G (short circuit to ground). 3. DPF regeneration warning lamp driver SC2VBAT (short circuit to battery voltage). 4. DPF regeneration warning lamp driver OC (open circuit).										
P1601	03	5633	26	855	E-ECU-155	ESM LEVEL 3 FAULT	1. DPF regeneration underway lamp driver general fault. 2. DPF regeneration underway lamp driver SC2G (short circuit to ground). 3. DPF regeneration underway lamp driver SC2VBAT (short circuit to battery voltage). 4. DPF regeneration underway lamp driver OC (open circuit).	O									
P1601	11	5633	20	627	E-ECU-156	DPF REGENERATION UNDERWAY LAMP SC2G FAULT	1. DPF regeneration underway lamp driver general fault. 2. DPF regeneration underway lamp driver SC2G (short circuit to ground). 3. DPF regeneration underway lamp driver SC2VBAT (short circuit to battery voltage). 4. DPF regeneration underway lamp driver OC (open circuit).										
P1601	12	5633	21	628	E-ECU-157	DPF REGENERATION UNDERWAY LAMP SC2VBATT FAULT	1. DPF regeneration underway lamp driver general fault. 2. DPF regeneration underway lamp driver SC2G (short circuit to ground). 3. DPF regeneration underway lamp driver SC2VBAT (short circuit to battery voltage). 4. DPF regeneration underway lamp driver OC (open circuit).										
P1601	13	5633	18	626	E-ECU-158	DPF REGENERATION UNDERWAY LAMP OC FAULT	1. DPF regeneration underway lamp driver general fault. 2. DPF regeneration underway lamp driver SC2G (short circuit to ground). 3. DPF regeneration underway lamp driver SC2VBAT (short circuit to battery voltage). 4. DPF regeneration underway lamp driver OC (open circuit).										
P1601	00	5633	30	625	E-ECU-159	DPF REGENERATION UNDERWAY LAMP FAULT	1. DPF regeneration underway lamp driver general fault. 2. DPF regeneration underway lamp driver SC2G (short circuit to ground). 3. DPF regeneration underway lamp driver SC2VBAT (short circuit to battery voltage). 4. DPF regeneration underway lamp driver OC (open circuit).										
P1602	03	5634	26	854	E-ECU-160	ESM LEVEL 3 FAULT	1. ESM Level 3 Fault.	O									
P1604	03	5636	26	856	E-ECU-161	ESM LEVEL 3 FAULT	1. ESM Level 3 Fault.	O									
P1606	03	5638	26	834	E-ECU-162	ESM LEVEL 3 FAULT	1. ESM Level 3 Fault.	O									
P1606	03	5638	26	865		ESM LEVEL 3 FAULT	1. ESM Level 3 Fault.	O									
P1607	03	5639	26	835	E-ECU-163	ESM LEVEL 3 FAULT	1. ESM Level 3 Fault.	O									
P160B	03	5643	26	887	E-ECU-164	ESM LEVEL 3 FAULT	1. ESM Level 3 Fault.	O									
P160C	00	5644	26	842	E-ECU-165	ESM ENGINE OFF MONITORING FAULT	1. ESM Engine Off Monitoring Fault.	O									
P160D	00	5645	26	867	E-ECU-166	ESM PEDAL MONITORING FAULT	1. ESM Pedal Monitoring Fault.	O									
P160E	00	5646	26	866	E-ECU-167	ESM HAND PEDAL MONITORING FAULT	1. ESM Hand Pedal Monitoring Fault.	O									

SAFETY FIRST

ENGINE

DRIVING & CHASSIS

HYDRAULIC SYSTEM

ELECTRIC SYSTEM

CABIN

INDEX

ENGINE - DIAGNOSIS

FAULT CODE						FAULT NAME	DESCRIPTION	ACTION							EGR Inducement		
DTC CODE		J1939		LAMP CODE	CLUSTER CODE			CEL "ON"	DELAYED ENGINE STOP (20s)	CCRT (DPF) REGEN DISABLE OR STOP	INCRE-ASED IDLE (1300 rpm)	DISABLE EACH INJECTOR	LIMP HOME (1400 rpm)	TORQUE REDUCTION (2200 rpm)	EMISSION FAILURE LAMP "ON"	SPEED REDUCTION Warn : N/A Low Level: 60% Severe Level : 60%	TORQUE REDUCTION Warn : N/A Low Level: 25% Severe Level : 50%
HMB	LB	SPN	FMI														
P1611	03	5649	26	837	E-ECU-168	ESM LEVEL 3 FAULT	1. ESM Level 3 Fault.	O									
P1612	03	5650	26	846	E-ECU-169	ESM LEVEL 3 FAULT	1. ESM Level 3 Fault.	O									
P161B	00	5659	25	893	E-ECU-170	ESM TORQUE REDUCTION FAULT	1. ESM Torque reduction fault	O									
P1620	03	5664	26	859	E-ECU-171	ESM LEVEL 3 FAULT	1. ESM Level 3 Fault.	O									
P1621	03	5665	26	861	E-ECU-172	ESM LEVEL 3 FAULT	1. ESM Level 3 Fault.	O									
P1622	03	5666	26	862	E-ECU-173	ESM LEVEL 3 FAULT	1. ESM Level 3 Fault.	O									
P1623	03	5667	26	863	E-ECU-174	ESM LEVEL 3 FAULT	1. ESM Level 3 Fault.	O									
P1624	00	5668	26	864	E-ECU-175	ESM LEVEL 3 FAULT	1. ESM Level 3 Fault.	O									
P1625	03	5669	26	868	E-ECU-176	ESM LEVEL 3 FAULT	1. ESM Level 3 Fault.	O									
P1626	03	5670	26	869	E-ECU-177	ESM LEVEL 3 FAULT	1. ESM Level 3 Fault.	O									
P1627	03	5671	26	871	E-ECU-178	ESM LEVEL 3 FAULT	1. ESM Level 3 Fault.	O									
P1628	03	5672	26	872	E-ECU-179	ESM LEVEL 3 FAULT	1. ESM Level 3 Fault.	O									
P162B	03	5675	26	857	E-ECU-180	ESM LEVEL 3 FAULT	1. ESM Level 3 Fault.	O									
P1630	00	5680	26	873	E-ECU-181	ESM PULSE CHECK FAULT	1. ESM Pulse Check Fault.	O									
P1631	00	5681	26	874	E-ECU-182	ESM PULSE CHECK FAULT	1. ESM Pulse Check Fault.	O									
P1632	00	5682	26	875	E-ECU-183	ESM PULSE CHECK FAULT	1. ESM Pulse Check Fault.	O									
P1633	00	5683	26	876	E-ECU-184	ESM PULSE CHECK FAULT	1. ESM Pulse Check Fault.	O									
P1634	00	5684	26	877	E-ECU-185	ESM PULSE CHECK FAULT	1. ESM Pulse Check Fault.	O									
P1635	00	5685	26	878	E-ECU-186	ESM PULSE CHECK FAULT	1. ESM Pulse Check Fault.	O									
P1636	00	5686	26	879	E-ECU-187	ESM PULSE CHECK FAULT	1. ESM Pulse Check Fault.	O									
P1637	00	5687	26	881	E-ECU-188	ESM PULSE CHECK FAULT	1. ESM Pulse Check Fault.	O									
P1638	00	5688	26	882	E-ECU-189	ESM PULSE CHECK FAULT	1. ESM Pulse Check Fault.	O									
P1646	00	5702	1	661	E-ECU-190	PTO CRUISE SWITCH FAULT	1. PTO cruise inc/resume & dec/set switch frequency fault. 2. PTO cruise inc/resume & dec/set switch short circuit to ground (SC2G) fault.										
P1647	1	5703	1	662	E-ECU-191	PTO CRUISE DEC/SET SWITCH FAULT	1. PTO cruise DEC frequency fault. 2. PTO cruise DEC short circuit to ground (SC2G) fault.										
P1647	2	5703	22	663	E-ECU-192	PTO CRUISE DEC/SET SWITCH FAULT	1. PTO cruise DEC frequency fault. 2. PTO cruise DEC short circuit to ground (SC2G) fault.										
P1647	11	5703	20	664	E-ECU-193	PTO CRUISE DEC/SET SWITCH FAULT	1. PTO cruise DEC frequency fault. 2. PTO cruise DEC short circuit to ground (SC2G) fault.										
P1648	1	5704	1	665	E-ECU-194	PTO CRUISE INC/RESUME SWITCH FAULT	1. PTO cruise inc frequency fault. 2. PTO cruise inc short circuit to ground (SC2G) fault.										
P1648	2	5704	22	666	E-ECU-195	PTO CRUISE INC/RESUME SWITCH FAULT	1. PTO cruise inc frequency fault. 2. PTO cruise inc short circuit to ground (SC2G) fault.										
P1648	11	5704	20	667	E-ECU-196	PTO CRUISE INC/RESUME SWITCH FAULT	1. PTO cruise inc frequency fault. 2. PTO cruise inc short circuit to ground (SC2G) fault.										
P1650	11	5712	20	613	E-ECU-197	CHECK ENGINE LAMP SC2G FAULT	1. Check engine lamp driver general fault. 2. Check engine lamp driver SC2G (short circuit to ground) fault. 3. Check engine lamp driver SC2V (short circuit to battery voltage) fault. 4. Check engine lamp driver OC (open circuit) fault.										
P1650	12	5712	21	614	E-ECU-198	CHECK ENGINE LAMP SC2VBATT FAULT	1. Check engine lamp driver general fault. 2. Check engine lamp driver SC2G (short circuit to ground) fault. 3. Check engine lamp driver SC2V (short circuit to battery voltage) fault. 4. Check engine lamp driver OC (open circuit) fault.										

## ENGINE - DIAGNOSIS

FAULT CODE						FAULT NAME	DESCRIPTION	ACTION							EGR Inducement		
DTC CODE		J1939		LAMP CODE	CLUSTER CODE			CEL"ON"	DELAYED ENGINE STOP (20s)	CCRT (DPF) REGEN DISABLE OR STOP	INCRE-ASED IDLE (1300 rpm)	DISABLE EACH INJECTOR	LIMP HOME (1400 rpm)	TORQUE REDUCTION (2200 rpm)	EMISSION FAILURE LAMP "ON"	SPEED REDUCTION Warn : N/A Low Level: N/A Severe Level : 60%	TORQUE REDUCTION Warn : N/A Low Level: 25% Severe Level : 50%
HMB	LB	SPN	FMI														
P1650	00	5712	1	611	E-ECU-199	CHECK ENGINE LAMP FAULT	1. Check engine lamp driver general fault. 2. Check engine lamp driver SC2G (short circuit to ground) fault. 3. Check engine lamp driver SC2V (short circuit to battery voltage) fault. 4. Check engine lamp driver OC (open circuit) fault.										
P1650	13	5712	18	612	E-ECU-200	CHECK ENGINE LAMP OC FAULT	1. Check engine lamp driver general fault. 2. Check engine lamp driver SC2G (short circuit to ground) fault. 3. Check engine lamp driver SC2V (short circuit to battery voltage) fault. 4. Check engine lamp driver OC (open circuit) fault.										
P1660	00	5728	26	883	E-ECU-201	ESM PULSE CHECK FAULT	1. ESM Pulse Check Fault.	O									
P1661	00	5729	26	884	E-ECU-202	ESM PULSE CHECK FAULT	1. ESM Pulse Check Fault.	O									
P1662	00	5730	1	681	E-ECU-203	ENGINE HOUR METER FAULT	1. Engine hour meter fault.										
P1662	03	5730	26	885	E-ECU-204	ESM LEVEL 3 FAULT	1. Engine hour meter fault.	O									
P1663	13	5731	18	682	E-ECU-205	ENGINE HOUR METER OC FAULT	1. Engine hour meter open circuit (OC).										
P1663	03	5731	26	886	E-ECU-206	ESM LEVEL 3 FAULT	1. Engine hour meter open circuit (OC).	O									
P1664	11	5732	20	683	E-ECU-207	ENGINE HOUR METER SC2G FAULT	1. Engine hour meter short circuit to ground (SC2G).										
P1665	12	5733	21	684	E-ECU-208	ENGINE HOUR METER SC2VBATT FAULT	1. Engine hour meter short circuit to battery voltage (SC2VBAT)										
P1666	00	5734	1	685	E-ECU-209	ENGINE SPEED GAUGE FAULT	1. Engine speed gauge fault.										
P1667	13	5735	18	686	E-ECU-210	ENGINE SPEED GAUGE OC FAULT	1. Engine speed gauge open circuit (OC) fault.										
P1668	11	5736	20	687	E-ECU-211	ENGINE SPEED GAUGE SC2G FAULT	1. Engine speed gauge SC2G (short circuit to ground) fault.										
P1669	12	5737	21	688	E-ECU-212	ENGINE SPEED GAUGE SC2VBATT FAULT	1. Engine speed gauge SC2V (short circuit to battery voltage) fault.										
P1690	03	5776	26	888	E-ECU-213	ESM LEVEL 3 FAULT	1. ESM Level 3 Fault.	O									
P1691	03	5777	26	889	E-ECU-214	ESM LEVEL 3 FAULT	1. ESM Level 3 Fault.	O									
P1692	03	5778	26	891	E-ECU-215	ESM LEVEL 3 FAULT	1. ESM Level 3 Fault.	O									
P16D2	00	5842	26	892	E-ECU-216	ESM TORQUE REDUCTION MONITORING FAULT	1. ESM torque reduction monitoring fault	O									
P16D6	00	5846	26	841	E-ECU-217	ESM ENGINE SPEED FAULT	1. ESM Engine Speed Fault.	O									
P16D8	00	5848	26	848	E-ECU-218	ESM PEDAL TRACK FAULT	1. ESM Pedal Track Fault.	O									
P2002	00	8194	28	581	E-ECU-219	DPF OVERLOAD FAULT	1. DPF overload fault.					O					
P2031	00	8241	1	571	E-ECU-220	DPF IN TEMP. SENSOR SIGNAL FAULT	1. DPF in temperature sensor fault.	O									
P2031	64	8241	22	575	E-ECU-221	DPF IN TEMP. SENSOR SIGNAL FAULT	1. DPF in temperature sensor fault.	O									
P2032	23	8242	20	573	E-ECU-222	DPF IN TEMP. SENSOR SC2G FAULT	1. DPF in temperature sensor count low.										
P2033	24	8243	18	572	E-ECU-223	DPF IN TEMP. SENSOR OC OR SC2VBATT FAULT	1. DPF in temperature sensor count high.										
P2081	00	8321	22	469	E-ECU-224	EXHAUST GAS TEMP. SENSOR SIGNAL FAULT	1. Exhaust manifold temperature sensor plausibility fault.	O									
P2100	13	8448	18	541	E-ECU-225	ACV DRIVER OC FAULT	1. ACV H-bridge driver open circuit fault.	O									
P2101	04	8449	4	545	E-ECU-226	ACV H-BRIDGE DRIVER FAULT	1. ACV h-bridge driver over temperature fault. 2. ACV h-bridge driver under voltage.	O									
P2101	04	8449	2	544	E-ECU-227	ACV H-BRIDGE DRIVER FAULT	1. ACV h-bridge driver over temperature fault. 2. ACV h-bridge driver under voltage.	O									
P2102	11	8450	20	542	E-ECU-228	ACV H-BRIDGE DRIVER FAULT	1. ACV H-Bridge driver short to ground fault.	O									
P2103	12	8451	21	543		E-ECU-229	ACV H-BRIDGE DRIVER FAULT		O								

ENGINE - DIAGNOSIS

FAULT CODE						FAULT NAME	DESCRIPTION	ACTION							EGR Inducement		
DTC CODE		J1939		LAMP CODE	CLUSTER CODE			CEL "ON"	DELAYED ENGINE STOP (20s)	CCRT (DPF) REGEN DISABLE OR STOP	INCRE-ASED IDLE (1300 rpm)	DISABLE EACH INJECTOR	LIMP HOME (1400 rpm)	TORQUE REDUCTION (2200 rpm)	EMISSION FAILURE LAMP "ON"	SPEED REDUCTION Warn : N/A Low Level: 60% Severe Level : 60%	TORQUE REDUCTION Warn : N/A Low Level: 25% Severe Level : 50%
HMB	LB	SPN	FMI														
P2118	04	8472	3	546	E-ECU-230	ACV H-BRIDGE DRIVER FAULT	1. ACV driver circuit fault. 2. ACV H-bridge driver current limited fault. 3. ACV H-bridge driver current reduced fault.	O		O							
P2118	04	8472	3	547		ACV H-BRIDGE DRIVER FAULT	1. ACV driver circuit fault. 2. ACV H-bridge driver current limited fault. 3. ACV H-bridge driver current reduced fault.	O		O							
P2119	00	8473	7	534	E-ECU-231	ACV CONTROL FAULT	1. ACV control fault.	O		O							
P2120	00	8480	23	441	E-ECU-232	HAND PEDAL SIGNAL TRACK1 FAULT	1. Hand pedal signal track 1 fault.	O			O						
P2125	00	8485	24	442	E-ECU-233	HAND PEDAL SIGNAL TRACK2 FAULT	1. Hand pedal signal track 2 fault.	O			O						
P2135	00	8501	1	435	E-ECU-234	FOOT PEDAL CORRELATION FAULT	1. Foot pedal signal fault set (triggers limp home mode). 2. Consider using manufacturer's specific code for these Foot pedal faults.	O			O						
P2138	00	8504	1	445	E-ECU-235	HAND PEDAL CORRELATION FAULT	1. Hand pedal signal fault set (triggers limp home mode). 2. Consider using manufacturer's specific code for these hand pedal faults.	O			O						
P2228	23	8744	5	813	E-ECU-236	ATMOSPHERIC SENSOR LOW FAULT	1. Atmospheric sensor low fault.	O									
P2229	24	8745	6	812	E-ECU-237	ATMOSPHERIC SENSOR HIGH FAULT	1. Atmospheric sensor high fault.										
P2264	24	8804	8	492	E-ECU-238	WATER IN FUEL SENSOR FEEDBACK FAULT	1. Water in fuel sensor feedback signal Short to circuit to ground fault. 2. Water in fuel sensor feedback signal Short to circuit to battery fault. 3. Water in fuel sensor feedback signal Open circuit fault.	O				O					
P2264	23	8804	9	491	E-ECU-239	WATER IN FUEL SENSOR FEEDBACK FAULT	1. Water in fuel sensor feedback signal Short to circuit to ground fault. 2. Water in fuel sensor feedback signal Short to circuit to battery fault. 3. Water in fuel sensor feedback signal Open circuit fault.	O				O					
P2269	64	8809	1	493	E-ECU-240	WATER IN FUEL SENSOR DETECT FAULT	1. Water in fuel sensor detected.				O						
P242F	00	9263	28	582	E-ECU-241	DPF PLUGGED FAULT	1. DPF plugged fault.	O		O		O (1500 rpm)					
P2453	00	9299	1	565	E-ECU-242	DPF DIFF.PRESS SENSOR PLAUSIBILITY FAULT	1. DPF differential pressure sensor signal plausibility fault. (Clamped tube inlet side, DP sensor tubes inverted).	O		O							
P2453	64	9299	22	564	E-ECU-243	DPF DIFF.PRESS SENSOR PLAUSIBILITY FAULT	1. DPF differential pressure sensor signal plausibility fault. (Clamped tube inlet side, DP sensor tubes inverted).	O		O							
P2454	23	9300	20	562	E-ECU-244	DPF DIFF. PRESS SENSOR SC2G FAULT	1. DPF differential press sensor signal low fault.	O		O							
P2455	24	9301	18	561	E-ECU-245	DPF DIFF. PRESS SENSOR OC OR SC2VBATT FAULT	1. DPF differential press sensor signal high fault.	O		O							
P246B	00	9323	1	653	E-ECU-246	DPF REGENERATION SWITCH FAULT	1. DPF regeneration switch fault.	O									
P2485	00	9349	29	563	E-ECU-247	DPF DIFF. PRESS LEAK FAULT	1. DPF differential pressure leak fault.	O		O							
P2BC0	0	11200	0	777	E-ECU-248	SCR INDUCEMENT_WARNING1 FAULT	1. SCR Inducement State is Warning 1 Error. 2. DEF Level Error. 3. DEF Quality Error . 4. DEF Dosing Failure Dosing Failure. 5. EGR & SCR System Failure. 6. CAN Failure"										
P2BC1	0	11201	0	778	E-ECU-249	SCR INDUCEMENT_WARNING2 FAULT	1. SCR Inducement State is Warning 2 Error. 2. DEF Level Error. 3. DEF Quality Error . 4. DEF Dosing Failure Dosing Failure. 5. EGR & SCR System Failure. 6. CAN Failure"										

ENGINE - DIAGNOSIS

FAULT CODE					FAULT NAME	DESCRIPTION	ACTION							EGR Inducement			
DTC CODE		J1939		LAMP CODE			CLUSTER CODE	CEL"ON"	DELAYED ENGINE STOP (20s)	CCRT (DPF) REGEN DISABLE OR STOP	INCRE-ASED IDLE (1300 rpm)	DISABLE EACH INJECTOR	LIMP HOME (1400 rpm)	TORQUE REDUCTION (2200 rpm)	EMISSION FAILURE LAMP "ON"	SPEED REDUCTION Warn : N/A Low Level: N/A Severe Level : 60%	TORQUE REDUCTION Warn : N/A Low Level: 25% Severe Level : 50%
HMB	LB	SPN	FMI														
P2BC2	0	11202	0	779	E-ECU-250	SCR INDUCEMENT_WARNING3(Low) FAULT											
P2BC3	0	11203	0	780	E-ECU-251	SCR INDUCEMENT_WARNING4(SEVERE) FAULT											
P027F	0	639	0	942	E-ECU-252	CAN TIMEOUT FAULT											
P027F	1	639	0	942		CAN TIMEOUT FAULT											
P0003	7B	94	8	351	-	IMV CONTROL FAULT 2											
P0004	7B	94	9	352	-	IMV CONTROL FAULT 1											
P0088	01	521015	31	357	-	RAIL PRESSURE OVER TIME FAULT											
P018F	00	521516	31	358	-	PRESSURE LIMIT VALVE OPEN FAULT											
P1219	01	16383	1	947	-	VDG RPM FAULT											

SAFETY FIRST

ENGINE

DRIVING & CHASSIS

HYDRAULIC SYSTEM

ELECTRIC SYSTEM

CABIN

INDEX



## 8.2.3 FAULT DIAGNOSIS CODE DESCRIPTION

**CHECK DEVICE**

CHECK POINT	REMARK
1. CHECK DTC CODE	1. Read diagnostic trouble code.
2. DEVICE HARDWARE CHECK	1. Visually check device hardware.
3. CHECK VEXT (Supply Voltage) Fault	1. Disconnect sensor one by one checking if disappear to find which one is faulty. (Problem with one of the sensors causing loss of supply voltage) 2. If none is found faulty, check short circuit or isolation of Vext lines of harness.
4. CHECK DEVICE CONNECTION	1. Pin to Pin check (Device Connector, ECU Connector, Wire Harness) (* See the Attached Wire Harness Drawing)

**RELAY**

CHECK POINT	REMARK
1. RELAY CHECK	1. Relay shortage check. 2. Pin to Pin Check (Sensor Connector, ECU Connector, Wire Harness) (* See the Attached Wire Harness Drawings.)

**SWITCH**

CHECK POINT	REMARK
1. SWITCH CHECK	1. Check 12V supply from the battery. 2. Pin to Pin Check (Sensor Connector, ECU Connector, Wire Harness) (* See the Attached Wire Harness Drawings.)
2. REPLACE THE SWITCH	1. Replace the switch.

SAFETY FIRST

**ECU**

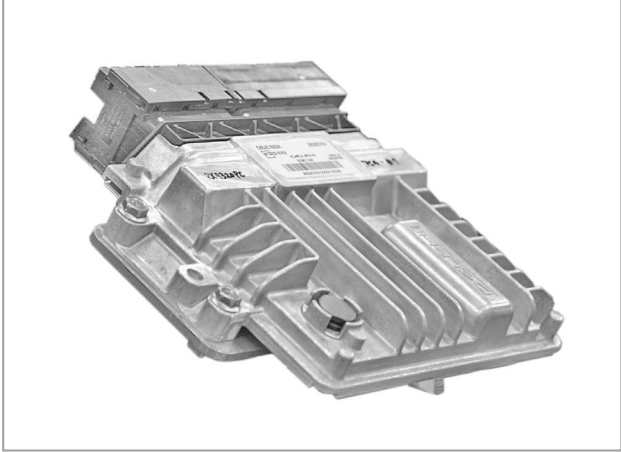
CHECK POINT	REMARK
1. CHECK DTC CODE	1. Read diagnostic trouble code. 2. If other fault is present, first check corresponding fault.
2. ECU HARDWARE CHECK	<div style="text-align: center;">  </div> 1. Visually check ECU pins.
3. ECU CONNECTOR / WIRE HARNESS CHECK	1. Pin to Pin Check. (Sensor Connector, ECU Connector, Wire Harness) 2. Check electrical isolation.
4. CHECK GROUND CONNECTION OF VEHICLE CHASSIS	1. Check ground connection of vehicle chassis

ENGINE

DRIVING & CHASSIS

HYDRAULIC SYSTEM

**ECU R&R**

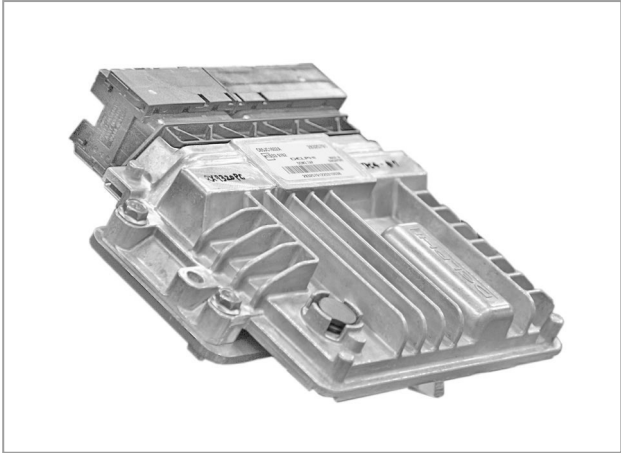
CHECK POINT	REMARK
1. ECU CONNECTOR / WIRE HARNESS CHECK	<div style="text-align: center;">  </div> 1. Pin to Pin Check. (Sensor Connector, ECU Connector, Wire Harness)
2. CHANGE THE ECU	1. Change the ECU. 2. When you change the ECU, you should follow scan tool's ECU change rules.(Current ECU has much engine information, so this information should be carried on new ECU by scan tool.)

ELECTRIC SYSTEM

CABIN

INDEX



**ECU DATA ERROR**

CHECK POINT	REMARK
1. CHECK DTC CODE	1. Read diagnostic trouble code. 2. If other fault is present, first check corresponding fault.
2. ECU HARDWARE CHECK	<div data-bbox="719 439 1342 891" data-label="Image"> </div> 1. Visually check ECU pins.
3. ECU CONNECTOR / WIRE HARNESS CHECK	1. Pin to Pin Check. (Sensor Connector, ECU Connector, Wire Harness) 2. Check electrical isolation.
4. CHECK GROUND CONNECTION OF VEHICLE CHASSIS	1. Check ground connection of vehicle chassis
5. REPROGRAM ECU SOFTWARE & REWRITE C3I CODE TRY TO FILTER MANUAL REGENERATION	1. Reprogram ECU software. 2. Rewrite Injector Code (C3I) Code. (20 Letters) (Please take care of injector position.) 3. Try to filter manual regeneration. <ol style="list-style-type: none"> <li>1) Move the vehicle to safety zone</li> <li>2) Lock the brake Warm engine (coolant over 60° C).</li> <li>3) Do Manual regeneration:                             <ol style="list-style-type: none"> <li>a. Push the Manual regeneration switch during 2 sec.</li> <li>b. Or, do Manual regeneration using scan tool.</li> </ol> </li> <li>4) It would take about 25min.</li> <li>5) After regeneration successful, fault would not be raised.</li> </ol>
6. REPLACE ECU	1. If above no.5 is not available, replace the ECU.

**HIGH PRESSURE DIAGNOSTIC**

SAFETY FIRST

ENGINE

DRIVING & CHASSIS

HYDRAULIC SYSTEM

ELECTRIC SYSTEM

CABIN

INDEX

CHECK POINT	REMARK
1. CHECK DTC CODE	1. Read diagnostic code (DTC) in the scan tool . 2. Find out which problem; IMV, HP pump, Rail press sensor.
2. FUEL, AIR AND CIRCUIT CHECK	<div data-bbox="815 432 1217 884" data-label="Image"> </div> <ol style="list-style-type: none"> <li>1. Check the fuel feed circuit is in good condition.</li> <li>2. Check diesel is in the system</li> <li>3. Check any air in the system (Should be no air and no bubble)</li> <li>4. Check the enough fuel pressure in the inlet pump.</li> <li>5. Check leak on the high pressure pump.</li> <li>6. Check diesel fuel of the correct quality and type.</li> </ol>
3. RAIL PRESSURE CHECK	<div data-bbox="820 1153 1212 1606" data-label="Image"> </div> <p>(1) Fuel temp. sensor (2) IMV (Inlet Metering Valve) (3) IMV connector</p> <ol style="list-style-type: none"> <li>1. Compare with rail pressure demand and feedback.</li> <li>2. If there's no rail press, replace IMV (Inlet Metering Valve).</li> <li>3. If there is hunting, replace IMV connector (contact failure).</li> </ol>
4. BACKLEAK TEST	<ol style="list-style-type: none"> <li>1. Do Back Leak Test, if available.</li> <li>2. If back leak is above limit, replace corresponding injector.</li> </ol>
5. IMV BUZZING TEST	<ol style="list-style-type: none"> <li>1. Do IMV Buzzing test using scan tool.</li> <li>2. If there is resistance problem, replace the IMV.</li> </ol>

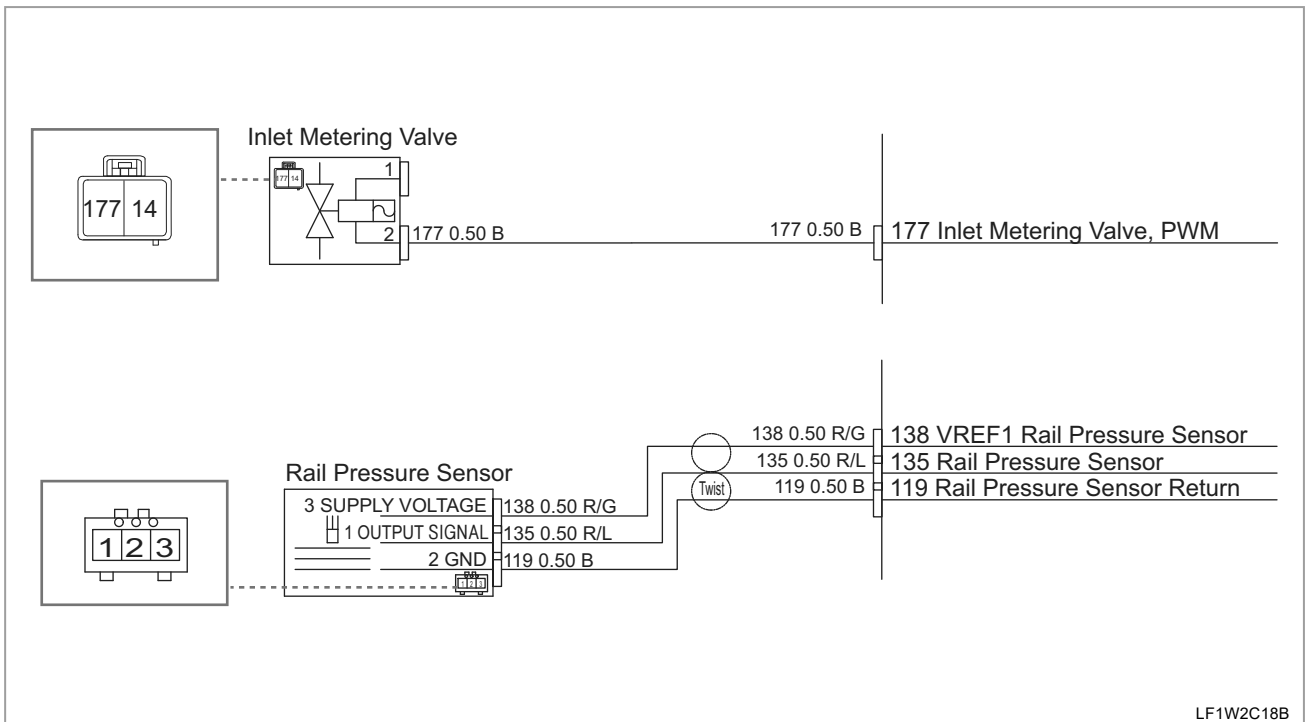

SAFETY FIRST

ENGINE

DRIVING & CHASSIS

HYDRAULIC SYSTEM

ELECTRIC SYSTEM

CABIN

INDEX

**IMV**

SAFETY FIRST

ENGINE

DRIVING & CHASSIS

HYDRAULIC SYSTEM

ELECTRIC SYSTEM

CABIN

INDEX

CHECK POINT	REMARK
<p>1. IMV CONNECTOR/WIRE HARNESS CHECK</p>	<div data-bbox="815 349 1217 801" data-label="Image"> <p style="text-align: right; font-size: small;">ST5WC03A</p> </div> <p>1. Pin to Pin Check (Sensor Connector, ECU Connector, Wire Harness)                  2. Check electrical isolation.                  (*) See the Attached Wire Harness Drawings.</p>
<p>2. MEASURE IMV ELECTRICAL RESISTANCE</p>	<p>1. Check IMV electrical resistance. (Around 5.3Ω at 20° C)                  2. If there is resistance problem, replace the IMV.</p>
<p>3. RAIL PRESSURE CHECK</p>	<div data-bbox="820 1043 1211 1496" data-label="Image"> <p style="text-align: right; font-size: small;">ST5WC04A</p> </div> <p>(1) Fuel temp. sensor (2) IMV (Inlet Metering Valve) (3) IMV connector</p> <p>1. Compare with rail pressure demand and feedback.                  2. If there's no rail press, replace IMV (Inlet Metering Valve).                  3. If there is hunting, replace IMV connector (contact failure).</p>
<p>4. IMV BUZZING TEST</p>	<p>1. Do IMV Buzzing test using scan tool.                  2. If there is resistance problem, replace the IMV.</p>

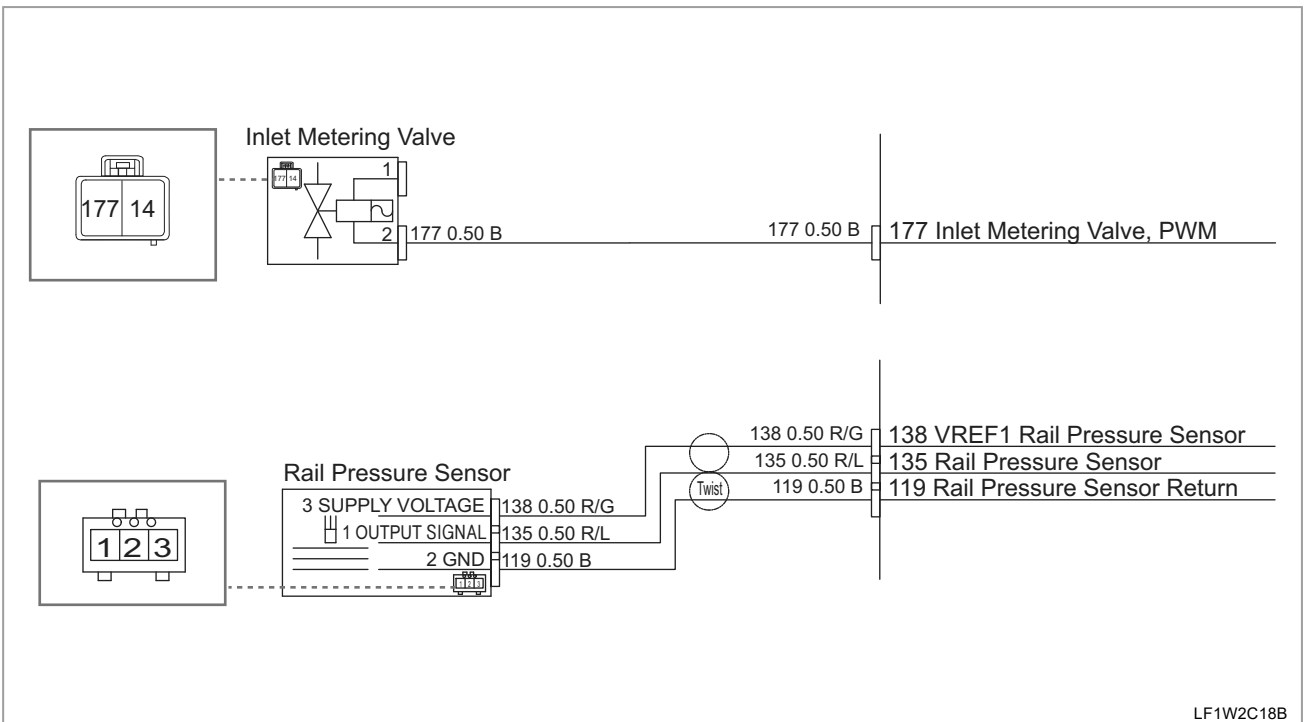

**RAIL PRESSURE**

SAFETY FIRST

ENGINE

DRIVING & CHASSIS

HYDRAULIC SYSTEM

ELECTRIC SYSTEM

CABIN

INDEX

CHECK POINT	REMARK
<p>1. RAIL PRESSURE SENSOR CHECK</p>	<div data-bbox="703 347 1326 797" data-label="Image"> </div> <p data-bbox="1220 779 1316 797">LF1W2B65A</p> <p data-bbox="608 815 1374 882">1. Pin to Pin Check (Sensor Connector, ECU Connector, Wire Harness) (* ) See the Attached Wire Harness Drawings.</p>
<p>2. REPLACE THE RAIL</p>	<p data-bbox="608 916 1198 947">1. If there is rail press. sensor problem, replace the rail.</p>

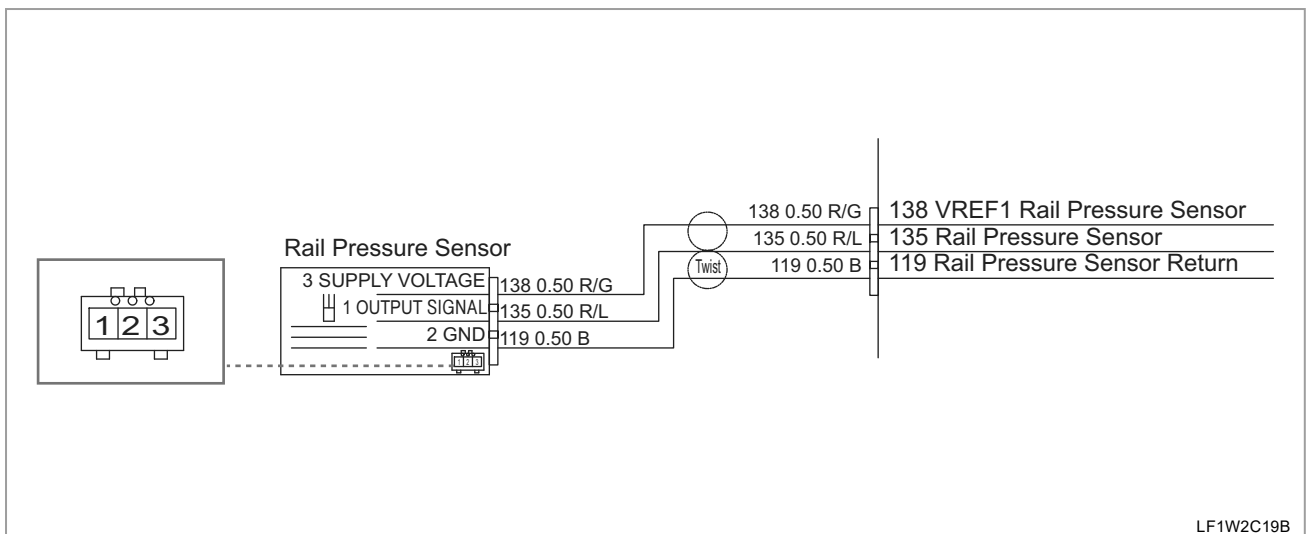

**RAIL EXCESSIVE PRESURE**

CHECK POINT	REMARK
<p>1. RAIL PRESSURE CHECK</p>	<div data-bbox="831 365 1233 815" data-label="Image"> </div> <p>(1) Fuel temp. sensor (2) IMV (Inlet Metering Valve) (3) IMV connector</p> <ol style="list-style-type: none"> <li>1. Compare with rail pressure demand and feedback.</li> <li>2. If there's no rail press, replace IMV (Inlet Metering Valve).</li> <li>3. If there is hunting, replace IMV connector (contact failure).</li> </ol>
<p>2. RAIL PRESSURE SENSOR CHECK</p>	<div data-bbox="721 1025 1345 1476" data-label="Image"> </div> <p>1. Pin to Pin Check (Sensor Connector, ECU Connector, Wire Harness)                      (*) See the Attached Wire Harness Drawings.</p>
<p>3. REPLACE THE RAIL</p>	<p>1. If there is rail press. sensor problem, replace the rail.</p>

CHECK POINT	REMARK
<p>4. IMV CONNECTOR/WARE HARNESS CHECK</p>	<div data-bbox="813 347 1220 795" style="text-align: center;"> <p>ST5WC03A</p> </div> <ol style="list-style-type: none"> <li>1. Pin to Pin Check (Sensor Connector, ECU Connector, Wire Harness)</li> <li>2. Check electrical isolation.</li> </ol> <p>(* ) See the Attached Wire Harness Drawings.</p>
<p>5. MEASURE IMV ELECTRICAL RESISTANCE</p>	<ol style="list-style-type: none"> <li>1. Check IMV electrical resistance. (Around 5.3Ω at 20° C)</li> <li>2. If there is resistance problem, replace the IMV.</li> </ol>
<p>6. IMV BUZZING TEST</p>	<ol style="list-style-type: none"> <li>1. Do IMV Buzzing test using scan tool.</li> <li>2. If there is resistance problem, replace the IMV.</li> </ol>

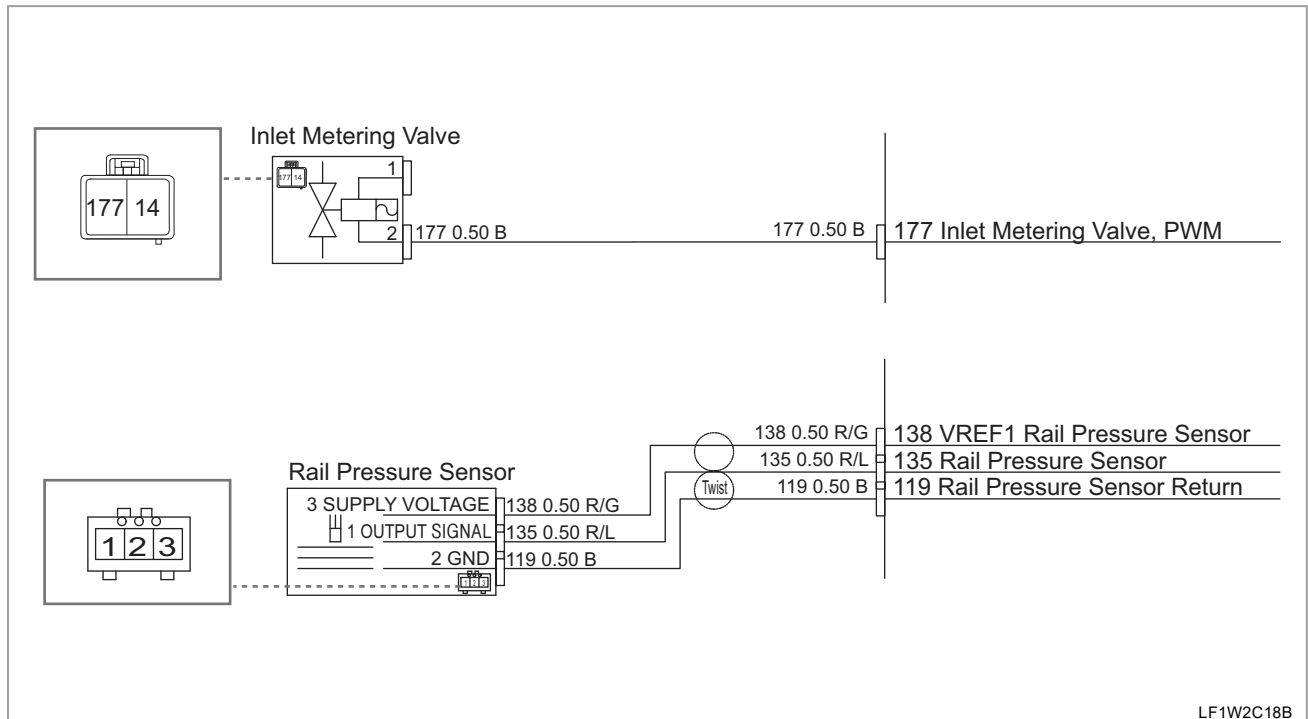

LF1W2C18B



**RAIL PRESSURE CONTROL ERROR**

CHECK POINT	REMARK
<p>1. FUEL, AIR AND CIRCUIT CHECK</p>	<div data-bbox="719 369 1342 819" data-label="Image"> </div> <ol style="list-style-type: none"> <li>1. Check the fuel feed circuit is in good condition.</li> <li>2. Check diesel is in the system</li> <li>3. Check any air in the system (Should be no air and no bubble)</li> <li>4. Check the enough fuel pressure in the inlet pump.</li> <li>5. Check leak on the high pressure pump.</li> <li>6. Check diesel fuel of the correct quality and type.</li> </ol>
<p>2. IMV CONNECTOR/WARE HARNESS CHECK</p>	<div data-bbox="831 1077 1230 1527" data-label="Image"> </div> <ol style="list-style-type: none"> <li>1. Pin to Pin Check (Sensor Connector, ECU Connector, Wire Harness)</li> <li>2. Check electrical isolation.</li> </ol> <p>(*) See the Attached Wire Harness Drawings.</p>
<p>3. MEASURE IMV ELECTRICAL RESISTANCE</p>	<ol style="list-style-type: none"> <li>1. Check IMV electrical resistance. (Around 5.3Ω at 20° C)</li> <li>2. If there is resistance problem, replace the IMV.</li> </ol>

CHECK POINT	REMARK
<p>4. RAIL PRESSURE CHECK</p>	<div data-bbox="821 362 1212 817" style="text-align: center;"> <p>ST5WC04A</p> </div> <p>(1) Fuel temp. sensor (2) IMV (Inlet Metering Valve) (3) IMV connector</p> <ol style="list-style-type: none"> <li>1. Compare with rail pressure demand and feedback.</li> <li>2. If there's no rail press, replace IMV (Inlet Metering Valve).</li> <li>3. If there is hunting, replace IMV connector (contact failure).</li> </ol>
<p>5. IMV BUZZING TEST</p>	<ol style="list-style-type: none"> <li>1. Do IMV Buzzing test using scan tool.</li> <li>2. If there is resistance problem, replace the IMV.</li> </ol>

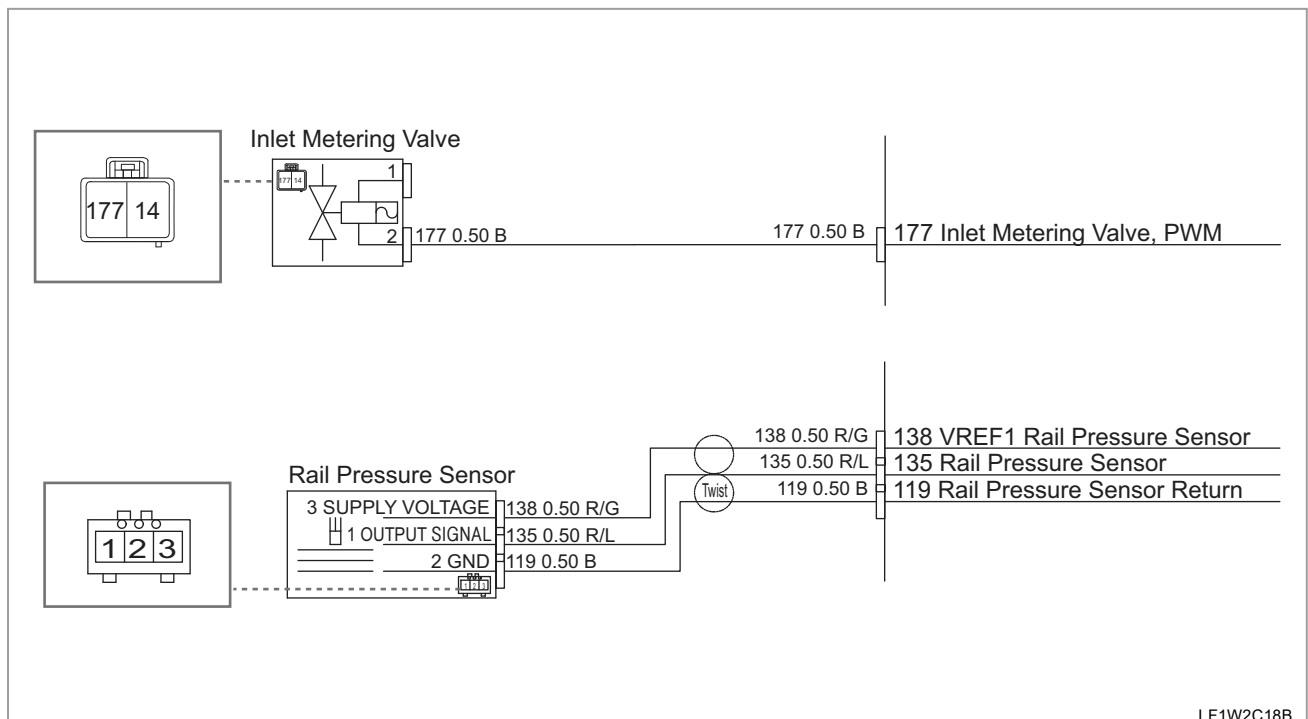

LF1W2C18B

**RAIL PRESSURE CALIBRATION**

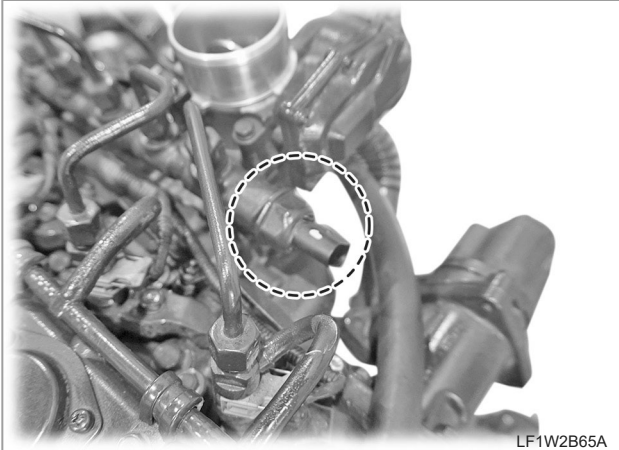
CHECK POINT	REMARK
1. POOR DETECTION	1. This fault could be caused by pushing vehicle while engine is off. (Poor detection) 2. Clear the fault.
2. SENSOR / WIRE HARNESS CHECK	<div data-bbox="721 470 1343 918" style="text-align: center;">  <p style="text-align: right; font-size: small;">LF1W2B65A</p> </div> 1. Pin to Pin Check (Sensor Connector, ECU Connector, Wire Harness) (*) See the Attached Wire Harness Drawings.

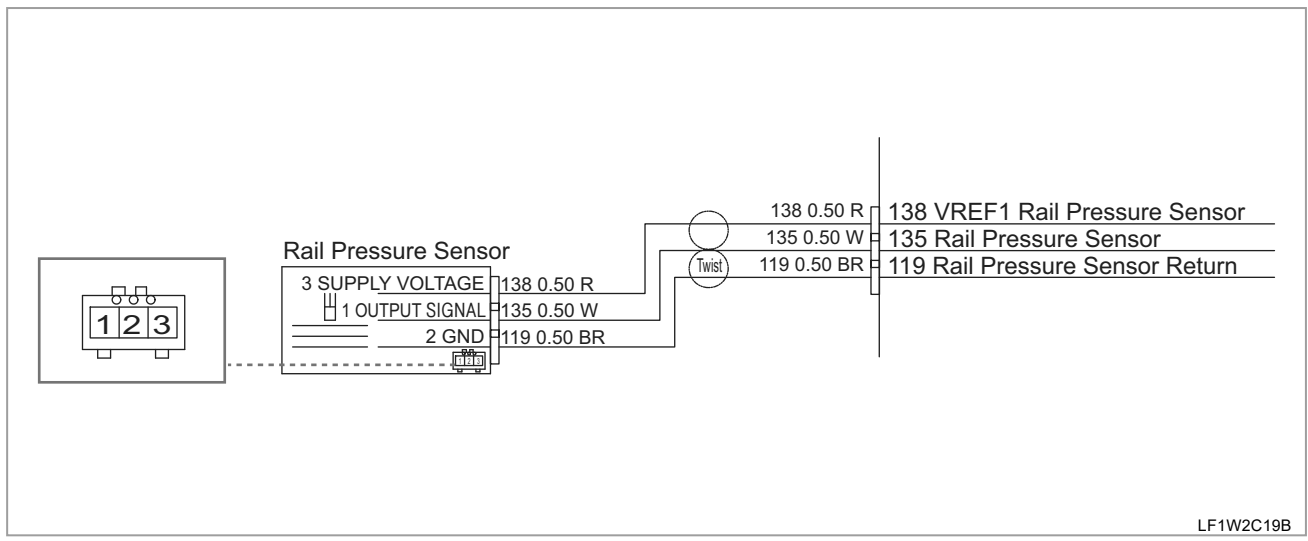

**SENSOR**

CHECK POINT	REMARK
1. SENSOR CHECK	1. Pin to Pin Check (Sensor Connect , ECU Connector, Wire Harness)
2. REPLACE THE SENSOR	1. Replace the sensor.

**ENGINE HOUR METER**

CHECK POINT	REMARK
1. LA CHECK	 <p>LF1W2B67A</p> <p>1. Pin to Pin Check (Sensor Connect , ECU Connector, Wire Harness) (*) See the Attached Wire Harness Drawings.</p>
2. REPLACE LA	1. Replace la

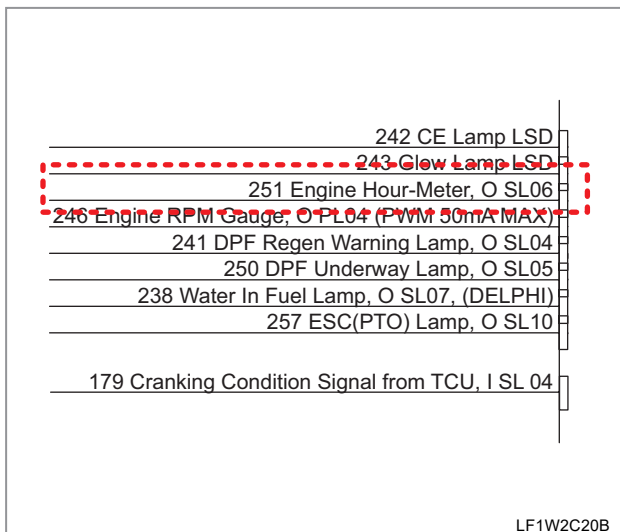

**ENGINE SPEED GAUGE SENSOR**

CHECK POINT	REMARK
<p>1. LAMP CHECK</p>	<div data-bbox="718 336 1340 940" style="text-align: center;"> <p>LF1W2B68A</p> </div> <p>1. Pin to Pin Check (Sensor Connector, ECU Connector, Wire Harness)                      (*) See the Attached Wire Harness Drawings.</p>
<p>2. REPLACE LAMP</p>	<p>1. Replace lamp</p>

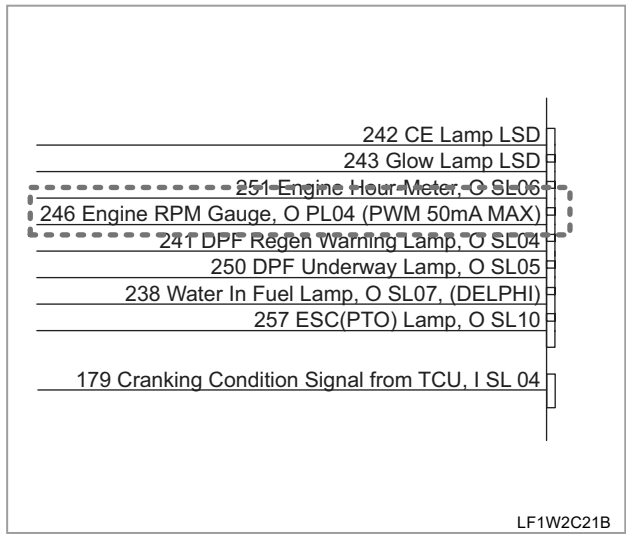

**GLOW PLUG SENSOR**

SAFETY FIRST

ENGINE

DRIVING & CHASSIS

HYDRAULIC SYSTEM

ELECTRIC SYSTEM

CABIN

INDEX

CHECK POINT	REMARK
<p>1. LAMP CHECK</p>	<div data-bbox="703 338 1329 943" style="text-align: center;"> <p>LF1W2B69A</p> </div> <p>1. Pin to Pin Check (Sensor Connector, ECU Connector, Wire Harness)                      (*) See the Attached Wire Harness Drawings.</p>
<p>2. REPLACE LAMP</p>	<p>1. Replace lamp</p>

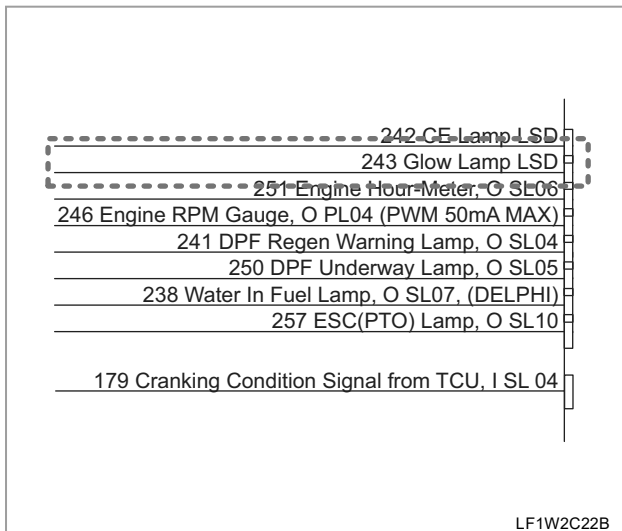

**WATER IN FUEL SENSOR**

CHECK POINT	REMARK
<p>1. LAMP CHECK</p>	<div data-bbox="718 336 1348 952" style="text-align: center;"> <p>LF1W2B70A</p> </div> <p>1. Pin to Pin Check (Sensor Connector, ECU Connector, Wire Harness)                      (*) See the Attached Wire Harness Drawings.</p>
<p>2. REPLACE LAMP</p>	<p>1. Replace lamp</p>

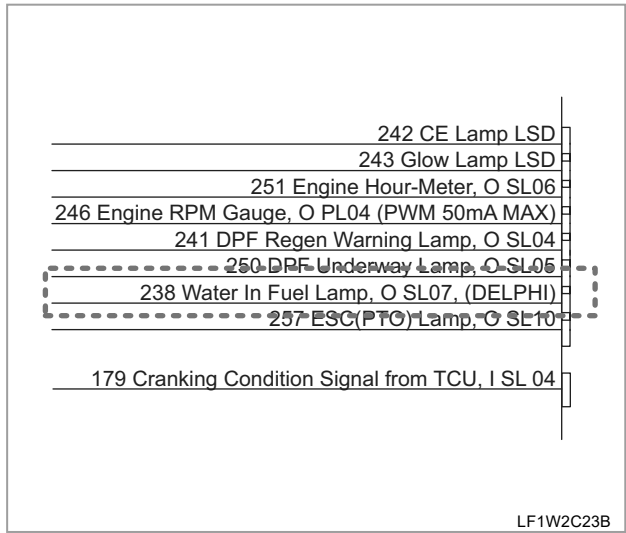

**CHECK ENGINE SENSOR**

SAFETY FIRST

ENGINE

DRIVING & CHASSIS

HYDRAULIC SYSTEM

ELECTRIC SYSTEM

CABIN

INDEX

CHECK POINT	REMARK
<p>1. LAMP CHECK</p>	<div data-bbox="703 338 1329 943" data-label="Image"> </div> <p>LF1W2B71A</p> <p>1. Pin to Pin Check (Sensor Connector, ECU Connector, Wire Harness)                      (*) See the Attached Wire Harness Drawings.</p>
<p>2. REPLACE LAMP</p>	<p>1. Replace lamp</p>

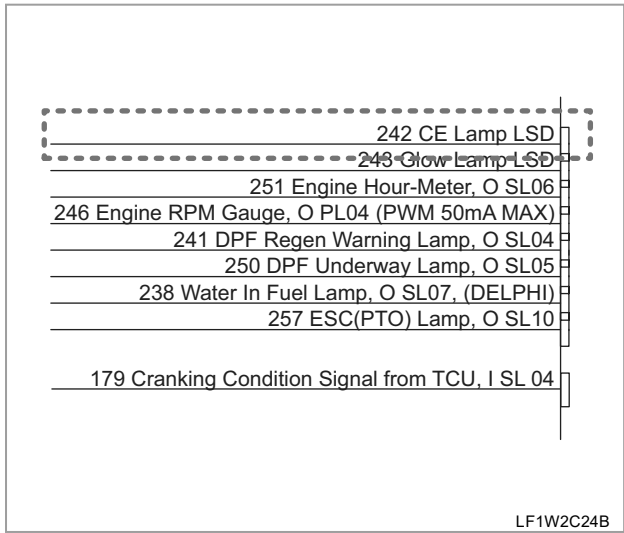

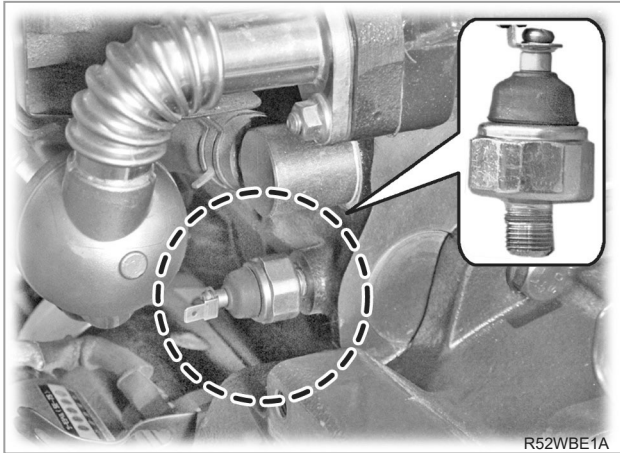

**ENGINE OIL SENSOR**

CHECK POINT	REMARK
1. SENSOR CHECK	 <p>1. Pin to Pin Check (Sensor Connector, ECU Connector, Wire Harness) (* ) See the Attached Wire Harness Drawings.</p>
2. REPLACE THE SENSOR	1. Replace the sensor.
3. LOW OIL PRESSURE COMMON CHECK	1. See the workshop manual; TROUBLE SHOOTING

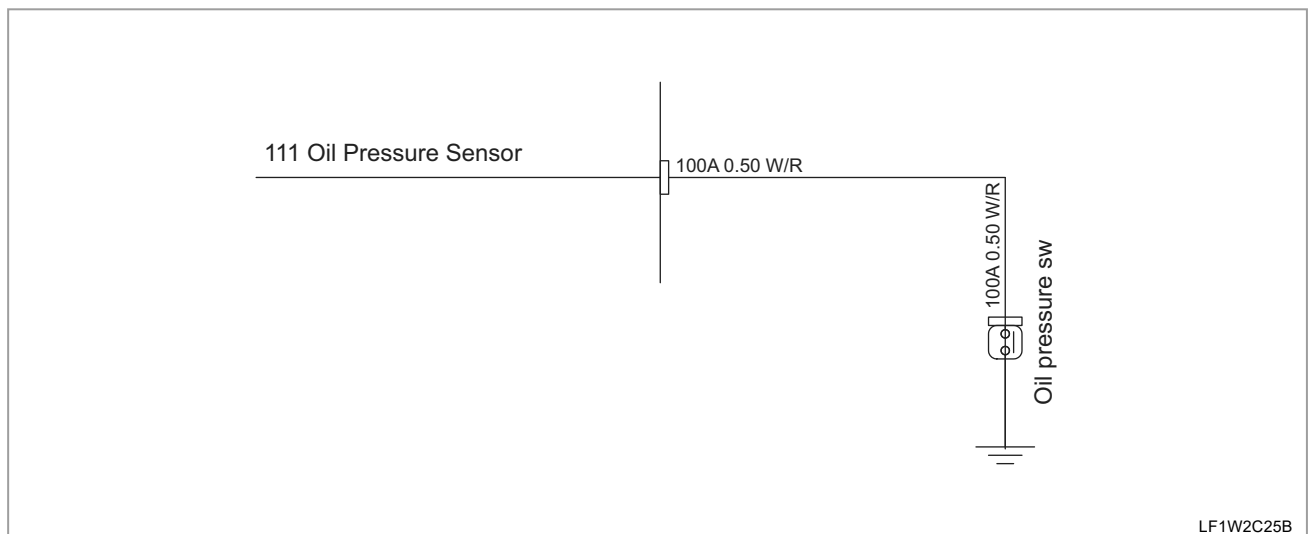

**FUEL TEMP. SENSOR**

CHECK POINT	REMARK
1. SENSOR CHECK	<div data-bbox="821 347 1212 795" style="text-align: center;"> </div> <p>(1) Fuel temp. sensor (2) IMV (Inlet Metering Valve) (3) IMV connector</p> <p>1. Pin to Pin Check (Sensor Connector, ECU Connector, Wire Harness)</p> <p>(* See the Attached Wire Harness Drawings.</p>

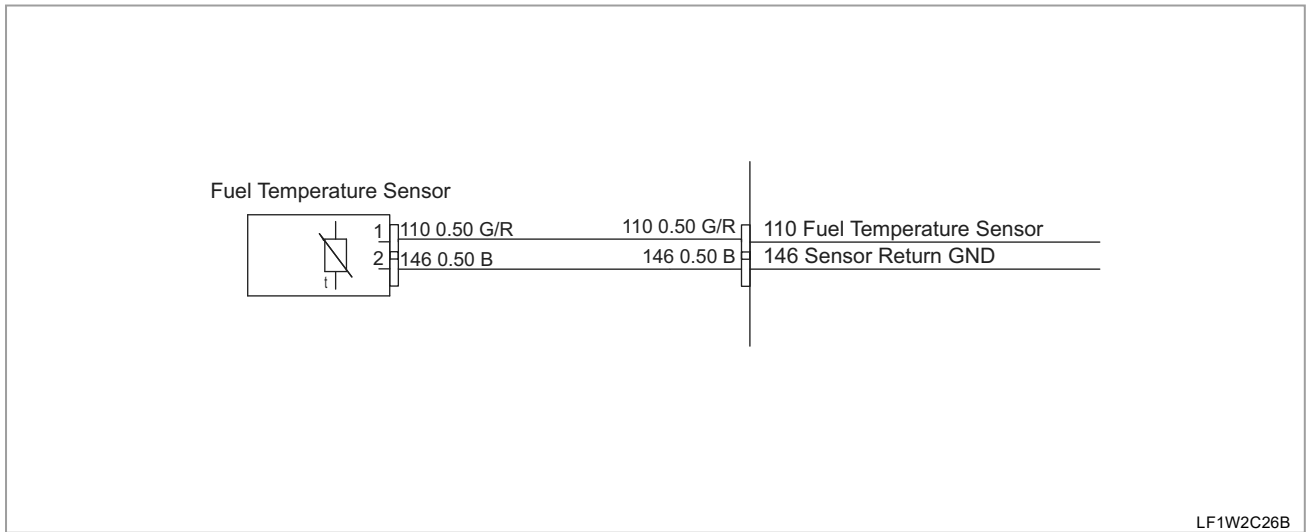

**KNOCK SENSOR**

CHECK POINT	REMARK
1. KNOCK SENSOR CHECK	<div data-bbox="719 347 1342 797" data-label="Image"> </div> <p data-bbox="624 822 1337 891">1. Check the individual knock sensor. (Installation and connection) (*) See the Attached Wire Harness Drawings.</p>

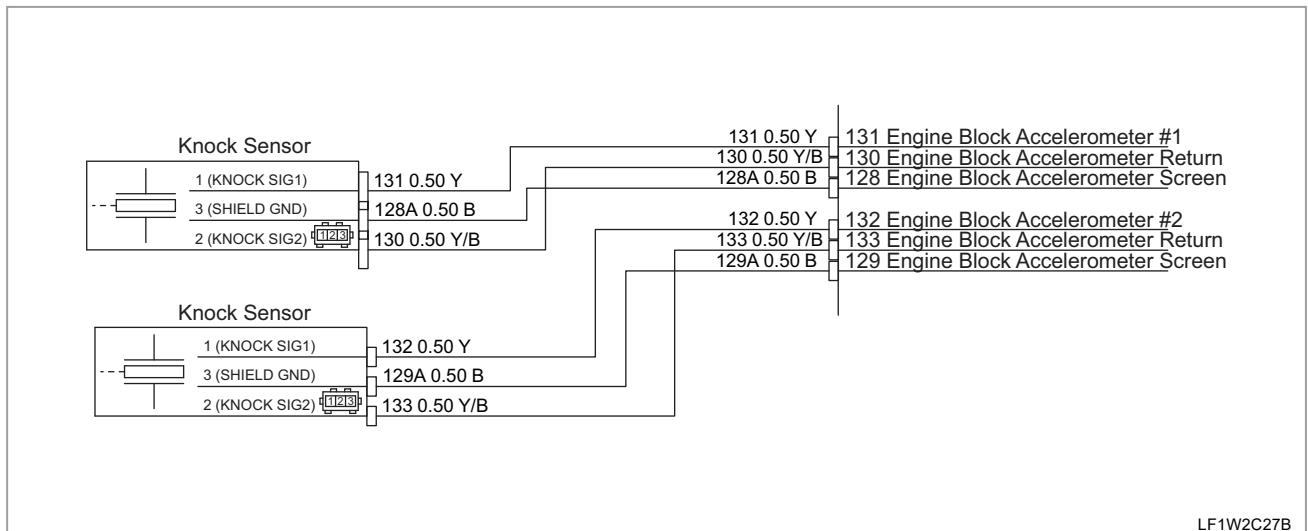

**INTAKE MANIFOLD / TEMP. & PRESSURE SENSOR**

SAFETY FIRST

ENGINE

DRIVING & CHASSIS

HYDRAULIC SYSTEM

ELECTRIC SYSTEM

CABIN

INDEX

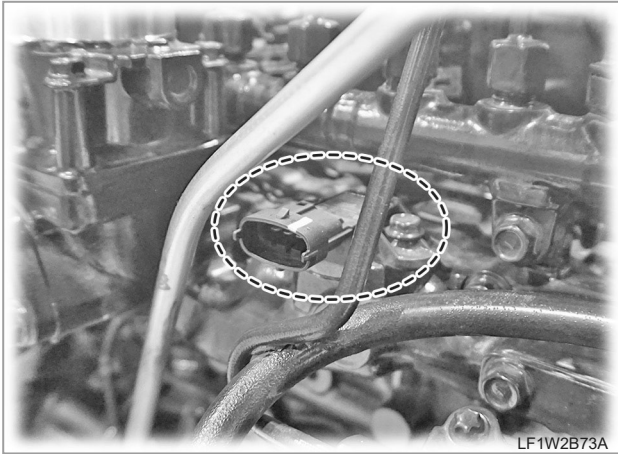
CHECK POINT	REMARK
1. SENSOR CHECK	 <p style="text-align: right; margin-right: 20px;">LF1W2B73A</p> <p>1. Pin to Pin Check (Sensor Connector, ECU Connector, Wire Harness) (* ) See the Attached Wire Harness Drawings.</p>
2. REPLACE THE SENSOR	1. Replace the sensor.

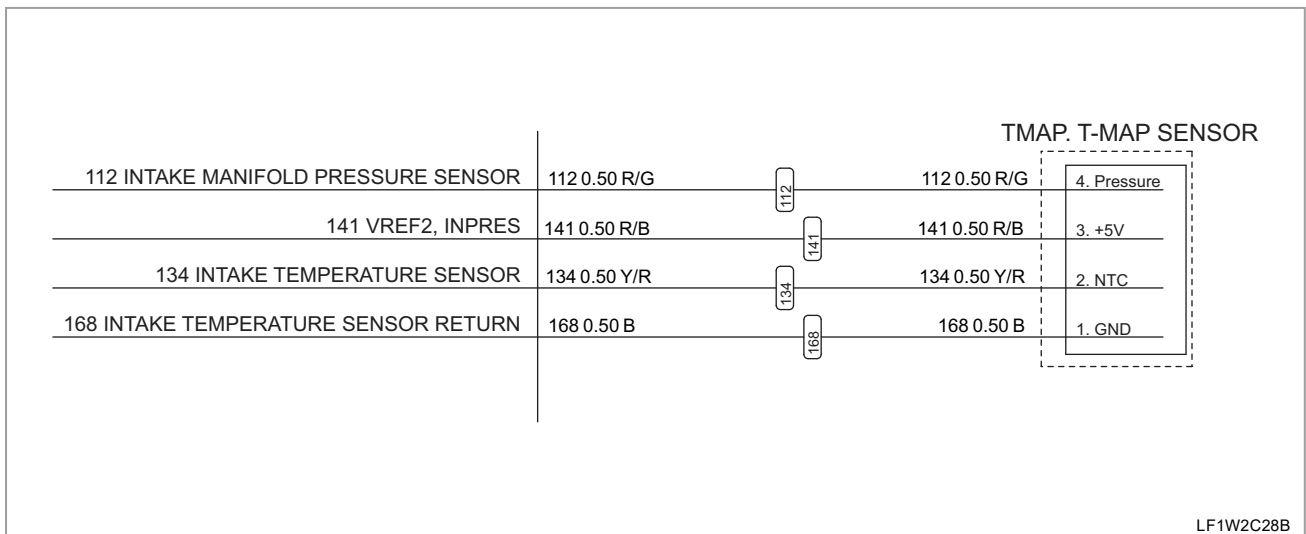

**EXHAUST MANIFOLD SENSOR**

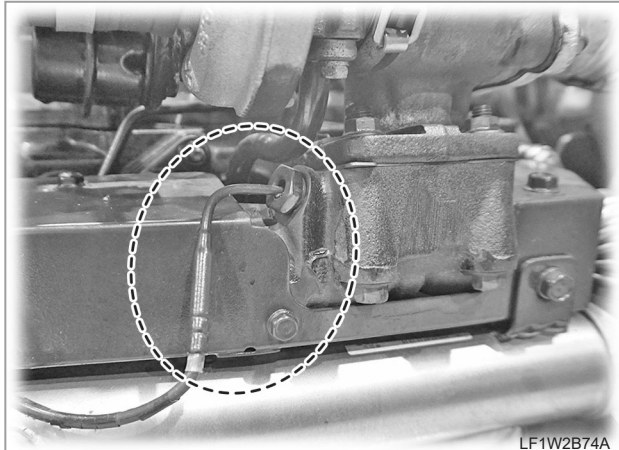
CHECK POINT	REMARK
1. CHECK SENSOR	 <p>1. Pin to Pin Check (Sensor Connector, ECU Connector, Wire Harness) (* ) See the Attached Wire Harness Drawings.</p>
2. REPLACE THE SENSOR	1. Replace the sensor.

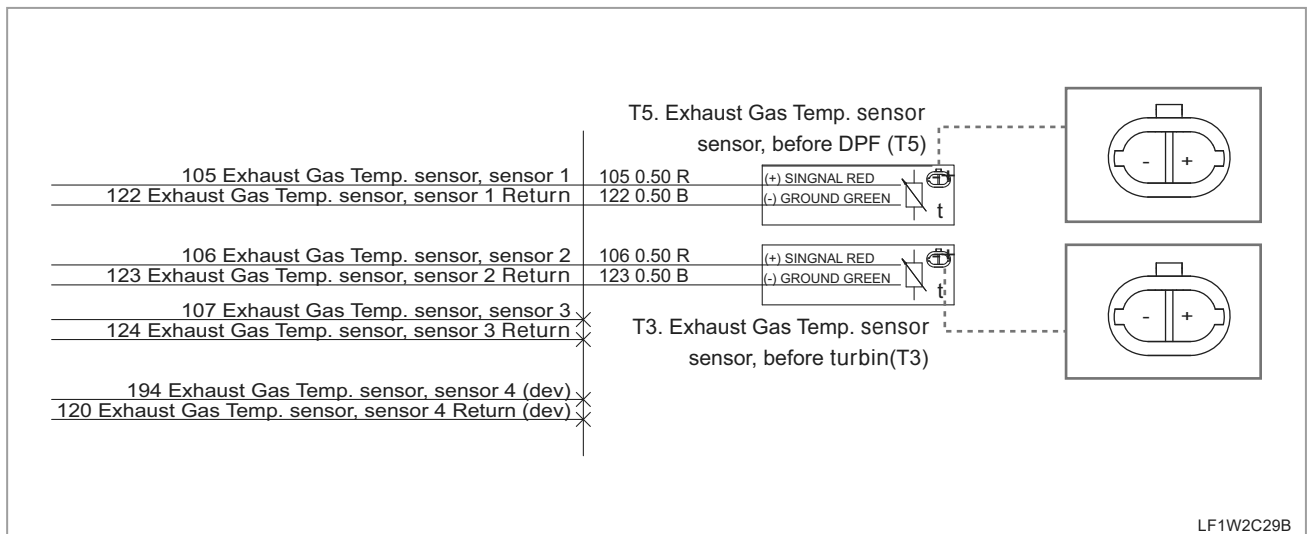

SAFETY FIRST

ENGINE

DRIVING & CHASSIS



HYDRAULIC SYSTEM

ELECTRIC SYSTEM

CABIN

INDEX

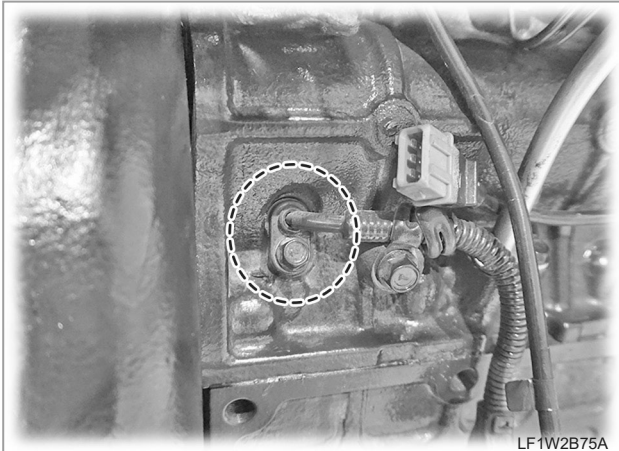
**CRANK SENSOR**

CHECK POINT	REMARK
<p>1. CHECK SENSOR CONNECTION</p>	 <p style="text-align: right; font-size: small;">LF1W2B75A</p>  <p style="text-align: right; font-size: small;">C23WC57A</p>
<p>2. CRANK SENSOR CONNECTOR / WIRE HARNESS CHECK</p>	<p>1. Pin to Pin Check (Sensor Connector, ECU Connector, Wire Harness)                  2. Check electrical isolation.                  (*) See the Attached Wire Harness Drawings.</p>
<p>3. CHECK CAM AND CRANK SIGNAL</p>	<p>1. Signal is unstable or strange, change the sensor.</p>
<p>4. CHECK TARGET WHEEL</p>	<p>1. Visually check the wheel damage.                  2. Check installation position of the wheel.                  3. If problem is still present, fit new crank position sensor wheel.</p>

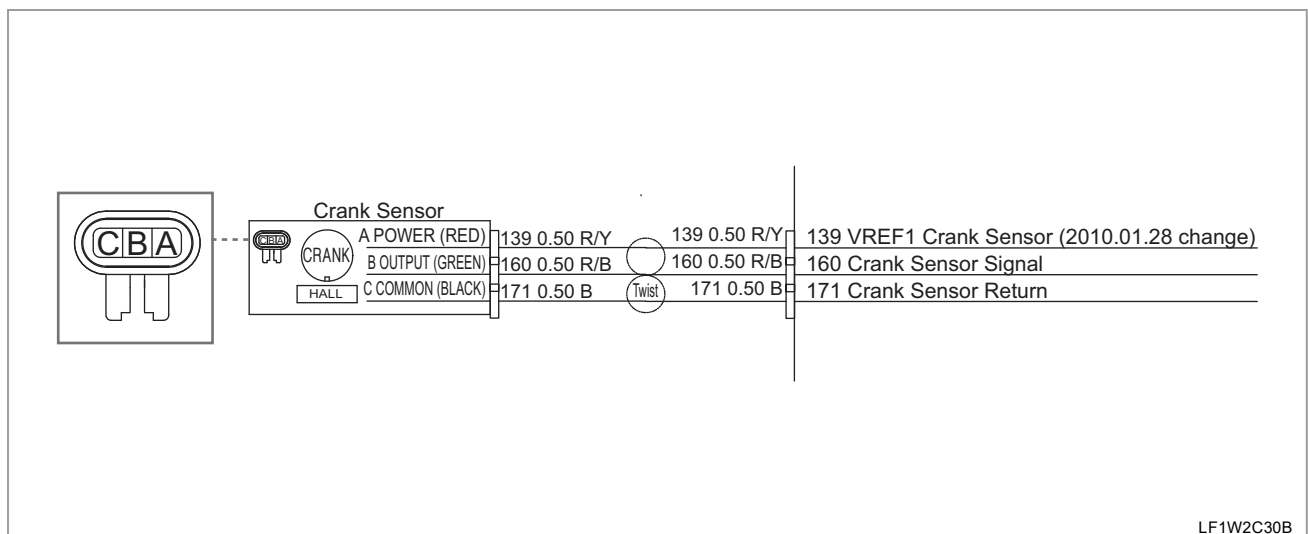

**CAM SENSOR**

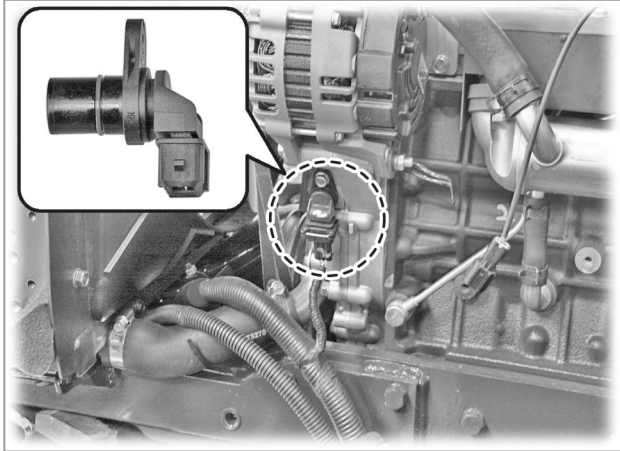
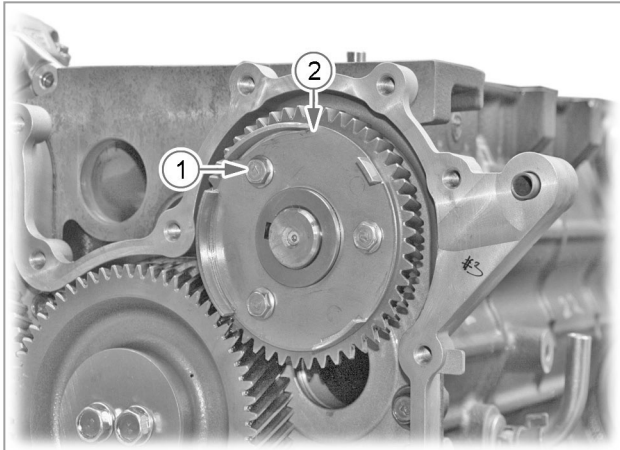
CHECK POINT	REMARK
1. CHECK SENSOR CONNECTION	
1. CHECK SENSOR CONNECTION	<p>1. Pin to Pin Check (Sensor Connector, ECU Connector, Wire Harness)                  2. Check electrical isolation.                  (*) See the Attached Wire Harness Drawings.</p>
3. CHECK CAM AND CRANK SIGNAL	<p>1. If scope is available, display the CAM and Crank signal.                  2. Signal is unstable or strange, change the sensor.</p>
4. CHECK TARGET WHEEL	<p>1. Visually check the wheel damage.                  2. Check installation position of the wheel.                  3. If problem is still present, fit new crank position sensor wheel.</p>  <p>(1) 01754-50612, Bolt, Flange (2) F6800-09051, Wheel, camshaft sensor</p>

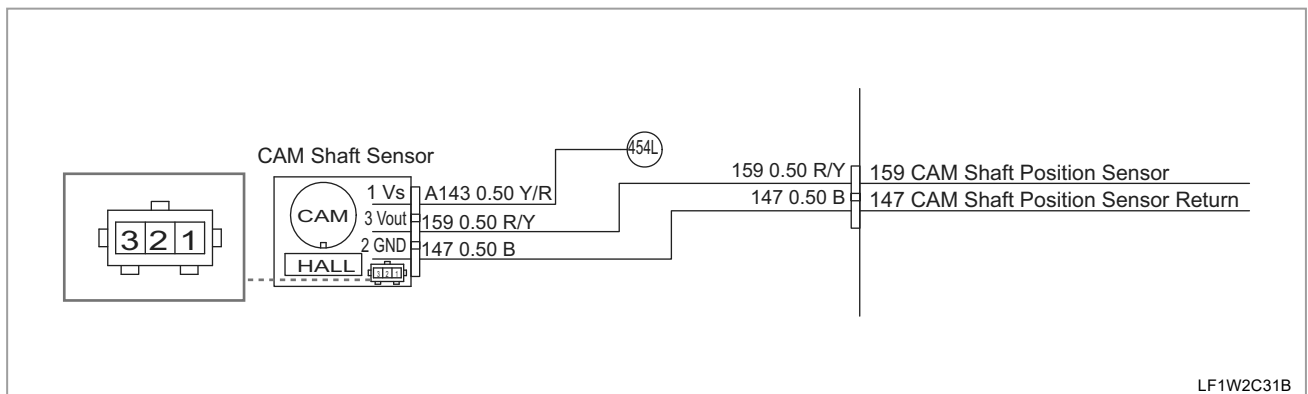

LF1W2C31B

**WATER SENSOR**

SAFETY FIRST

ENGINE

DRIVING & CHASSIS

HYDRAULIC SYSTEM

ELECTRIC SYSTEM

CABIN

INDEX

CHECK POINT	REMARK
<p>1. FUEL FILTER CHECK</p>	<div data-bbox="703 347 1326 797" data-label="Image"> </div> <p>(1) Priming Pump                      (2) Fuel Heater (3) Filter case                          (4) Water-in-fuel Sensor</p> <p>1. Check water in fuel in the pre-filter. 2. Drain water in pre-filter.</p>
<p>2. WATER SENSOR CONNECTOR / WIRE HARNESS CHECK</p>	<p>1. Pin to Pin Check (Sensor Connector, ECU Connector, Wire Harness) (* ) See the Attached Wire Harness Drawings.</p>

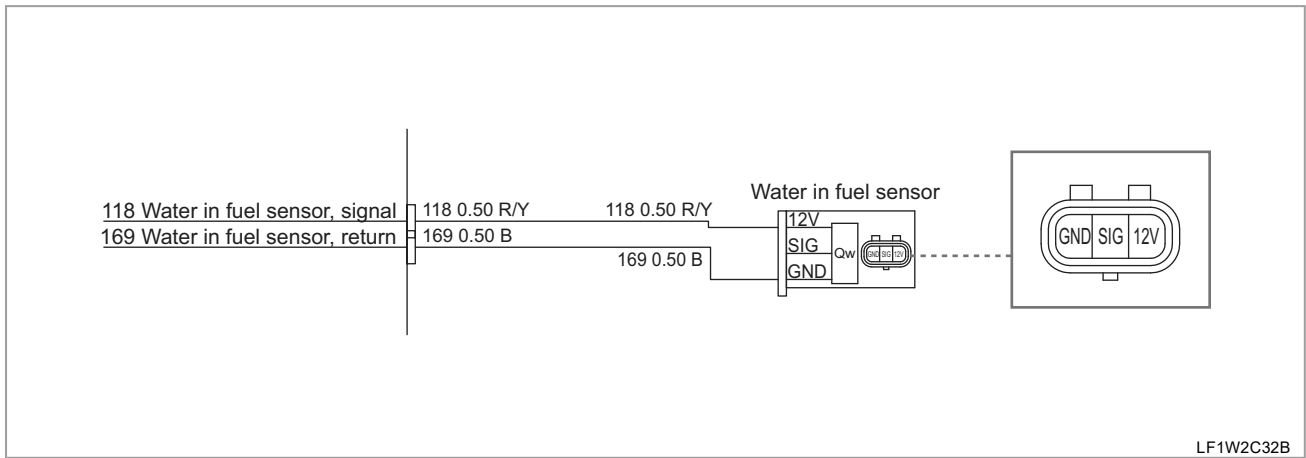



**GLOW PLUG**

CHECK POINT	REMARK
<p>1. GLOW PLUG CONNECTOR / WIRE HARNESS CHECK</p>	<div data-bbox="719 347 1342 797" data-label="Image"> </div> <p>(1) Glow plug                      (2) Injector</p> <p>1. Pin to Pin Check (Sensor Connector, ECU Connector, Wire Harness)                      (*) See the Attached Wire Harness Drawings.</p>
<p>2. GLOW PLUG WORKING TEST</p>	<p>1. Do the glow plug test using scan tool.                      2. If there is a problem, replace the glow plug.</p>

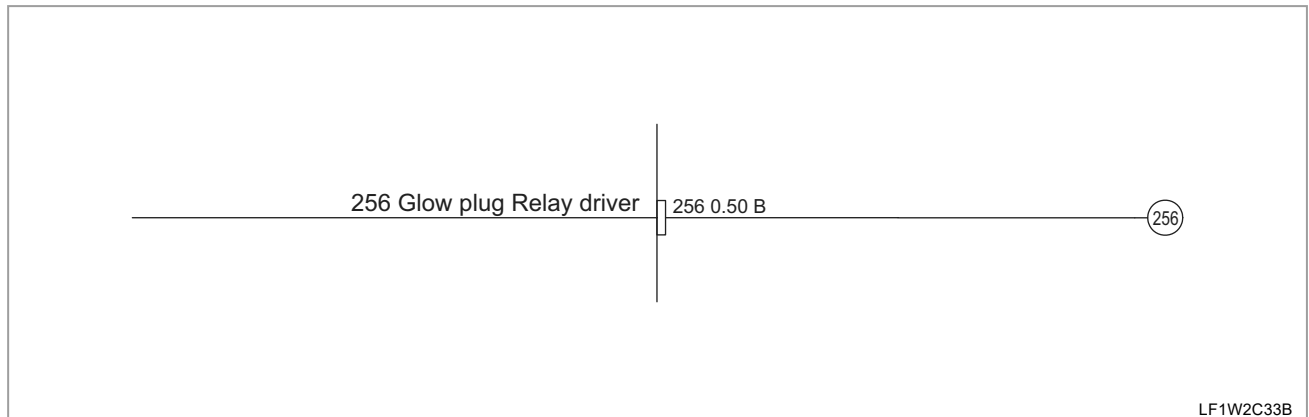

**OPEN CIRCUIT INJECTOR**

SAFETY FIRST

ENGINE

DRIVING & CHASSIS

HYDRAULIC SYSTEM

ELECTRIC SYSTEM

CABIN

INDEX

CHECK POINT	REMARK
1. INJECTOR BUZZING TEST	1. Do injector buzzing test. 2. Listen buzzing sound.
2. INJECTOR CONNECTION AND WIREHARNES CHECK	 <p>LF1W2B79A</p> 1. Key off and check the injector connection. 2. Pin to Pin Check (Injector Connector, ECU Connector, Wire Harness) (*) See the Attached Wire Harness Drawings.
3. RESISTANCE CHECK	1. It should be less than 1Ω 2. If resistance is incorrect, replace the injector.
4. CONNECTION CHECK	1. Swap the connection between 2 injectors. 2. If the same problem still presents, replace the injector. 3. Do not forget to write new individual injector code (C3I) using scan tool.

127 Fuel Injector HSDA	127 0.85 R/B	127 0.85 R/B	Injector	<table border="1"> <thead> <tr> <th>PIN NO.</th> <th>4 CYL ENG</th> <th>3 CYL ENG</th> </tr> </thead> <tbody> <tr> <td>127</td> <td>No.1 cylinder (C1)</td> <td>No.1 cylinder (C1)</td> </tr> <tr> <td>126</td> <td>No.1 cylinder (C1)</td> <td>No.1 cylinder (C1)</td> </tr> <tr> <td>103</td> <td>No.2 cylinder (C2)</td> <td>-</td> </tr> <tr> <td>125</td> <td>No.2 cylinder (C2)</td> <td>-</td> </tr> <tr> <td>151</td> <td>No.3 cylinder (C3)</td> <td>No.2 cylinder (C3)</td> </tr> <tr> <td>175</td> <td>No.3 cylinder (C3)</td> <td>No.2 cylinder (C3)</td> </tr> <tr> <td>150</td> <td>No.4 cylinder (C4)</td> <td>No.3 cylinder (C4)</td> </tr> <tr> <td>174</td> <td>No.4 cylinder (C4)</td> <td>No.3 cylinder (C4)</td> </tr> </tbody> </table>	PIN NO.	4 CYL ENG	3 CYL ENG	127	No.1 cylinder (C1)	No.1 cylinder (C1)	126	No.1 cylinder (C1)	No.1 cylinder (C1)	103	No.2 cylinder (C2)	-	125	No.2 cylinder (C2)	-	151	No.3 cylinder (C3)	No.2 cylinder (C3)	175	No.3 cylinder (C3)	No.2 cylinder (C3)	150	No.4 cylinder (C4)	No.3 cylinder (C4)	174	No.4 cylinder (C4)	No.3 cylinder (C4)
PIN NO.	4 CYL ENG	3 CYL ENG																													
127	No.1 cylinder (C1)	No.1 cylinder (C1)																													
126	No.1 cylinder (C1)	No.1 cylinder (C1)																													
103	No.2 cylinder (C2)	-																													
125	No.2 cylinder (C2)	-																													
151	No.3 cylinder (C3)	No.2 cylinder (C3)																													
175	No.3 cylinder (C3)	No.2 cylinder (C3)																													
150	No.4 cylinder (C4)	No.3 cylinder (C4)																													
174	No.4 cylinder (C4)	No.3 cylinder (C4)																													
126 Fuel Injector LSD1A	126 0.85 B	126 0.85 B	Injector C1																												
103 Fuel Injector HSDA	103 0.85 R/G	103 0.85 R/G	Injector	<table border="1"> <thead> <tr> <th>PIN NO.</th> <th>4 CYL ENG</th> <th>3 CYL ENG</th> </tr> </thead> <tbody> <tr> <td>127</td> <td>No.1 cylinder (C1)</td> <td>No.1 cylinder (C1)</td> </tr> <tr> <td>126</td> <td>No.1 cylinder (C1)</td> <td>No.1 cylinder (C1)</td> </tr> <tr> <td>103</td> <td>No.2 cylinder (C2)</td> <td>-</td> </tr> <tr> <td>125</td> <td>No.2 cylinder (C2)</td> <td>-</td> </tr> <tr> <td>151</td> <td>No.3 cylinder (C3)</td> <td>No.2 cylinder (C3)</td> </tr> <tr> <td>175</td> <td>No.3 cylinder (C3)</td> <td>No.2 cylinder (C3)</td> </tr> <tr> <td>150</td> <td>No.4 cylinder (C4)</td> <td>No.3 cylinder (C4)</td> </tr> <tr> <td>174</td> <td>No.4 cylinder (C4)</td> <td>No.3 cylinder (C4)</td> </tr> </tbody> </table>	PIN NO.	4 CYL ENG	3 CYL ENG	127	No.1 cylinder (C1)	No.1 cylinder (C1)	126	No.1 cylinder (C1)	No.1 cylinder (C1)	103	No.2 cylinder (C2)	-	125	No.2 cylinder (C2)	-	151	No.3 cylinder (C3)	No.2 cylinder (C3)	175	No.3 cylinder (C3)	No.2 cylinder (C3)	150	No.4 cylinder (C4)	No.3 cylinder (C4)	174	No.4 cylinder (C4)	No.3 cylinder (C4)
PIN NO.	4 CYL ENG	3 CYL ENG																													
127	No.1 cylinder (C1)	No.1 cylinder (C1)																													
126	No.1 cylinder (C1)	No.1 cylinder (C1)																													
103	No.2 cylinder (C2)	-																													
125	No.2 cylinder (C2)	-																													
151	No.3 cylinder (C3)	No.2 cylinder (C3)																													
175	No.3 cylinder (C3)	No.2 cylinder (C3)																													
150	No.4 cylinder (C4)	No.3 cylinder (C4)																													
174	No.4 cylinder (C4)	No.3 cylinder (C4)																													
125 Fuel Injector LSD2A	125 0.85 B	125 0.85 B	Injector C2																												
151 Fuel Injector HSDB	151 0.85 R/L	151 0.85 R/L	Injector	<table border="1"> <thead> <tr> <th>PIN NO.</th> <th>4 CYL ENG</th> <th>3 CYL ENG</th> </tr> </thead> <tbody> <tr> <td>127</td> <td>No.1 cylinder (C1)</td> <td>No.1 cylinder (C1)</td> </tr> <tr> <td>126</td> <td>No.1 cylinder (C1)</td> <td>No.1 cylinder (C1)</td> </tr> <tr> <td>103</td> <td>No.2 cylinder (C2)</td> <td>-</td> </tr> <tr> <td>125</td> <td>No.2 cylinder (C2)</td> <td>-</td> </tr> <tr> <td>151</td> <td>No.3 cylinder (C3)</td> <td>No.2 cylinder (C3)</td> </tr> <tr> <td>175</td> <td>No.3 cylinder (C3)</td> <td>No.2 cylinder (C3)</td> </tr> <tr> <td>150</td> <td>No.4 cylinder (C4)</td> <td>No.3 cylinder (C4)</td> </tr> <tr> <td>174</td> <td>No.4 cylinder (C4)</td> <td>No.3 cylinder (C4)</td> </tr> </tbody> </table>	PIN NO.	4 CYL ENG	3 CYL ENG	127	No.1 cylinder (C1)	No.1 cylinder (C1)	126	No.1 cylinder (C1)	No.1 cylinder (C1)	103	No.2 cylinder (C2)	-	125	No.2 cylinder (C2)	-	151	No.3 cylinder (C3)	No.2 cylinder (C3)	175	No.3 cylinder (C3)	No.2 cylinder (C3)	150	No.4 cylinder (C4)	No.3 cylinder (C4)	174	No.4 cylinder (C4)	No.3 cylinder (C4)
PIN NO.	4 CYL ENG	3 CYL ENG																													
127	No.1 cylinder (C1)	No.1 cylinder (C1)																													
126	No.1 cylinder (C1)	No.1 cylinder (C1)																													
103	No.2 cylinder (C2)	-																													
125	No.2 cylinder (C2)	-																													
151	No.3 cylinder (C3)	No.2 cylinder (C3)																													
175	No.3 cylinder (C3)	No.2 cylinder (C3)																													
150	No.4 cylinder (C4)	No.3 cylinder (C4)																													
174	No.4 cylinder (C4)	No.3 cylinder (C4)																													
175 Fuel Injector LSD1B	175 0.85 B	175 0.85 B	Injector C3																												
150 Fuel Injector HSDB	150 0.85 W/B	150 0.85 W/B	Injector	<table border="1"> <thead> <tr> <th>PIN NO.</th> <th>4 CYL ENG</th> <th>3 CYL ENG</th> </tr> </thead> <tbody> <tr> <td>127</td> <td>No.1 cylinder (C1)</td> <td>No.1 cylinder (C1)</td> </tr> <tr> <td>126</td> <td>No.1 cylinder (C1)</td> <td>No.1 cylinder (C1)</td> </tr> <tr> <td>103</td> <td>No.2 cylinder (C2)</td> <td>-</td> </tr> <tr> <td>125</td> <td>No.2 cylinder (C2)</td> <td>-</td> </tr> <tr> <td>151</td> <td>No.3 cylinder (C3)</td> <td>No.2 cylinder (C3)</td> </tr> <tr> <td>175</td> <td>No.3 cylinder (C3)</td> <td>No.2 cylinder (C3)</td> </tr> <tr> <td>150</td> <td>No.4 cylinder (C4)</td> <td>No.3 cylinder (C4)</td> </tr> <tr> <td>174</td> <td>No.4 cylinder (C4)</td> <td>No.3 cylinder (C4)</td> </tr> </tbody> </table>	PIN NO.	4 CYL ENG	3 CYL ENG	127	No.1 cylinder (C1)	No.1 cylinder (C1)	126	No.1 cylinder (C1)	No.1 cylinder (C1)	103	No.2 cylinder (C2)	-	125	No.2 cylinder (C2)	-	151	No.3 cylinder (C3)	No.2 cylinder (C3)	175	No.3 cylinder (C3)	No.2 cylinder (C3)	150	No.4 cylinder (C4)	No.3 cylinder (C4)	174	No.4 cylinder (C4)	No.3 cylinder (C4)
PIN NO.	4 CYL ENG	3 CYL ENG																													
127	No.1 cylinder (C1)	No.1 cylinder (C1)																													
126	No.1 cylinder (C1)	No.1 cylinder (C1)																													
103	No.2 cylinder (C2)	-																													
125	No.2 cylinder (C2)	-																													
151	No.3 cylinder (C3)	No.2 cylinder (C3)																													
175	No.3 cylinder (C3)	No.2 cylinder (C3)																													
150	No.4 cylinder (C4)	No.3 cylinder (C4)																													
174	No.4 cylinder (C4)	No.3 cylinder (C4)																													
174 Fuel Injector LSD2B	174 0.85 B	174 0.85 B	Injector C4																												

LF1W2C34B

**SHORT CIRCUIT INJECTOR**

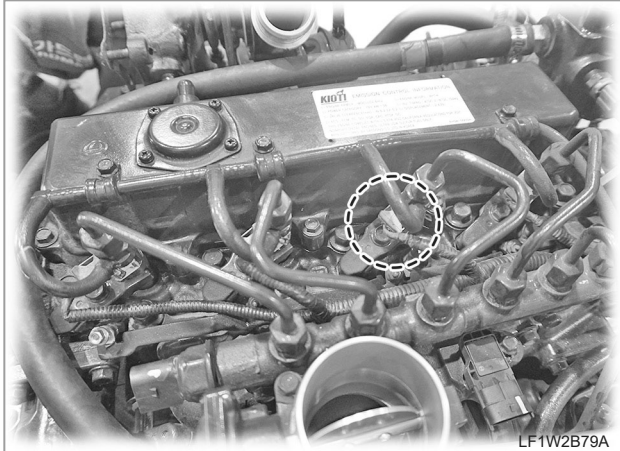
CHECK POINT	REMARK
1. INJECTOR BUZZING TEST	<ol style="list-style-type: none"> <li>Do buzzing test using scan tool.</li> <li>Listen buzzing sound.</li> </ol>
2. INJECTOR CONNECTION CHECK	<ol style="list-style-type: none"> <li>Key off and check the injector connection.</li> <li>Disconnect the injector.</li> <li>If fault disappeared, replace the injector.</li> <li>Do not forget to write new individual injector code (C3I) using scan tool.</li> </ol>
3. CHECK INTEMEDIMATE CONNECTOR	 <p style="text-align: right; font-size: small;">LF1W2B79A</p> <ol style="list-style-type: none"> <li>Disconnect the intermediate connector.</li> <li>If fault disappeared, replace the intermediate connector.</li> </ol>
4. SHORT CIRCUIT CHECK BEFORE INJECTOR	<ol style="list-style-type: none"> <li>Pin to Pin Check (Injector Connector, ECU Connector, Wire Harness)</li> <li>Check electrical isolation.</li> </ol> <p>(* ) See the Attached Wire Harness Drawings.</p>

127 Fuel Injector HSDA	127 0.85 R/B	127 0.85 R/B	Injector	<table border="1"> <thead> <tr> <th>PIN NO.</th> <th>4 CYL ENG</th> <th>3 CYL ENG</th> </tr> </thead> <tbody> <tr> <td>127 126</td> <td>No.1 cylinder (C1)</td> <td>No.1 cylinder (C1)</td> </tr> <tr> <td>103 125</td> <td>No.2 cylinder (C2)</td> <td>-</td> </tr> <tr> <td>151 175</td> <td>No.3 cylinder (C3)</td> <td>No.2 cylinder (C3)</td> </tr> <tr> <td>150 174</td> <td>No.4 cylinder (C4)</td> <td>No.3 cylinder (C4)</td> </tr> </tbody> </table>	PIN NO.	4 CYL ENG	3 CYL ENG	127 126	No.1 cylinder (C1)	No.1 cylinder (C1)	103 125	No.2 cylinder (C2)	-	151 175	No.3 cylinder (C3)	No.2 cylinder (C3)	150 174	No.4 cylinder (C4)	No.3 cylinder (C4)
PIN NO.	4 CYL ENG	3 CYL ENG																	
127 126	No.1 cylinder (C1)	No.1 cylinder (C1)																	
103 125	No.2 cylinder (C2)	-																	
151 175	No.3 cylinder (C3)	No.2 cylinder (C3)																	
150 174	No.4 cylinder (C4)	No.3 cylinder (C4)																	
126 Fuel Injector LSD1A	126 0.85 B	126 0.85 B	Injector C1																
103 Fuel Injector HSDA	103 0.85 R/G	103 0.85 R/G	Injector	<table border="1"> <thead> <tr> <th>PIN NO.</th> <th>4 CYL ENG</th> <th>3 CYL ENG</th> </tr> </thead> <tbody> <tr> <td>127 126</td> <td>No.1 cylinder (C1)</td> <td>No.1 cylinder (C1)</td> </tr> <tr> <td>103 125</td> <td>No.2 cylinder (C2)</td> <td>-</td> </tr> <tr> <td>151 175</td> <td>No.3 cylinder (C3)</td> <td>No.2 cylinder (C3)</td> </tr> <tr> <td>150 174</td> <td>No.4 cylinder (C4)</td> <td>No.3 cylinder (C4)</td> </tr> </tbody> </table>	PIN NO.	4 CYL ENG	3 CYL ENG	127 126	No.1 cylinder (C1)	No.1 cylinder (C1)	103 125	No.2 cylinder (C2)	-	151 175	No.3 cylinder (C3)	No.2 cylinder (C3)	150 174	No.4 cylinder (C4)	No.3 cylinder (C4)
PIN NO.	4 CYL ENG	3 CYL ENG																	
127 126	No.1 cylinder (C1)	No.1 cylinder (C1)																	
103 125	No.2 cylinder (C2)	-																	
151 175	No.3 cylinder (C3)	No.2 cylinder (C3)																	
150 174	No.4 cylinder (C4)	No.3 cylinder (C4)																	
125 Fuel Injector LSD2A	125 0.85 B	125 0.85 B	Injector C2																
151 Fuel Injector HSDB	151 0.85 R/L	151 0.85 R/L	Injector	<table border="1"> <thead> <tr> <th>PIN NO.</th> <th>4 CYL ENG</th> <th>3 CYL ENG</th> </tr> </thead> <tbody> <tr> <td>127 126</td> <td>No.1 cylinder (C1)</td> <td>No.1 cylinder (C1)</td> </tr> <tr> <td>103 125</td> <td>No.2 cylinder (C2)</td> <td>-</td> </tr> <tr> <td>151 175</td> <td>No.3 cylinder (C3)</td> <td>No.2 cylinder (C3)</td> </tr> <tr> <td>150 174</td> <td>No.4 cylinder (C4)</td> <td>No.3 cylinder (C4)</td> </tr> </tbody> </table>	PIN NO.	4 CYL ENG	3 CYL ENG	127 126	No.1 cylinder (C1)	No.1 cylinder (C1)	103 125	No.2 cylinder (C2)	-	151 175	No.3 cylinder (C3)	No.2 cylinder (C3)	150 174	No.4 cylinder (C4)	No.3 cylinder (C4)
PIN NO.	4 CYL ENG	3 CYL ENG																	
127 126	No.1 cylinder (C1)	No.1 cylinder (C1)																	
103 125	No.2 cylinder (C2)	-																	
151 175	No.3 cylinder (C3)	No.2 cylinder (C3)																	
150 174	No.4 cylinder (C4)	No.3 cylinder (C4)																	
175 Fuel Injector LSD1B	175 0.85 B	175 0.85 B	Injector C3																
150 Fuel Injector HSDB	150 0.85 W/B	150 0.85 W/B	Injector	<table border="1"> <thead> <tr> <th>PIN NO.</th> <th>4 CYL ENG</th> <th>3 CYL ENG</th> </tr> </thead> <tbody> <tr> <td>127 126</td> <td>No.1 cylinder (C1)</td> <td>No.1 cylinder (C1)</td> </tr> <tr> <td>103 125</td> <td>No.2 cylinder (C2)</td> <td>-</td> </tr> <tr> <td>151 175</td> <td>No.3 cylinder (C3)</td> <td>No.2 cylinder (C3)</td> </tr> <tr> <td>150 174</td> <td>No.4 cylinder (C4)</td> <td>No.3 cylinder (C4)</td> </tr> </tbody> </table>	PIN NO.	4 CYL ENG	3 CYL ENG	127 126	No.1 cylinder (C1)	No.1 cylinder (C1)	103 125	No.2 cylinder (C2)	-	151 175	No.3 cylinder (C3)	No.2 cylinder (C3)	150 174	No.4 cylinder (C4)	No.3 cylinder (C4)
PIN NO.	4 CYL ENG	3 CYL ENG																	
127 126	No.1 cylinder (C1)	No.1 cylinder (C1)																	
103 125	No.2 cylinder (C2)	-																	
151 175	No.3 cylinder (C3)	No.2 cylinder (C3)																	
150 174	No.4 cylinder (C4)	No.3 cylinder (C4)																	
174 Fuel Injector LSD2B	174 0.85 B	174 0.85 B	Injector C4																

LF1W2C34B

CXI

SAFETY FIRST

ENGINE

DRIVING & CHASSIS

HYDRAULIC SYSTEM

ELECTRIC SYSTEM

CABIN

INDEX

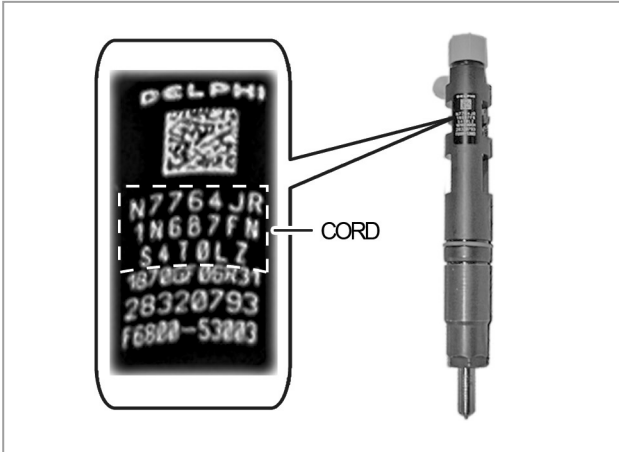
CHECK POINT	REMARK
1. REWRITE C3I CODE	 <ol style="list-style-type: none"> <li>1. Rewrite Injector Code (C3I) Code. (20 Letters)</li> <li>2. Please take care of injector position.</li> </ol>
2. CHECK POWER RELAY OPERATION	<ol style="list-style-type: none"> <li>1. Check power relay operation</li> </ol>
3. INJECTOR CONNECTOR / WIRE HARNESS CHECK	<ol style="list-style-type: none"> <li>1. Pin to Pin Check (Sensor Connector, ECU Connector, Wire Harness)</li> <li>2. Check electrical isolation.</li> </ol> <p>(* ) See the Attached Wire Harness Drawings.</p>

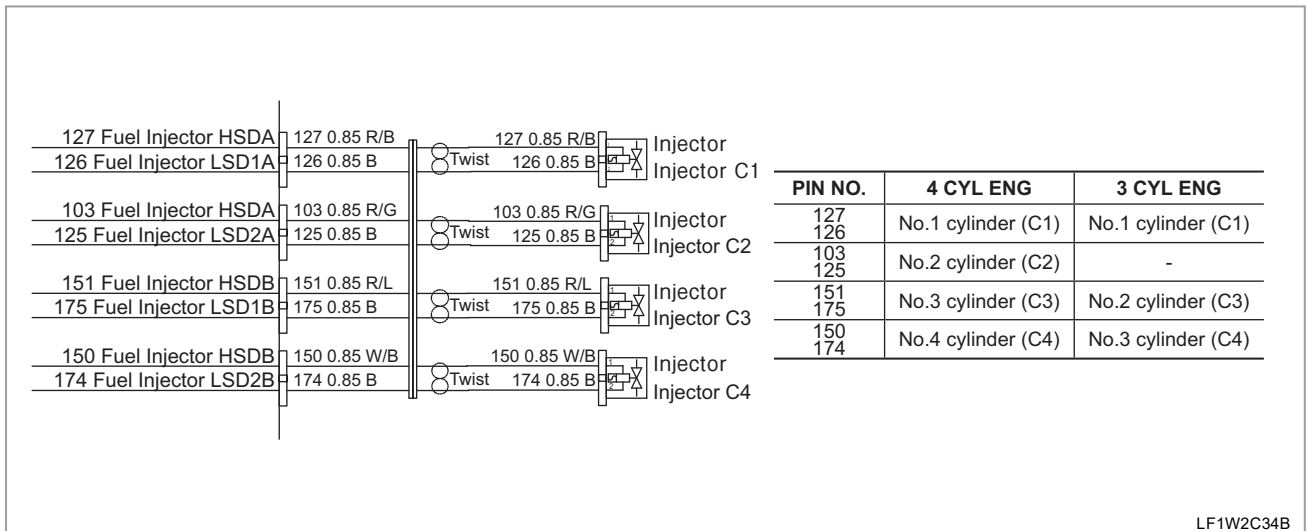

**INJECTOR BALANCING**

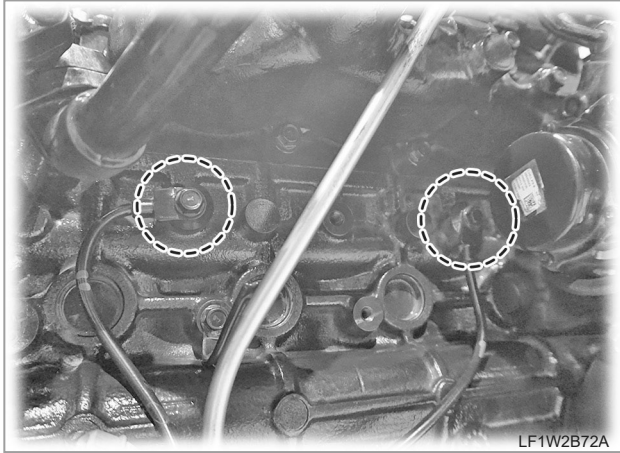
CHECK POINT	REMARK
1. CHECK DTC CODE	1. Read diagnostic code (DTC) in the scan tool.
2. REWRITE INJECTOR CODE (C3I)	2. Rewrite injector code (C3I)
3. INDIVIDUAL INJECTOR CHECK	<p>1. Check the individual injector. (Shut up test or Run up test using scan tool.)</p>  <p>2. Check the knock sensor for installation and connection. (* ) See the Attached Wire Harness Drawings.</p>
4. CHECK AIR CIRCUIT & AIR LEAK	1. Read diagnostic code (DTC) in the scan tool.

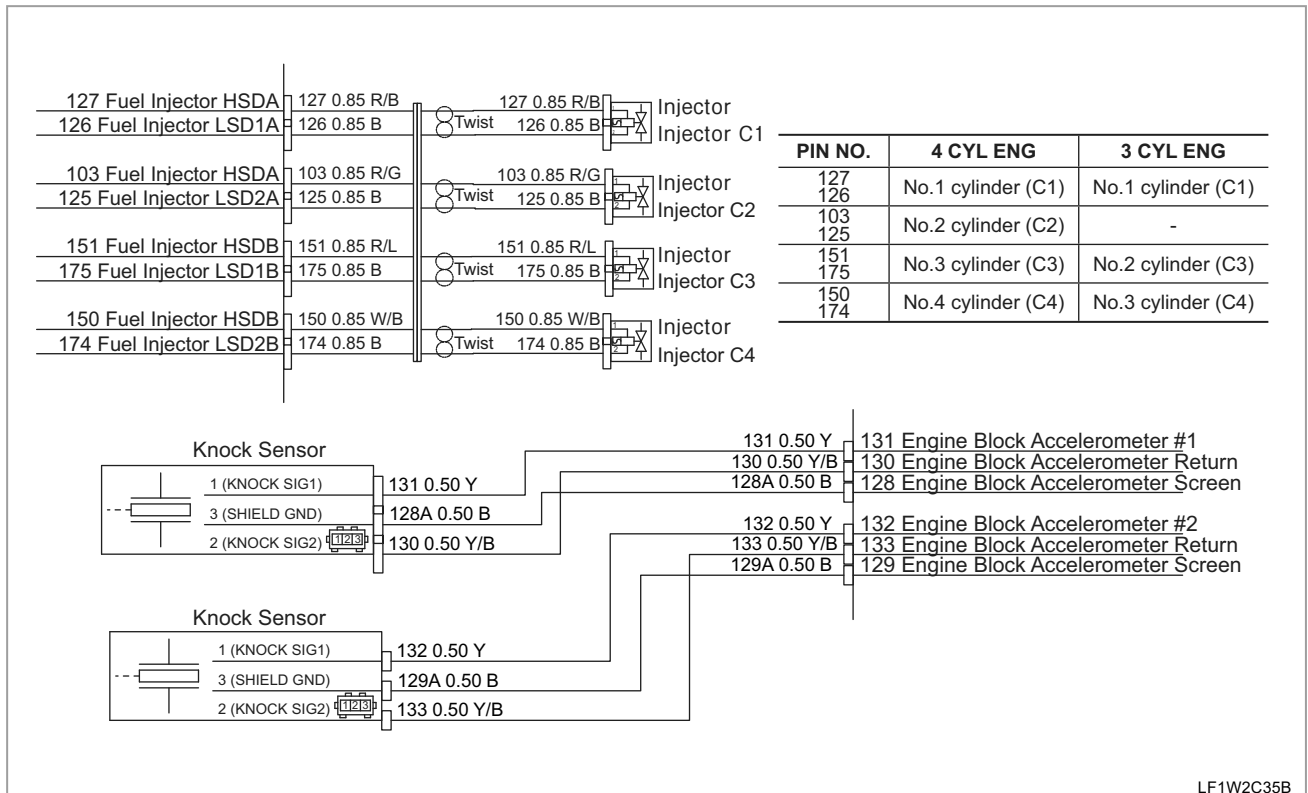

**INJECTOR TRIM**

SAFETY FIRST

ENGINE

DRIVING & CHASSIS

HYDRAULIC SYSTEM

ELECTRIC SYSTEM

CABIN

INDEX

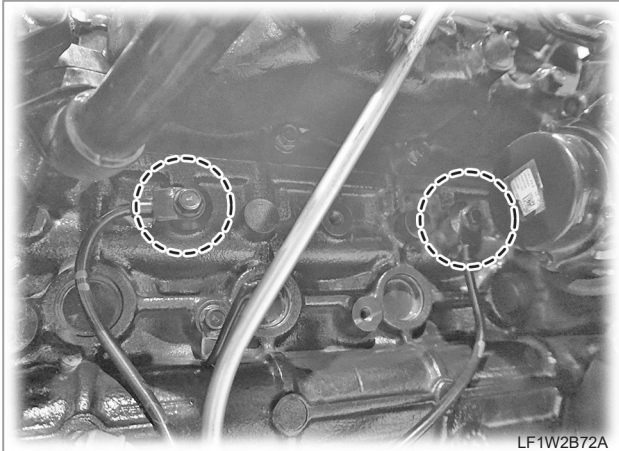
CHECK POINT	REMARK
1. NEW SOFTWARE UPGRADE	1. New software upgrade
2. REWRITE INJECTOR CODE (C3I)	2. Rewrite injector code (C3I)
3. INDIVIDUAL INJECTOR CHECK	<p>1. Check the individual injector.</p>  <p>2. Check the knock sensor for installation and connection. (*) See the Attached Wire Harness Drawings.</p>

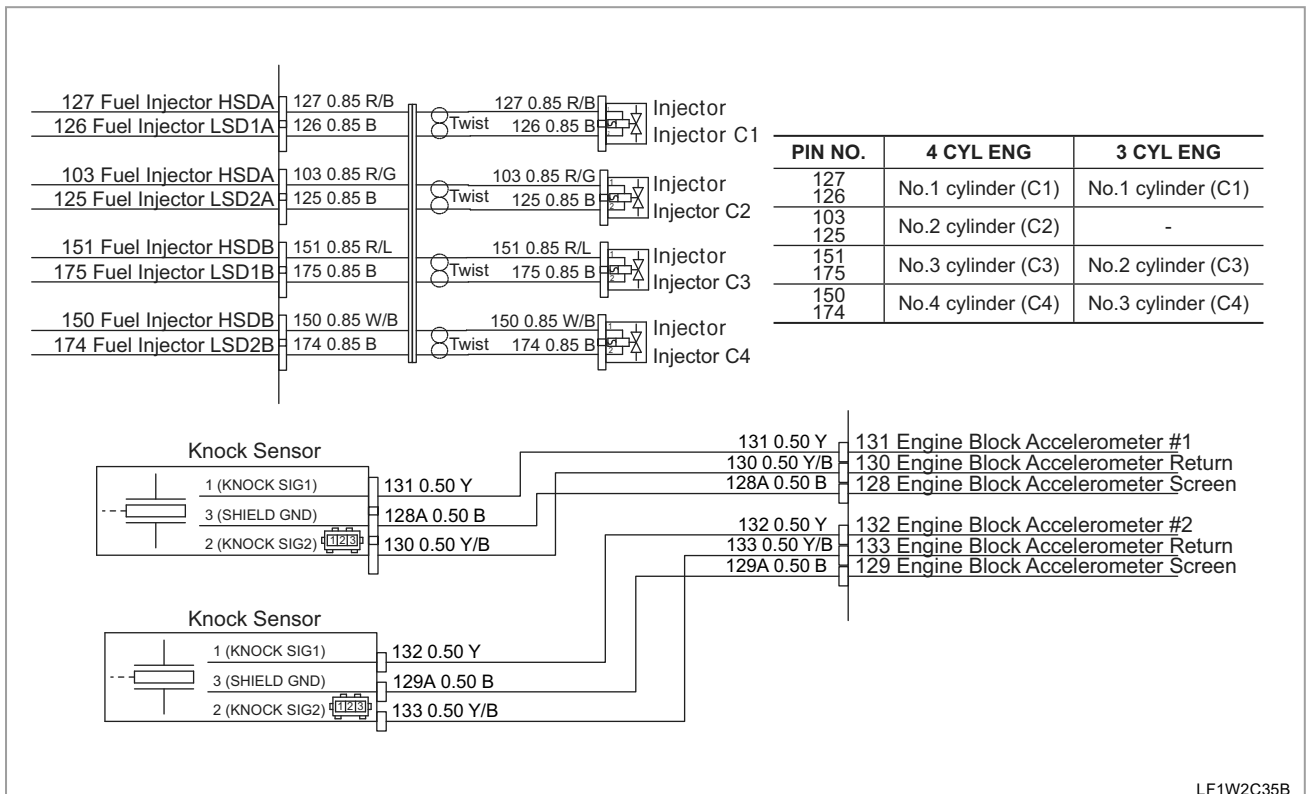

LF1W2C35B

**CYLINDER COMBUSTION TOO LOW**

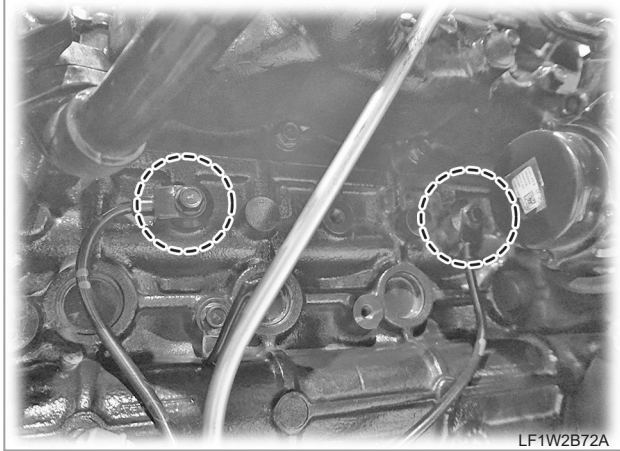
CHECK POINT	REMARK
1. CHECK DTC CODE	1. Read diagnostic code (DTC) in the scan tool.
2. REWRITE INJECTOR CODE (C3I)	1. Rewrite injector code (C3I).
3. INDIVIDUAL INJECTOR CHECK	<p>1. Check the individual injector. (Shut up test or Run up test using scan tool.)</p>  <p>2. Check the knock sensor for installation and connection. (* See the Attached Wire Harness Drawings.)</p>
4. CHECK AIR CIRCUIT & AIR LEAK	1. Read diagnostic code (DTC) in the scan tool.

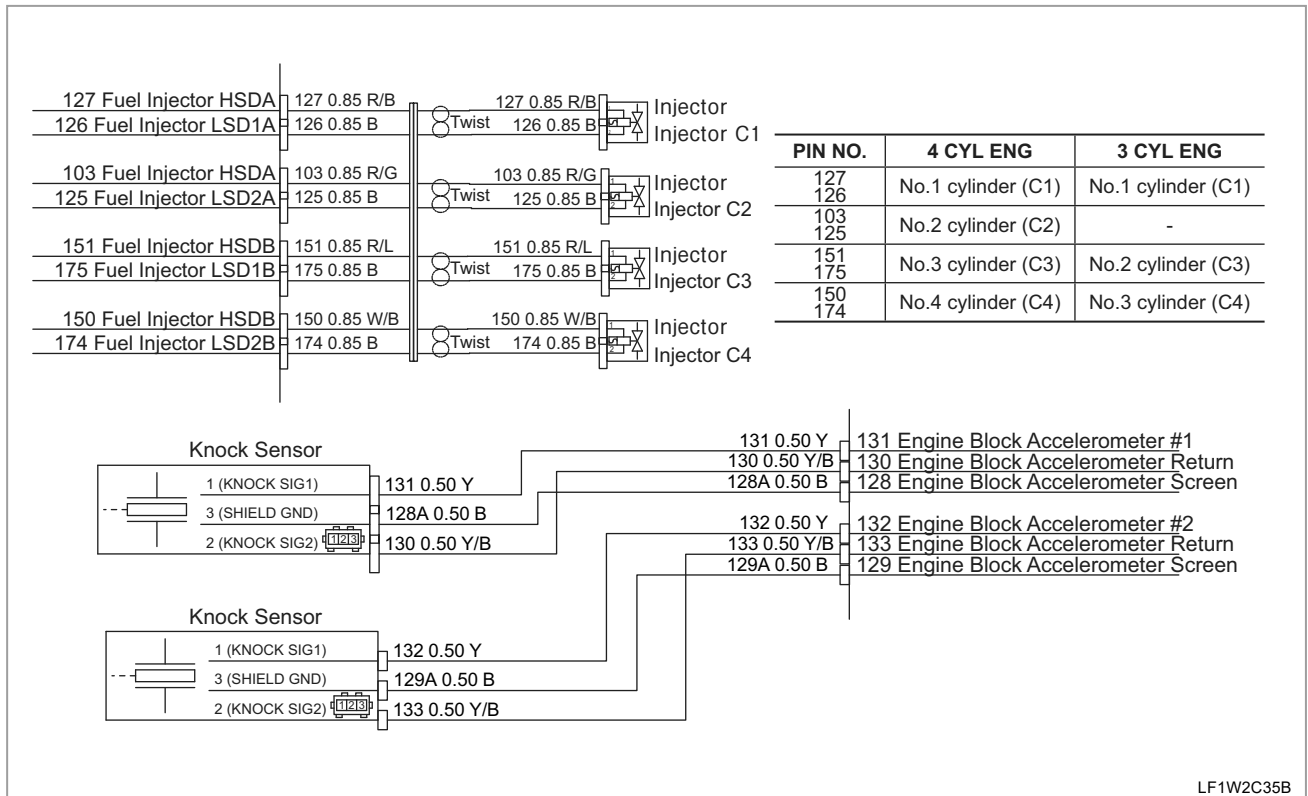

LF1W2C35B

ACV

SAFETY FIRST

ENGINE

DRIVING & CHASSIS

HYDRAULIC SYSTEM

ELECTRIC SYSTEM

CABIN

INDEX

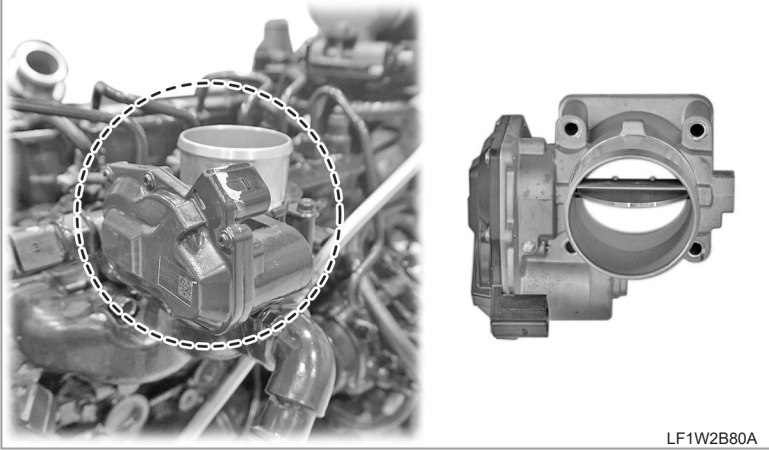
CHECK POINT	REMARK
1. ACV ACTUATOR TEST	1. Do ACV Actuator test using scan tool. (ACV position 20%, 80%, 5 times during 5 seconds)
2. ACV HARDWARE CHECK	<div data-bbox="635 443 1407 891" style="text-align: center;">  <p data-bbox="1300 869 1396 891">LF1W2B80A</p> </div> <p data-bbox="609 907 965 936">1. Check ACV hardware problem.</p>
3. ACV CONNECTOR / WIRE HARNESS CHECK	<p data-bbox="609 963 1372 992">1. Pin to Pin Check (Sensor Connector, ECU Connector, Wire Harness)</p> <p data-bbox="609 1003 906 1032">2. Check electrical isolation.</p> <p data-bbox="609 1043 1093 1072">(*) See the Attached Wire Harness Drawings.</p>

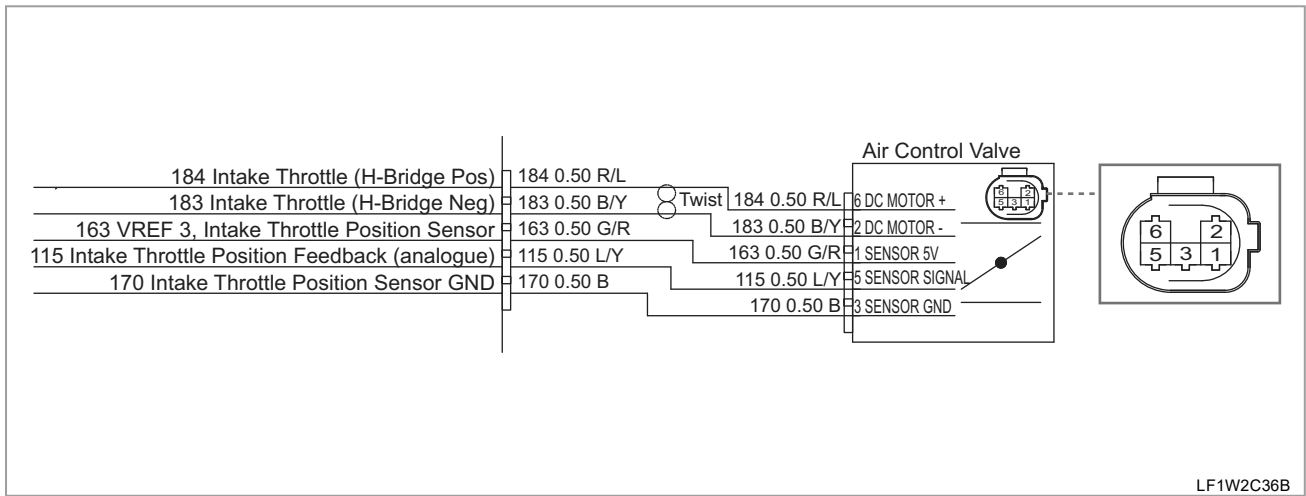



**BATTERY VOLTAGE**

CHECK POINT	REMARK
<p>1. CHECK BATTERY VOLTAGE AT KEY-ON</p>	<div data-bbox="719 349 1342 799" data-label="Image"> </div> <p>1. Check battery voltage key-on.</p>
<p>2. BATTERY CONNECTOR / WIRE HARNESS CHECK</p>	<p>1. Pin to Pin Check (Sensor Connector, ECU Connector, Wire Harness)                  2. Check resistance between vehicle chassis ground and ECU ground. (20m Ω)                  (*) See the Attached Wire Harness Drawings.</p>

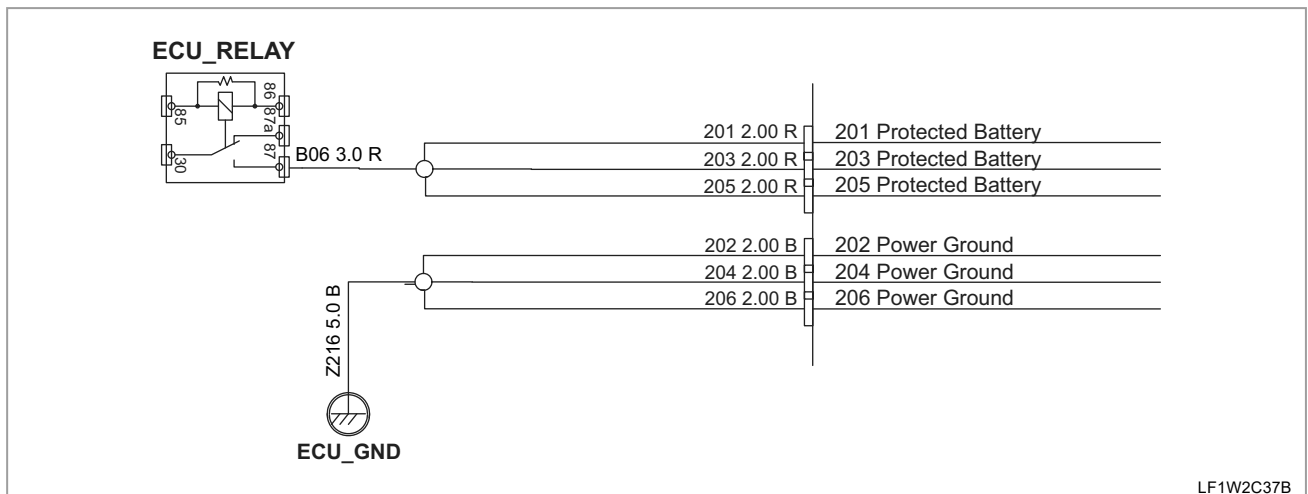

LF1W2C37B

**EGR**

SAFETY FIRST

ENGINE

DRIVING & CHASSIS

HYDRAULIC SYSTEM

ELECTRIC SYSTEM

CABIN

INDEX

CHECK POINT	REMARK
1. EGR ACTUATOR TEST	1. Do EGR Actuator test using scan tool. (EGR position 20%, 80%, 5 times during 5 seconds)
2. EGR HARDWARE CHECK	 <p>1. Check inlet / Outlet air circuit (Leak)</p>
3. EGR CONNECTOR / WIRE HARNESS CHECK	<p>1. Pin to Pin Check (Sensor Connector, ECU Connector, Wire Harness)</p> <p>2. Check electrical isolation.</p> <p>(*) See the Attached Wire Harness Drawings.</p>

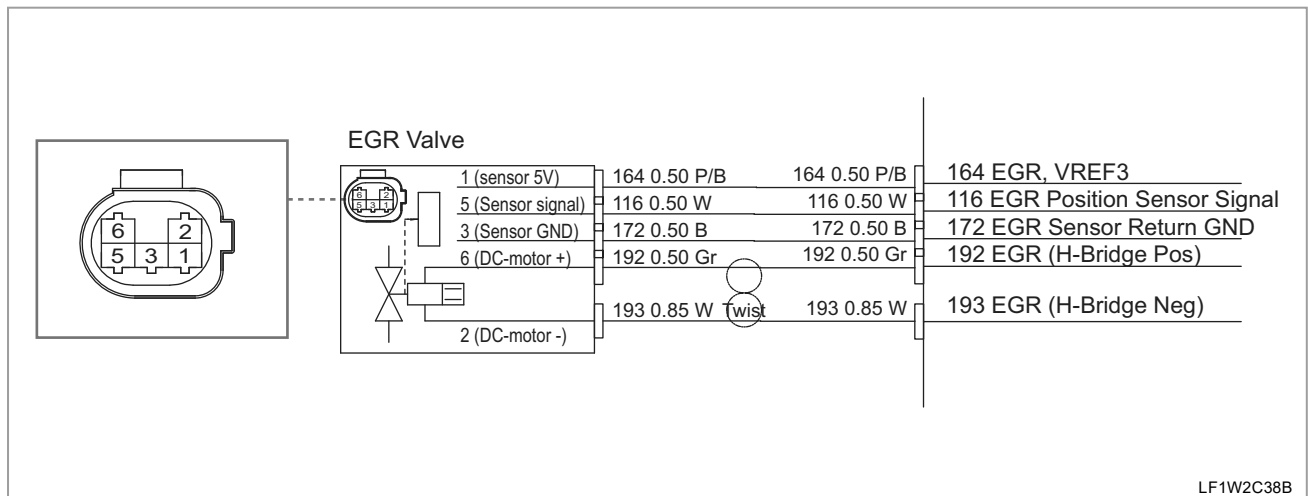

**DPF REGEN SENSOR**

CHECK POINT	REMARK
<p>1. LAMP CHECK</p>	<div data-bbox="718 336 1340 940" style="text-align: center;"> <p style="text-align: right; font-size: small;">LF1W2B83A</p> </div> <p>1. Pin to Pin Check (Sensor Connector, ECU Connector, Wire Harness)                      (*) See the Attached Wire Harness Drawings.</p>
<p>2. REPLACE LAMP</p>	<p>1. Replace lamp</p>

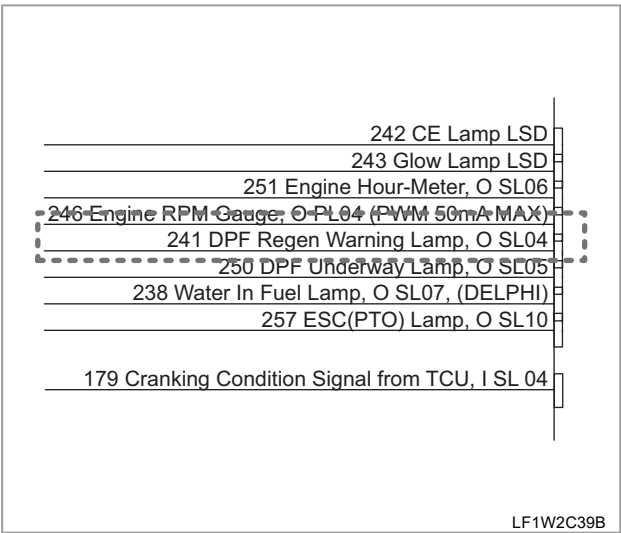

**DPF TEMP. SENSOR**

SAFETY FIRST

ENGINE

DRIVING & CHASSIS

HYDRAULIC SYSTEM

ELECTRIC SYSTEM

CABIN

INDEX

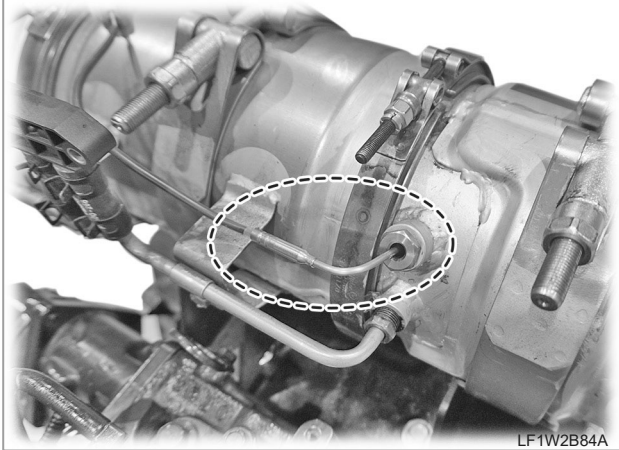
CHECK POINT	REMARK
1. SENSOR CHECK	 <p>1. Pin to Pin Check (Sensor Connector, ECU Connector, Wire Harness) (* ) See the Attached Wire Harness Drawings.</p>
2. REPLACE SENSOR	1. Replace sensor

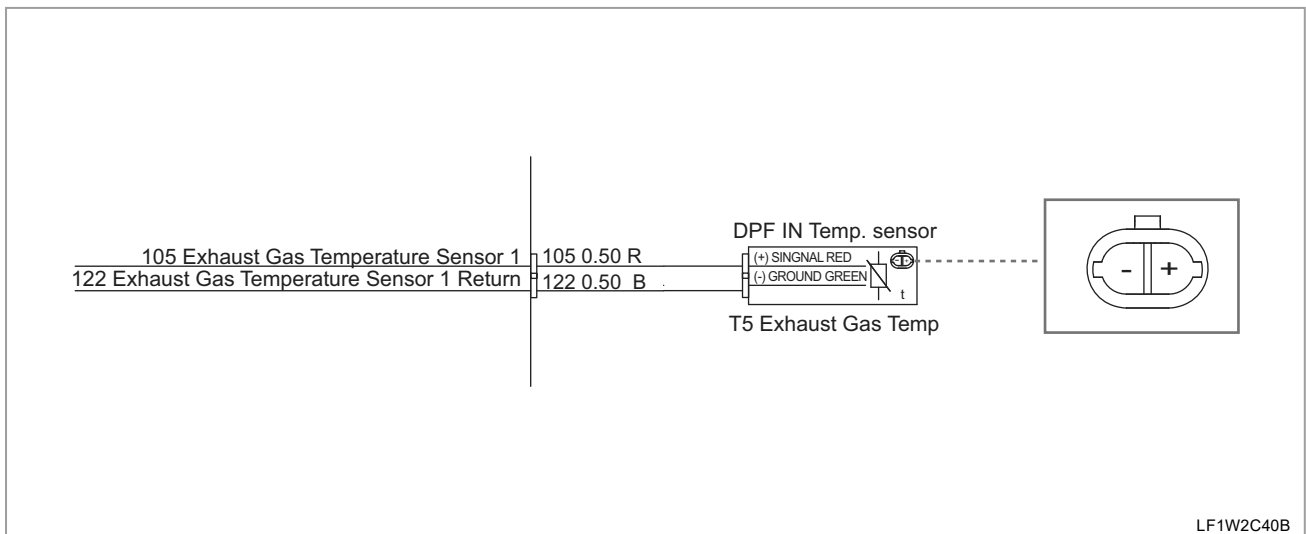

**DPF**

CHECK POINT	REMARK
1. CHECK DTC CODE	1. Read diagnostic trouble code.
2. LEAK FAULT DETECTED	<div data-bbox="719 631 1342 1081" data-label="Image"> </div> <p data-bbox="624 1099 1313 1128">1. Fix the leak on the exhaust system.(before DPF or DPF itself)</p>
3. CHECK OTHER FAULT	<p data-bbox="624 1155 1430 1214">1. First fix problem with other system.(It could have prevented regeneration of DPF causing this fault.)</p> <p data-bbox="624 1223 1390 1252">2. Pin to Pin Check (Sensor Connector, ECU Connector, Wire Harness)</p> <p data-bbox="624 1261 1107 1290">(*) See the Attached Wire Harness Drawings.</p>
4. TRY TO FILTER MANUAL REGENERATION	<div data-bbox="719 1321 1342 1771" data-label="Image"> </div> <p data-bbox="624 1789 1390 2080">                     1. Move the vehicle to safety zone                      2. Lock the brake pedal (This should be done for Manual regeneration).                      3. Warm engine (coolant over 20° C).                      4. Do Manual regeneration:                          1) Push the Manual regeneration switch during 2 seconds.                          2) Or, do Manual regeneration using scan tool.                      5. It would take about 30 ~ 40min.                      6. After regeneration successful, fault would not be raised..                 </p>

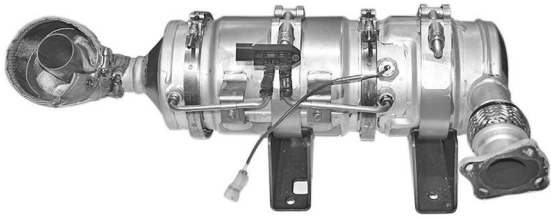
CHECK POINT	REMARK
<p>5. CHANGE THE DPF FILTER</p>	<div data-bbox="705 347 1327 797" style="text-align: center;">  <p data-bbox="1232 779 1316 797">LF1W538A</p> </div> <p data-bbox="609 815 874 846">1. Change the DPF filter.</p>

**INTAKE AIR TEMPERATURE SENSOR (T1)**

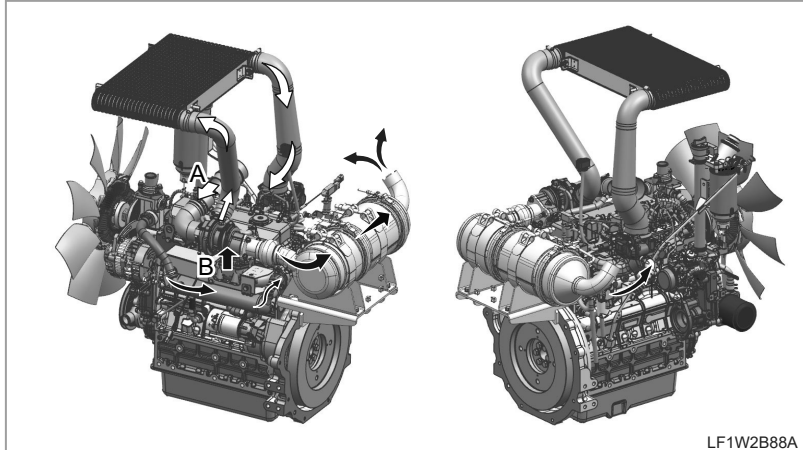
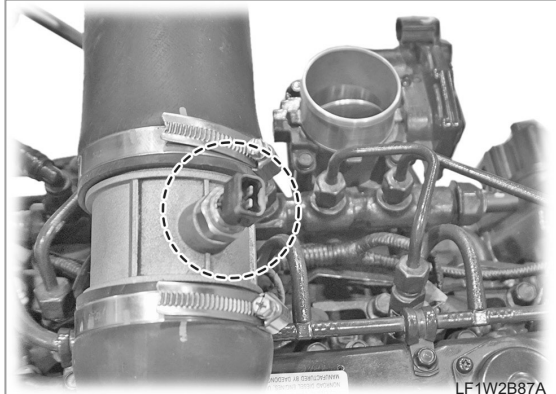
CHECK POINT	REMARK
1. CHECK AIR INLET CIRCUIT	 <p style="text-align: right;">LF1W2B88A</p> <ol style="list-style-type: none"> <li>1. Check air inlet leak in air intake system. (A)</li> <li>2. If yes, repair it.</li> </ol>
1. CHECK AIR INLET CIRCUIT	<ol style="list-style-type: none"> <li>1. Read diagnostic trouble code.</li> </ol>
3. CHECK VEXT (Supply Voltage) Fault	<ol style="list-style-type: none"> <li>1. Disconnect sensor one by one checking if disappear to find which one is faulty. (Problem with one of the sensors causing loss of supply voltage)</li> <li>2. If none is found faulty, check short circuit or isolation of Vext lines of harness.</li> </ol>
4. ECU CONNECTOR / WIRE HARNESS CHECK	 <p style="text-align: right;">LF1W2B87A</p> <ol style="list-style-type: none"> <li>1. Pin to Pin Check (Sensor Connector, ECU Connector, Wire Harness)</li> <li>2. Check electrical isolation.</li> </ol> <p>(*) See the Attached Wire Harness Drawings.</p>

