

SERVICE MANUAL

(Tier 3)



HR70/110/120/140C-9

Overview: Chapters

- **Chapter 1: Machine designation, manufacturer, serial number and measuring units**
- **Chapter 2: Technical specifications Compaction rollers**
- **Chapter 3: Operating elements & displays**
- **Chapter 4: Options**
- **Chapter 5: Maintenance**
- **Chapter 6: Diesel engine and hydraulic system**
- **Chapter 7: Drum drive and rear axle**
- **Chapter 8: Antrieb vibration system**
- **Chapter 9: Electrical system**
- **Chapter 10: Steering system and articulated pendulum joint**
- **Chapter 11: Towing**

Table of contents

- **Chapter 1: Machine designation, manufacturer, serial number and measuring units**

1.1 Machine designation, intended use and manufacturer	1-2
1.1.1 Manufacturer	1-2
1.1.1A Distributer	1-2
1.1.2 HR70C-9: Type plate and serial number.....	1-3
1.1.3 HR110C-9/HR120C-9/HR140C-9: Type plate and serial number	1-4
1.1.4 Legal measuring units	1-5
1.1.5 Tightening torques (in Nm) for screws & bolts.....	1-6

- **Chapter 2: Technical specifications Compaction rollers**

2.1 Technical specifications	2-2
2.1.1 Operating data	2-2
2.1.2 HR70C-9: Dimensions	2-4
2.1.3 HR110C-9/HR120C-9/HR140C-9: Dimensions	2-5
2.1.4 Roll-over protection system	2-6

- **Chapter 3: Operating elements & displays**

3.1 Control elements and displays	3-2
--	------------



- 3.1.1 Displays on the dashboard 3-3
- 3.1.2 Dashboard: Displays related to roller operation 3-4
- 3.1.3 Steering column switches 3-4
- 3.1.4 HR70C-9: Control lever (joystick) and panel of switches in the right armrest 3-5
- 3.1.5 HR110C-9/HR120C-9/HR140C-9: Control lever (joystick) and panel of switches in the right armrest 3-6
- 3.2 Compaction roller functions 3-7**
 - 3.2.1 HR70C-9: Functions of the hydraulic HA control 3-7
 - 3.2.2 HR110C-9/HR120C-9/HR140C-9: Functions of the hydraulic HA control 3-8
 - 3.2.3 Maximum gradeability of the compaction rollers 3-9
- Chapter 4: Options**
 - 4.1 Converting from a smooth roller drum to a pad foot roller drum (Optional feature) 4-2**
 - 4.1.1 Mounting the pad foot segments on a smooth roller drum 4-3
 - 4.1.2 Mounting the pad foot segments 4-4
 - 4.1.3 Mounting the scrapers for the pad foot roller drum 4-6
 - 4.2 Compaction measurement system (Optional feature) 4-7**
 - 4.2.1 Variants of the compaction measurement system 4-8
 - 4.2.2 Installing the sensors and connecting them to the compaction measurement system 4-10
 - 4.2.3 Installing the speed sensor at the axle 4-11
 - 4.2.4 Establishing the connections at the compaction measurement system 4-13
 - 4.3 ECO Speed Function (Optional feature) 4-14**
 - 4.3.1 Activating and deactivating the ECO Speed function 4-14

4.3.2 Overview: Components of the ECO Speed system.....	4-15
---	------

• **Chapter 5: Maintenance**

5.1 Maintenance measures	5-2
5.1.1 Safety instructions referring to maintenance work.....	5-2
5.1.2 Safety precautions to be taken prior to maintenance work	5-3
5.1.3 HR70C-9: Maintenance overview	5-4
5.1.4 HR110C-9/HR120C-9/HR140C-9: Maintenance overview	5-5
5.1.5 Maintenance instructions referring to the initial operation	5-6
5.1.6 Instruction and demonstration at the machine	5-7
5.1.7 Check list: 1st inspection after 50 operating hours.....	5-9
5.1.8 Table of lubricants.....	5-10
5.2 Maintenance work	5-11
5.2.1 Maintenance work related to the Diesel engine	5-11
5.2.2 Hydraulic system	5-15
5.2.3 Rear axle	5-17
5.2.4 HR70C-9: Maintenance work at the drum drive.....	5-20
5.2.5 HR110C-9/HR120C-9/HR140C-9: Maintenance work at the drum drive.....	5-21
5.2.6 Maintenance work at the vibration drive	5-22
5.2.7 Maintenance work at the ventilation system.....	5-23
5.2.8 Note regarding maintenance work related to the electrical installation	5-23

5.2.9	HR70C-9: Perkins Diesel engine maintenance schedule	5-24
5.2.10	HR110C-9/HR120C-9/HR140C-9: Deutz Diesel engine maintenance schedule	5-25
5.3	Tires at the rear axle.....	5-26
5.3.1	Water filling in the tires of the rear axle	5-26
5.3.2	Emptying the tires.....	5-27
5.3.3	Filling procedure: Using the “Hanauer Maus”	5-28
5.3.4	Checking the tire inflation pressure	5-29
5.3.5	Mounting the tires.....	5-29
•	Chapter 6: Diesel engine and hydraulic system	
6.1	Diesel engine	6-2
6.1.1	Technical specifications Diesel engine	6-2
6.1.2	Maintenance overview Diesel engine	6-2
6.2	Hydraulic system.....	6-3
6.2.1	Technical specifications hydraulic system	6-3
6.2.2	Maintenance work hydraulic system.....	6-3
6.2.3	Hydraulic circuit diagram: Entire hydraulic system HR70C-9	6-4
6.2.4	Hydraulic circuit diagram: Entire hydraulic system HR110C-9/HR120C-9/HR140C-9	6-5
•	Chapter 7: Drum drive and rear axle	
7.1	Drum and rear axle.....	7-2
7.1.1	Technical specifications drum.....	7-2



7.1.2	Technical specifications rear axle	7- 2
7.1.3	Overview: Drum	7- 3
7.1.4	Overview Drive Hydraulics Drum HR70C-9 DIR110C-9 DIR120C-9 DIR140C-9 Á.....	7- 4
7.1.5	Overview Drive Hydraulics Rear Axle HR70C-9 DIR110C-9 DIR120C-9 DIR140C-9 Á.....	7- 5
7.1.6	HR70C-9: Drive unit - Sequence of functions	7- 6
7.1.7	HR110C-9 DIR120C-9 DIR140C-9: Drive unit - Sequence of functions..... È.....	7- 7
7.1.8	Trouble shooting: What to do if the compaction roller does not start	7- 8
7.1.9	Speeds, hydraulic measuring and adjustment values for compaction rollers.....	7-10
7.1.10	Overview: Adjustments at the oil pressure pump of the drum drive	7-10
7.1.11	Overview: Adjustments at the oil pressure pump of the drum drive.....	7-11
7.2	Installing & dismantling the drum.....	
7.2.1	Preparing the drum for repair work.....	7-13
7.2.1.1	Overview Drum.....	7-14
7.2.2	Removing the drum	7-17
7.2.3	Dismantling the drum.....	7-18
7.2.4	Removing the bearing	7-20
7.2.5	Installing the bearing	7-21
7.2.6	Assembling the drum	7-23
7.2.7	Installing the drum	7-27

• **Chapter 8: Drive unit of the vibration system**

8.1 Vibration system	8- 2
8.1.1 Technical specifications	8- 2
8.1.2 Overview: Vibration system	8- 3
8.1.3 Overview: Vibration hydraulics	8- 4
8.1.4 Sequence of function - Vibration mode.....	8- 5
8.1.5 Trouble shooting: What to do if the vibration does not start	8- 6
8.2 Engine speeds, hydraulic measuring and default values	8- 7
8.2.1 Overview: Measuring points of the vibration hydraulics and required operating conditions	8- 8
8.2.2 Overview: Adjustments at the oil pressure pump (vibration)	8- 9
8.3 Using a sirometer	8-10

• **Chapter 9: Electrical system**

9.1 Electrical system	9- 2
9.1.1 Maintenance work referring to the electrical system	9- 2
9.1.2 Overview: Electrical system HR70C-9	9- 3
9.1.3 Overview: Electrical system HR110C-9HR120C-9HR140C-9.....	9- 4
9.1.4 Printed circuit board, fuses and relays	9- 5

Electric circuit diagrams	9-10
--	-------------



- **Chapter 10: Steering system & Articulated pendulum joint**

10.1 Steering system and articulated pendulum joint	10-2
10.2 Steering system	10-2
10.2.1 Technical specifications	10-2
10.2.2 Overview: Steering hydraulics and components	10-3
10.3 Articulated pendulum joint	10-4
10.3.1 Installing and dismantling the articulated pendulum joint	10-5

- **Kapitel 11: Towing the compaction roller**

11.1 Towing the compaction roller	11- 2
11.1.1 Safety instructions referring to towing the compaction roller	11- 2
11.1.2 Precautionary measures to be taken prior to towing	11- 3
11.1.3 Carrying out the towing process	11- 4
11.1.4 After the towing process	11- 5



Chapter 1

Machine designation, manufacturer, serial number and measuring units

Contents

This chapter provides you with information about:

- the machine type, the manufacturer and
 - the serial number & the type plate
 - measuring units and conversion tables
- 

1.1 Machine designation, intended use and manufacturer

Designation:	Types:
HYUNDAI compaction roller	HR70C-9DIR110C-9DIR120C-9DIR140C-9
Purpose of use:	
The HYUNDAI compaction rollers serve to compact soil.	
Intended use:	
The HYUNDAI compaction roller may only be used for the purposes and work mentioned in the operating manual. Any other use of the machine for further purposes is considered as misuse and is not permitted.	

1.1.1 Manufacturer

Name of manufacturer:
ATLAS WEYHAUSEN F. Weyhausen GmbH & Co. KG Maschinenfabrik
Address:
27793 Wildeshausen, Visbeker Straße 35 (Germany)
Contact:
Phone: +49 (0) 4431 981 - 0 Fax: +49 (0) 4431 981 - 139 E-Mail: info@f-veyhausen.de Web: www.atlaswalzen.com

1.1.1A Distributor

Distributor, Address
Hyundai Heavy Industries co., Ltd. 1000, Bangeojin sunhwan-doro, Dong-Gu, Ulsan, 682-792, Korea

1.1.2 HR70C-9: Type plate and serial number



Type plate cabin



Type plate labelling

2 5 0 1 X X X X 1 2 3 4 5 6

The serial number (1) features reference numbers **X** in order to identify specific equipment, the serial number (1) and the drum type. The serial number can be found on the type plate (2) on the right side below the cabin. In addition, it has been punched into the basic frame.

Serial number key:

2 5 0 1 X X X X 1 2 3 4 5 6 **B1** **B2**

Type:

HR70C-9

1

Current serial number

Smooth drum

Pad foot drum

Engine output:

61.5 kW

2200 min⁻¹

1

2-stage drive:

HA Standard

1

Cabin

Standard

0

Canopy

1

1.1.3 HR110C-9/HR120C-9/HR140C-9: Type plate and serial number



Type plate cabin



Type plate labelling

2 6 0 1 X X X X 1 2 3 4 5 6

The serial number (1) features reference numbers **X** in order to identify specific equipment, the serial number (1) and the drum type. The serial number can be found on the type plate (2) on the right side below the cabin.

In addition, it has been punched into the basic frame.

Serial number key:

2 6 0 1 X X X X 1 2 3 4 5 6 B1 B2

Type:

HR110C-9

1

HR120C-9

2

HR140C-9

4

Engine output:

96 kW 2200 min⁻¹

1

103 kW 2400 min⁻¹

2

4-stage drive:

HA Standard

1

HA & ECO

2

Cabin

Standard

0

Canopy

1

Current serial number

Smooth drum

Pad foot drum

1.1.4 Legal measuring units

Measuring system:	Metric	Inch
	25.40 mm	1 in (inch)
	1 kg	2.205 lbs
	9.81 Nm (1 kpm)	7.233 lbf x ft (pound-force foot)
	1.356 Nm (0.138 kpm)	1 lbf x ft (pound-force foot)
	1 kg / cm	5.560 lbs
	1 bar (1.02 kp/cm²)	14.233 psi (pound-force per square inch lb/in²)
	0.070 bar (0.071 kp/cm²)	1 psi (lb/in²)
	1 liter	0.264 Gallon (Imp.) / 0.220 Gallon (US)
	3.785 liters	1 Gallon (US)
	4.456 liters	1 Gallon (Imp.)
	1609.344 m	1 mile
	0° C (Celsius)	+ 32° F (Fahrenheit) / 273.15 Kelvin

1.1.5 Tightening torques (in Nm) for screws & bolts

Standard metric ISO thread DIN 13, sheet 13			
Dimensions	8.8	10.9	12.9
M4	2.8	4.1	4.8
M5	5.5	8.1	9.5
M6	9.5	14	16.5
M7	15	23	28
M8	23	34	40
M10	46	68	79
M12	79	115	135
M14	125	185	215
M16	195	280	330
M18	280	390	460
M20	390	560	650
M22	530	750	880
M24	670	960	1100
M27	1000	1400	1650
M30	1350	1900	2250
M33	1850	2600	3000
M36	2350	3300	3900
M39	3000	4300	5100

Standard metric ISO thread DIN 13, sheet 13

Dimensions	8.8	10.9	12.9
M 8 x 1	24	36	43
M 9 x 1	36	53	62
M10 x 1	52	76	89
M10 x 1.25	49	72	84
M12 x 1.25	87	125	150
M12 x 1.5	83	120	145
M12 x 1.5	135	200	235
M14 x 1.5	205	300	360
M16 x 1.5	310	440	520
M18 x 1.5	290	420	490
M20 x 1.5	430	620	720
M22 x 1.5	580	820	960
M24 x 1.5	760	1100	1250
M24 x 2	730	1050	1200
M27 x 1.5	1100	1600	1850
M27 x 2	1050	1500	1800
M30 x 1.5	1550	2200	2550
M30 x 2	1500	2100	2500
M33 x 1.5	2050	2900	3400
M33 x 2	2000	2800	3300
M36 x 1.5	2700	3800	4450
M36 x 3	2500	3500	4100
M39 x 1.5	3450	4900	5700
M39 x 3	3200	4600	5300



NOTE!

Friction coefficient: μ total = 0.12 for screws and nuts without post-treatment as well as phosphated nuts. **Tighten by hand!**



Chapter 2

Technical specifications Compaction rollers

Contents

This chapter provides you with information about:

- the technical specifications of the compaction rollers and the Diesel engines
 - their dimensions
 - the fill levels of the fluids and lubricants
- 

2.1 Technical specifications

2.1.1 Operating data

with smooth drum	HR70-9	HR110-9	HR120-9	HR140-9
General data:				
Service weight	7100 kg	11200 kg	12000 kg	13900 kg
Axle load, front	3800 kg	6100 kg	6900 kg	8000 kg
Axle load, rear	3300 kg	5100 kg	5100 kg	5900 kg
Compaction performance:				
Static linear load	22.40 kg/cm	29.00 kg/cm	32.80 kg/cm	38.00 kg/cm
Amplitude high / low	1.8 / 0.8 mm	1.8 / 0.8 mm	1.8 / 0.6 mm	1.9 / 0.7 mm
Frequency at high / low amplitude	30 / 40 Hz	30 / 38 Hz	30 / 40 Hz	30 / 40 Hz
Centrifugal force at high / low ampl.	120 / 90 kN	220 / 150 kN	240 / 140 kN	280 / 180
Drum:				
Drum width	1700 mm	2100 mm	2100 mm	2100 mm
Drum diameter	1250 mm	1500 mm	1500 mm	1500 mm
Drum thickness	20 mm	25 mm	30 mm	30 mm
Drive / Transmission:				
Speed	0-10 km/h	0-12.5 km/h	0-12.5 km/h	0-12.5 km/h
Angular movement	+/- 12°	+/- 12°	+/- 12°	+/- 12°
Gradeability with / without vibration	45% / 50%	43% / 48%	45% / 48%	40% / 45%
Noise level:				
Sound power level L_{WA}	106 dB	106 dB	106 dB	106 dB

with pad foot drum	HR70C-9	HR110C-9	HR120C-9	HR140C-9
General data:				
Service weight	7250 kg	11200 kg	12000 kg	13900 kg
Axle load, front	4200 kg	6100 kg	6900 kg	8000 kg
Axle load, rear	3150 kg	5100 kg	5100 kg	5900 kg
Compaction performance:				
Static linear load	/	/	/	/
Amplitude high / low	1.8 / 0.8 mm	1.8 / 0.8 mm	1.8 / 0.6 mm	1.9 / 0.7 mm
Frequency at high / low amplitude	30 / 40 Hz	30 / 38 Hz	30 / 40 Hz	30 / 40 Hz
Centrifugal force at high / low ampl.	120 / 90 kN	220 / 150 kN	240 / 140 kN	280 / 180
Drum:				
Drum width	1700 mm	2100 mm	2100 mm	2100 mm
Drum diameter	11400 mm	1390 mm	1390 mm	1390 mm
Drum thickness	15 mm	25 mm	30 mm	30 mm
Drive / Transmission:				
Speed	0-10 km/h	0-12.5 km/h	0-12.5 km/h	0-12.5 km/h
Angular movement	+/- 12°	+/- 12°	+/- 12°	+/- 12°
Gradeability with / without vibration	45% / 50%	43% / 48%	48% / 52%	40% / 45%
Noise level:				
Sound power level L_{WA}	106 dB	106 dB	106 dB	106 dB

with pad foot drum	HR70C-9	HR110C-9	HR120C-9	HR140C-9
General data:				
Service weight	7250 kg	11200 kg	12000 kg	13900 kg
Axle load, front	4200 kg	6100 kg	6900 kg	8000 kg
Axle load, rear	3150 kg	5100 kg	5100 kg	5900 kg
Compaction performance:				
Static linear load	/	/	/	/
Amplitude high / low	1.8 / 0.8 mm	1.8 / 0.8 mm	1.8 / 0.6 mm	1.9 / 0.7 mm
Frequency at high / low amplitude	30 / 40 Hz	30 / 38 Hz	30 / 40 Hz	30 / 40 Hz
Centrifugal force at high / low ampl.	120 / 90 kN	220 / 150 kN	240 / 140 kN	280 / 180
Drum:				
Drum width	1700 mm	2100 mm	2100 mm	2100 mm
Drum diameter	11400 mm	1390 mm	1390 mm	1390 mm
Drum thickness	15 mm	25 mm	30 mm	30 mm
Drive / Transmission:				
Speed	0-10 km/h	0-12.5 km/h	0-12.5 km/h	0-12.5 km/h
Angular movement	+/- 12°	+/- 12°	+/- 12°	+/- 12°
Gradeability with / without vibration	45% / 50%	43% / 48%	48% / 52%	40% / 45%
Noise level:				
Sound power level L_{WA}	106 dB	106 dB	106 dB	106 dB

2.1.2 HR70C-9: Dimensions

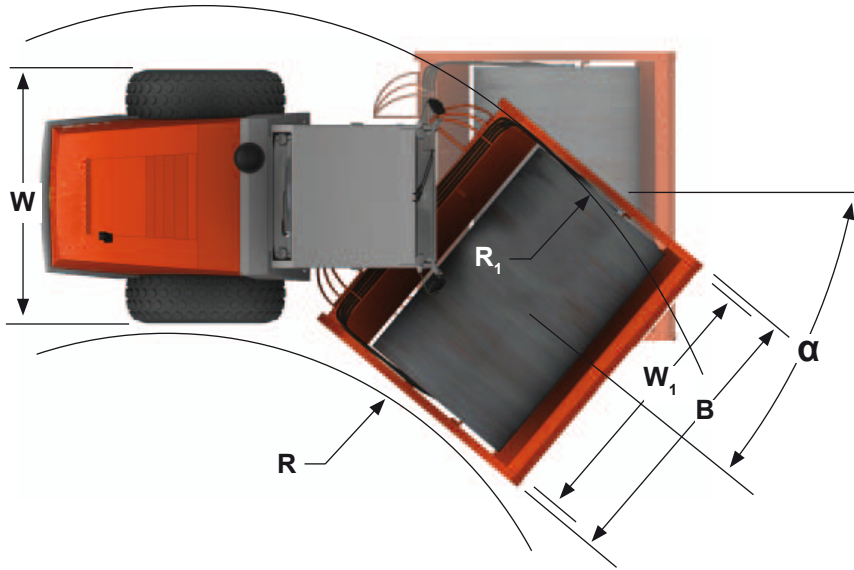

HR70C-9	smooth drum	pad foot drum
A	2720 mm	2720 mm
B	1850 mm	1850 mm
D	375 mm	375 mm
H	2723 mm	2728 mm
H ₁	1250 mm	1140 mm
L	5032 mm	5032 mm
R	3900 mm	3900 mm
R ₁	5600 mm	5600 mm
W	1700 mm	1700 mm
W ₁	1700 mm	1700 mm
α	+ / - 30°	+ / - 30°

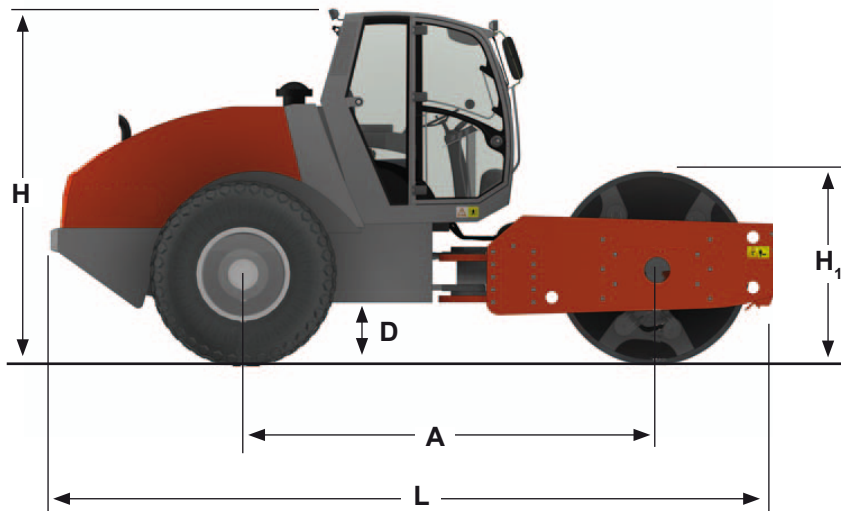

2.1.3 HR110C-9/HR120C-9/HR140C-9: Dimensions

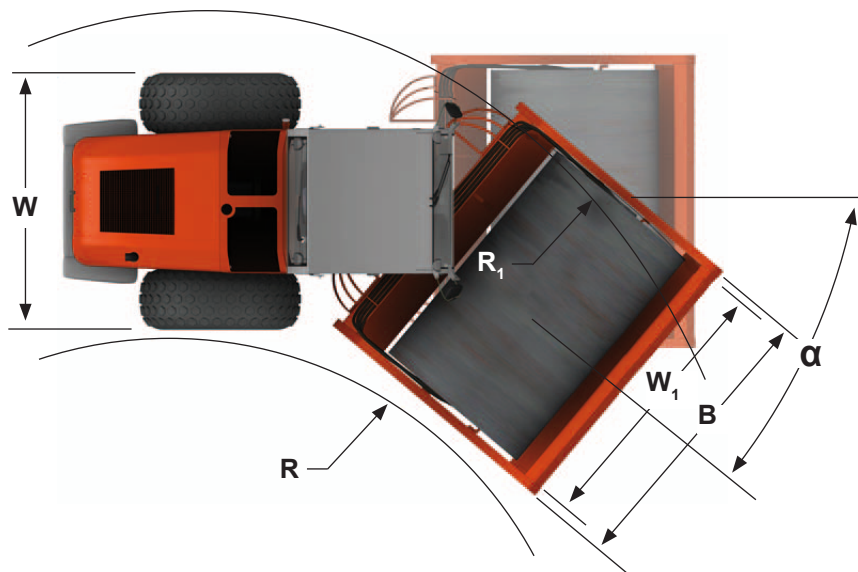

HR110C-9/120C-9/140C-9	smooth drum	pad foot drum
A	3195 mm	3195 mm
B	2270 mm	2270 mm
D	490 mm	490 mm
H	2920 mm	2920 mm
H ₁	1500 mm	1390 mm
L	5757 mm	5757 mm
R	4860 mm	4860 mm
R ₁	7015 mm	7015 mm
W	2090 mm	2090 mm
W ₁	2100 mm	2100 mm
α	+ / - 30°	+ / - 30°

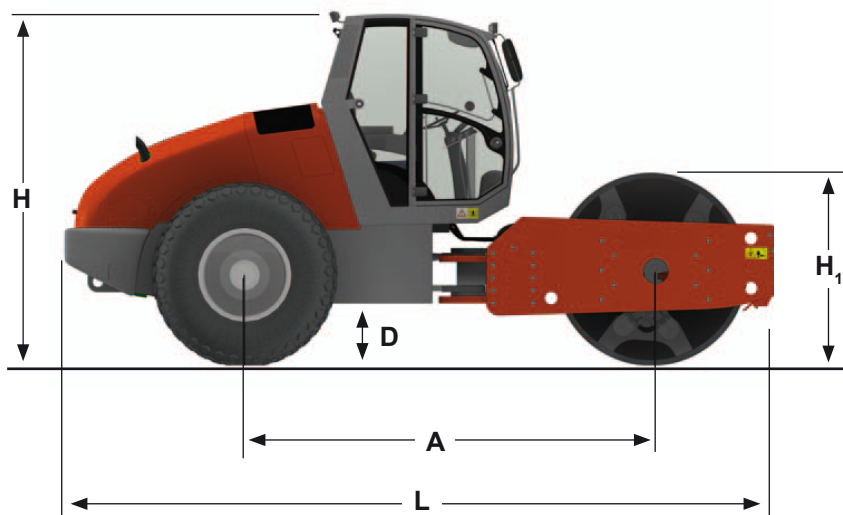

Tires

Standard...	HR70C-9	HR110C-9/HR120C-9/HR140C-9
...with smooth drum	16.9 - 24	23.1 - 26
...with pad foot drum	16.9 - 24 TR	23.1 - 26 TR

Fill levels

	HR70C-9	HR110C-9/HR120C-9/HR140C-9
Fuel tank (in liters)	167 l	300 l
Hydraulic oil tank (in liters)	68 l	106 l

Diesel engine

	HR70C-9	HR110C-9	HR120C-9	HR140C-9
Make	Perkins 1104C-44	Deutz TCD 2012 L4		
Nominal output (kW / HP)	61.5 / 84	96 / 130	96 / 13	103 / 140

Speed

	HR70C-9	HR110C-9/HR120C-9/HR140C-9
Speed (km/h)	0 - 10	0 - 12.5

2.1.4 Roll-over protection system

The cabin of the compaction roller corresponds to the stipulations of standard ISO 3471 (1994). It has been tested in accordance with the currently valid acceptance test specifications for roll-over protection systems (ROPS) and a ROPS authorization has been issued.



CAUTION!

Any modifications of the cabin are permitted only after a written form of approval has been issued by F. Weyhausen within the scope of the certification tests. Otherwise, the ROPS certificate loses its validity. No liability will be assumed for any modifications of the cabin (drilling/welding) carried out without prior explicit approval of the manufacturer!



Chapter 3

Operating elements & displays

Contents

This chapter provides you with information about:

- the layout of the control elements & displays
 - the functions of the control levers
 - switches and circuitries referring to roller operation
- 

3.1 Control elements and displays

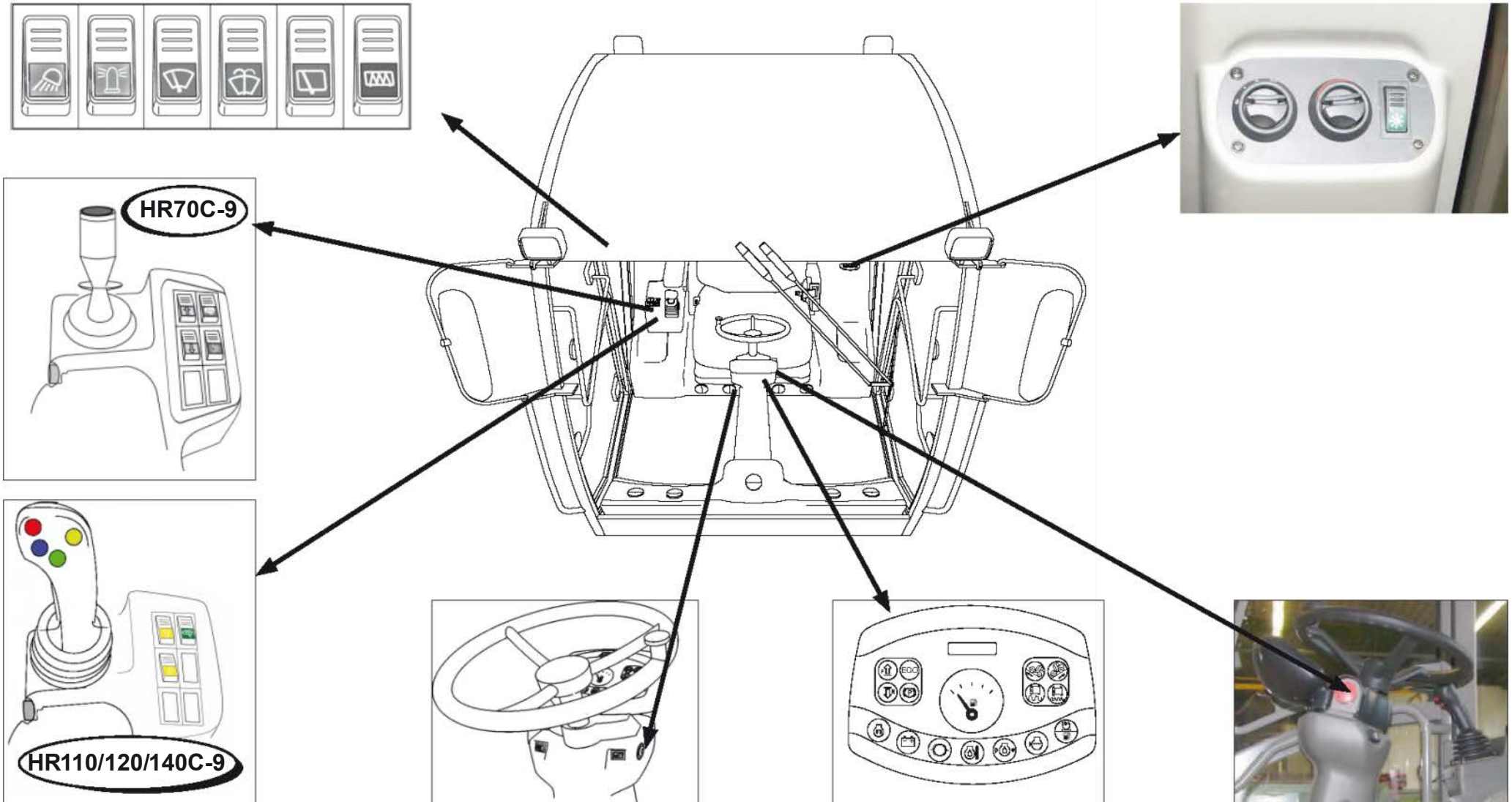

3.1.1 Displays on the dashboard

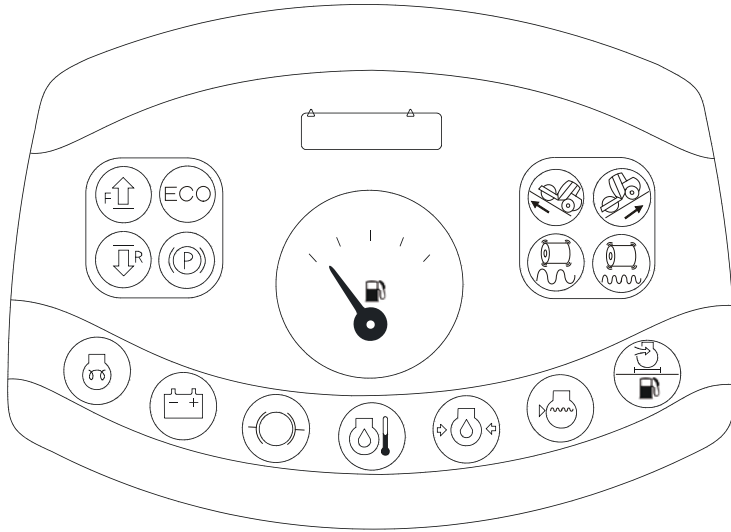

Symbol	Function	Description
	Forward motion	Light indicates forward motion
	Reverse motion	Light indicates reverse motion
	ECO Speed (Optional feature)	Activation of the ECO Speed mode
	Parking brake	Activation of the parking brake. Diesel engine can only be started with the parking brake applied (activated)
	Preheat	LED (yellow) indicates preheating process of the Diesel engine (ignition lock position I) and goes out as soon as the required starting temperature has been reached
	Charge control	Lights up on starting the Diesel engine but has to go out as soon as it has started
	Brake pressure	Light warns of an insufficient hydraulic oil pressure of the brake system
	Diesel engine oil temperature	If this symbol lights up, stop the compaction roller and let the Diesel engine idle until the engine oil has cooled down!
	Diesel engine oil pressure	If this symbol lights up during roller operation, immediately stop the Diesel engine and turn it off!
	Coolant level Diesel engine	Light warns of an insufficient coolant level in the cooling circuit
	Dual display Accumulation of dirt: fuel filter / air filter	If the corresponding display lights up, determine the cause and clean or replace the filter

3.1.2 Dashboard: Displays related to roller operation

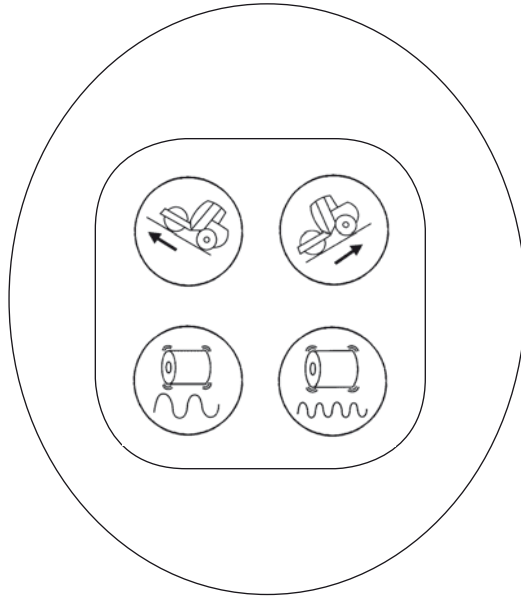

Symbol	Function	Description
	High Amplitude	Light indicates that a high amplitude has been set by means of the selector switch on the panel of switches next to the control lever
	Low Amplitude	Light indicates that a low amplitude has been set by means of the selector switch on the panel of switches next to the control lever
	Drum drive	Light indicates that overmodulation of the hydraulic engine at the drum has been activated by means of the switch on the panel of switches next to the control lever.
	Rear axle drive	Light indicates that overmodulation of the hydraulic engine at the rear axle has been activated by means of the switch on the panel of switches next to the control lever.

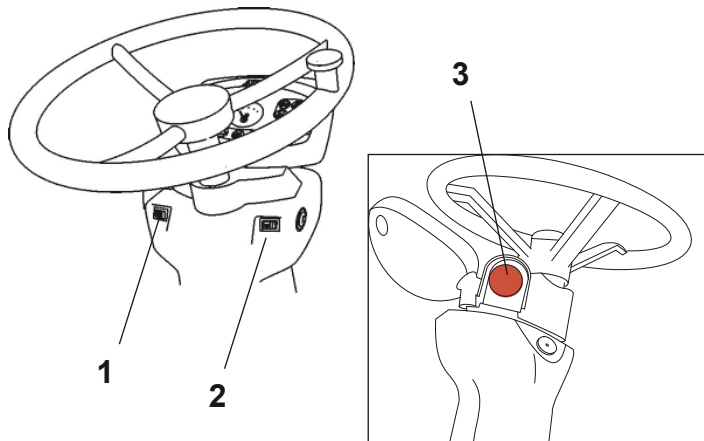

3.1.3 Steering column switches



Symbol	Function	Description
	Parking brake	Activates / deactivates the parking brake (1).
	Horn	Rocker switch for the horn (2).
	Ignition lock	Functions: Ignition off Ignition on Engine start
	Emergency stop push-button	In an emergency which calls for an immediate stop of the compaction roller, push the emergency stop push-button (3).

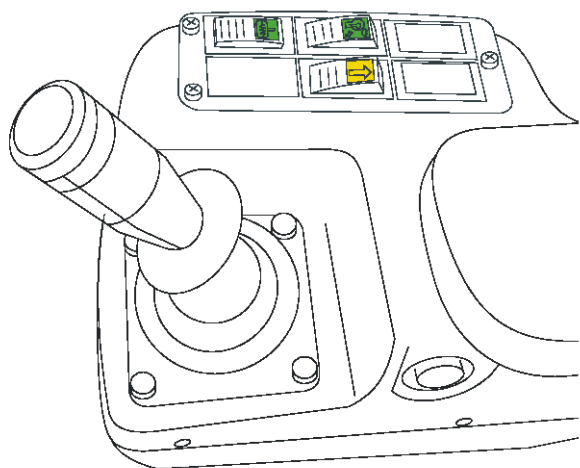

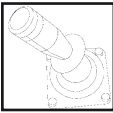
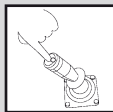
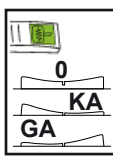
3.1.4 HR70C-9: Control lever (joystick) and panel of switches in the right armrest

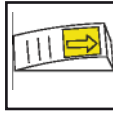

	Function	Description
	Control lever (Joystick)	The joystick in the right armrest serves to control the functions related to roller operation. <ul style="list-style-type: none"> Joystick moved forwards: Foward travel Joystick moved backwards: Reverse travel
	Button on the joystick	The button serves to activate / deactivate vibration (on / off)
	Selector switch vibration mode (soil compaction)	<ul style="list-style-type: none"> Central (middle) position (0) = Vibration off Rear pressed down (KA) = Surface compaction (low amplitude) Front pressed down (GA) = Deep compaction (high amplitude)
	Selector switch Diesel engine speed	Serves to activate or deactivate the 2nd roller operation stage (the availability of this option depends on the specific type) <ul style="list-style-type: none"> Front pressed down (Rabbit) = 1st stage: vibration mode Rear pressed down (Turtle) = 2nd stage: vibration & drive mode
	Overmodulation (HA control)	Overmodulation drum drive on / off

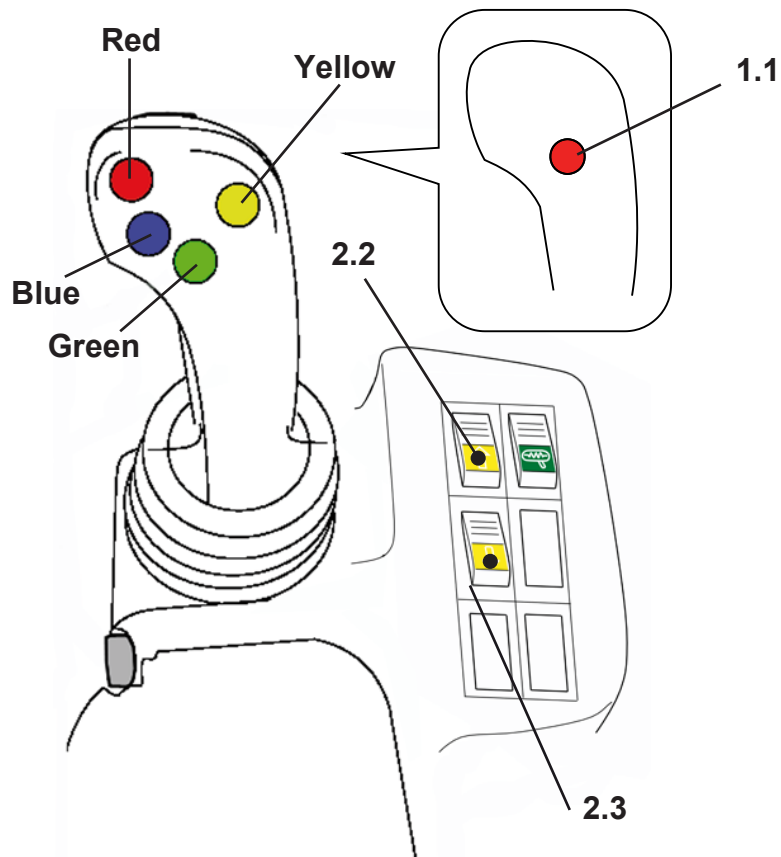
3.1.5 HR110C-9/HR120C-9/HR140C-9: Control lever (joystick) and panel of switches in the right armrest

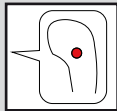

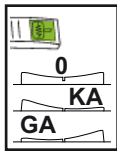
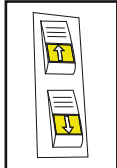
	Function	Description
	Control lever (joystick)	The joystick in the right armrest serves to control the functions regarding roller operation. <ul style="list-style-type: none"> • Move the joystick forwards for forward motion. • Move the joystick backwards for reverse motion.
 	Joystick buttons	The colors and the ergonomic design of the joystick buttons render it particularly easy to activate a number of functions: green = Neutral position (Diesel engine idle speed) blue = drive mode red = drive & work mode yellow = ECO Speed (if this optional feature is not available for your machine, actuation of this button just reduces the Diesel engine speed; working is not possible) For information on ECO Speed, see chapter Options . The red (vibration on/off) button (1.1) can be found on the front side of the joystick.
	Selector switch vibration mode	<ul style="list-style-type: none"> • Central (middle) position (0) = Vibration off • Rear pressed down (KA) = Surface compaction (low amplitude) • Front pressed down (GA) = Deep compaction (high amplitude)
	Overmodulation (HA Control)	Overmodulation hydraulic motor drum On / Off (2.2) Overmodulation hydraulic motor rear axle On / Off (2.3)

3.2 Compaction roller functions

3.2.1 HR70C-9: Functions of the hydraulic HA control

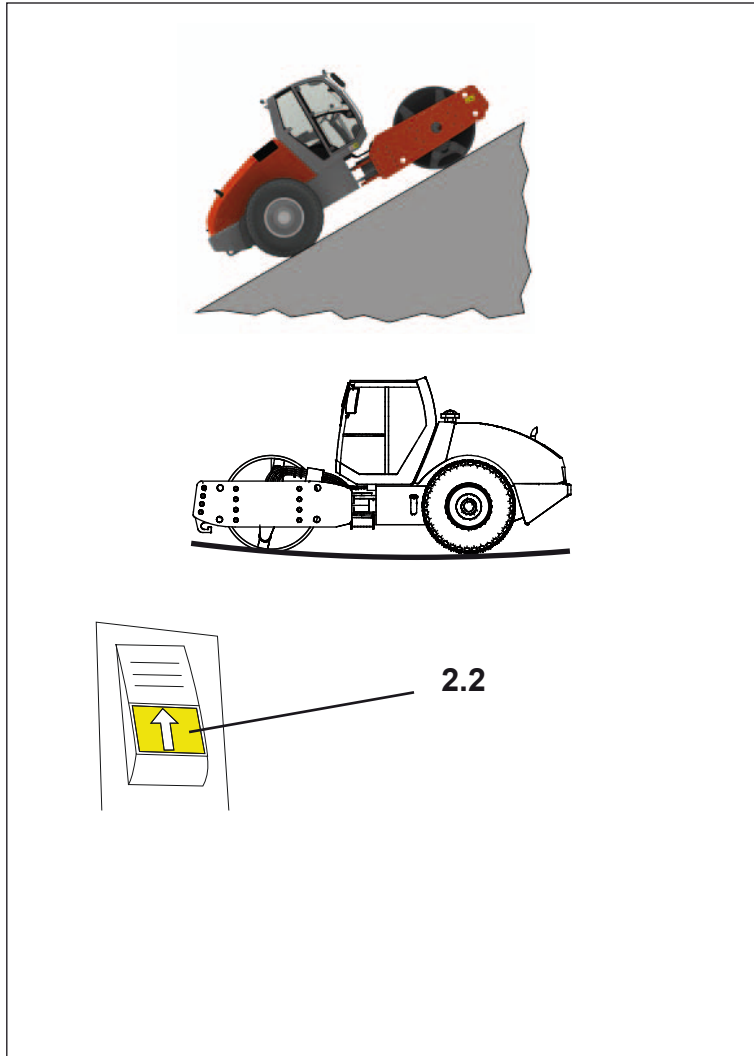

The hydraulic HA control serves to operate the compaction roller on level grounds or on slopes, either with or without vibration.

Notes on the hydraulic HA control



NOTE!

Overview: Benefits of the hydraulic HA control

- Automatic adjustment of the traction drive to different types of soil
- No intervention on the part of the driver required.
- Ideal adaptation to any type of ground, maximum traction on the axle.
- Continuous traction control at the axle.

Deactivating the HA control

By means of the HA control, traction drive gliding and spinning of the drums can be prevented...

- ... whenever driving the compaction roller across heavy terrain causes the drums or/and the wheels to sink into the ground or
- ... whenever slopes (inclinations) cause an increase in the tractive resistance

If slippery grounds or extreme inclinations make driving the compaction roller impossible, the HA control reduces the engine speed until the machine comes to a stop.

In certain situations, overmodulation of the HA control may be required, e.g.

- when starting the compaction roller with the drum/wheels sunk into the ground or
- while driving at a carefully set speed.

In order to do so, actuate the corresponding switch (2.2) to deactivate the HA control at the drum. The maximum driving torque is established at the roller drum.



WARNING!

If, even with the overmodulation activated, the required thrust cannot be established, do not continue operation on the slope in question and back up.

3.2.2 HR110C-9/HR120C-9/HR140C-9: Functions of the hydraulic HA control

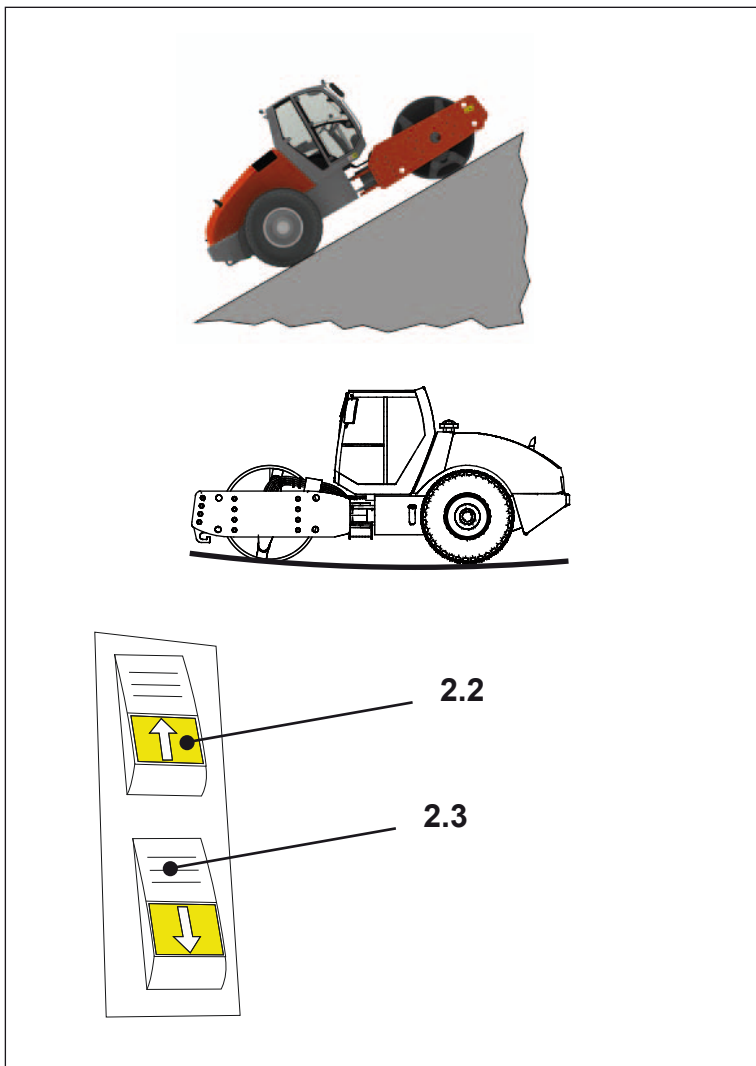

The hydraulic HA control serves to operate the compaction roller on level grounds or on slopes, either with or without vibration.

Notes on the hydraulic HA control



NOTE!

Overview: Benefits of the hydraulic HA control

- Automatic adjustment of the traction drive to different types of soil
- No intervention on the part of the driver required.
- Ideal adaptation to any type of ground, maximum traction on the axle.
- Continuous traction control at the axle.

Deactivating the HA control

By means of the HA control, traction drive gliding and spinning of the drums can be prevented...

- ... whenever driving the compaction roller across heavy terrain causes the drums or/and the wheels to sink into the ground or
- ... whenever slopes (inclinations) cause an increase in the tractive resistance

If slippery grounds or extreme inclinations make driving the compaction roller impossible, the HA control reduces the engine speed until the machine comes to a stop.

- In certain situations, overmodulation of the HA control may be required, e.g.
- when starting the compaction roller with the drum/wheels sunk into the ground or
- while driving at a carefully set speed.

In order to do so, actuate the corresponding switches (2.2 for overmodulation of the drum or 2.3 for overmodulation of the rear axle) to deactivate the HA control. The maximum driving torque is established at the roller drum.



WARNING!

If, even with the overmodulation activated, the required thrust cannot be established, do not continue operation on the slope in question and back up.

3.2.3 Maximum gradeability of the compaction rollers

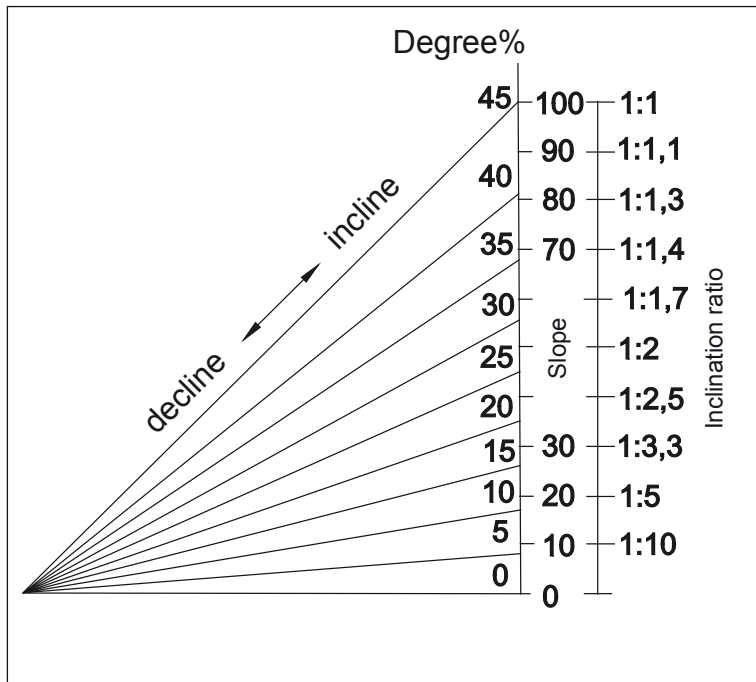

Type	with compaction, in %	without compaction, in %
HR70C-9	45	50
HR110C-9	43	48
HR120C-9	45	48
HR140C-9	40	45

See table on the left for information on the % / degree gradeability ratio.



Chapter 4

Options

Contents

This chapter provides you with information about:

- conversion from a smooth to a pad foot roller drum
 - converting and adjusting the scrapers
 - benefits and installation of a compaction measurement system
 - ECO Speed
- 

4.1 Converting from a smooth roller drum to a pad foot roller drum (Optional feature)

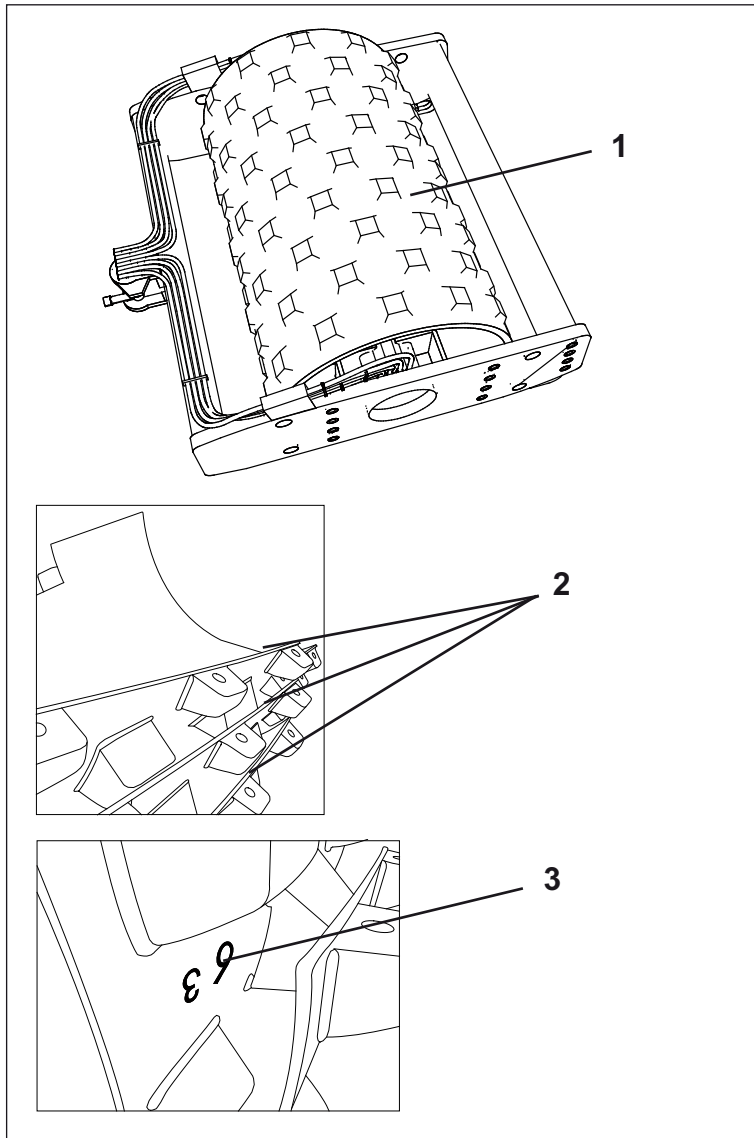

Safety instructions referring to work with the compaction roller



NOTE!

Obligation to inform yourself!

- Inform yourself of all issues related to the operation of the compaction roller.
- In order to carry out the conversion from smooth roller drum to pad foot roller drum, a crane disposing of a minimum lifting capacity of **8 tons** is required.

Converting from a smooth roller drum to a pad foot roller drum

In order to operate the compaction roller with a pad foot drum (1), you can order a retrofit kit containing three pad foot segments as an optional feature from the manufacturer.

Labeling of the pad foot segments

Each of the three pad foot segments (2) is individually labeled next to the split pad feet (3)



NOTE!

In order to mount the 3 pad foot segments on a smooth roller drum, observing the following instructions is of vital importance!

- Make sure you maintain the correct sequence!
- Pay close attention to the labeling (3) of the segments (2) and the correlation of the serial numbers.
- Only the corresponding segments (2) and identical serial numbers match up for this particular compaction roller.

4.1.1 Mounting the pad foot segments on a smooth roller drum

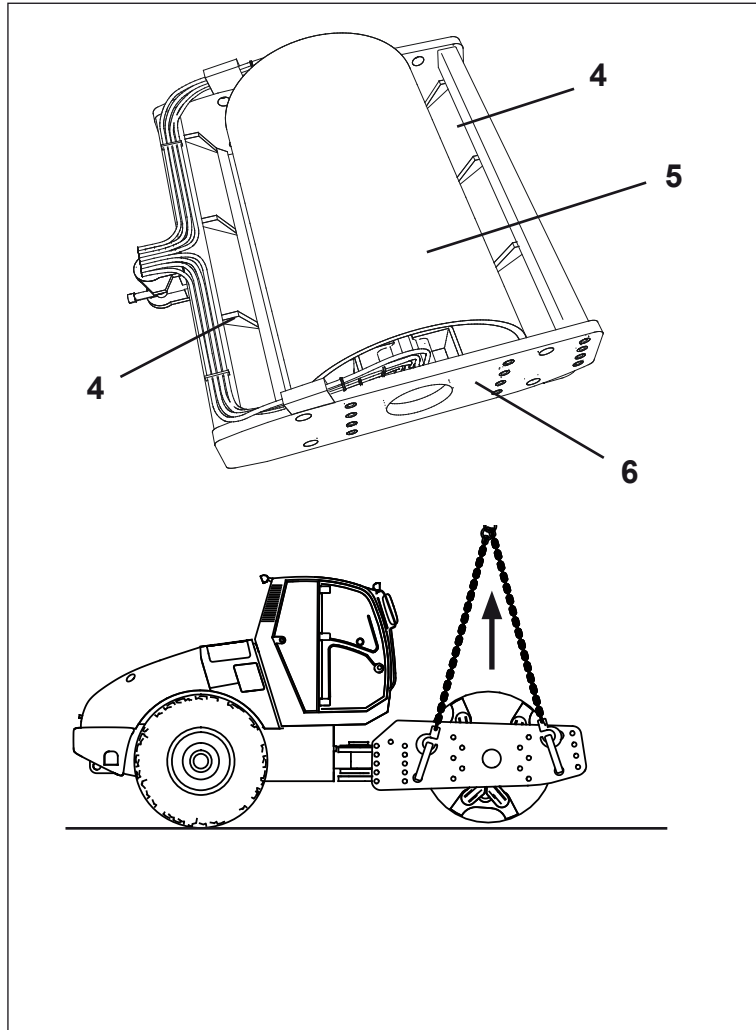

Dismantling the attached parts of the smooth roller drum

- Prior to starting work, put struts under the roller frame to support it.
- Remove the front and rear scrapers (4) from the smooth roller drum (5).
- Make sure the roller frame is securely fastened by appropriate tie-down equipment (6) before lifting it by means of a crane. The lifting height is sufficient if a pad foot segment can be placed under the smooth roller drum (5).
- Use a high pressure washer to clean the smooth roller drum (5).

4.1.2 Mounting the pad foot segments

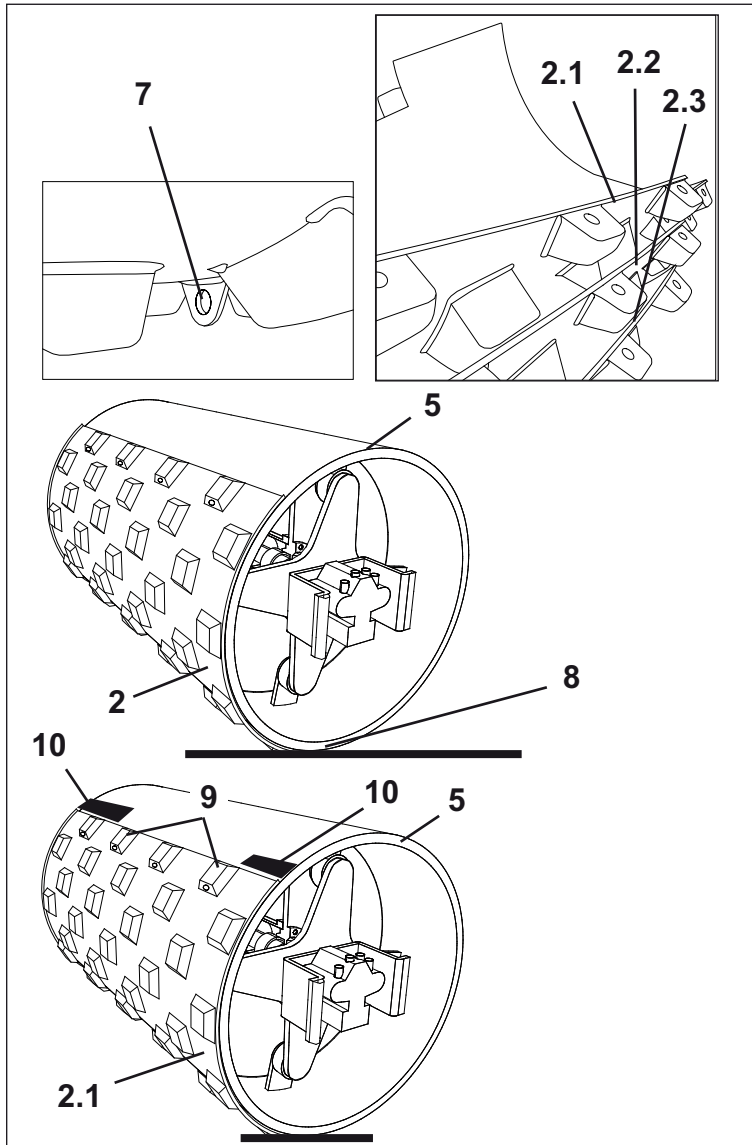

- Use a crane to lift the first segment (2.1) at the lifting lug (7) and to place it onto a transport vehicle at the lifting lugs. Drive the transport vehicle under the smooth roller drum (5), put down the segment (2.1) and adjust its position. Lower the roller frame by means of the crane and place the smooth roller drum (5) on the segment (2.1). Remove the tie-down equipment.
- Advance the compaction roller until the smooth roller drum (5) rests only on the rear edge (8) of the first segment (2).
- Lift the second segment (2.2) at the lifting lug (7). Place it on the top of the smooth roller drum (5), adjust it and connect it to the first segment (2.1) by bolting them together at the junctions (9).
- Use clamps (10) to attach the loose edge of the second segment to the smooth roller drum (5).
- Make sure there is enough space between the mounted segments and the roller frame.

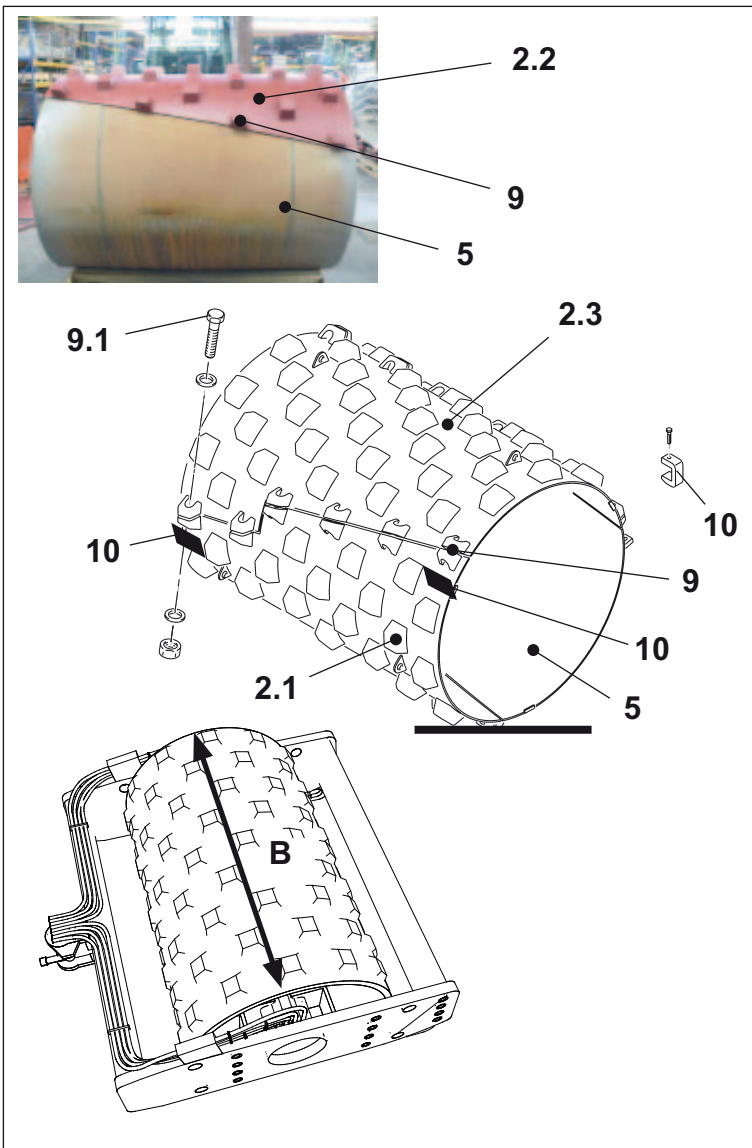

- Back up the compaction roller until the bare part of the surface of the smooth drum (5) points upward, rendering it possible to mount the third segment (2.3).
- Attach the third segment (2.3). Connect it to the first (2.1) and the second segment (2.2) by bolting them together at the junctions (9).
- Tighten all screws at the junctions evenly (9) along the entire width of the roller (B).
- Repeatedly drive the compaction roller forward and backward so the segment junctions point upward.
- Check all screw connections at the junctions (9) and tighten them.
- Tightening torques:
- **195 Nm** for **HR70C-9**
- **660 Nm** for **H110C-9/HR120C-9/HR140C-9**

4.1.3 Mounting the scrapers for the pad foot roller drum

- Install the corresponding pad foot scrapers (11) in order to use the drum as a pad foot roller (6).

Checking the segment connections



NOTE!

- After approx. **10 hours** of operation, check all screws at the segment connections again (9). If necessary, tighten them.
- Tightening torques:
 - **195 Nm** for **HR70C-9**
 - **660 Nm** for **H110C-9/HR120C-9/HR140C-9**.

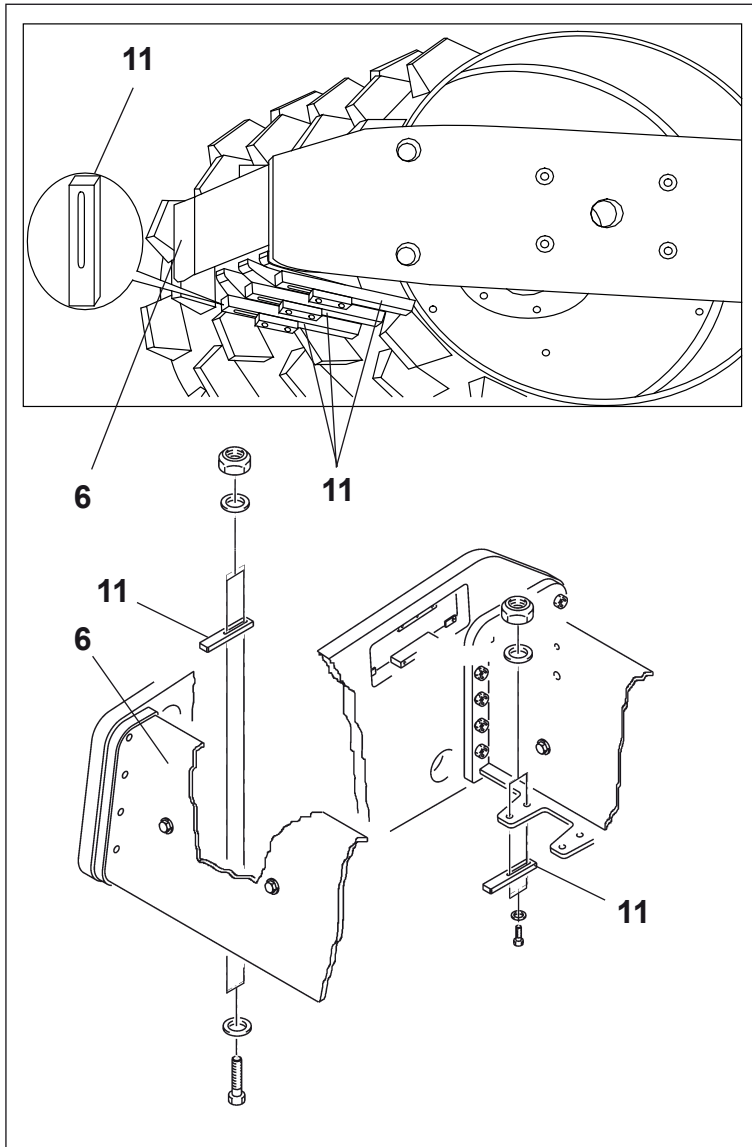

4.2 Compaction measurement system (optional feature)

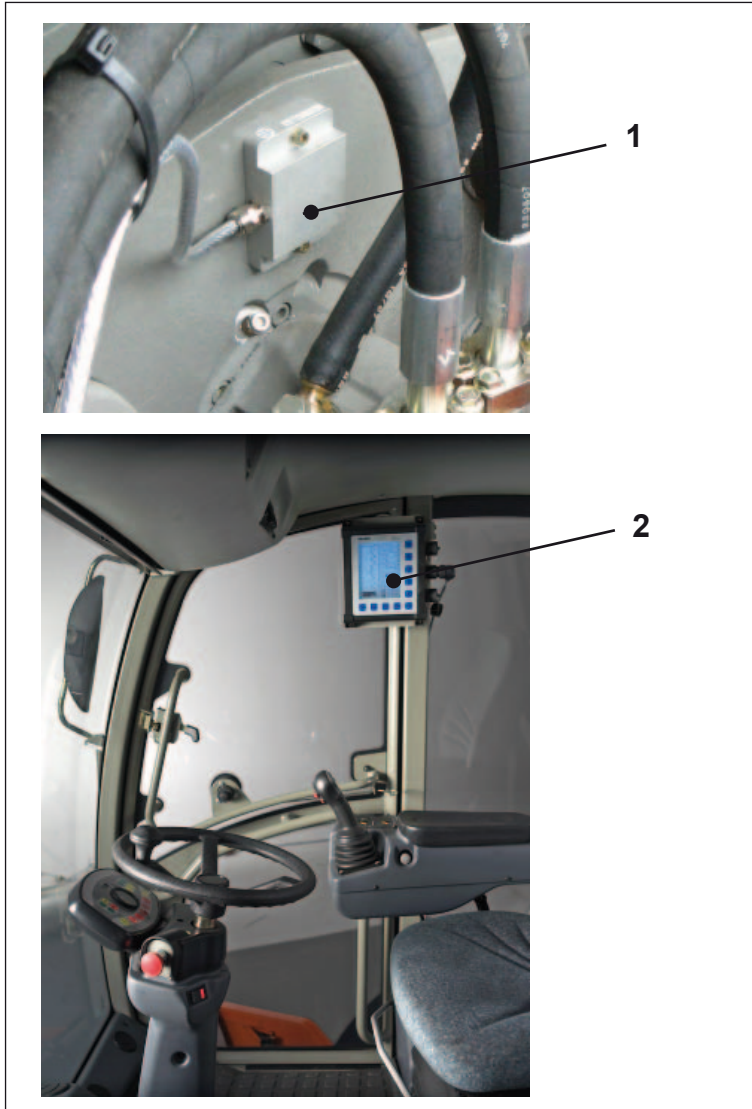

- If your compaction roller is equipped with a compaction measurement device (optional feature), the oscillation and acceleration of the drum are measured. The respective values are established by a sensor (1) and forwarded to a computer (2).
- The computer transfers the values to a display in the cabin. The representation on the display enables the driver to inform him-/herself of the current values concerning the degree of compaction and vibration at all times.



NOTE!

- The compaction measurement system establishes values and provides information on the degree of compaction.
- It does not interfere with the operational processes of the compaction roller.

- 1 Sensor at the drum
2 Compaction measurement system with documentation (data storage).

4.2.1 Variants of the compaction measurement system



Compaction measurement system with documentation (display, recording & data storage):

- In addition to displaying the current information regarding vibration and compaction, this type of measurement system (2) is able to gather, record and save all the respective information available, once operation of the vehicle has started.
- The memory capacity allows you to record approx. a week's (i.e. 40 hours') operation data at construction sites.
- The data is recorded per track, which ensures reliable recordings even for complex construction measures and intricate maneuvering.
- The data thus retrieved can be transferred to a personal computer and evaluated by means of the corresponding software.



NOTE!

From an economic point of view, the most relevant advantages of compaction measurement with storage function are: quality enhancement of the operation as a result of controlled compaction and the comprehensible documentation of the compaction results both for the building contractor and the client.

Analysis and evaluation of the data:

- The data of the entire construction project can be graphically displayed and printed as an overview.
- Areas of the image that contain values which are smaller than a set default value are marked in red.
- The overview can be gradually enlarged in order to represent certain parts in greater detail.
- Not only can each compaction roller track be marked separately, but it is possible to display and print the individual tracks as line diagrams.
- With the aid of a movable cursor, the compaction results achieved by different tracks and passes can be compared.
- The compaction values can easily be calibrated with the results of selective standard test runs.



Compaction measurement system with digital display:

An easy-to-install measurement system (3, with digital display only, no documentation) which serves to inform the driver of the degree of soil compaction.

The display with track and pressure function shows the relative degree of compaction of the soil while it is being compacted by the vibration roller drum.

The Display:

- Informs you of the current compaction result (**BIG** mode) as well as the compaction process, with the present position of the roller drum in the track and its relation to the default compaction value (**TRACK** mode).
- A zoom function serves to gradually enlarge the display of smaller values.

The relative degree of compaction:

- The more the soil is compacted, the higher the respective value.
- As soon as a sufficient degree of compaction has been reached, it appears as a stable/ fixed value (bar graph and numerical value).

Jump:

- Warning (bar graph and numerical value): Operation on soil which has been compacted too much can cause the vehicle to jump and result in material damage.

Amplitude:

- Vertical oscillation of the drum in **mm**.

Frequency:

- Current frequency of the vibration system in **Hz**.

Speed:

- Display in **km/h**

Track:

- Display of the compaction process per track, the current position (in **m**) and the default value (shown as a dashed line).

4.2.2 Installing the sensors and connecting them to the compaction measurement system

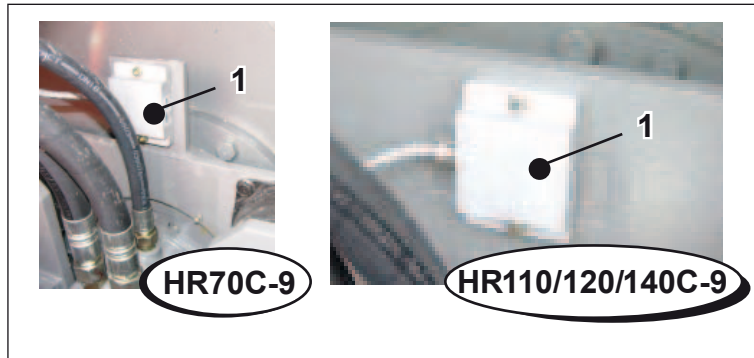

Installing the sensor at the roller drum:

HR70C-9:

- Weld the sensor bracket onto the center of the side plate (distance between the top holes: **10 mm**).
- Screw on the sensor (1); fix it by means of Loctite 243. The arrow on the sensor (1) must point upwards.

HR110C-9/HR120C-9/HR140C-9:

- Install vertically, above the center of the axle, threaded holes **M6** (distance to the upper edge: **18 mm**, distance between the drill holes: **84 mm**).
- Screw on the sensor (1); fix it by means of Loctite 243. The arrow on the sensor (1) must point upwards.

Laying the sensor wiring to the cabin:

Lay the sensor cables (4) along the hydraulic hoses and into the cabin from below. Attach the sensor cable to the compaction measurement system at the upper connection. The power supply cable of the middle connection at the compaction measurement system needs to lead into the side console of the cabin. Establish the plug connection (5) for the power supply.

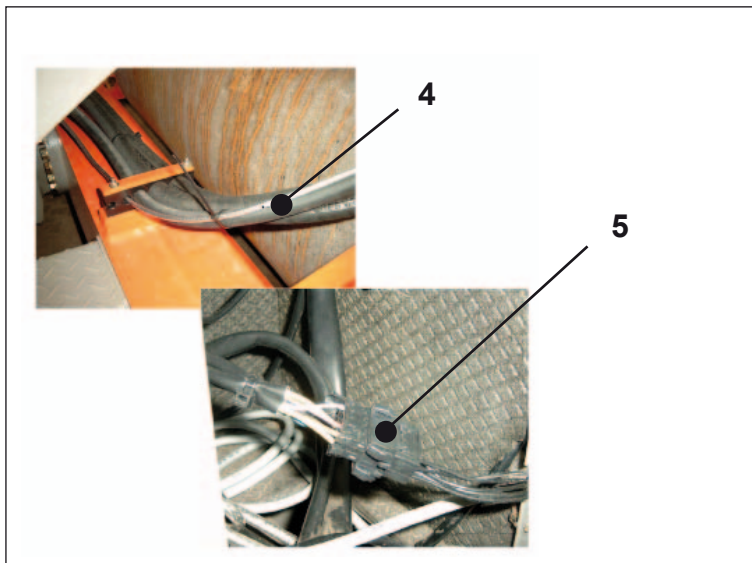

4.2.3 Installing the speed sensor at the axle

HR110/120/140C-9

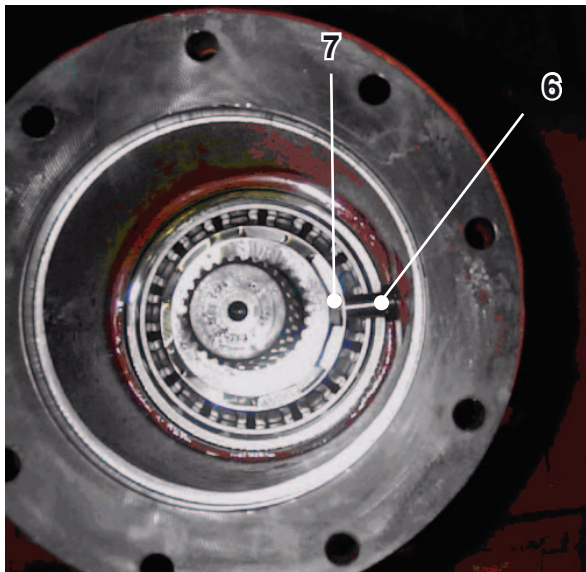
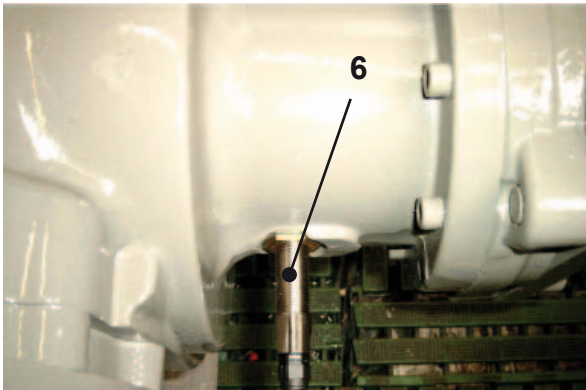

- **Compaction roller HR70C-9:**

Installation of a speed sensor is not possible for HR70C-9.

- **Compaction roller HR110C-9/HR120C-9/HR140C-9:**

For compaction roller types HR110-9, HR120-9 and HR140C-9, the speed sensor (6) is to be installed at the axle, at the speed connection.



WARNING!

- Prior to screwing in the speed sensor, check whether a tappet (7) of the engine speed disk in the axle is positioned right in front of the drill hole of the speed sensor (6).
- If you insert the speed sensor too far, it might collide with the tappet (7)!

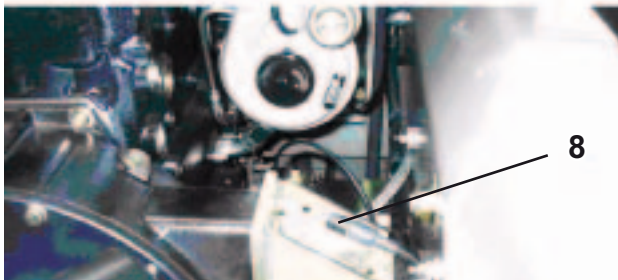
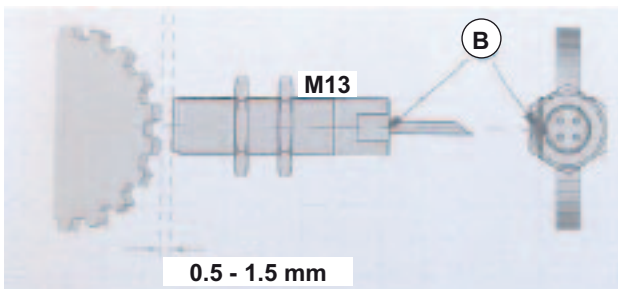
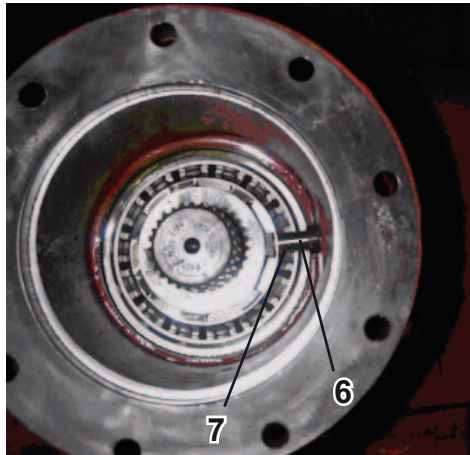

Adjusting the speed sensor:

- Screw the speed sensor (6, without the plug) into the threaded hole until its surface touches the tappet (7).
- Rotate the speed sensor (6) in the opposite direction by half a turn.
- Keep turning the speed sensor until the milled groove **B** is parallel to the running direction.
- Use a counter nut to lock the speed sensor (6) in this position.
- Lay the sensor cable and connect it to the plug (8) in the engine compartment.

4.2.4 Establishing the connections at the compaction measurement system

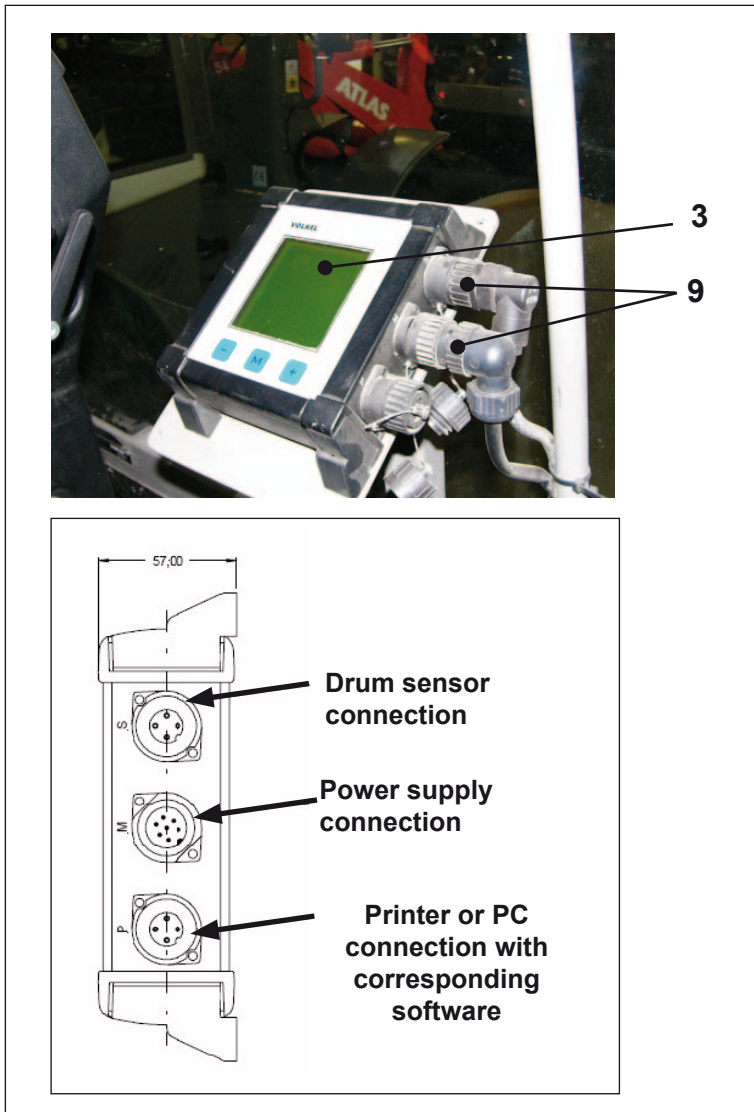

- The connections at the compaction measurement system (2,3) are established by means of plug adapters (9).
- Be sure to allocate them properly.

4.3 ECO Speed function (optional feature)

With the ECO Speed function, the compaction roller can be operated at a reduced Diesel engine speed while the compaction frequency remains at the previously set level.

4.3.1 Activating and deactivating the ECO Speed function

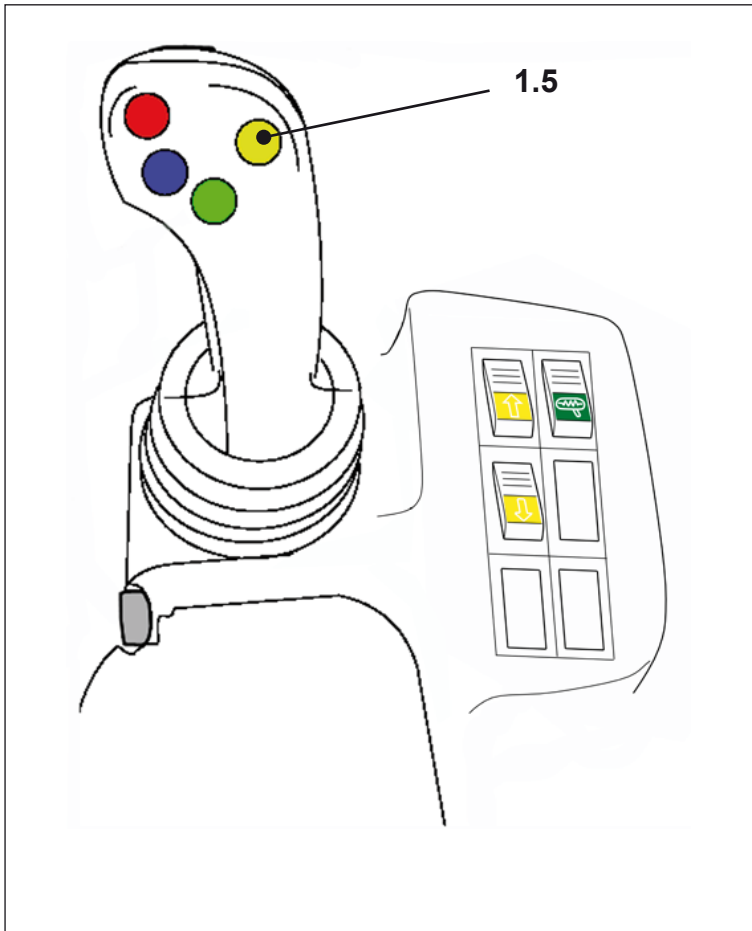

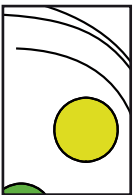
Switch	Function	Description
	ECO Speed (Optional feature, not available in all machines)	<ul style="list-style-type: none">• Button ECO Speed (1.5)• With the ECO Speed function, the compaction frequency remains constant while the Diesel engine speed is reduced.• Activate this function by pushing the ECO Speed (1.5) button.• The Diesel engine speed is reduced by 400 min⁻¹.• The frequency of the activated vibration remains at a constant level.• Actuate the button ECO Speed (1.5) again to deactivate the function.

4.3.2 Overview: Components of the ECO Speed system

The ECO Speed system is composed of the following elements:

- 1 Vibration pump with proportional solenoids
- 2 Control unit in the cabin
- 3 Printed circuit board
- 4 Additional cable set (order no. ZGBR-00746)
Printed circuit board / control unit ECO Speed (not shown)
- 5 Rexroth control box

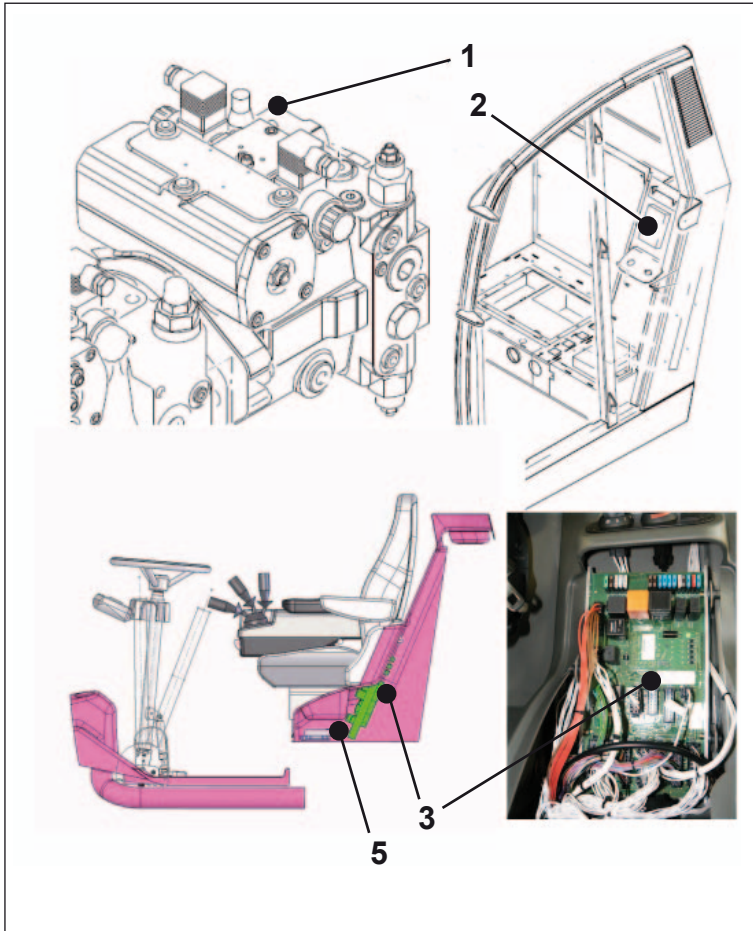



Chapter 5

Maintenance

Contents

This chapter provides you with information about:

- the required service and maintenance work
 - filling the tires
 - checking the tire inflation pressure
 - changing the tires
- 

5.1 Maintenance measures

5.1.1 Safety instructions referring to maintenance work



WARNING!

Obligation to inform yourself!

Be sure to take all safety precautions and to observe all instructions regarding the operation of the compaction roller when carrying out maintenance work!



WARNING!

Obligation to inform yourself!

Read the safety instructions and warnings in the operating and maintenance manual before starting any maintenance work and follow them!



WARNING!

Use signs and warning notices to point out that maintenance work is being carried out.



WARNING!

Prevent the compaction roller from unintentionally starting by removing the ignition key from the ignition lock.

5.1.2 Safety precautions to be taken prior to maintenance work

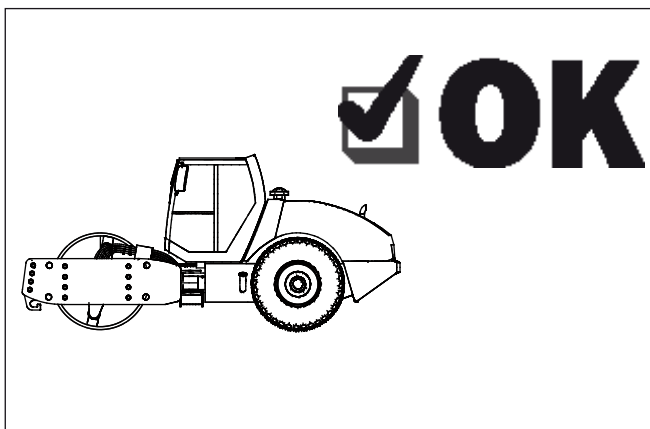
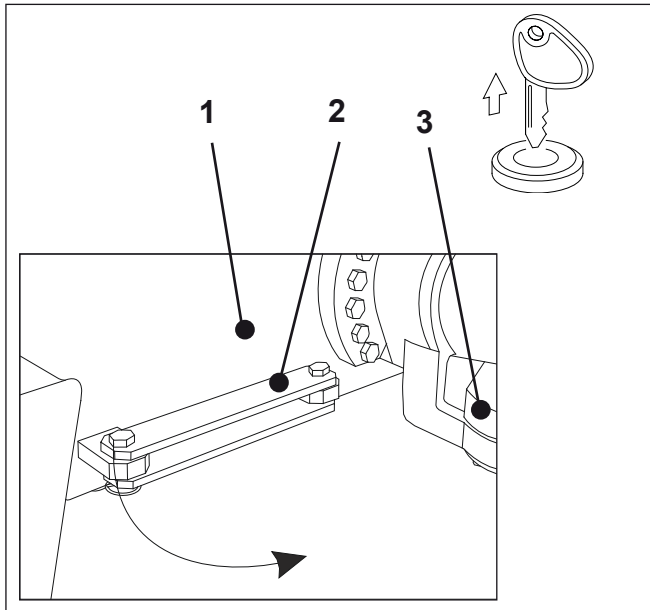

Securing the compaction roller before taking any maintenance measures:

Stop the Diesel engine and secure it against unintentional activation by pulling out the ignition key.

- Activate (apply) the parking brake.
- Secure the wheels at the rear axle by means of wheel chocks.
- In case the maintenance work needs to be carried out in the work zone, be sure to create a safe working environment.
- Ensure the compaction roller's stability.
- Protect the work area against moisture and dirt.
- Check whether the hydraulic system is depressurized.
- For work at the roller drum, the drum frame or the steering system, always insert the anti-buckling device (1) between the drum frame and the rear end and secure it (2).
- Use only tools that are mentioned and recommended in the operating and maintenance manual.

After completing the maintenance work:

- Ascertain that the compaction roller is in a safe operating condition.
- Check the hydraulic system of the compaction roller for leaks after starting it.
- Test the roller functions
- Do not resume operation of the compaction roller before thoroughly checking the vehicle.

5.1.3 HR70C-9: Maintenance overview

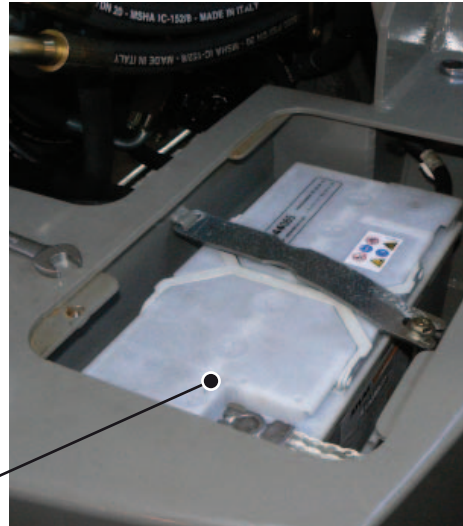

- 1 Engine compartment
- 2 Diesel engine
- 3 Hydraulic pump assembly
- 4 Battery
- 5 Hydraulic tank
- 6 Vibration drive
- 7 Drum drive

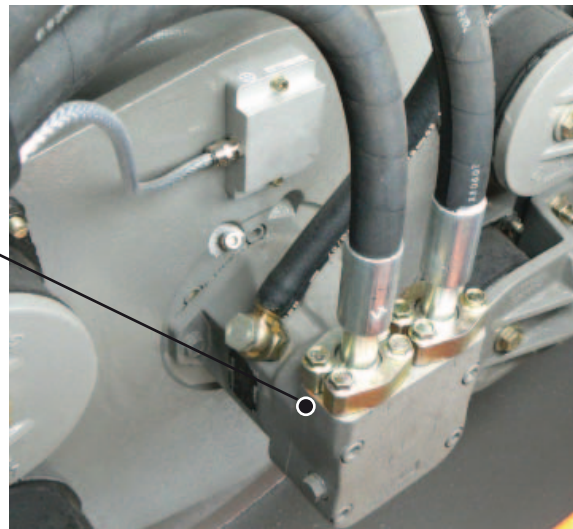

5.1.4 HR110C-9/HR120C-9/HR140C-9: Maintenance overview

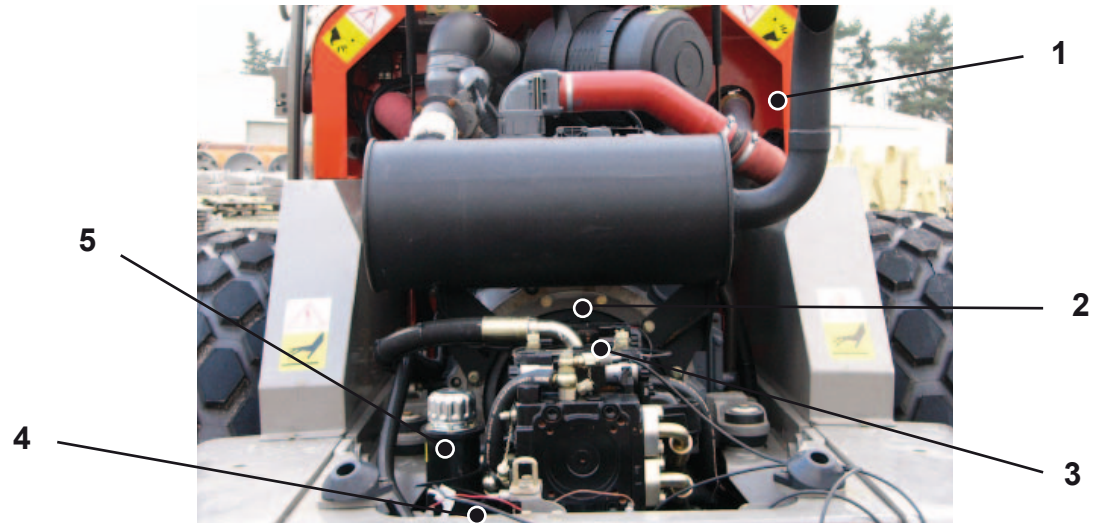

- 1 Engine compartment
- 2 Diesel engine
- 3 Hydraulic pump assembly
- 4 Battery
- 5 Hydraulic tank
- 6 Vibration drive
- 7 Drum drive

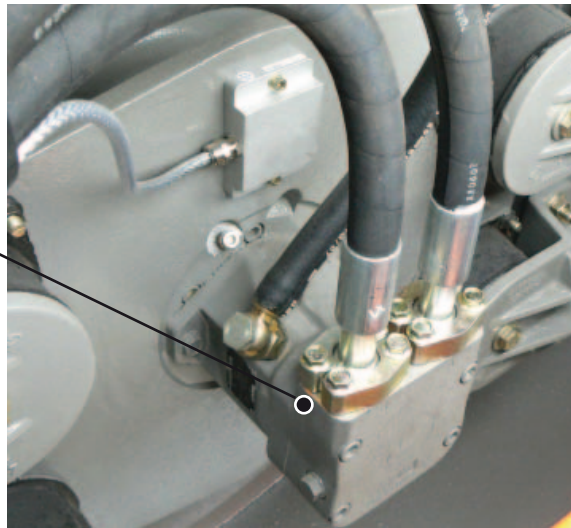

5.1.5 Maintenance instructions referring to the initial operation

Delivery receipt:



NOTE!

Make sure all checks and maintenance measures required for the initial operation are carried out in the presence of the customer and his/her staff. Obtain a written confirmation.

- Ascertain the completeness of the delivery (incl. all accessories & the documentation).
- Make a note of any damage found.
- Refer to the chapter **Note of delivery and verification of inspections** in the operating manual for information on the default maintenance intervals and maintenance certificates.

Testing the operating state of the vehicle:



NOTE!

Carry out the maintenance work described below in the presence of the operating staff (i.e. the driver) and the service staff of the customer. Refer to the corresponding sections of the operating and maintenance manual.

Checking the fill levels:

Check whether the following fill levels correspond to the required levels as stated in the maintenance manual:

- Engine oil level
- Hydraulic oil level
- Fill level in the drum drive
- Fill level in the vibration drive
- Checking the tire inflation pressure

Screw connections:

- Check all screw connections
- Use a torque wrench to tighten the wheel nuts (tightening torque: **500 Nm**).

Hydraulic system:

- Check the hydraulic hoses and screw connections for leaks.

5.1.6 Instruction and demonstration at the machine



NOTE!

Perform the instruction in the presence of the operating staff (i.e. the driver) and the service staff of the customer. Make sure that it is understood and that the individuals in question will read and comprehend the operating & maintenance manual .

Vehicle documents and operating manual:

- Hand out the documents related to the machine and point out their importance.
- Explain the structure and the contents of the operating and maintenance manual.
- Be sure to refer to the safety instructions and stress the importance of observing them.
- Explain the operation and the functions of the compaction roller, based on the instructions in the operating and maintenance manual.



NOTE!

Bear in mind that, after your initial instruction and demonstration, the operating & maintenance manual will be the only resource for obtaining information on the operation of the vehicle.

Operating elements and displays (cabin):

When giving the operation staff instructions related to the driver`s compartment, adhere to the sequence provided by the operating and maintenance manual:

- Begin by explaining the adjustment of the driver`s seat.
- Explain the functions of the switches, the buttons and the symbols of the dashboard and the steering column.
- Provide information on the joystick buttons and the corresponding symbols on the dashboard.
- Point out the connections between certain functions, e.g. the parking brake and engine start.
- Functions of the control lever for work with the compaction roller.
- Point to the specifications of the required hydraulic - , gear- and engine oil types.

Working with the machine:

Soil compaction options

Vibration modes

Roller drum types

Operation on slopes

Driving the machine:

Transporting the compaction roller.

Refer to the corresponding instructions in the operating and maintenance manual when explaining the towing process.

Maintenance work:

Filling the tires with water.

Checking the tire inflation pressure.

After the initial operation and demonstration, eliminate any leaks and check the functions of the brake system and the electrical equipment.

Provide information on maintenance measures and intervals. Point out that the use of supplies and substances other than the ones approved by the manufacturer inevitably leads to the immediate expiry of the warranty.

5.1.7 Check list 1st inspection after 50 operating hours

Diesel engine:



NOTE!

In addition to the measures stated here, refer to the operating manual of the Diesel engine manufacturer and observe the instructions.

Checking the fill levels:

Check the engine oil level.

Check the hydraulic oil level.

Check the fill levels of the wheel drives at the rear axle.

Check the fill level in the housing of the rear axle.

Replace the breathers of the rear axle.

Check the oil level at the vibration drive.

Check the tire inflation pressure and the water level in the tires.

Screw connections:

Check the screw connections of the engine mounting at the Diesel engine.

HR70C-9: Tighten the connecting bolts basic frame / rear axle (**600 Nm**)

HR110/120/140C-9: Tighten the screw connections at the rear axle (**550 Nm**)

Tighten the screw connections at the articulated pendulum joint.

Check all other screw connections (see operating and maintenance manual for information on further tightening torques)

Diesel engine:

Replace the air filter cartridge of the Diesel engine. Clean the air filter housing, if necessary.

Tighten the fastening screws of the air intake system.

Tighten the fastening screws of the exhaust system/muffler.

Follow the instructions in the operating manual of the Diesel engine manufacturer in order to carry out any maintenance work related to the Diesel engine!

Hydraulic system:

Replace the oil filter cartridge at the pump assembly.

Check all hydraulic hoses and screw connections for leaks.

Check the ventilation filter at the hydraulic tank.

5.1.8 Table of lubricants

Greasing point	Lubricant	Viscosity	Equivalent standard
Diesel engine	API classification	SAE 10 W	
Arctic climate	CG 4/CH 4	SAE 20 W - 20	
Temperate climate		SAE 30	
Tropical climate		SAE 40	
All climates		SAE 15 W - 40	New machine
Hydraulic oil	ATLAS Spezial 46	ISO VG 32 ISO VG 46 ISO VG 68	New machine Pay particular attention to the specifications referring to operation with temperatures below 0° C. Be sure to preheat the hydraulic oil sufficiently.

5.2 Maintenance work

5.2.1 Maintenance work related to the Diesel engine

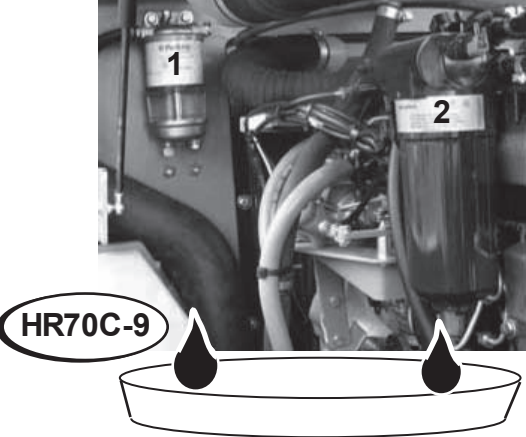
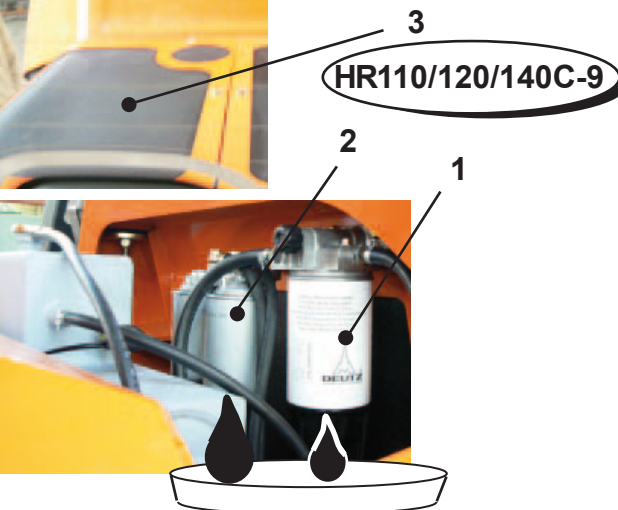
Illustration	Maintenance work: Fuel system
	<p style="text-align: center;">Weekly or at intervals of 100 operating hours:</p> <p>Check the fuel-water separator:</p> <ul style="list-style-type: none"> • The fuel-water separator (1) is attached to the stiffener wall of the cabin. • Open the engine hood. • Drain the fuel-water separator (1) via the drain screw below the separator.
	<p style="text-align: center;">50 operating hours after the initial operation and subsequently, at intervals of 500 operating hours or annually</p> <ul style="list-style-type: none"> • At intervals of 500 operating hours or once every 12 months, replace the filter cartridges of the preliminary fuel filters (2). • HR70C-9: Open the engine hood. HR110/120/140C-9: Open the cover (3) with the ventilation grills (on the right, in the direction of motion). • In order to collect the leaking oil, place an oilpan under the fuel filter. • Screw off both filter housings (cartridges) and dispose of them in an eco-friendly way, in accordance with waste disposal key 150299 (EU). • Slightly lubricate the sealing surfaces of the new filter cartridges. • Attach the filter cartridges. Screw them on by hand. • Let the Diesel engine turn via the starter. • Open the fuel ventilation plug and ventilate the fuel system. For a detailed description of the ventilation procedure, refer to the Perkins (for engine type 1104 C-44) or Deutz operating manuals (for engine type TCD 2012 L4).

Illustration

HR70C-9

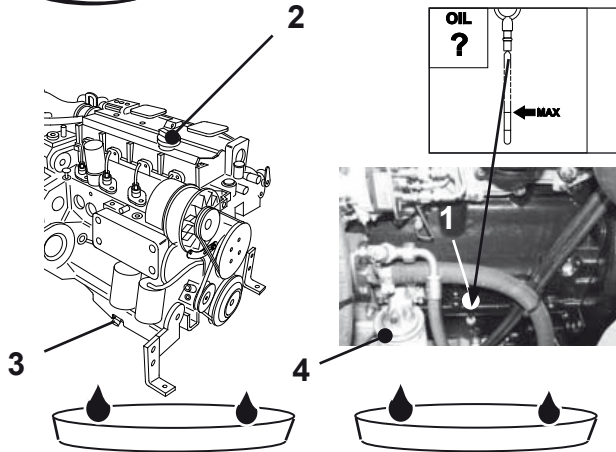

HR110/120/140C-9

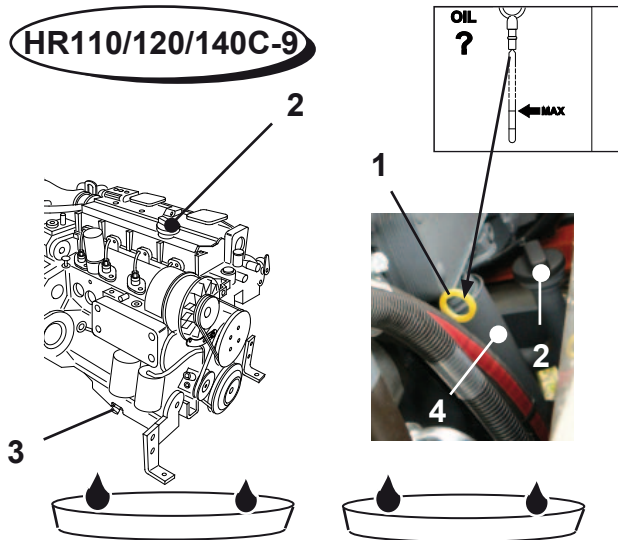

Maintenance work: Engine oil system

50 operating hours after the initial operation and subsequently, at intervals of 500 operating hours

Oil change:



WARNING!

Environmental protection!

The engine oil must not penetrate the ground, pollute water or leak into the sewer system. Be sure to collect it in sufficiently dimensioned receptacles and dispose of it in an eco-friendly way.

- Start the Diesel engine and let it run until it has reached operating temperature.
- Stop the Diesel engine and pull out the ignition key.
- Underneath the exterior oil drain plug, place a sufficiently dimensioned receptacle to collect the waste oil.
- Screw out the oil drain plug (3). Pull out the oil dipstick (1) and drain the oil. Dispose of the waste oil in accordance with EU waste disposal key **130202**.
- Fit the oil drain plug (3) with a new O-ring and screw it back in.

Replacing the oil filter:

- Unscrew and remove the filter housing (cartridge, 4). Dispose of it in accordance with EU waste disposal key **150299**.
- Slightly lubricate the sealing surface of the new filter cartridge.
- Attach the oil filter cartridge and screw it on by hand.

Adding oil:

- Fill a sufficient amount of engine oil (approx. 10 liters) into the Diesel engine via the filler neck (2).
- After adding oil, loosen the cap and let the Diesel engine run via the starter.
- Check the oil level at the oil dipstick. If necessary, add more oil.
- Start the Diesel engine and let it idle until it has warmed up.

Illustration

HR70C-9

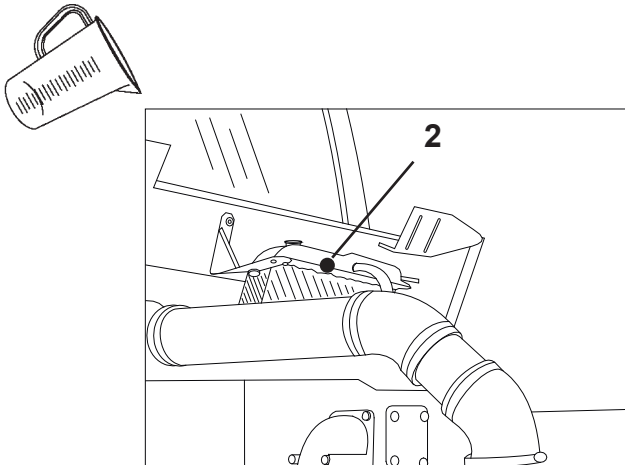

HR110/120/140C-9

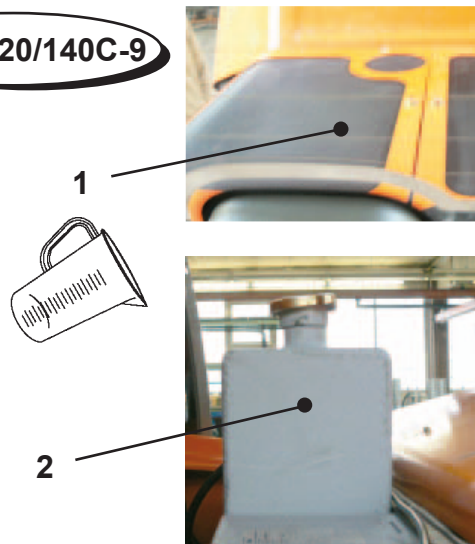

Maintenance work: Cooling system

To be carried out if the warning lamp lights up or after repair work:



WARNING!

Risk of burns caused by hot coolant!

Before you open the lid of the cooler, make sure that the Diesel engine and the cooling system have cooled down.

- **HR70C-9:** Open the engine hood.
- **HR110/120/140C-9:** Open the cover with the ventilation grills (1) (on the right, in the direction of motion).
- Carefully screw off the cover of the combination cooler (2).
- Check the coolant level.

If coolant needs to be added or after repair work, the following mixing ratio is required:

- Capacity of the cooling system: approx. **15 liters** (l).

Mixing ratio: 40% coolant for 1 liter of water, i.e. 0.6 l of water and 0.4 l of coolant.



Illustration **Maintenance work: Checking the V-belt**

50 operating hours after the initial operation and subsequently, at intervals of 500 operating hours

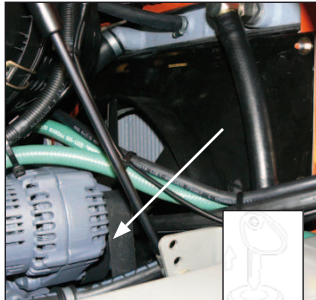
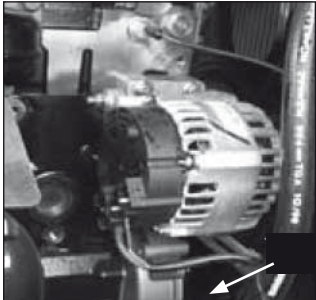

HR70C-9



HR110/120/140C-9

Check the V-belt tension and check the V-belt for signs of damage:



WARNING!

Never check the V-belt tension with the Diesel engine running!
Turn off the Diesel engine and pull out the ignition key.



NOTE!

Refer to the operating manual of the Diesel engine manufacturer for instructions regarding V-belt tensioning and replacement:

Perkins for engine type 1104 C-44
Deutz for engine type TCD 2012 L4

Illustration **Maintenance work: Replacing the combustion air filter**

50 operating hours after the initial operation and subsequently, at intervals of 500 operating hours

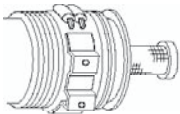

NOTE!

If the respective lamp on the dashboard indicates an accumulation of dirt at the air filter for the combustion air of the Diesel engine, clean or replace the air filter.
After a maximum of five cleanings by means of compressed air, replace the filter cartridge.
Wash the interior of the air filter housing and clean it; if necessary, vacuum it.



WARNING!

Damage to the Diesel engine!

Never attempt to clean the air filter by blowing air into it!

5.2.2 Hydraulic system

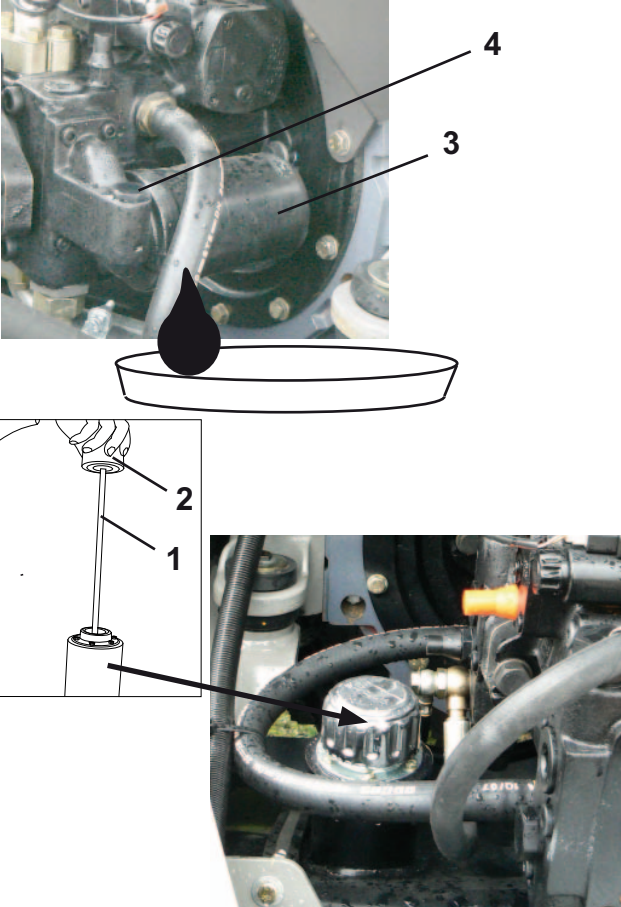
Illustration	Maintenance work: Changing the hydraulic oil and the oil filter
50 operating hours after the initial operation and subsequently, at intervals of 500 operating hours	
	<p data-bbox="786 427 2123 528">i <i>NOTE!</i> Prior to carrying out any maintenance work at the hydraulic system, be sure to consult the Table of lubricants for information on the specifications of the required hydraulic oils.</p> <p data-bbox="819 584 2123 611">Slightly loosen the oil filter cartridge (3) by means of a tension band or a similar tool, but do not screw it off yet.</p> <p data-bbox="786 667 2123 799">i <i>NOTE!</i> In order to prevent the contents of the suction pipe from leaking, stop loosening the filter cartridge as soon as a suction sound is audible. The air intake causes the oil in the suction pipe to flow back into the tank.</p> <ul data-bbox="775 847 2074 1050" style="list-style-type: none">• As soon as the suction sound stops, unscrew the oil filter cartridge and dispose of it in an eco-friendly way. EU waste disposal key: 150299 (EU).• Use clean oil to lubricate the sealing of the filter head (4).• Lubricate the new oil filter cartridge (3) with clean hydraulic oil.• Attach the new oil filter cartridge and screw it on by hand. <p data-bbox="786 1090 1581 1158">i <i>NOTE!</i> Do not use a tension band to screw on the filter cartridge!</p> <p data-bbox="775 1230 1178 1257">Checking the hydraulic oil level:</p> <ul data-bbox="775 1294 2033 1441" style="list-style-type: none">• Screw off the oil filler neck with the oil dipstick (1) and check the oil level.• If necessary, add hydraulic oil.• Clean the ventilation head (2).• In case you need to add hydraulic oil, refer to the Table of lubricants for the required oil specifications.

Illustration

Maintenance work: Hydraulic oil change

at intervals of 2000 operating hours (i.e. if you need to change the type of oil)

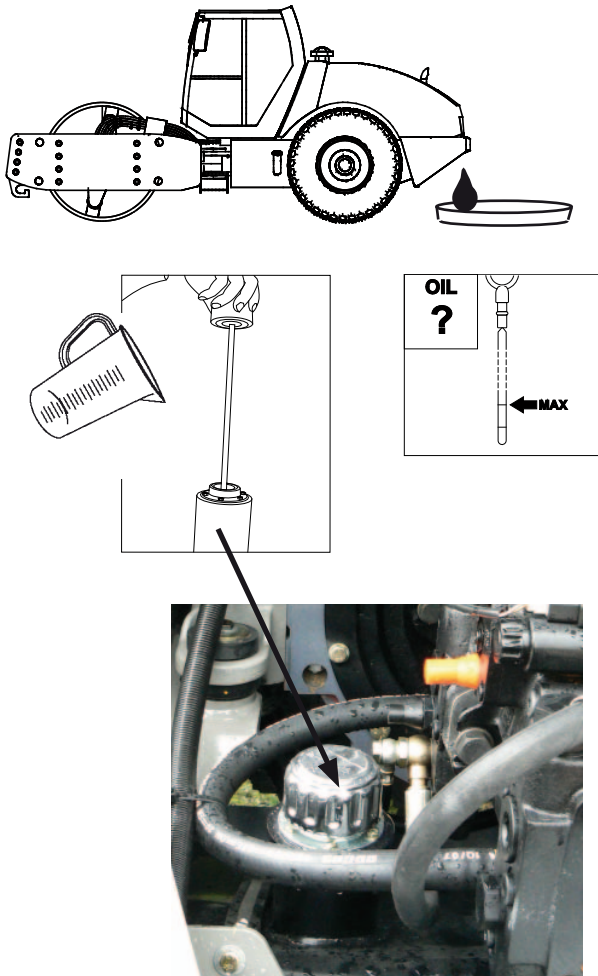

NOTE!

Take the compaction roller to a workshop in order to carry out the oil change.



WARNING!

Environmental protection!

The hydraulic oil must not penetrate the ground, pollute water or leak into the sewer system. Collect it in sufficiently dimensioned receptacles. Dispose of it in accordance with EU waste disposal key **130202**.

- Start the Diesel engine and let it run until the hydraulic oil has warmed up.
- Stop the Diesel engine and remove the ignition key.
- Place an oilpan under the hydraulic tank.
- Unscrew the oil filler neck with the oil dipstick.



NOTE!

Be sure to take the amount of hydraulic oil to be drained into account and to use a sufficiently dimensioned oilpan to collect the leaking oil.

- Screw off the oil drain plug. Remove the oil dipstick and drain the hydraulic oil.
- Dispose of the waste oil in accordance with EU waste disposal key **130202**.
- Replace the oil filter cartridge, see instructions above.
- Fit the oil drain plug with a new O-ring and screw it in.
- Add hydraulic oil via the filter.



CAUTION!

Be sure to exercise extreme cleanliness when filling in hydraulic oil!

Inform yourself of the type of hydraulic oil in the hydraulic system, see **Table of lubricants**.

- Add hydraulic oil via the oil filler neck.
- Start the Diesel engine and let it run until the hydraulic oil has warmed up.
- Stop the Diesel engine and pull out the ignition key.
- Check the hydraulic oil level again.

5.2.3 Rear axle

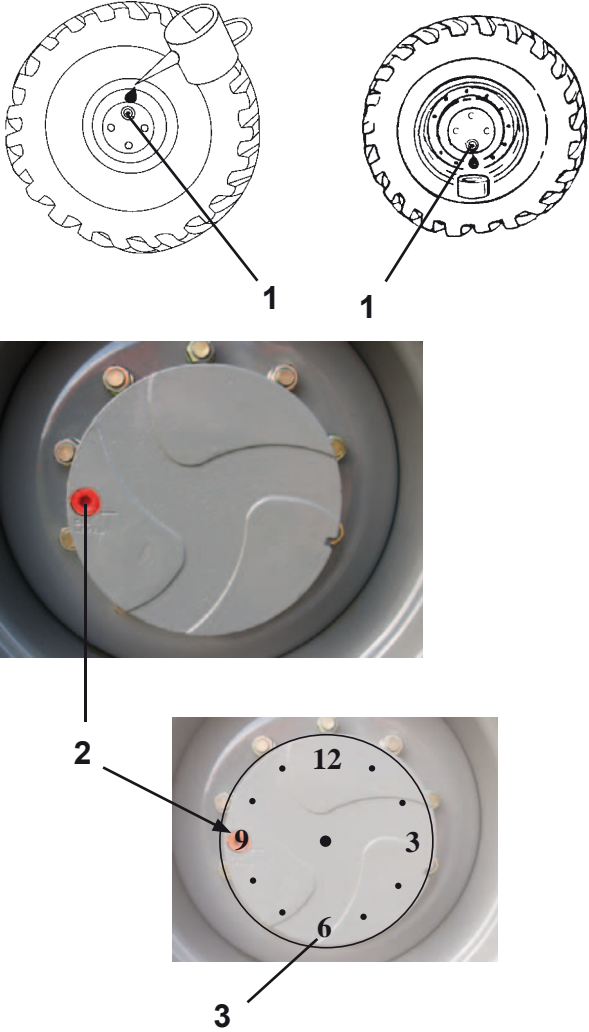
Illustration	Maintenance work: Check the oil level in the wheel drives
	<p data-bbox="887 357 2022 427">50 operating hours after the initial operation and subsequently, at intervals of 500 operating hours:</p> <div data-bbox="786 459 2107 564"> <p>NOTE! Prior to carrying out work at the rear axle, secure the compaction roller against rolling. Activate (apply) the parking brake and put wheel chocks under the tires.</p> </div> <div data-bbox="786 603 1917 708"> <p>WARNING! <i>Environmental protection!</i> The axle oil may not penetrate the ground, pollute water or leak into the sewer system.</p> </div> <p data-bbox="815 746 1341 772">Checking the oil level in the wheel drives:</p> <ul data-bbox="775 810 1951 999" style="list-style-type: none"> • Advance the compaction roller until the oil drain plug (1) is in the middle position, i.e. «3 or 9 o'clock» (see ill. on the left, 2). • Screw off the oil drain plug (1). • The oil level must be visible underneath the opening or tangible with a finger. • In case you need to add axle oil, be sure to refer to the specifications in the Table of lubricants. • Screw the oil drain plug (1) back in. <p data-bbox="875 1037 2029 1107">500 operating hours after the initial operation and subsequently, at intervals of 1500 operating hours:</p> <p data-bbox="819 1145 1279 1171">Changing the oil in the wheel drives:</p> <ul data-bbox="775 1209 2119 1366" style="list-style-type: none"> • If the oil in the wheel drives needs to be changed, advance the compaction roller until the oil drain plug (1) is in the lowest position («6 o'clock», see ill. on the left, 3). • Place a suitable receptacle under the wheel drive. • Screw off the oil drain plug (1) and drain the oil. • Screw the oil drain plug (1) back in and add axle oil, see instructions above.

Illustration

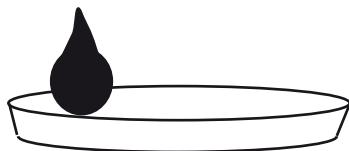
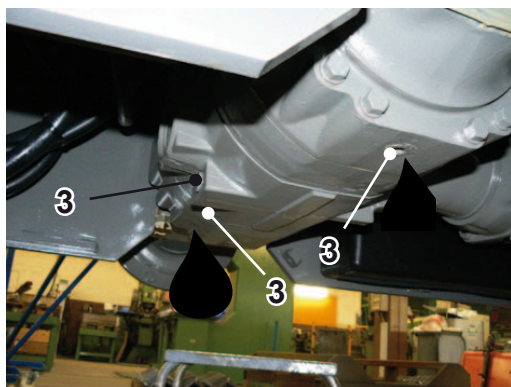

Maintenance work: Checking the oil level at the rear axle

50 operating hours after the initial operation and subsequently, at intervals of 500 operating hours:



NOTE!

Prior to carrying out work at the rear axle, secure the compaction roller against rolling. Activate (apply) the parking brake and put wheel chocks under the tires.



WARNING!

Environmental protection!

The axle oil may not penetrate the ground, pollute water or leak into the sewer system.

Checking the oil level in the axle housing:

- Unscrew the filler screw (2) from the axle housing.
- The oil level must be visible underneath the opening or tangible with a finger.
- Screw the filler screw (2) back in.

500 operating hours after the initial operation and subsequently, at intervals of 1500 operating hours:

Changing the oil in the axle housing :

- Place a sufficiently dimensioned oilpan under the three oil drain plugs (3).
- Screw out the oil drain plugs (3) and drain the axle oil.
- Dispose of the waste oil in accordance with waste disposal key **130202 (EU)**.
- Screw the oil drain plugs (3) back in.
- Be sure to refer to the **Table of lubricants** with regard to the required axle oil specifications.
- Fill new axle oil into the axle housing via the filler screws (2).
- Tighten the filler screws (2).

Illustration

Maintenance work: Checking and replacing the breather

50 operating hours after the initial operation and subsequently, at intervals of 500 operating hours:

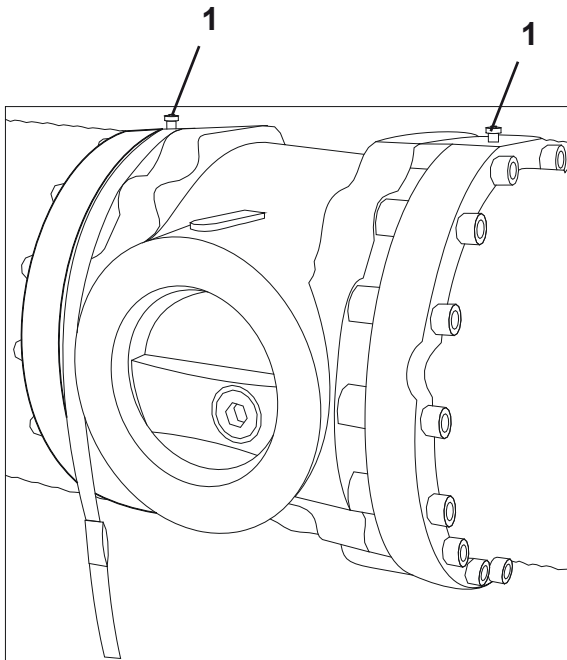

- Carry out a visual inspection to check the rear axle for oil leaks.
- Replace the breather (1) on the axle.
- The breathers are part of the maintenance kits (see spare parts list).

5.2.4 HR70C-9: Maintenance work at the drum drive

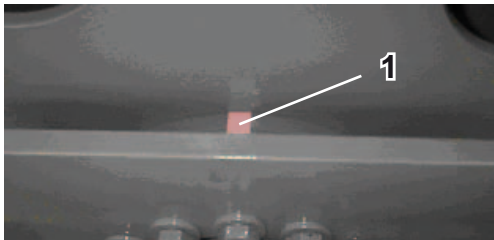
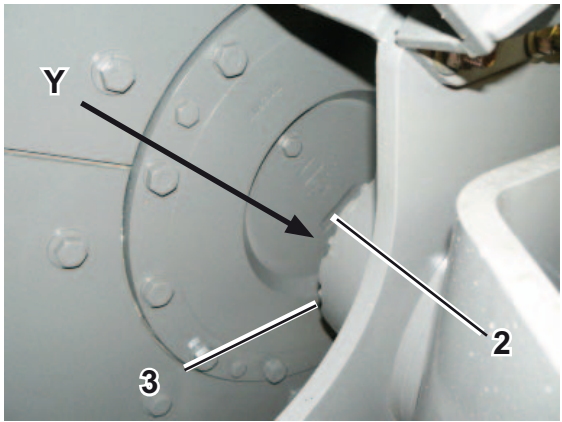
Illustration	Maintenance work: Checking the oil level in the drum drives, changing & adding oil
<p data-bbox="168 414 336 478">HR70C-9</p>  	<p data-bbox="884 359 2027 430">50 operating hours after the initial operation and subsequently, at intervals of 500 operating hours:</p> <div data-bbox="772 454 2128 582"> <p>NOTE! Prior to carrying out work at the drum drive, secure the compaction roller against rolling. Activate (apply) the parking brake and put wheel chocks under the tires.</p> </div> <div data-bbox="772 598 2128 726"> <p>WARNING! <i>Environmental protection!</i> The axle oil may not penetrate the ground, pollute water or leak into the sewer system.</p> </div> <div data-bbox="772 742 2128 869"> <p>NOTE! Prior to carrying out maintenance work related to the components of the roller drum, refer to the Table of lubricants for information on the required gear oil specifications.</p> </div> <ul data-bbox="772 869 2128 1077" style="list-style-type: none"> • The filler screw (1), the control screw (2) and the oil drain plug (3) are located on the left side, next to the traction motor. • Screw out the control screw (2) to check the oil level. Gear oil needs to leak from the drill hole. • If necessary, add gear oil at the plug (1) until oil starts leaking from the control screw (2). • Screw the plug back in. • Whenever you need to add oil, refer to the Table of lubricants for the required gear oil specifications. <p data-bbox="884 1093 2027 1165">500 operating hours after the initial operation and subsequently, at intervals of 1500 operating hours:</p> <ul data-bbox="772 1189 2128 1428" style="list-style-type: none"> • Changing oil in the transmission/gear box: • Unscrew the oil drain plug (3). • Dispose of the waste oil in an appropriate eco-friendly way. • Screw the oil drain plug (3) back in. • Remove the filler screw (1) and the control screw (2) and fill in gear oil from the top, until oil starts leaking from the control screw (2). • Attach and tighten the filler screw (1) and the control screw (2) again.

5.2.5 HR110C-9/HR120C-9/HR140C-9: Maintenance work at the drum drive

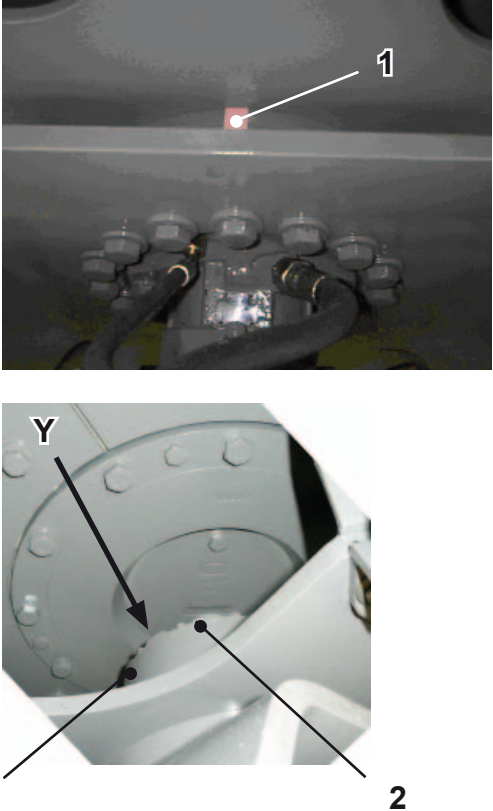
Illustration	Maintenance work: Checking the oil level in the drum drives, changing & adding oil
<p data-bbox="159 427 461 464">HR110/120/140C-9</p>  <p>The top photograph shows a close-up of the gear flange with a red laser line (1) pointing to a specific mark. The bottom photograph shows the gear box with a label 'Y' pointing to the inner gear side, and two screws labeled '2' and '3'.</p>	<p data-bbox="882 379 2018 453">50 operating hours after the initial operation and subsequently, at intervals of 500 operating hours:</p> <p data-bbox="781 488 875 584">i NOTE! Prior to carrying out work at the drum drive, secure the compaction roller against rolling. Activate (apply) the parking brake and put wheel chocks under the tires.</p> <p data-bbox="775 624 875 711">! WARNING! Environmental protection! The axle oil may not penetrate the ground, pollute water or leak into the sewer system.</p> <p data-bbox="781 772 875 868">i NOTE! Prior to carrying out maintenance work related to the components of the roller drum, refer to the Table of lubricants for information on the required gear oil specifications.</p> <ul data-bbox="770 903 2123 1123" style="list-style-type: none"> • Advance the compaction roller until the labeling (1) at the gear flange is visible and points upward. • The filler and the oil drain screw (2, 3) are both situated on the inner gear side Y. • If the labeling (1) is in the correct position, the control screw (2) is on the left side and the drain screw (3) points downward. • Remove the filler screw (2) from the gear box. The oil level should be tangible with a finger underneath the opening. If required, add the necessary amount of gear oil. Be sure to consult the Table of lubricants for information on the specifications of the required gear oil. <p data-bbox="882 1150 2033 1224">500 operating hours after the initial operation and subsequently, at intervals of 1500 operating hours:</p> <ul data-bbox="770 1259 2007 1410" style="list-style-type: none"> • Oil change at the gear box: • Advance the compaction roller until the control screw (2) is in its lowest position. • Screw out the control screw and drain the oil. • Advance the compaction roller until the control screw is in the middle position («3/ 9 o`clock»). Fill in gear oil and screw in the control screw (2).

5.2.6 Maintenance work at the vibration drive

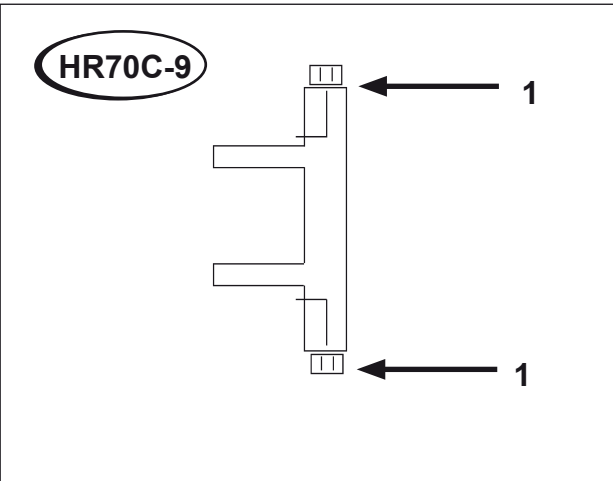
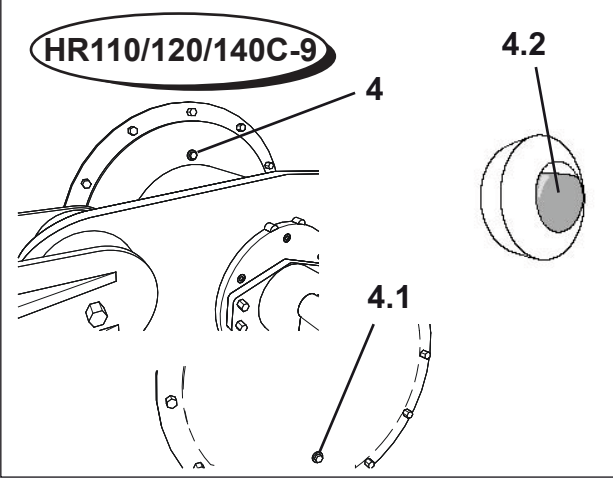
Illustration	Maintenance work: Checking the oil level at the vibration drive, changing & adding oil
50 operating hours after the initial operation and subsequently, at intervals of 500 operating hours:	
 <p>HR70C-9</p> <p>1</p> <p>1</p>	<p>NOTE! Prior to carrying out work at the vibration drive, secure the compaction roller against rolling. Activate (apply) the parking brake and put wheel chocks under the tires.</p> <p>WARNING! <i>Environmental protection!</i> The axle oil must not penetrate the ground, pollute water or leak into the sewer system.</p> <p>HR70C-9:</p> <ul style="list-style-type: none"> • Advance the compaction roller until the control screws (1) are in the lowest and top position. • Remove the lower control screw. Oil needs to leak from the threaded hole. If no oil escapes from the opening, add oil via the upper control screw until it starts leaking from the bottom screw. • Be sure to consult the Table of lubricants for information on the specifications of the required oil. • Screw the control screws (1) back in.
 <p>HR110/120/140C-9</p> <p>4</p> <p>4.2</p> <p>4.1</p>	<p>HR110C-9/HR120C-9/HR140C-9:</p> <ul style="list-style-type: none"> • Advance the compaction roller until the inspection glass (4) is in the lowest position («6 o'clock») (4.1). • This implies that the filler screw (4) is in the top position («12 o'clock»). • If, in this position, the gear oil level does not correspond to the illustration (4.2), oil needs to be added. • Be sure to consult the Table of lubricants for information on the specifications of the required oil. • Remove the filler screw (4) from the housing. • Add oil until the correct oil level is reached, see illustration. • Screw the filler screw (4) back in.

5.2.7 Maintenance work at the ventilation system

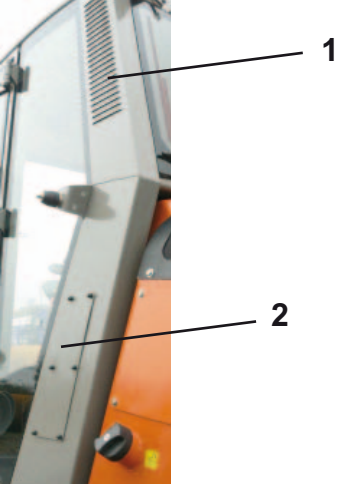
Illustration	Maintenance work: Replacing the filter units of the ventilation system
500 operating hours after the initial operation and subsequently, at intervals of 500 operating hours or in case of a high accumulation of dirt:	
 The illustration shows a close-up of a machine's ventilation system. A white ventilation slot is labeled with the number '1'. Below it, a grey cover is labeled with the number '2'. The machine's body is orange and white.	<p>Never use water jets or a high-pressure washer to clean the ventilation slots (1). Instead, always clean the ventilation slots by means of a heavy-duty vacuum cleaner. Open the cover (2) of the filter unit and replace the filter unit.</p>

5.2.8 Note regarding maintenance work related to the electrical installation

For information on maintenance work related to the electrical installation, see chapter **Electrical system**.

5.2.9 HR70C-9: Perkins Diesel engine maintenance schedule

at intervals of ... operating hours (max. permissible period of time)						Required measures
8 or daily	250 or every 6 months	500 or every 12 months	1000	2000	3000	
X						Check the coolant level.
	X					Check the coolant concentration. At intervals of 2 years, replace the anti-freeze agent. In case corrosive agent is used instead of anti-freeze agent, replace it at intervals of 6 months. Be sure you use the correct quantity.
	X					Check the condition and the tension of the drive belt.
			X			Replace the drive belt of the generator.
X						Drain the water from the preliminary filter (in case your vehicle is equipped with this feature).
		X				Replace the fuel filter element.
					X	Check the functioning of the injection nozzles. To be carried out by specifically trained staff only!
X						Check the engine oil level.
		X				Replace the engine oil (fill it in slowly, be sure to add the correct quantity. For a load factor above 40% or the use of engine oil that does not correspond to the required specifications, adjust the intervals accordingly. Please consult your local Perkins representative for information on the calculation of the load factor.
		X				Replace the engine oil filter.
X						Clean the air filter and empty the dust collector of the air filter, if a high accumulation of dust is caused by the operating conditions.
		X				Replace the air filter and empty the dust collector of the air filter (normal operating conditions).
			X			Clean the turbine and the compressor housing of the turbo charger. To be carried out by specifically trained staff only!
			X			Check the valve play. If necessary, adjust it. To be carried out by specifically trained staff only!
			X			Check all hoses and connections.
				X		Replace the breathers.
				X		Check the starter and the generator. To be carried out by specifically trained staff only!
				X		Make sure the wiring of the electrical system is in good condition and check for signs of wear & tear.
X						Check for engine damage and leaks (repair, if necessary).

5.2.10 HR110C-9/HR120C-9/HR140C-9: Deutz Diesel engine maintenance schedule

Prior to the operation of new / refurbished engines	after operating hours (maximum permissible period of time)						once a year	every 2 years	check	clean	replace	Required measures	to be carried out by trained service staff only
	10 or daily	250	500	1000	6000	12000							
X	X							X			Lubricant fill level; add, if required		
			X							X	Lubricant (Intervals dependent on field of application)		
			X							X	Oil filter cartridge (at each change of lubricants)		
				X						X	Fuel filter cartridge		
				X				X			Flexible fuel over flow conduits		
							X			X	Flexible fuel over flow conduits (replace completely)		
							X			X	Injection valve	X	
X								X			Preliminary fuel cleaner		
				X					X		Preliminary fuel cleaner		
X			X					X			Coolant (additive concentrate)		
							X			X	Coolant (additive concentrate)		
						X				X	Coolant pump	X	
X	X							X			Coolant pump		
X	X							X			Air intake filter (according to maintenance display)		
				X						X	Air intake filter (according to maintenance display)		
X				X				X			Charge air cooler (drain lubricant/condensed water)		
							X		X		Charge air cooler (drain lubricant/condensed water)		
				X				X			Battery and cable connections		
X				X				X			Engine control, warning system	X	
				X					X		Valve play (adjust, if necessary)	X	
				X				X			V-belt (tension or replace, if necessary)		
X							X			X	V-belt (tension or replace, if necessary)		
						X				X	Pressure retention valve at the injection pump	X	
				X				X			Crank case pressure ventilation valve	X	
						X				X	Crank case pressure ventilation valve	X	

5.3 Tires at the rear axle

5.3.1 Water filling in the tires of the rear axle

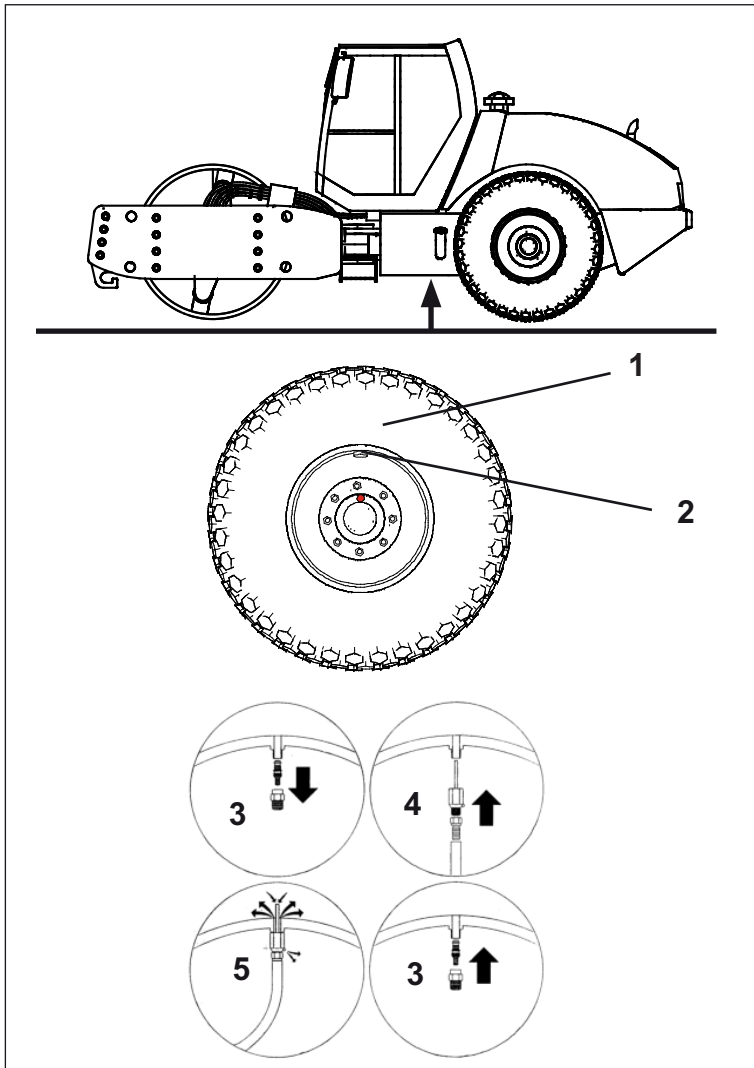

- In order to improve the propulsional properties of the tires at the rear axle, on delivery, they are filled with water and an additive composed of magnesium chloride which serves as antifreeze.



NOTE!

- Magnesium chloride is commercially available granulated salt with a 47% share of dry substance which can be purchased at (chemical) wholesale.
- In countries where the exterior temperatures never fall below 0° C, the tires can be filled with industrial water, without any additives.

Filling procedure: Water and antifreeze additive

- Lift the compaction roller at the rear axle by means of a sufficiently dimensioned hydraulic jack.
- Turn the tire (1) until the charge valve (2) is in the **top** position.
- Slowly unscrew the valve core (3).
- Screw a hose line (4) onto the charge valve.
- The saline solution (see **Preparation of the saline solution** below) can be poured into the tire (1) by means of a container placed above the tire or via a special pump.
- The filling procedure (5) must be interrupted repeatedly because the tire needs to be bled.
- In case the tire is not sufficiently filled after pouring in the saline solution, add industrial water to establish the required level.



NOTE!

Preparation of the saline solution:

- Mix magnesium chloride and water at a weight ratio of **1:1** in a clean container. Stir until the salt has completely dissolved.
- Always add the salt to the water, never vice versa.

Filling procedure: Pure water

- In order to fill the tires with water, use industrial water.
- The filling procedure is identical to the one with antifreeze additive, see instructions above.

5.3.2 Emptying the tires

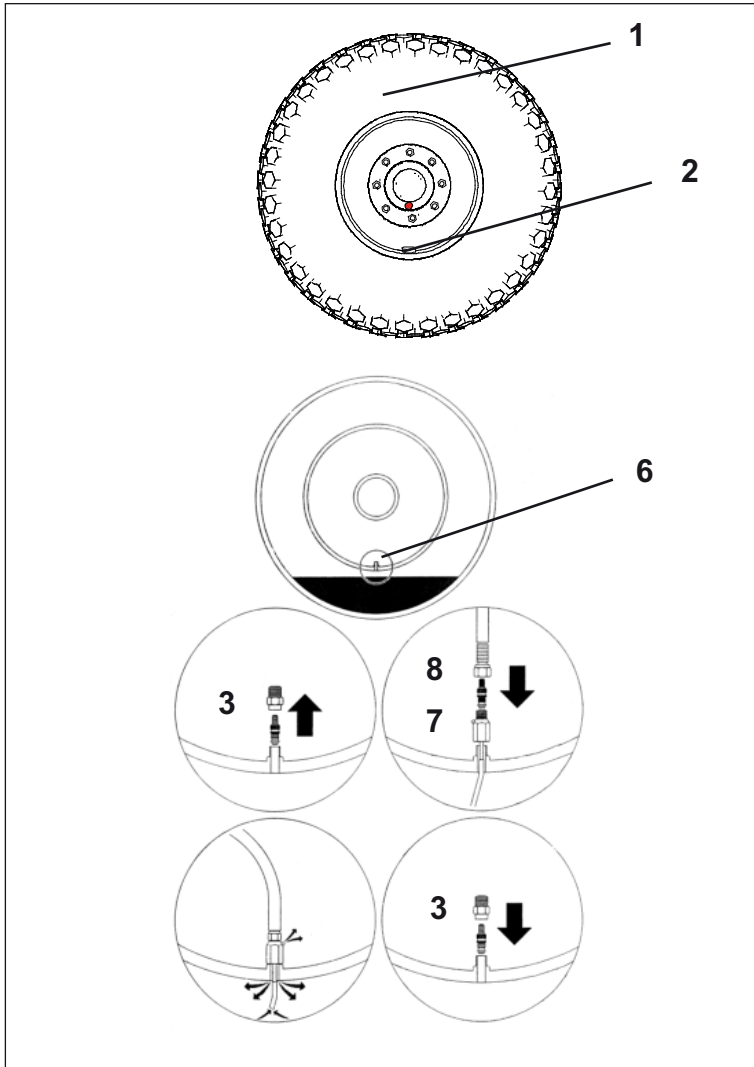

- Lift the compaction roller at the rear axle by means of a sufficiently dimensioned hydraulic jack.
- Turn the tire (1) until the charge valve (2) is in the **lowest** position.
- Slowly unscrew the valve core (3).
- Due to the overpressure in the tire, the water will be driven out of the tire, down to the level of the charge valve (6).
- Extend the vent pipe of the composite valve (7) by means of a thin rubber hose (9).
- In order to remove the remaining quantity of water from inside the tire, screw the composite valve (7) onto the charge valve (2) and charge with compressed air (8).
- The compressed air drives the remaining water out of the tire via the rubber hose (9) until it finally leaks from an opening at the side of the composite valve.
- As soon as the tire is empty, attach the valve core (3) and fill the tire (1) with compressed air. Prescribed pressure: **1.1 bar to 1.6 bar** (for standard tires).

5.3.3 Filling procedure: Using the “Hanauer Maus”

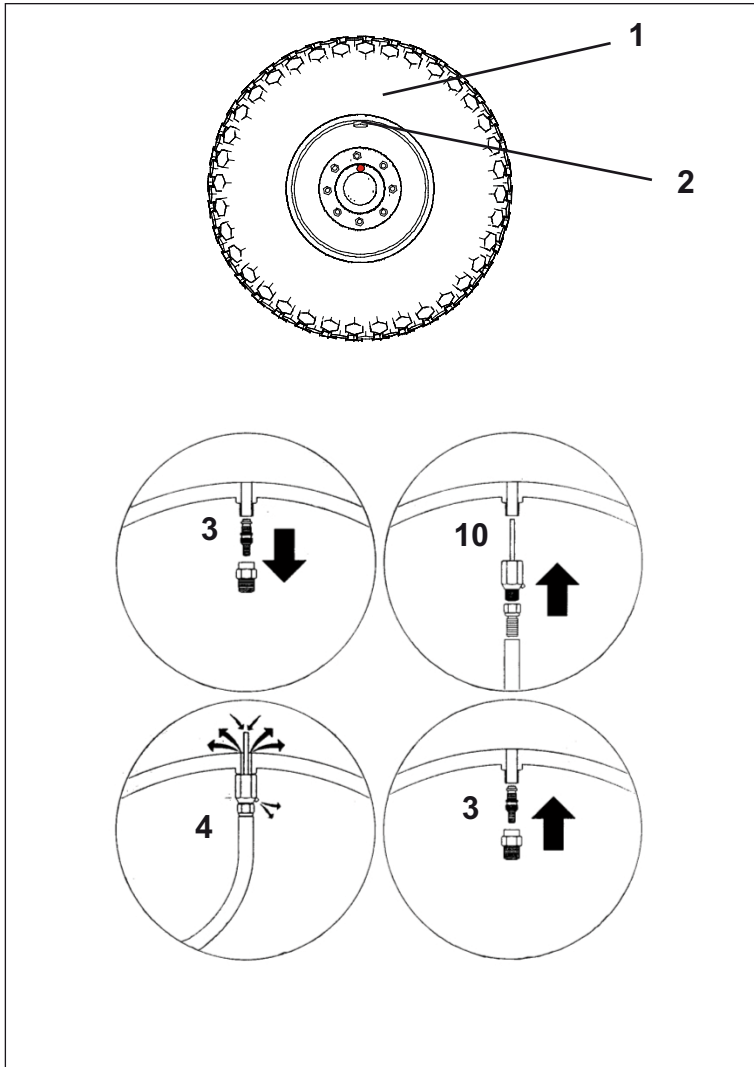

In order to fill or empty a tire by means of the so-called “Hanauer Maus”, carry out the following instructions:

- Use a sufficiently dimensioned hydraulic jack to lift the compaction roller at the rear axle.
- Turn the tire (1) until the charge valve (2) is in the **top** position.
- Slowly screw off the valve core (3).
- Screw the fill valve (10) into the charge valve (2).
- Screw a hose line (4) onto the fill valve (10).
- The air escapes from the tube and the opening at the side of the fill valve (10).



NOTE!

The filling procedure is complete as soon as a constant jet of water exits the opening.

- Twist off the fill valve (10) and tighten the valve core (3).
- At the end of the filling procedure, unscrew the fill valve (10) and screw in the valve core (3).
- Fill the tire (1) with compressed air until the required pressure of **1.1 bar to 1.6 bar** (for standard tires) has been established.

5.3.4 Checking the tire inflation pressure

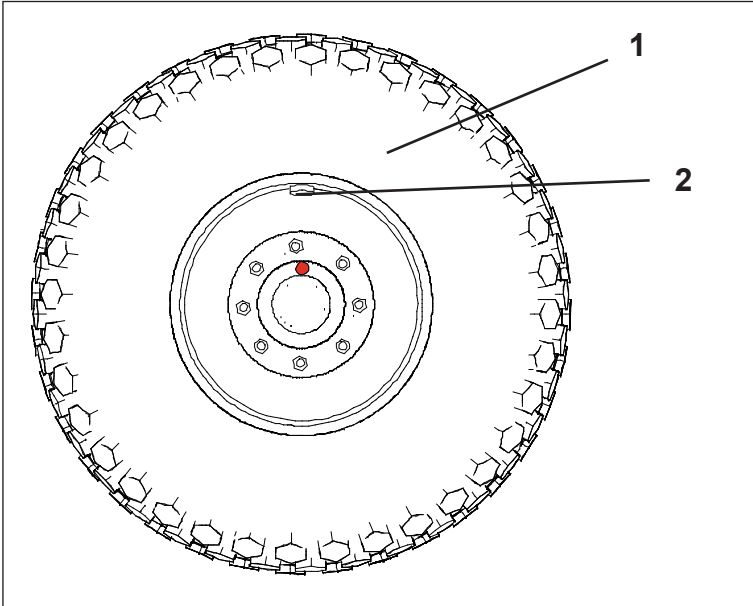

DANGER!

Risk of injuries!

Antifreeze may leak from the tire while its pressure is being checked!
This can lead to chemical burns. Wear protective clothing to protect your skin!

- Check the tire pressure once a week:

Type of tires	min. pressure	max. pressure	Note!
Standard tires	1.1 bar	1.6 bar	With water filling
Special tires	1.6 bar	2.0 bar	With water filling

Checking the tire pressure:

- In order to check the tire inflation pressure, the charge valve (2) needs to be in the top («12 o'clock») position. Move the compaction roller forward and backward to establish this position of the tires (1).
- Unscrew the safety cap of the charge valve.
- Squeeze the filler valve until there is no saline solution (or water) leaking from the valve (2) any more.



WARNING!

Material damage!

Always empty the tires and make sure no water or saline solution can leak from the charge valve before checking the tire inflation pressure. Moisture destroys the tire gauge.

- Attach the gauge and check the tire inflation pressure.
- If necessary, adjust the tire pressure.



WARNING!

Material damage!

- Have tires replaced or mounted by an authorized HYUNDAI dealer or a trained expert only.
- In order to prevent the tire from sliding on the wheel rim, the tire must not be mounted with the aid of lubricants.

- Tightening torque of the wheel nuts (2): **500 Nm**.

5.3.5 Mounting the tires



Chapter 6

Diesel engine and hydraulic system

Contents

This chapter provides you with information about:

- the technical specifications of the Diesel engine
 - the entire hydraulic system
- 

6.1 Diesel engine



NOTE!

Obligation to inform yourself!

Please refer to the operating manual of the Diesel engine manufacturer (i.e. **Deutz** or **Perkins**) for information related to the Diesel engine. The manual is part of the vehicle documentation.

6.1.1 Technical specifications Diesel engine

Compaction roller type	HR70C-9	HR110C-9	HR120C-9	HR140C-9
Make	Perkins 1104C-44	Deutz TCD 2012 L4	Deutz TCD 2012 L4	Deutz TCD 2012 L4
Type	four-stroke Diesel engine with charging and direct injection			
Nominal output	61.5 kW (84 HP)	96 kW (130 HP)	96 kW (130 HP)	103 kW (140 HP)
Max. engine speed (min ⁻¹)	2400	2300	2300	2500
Engine oil (with filter)	8 l	10 l	10 l	10 l
Cooling	liquid-cooled/cooling protection			
Diesel tank capacity (liters)	167 l	300 l	300 l	300 l

6.1.2 Maintenance overview Diesel engine



NOTE!

Obligation to inform yourself!

For information on the required maintenance work, refer to the corresponding chapter of the **operating and maintenance manual**. In addition, be sure to consult the maintenance schedule in the operating manual of the Diesel engine manufacturer (**Deutz** or **Perkins**)!

6.2 Hydraulic system



NOTE!

Obligation to inform yourself!

For information about the hydraulic system, the drum drive and the rear wheels as well as the vibration and the steering system, refer to the respective chapters of this document and the operating & maintenance manual.

6.2.1 Technical specifications hydraulic system

Type	HR70C-9	HR110/120/140C-9
Hydraulic oil tank capacity (in liters)	68	106
Hydraulic oil filter	Filter cartridge, integrated in the pump assembly	Filter cartridge, integrated in the pump assembly
Specifications Hydraulic oil	ATLAS Spezial 46 or ISO VG32/46/68. See table of lubricants.	ATLAS Spezial 46 or ISO VG32/46/68. See table of lubricants.

6.2.2 Maintenance work hydraulic system



NOTE!

Obligation to inform yourself!

Please refer to the chapters on maintenance in this document and the operating & maintenance manual for information on maintenance work related to the hydraulic system.

6.2.3 Hydraulic circuit diagram: Entire hydraulic system HR70C-9

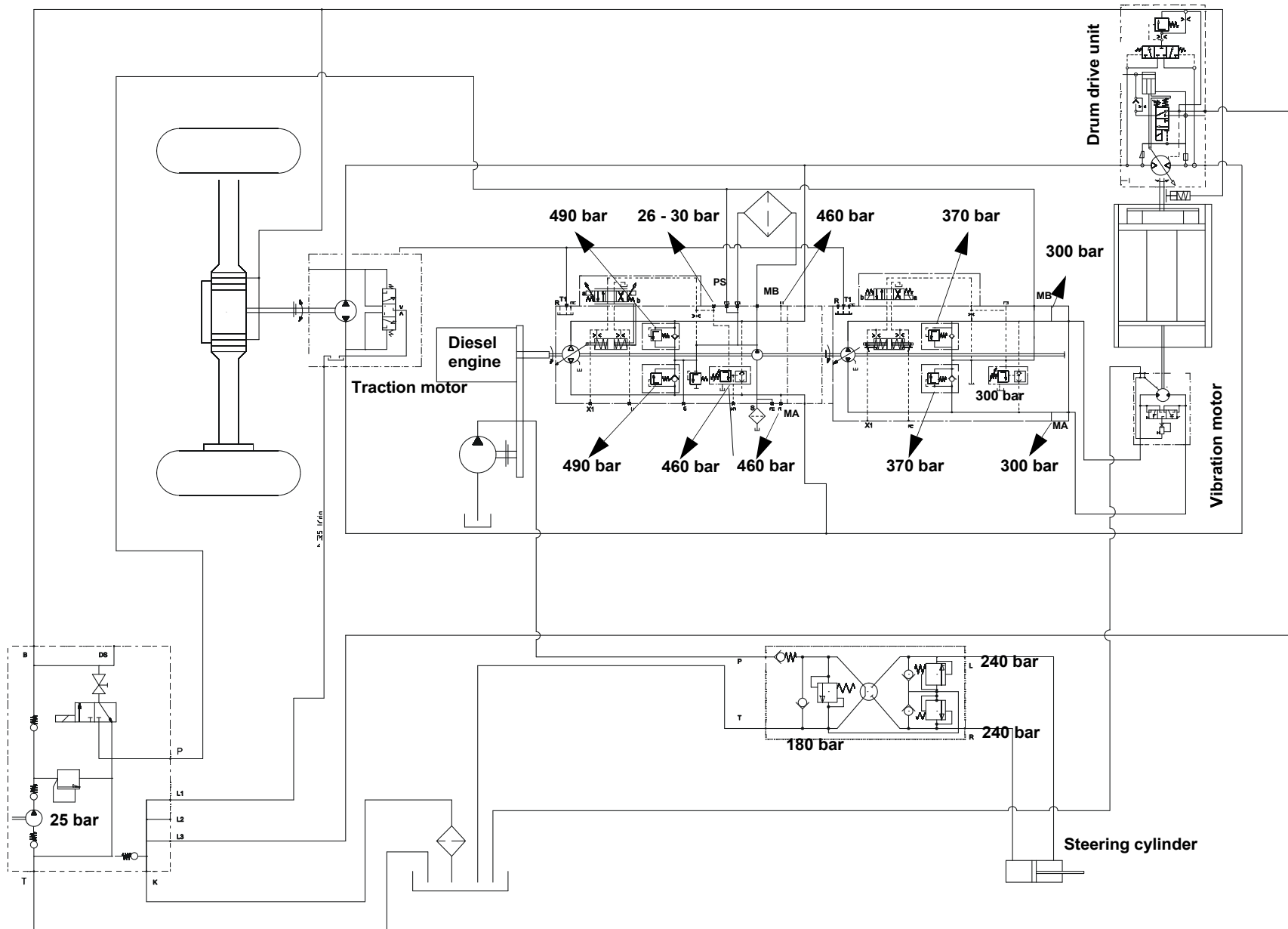

6.2.4 Hydraulic circuit diagram: Entire hydraulic system HR110/120/140C-9

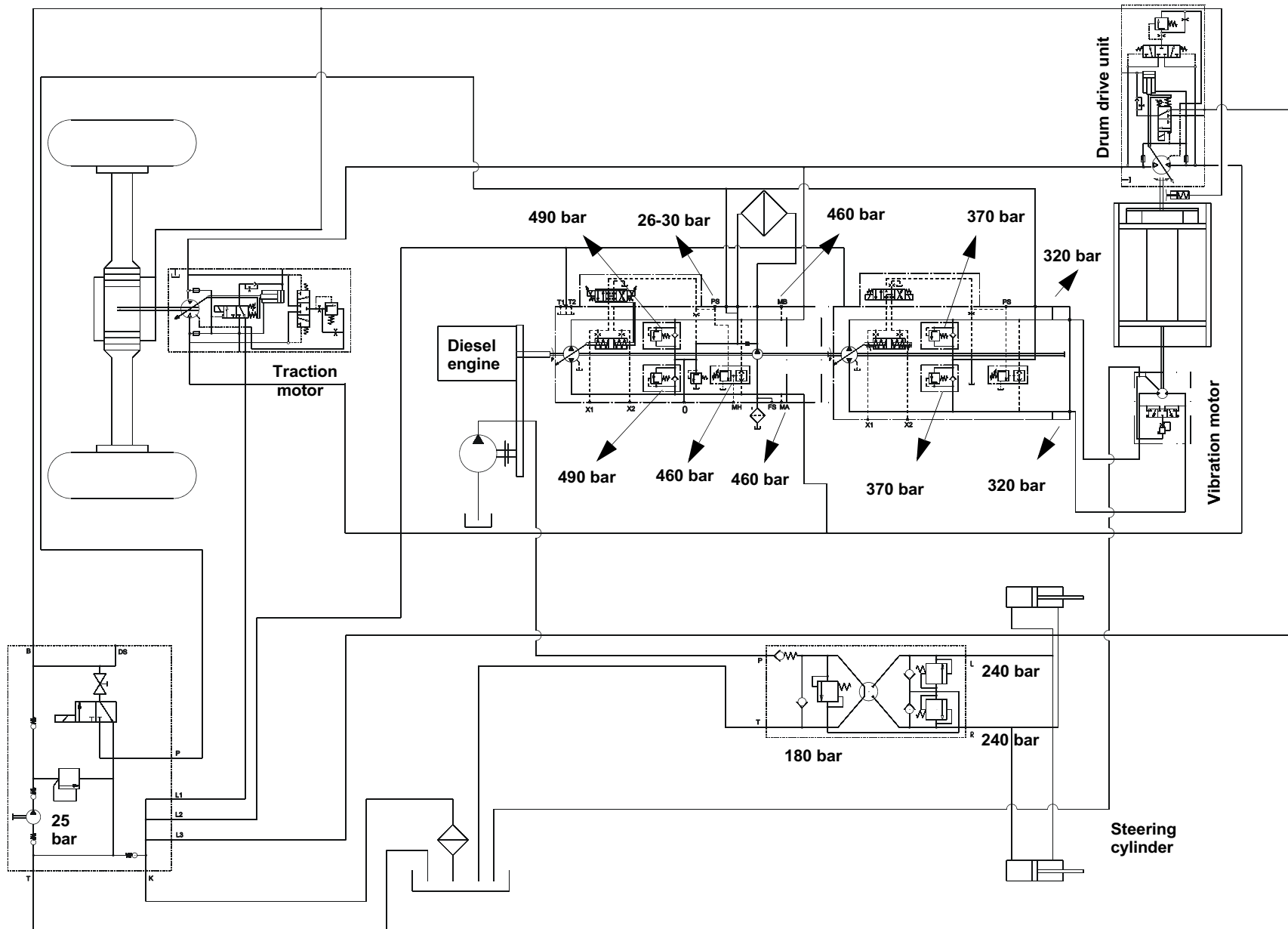



Chapter 7

Drum drive and rear axle

Contents

This chapter provides you with information about:

- the drum and its drive unit
 - the drum functions
 - trouble shooting
 - the default values
 - an overview of the measuring points
 - an overview of the options for adjustments
 - installing and dismantling the drum
- 

7.1 Drum and rear axle

7.1.1 Technical specifications drum

with smooth roller drum	HR70C-9	HR110C-9	HR120C-9	HR140C-9
Drum:				
Drum width	1700 mm	2100 mm	2100 mm	2100 mm
Drum diameter	1250 mm	1500 mm	1500 mm	1500 mm
Drum thickness	20 mm	25 mm	30 mm	30 mm
with pad foot roller drum	HR70C-9	HR110C-9	HR120C-9	HR140C-9
Drum:				
Drum width	1700 mm	2100 mm	2100 mm	2100 mm
Drum diameter	1140 mm	1390 mm	1390 mm	1390 mm
Drum thickness	15 mm	25 mm	30 mm	30 mm

7.1.2 Technical specifications rear axle

with standard tires	HR70C-9	HR110C-9	HR120C-9	HR140C-9
Type and manufacturer	DANA Spicer 602/112/ 105-100	DANA Spicer 602/112/ 105-100	DANA Spicer 602/112/ 105-100	DANA Spicer 602/112/ 105-100
Standard tires with drum	16.9-24	23.1-26	23.1-26	23.1-26
Special tires with pad foot roller drum	16.9-24 TR	23.1-26 TR	23.1-26 TR	23.1-26 TR

7.1.3 Overview: Drum

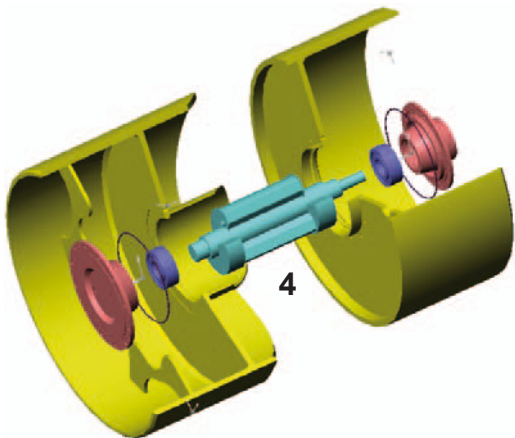
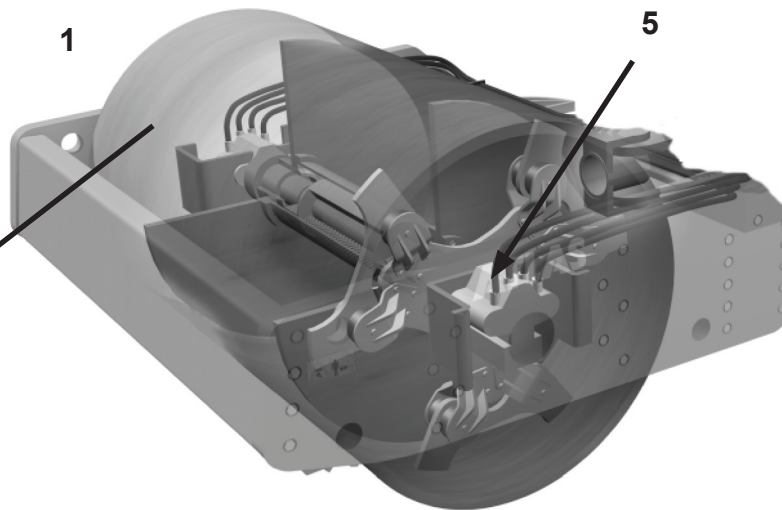

- 1 Drum
- 2 Drum drive
- 3 Vibration drive
- 4 Vibration system
- 5 Gear box drum

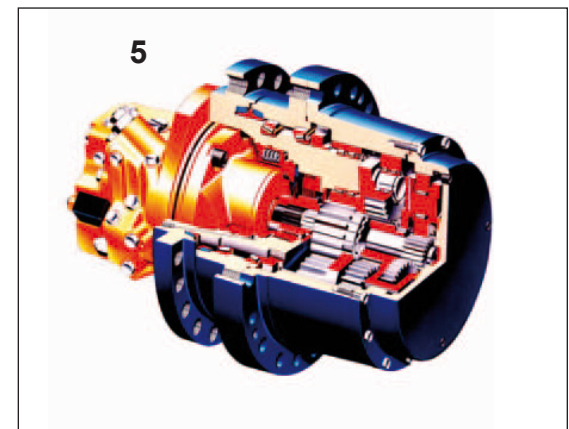

7.1.4 Overview Drive Hydraulics Drum HR70C-9, HR110/120/140C-9

HR70C-9

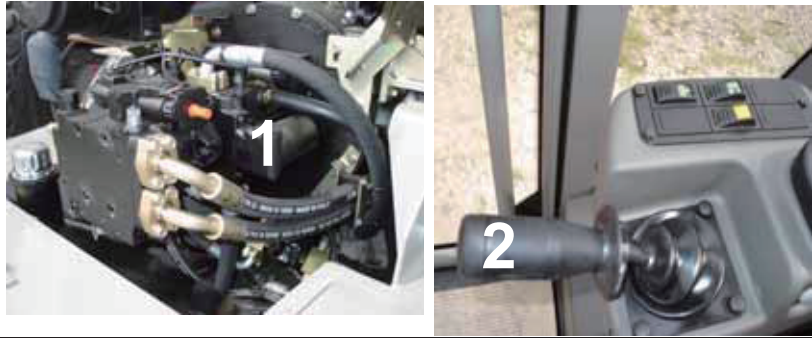

HR110/120/140C-9



- = HP oil system A & B
- = Control oil system PS
- = Tank line

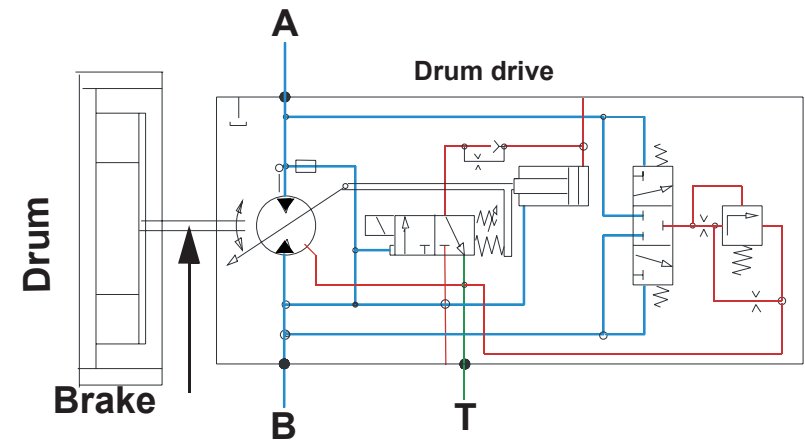
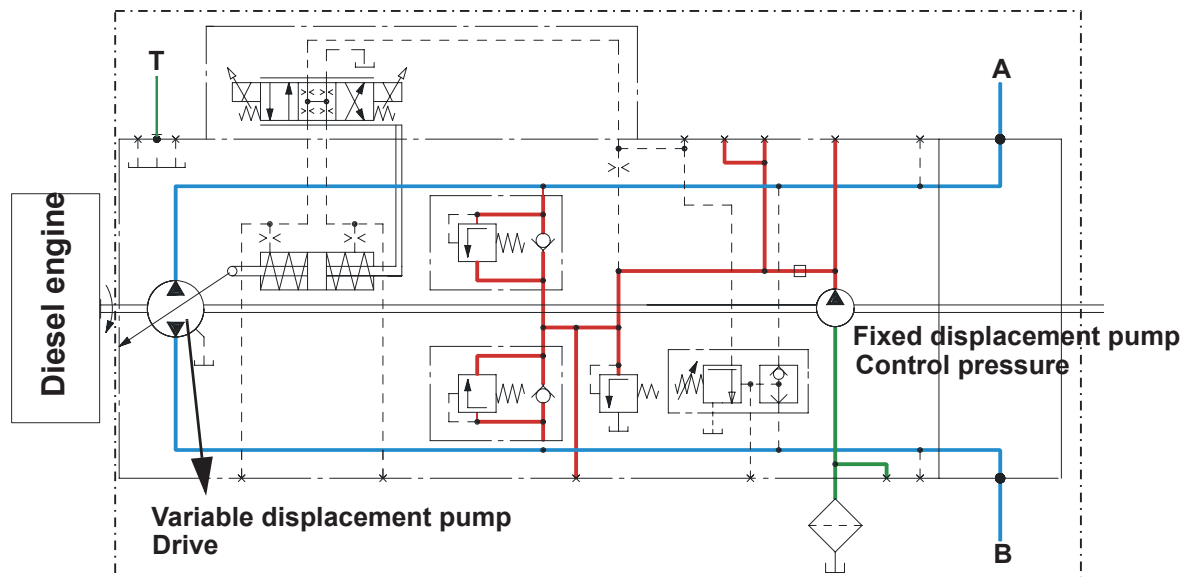

- 1 Drive adjustment pump
- 2 Control lever
- 3 Drum drive motor

7.1.5 Overview Drive Hydraulics Rear Axle HR70C-9, HR110/120/140C-9

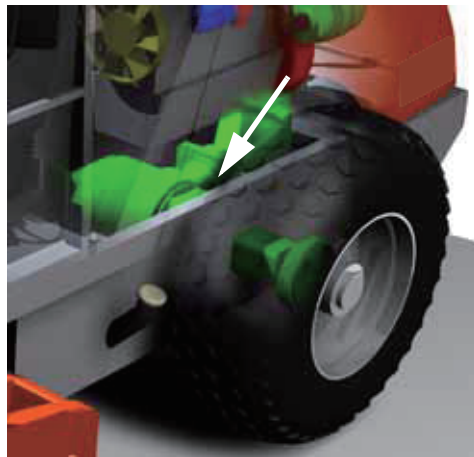

HR70C-9

Brake

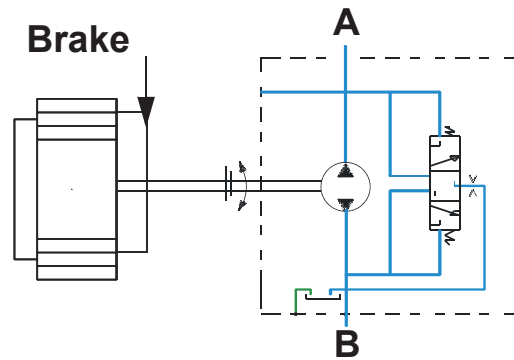

- = HP oil system A & B
- = Control oil system PS
- = Tank line

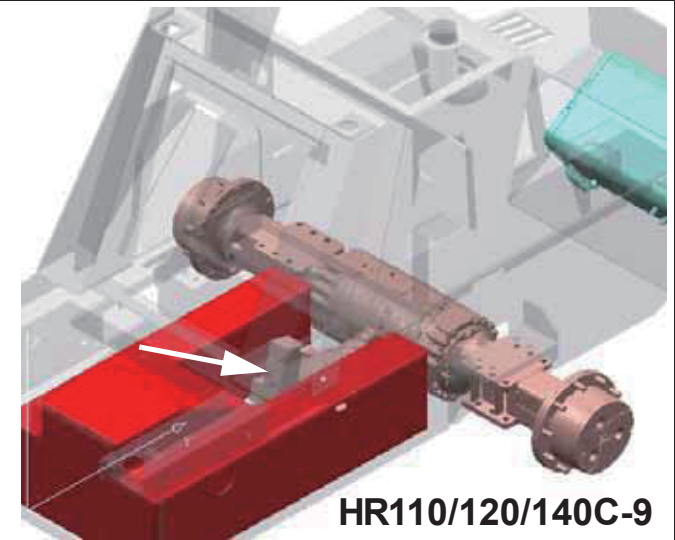
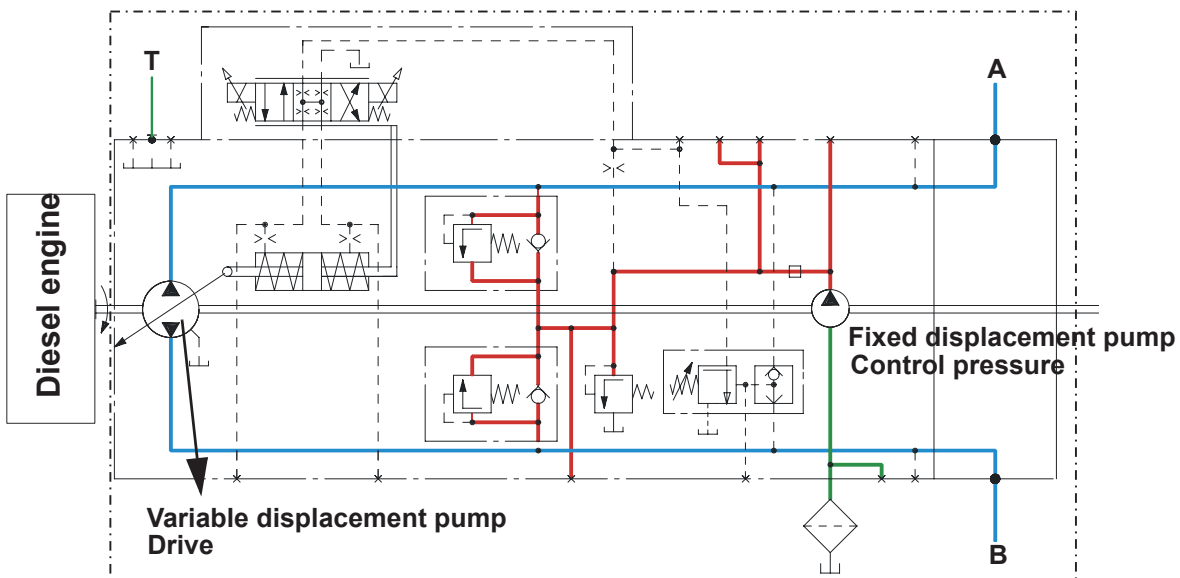

HR110/120/140C-9

Brake

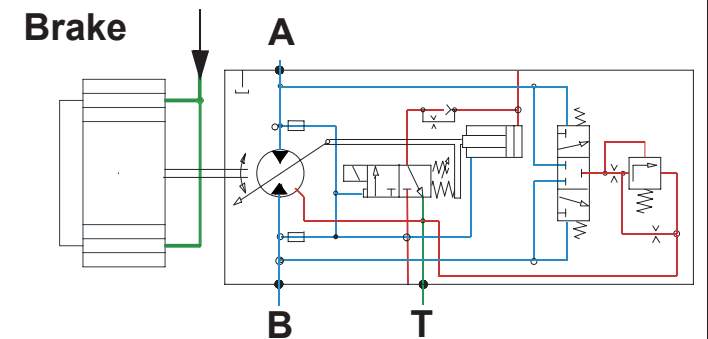

7.1.6 HR70C-9: Drive unit - Sequence of functions

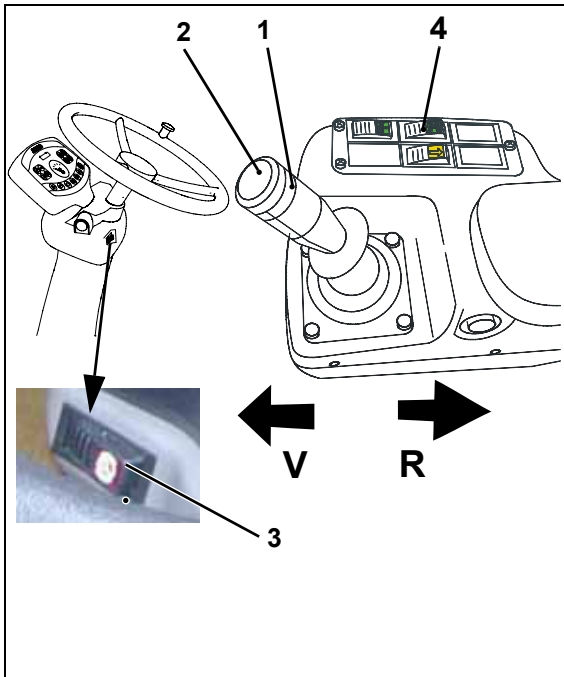

- Roller operation can be started after starting of the Diesel engine and a sufficient operating time to allow the hydraulic oil to reach its operating temperature (about 50° C).
- Release the parking brake (3); the pilot lamp in the dashboard must go out.
- Switch the speed selector switch (4) to stage 1 or 2 dependent on the required roller operation.
- Switch the vibration system on, as required, using the button (2) on the control lever.
- Move the control lever (1) to the front or rear.
- The solenoid valve for the traveling direction forward **V** or reverse **R** switches.
 - The control pressure **PS** reaches the displacement disk of the variable displacement pump.
 - The variable displacement pump swivels to the selected direction and the oil flow reaches the drum and rear axle drive units.

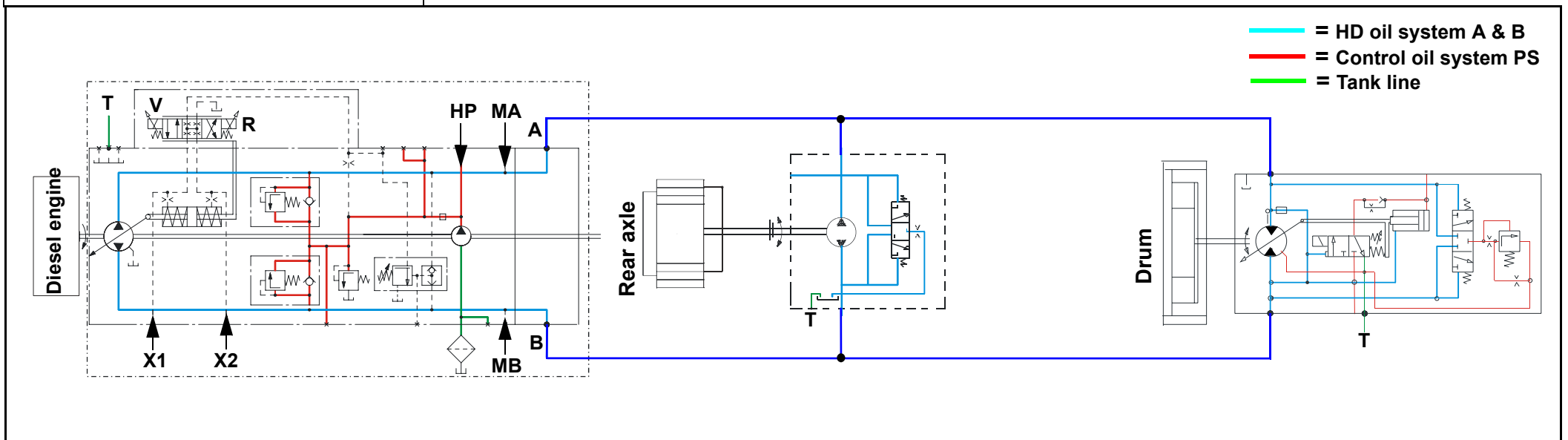

7.1.7 HR110/120/140C-9: Drive unit - Sequence of functions

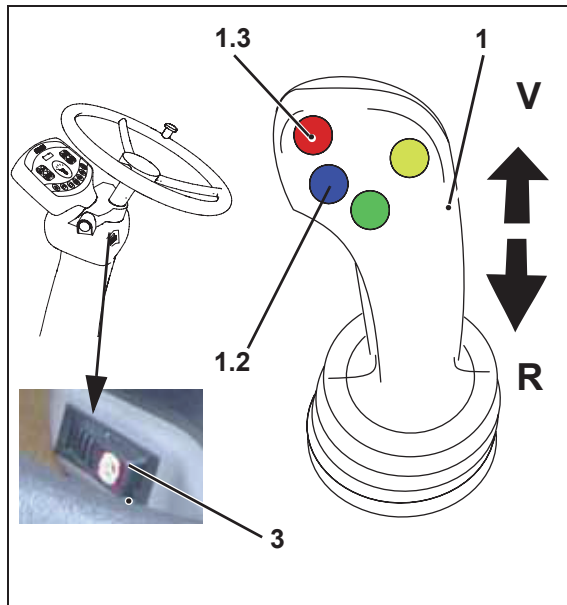

- Roller operation can be started after starting of the Diesel engine and a sufficient operating time to allow the hydraulic oil to reach its operating temperature (about 50° C).
- Release the parking brake (3); the pilot lamp in the dashboard must go out.
- Press the blue (1.2) or red (1.3) button for the Diesel engine speed.
 - Blue button (1.2) Travel without roller operation.
 - Blue button (1.3) Roller operation, with or without vibration, slope travel.
- Move the control lever (1) to the front or rear.
- The solenoid valve for the traveling direction forward **V** or reverse **R** switches.
 - The control oil pressure for the control oil pump reaches the displacement disk of the variable displacement pump for the drum/rear axle drive unit.
 - The variable displacement pump swivels to the selected direction and the oil flow reaches the drum and rear axle drive units.

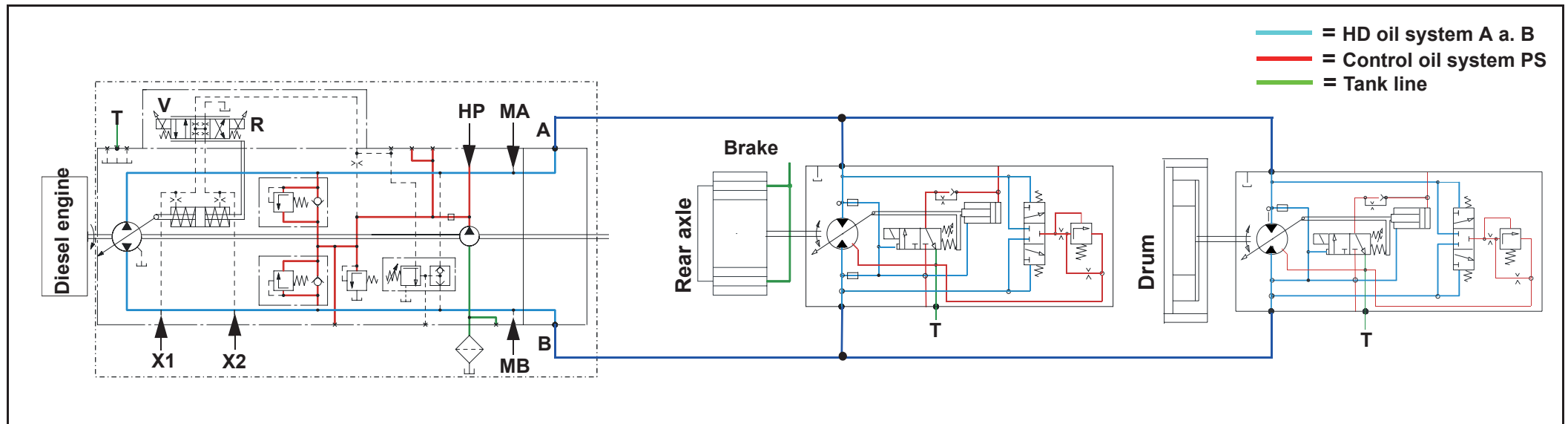

7.1.8 Trouble shooting: What to do if the compaction does not start

Failure / Problem	Causes and actions to be taken	
The vehicle does not move in the desired direction	<ul style="list-style-type: none"> • Defective contact in the electrical system • The solenoid valve fails to switch 	<ul style="list-style-type: none"> • The cable connections or the plug-in connections may be loose or defective. • Check the power supply to the solenoid valve: • Is the solenoid valve charged? • If so, does the solenoid head switch? • In case it does, repeatedly change the direction of motion by means of the joystick. • In case it does, but there is still no thrust, check the valve function, see the sections referring to the travel and vibration pump.
The compaction roller remains stationary	<ul style="list-style-type: none"> • The parking brake has not been deactivated. A warning sound is started. • The emergency actuation for the brake has not been reversed. • The HP valves have not been closed and tightened after a towing process. 	<ul style="list-style-type: none"> • Deactivate the parking brake and actuate the joystick. • Electrical fault related to deactivating the parking brake. See chapter Electrical installation. • If, in spite of carrying out the measures above, the compaction roller still does not move, check the position of the relief valve in the hand pump block. • The solenoid valve for determining the direction of motion may be defective, see instructions above. • Insufficient charge pressure. Check the pressure at measuring point PS. • Check the high pressure A and B at measuring points MA/MB.
The drum loses ground contact (i.e. jumps)	<ul style="list-style-type: none"> • The ground is too hard. 	<ul style="list-style-type: none"> • The compaction limit of your vehicle has been reached. Stop the compaction process.

Failure / Problem	Causes and actions to be taken	
<p>The drum or the wheels starts slipping on slopes or on wet grounds.</p> <p>a) The drum keeps skidding, with the rear wheels stopped.</p> <p>b) Wheelspin of the rear wheels, but the drum stops spinning.</p>	<ul style="list-style-type: none"> • The HA control function serves to prevent the drive from slipping <p>a) if there is a risk of the drum or/and the rear wheels sinking into the ground while driving along heavy terrain</p> <p>b) whenever inclinations (driving on slopes) increase the driving resistance.</p> <p>If the driving resistance on slippery or wet grounds or operation on extreme slopes prevents you from resuming operation, the HA control reduces the engine speed until the compaction roller comes to a stop.</p>	<p>In certain situations, such as</p> <ul style="list-style-type: none"> • setting the compaction roller into motion with the drum or the rear wheels sunk into the ground <p>or</p> <ul style="list-style-type: none"> • driving at a carefully set, re-tuned speed, <p>it may be necessary to override the HA control. In order to do so, deactivate the HA control of the drum or the rear axle by means of the corresponding switches („Overmodulation hydraulic motor drum / rear axle“, see the respective chapter).</p> <p>As a result, the maximum driving torque is set at the drum and the rear wheels (in accordance with the selected switch settings).</p>

7.1.9 Speeds, hydraulic measuring and adjustment values for compaction rollers

Measurement/Adjustment	Adjustment values HR70C-9	Adjustment values HR110/120C-9	Adjustment values HR140C-9	Measuring point
Diesel engine idling speed min.	950 - -1,000 min ⁻¹	900 min ⁻¹	900 min ⁻¹	Diesel engine
Supply pressure	26 bar	26 bar	26 bar	HP
Diesel engine idling speed max.	2300 - -2,400 min ⁻¹	2,300 min ⁻¹	2,500 min ⁻¹	Diesel engine
Supply pressure	30 bar	30 bar </td <td>30 bar</td> <td>HP</td>	30 bar	HP
Diesel engine speed max.	2100 - -2,200 min ⁻¹	2,200 min ⁻¹	2,400 min ⁻¹	Diesel engine
Traveling drive forward	460 bar	460 bar	460 bar	MA
Diesel engine speed max.	2100 - -2,200 min ⁻¹	2,200 min ⁻¹	2,400 min ⁻¹	Diesel engine
Traveling drive reverse	460 bar	460 bar	460 bar	MB
Roller speed max.	6.21 mi/h 50 m in 17s -19 s	7.46 mi/h 50 m in 14s - 16s		Test track/Stop watch

7.1.10 Overview of the measuring points and prerequisites of measurement

HP

MB

MA

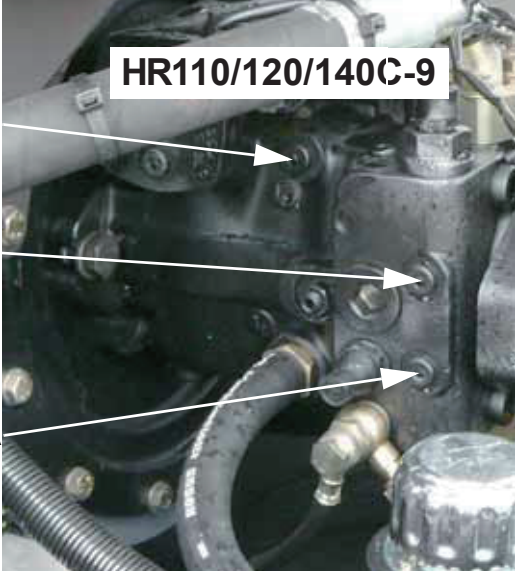

HR110/120/140C-9





HR70C-9

⚠ ATTENTION!
To enable measurement of the speeds and hydraulic oil pressures the Diesel engine must have reached its operating pressure and the hydraulic oil 50° C min. in the supply circuit.

i NOTE!
Determining the maximum roller speed:
Travel a defined distance of 50 m at a max. roller speed reached before.
Measure the time required with stop watch.

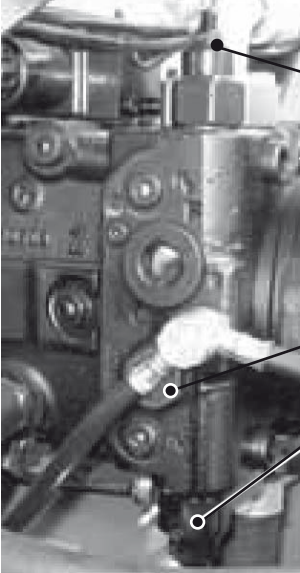
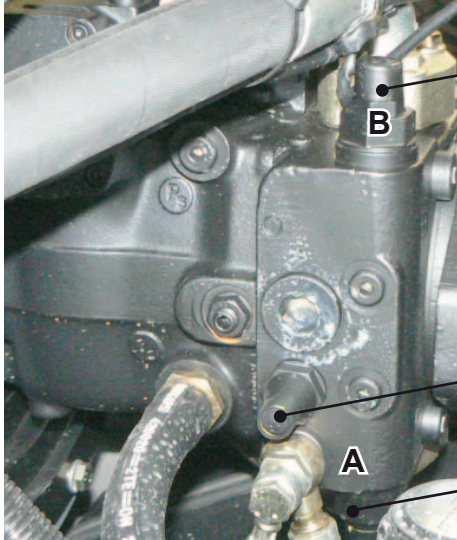
7.1.11 Overview: Adjustments at the oil pressure pump of the drum drive

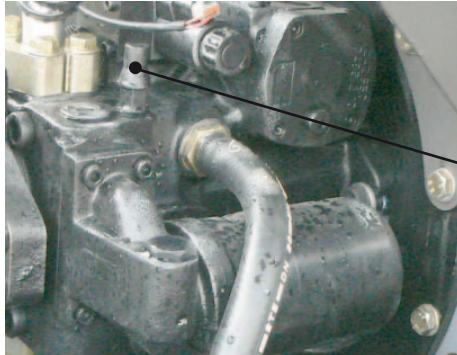
HR70C-9	HR110C-9/HR120C-9/HR140C-9
 <p>HP valve 490 bar</p> <p>PS control/charge pressure settings</p> <p>HP valve 490 bar</p>	 <p>HP valve 490 bar</p> <p>B</p> <p>PS control/charge pressure settings</p> <p>A</p> <p>HP valve 490 bar</p>
 <p>Pressure cut-off 460 bar</p>	 <p>Pressure cut-off 460 bar</p>



Chapter 7.2

Installing & dismantling the drum

Contents

This chapter provides you with information about:

- the roller drum and its drive unit,
 - the rear axle and its drive unit,
 - the functions and trouble shooting,
 - the measuring points and default values.
 - an overview of the measuring points,
 - an overview of the adjustment options
- 

7.2.1 Preparing the drum for repair work

Preparing the roller for drum removal and installation



ATTENTION!

The drum may only be removed in a workshop.
Sufficient crane capacity must be available to lift the drum frame and the drum.

- Secure the roller against rolling before starting work.
- Pull the ignition key.
- Insert the anti-buckling device (1) between the drum frame and the basic frame.
- Wedge the rear wheels appropriately.
- Attach the drum frame via lifting gear to a crane.
- Lift the drum frame so that the drum and the rubber buffer are released from load.
- Place supports under the drum frame at the front and at the rear.
- Place oilpans under the drum drive and under the vibration drive.

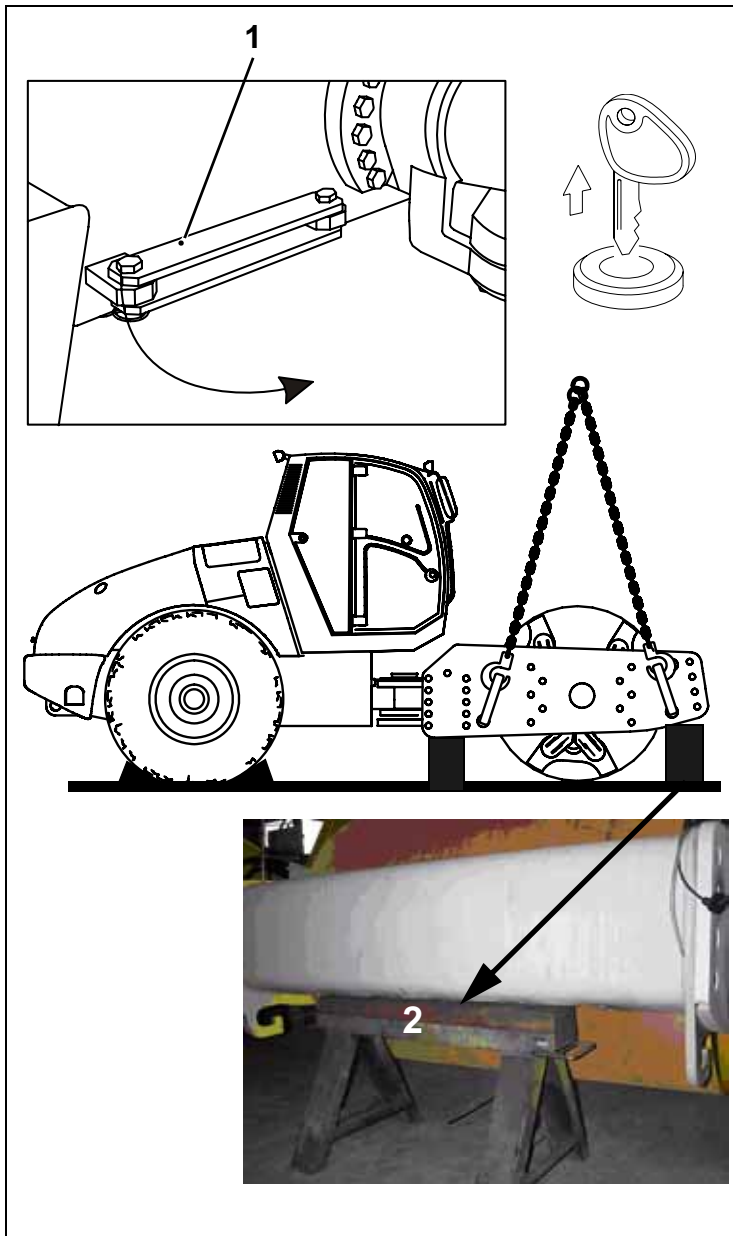

7.2.1.1 Overview Drum

Drum HR70C-9

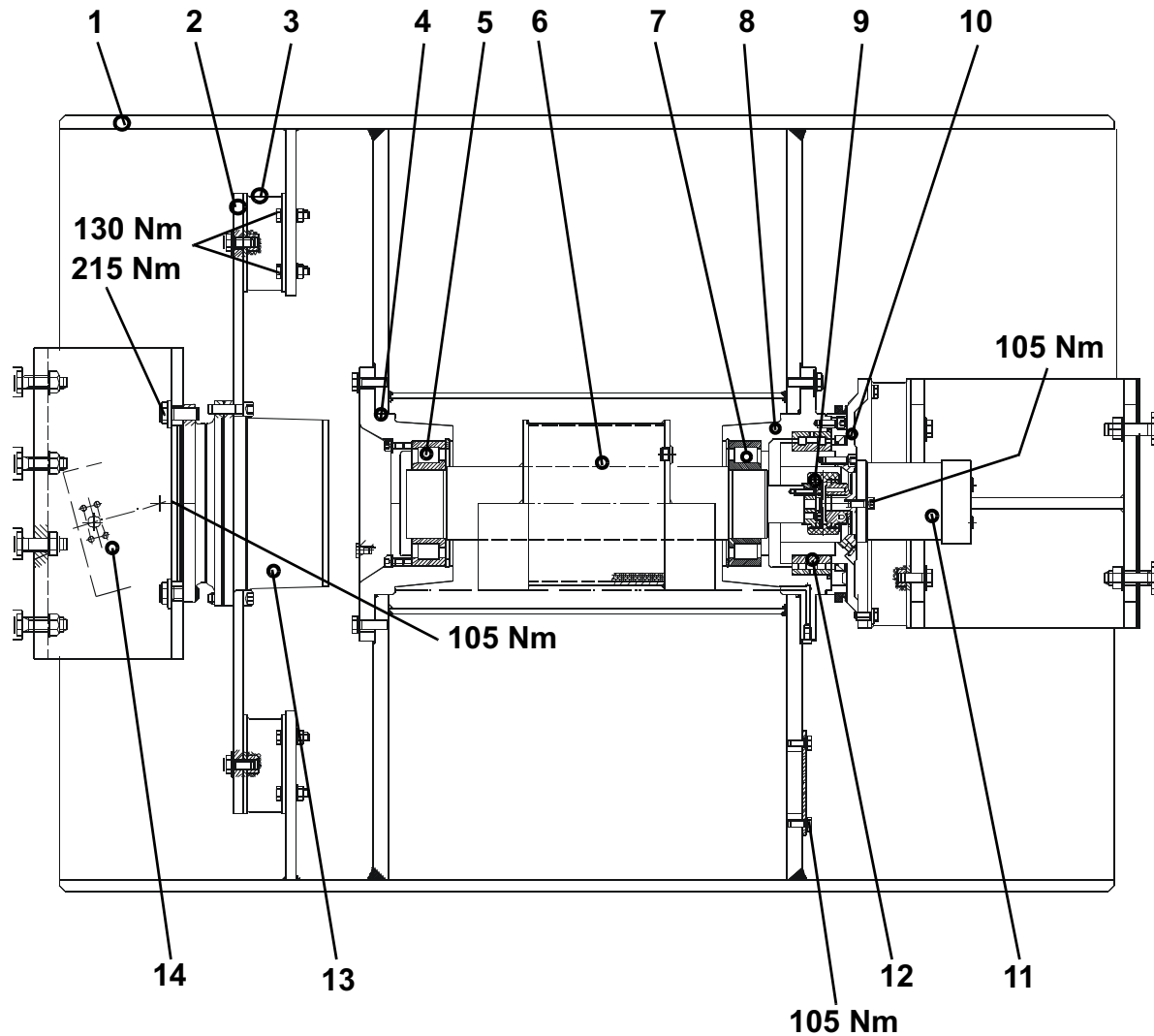

- 1 Drum
- 2 Drive system
- 3 Rubber buffer
- 4 Bearing housing
- 5 Cylinder roller bearing
- 6 Vibration shaft
- 7 Cylinder roller bearing (drive bearing)
- 8 Bearing housing
- 9 Clutch
- 10 Side plate
- 11 Vibration motor
- 12 Bearing
- 13 Drum drive/gear unit
- 14 Drum drive hydraulic motor



NOTE!

Please refer to the table 'Tightening torques' in chapter 1 for tightening torques and screw joints not specified here in the drawing.

Drum HR110/120/140C-9

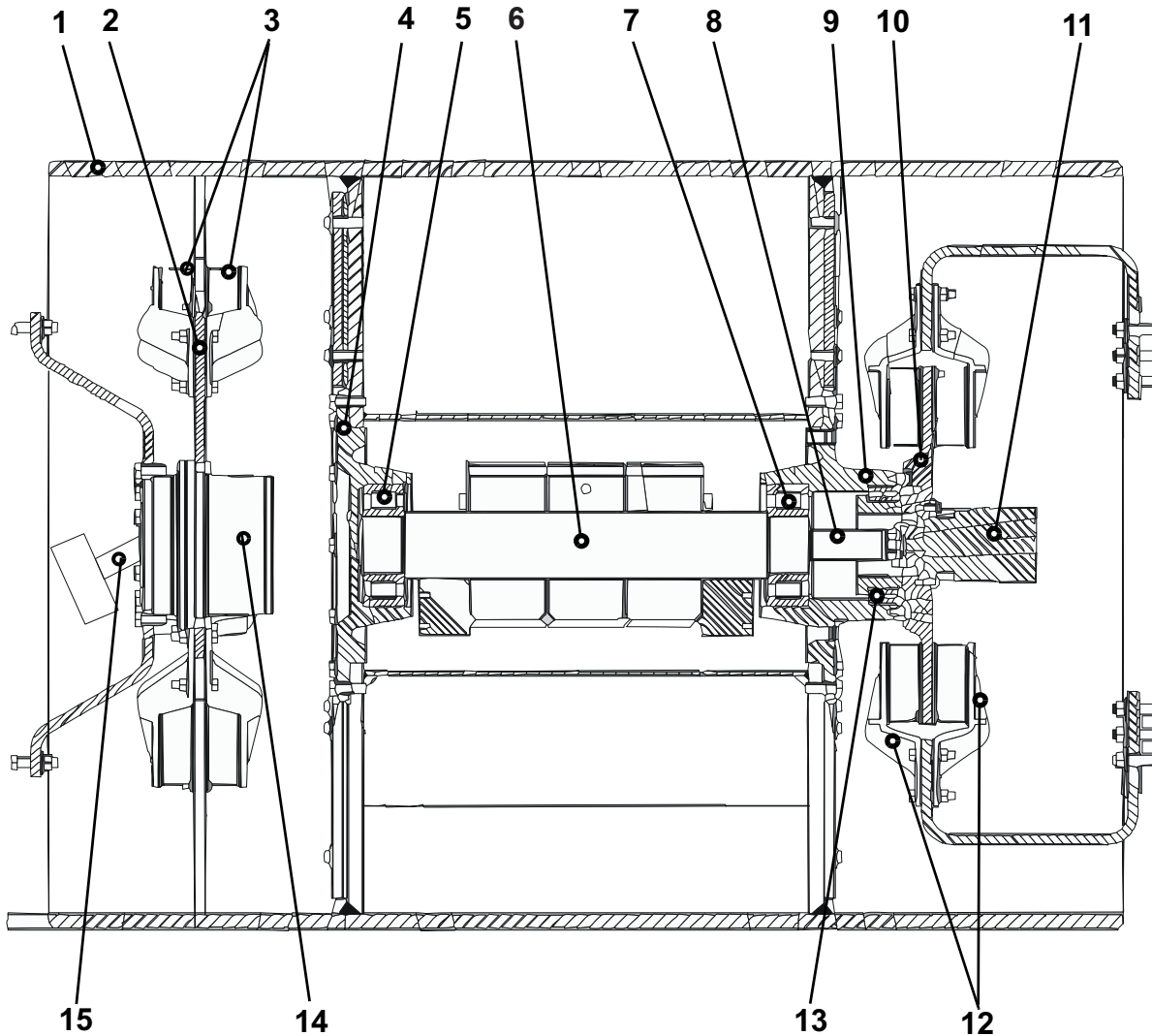

- 1 Drum
- 2 Drive system
- 3 Rubber buffer
- 4 Bearing housing
- 5 Cylinder roller bearing
- 6 Vibration shaft
- 7 Cylinder roller bearing (drive bearing)
- 8 Clutch
- 9 Bearing housing
- 10 Side plate
- 11 Vibration motor
- 12 Buffer bracket
- 13 Cylinder roller bearing
- 14 Drum drive/gear unit
- 15 Drum drive hydraulic motor



NOTE!

Please refer to the table 'Tightening torques' in chapter 1 for tightening torques and screw joints not specified here.

Drum HR110/120/140C-9

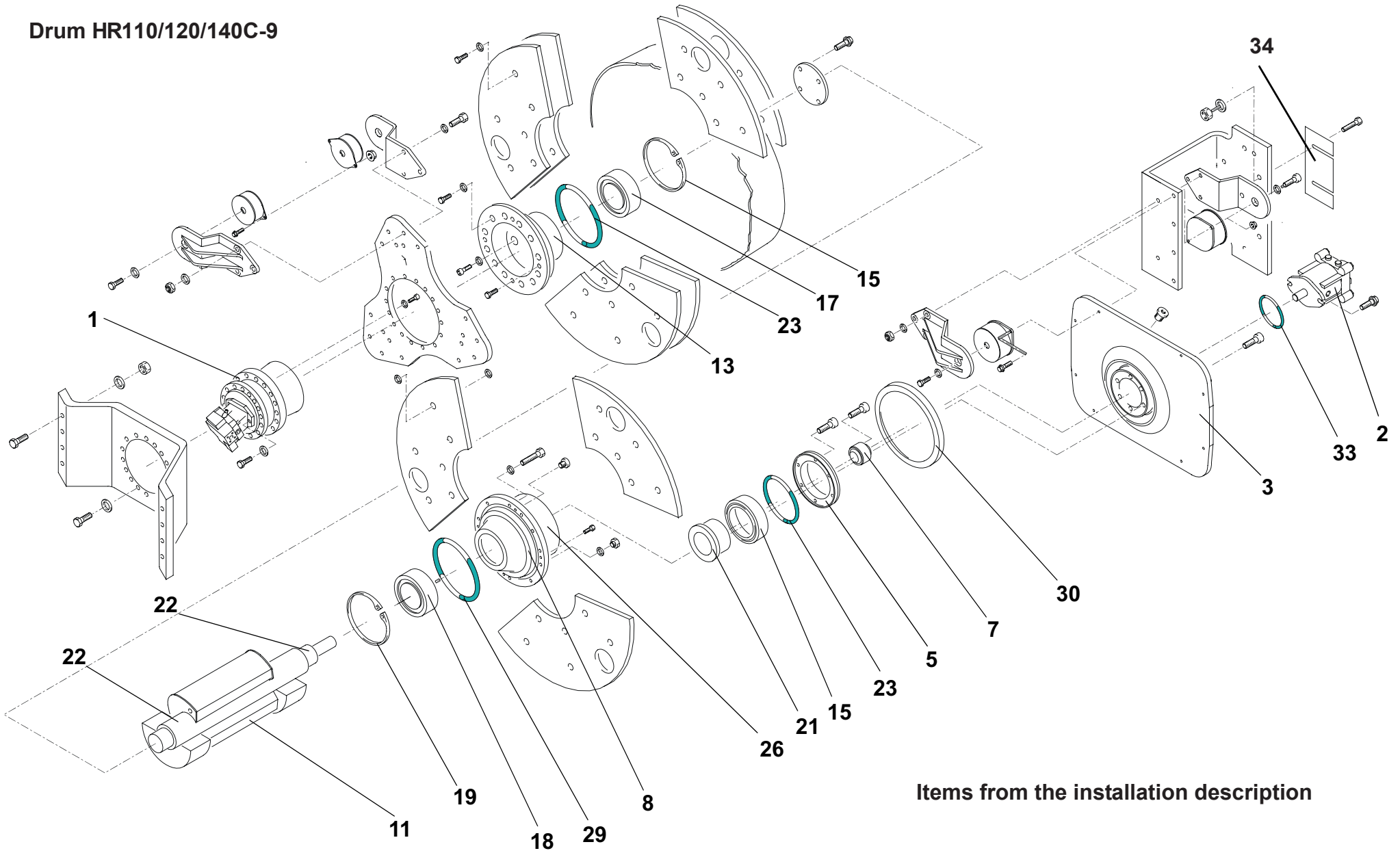

Items from the installation description

7.2.2 Removing the drum

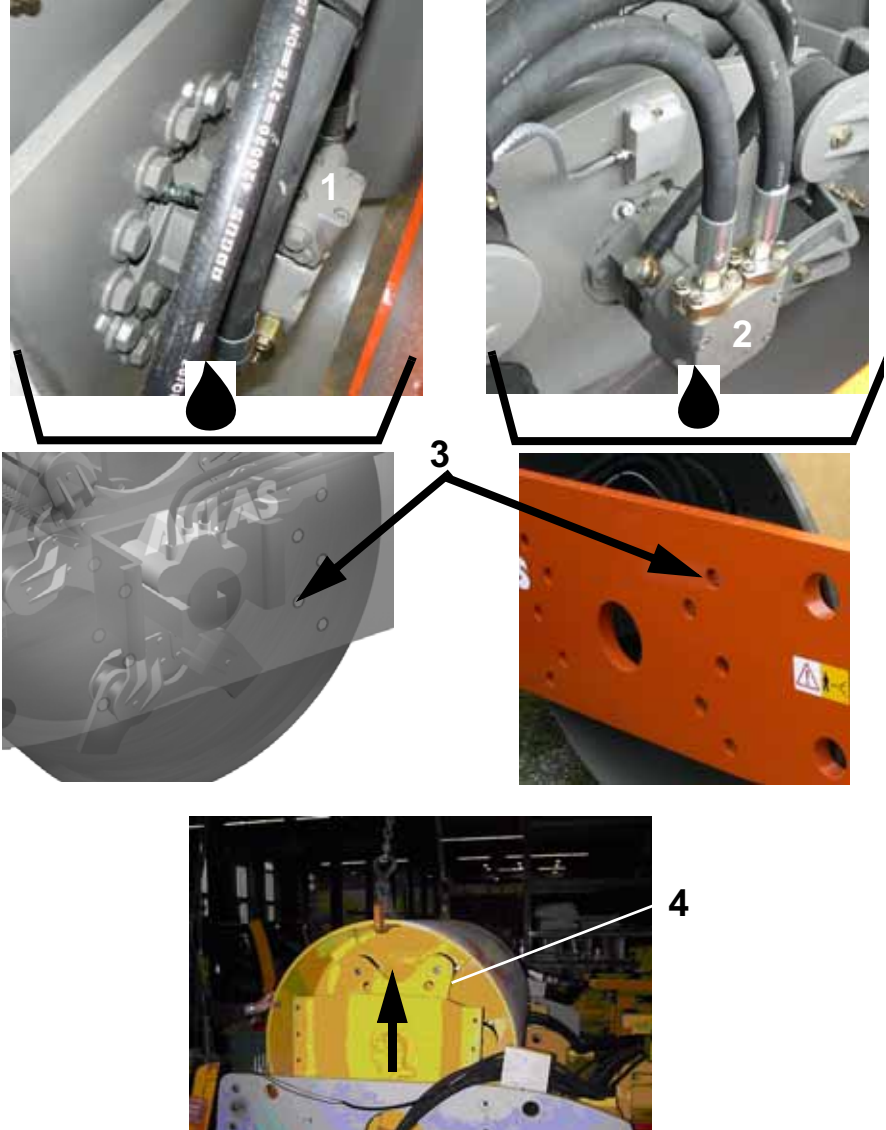
Figure	Work to be executed
 <p>The figure consists of four photographs illustrating the process of removing the drum. The top-left photo shows a hydraulic hose with a black arrow pointing to a marking point labeled '1'. The top-right photo shows a hydraulic connection being detached from a vibration drive, with a black arrow pointing to the connection labeled '2'. The bottom-left photo shows a grey metal adapter with a black arrow pointing to a bolt labeled '3'. The bottom-right photo shows an orange metal frame with a black arrow pointing to a bolt labeled '3'. The bottom-center photo shows the drum being lifted upwards by a crane, with a black arrow pointing to the drum labeled '4'.</p>	<p>Work to be executed</p> <ul style="list-style-type: none">• Mark the hydraulic connections.• Detach the hydraulic connections from the drum drive (1) and from the vibration drive (2).• Detach brake connection from gear motor.• Be aware of hydraulic oil flowing out.• Immediately close the hydraulic hoses and connections in the drives with sealing plugs.• Using a crane and lifting hooks lift the drum (4) so far that the rubber buffers are released from load.• Remove the bolts between frame and buffer bracket on the vibration drive side.• Remove the bolts (3) between frame and adapter on the drum drive side.• Using a crane and lifting hooks lift the drum (4) upwards out of the frame.

7.2.3 Dismantling the drum

Figure

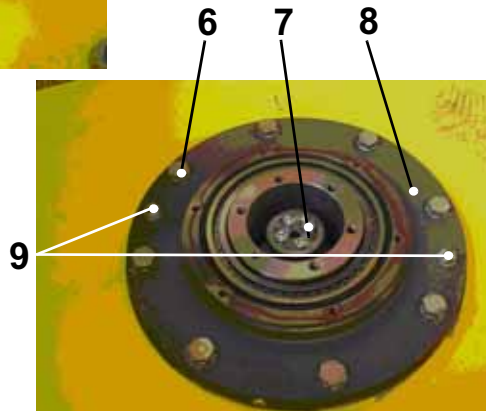
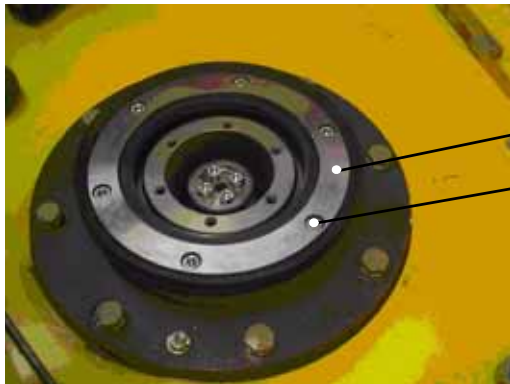
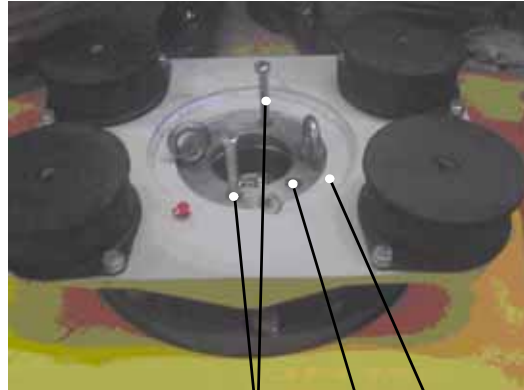

Work to be executed

- To remove the vibrator shaft lift the drum on the vibration drive side with a crane and place it vertically up.
- Erect a working platform beside the drum.
- Turn the bolts (2) out of the side plate (3).
- Turn forcing screws (1) into two opposite threads until the side plate (3) can be removed.
- Turn the six cheese-head screws (4) out of the bearing cover (5).
- Remove the bearing cover (5) with the shaft sealing ring.
- Turn the bolts (6) out of the bearing housing (8).
- Loosen the bearing housing using the forcing screws (9).
- Remove the bearing housing (8).
- Unscrew the clutch (7) from the shaft.

Figure

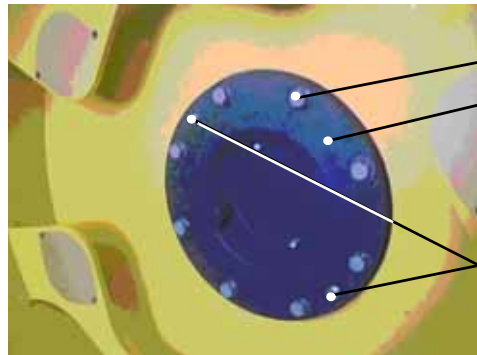
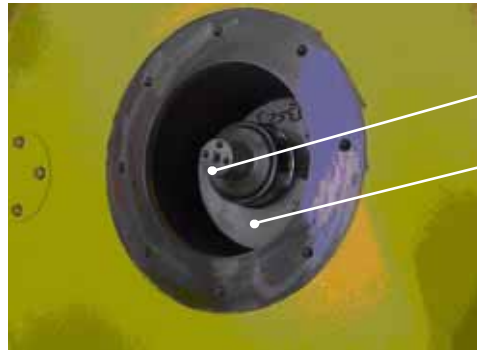

Work to be executed

- Turn an eyebolt into the marked tap hole (10).
- Using a crane lift the shaft (4) out of the drum.
- To remove the components on the drum drive side lift the drum on the vibration drive side with a crane, rotate it through 90° and place it vertically up.



WARNING!

Observe pollution control criteria!

The chamber of the vibration unit contains oil. Remove the oil before turning the drum again.

- Fasten the drum again on the drive side, lift and place it upright.
- Erect a working platform beside the drum.
- Turn all bolts (14) out of the bearing housing (13).
- Turn the forcing screws (12) in and force the bearing housing (13) out of the drum.

7.2.4 Removing the bearing

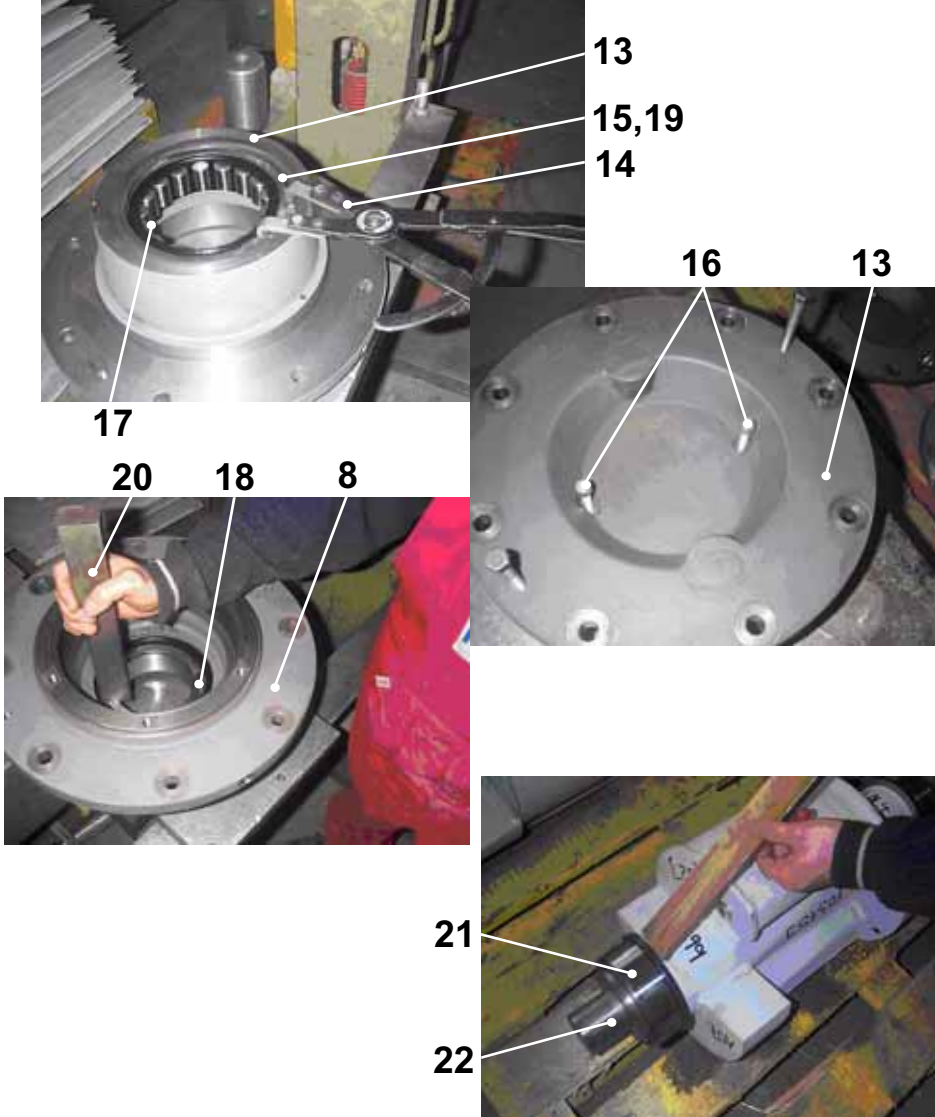
Figure	Work to be executed
 <p>The figure consists of four photographs illustrating the process of removing a bearing. 1. Top-left: A bearing housing (13) is shown with a retainer (15) being compressed by circlip pliers (14) to remove a bearing (17). 2. Top-right: A bearing housing (13) is shown with two forcing screws (16) inserted into its tap holes. 3. Bottom-left: A bearing housing (8) is shown with a retainer (19) being compressed by circlip pliers (14) to remove a bearing (18) using a mandrel (20). 4. Bottom-right: A hand is shown using a mandrel (21) to pull an inner bearing ring (21) off a shaft journal (22).</p>	<p>Removing the bearing housing on the drum drive side:</p> <ul style="list-style-type: none"> • Deposit the bearing housing (13) on a workbench. • Compress and remove the retainer (15) with circlip pliers (14). • Rotate the bearing housing through 180°. • Turn two forcing screws (16) into the tap holes of the bearing housing (13) and force the bearing (17) out of the bearing housing. <p>Removing the bearing housing on the vibration drive side:</p> <ul style="list-style-type: none"> • Deposit the bearing housing (8) on a workbench. • Compress and remove the retainer (19) with circlip pliers (14). • Rotate the bearing housing (8) through 180°. • You must beat the bearing (18) out of the bearing housing (8) using a mandrel (29). <p>Pulling the bearing rings off the shaft journal:</p> <ul style="list-style-type: none"> • Force the inner bearing rings (21) off the journal (22) using a mandrel.

7.2.5 Installing the bearing

Figure	Work to be executed
<p>The figure consists of three photographs illustrating the bearing installation process. The top photograph shows a shaft (11) with bearing journals (22) and inner bearing rings (21). The middle photograph shows cylinder roller bearings (17,18) being pressed into bearing housings (8,13). The bottom photograph shows retaining rings (15,19) being inserted into the bearing housings.</p>	<div data-bbox="1115 320 2152 512" style="background-color: yellow; padding: 10px;"> <p>⚠ DANGER! <i>Danger of burns by hot components!</i></p> <ul style="list-style-type: none"> Some bearings are fitted in heated state, wear gloves for all work. </div> <p>Fitting new bearing rings on the shaft journal:</p> <ul style="list-style-type: none"> Heat the inner bearing rings (21) in an oil bath to about 100°C and press them onto the bearing journals (22) of the shaft (11). <p>Inserting new cylinder roller bearings and retaining rings:</p> <ul style="list-style-type: none"> Press new cylinder roller bearings (17,18) into the respective bearing housings (8, 13) using a hydraulic press and an intermediate plate. Insert the retaining rings (15, 19) into the respective bearing housings so that they snap in.

Figure

Work to be executed



Inserting a new shaft sealing ring:

- Press the shaft sealing ring (23) out of the bearing cover (5).
- Slightly grease the sealing lip of the new sealing ring.
- Insert new shaft sealing ring (23) with the sealing lip up into the bearing cover (5) and force it in up to the stop using a push-in device.

Inserting a new drive bearing into the bearing fixture:

- Press bearing fixture (26) out of the drive bearing (25) using a plate (24).
- Place new drive bearing (25) on the bearing fixture (26).
- Press drive bearing (25) onto the bearing fixture (26) up to the stop using a push-in device (27).
- Insert bearing fixture (26) with the drive bearing (25) into the bearing housing (8) in such a way that the tap holes of the bearing fixture point upwards..
- Press bearing fixture (26) into the bearing housing (8) until they make contact using the push-in device (27).

7.2.6 Assembling the drum

Figure	Work to be executed
	<p>Installing the bearing housing of the drum drive side</p> <ul style="list-style-type: none"> • Apply sealing compound Loctite 518 to the sealing face (28) of the drum. • Slightly grease O ring (29) and fit it on the bearing housing (13). • Put bearing housing (13) on the sealing face (28) on the drum drive side. • Using the screws (14) pull the bearing housing (13) in up to the stop. • Retighten screws (14) using a torque wrench. • Close the forcing holes (12) by means of screws. • To install the components on the vibration drive side lift the drum on the drum drive side with a crane, rotate it through 90° and put it down on the drum circumference. • Fasten the drum again on the vibration drive side, lift and place it upright. • Erect a working platform beside the drum.

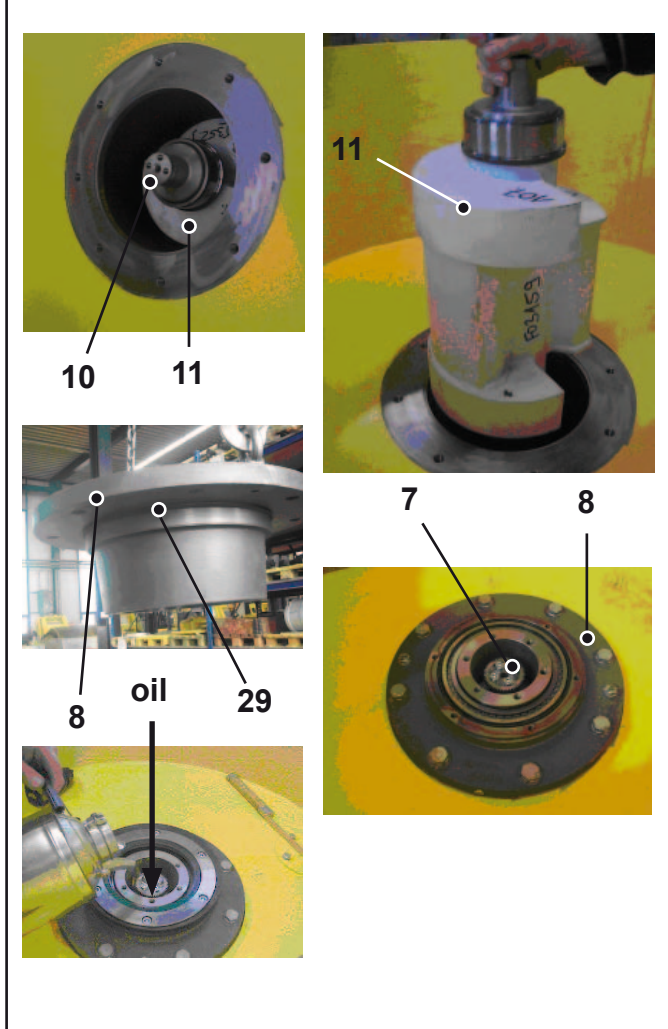

Illustration	Maintenance measures
	<p>Installing the vibration shaft and the bearing case on the vibration drive side:</p> <ul style="list-style-type: none">• Screw an eyebolt into the labeled threaded hole (10).• By means of a crane, insert the vibration shaft (11) into the drum.• After inserting it, rotate the shaft to check whether the vibration shaft (11) is properly seated in the bearing case on the drum drive side.• Screw out the eyebolt (10).• Use 4 screws to install the coupling (7) in the bearing case (8) and to screw it onto the shaft.• Apply Loctite 518 to the sealing surface of the drum.• Insert the bearing case (8) into the vibration drive side, according to the following instructions: Inserting the bearing case (drum drive side):• Fill lubricating oil SAE 40 into the opening between the bearing retainer and the shaft.• for HR70C-9: 3.5 liters• for HR110/120/140C-9: 17 liters

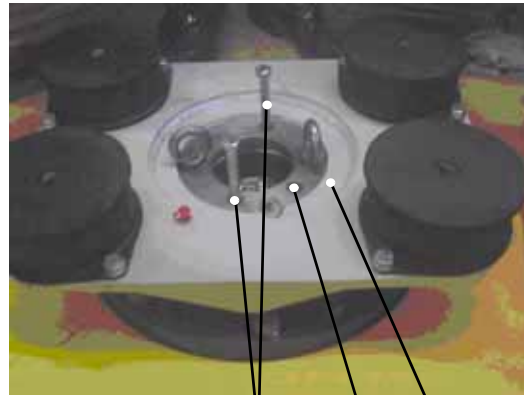
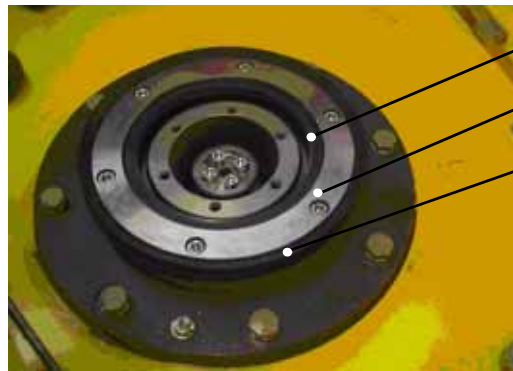
Figure**Work to be executed****Completing the vibration drive side**

- Slide new v-ring (30) with the sealing lip over the bearing cover (5) up to the stop.
- Slightly grease the sealing lip of the v-ring (30), the sealing face of the bearing cover (5) and the shaft sealing ring (23).
- Using a crane lift the side plate (3) from the eyebolts over the guide screws (1) onto the bearing cover (5).
- Turn the bolts (2) into the side plate (3) and tighten to the appropriate torque..
- To install the hydraulic components on the vibration drive side lift the drum on the vibration drive side with a crane, rotate it through 90° and put it down on the drum circumference.
- Press drive shaft (31) into the bearing housing up to the clutch.
- Using a depth gauge measure the dimension from the sealing face (32) to the clutch (7).
- Pull out shaft (31) up to the stop, and measure again, as described before, with the depth gauge.
- The balance of the two measurements is the bearing clearance.
- Compaction roller bearing clearances from 0.9 - 2.0 mm.
- Calibrate the clutch using the depth gauge.
- Bolt vibration motor 1 to the side plate with the connections pointing towards the grease nipple.

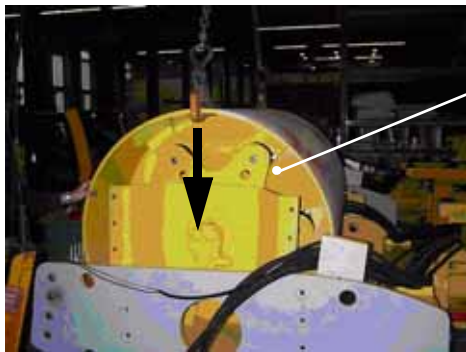
Figure**Work to be executed**

Completing the vibration drive side, continued:

- Slightly grease O ring (33) to seal the bearing housing/ vibration drive and push it onto the drive.
- Calibrate the clutch (34) on the vibration drive (2) using the depth gauge.
- Bolt vibration drive to the side plate with the connections pointing towards the grease nipple.

Drum (4) completely assembled and ready for installation in drum frame.

7.2.7 Installing the drum

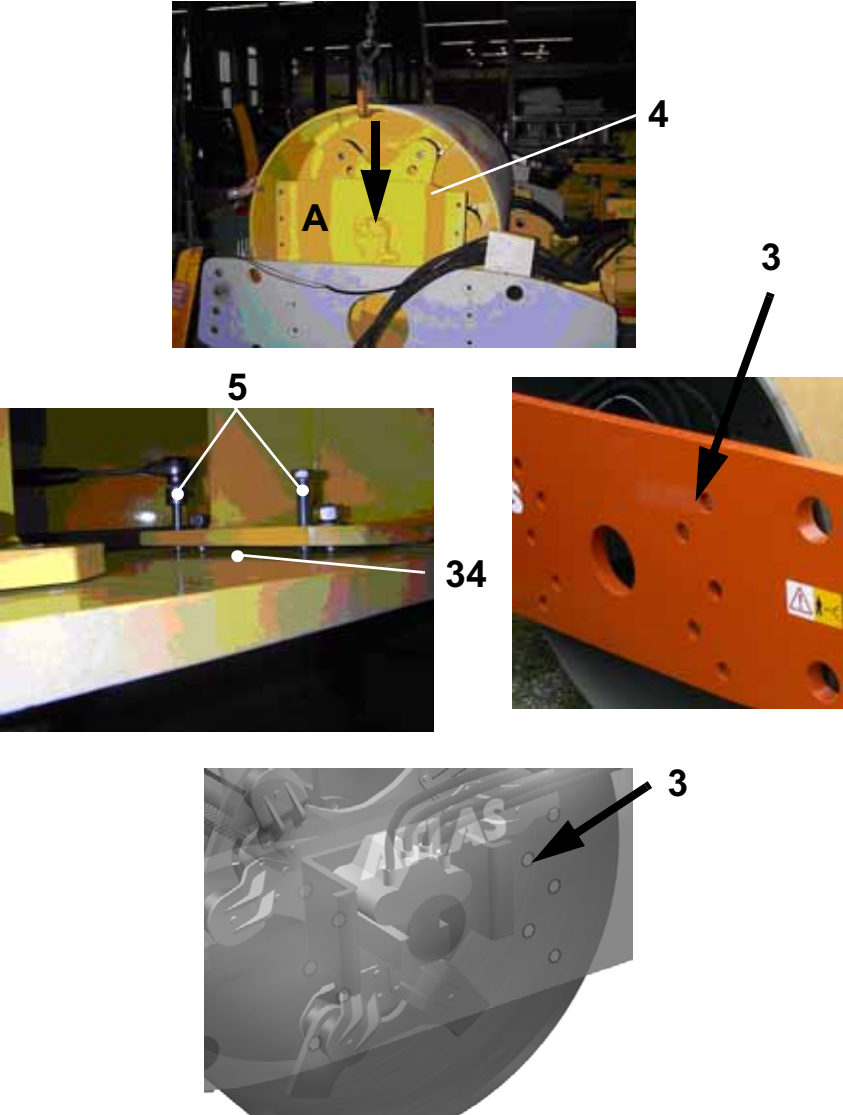
Figure	Work to be executed
 <p>The figure consists of three photographs illustrating the drum installation process. The top photograph shows the drum (4) being lowered into the drum frame. A black arrow points downwards towards the drum, and a white arrow points to the drum. A white letter 'A' is visible on the drum's interior. The middle-left photograph shows forcing screws (5) being used to pretension buffer brackets. A white arrow points to the screws, and a white letter '34' points to a shim. The middle-right photograph shows a close-up of the orange frame with a black arrow pointing to a bolt hole (3). The bottom photograph is a 3D CAD model of the drum assembly with a black arrow pointing to a bolt hole (3).</p>	<p>Reinsert the drum (4) into the drum frame after repair or replacement of components:</p> <ul style="list-style-type: none">• Ensure correct assignment of the drum drive side.• Using the crane lower the drum (4) so far that the screw holes match.• At first, turn in the bolts (3) on the drum drive side.• Pretension the buffer brackets on the vibration drive side about 1-2 mm using the forcing screws (5).• Insert shims (34) between frame and buffer bracket.• Slightly pretighten the bolts (3), then remove the clamping screws (5) and evenly tighten the fastening bolts (3).

Figure

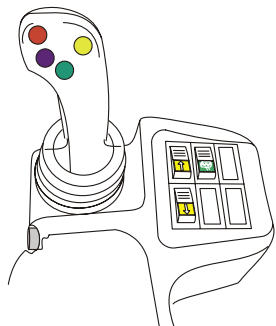
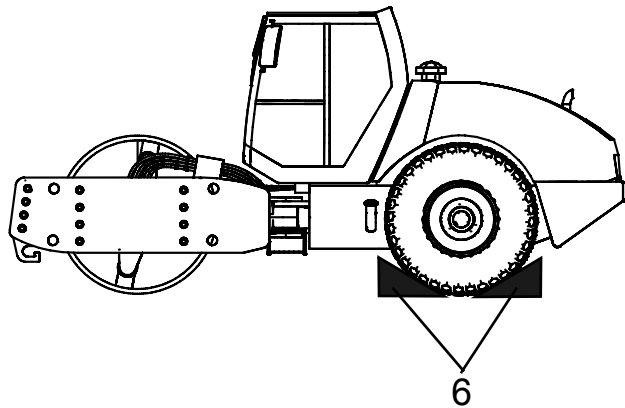
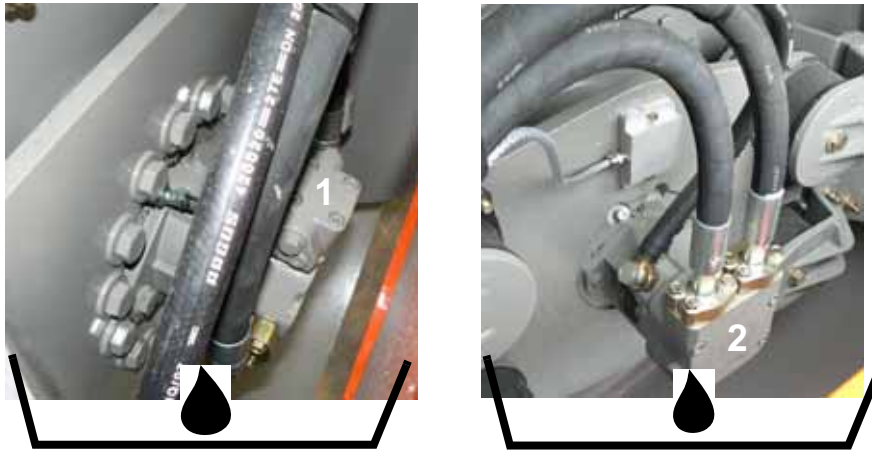

Work to be executed

Completing the hydraulic connections:

- Attach the hydraulic connections according to the marking on the drives.
 - Remove sealing plugs from hydraulic connections.
 - Attach the hydraulic connections to the drum drive (1) and the vibration drive (2).
 - Detach brake connection from gear motor.
-
- Wedge rear wheels (6).
 - Start Diesel engine, release parking brake and move drive lever slightly forwards and backwards to check whether the drum rotates correctly.
 - Fasten the drum frame to via lifting gear to a crane (2).
 - Lift the drum frame so far that the supports under the drum frame can be removed.
 - Perform the roller functions.



Chapter 8

Drive unit of the vibration system

Contents

This chapter provides you with information about:

- the vibration system and its drive unit
 - the functions and trouble shooting
 - the measuring and default values
 - the layout of the measuring points
 - the options for making adjustments
- 

8.1 Vibration system

8.1.1 Technical specifications

Type	HR70C-9	HR110C-9	HR120C-9	HR140C-9
Compaction capacity with smooth roller drum:				
Static linear load	22.40 kg/cm	29.00 kg/cm	32.80 kg/cm	38.00 kg/cm
Amplitude high / low	1.8 / 0.8 mm	1.8 / 0.8 mm	1.8 / 0.6 mm	1.9 / 0.7 mm
Frequency at high / low amplitude	30 / 40 Hz	30 / 38 Hz	30 / 40 Hz	30 / 40 Hz
Centrifugal force at high / low amplitude in kN	120 / 90	220 / 150	240 / 140	280 / 180
Compaction capacity with pad foot roller drum:				
Amplitude high / low	1.8 / 0.8 mm	1.8 / 0.6 mm	1.8 / 0.6 mm	1.9 / 0.7 mm
Frequency at high / low amplitude	30 / 40 Hz	30 / 38 Hz	30 / 40 Hz	30 / 40 Hz
Centrifugal force at high / low amplitude in kN	120 / 90	220 / 150	240 / 140	280 / 180

8.1.2 Overview: Vibration system

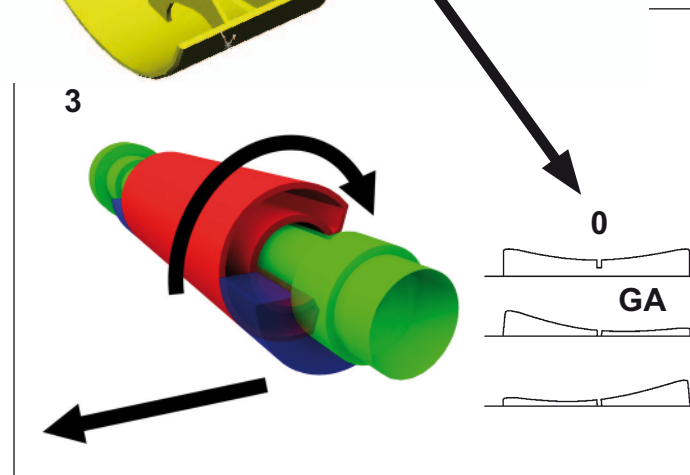
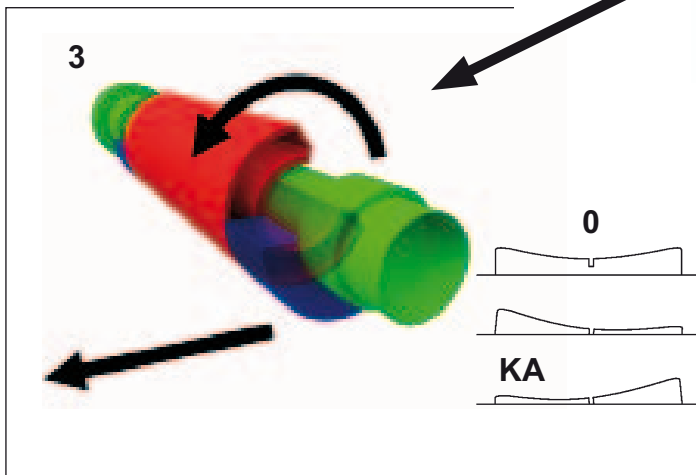
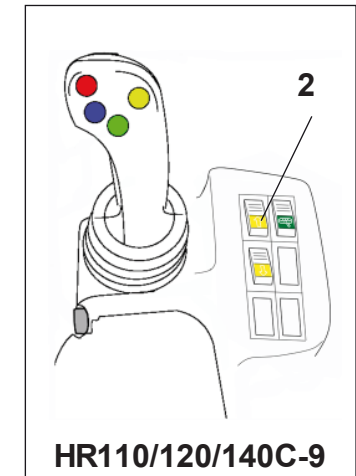
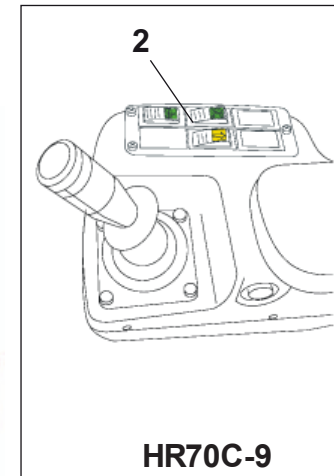
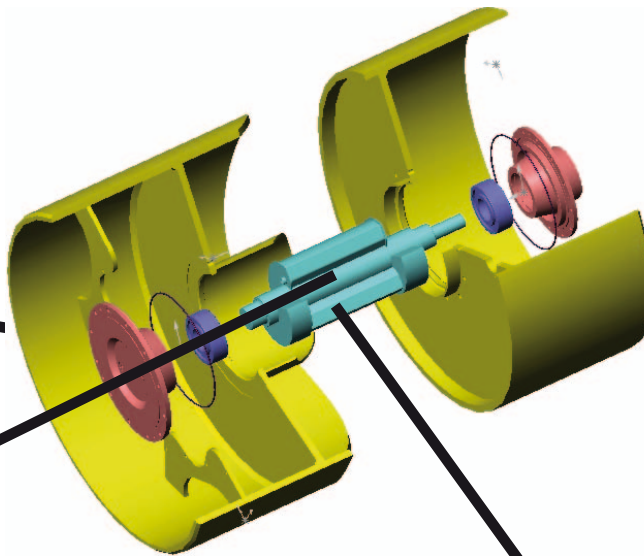

- 1 Drum
- 2 Vibration modes (Selector switch):
 - KA: low amplitude
 - GA: high amplitude
- 3 Vibration system
- 4 Vibration drive

8.1.3 Overview: Vibration Hydraulics

HR70C-9

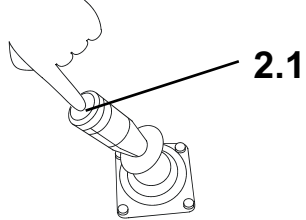
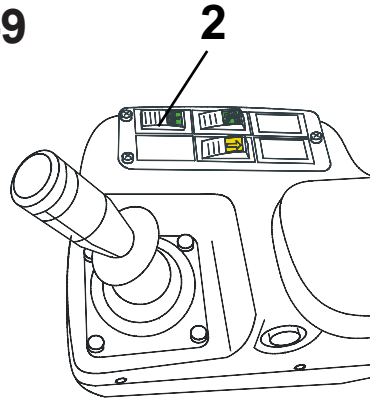

HR110/120/140C-9

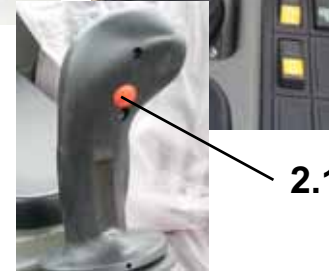

Vibration

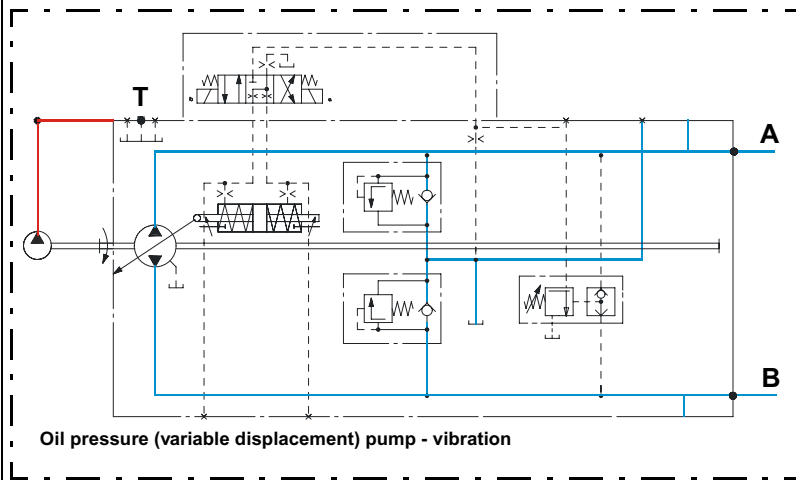
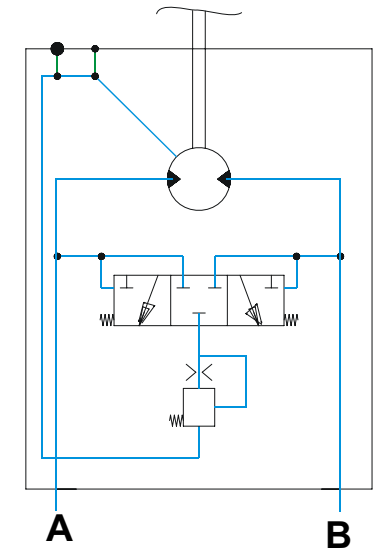

- = HP oil system A & B
- = Control oil system PS
- = Fuel line

- 1 Oil pressure pump - vibration
- 2 Joystick, vibration on (2.1)
- 3 Vibration mode selector switch
- 4 Vibration drive unit

8.1.4 Sequence of functions - Vibration mode

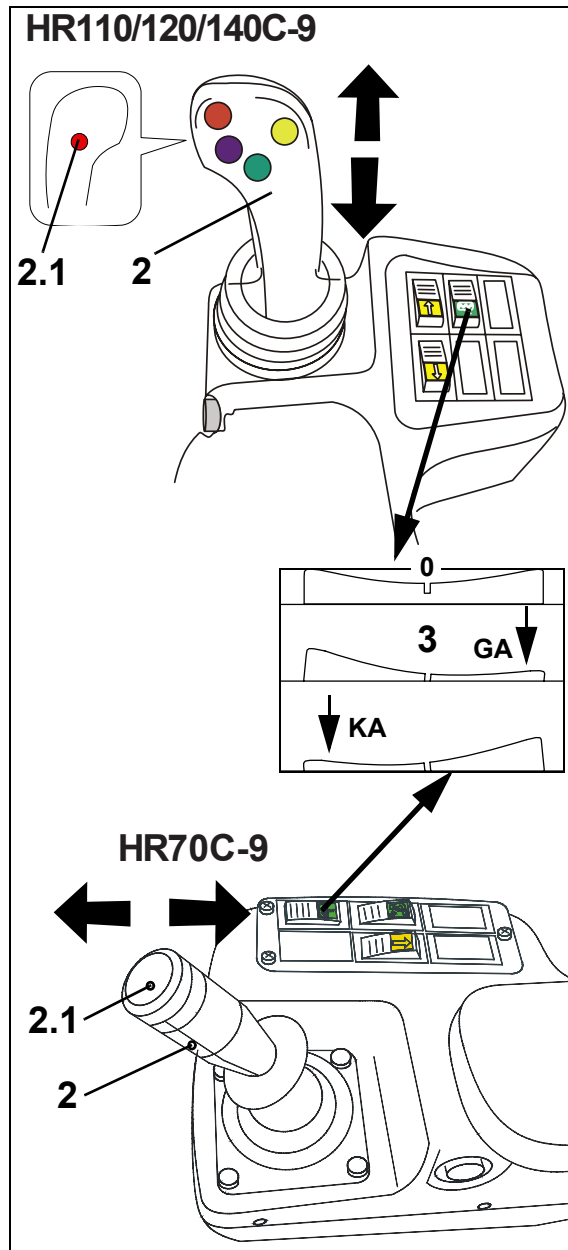

- After starting roller operation (i.e. the compaction roller moves forward or backwards), you can activate the vibration system as required.
- Set the selector switch (3) to the desired vibration mode.
 - Middle position **0**: no vibration mode selected
 - Switch set to position **KA** = (Y6) low amplitude.
 - Switch set to position **GA** = (Y6) high amplitude.
- In order to activate or deactivate vibration, press (2.1) on the joystick (see illustration on the left for types HR70C-9 or HR110/120/140C-9).
 - The corresponding solenoid valve (**KA** or **GA**) of the variable oil pressure pump of the vibration system) opens and releases the control oil pressure to the displacement disk of the pump.
 - The control pressure reaches the displacement disk of the variable oil pressure pump.
 - The pump swivels, depending on the selected vibration mode, and the oil flow reaches the vibration drive unit.

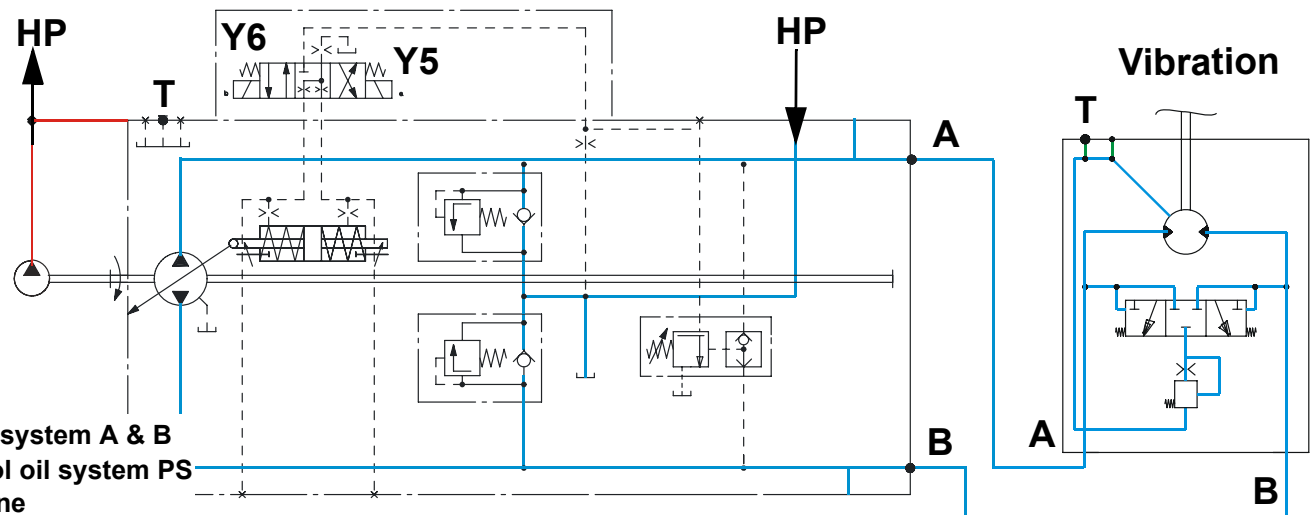

- = HP oil system A & B
- = Control oil system PS
- = Fuel line

8.1.5 Trouble shooting: What to do if the vibration does not start

Failure / Problem	Causes and actions to be taken	
Vibration cannot be activated	<ul style="list-style-type: none"> • Electrical fault • Insufficient charge pressure • Hydraulic fault 	<ul style="list-style-type: none"> • The vibration on/off button (2.1) on the joystick may be defective. • Check the functions of the vibration mode selector switch on the control panel. • Check Relay K04. • Check the charge pressure, make sure it is correct. • Check the high pressure A & B at the measuring points. • Check the coupling between the vibration motor and the shaft.
Vibration cannot be deactivated		<ul style="list-style-type: none"> • The vibration on/off button on the joystick is defective.
Rough-running, sluggish vibration	<ul style="list-style-type: none"> • Incorrect engine speed 	<ul style="list-style-type: none"> • Check the high pressure A & B at the measuring points MA & MB. • Check the oil level in the vibration bearing, see maintenance instructions.
Vibration generates a high noise level	<ul style="list-style-type: none"> • Incorrect frequencies 	<ul style="list-style-type: none"> • Check the vibration system.

8.2 Engine speeds, hydraulic measuring and default values

Measurement / Adjustment	Default values			Measuring point / method / tool
	HR70C-9	HR110/120C-9	HR140C-9	
Max. Diesel engine speed	2200 min ⁻¹	2200 min ⁻¹	2400 min ⁻¹	Diesel engine
At a high amplitude:				
Start-up pressure	280-300 bar	330-350 bar	330-350 bar	HR70C-9: MA HR110/120/140C-9: MB
Operating pressure	220-260 bar	230-280 bar	230-280 bar	
Frequency	30 Hz (corresponds to 1800 min ⁻¹ of the vibration shaft)	30 Hz (corresponds to 1800 min ⁻¹ of the vibration shaft)	30 Hz (corresponds to 1800 min ⁻¹ of the vibration shaft)	Sirometer / Adjusting screw V2
At a low amplitude:				
Start-up pressure	280-300 bar	330-350 bar	330-350 bar	HR70C-9: MB HR110/120/140C-9: MA
Operating pressure	150-190 bar	130-180 bar	130-180 bar	
Frequency	40 Hz (corresponds to 2400 min ⁻¹ of the vibration shaft)	HR110C-9 : 38 Hz / HR120C-9 : 40 Hz (corresponds to 2280 min ⁻¹ / 2400 min ⁻¹ of the vibration shaft)	HR140C-9 : 40 Hz (corresponds to 2280 min ⁻¹ / 2400 min ⁻¹ of the vibration shaft)	Sirometer / Adjusting screw V1
Amplitude at a high frequency	0.7 mm	HR110C-9 : 1.8 mm HR120C-9 : 0.6 mm	HR140C-9 : 0.7 mm	
Amplitude at a low frequency	1.6 mm	1.8 mm	HR140C-9 : 1.8 - 1.9 mm	
Run-up time vibration	2 to 3 seconds	2 to 4 seconds	2 to 4 seconds	Stop watch

8.2.1 Overview: Measuring points of the vibration hydraulics and required operating conditions

HR70C-9	HR110C-9/HR120C-9/HR140C-9
 <p>MB</p> <p>PS</p> <p>MA</p>	 <p>PS</p> <p>MB</p> <p>MA</p>



NOTE!

Vibration measurement:

A sirometer is required to establish the values regarding vibration, see **Using a sirometer**.



DANGER!

In order to measure the engine speeds and the hydraulic oil pressure, the Diesel engine needs to have reached its operating temperature and the hydraulic oil needs to have reached a minimum temperature of **50° C** in the feeding circuit.

8.2.2 Overview: Adjustments at the oil pressure pump (vibration)

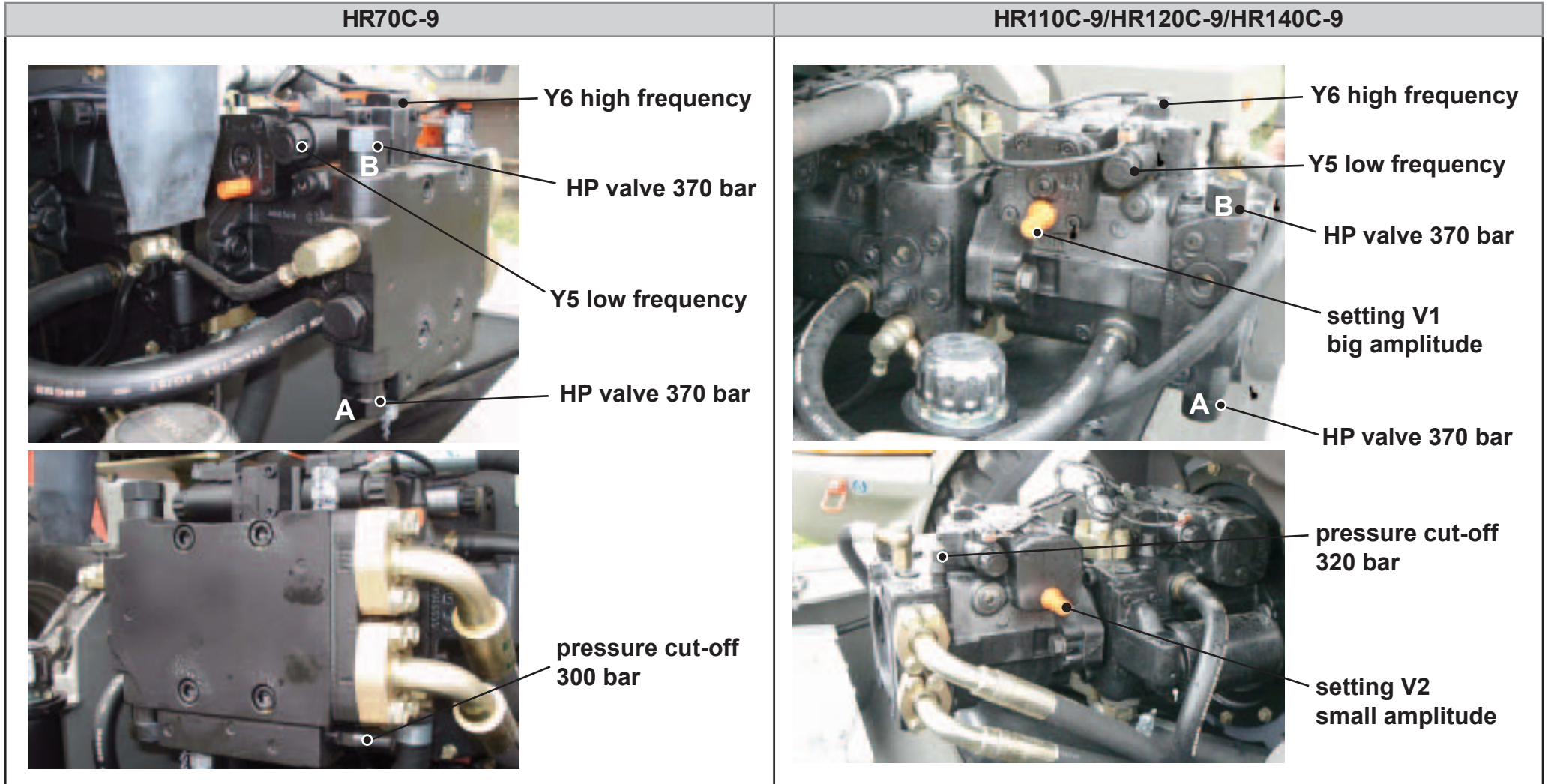

8.3 Using a sirometer

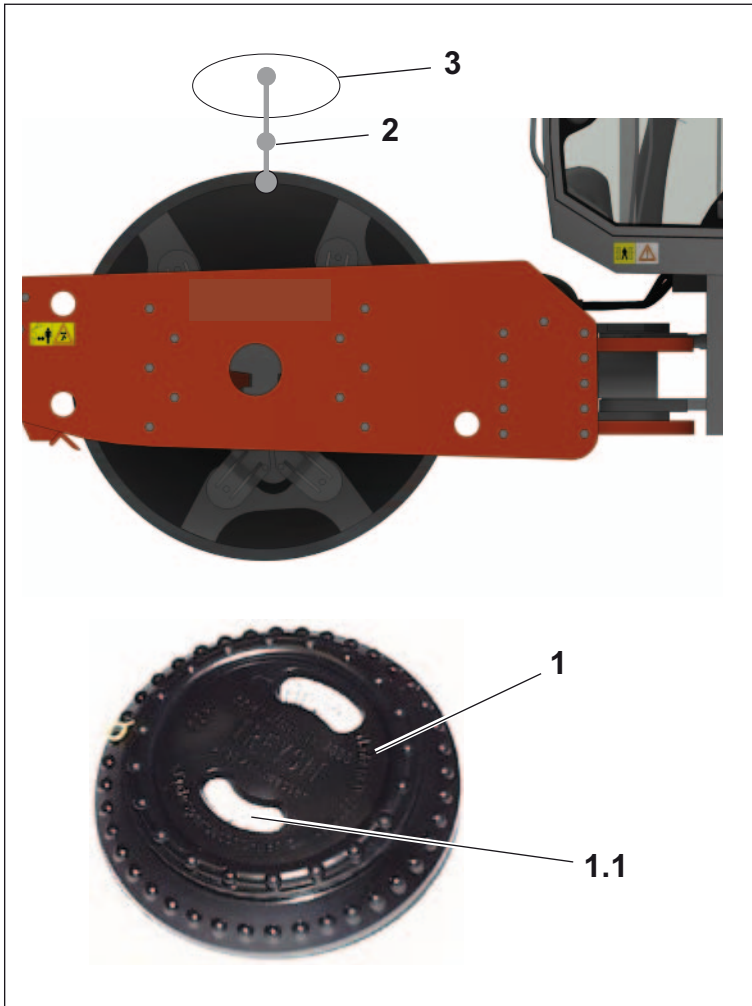

- A sirometer enables you to measure the engine speed and the frequency at any running engine or vibration unit with great accuracy.
- The TREYSIT sirometer (1) analyses the vibrancy at the drum.
- The engine speed or frequency (lower scale, 1.1) to be measured is displayed on both scales.
- The TREYSIT sirometer has been tested and approved by the "Physikalisch-Technische Bundesanstalt" (national metrology institute providing scientific and technical services) in Braunschweig. With a tolerance of 1-2%, its accuracy is appropriate for the measurements in question.



DANGER!

Risk of injuries!

The vibration measurement by means of a sirometer may only be carried out with the roller **stopped!**

- In order to conduct the measurement, position the sirometer (1) on the edge of the drum.
- Turn the top part of the sirometer to the left so the measuring wire (2) is extended.
- With the vibration activated, the end of the measuring wire (2) starts to deflect (3).
- After recording the furthest deflection (3) of the measuring wire (2), the amount of vibrations per second (in Hz) is displayed on the lower scale (1.1).



Chapter 9

Electrical system

Contents

This chapter provides you with information about:

- the electrical system
 - maintenance work related to the electrical system
 - fuses, relays and positions of the components
 - the electric circuit diagrams
- 

9.1 Electrical system



ATTENTION!

The HYUNDAI compaction rollers dispose of an operating voltage of **12 Volt**. Be sure to take this into account when jump-starting the vehicle or replacing components.



WARNING!

Any repair work related to the electrical system may be carried out by trained professional service staff only!



WARNING!

Prior to performing any work referring to electrical components of the wiring, disconnect the plus terminal (2) from the battery (1).





9.1.1 Maintenance work referring to the electrical system



DANGER!

Risk of explosions!

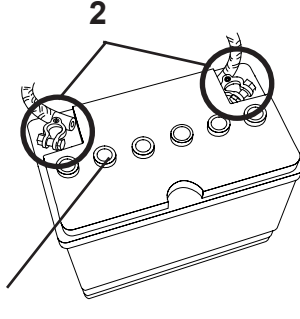
Whenever maintenance work related to the electrical system is carried out, keep away sparks and open fire from the battery. **Do not smoke!**

Illustration	Battery
Maintenance work to be carried out on a monthly basis:	
<div style="display: flex; justify-content: space-around;"> <div style="text-align: center;">  <p>HR70C-9</p> </div> <div style="text-align: center;">  <p>HR110/120/140C-9</p> </div> <div style="text-align: center;">  </div> </div>	<ul style="list-style-type: none"> • Check the battery terminals (2) for signs of corrosion and dirt. • Lubricate the poles and terminals. Required grease: order no. 0830684. • Open the cover caps (3) of the battery and check the fill level above the cells. • Make sure the fill level is sufficient, i.e. above the cells. <div style="background-color: #ffffcc; padding: 5px; margin-top: 10px;">  <p>CAUTION! Add distilled water only!</p> </div>

9.1.2 Overview: Electrical system HR70C-9

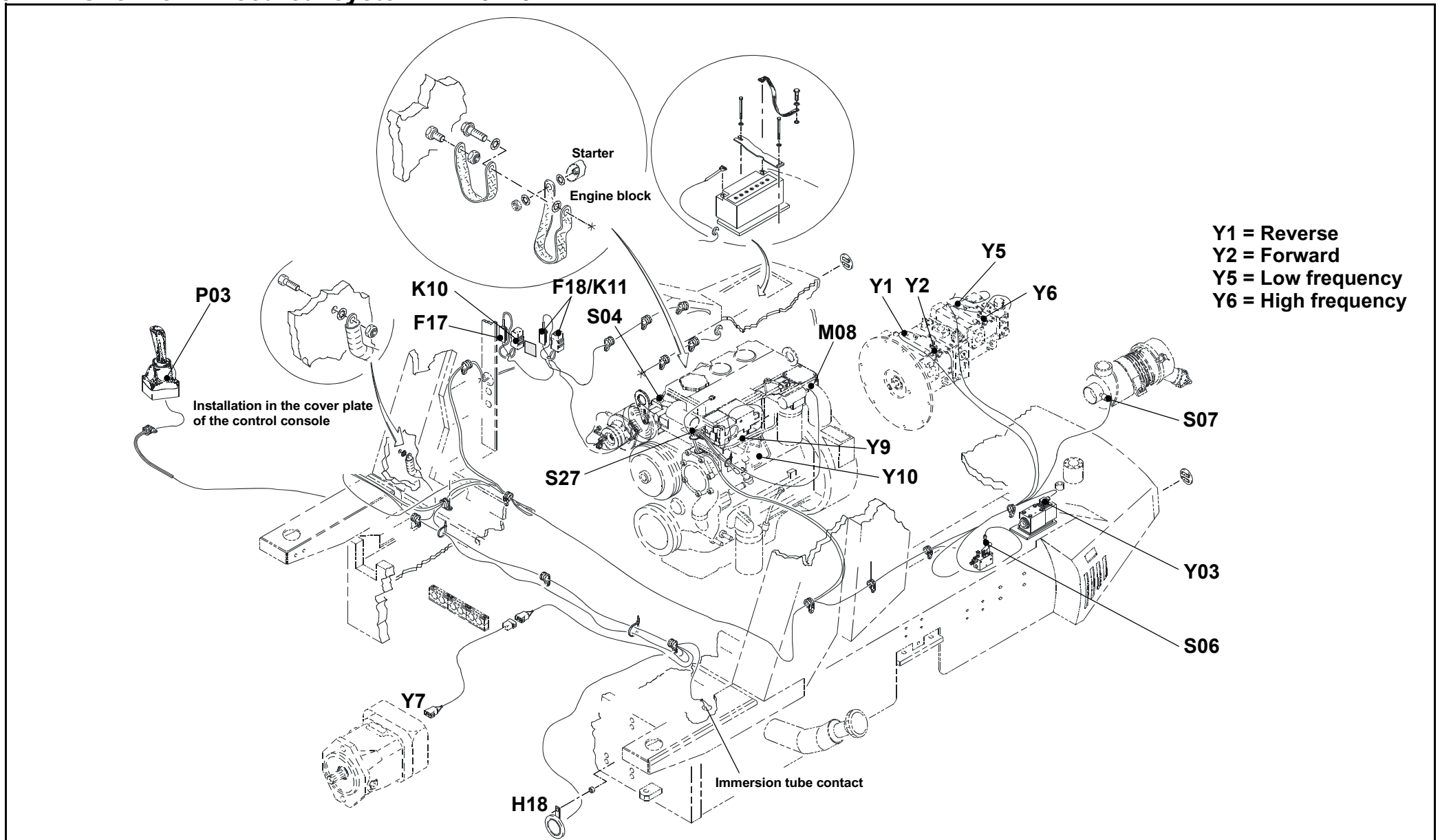

9.1.3 Overview: Electrical system HR110/120/140C-9

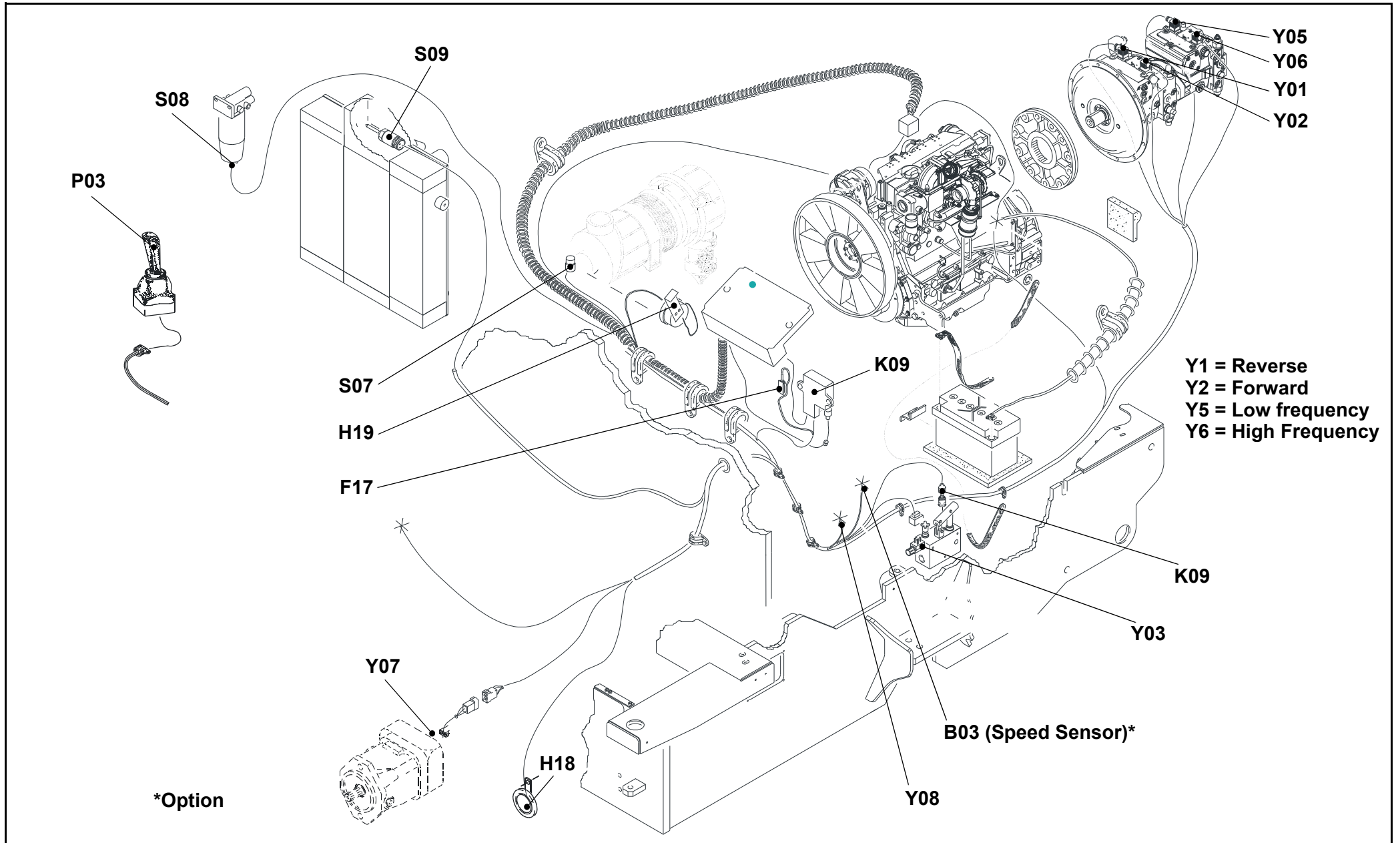

9.1.4 Printed circuit board, fuses and relays

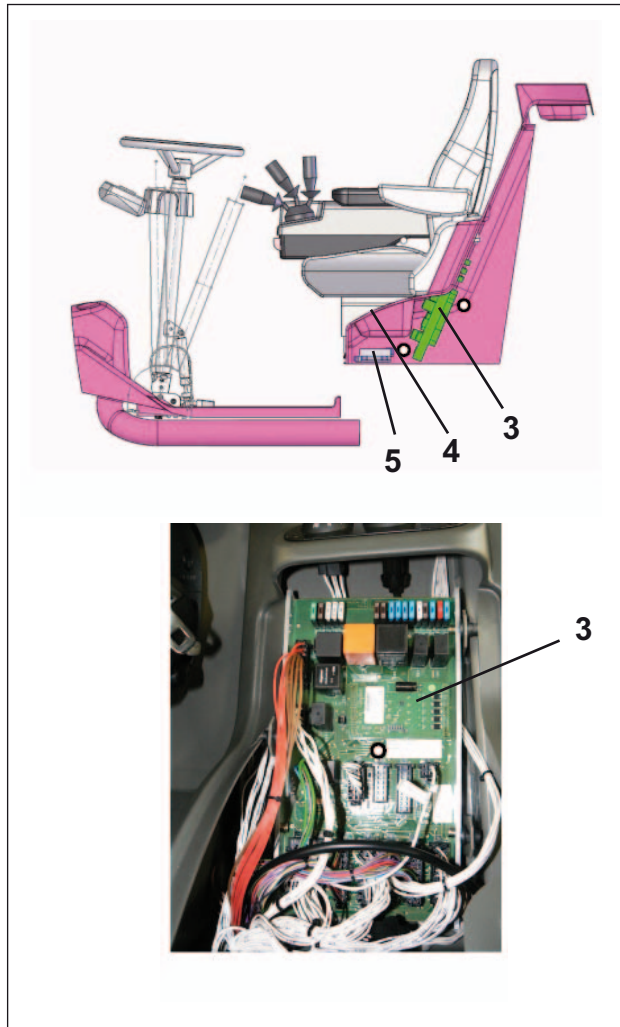

Printed circuit board

- The printed circuit board (3) constitutes the control center of the electrical system. This is where the fuses and relays of the compaction roller are installed.
- The printed circuit board is to be found under a cover plate (4), next to the driver's seat (left side).
- Open the plate (4) covering the printed circuit board (3) and check its condition by a visual inspection.
- Check all the fuses and relays for damage and dirt.
- Always replace defective fuses, see Allocation of the fuses on the printed circuit board.
- The Rexroth control box (5) for the joystick (reverse/forward motion) is also installed below the cover (4).

Allocation of the fuses on the printed circuit board

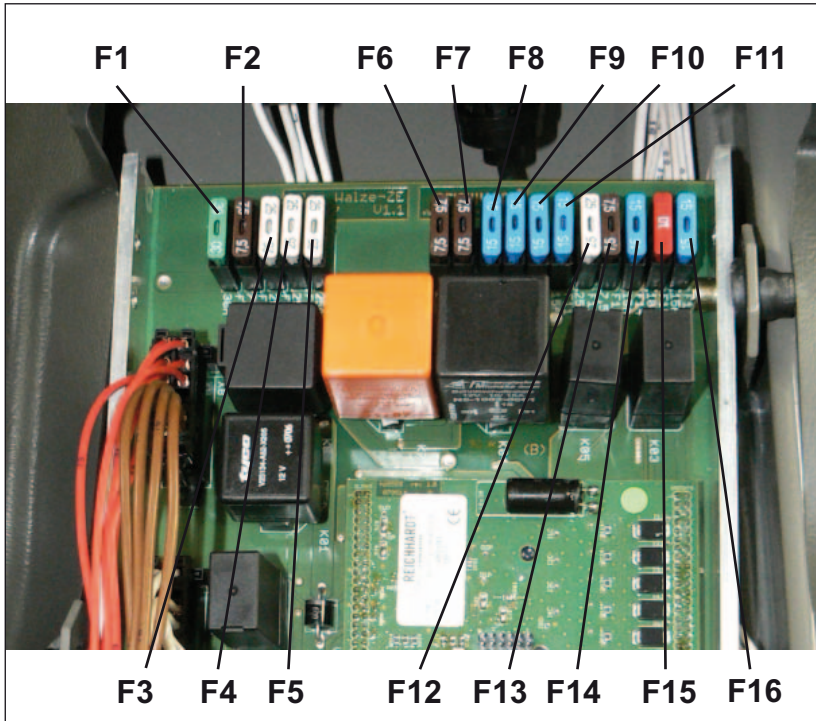

No.	Ampere	Function	No.	Ampere	Function
F1	30 A	Ignition lock, starter, preheating	F10	15 A	Rotating light, front work lights
F2	7.5 A	Radio	F11	15 A	Rear work lights
F3	25 A	Relay K08, EMR 3	F12	25 A	Fan (heating unit), air conditioning (optional feature)
F4	25 A	Time relay rear window heating	F13	7.5 A	Control climate coupling
F5	25 A	Air conditioning (optional feature), heat exchanger	F14	15 A	Socket, rotating sensor
F6	7.5 A	Control lights, fuel gauge, Generator D+	F15	10 A	Emergency off, relay K3, brake, air filter, RC2-2, H03
F7	7.5 A	Gearshift drum, axle	F16	15 A	DRCA-RC2-2, Vibration, joystick, ECO, engine speed control, backup warner, Diesel valve, Diesel pump
F8	15 A	Horn, electrical seat features (optional), rear window control	F17	80 A	Preheating
F9	15 A	Front and rear wipers			

Fuses and relays in the engine compartment

HR70C-9

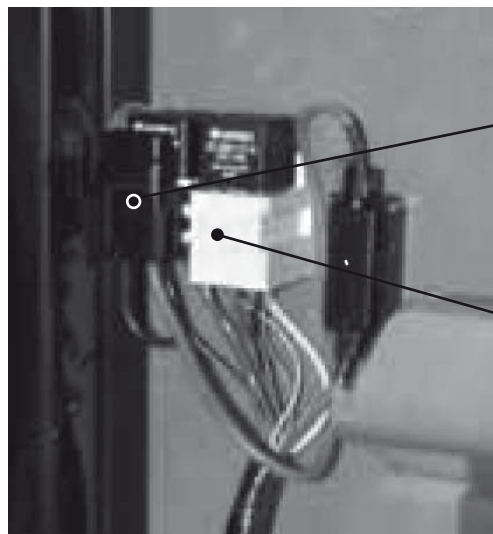

- Check the fuses (**F17**) and the relay (**K10**, preheating relay) in the engine compartment for damage and dirt.
- Always replace defective fuses.

HR110C-9/HR120C-9/HR140C-9

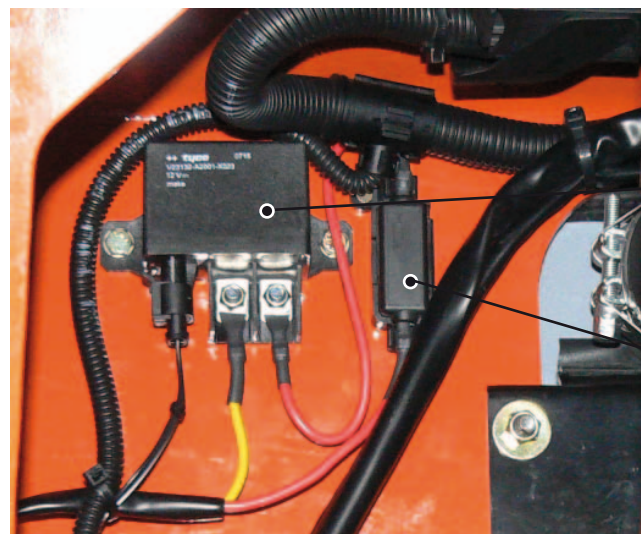

- Check the fuses (**F17**) and the relay (**K10**, preheating relay) in the engine compartment for damage and dirt.
- Always replace defective fuses.

Functions of the relays

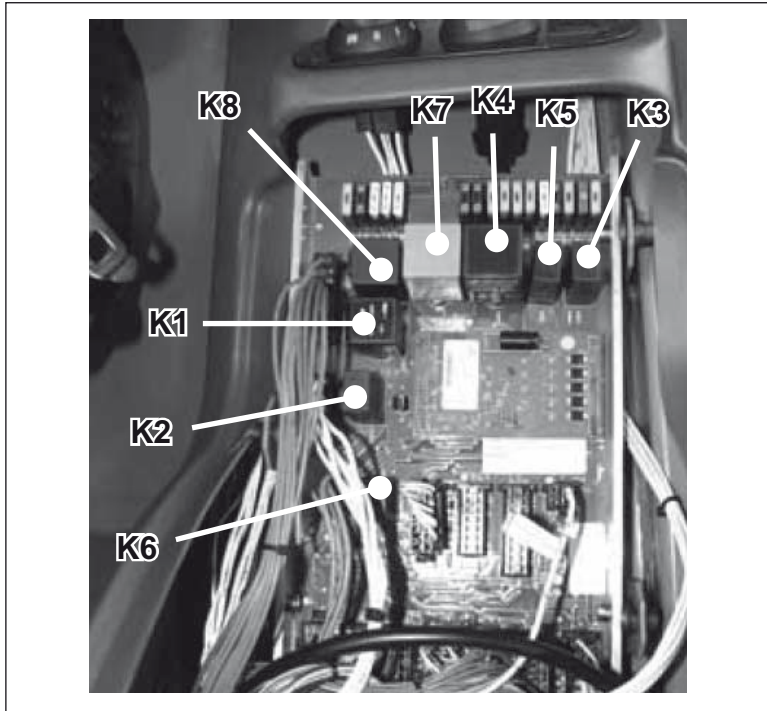

No.	Function	Location	Plan No.
K01	Ignition lock	Printed circuit board	1
K02	Starter, Ignition lock	Printed circuit board	1
K03	Parking brake, Emergency-off push-button	Printed circuit board	1
K04	Vibration	Printed circuit board	4
K05	Vibration	Printed circuit board	4
K06	Selector switch vibration mode	Printed circuit board	4
K07	Diesel engine control	Engine compartment	7
K08	Rear window heating	Printed circuit board	10
K09	Preheating relay	Engine compartment	2

Overview: Switches (see electric circuit for functions)

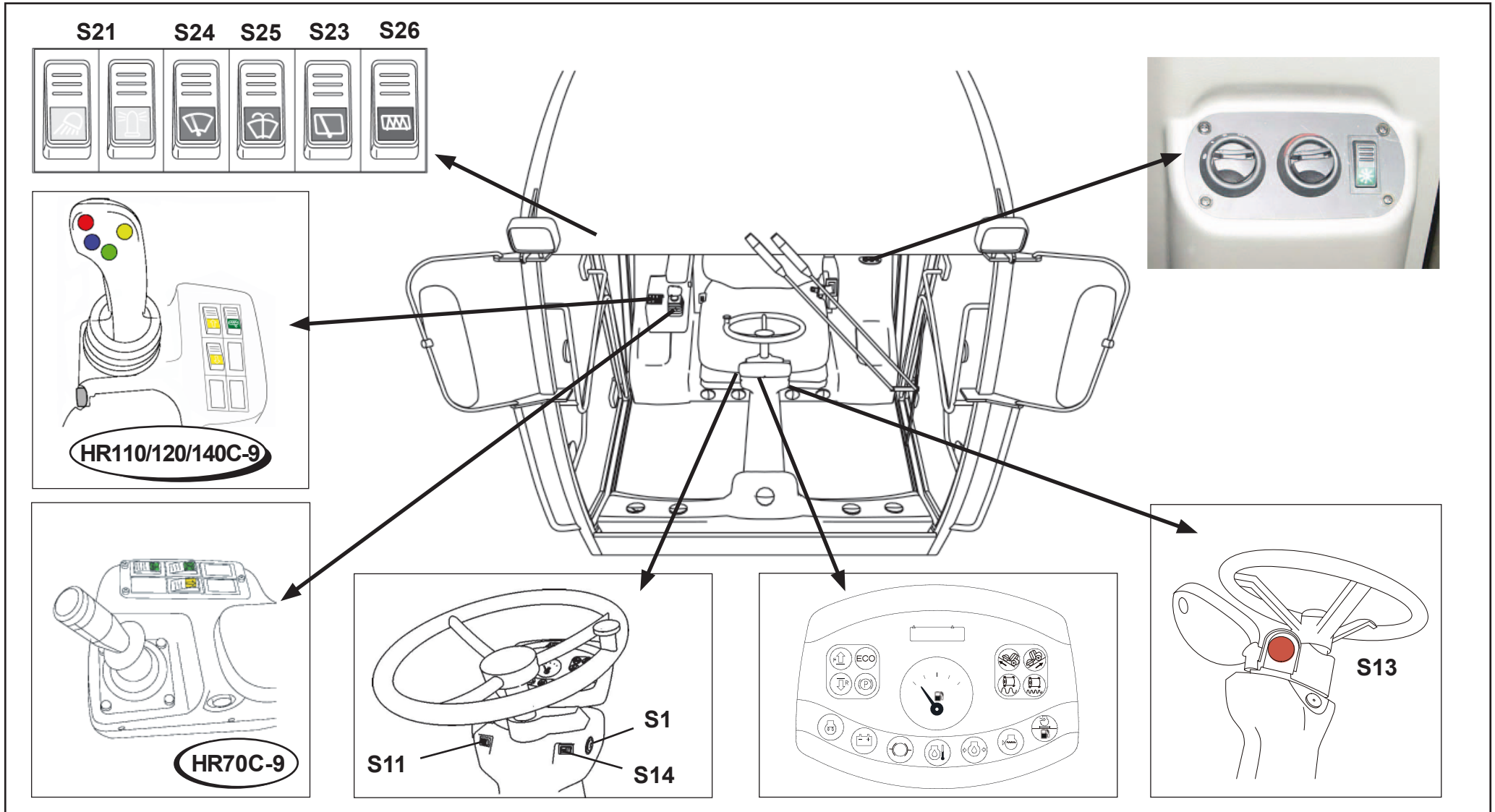



Electric circuit diagrams

HR70C-9



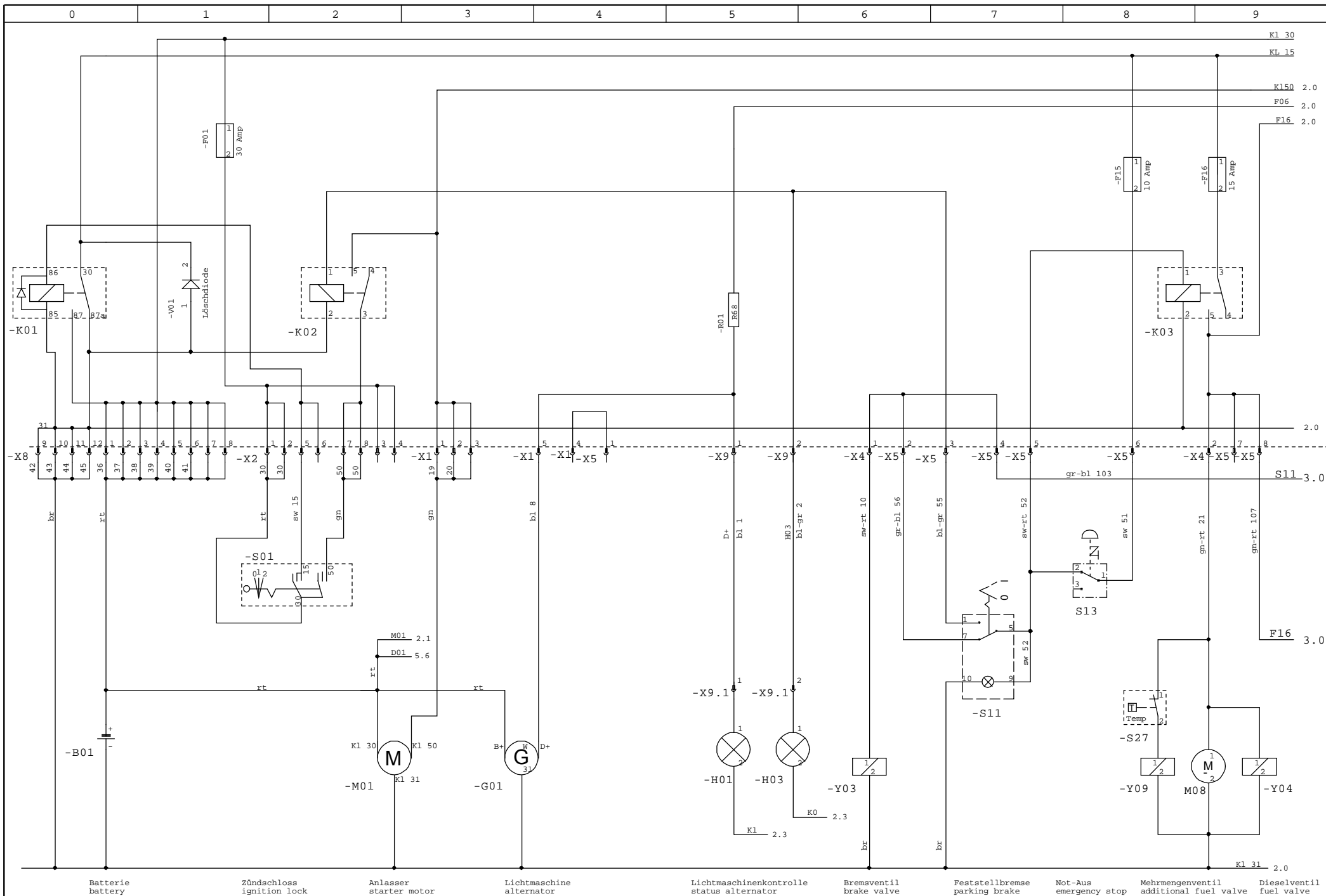

001	07.05.07	Heuer	Datum	07.05.2007							
002	01.11.07	Heuer	Bearb.	W.Heuer							
Zust.	Änderung	Datum	Name	Norm	Urspr.	Ers.f	Ers.d				

Vers 02

Atlas Weyhausen AG & CO KG
 Maschinenfabrik
 27793 Wildeshausen

AW-2501 /1070

Stromlaufplan PFE 2501

Blatt 1
 von 14 Bl.

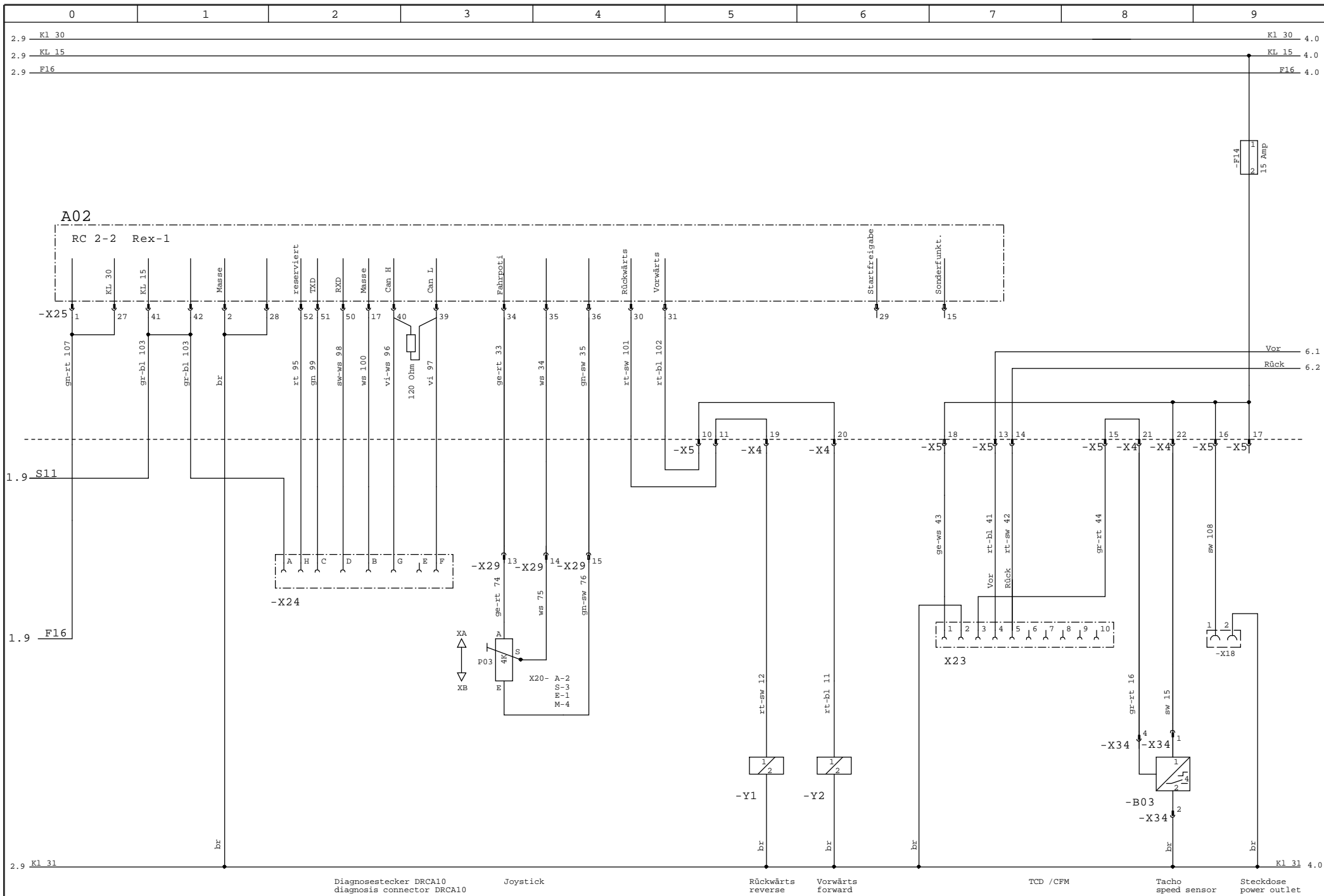

001	07.05.07	Heuer	Datum	07.05.2007		Atlas Weyhausen AG & CO KG Maschinenfabrik 27793 Wildeshausen	AW-2501 /1070	Stromlaufplan PFE 2501	Blatt 3 von 14 Bl.
002	01.11.07	Heuer	Bearb.	W.Heuer					
Zust.	Änderung	Datum	Name	Norm	Urspr.	Ers.f	Ers.d		

Vers 02

Stromlaufplan PFE 2501

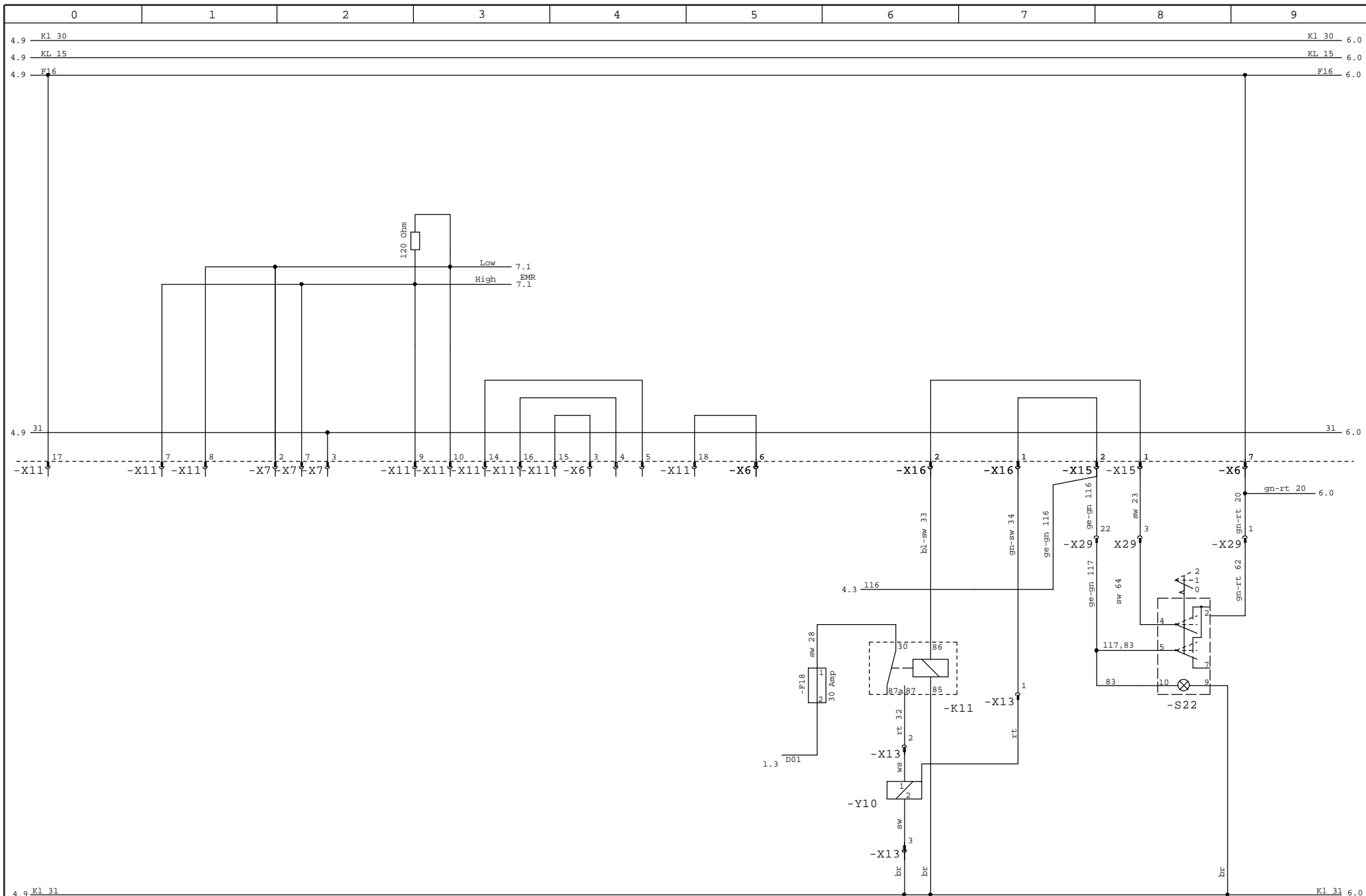

4.9 Kl 31 6.0
 4.9 Kl 31 6.0
 4.9 Kl 31 6.0

001	07.05.07	Heuer	Datum	07.05.2007								
002	01.11.07	Heuer	Bearb.	W.Heuer								
Zust.	Änderung	Datum	Name	Norm	Urspr.	Ers.f	Ers.d					

Vers 02

Atlas Weyhausen AG & CO KG
 Maschinenfabrik
 27793 Wildeshausen

AW-2501 /1070

Stromlaufplan PFE 2501

Blatt 5
 von 14 Bl.

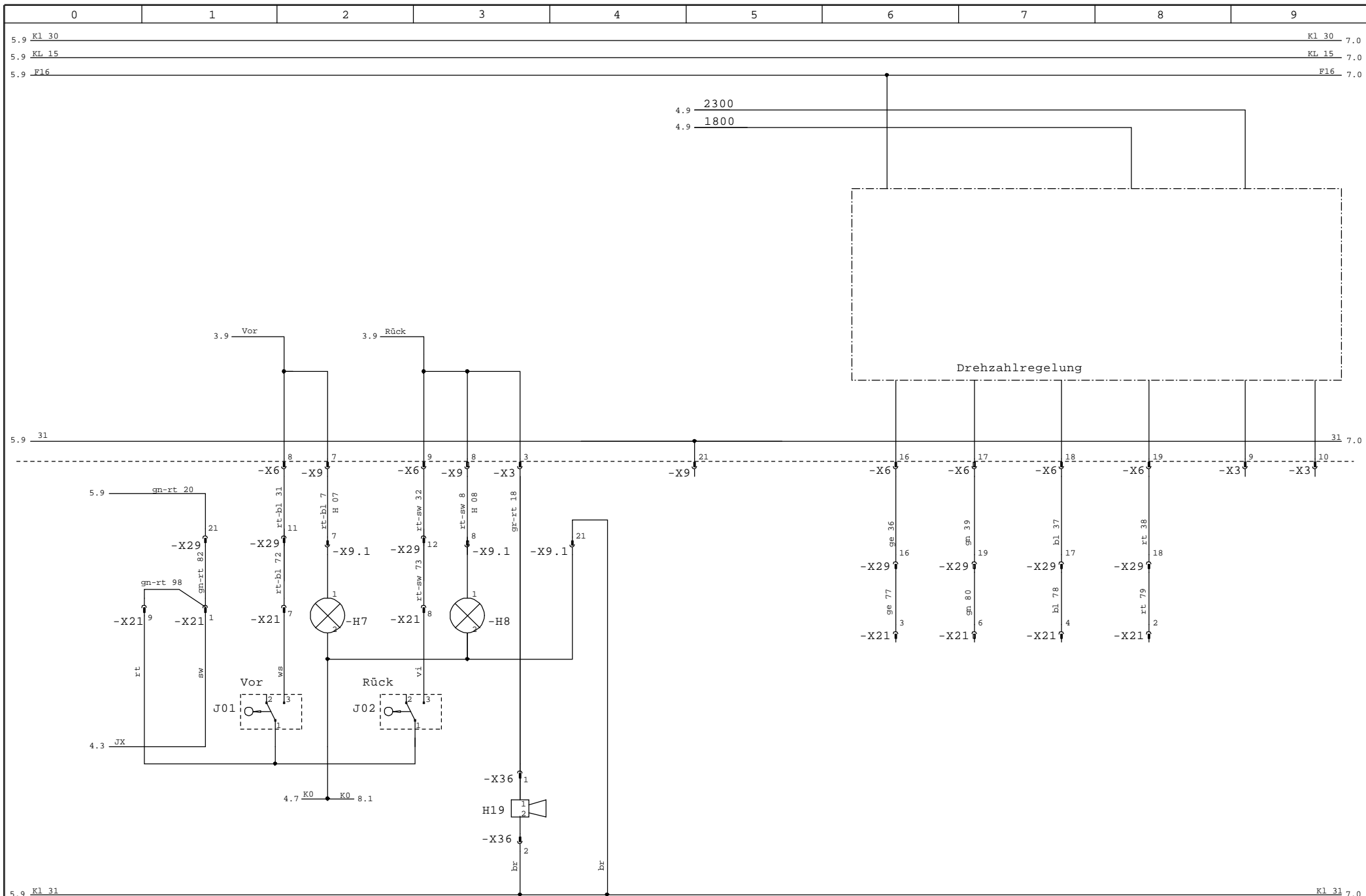

5.9 Kl 31 Kl 31 7.0

vorwärts forward rückwärts reverse Rückfahrsummer backup alarm

001	07.05.07	Heuer	Datum	07.05.2007		Vers 02	Atlas Weyhausen AG & CO KG Maschinenfabrik 27793 Wildeshausen	AW-2501 /1070
002	01.11.07	Heuer	Bearb.	W.Heuer				
			Gepr.					
Zust.	Änderung	Datum	Name	Norm	Urspr.	Ers.f	Ers.d	Stromlaufplan PFE 2501
								Blatt 6 von 14 Bl.

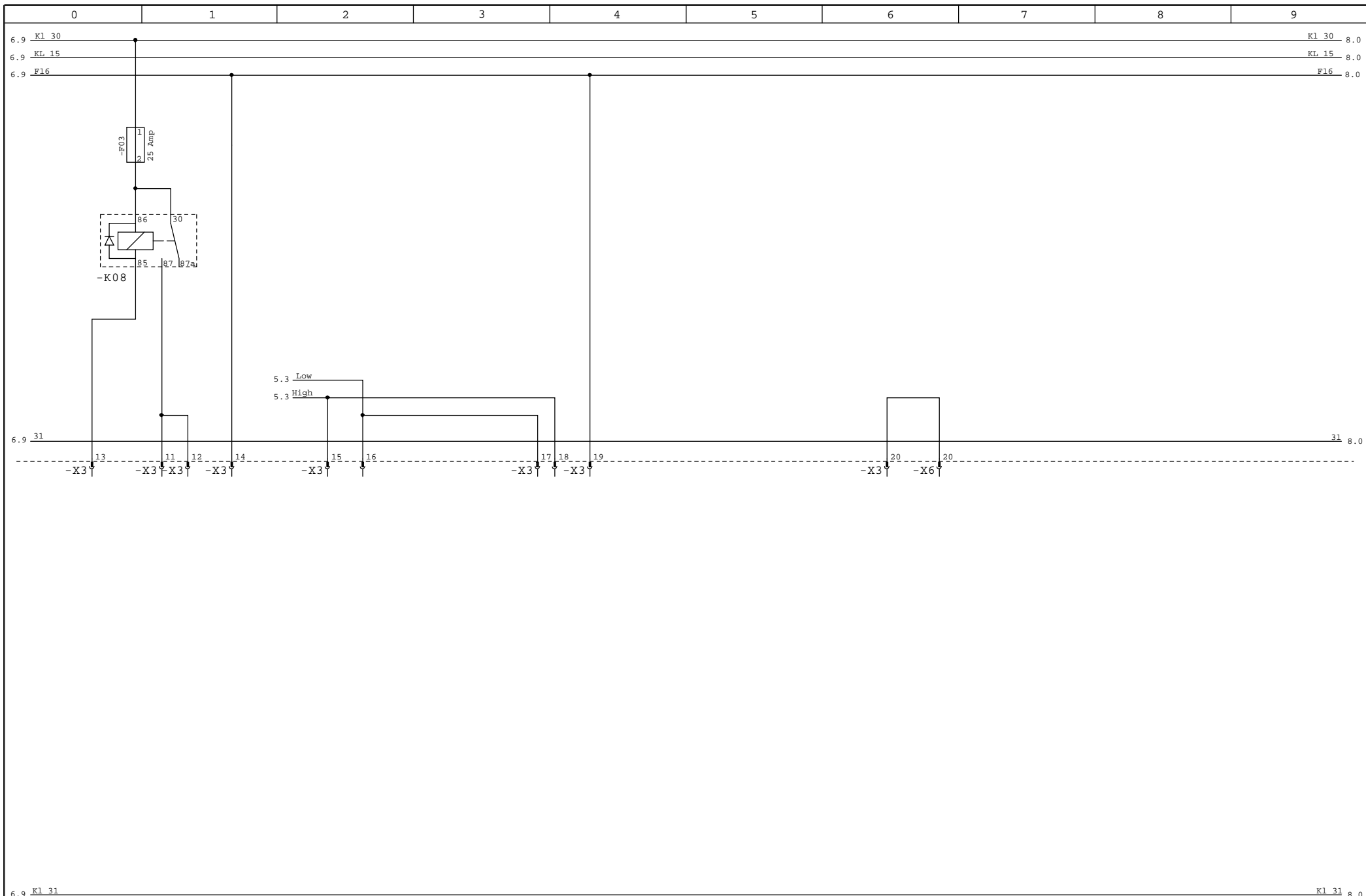

001		07.05.07	Heuer	Datum	07.05.2007			Atlas Weyhausen AG & CO KG	AW-2501 /1070	
002		01.11.07	Heuer	Bearb.	W.Heuer			Maschinenfabrik		
				Gepr.				27793 Wildeshausen		
Zust.	Änderung	Datum	Name	Norm	Urspr.	Ers.f	Ers.d		Stromlaufplan PFE 2501	Blatt 7 von 14 Bl.

Vers 02

Stromlaufplan PFE 2501

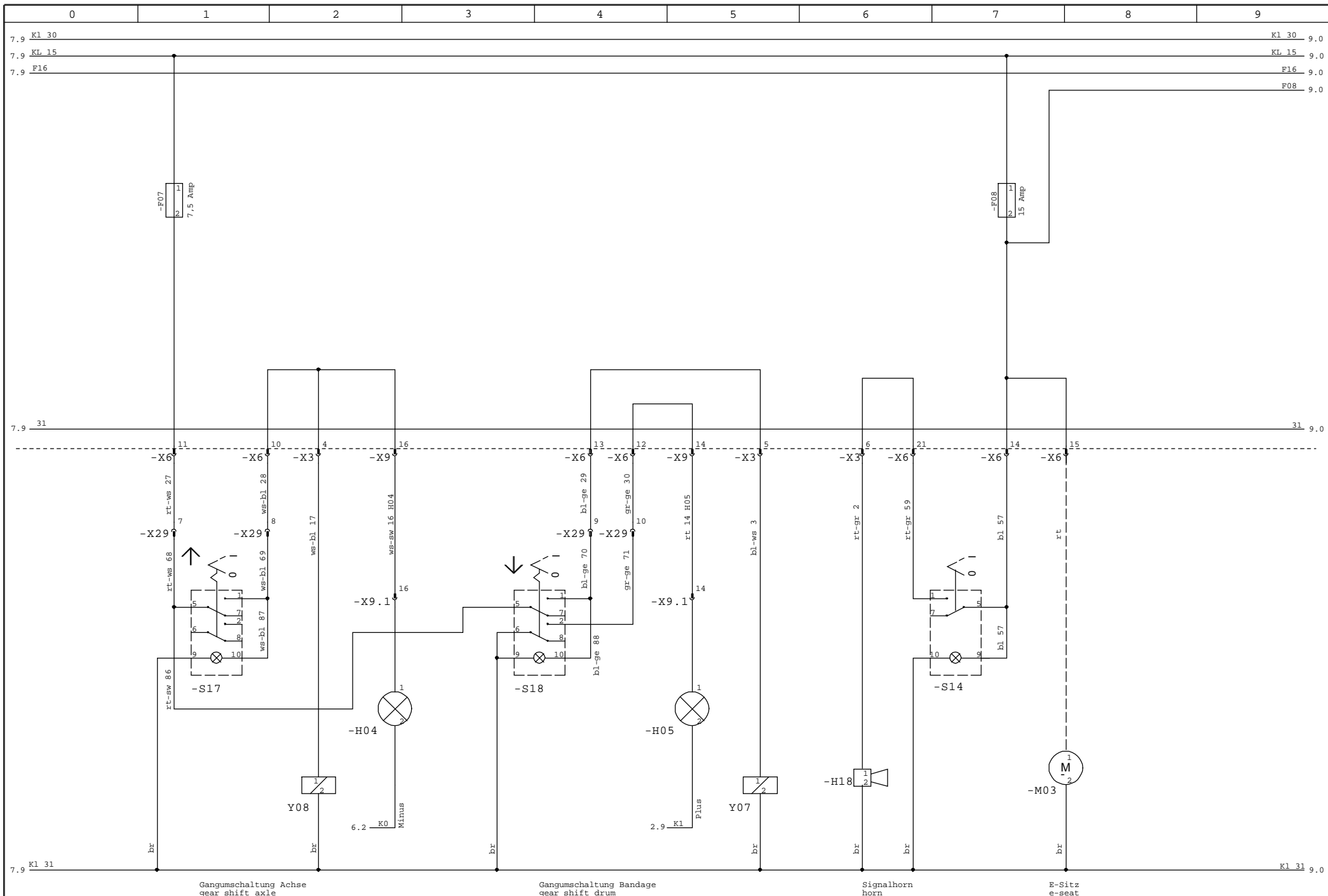

001	07.05.07	Heuer	Datum	07.05.2007
002	01.11.07	Heuer	Bearb.	W.Heuer
			Gepr.	
Zust.	Änderung	Datum	Name	Norm
			Urspr.	Ers.f
				Ers.d

Vers 02

Atlas Weyhausen AG & CO KG
 Maschinenfabrik
 27793 Wildeshausen

AW-2501 / 1070

Stromlaufplan PFE 2501

Blatt 8
 von 14 Bl.

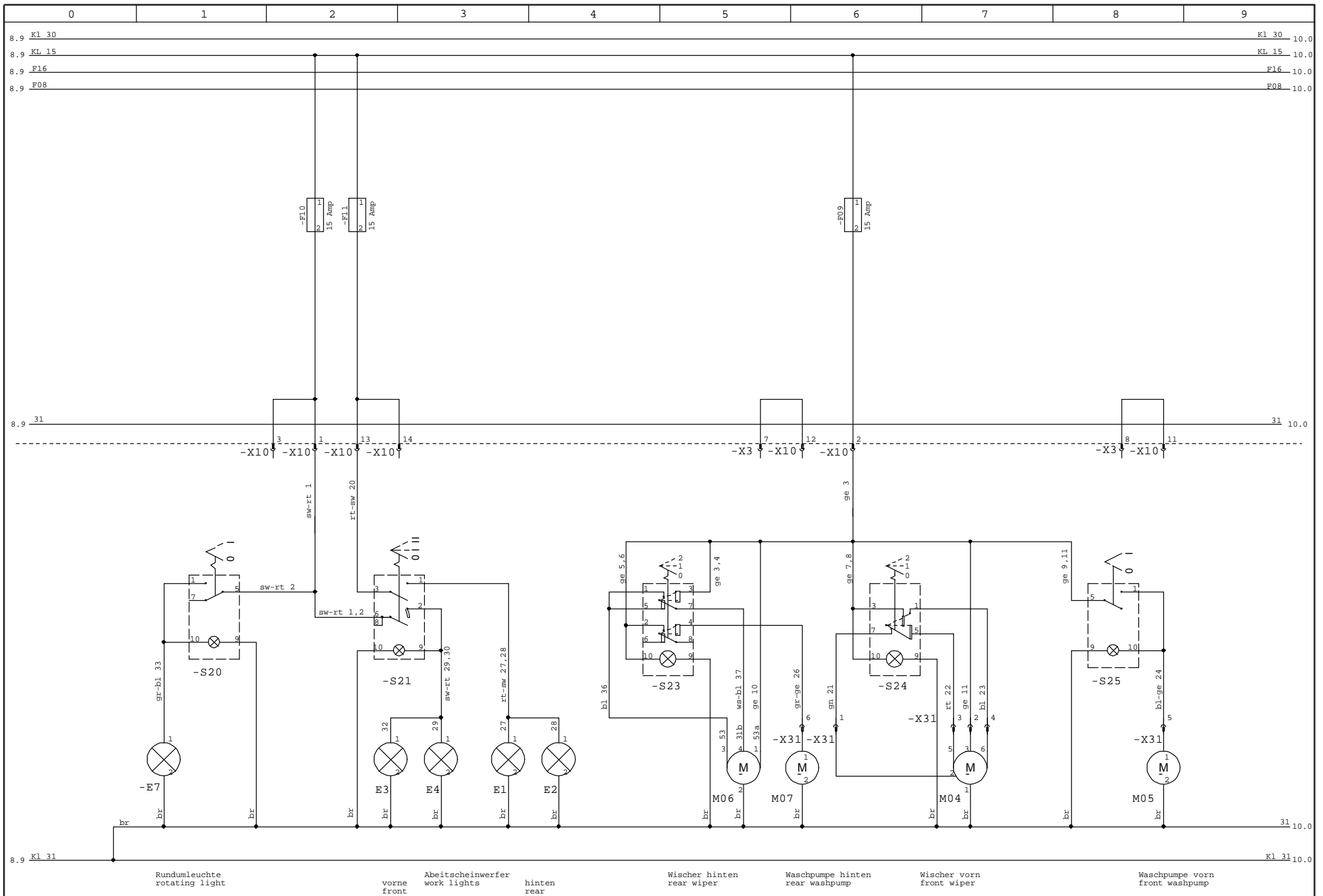

001	07.05.07	Heuer	Datum	07.05.2007							
002	01.11.07	Heuer	Bearb.	W.Heuer							
Zust.	Änderung	Datum	Name	Norm	Urspr.	Ers.f	Ers.d				

Vers 02

Atlas Weyhausen AG & CO KG
 Maschinenfabrik
 27793 Wildeshausen

AW-2501 /1070

Stromlaufplan PFE 2501

Blatt 9
 von 14 Bl.

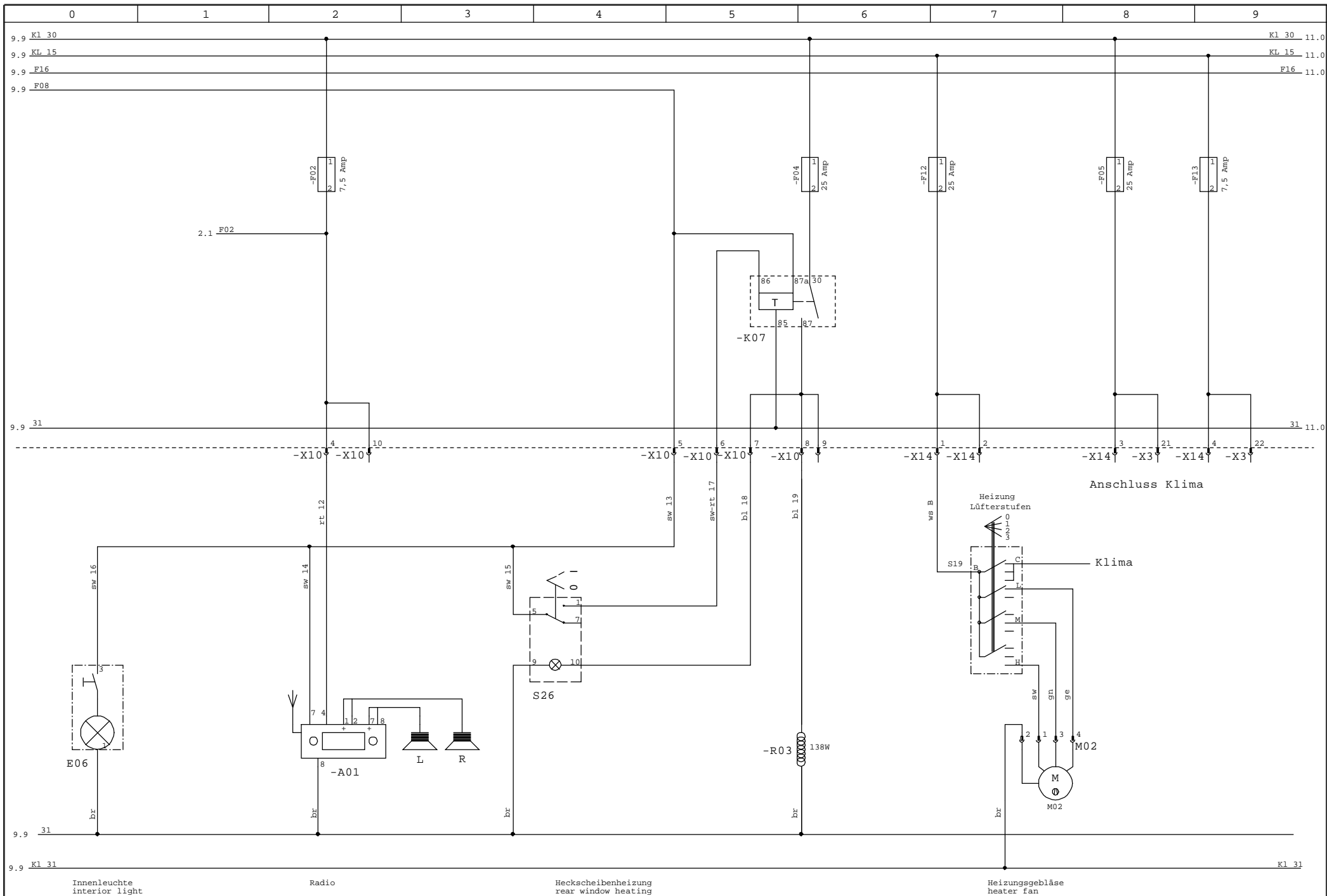

001	07.05.07	Heuer	Datum	07.05.2007
002	01.11.07	Heuer	Bearb.	W.Heuer
			Gepr.	
Zust.	Änderung	Datum	Name	Norm
			Urspr.	Ers.f
				Ers.d

Vers 02

Atlas Weyhausen AG & CO KG
 Maschinenfabrik
 27793 Wildeshausen

AW-2501 / 1070

Stromlaufplan PFE 2501

Blatt 10
 von 14 Bl.

weiss	ws	white	wh
grau	gr	grey	gy
gelb	ge	yellow	ye
rosa	rs	pink	pk
rot	rt	red	rd
grün	gn	green	gn
blau	bl	blue	bl
braun	br	brown	bn
orange	or	orange	og
violett	vi	violet	vt
schwarz	sw	black	bk
türkis	tk	turquoise	tq



Electric circuit diagrams

HR110C-9, HR120C-9, HR140C-9



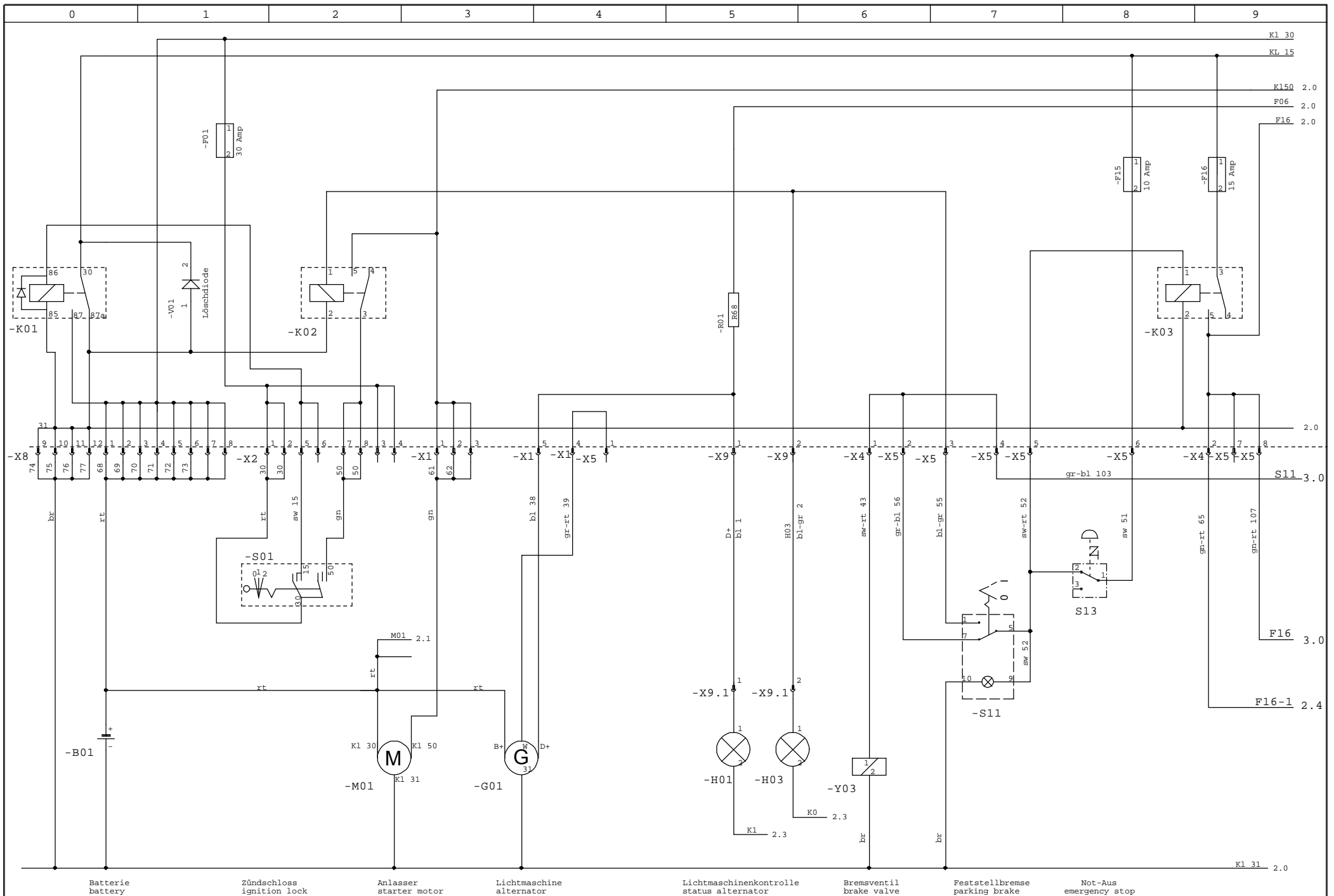

001	07.05.07	Heuer	Datum	07.05.2007								
002	01.11.07	Heuer	Bearb.	W.Heuer								
			Gepr.									
Zust.	Änderung	Datum	Name	Norm	Urspr.	Ers.f	Ers.d					

Vers 02

F.Weyhausen GmbH & CO. KG
 Maschinenfabrik
 27793 Wildeshausen

AW-2601 / 1110-1140

Stromlaufplan PFE 2601

Blatt 1
 von 16 Bl.

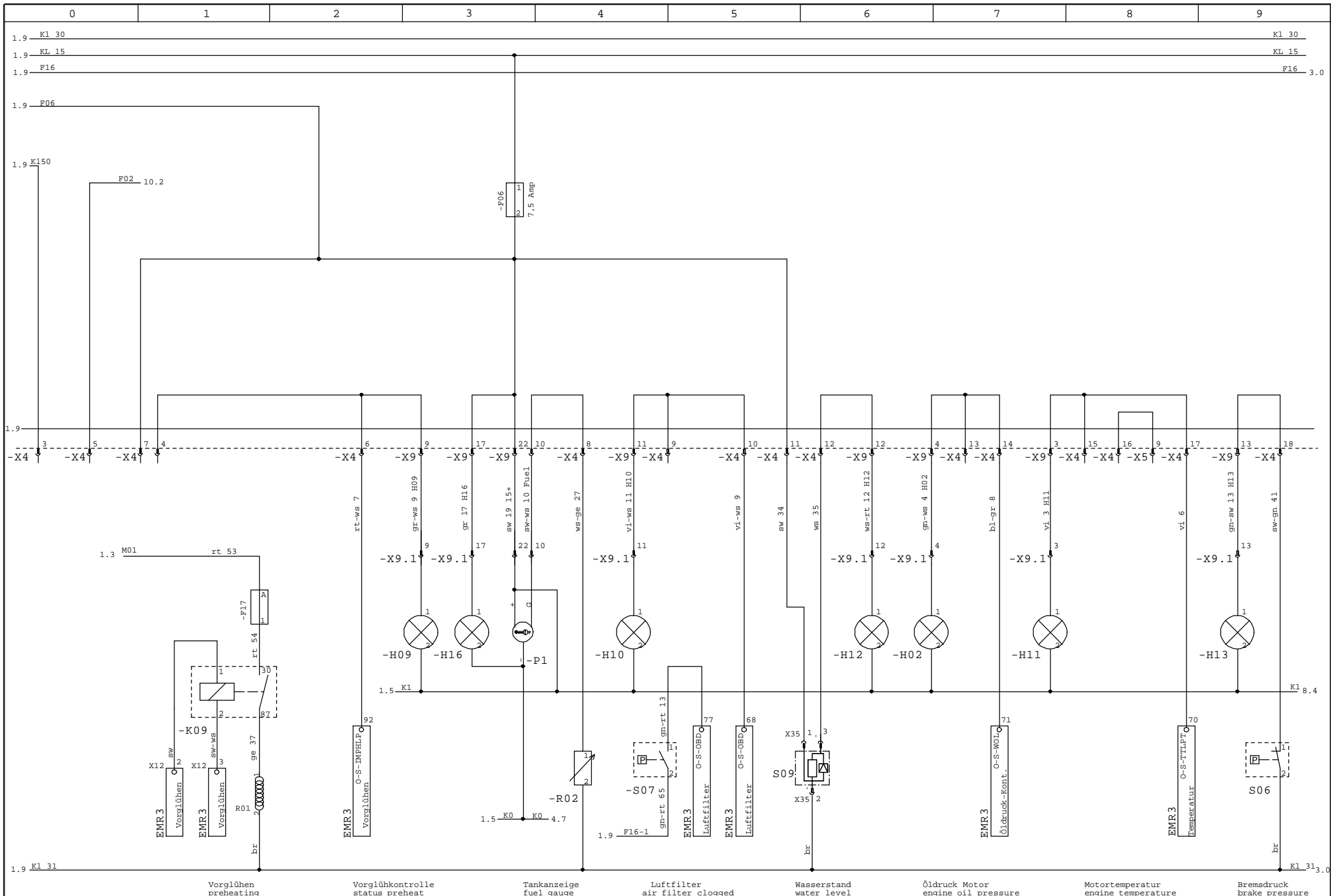

001	07.05.07	Heuer	Datum	07.05.2007
002	01.11.07	Heuer	Bearb.	W.Heuer
			Gepr.	
Zust.	Änderung	Datum	Name	Norm
			Urspr.	Ers.f

Vers 02

F.Weyhausen GmbH & CO. KG
 Maschinenfabrik
 27793 Wildeshausen

AW-2601 / 1110-1140

Stromlaufplan PFE 2601

Blatt 2
 von 16 Bl.

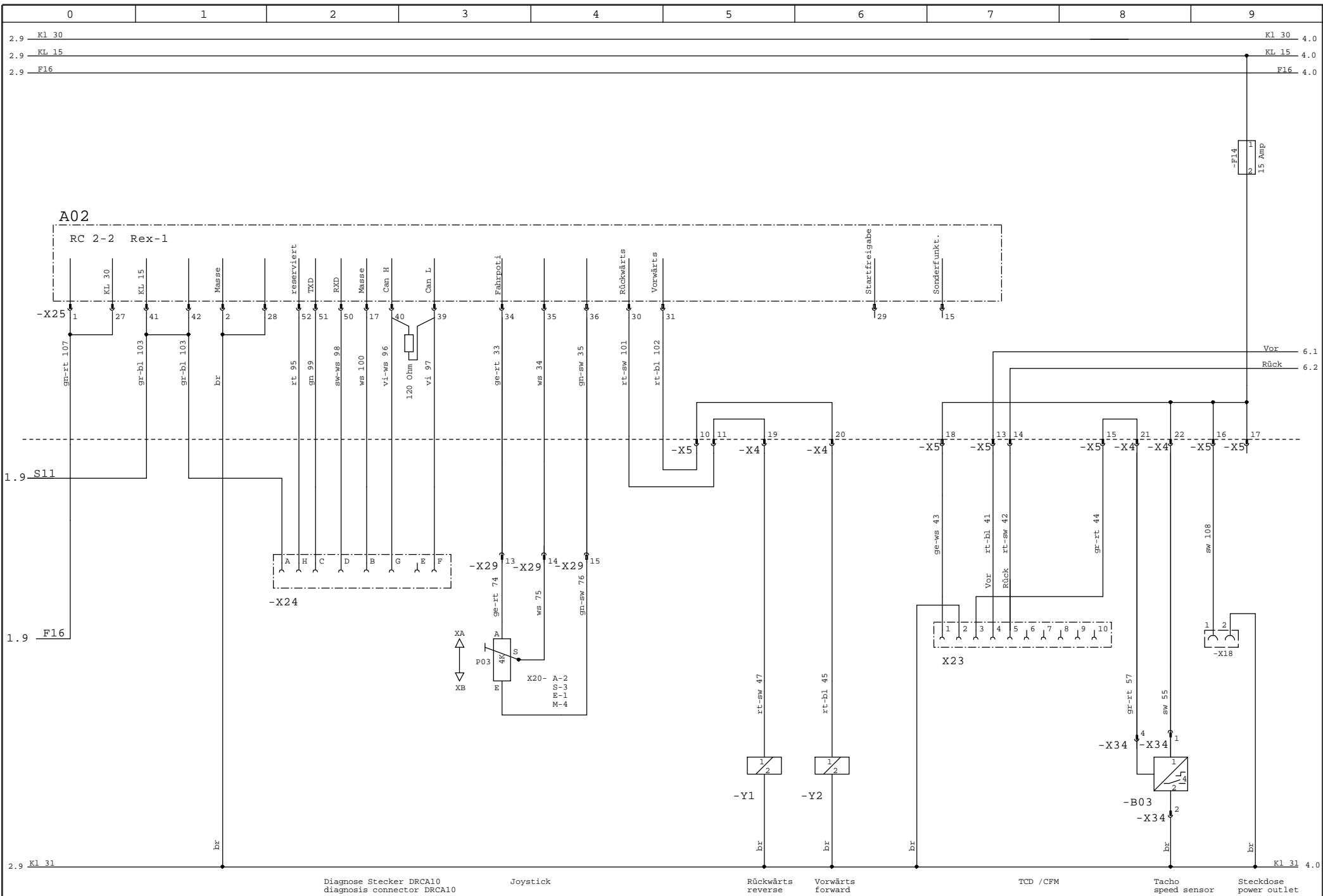

001	07.05.07	Heuer	Datum	07.05.2007
002	01.11.07	Heuer	Bearb.	W.Heuer
Zust.	Änderung	Datum	Name	Norm
			Urspr.	Ers.f

Vers 02

F.Weyhausen GmbH & CO. KG
 Maschinenfabrik
 27793 Wildeshausen

AW-2601 / 1110-1140

Stromlaufplan PFE 2601

Blatt 3
 von 16 Bl.

PFE 2601 ECO-Rex2 ohne K04 + K05

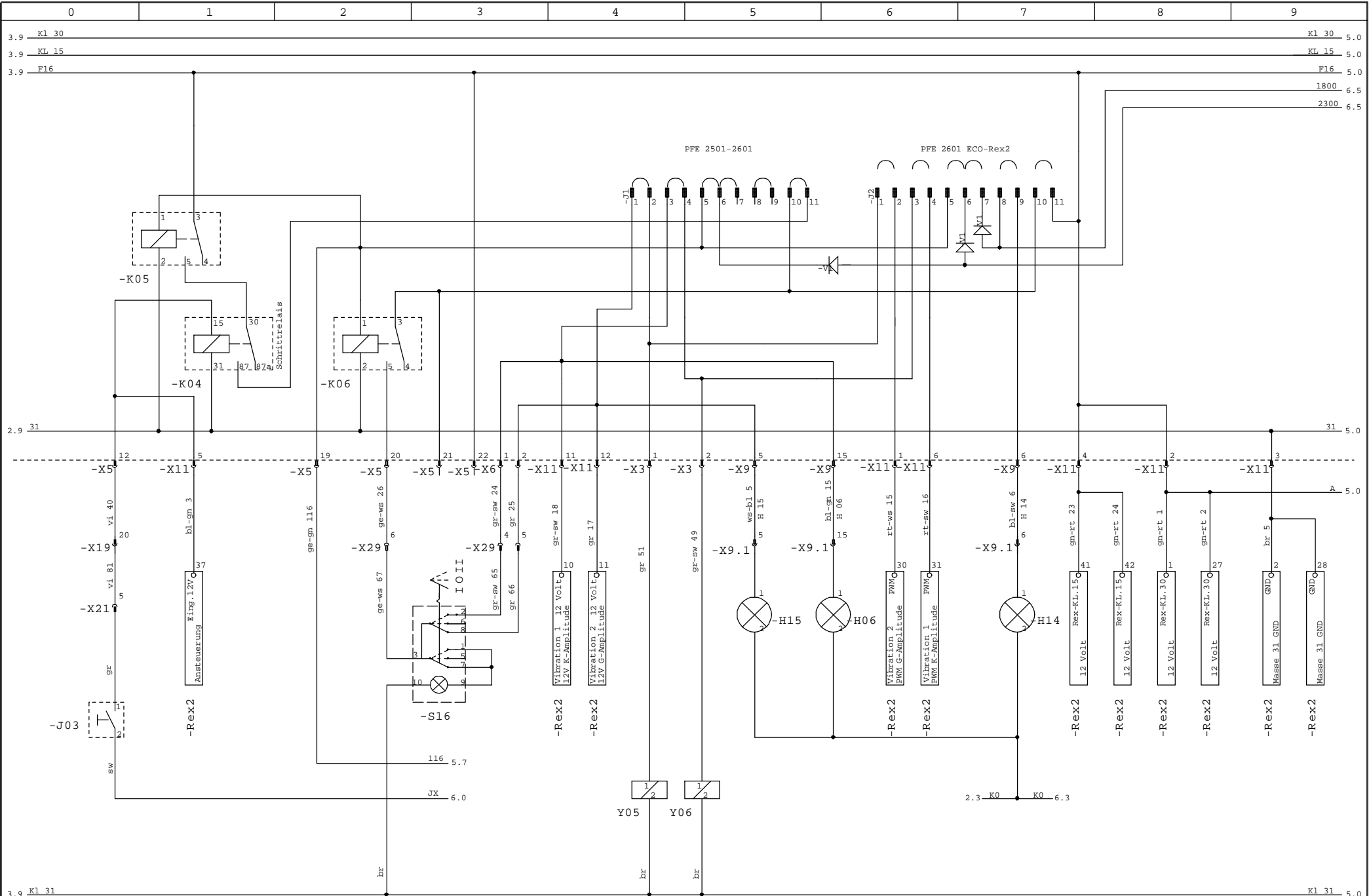

3.9 Kl 30	Kl 30 5.0	3.9 Kl 15	Kl 15 5.0	3.9 F16	F16 5.0	1800	6.5	2300	6.5
PFE 2501-2601 PFE 2601 ECO-Rex2									
-K05 -K04 -K06 Schrittrelais									
-X5 -X11 -X5 -X5 -X5 -X5 -X6 -X11 -X11 -X3 -X3 -X9 -X9 -X11 -X11 -X9 -X11 -X11 -X11 -X11									
-X19 -X21 -X29 -X9.1 -X9.1 -X11 -X11 -X9.1 -X11 -X11 -X11 -X11 -X11 -X11 -X11 -X11 -X11 -X11 -X11 -X11									
-Rex2 -Rex2 -Rex2 -Rex2 -Rex2 -Rex2 -Rex2 -Rex2 -Rex2 -Rex2 -Rex2 -Rex2 -Rex2 -Rex2 -Rex2 -Rex2 -Rex2 -Rex2 -Rex2 -Rex2									
H15 H06 H14 Rex-KL.15 Rex-KL.15 Rex-KL.30 Rex-KL.30 Masse 31 GND Masse 31 GND									
Vibration 1 12 Volt 12V K-Amplitude Vibration 2 12 Volt 12V G-Amplitude Vibration 1 PPM K-Amplitude Vibration 2 PPM G-Amplitude 12 Volt 12 Volt 12 Volt 12 Volt Masse 31 GND Masse 31 GND									
Y05 Y06 K0 K0									
Vibration Ein/Aus vibration on / off Wahlschalter Vibration vibration mode switch kleine Frequenz low frequency grosse Frequenz high frequency grosse Amplitude high amplitude kleine Amplitude small amplitude ECO									

001	07.05.07	Heuer	Datum	07.05.2007				AW-2601 / 1110-1140	
002	01.11.07	Heuer	Bearb.	W.Heuer				Stromlaufplan PFE 2601	Blatt 4
Zust.	Änderung	Datum	Name	Norm	Urspr.	Ers.f	Ers.d		von 16 Bl.

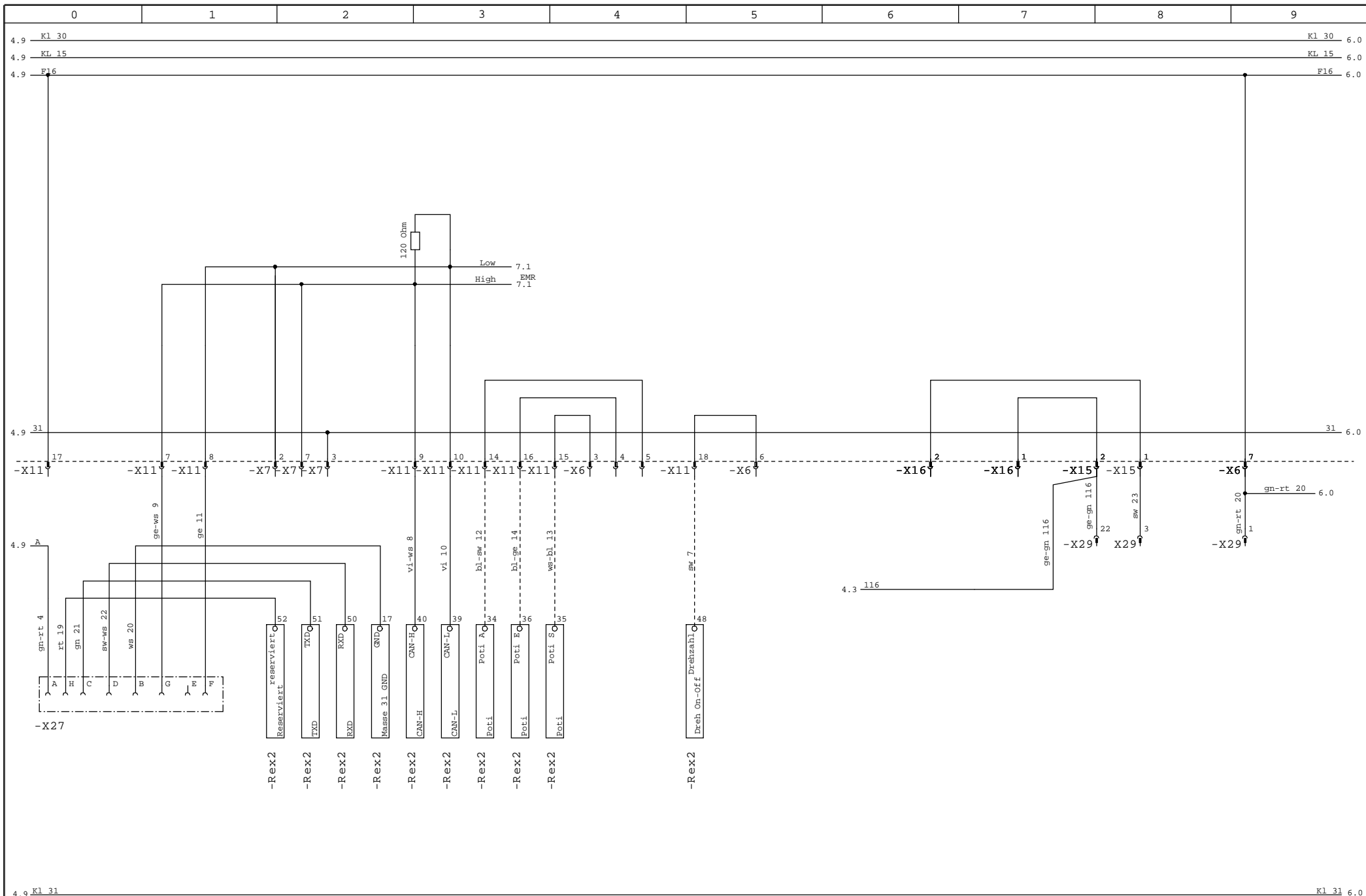

4.9 Kl 31 Kl 31 6.0

Diagnose Stecker SPC/WEY001
diagnosis connector SPC/WEY001

001	07.05.07	Heuer	Datum	07.05.2007		F.Weyhausen GmbH & CO. KG Maschinenfabrik 27793 Wildeshausen	AW-2601 /1110-1140	Stromlaufplan PFE 2601	Blatt 5 von 16 Bl.
002	01.11.07	Heuer	Bearb.	W.Heuer					
Zust.	Änderung	Datum	Name	Norm	Urspr.	Ers.f	Ers.d		

Vers 02

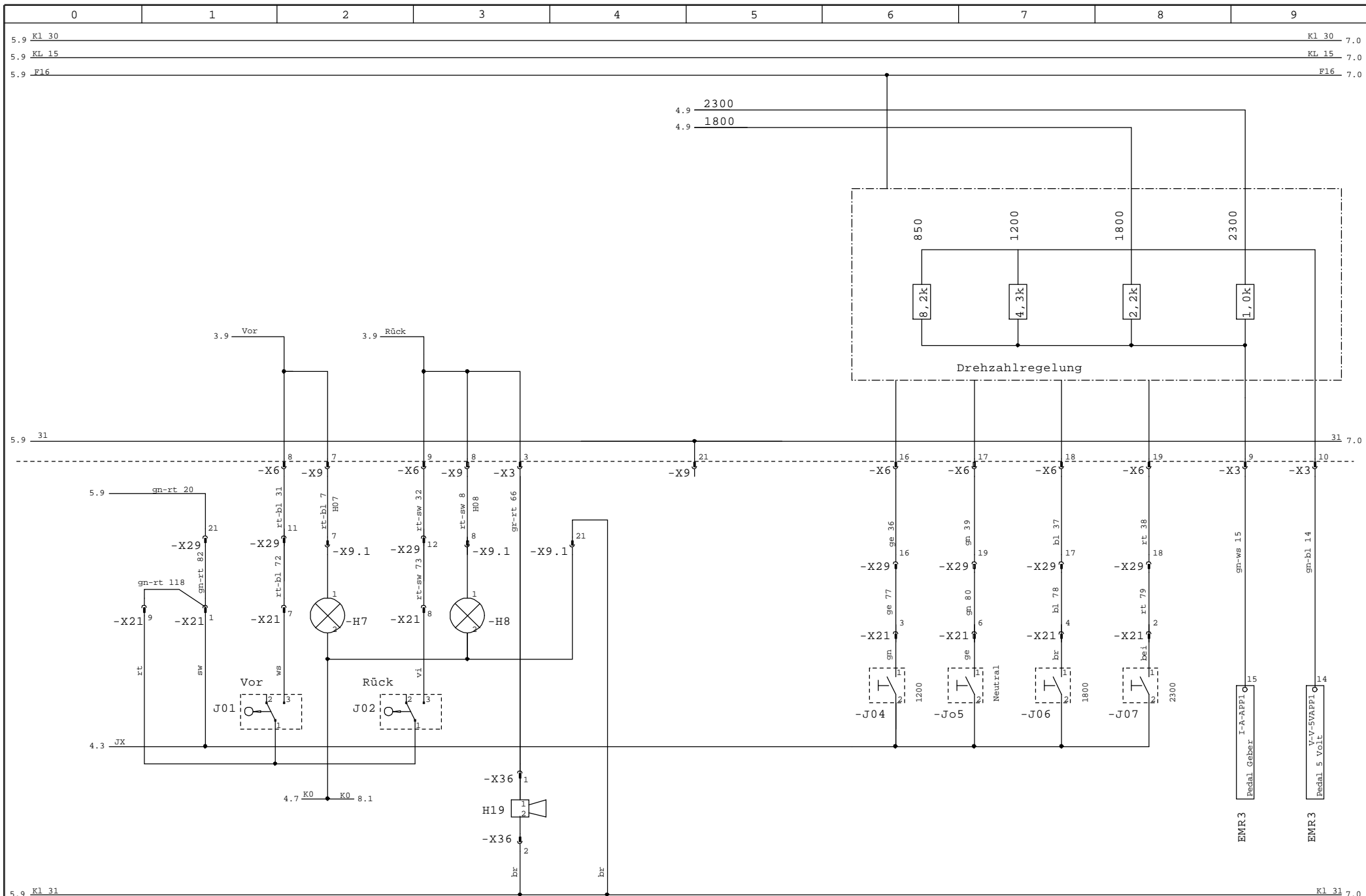

5.9 Kl 31
 vorwärts forward
 rückwärts reverse
 Rückfahrsummer backup alarm

001	07.05.07	Heuer	Datum	07.05.2007	F.Weyhausen GmbH & CO. KG Maschinenfabrik 27793 Wildeshausen	AW-2601 / 1110-1140	Stromlaufplan PFE 2601	Blatt 6 von 16 Bl.
002	01.11.07	Heuer	Bearb.	W.Heuer				
Zust.	Änderung	Datum	Name	Norm	Urspr.	Ers.f	Ers.d	Vers 02

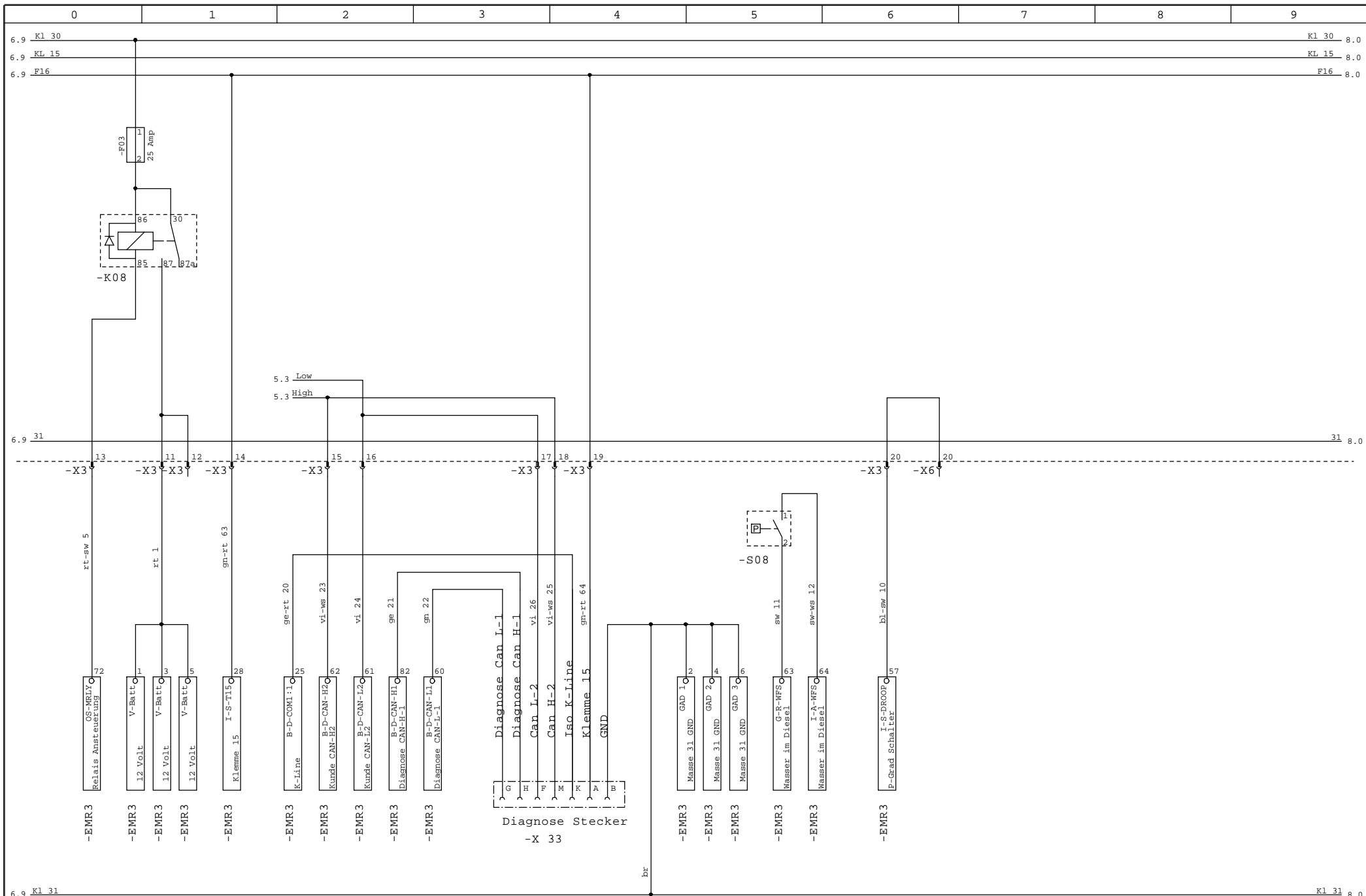

Diagnose Stecker EMR3
diagnosis connector EMR3

Wasser in Diesel
Water in fuel sensor

001	07.05.07	Heuer	Datum	07.05.2007
002	01.11.07	Heuer	Bearb.	W.Heuer
			Gepr.	
Zust.	Änderung	Datum	Name	Norm
			Urspr.	

F.Weyhausen GmbH & CO. KG
Maschinenfabrik
27793 Wildeshausen

AW-2601 /1110-1140	Blatt 7
Stromlaufplan PFE 2601	von 16 Bl.

Vers 02

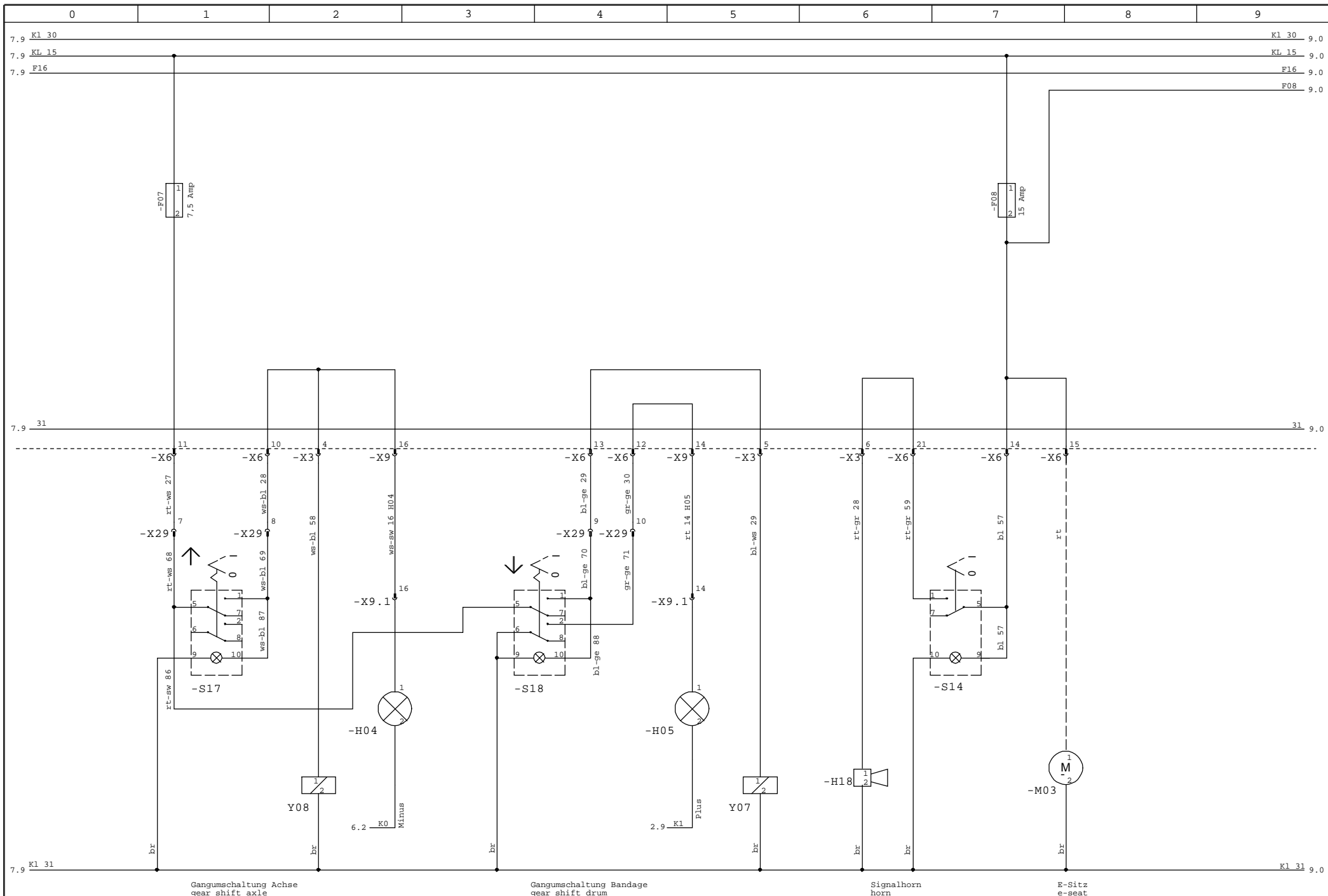

001	07.05.07	Heuer	Datum	07.05.2007
002	01.11.07	Heuer	Bearb.	W.Heuer
			Gepr.	
Zust.	Änderung	Datum	Name	Norm
			Urspr.	Ers.f
				Ers.d

Vers 02

F.Weyhausen GmbH & CO. KG
 Maschinenfabrik
 27793 Wildeshausen

AW-2601 / 1110-1140
Stromlaufplan PFE 2601
 Blatt 8
 von 16 Bl.

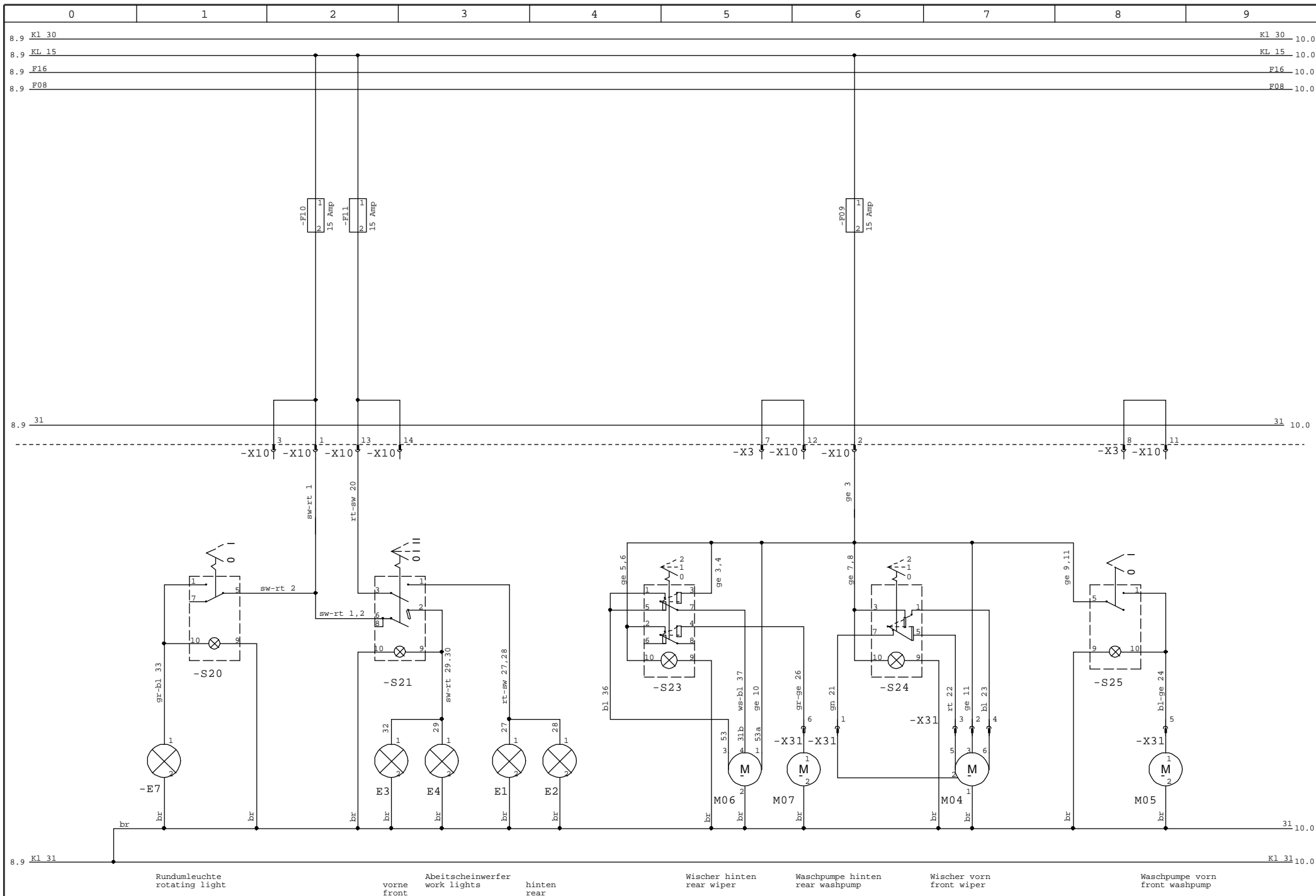

001	07.05.07	Heuer	Datum	07.05.2007								
002	01.11.07	Heuer	Bearb.	W.Heuer								
Zust.	Änderung	Datum	Name	Norm	Urspr.	Ers.f	Ers.d					

Vers 02

F.Weyhausen GmbH & CO. KG
 Maschinenfabrik
 27793 Wildeshausen

AW-2601 / 1110-1140

Stromlaufplan PFE 2601

Blatt 9
 von 16 Bl.

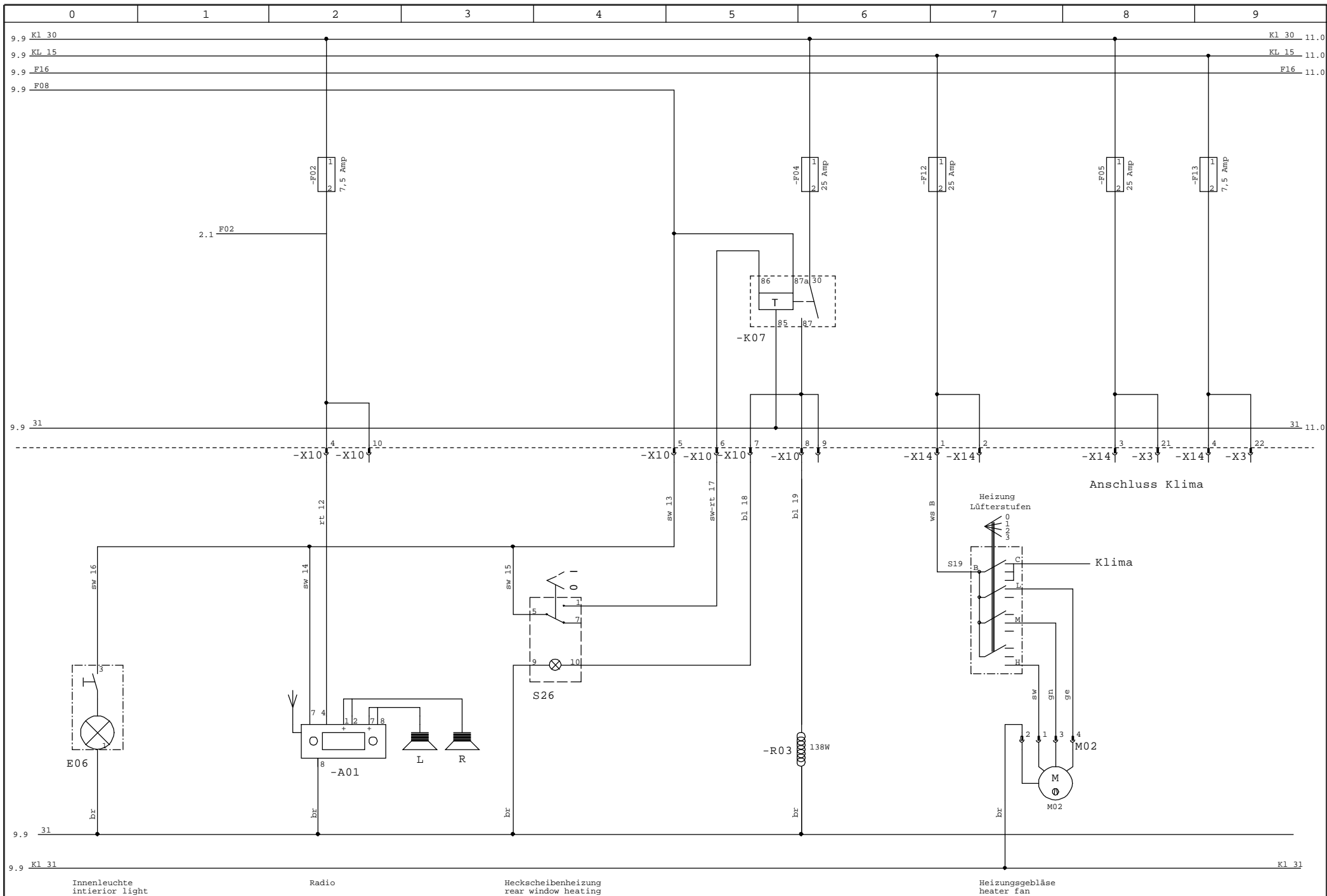

001	07.05.07	Heuer	Datum	07.05.2007	F.Weyhausen GmbH & CO. KG Maschinenfabrik 27793 Wildeshausen	AW-2601 / 1110-1140	Blatt 10
002	01.11.07	Heuer	Bearb.	W.Heuer			
Zust.	Änderung	Datum	Name	Norm	Urspr.	Ers.f	Ers.d

Vers 02

Stromlaufplan PFE 2601

von 16 Bl.

weiss	ws	white	wh
grau	gr	grey	gy
gelb	ge	yellow	ye
rosa	rs	pink	pk
rot	rt	red	rd
grün	gn	green	gn
blau	bl	blue	bl
braun	br	brown	bn
orange	or	orange	og
violett	vi	violet	vt
schwarz	sw	black	bk
türkis	tk	turquoise	tq



Chapter 10

Steering system & Articulated pendulum joint

Contents

This chapter provides you with information about:

- the steering system and the steering hydraulics
 - the components of the articulated pendulum joint
 - installing and dismantling the articulated pendulum joint
- 

10.1 Steering system and articulated pendulum joint



ATTENTION!

The articulated pendulum joint and the steering system constitute a single unit. Articulation of the front drum determines the turning angle of the compaction roller.

10.2 Steering system

- Hydraulic cylinders serve to effect the steering motions by retracting and extending.
- The steering hydraulics is powered by a hydraulic pump at the Diesel engine.
- The steering orbitrol (control block) is located underneath the steering column.
- The turning motion of the steering wheel controls the oil flow in the control block and causes the hydraulic cylinder at the articulated pendulum joint to retract and extend.
- The bigger the steering motion, the higher the turning angle (max. +/- 30 degrees).

10.2.1 Technical specifications

Measurement / Setting	Default values
Operating pressure steering system	180 bar
Pressure control valve	180 bar

10.2.2 Overview: Steering hydraulics and components

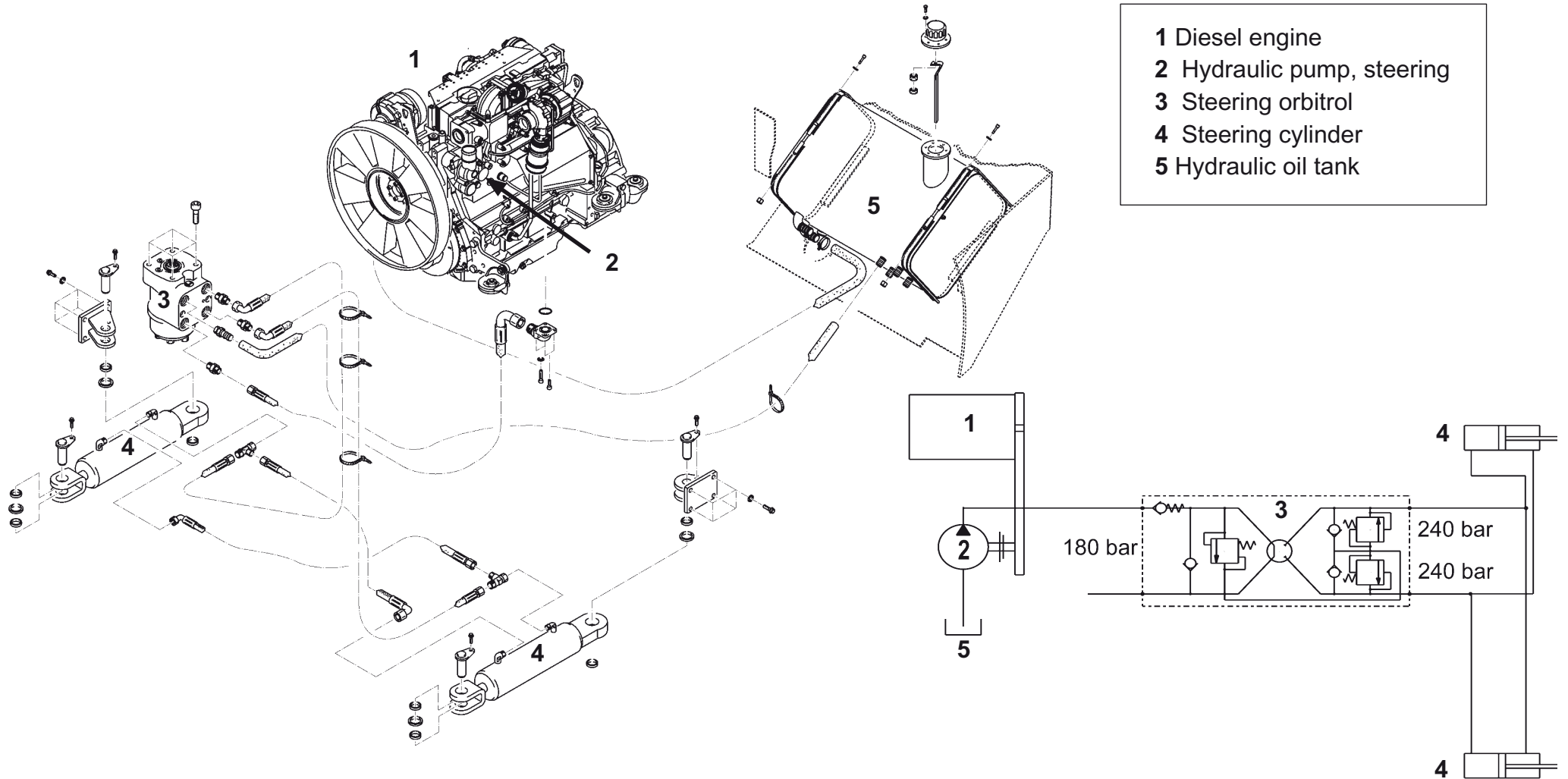

10.3 Articulated pendulum joint

- The articulated pendulum joint constitutes the link between the drum (front) frame and the basic (rear) frame of the compaction roller.
- The articulated pendulum joint serves to bend and pivot the drum frame.

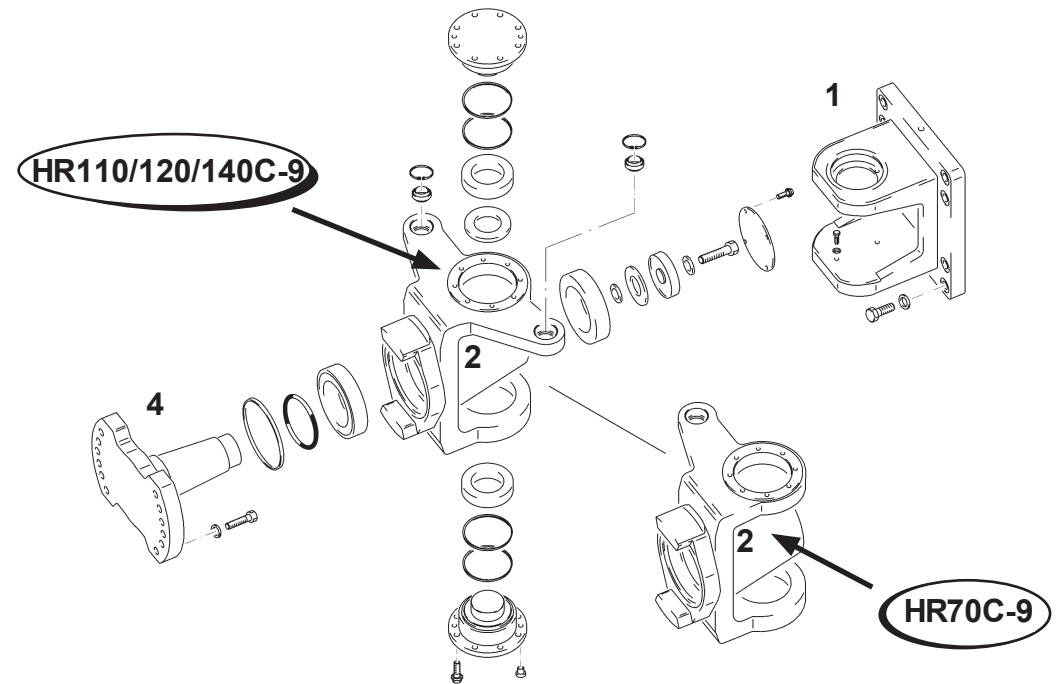
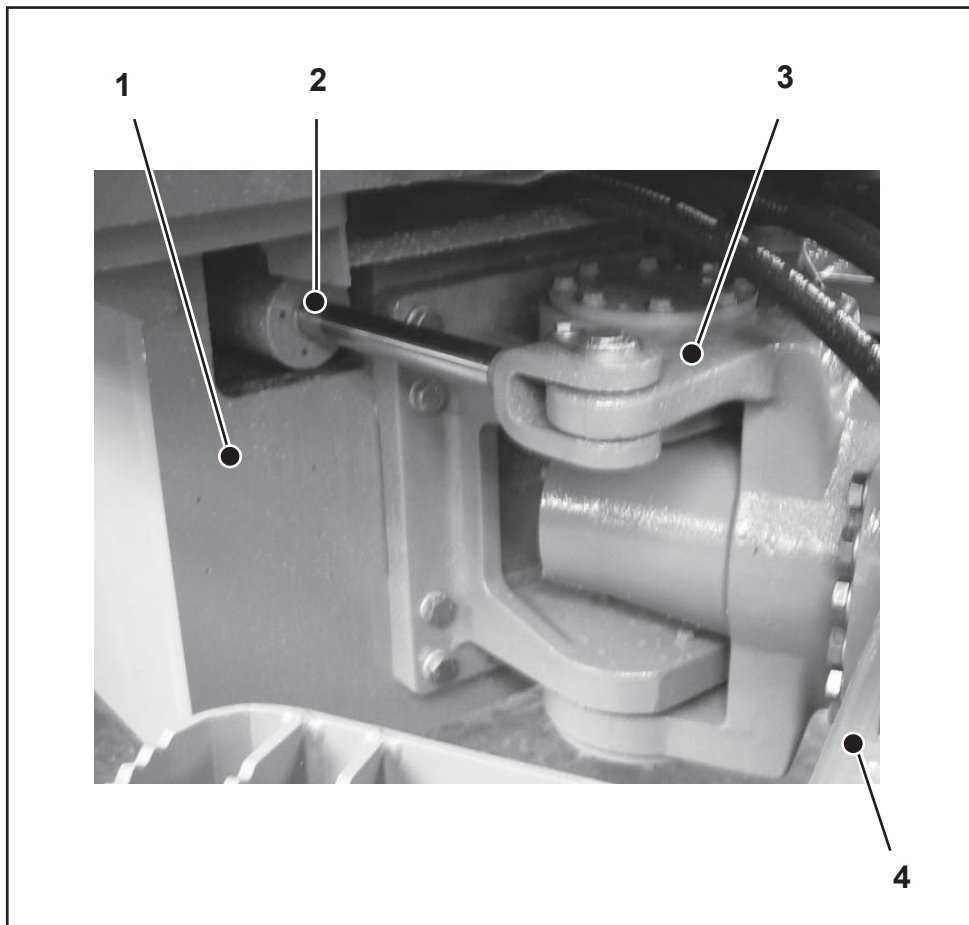

- 1 Basic (rear) frame
- 2 Steering cylinder
- 3 Articulated pendulum joint
- 4 Drum (front) frame

10.3.1 Installing and dismantling the articulated pendulum joint

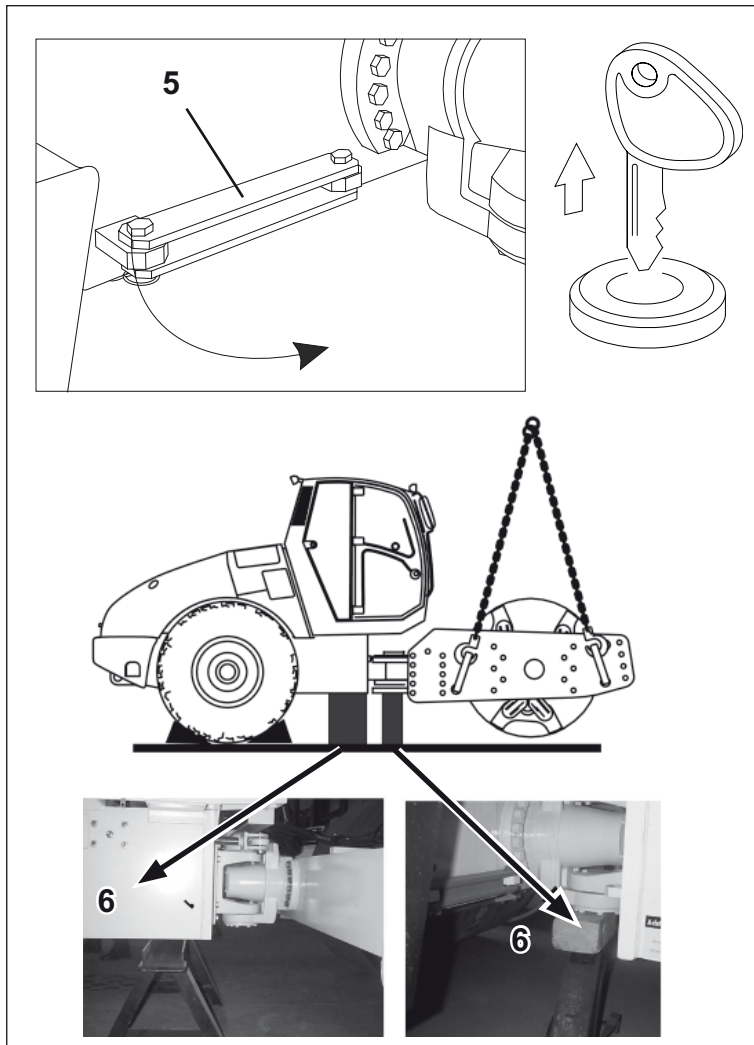

ATTENTION!

- In order to replace an articulated pendulum joint, take the compaction roller to a workshop, as this work may only be performed by trained service staff.
- Make sure that the crane to be used disposes of an appropriate lifting capacity before lifting the components.

Preparations to be carried out before dismantling and installing an articulated pendulum joint

- Prior to starting work, secure the compaction roller to prevent it from rolling.
- Pull out the ignition key.
- Apply the parking brake.
- Insert the anti-buckling device (5) between the drum (front) frame and the basic (rear) frame.
- Secure the wheels by means of wheel chocks.
- Slightly lift the drum frame.
- Place supports (6) both under the front part of the basic frame and underneath the articulated pendulum joint.

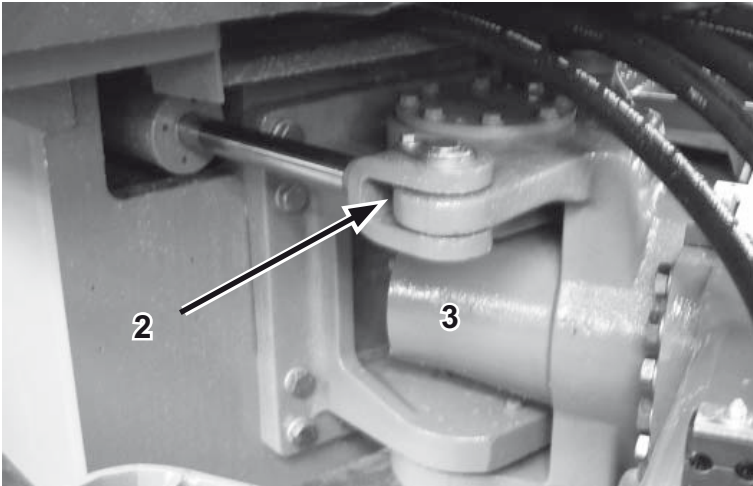

Dismantling the steering cylinders of the articulated pendulum joint

- Prior to removing the articulated pendulum joint, dismantle the steering cylinders (2).
- Unscrew the safety screws (2.1) from the steering bolts (2.2) and press the bolts upwards, out of the cylinder fork and the articulated pendulum joint (3)

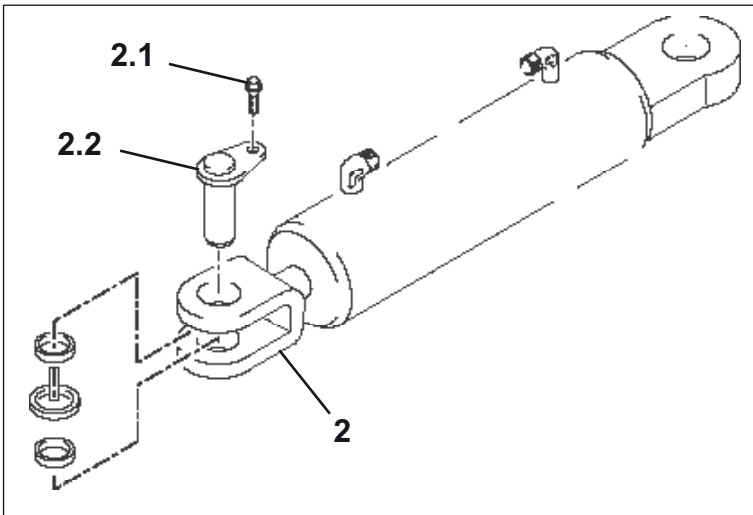

Dismantling the articulated pendulum joint

- Position a lift truck with a pallet under the articulated pendulum joint.
- Lift the pallet so it is located right underneath the articulated pendulum joint.
- Unscrew the screws (3.1) of the connection between the basic (rear) frame and the articulated pendulum joint (1/3).
- Remove the screws (3.2) from the connection between the drum (front) frame and the articulated pendulum joint (2/3).
- Use the lift truck to lower the disconnected articulated pendulum joint (3) to the ground.

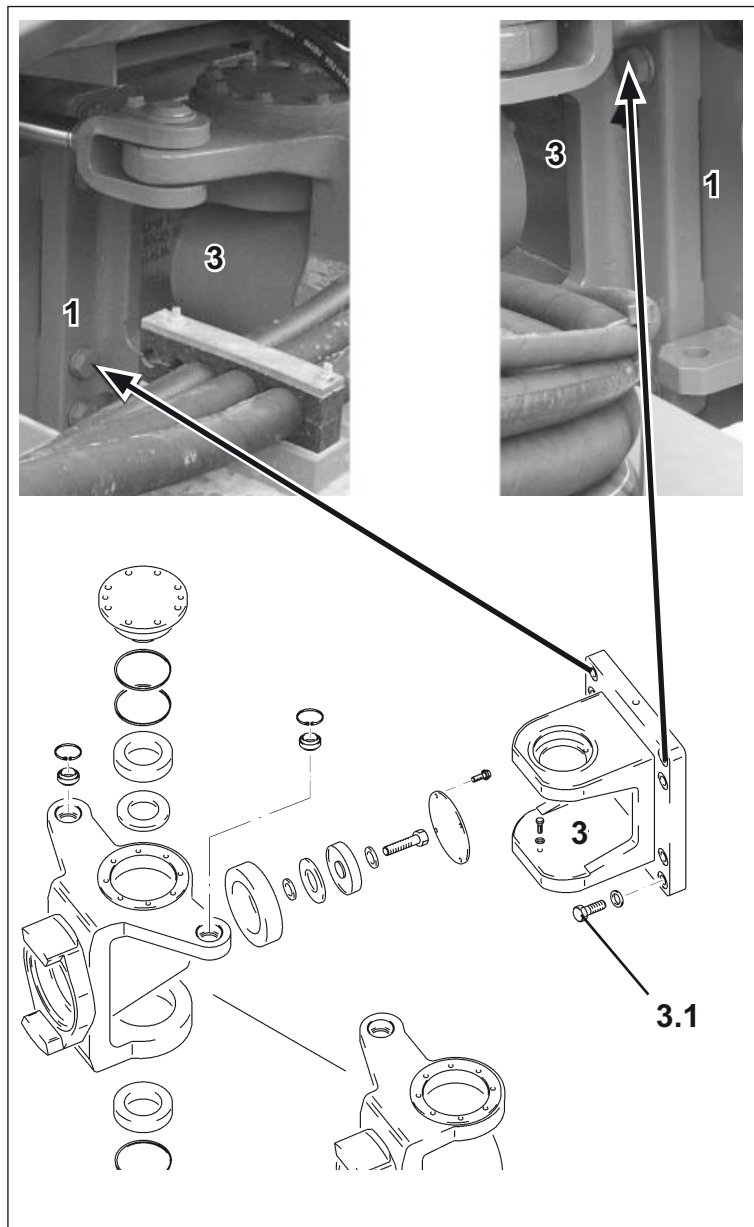
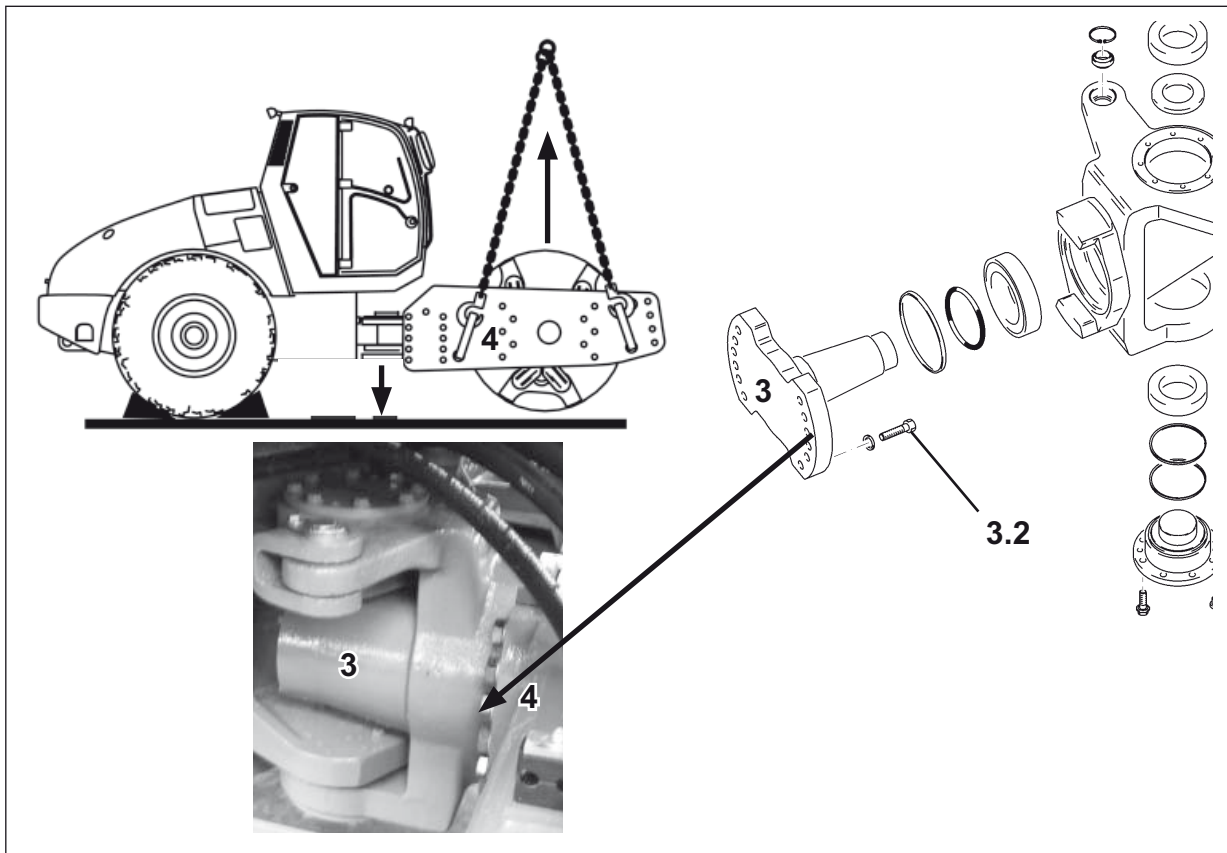

Replacing and installing an articulated pendulum joint



ATTENTION!

- Any repair work related to the articulated pendulum joint may only be performed by trained service staff, using special tools at the place of manufacture.
- Always replace the entire articulated pendulum joint.

- To carry out the installation, put the new articulated pendulum joint (3) onto the pallet of the lift truck and position the pallet underneath the drum area.
- By means of the lift truck, lift the articulated pendulum joint to a height which enables you to establish the screw connections (3.2) between the articulated pendulum joint (3) and the drum frame (4).
- By means of the crane, slightly lower the drum frame and align the angle of the articulated pendulum joint (3) with the basic frame (1).
- Establish the screw connections (3.1) between the articulated pendulum joint (3) and the basic frame (1).
- Tighten all screws crosswise and to the correct torque (see table of tightening torques).

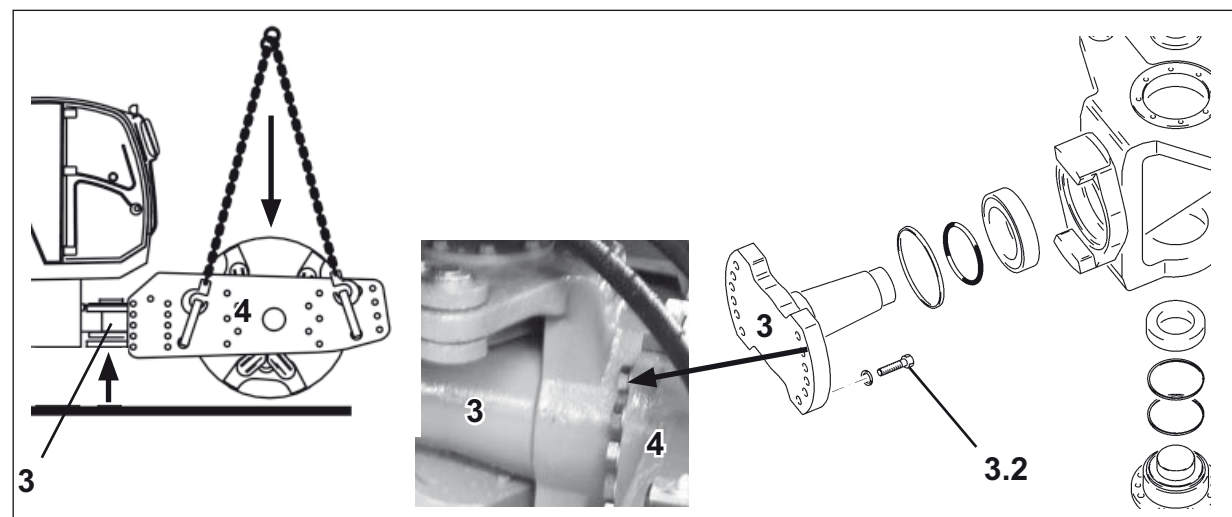



Chapter 11

Towing the compaction roller

Contents

This chapter provides you with information about:

- towing the compaction roller



11.1 Towing the compaction roller

11.1.1 Safety instructions referring to towing the compaction roller



CAUTION!

Precautionary measures to be taken prior to towing the compaction roller!

- The precautionary measures related to towing as well as the towing process itself may only be carried out by experienced individuals who have undergone the appropriate training required for this type of work.
- Make sure the towing vehicle disposes of the required trailer load capacity / tractive force!
- The overall weight of the compaction roller needs to be taken into account (see chapter **Technical specifications**).



WARNING!

The compaction roller may only be towed if its emergency steering is in working order.



WARNING!

Material damage!

The preparations at the travel hydraulics and the parking brake must be completed prior to towing the compaction roller.

Set the towing vehicle in motion very slowly and carry out the towing process at a low speed.

11.1.2 Precautionary measures to be taken prior to towing

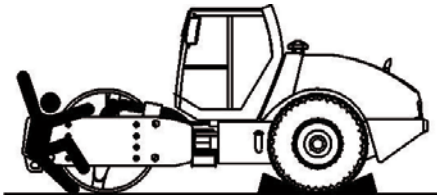

HR70C-9: 4 mm socket head wrench
HR110/120/140C-9: 5 mm socket head wrench

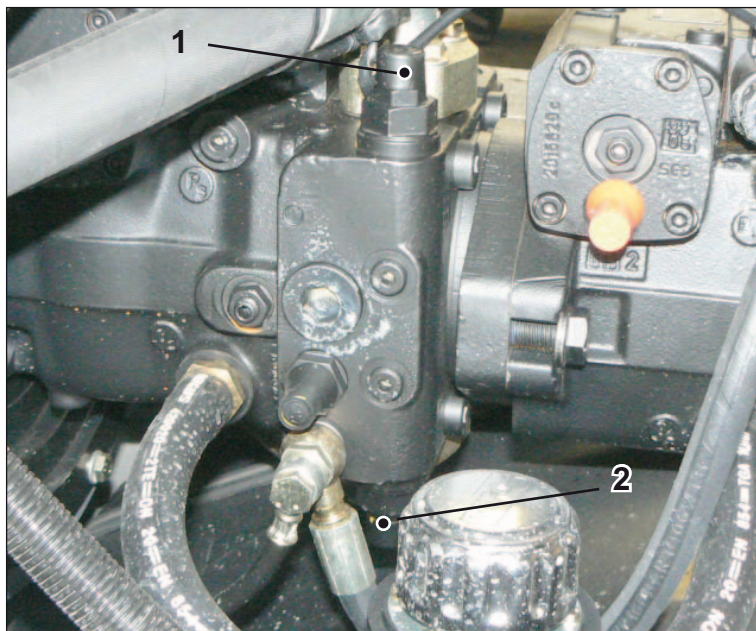

Securing the compaction roller



DANGER!

Risk of death!

Use the wheel chocks to prevent the compaction roller from rolling, since there is no braking effect after releasing the parking brake and the HP valves!

- Place wheel chocks under the wheels.



WARNING!

Operation on slopes!

If the compaction roller is parked on a slope and needs to be towed, make sure that the rear wheels and the drum are adequately secured!

Releasing the parking brake and the HP valves



WARNING!

Risk of death!

If the compaction roller is not properly secured against rolling, you must **not** carry out any of the work described below!

Opening the HP valves at the travel pump

- In order to tow the compaction roller, short-circuit the hydraulic circuit between the traction pump and the hydraulic traction motors.
- Access the HP valves from the left side of the engine compartment (in the direction of motion).
- **Type 70:** In order to loosen the HP valves (1) and (2), use the socket head wrench to screw in the adjusting spindles until they are level with the valve housing.
- **Types 110/120/140 :** Loosen the socket head screw by 3 turns. Note that there is **no** counter nut for the socket head screw!

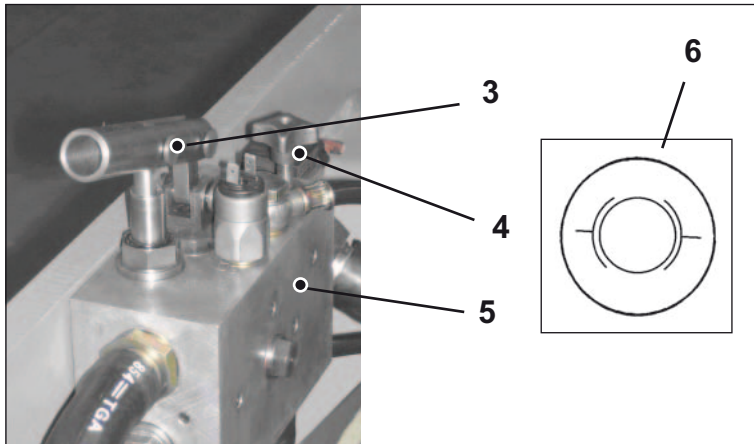

Deactivating (releasing) the parking brake

- In order to tow the compaction roller, you need to release the parking brake in the rear axle and in the drum via the hand pump (5).
- The hand pump (5) is installed in the engine compartment (on the left side, in the direction of motion).
- Put a pipe extension into the pump actuation (3).
- Close the relief valve (4).
- Build up pressure by manually pumping, which releases the parking brake und causes the corresponding light on the dashboard (brake pressure, 6) to go out.
- Remove the pipe extension.

11.1.3 Carrying out the towing process



WARNING!

Material damage!

- The preparations at the travel hydraulics and the parking brake must be completed prior to towing the compaction roller.
- The compaction roller may only be towed if its emergency steering is in working order.
- Set the towing vehicle in motion very slowly and carry out the towing process at low speed. The compaction roller may only be towed within a closed off work zone and not further than is absolutely necessary in order to remove it from the immediate danger / work zone!

- First of all, secure the compaction roller against rolling by establishing the connection with the towing vehicle.
- Remove the wheel chocks and any additional safety equipment used for preventing the compaction roller from rolling.
- The towing distance is to be kept as short as possible.

11.1.4 After the towing process

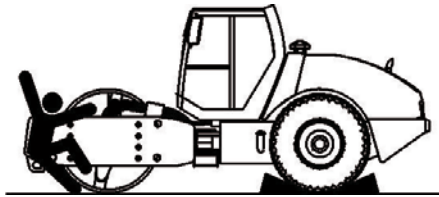

HR70C-9: 4 mm socket head wrench
HR110/120/140C-9: 5 mm socket head wrench

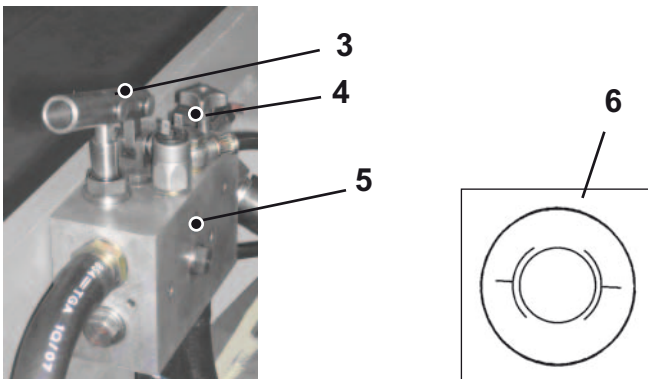
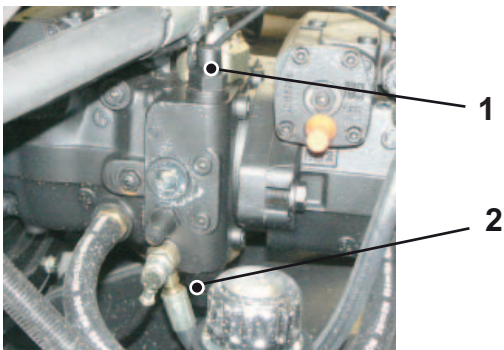

Securing the vehicle against rolling



DANGER!

Risk of death!

Immediately after completing the towing process, secure the compaction roller against rolling by means of the wheel chocks.

- After the towing process, the hydraulic circuit between the traction pump and the traction motor must be closed and the parking brake needs to be put in working order again.

Closing the HP valves at the traction pump

- Access the HP valves from the left side of the engine compartment (direction of motion).
- **HR70C-9:** In order to activate the HP valves (1 and 2), screw off the socket head screw and tighten the counter nut.
- **HR110/120/140C-9:** Completely screw in the socket head screw (10 Nm).

Activating the parking brake

- After towing the compaction roller, you need to activate the parking brake in the rear axle again.
- The hand pump (5) is situated in the engine compartment, on the left side (direction of motion).
- Slowly open the relief valve (4).
- The oil pressure escapes in the tank and the parking brake is activated, which is confirmed by the display on the dashboard, where the corresponding symbol (6) needs to light up.