

SECTION 6 WORK EQUIPMENT

Group 1 Structure and Function	6-1
Group 2 Operational Checks and Troubleshooting	6-39
Group 3 Tests and Adjustments	6-50
Group 4 Disassembly and Assembly	6-64

SECTION 6 WORK EQUIPMENT

GROUP 1 STRUCTURE AND FUNCTION

1. HYDRAULIC SYSTEM OUTLINE

The loader hydraulic system is a pilot operated, closed center system which is supplied with flow from the variable displacement piston main hydraulic pump.

The loader system components are :

- Loader pump
- Main control valve
- Bucket cylinder
- Boom cylinders
- Remote control valve (Pilot control valve, EH type)
- Safety valve

Flow from the steering pump not used by the steering system leaves the flow amplifier EF port. It flows to the inlet port plate of two section or three section block type main control valve.

The main control valve is load pressure independent flow distribution system which routes flow to the boom, bucket or auxiliary cylinders (not shown) when the respective spools are shifted.

Flow from the loader pump is routed to the main control valve where pump outlet pressure is reduced to pilot circuit pressure. The main control valve flow to the remote control valve.

The remote control valve routed flow to either end of each spool valve section in the main control valve to control spool stroke.

A accumulator mounted on safety valve supplies a secondary pressure source to operated remote control valve so the boom can be lowered if the engine is off.

The return circuit for the main hydraulic system have return filter inside the hydraulic tank. The return filter uses a filter element and a bypass valve. The bypass valve is located in the upside of filter.

2. HYDRAULIC CIRCUIT

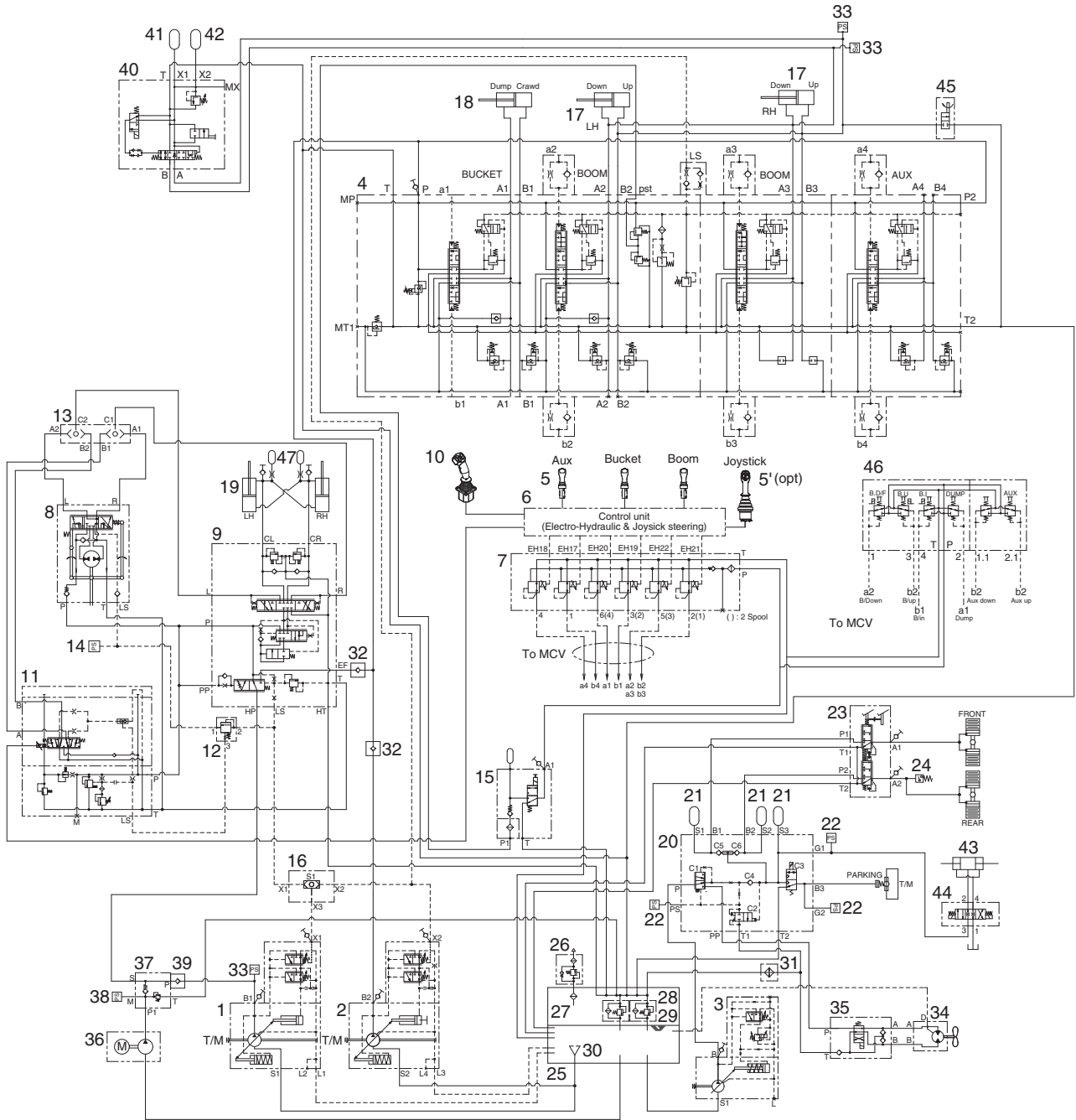

- | | | | | | |
|-------|-------------------------------|----|-------------------|----|------------------------------|
| 1 | Steering pump | 17 | Boom cylinder | 33 | Pressure sensor |
| 2 | Loader pump | 18 | Bucket cylinder | 34 | Fan motor |
| 3 | Fan & brake pump | 19 | Steering cylinder | 35 | Directional valve |
| 4 | Main control valve | 20 | Cut-off valve | 36 | Pump motor (opt) |
| 5, 5' | RCV (EH type, FNR type) | 21 | Accumulator | 37 | Check block (opt) |
| 6 | Control unit | 22 | Pressure sensor | 38 | Pressure sensor (opt) |
| 7 | EH control block | 23 | Brake valve | 39 | Check valve (opt) |
| 8 | Steering unit | 24 | Pressure switch | 40 | Ride control valve (opt) |
| 9 | Flow amplifier | 25 | Hydraulic tank | 41 | Accumulator (opt) |
| 10 | Joystick steering lever (opt) | 26 | Air breather | 42 | Accumulator (opt) |
| 11 | Proportional valve (opt) | 27 | Strainer | 43 | Quick coupler cylinder (opt) |
| 12 | LS compensating valve (opt) | 28 | Return filter | 44 | Solenoid valve (opt) |
| 13 | Shuttle valve (opt) | 29 | By pass valve | 45 | Manual boom lowering valve |
| 14 | Pressure sensor (opt) | 30 | Strainer | 46 | HYD control block (opt) |
| 15 | Safety valve | 31 | Hyd oil cooler | 47 | Accumulator |
| 16 | Shuttle valve | 32 | Check valve | | |

9806WE01

3. WORK EQUIPMENT HYDRAULIC CIRCUIT

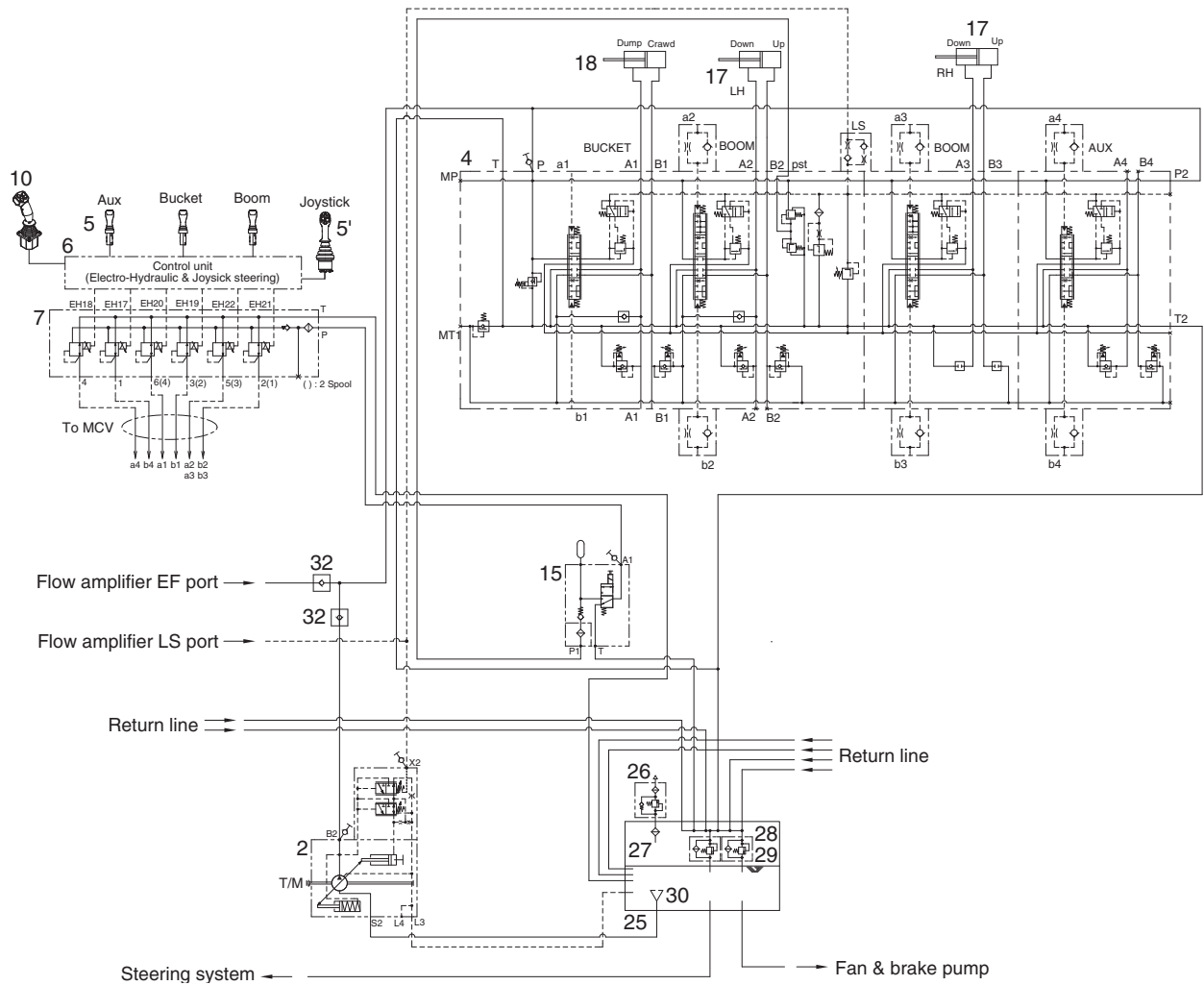

- | | | | | | |
|-------|-------------------------------|----|-----------------|----|---------------|
| 2 | Loader pump | 15 | Safety valve | 28 | Return filter |
| 4 | Main control valve | 17 | Boom cylinder | 29 | Bypass valve |
| 5, 5' | RCV (EH type, FNR type) | 18 | Bucket cylinder | 30 | Strainer |
| 6 | Control unit | 25 | Hydraulic tank | 32 | Check valve |
| 7 | EH control block | 26 | Air breather | | |
| 10 | Joystick steering lever (opt) | 27 | Strainer | | |

9806WE02

1) WHEN THE RCV LEVER IS IN THE RAISE POSITION

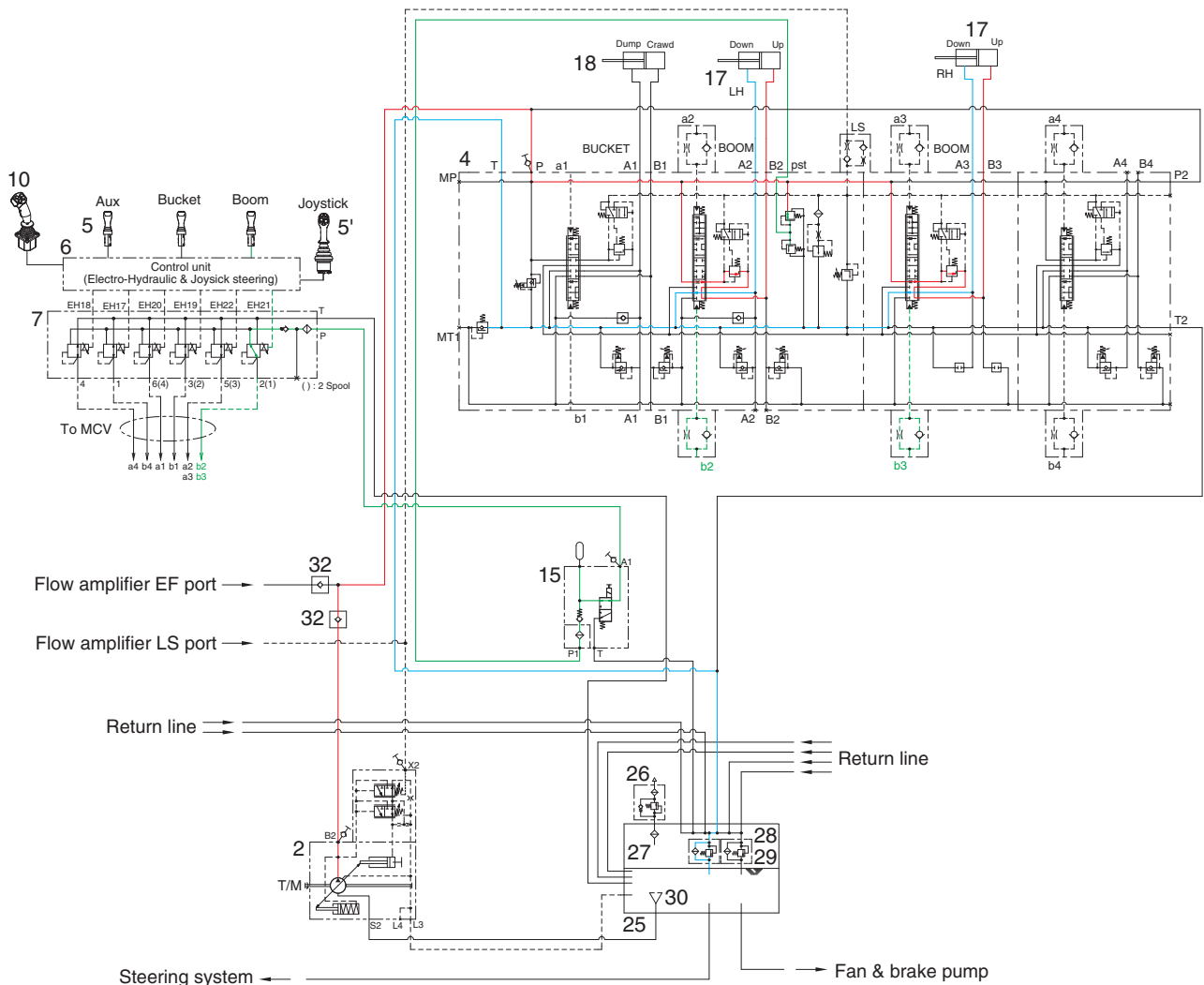

9806WE03

- When the EH RCV lever (5, boom) is pulled back, the boom spool is moved to raise position by pilot oil pressure from EH control block (7).
- The oil from loader pump (2) flows into main control valve (4) and then goes to the large chamber of boom cylinder (17) by pushing the load check valve of the boom spool.
- The oil from the small chamber of boom cylinder (17) returns to hydraulic oil tank (25) through the boom spool at the same time.
- When this happens, the boom goes up.

2) WHEN THE RCV LEVER IS IN THE LOWER POSITION

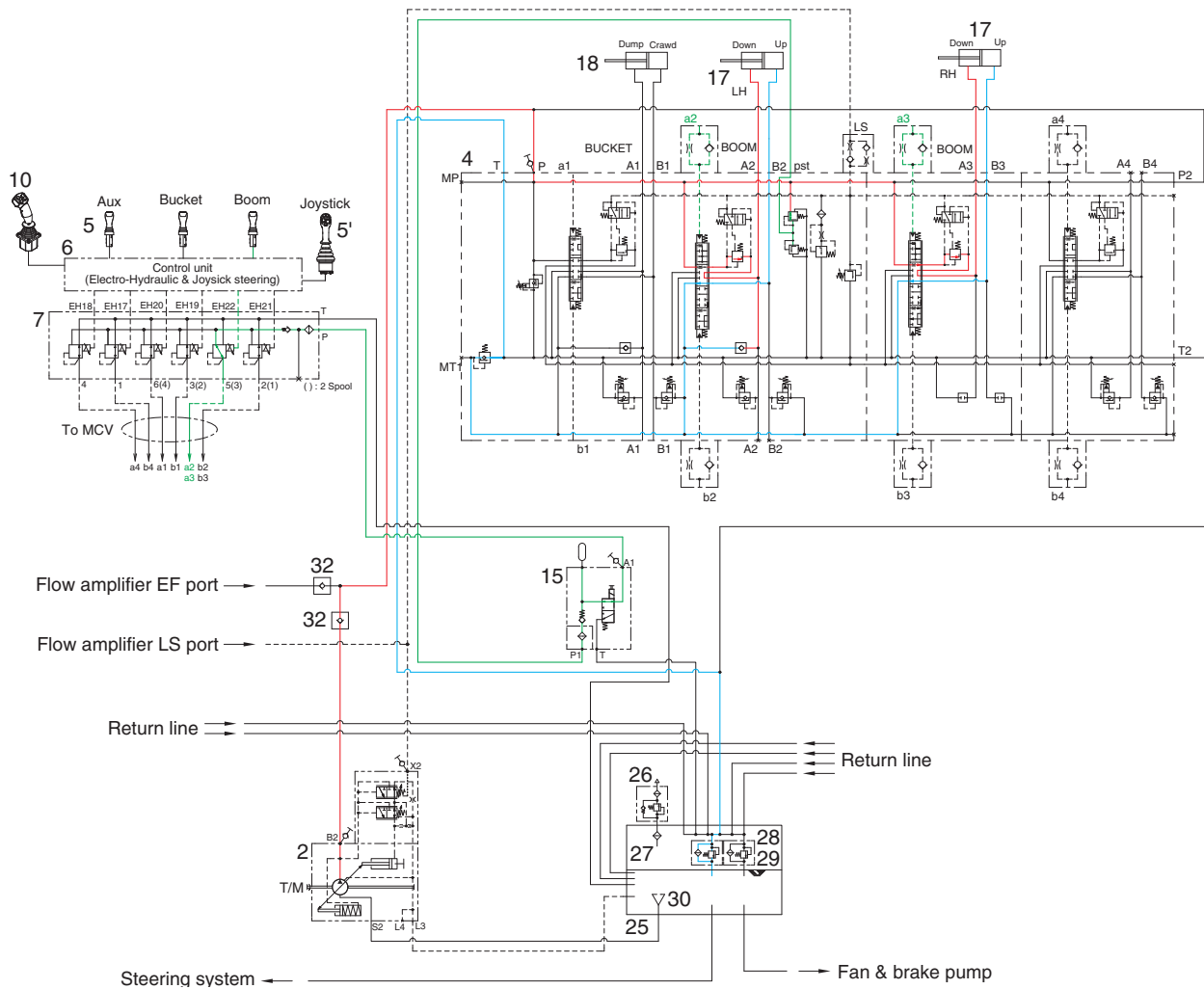

9806WE04

- When the EH RCV lever (5, boom) is pushed forward, the boom spool is moved to lower position by pilot pressure from EH control block.
- The oil from loader pump (2) flows into main control valve (4) and then goes to small chamber of boom cylinder (17) by pushing the load check valve of the boom spool.
- The oil returned from large chamber of boom cylinder (17) returns to hydraulic tank (25) through the boom spool at the same time.
- When the lowering speed of boom is faster, the return oil from the large chamber of boom cylinder combines with the oil from the pump through the regeneration check valve, and flows into the small chamber of the cylinder. This prevents cylinder cavitation by the negative pressure when the pump flow cannot match the boom down speed.

3) WHEN THE RCV LEVER IS IN THE FLOAT POSITION

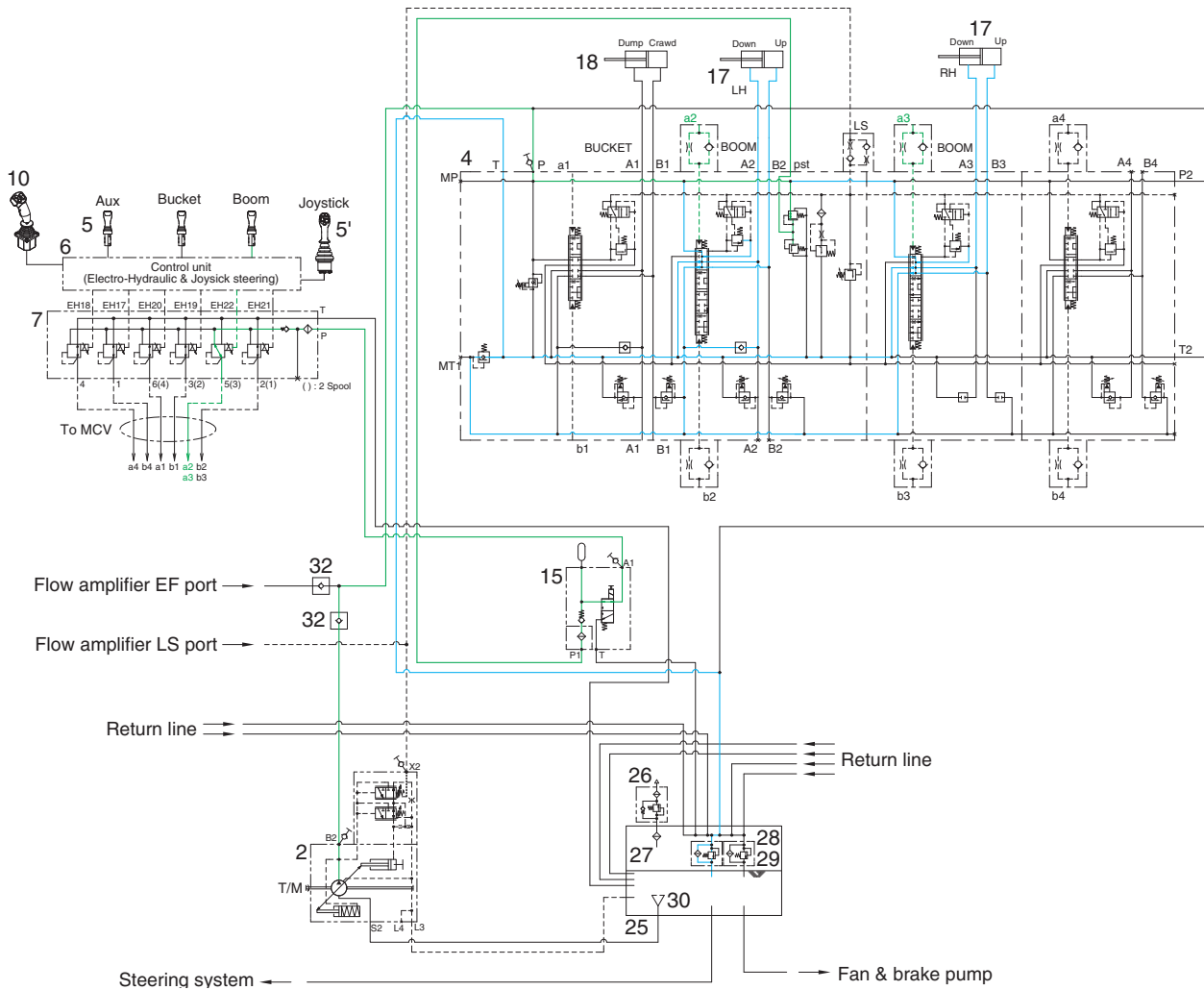

9806WE05

- When the EH RCV lever (5, boom) is pushed further forward from the lower position, the pilot pressure reaches to 13~15bar, then the boom spool is moved to floating position.
- The work ports (A2), (B2), (A3), (B3) and the small chamber and the large chamber are connected to the return passage, so the boom will be lowered due to its own weight.
- In this condition, when the bucket is in contact with the ground, it can be move up and down in accordance with the shape of the ground.

4) WHEN THE RCV LEVER IS IN THE DUMP POSITION

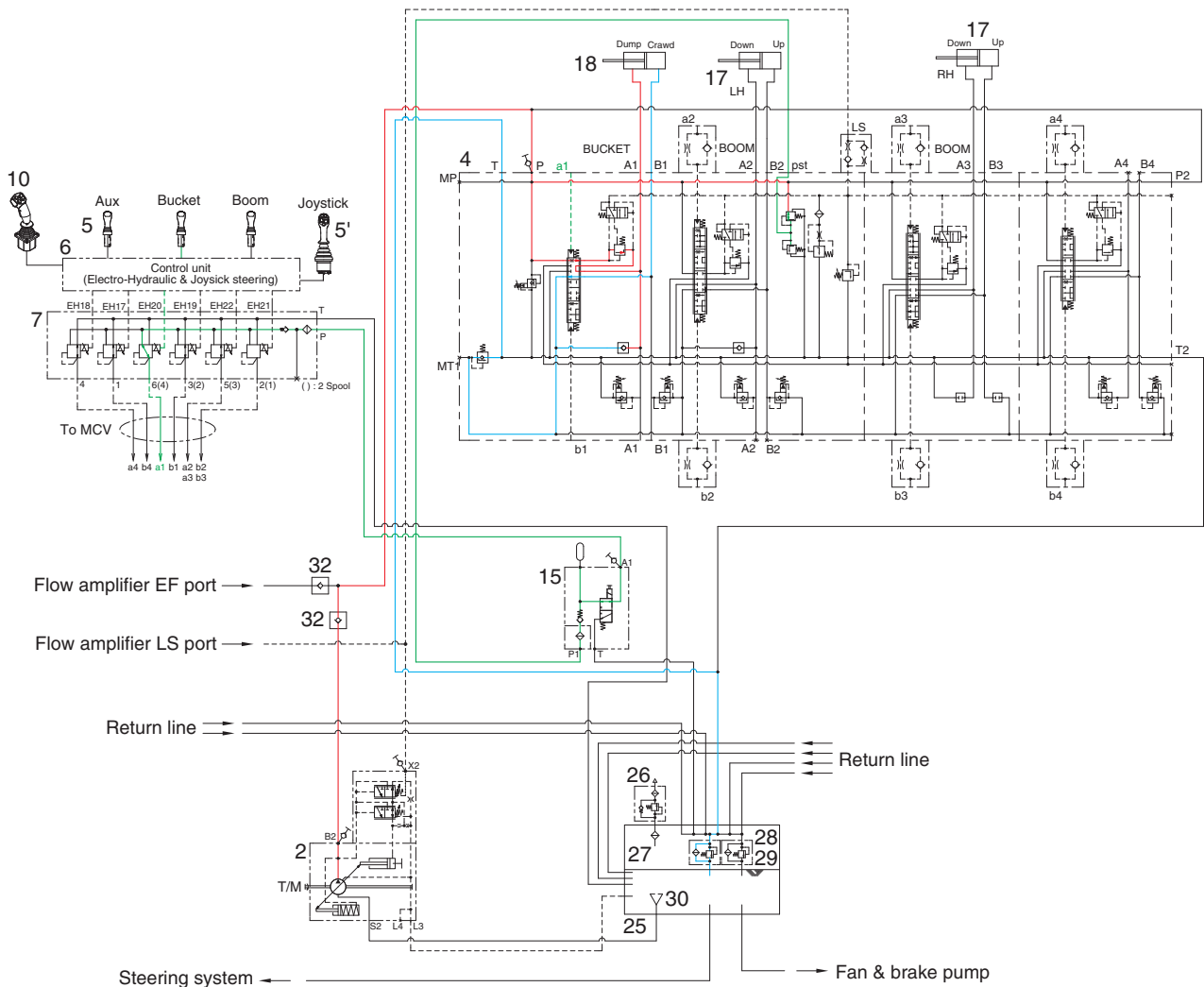

9806WE06

- If the EH RCV lever (5, bucket) is pushed right, the bucket spool is moved to dump position by pilot oil pressure from EH control block.
- The oil from loader pump (2) flows into main control valve (4) and then goes to the small chamber of bucket cylinder (18) by pushing the load check valve of the bucket spool.
- The oil at the large chamber of bucket cylinder (18) returns to hydraulic tank (25).
- When this happens, the bucket is dumped.
- When the dumping speed of bucket is faster, the oil returned from the large chamber of bucket cylinder combines with the oil from the pump, and flows into the small chamber of the cylinder. This prevents cylinder cavitation by the negative pressure when the pump flow cannot match the bucket dump speed.

5) WHEN THE RCV LEVER IS IN THE ROLL BACK (retract) POSITION

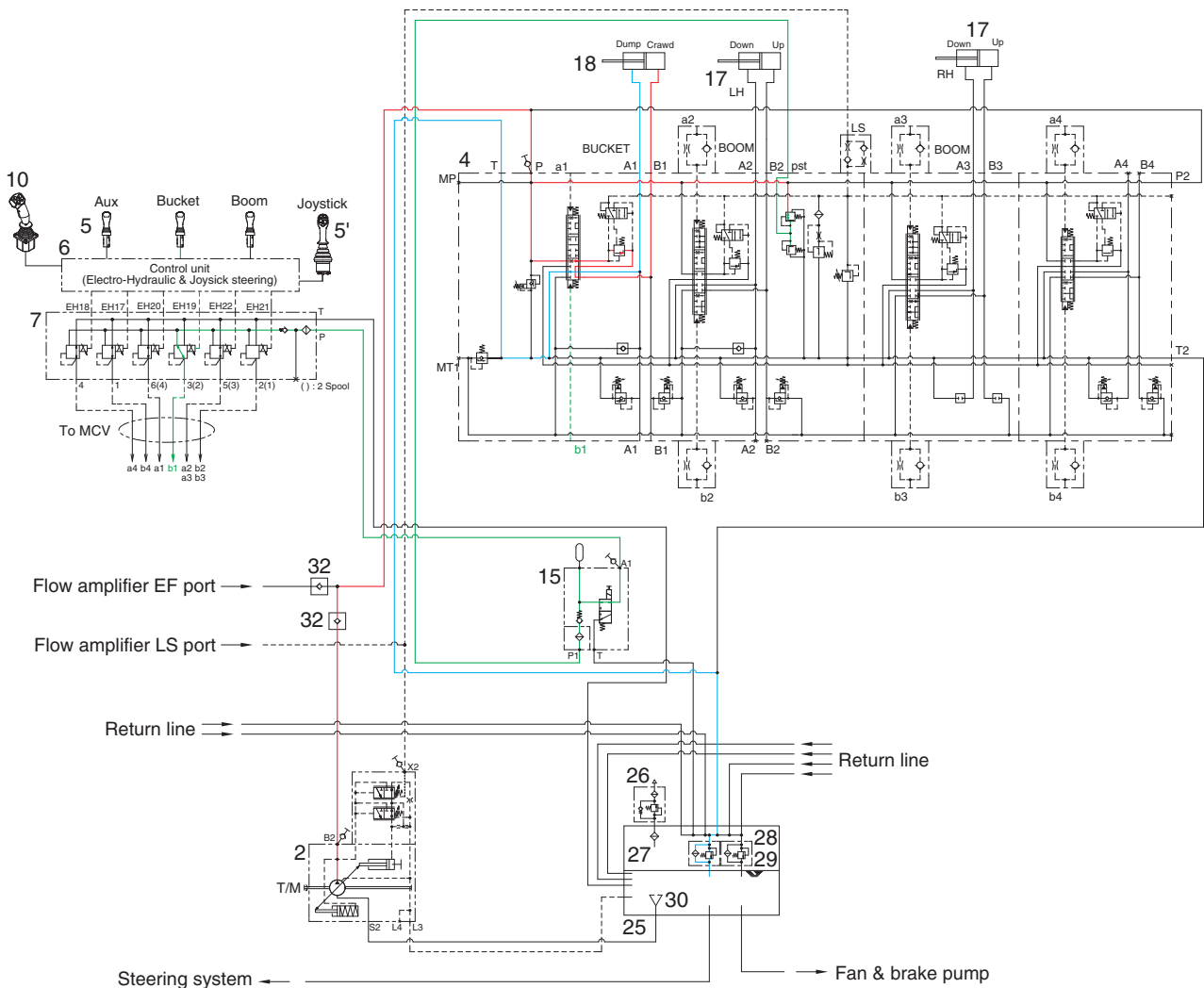

9806WE07

- If the EH RCV lever (5, bucket) is pulled left, the bucket spool is moved to roll back position by pilot oil pressure from EH control block.
- The oil from loader pump (2) flows into main control valve (4) and then goes to the large chamber of bucket cylinder by pushing the load check valve of the bucket spool.
- The oil at the chamber of bucket cylinder (18) returns to hydraulic tank (25).
- When this happens, the bucket roll back.

4. MAIN PUMP (LOADER PUMP)

1) STRUCTURE (1/2)

This loader pump is variable displacement piston pump.

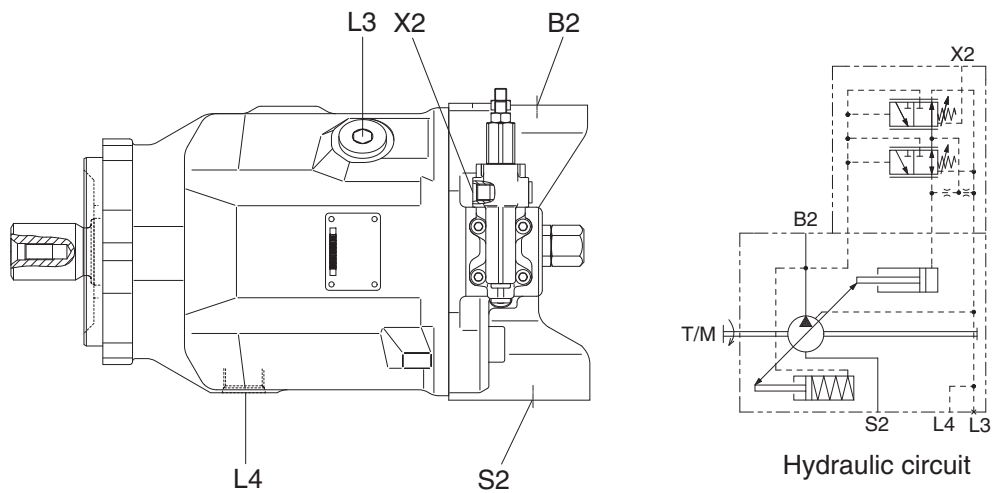

78096WE88

Port	Port name	Port size
B2	Pressure port	SAE 1 1/4"
S2	Suction port	SAE 2 1/2"
L3, L4	Case drain port	1 5/16-12UN
X2	Pilot pressure port	7/16-20UNF

• STRUCTURE (2/2)

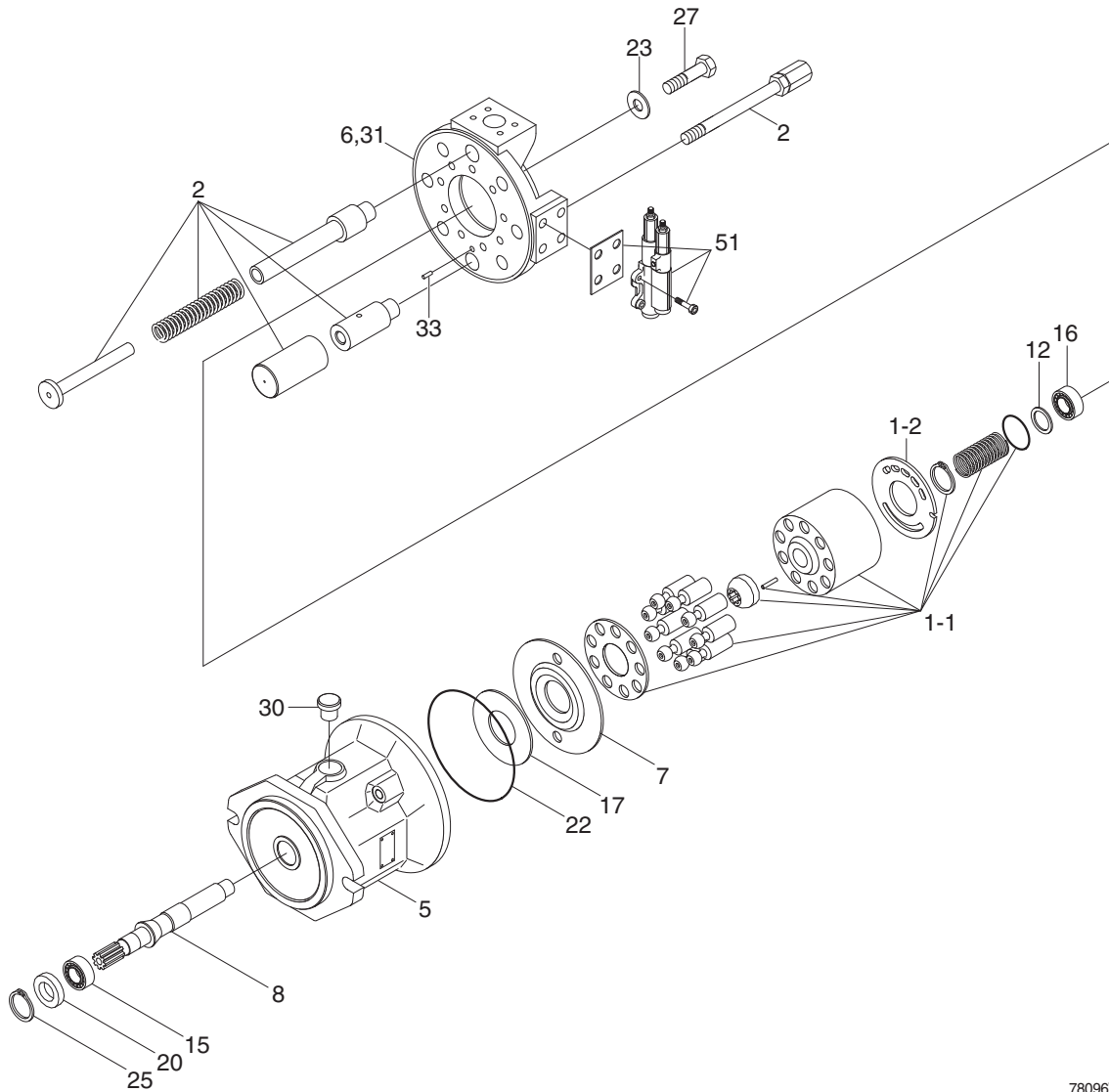

78096WE11

- | | | | | | |
|-----|-------------------------|----|----------------------|----|----------------------|
| 1 | Rotary group | 8 | Drive shaft | 23 | O-ring |
| 1-1 | High speed rotary group | 12 | Adjustment shim | 25 | V-ring |
| 1-2 | Control plate | 15 | Taper roller bearing | 27 | Socket screw |
| 2 | Adjusting piece | 16 | Taper roller bearing | 30 | Locking screw |
| 5 | Pump housing | 17 | Bearing liner | 31 | Double break-off pin |
| 6 | Port plate | 20 | Shaft seal ring | 33 | Cylinder pin |
| 7 | Swash plate | 22 | O-ring | 51 | Control valve |

2) FUNCTION

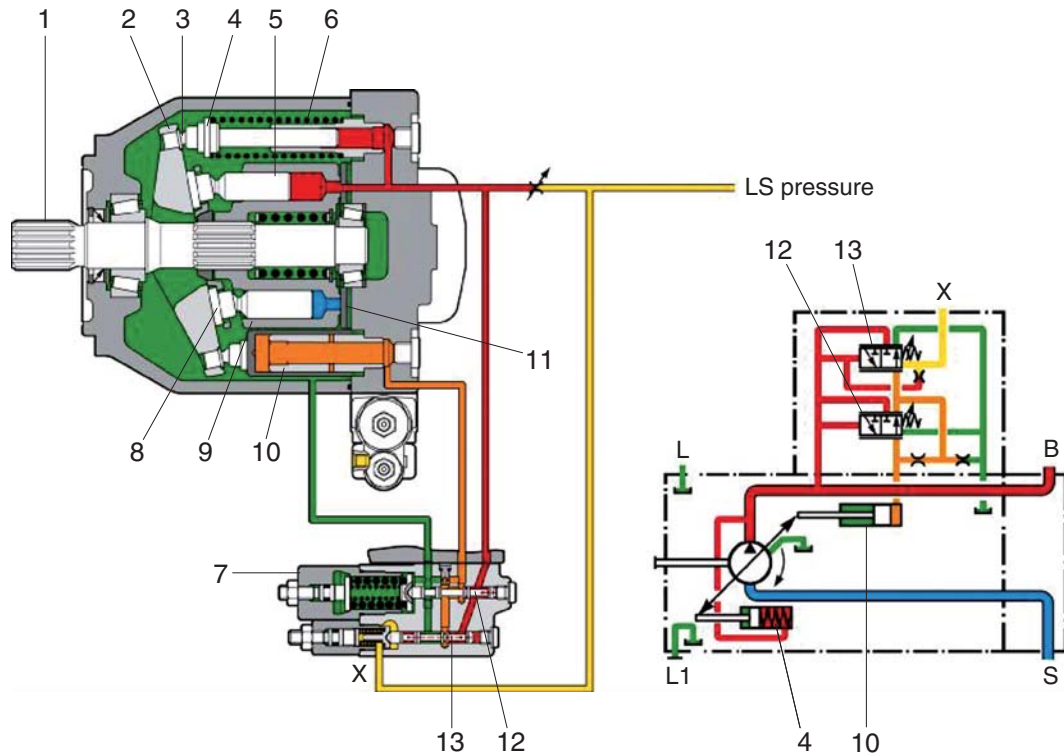

75796WE33

1	Drive shaft	6	Counter spring	11	Control plate
2	Swash plate	7	Pressure & flow compensator valve	12	Pressure compensator spool
3	Shoe plate	8	Piston shoe	13	Flow compensator spool
4	Counter piston	9	Cylinder		
5	Piston	10	Control piston		

The steering pump and loader pump are variable displacement piston pump. The steering pump and loader pump are flow controlled by LS signal. When the steering and loader are not being used, the pumps are at low pressure standby.

The load sensing pressure that is sensed from steering and loader hydraulic systems flows to flow compensator spool (13). This spool keeps the pump output at a level that is necessary to fulfill the requirements for the system flow and for the pressure.

The pressure compensator spool (12) also limits maximum system pressure. The pressure compensator spool (12) prevents damage to the steering and loader hydraulic components from excessive pressure.

The swivel angle of the pumps is controlled by counter piston (4) and control piston (10). Counter spring (6) cause swash plate (2) to move at maximum displacement or causes swash plate (2) to upstroke.

Control piston (10) has a larger area (diameter) than counter piston (4). Control piston (10) causes swash plate (2) to destroke the pump.

Flow compensator spool (13) and/or pressure compensator spool (12) changes pump output by regulating the pump discharge pressure that is acting on control piston (10).

Control piston (10) diameter is larger than counter piston (4) diameter, the oil pressure that is acting against control piston (10) overcomes the force of counter spring (6). The oil pressure then causes the pump to destroke.

Pressure and flow compensator valve (7) also controls the maximum output of pump pressure. When steering and loader pressure rises above pressure compensator setting, pressure compensator spool (12) overrides flow compensator spool (13). This causes the pump to destroke.

(1) Upstroking

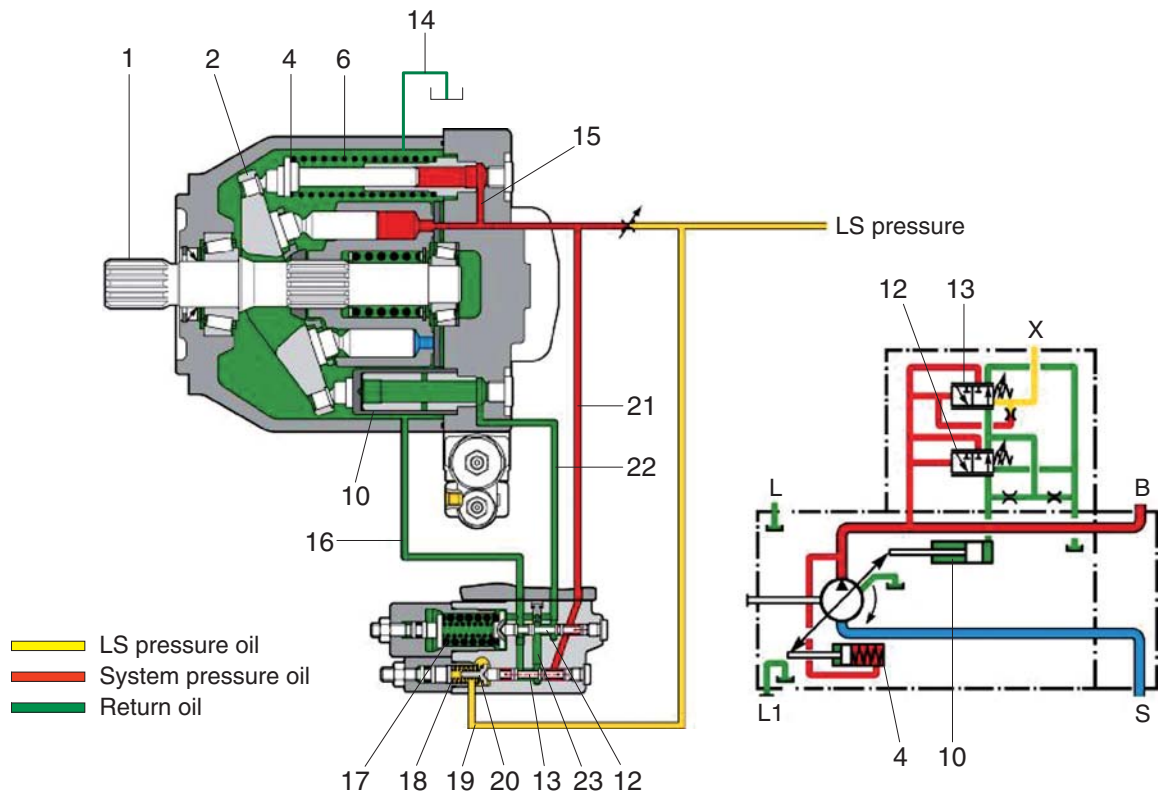

75796WE35

1	Drive shaft	13	Flow compensator spool	19	LS line from the metering pump
2	Swash plate	14	Case drain	20	Cavity
4	Counter piston	15	Passage	21	Passage
6	Counter spring	16	Passage	22	Passage
10	Control piston	17	Spring	23	Cavity
12	Pressure compensator spool	18	Spring		

Upstroking of the pump occurs as flow demand from loader and steering system.

The increased flow demand causes a LS pressure in LS line (19). The LS pressure in LS line (19) combines with the force of spring (18) in cavity (20).

The force of spring (18) causes pump pressure to be higher than the LS pressure (19).

If the combination of LS pressure and of spring force is greater than the pump discharge pressure, this difference pressure causes spool (13) to move right. As spool (13) moves right, the spool (13) blocks the flow of supply oil to control piston (10). Pump swash plate (2) is controlled by pressure and flow as much as hydraulic system requests.

When the oil flow to control piston (10) is blocked, the pilot oil in passage (22) drains to passage (23). The oil then flows past pressure compensator spool (12) and through passage (16) into the housing and via the drain line (14) to tank.

Supply oil flows through passage (15) to counter piston (4). The oil acts against counter piston (4). The oil combines with the force of counter spring (6). This causes swash plate (2) to upstroke.

This also causes the pump flow to increase. As flow requirements are satisfied, the pump output pressure increase. The pressure increases until the pressure in passage (15) moves flow compensator spool (13) up to be satisfied with system requirement for pressure and flow.

- Pump discharge pressure = force of spring (18) + LS pressure (19)

(2) Destroking

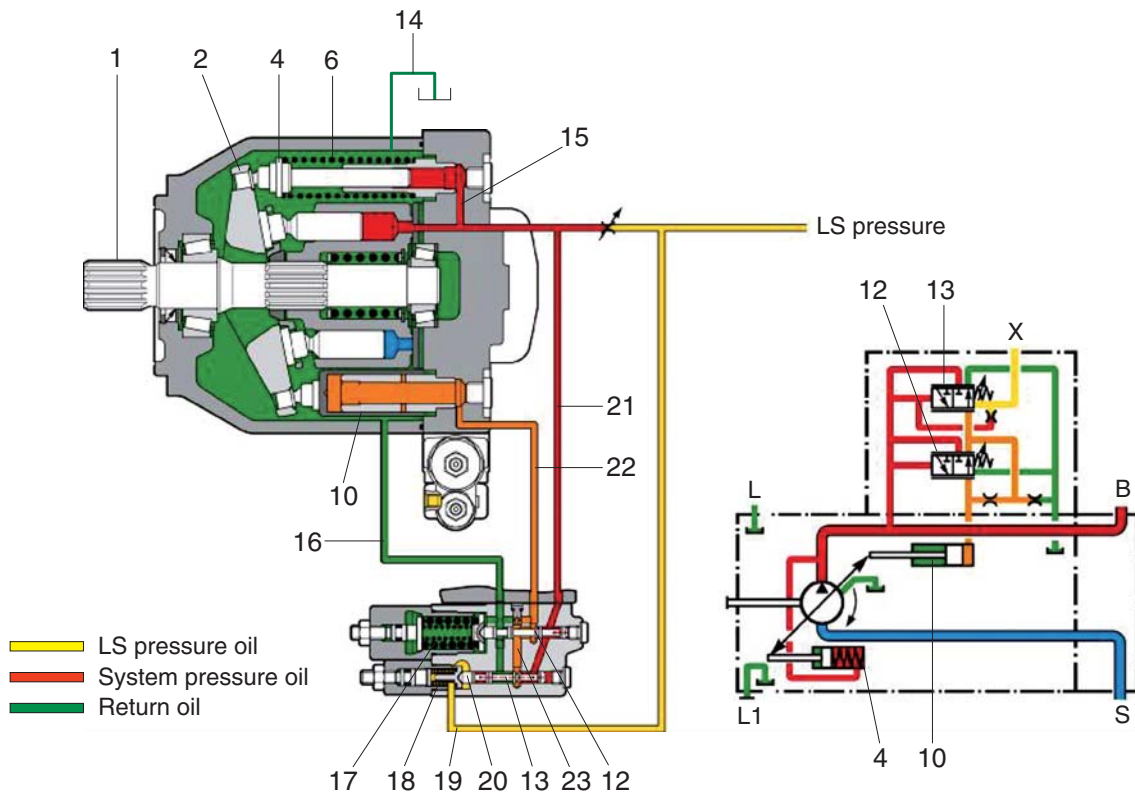

75796WE34

- | | | |
|-------------------------------|---------------------------|-----------------------------------|
| 1 Drive shaft | 13 Flow compensator spool | 19 LS line from the metering pump |
| 2 Swash plate | 14 Case drain | 20 Cavity |
| 4 Counter piston | 15 Passage | 21 Passage |
| 6 Counter spring | 16 Passage | 22 Passage |
| 10 Control piston | 17 Spring | 23 Cavity |
| 12 Pressure compensator spool | 18 Spring | |

The decreased flow demand causes a LS pressure in line (19). The LS pressure in line (19) combines with the force of spring (18) in cavity (20).

This combination of LS pressure and of spring force is less than the pump pressure in passage (21). This causes flow compensator spool (13) to move left.

Pump oil now flows through passage (15). The oil then flows past flow compensator spool (13), through passage (22), and then to control piston (10).

The pump pressure behind control piston (10) is now greater than the combined force of counter piston(4) and of counter spring (6). The angle of swash plate (2) decreases.

This decreases the pump output and the system pressure.

When the lower flow requirements are met, flow compensator spool (13) moves right up to the balanced position. Swash plate (2) maintains an angle that is sufficient to provide the lower required pressure. If the operator does not turn the steering wheel and does not move RCV, then the pump will return to low pressure standby.

※ Control piston → Changes pump displacement ; influenced by controller.

Counter piston → Helps to change pump displacement but no possible to control this piston.

(3) Low pressure standby

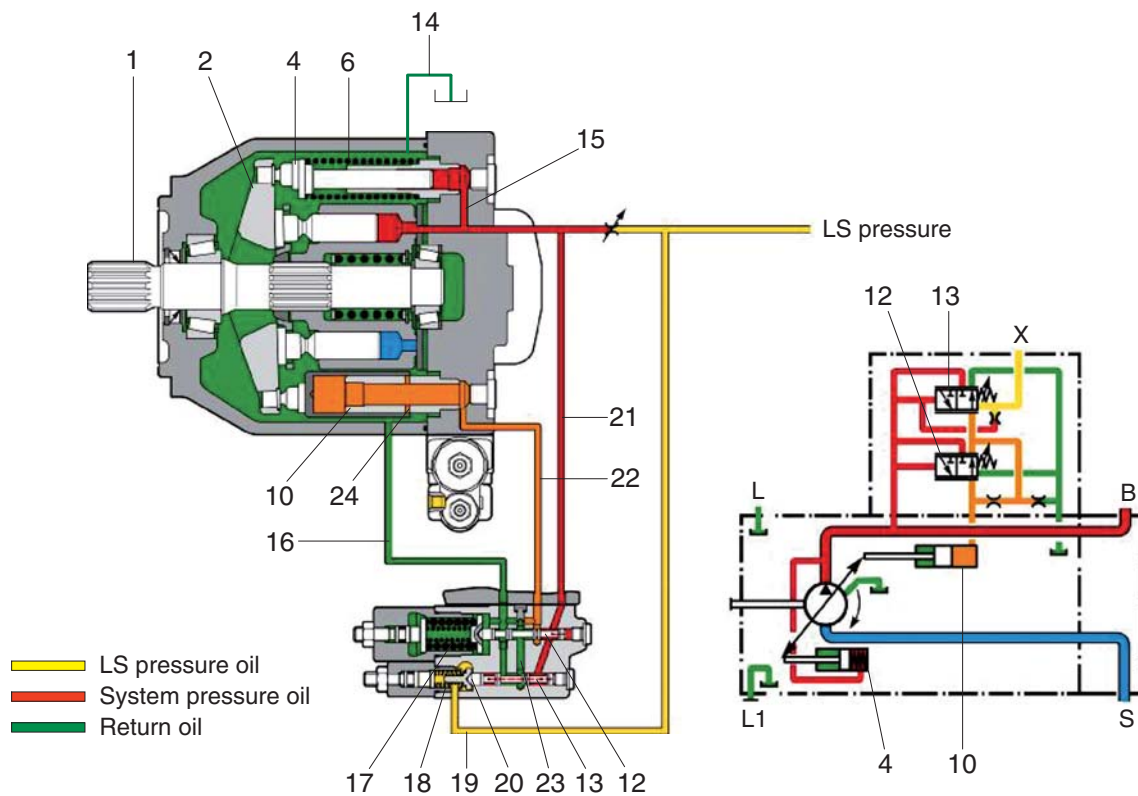

75796WE36

1	Drive shaft	13	Flow compensator spool	19	LS line from the metering pump
2	Swash plate	14	Case drain	20	Cavity
4	Counter piston	15	Passage	21	Passage
6	Counter spring	16	Passage	22	Passage
10	Control piston	17	Spring	23	Cavity
12	Pressure compensator spool	18	Spring	24	Cross-drilled hole

Low pressure standby constitutes the following condition: a running engine and inactive steering and loader. There are no flow demands on the pump or pressure demands on the pump. Therefore, there is no LS pressure in line (19).

Before you start the engine, counter spring (6) holds swash plate (2) at the maximum angle. As the pump begins to turn, oil begins to flow and pressure increases in the system.

Because of close centered steering control valve and close centered loader hydraulic system.

As this pressure increase, the pressure pushes flow compensator spool (13) against spring (18). This causes flow compensator spool (13) to move left. This opens passage (23) in order to allow pressure oil to flow to control piston (10).

The oil acts against control piston (10) in order to overcome the force of counter spring (6). The oil causes control piston (10) to move to the left.

When control piston (10) moves to the left, the piston moves swash plate (2) toward the minimum angle. Control piston (10) continues to move to the left until cross-drilled hole (24) allows the oil to drain to the case.

Cross-drilled hole (24) limits the maximum travel of control piston (10) to the left. The pump supplies a sufficient amount of flow that compensates for system leakage. The pump also supplies a sufficient amount of flow that compensates for leakage to the pump case. The leakage to the pump case is a result of the cross-drilled hole. The pump maintains low pressure standby. Low pressure standby pressure should not exceed 40 bar (580 psi).

- ※ Low pressure standby will vary in the same pump as the system leakage or the pump leakage increases. The pump will upstroke slightly in order to compensate for the increasing leakage. Control piston (10) will cover more of the cross-drilled hole.

(4) High pressure stall

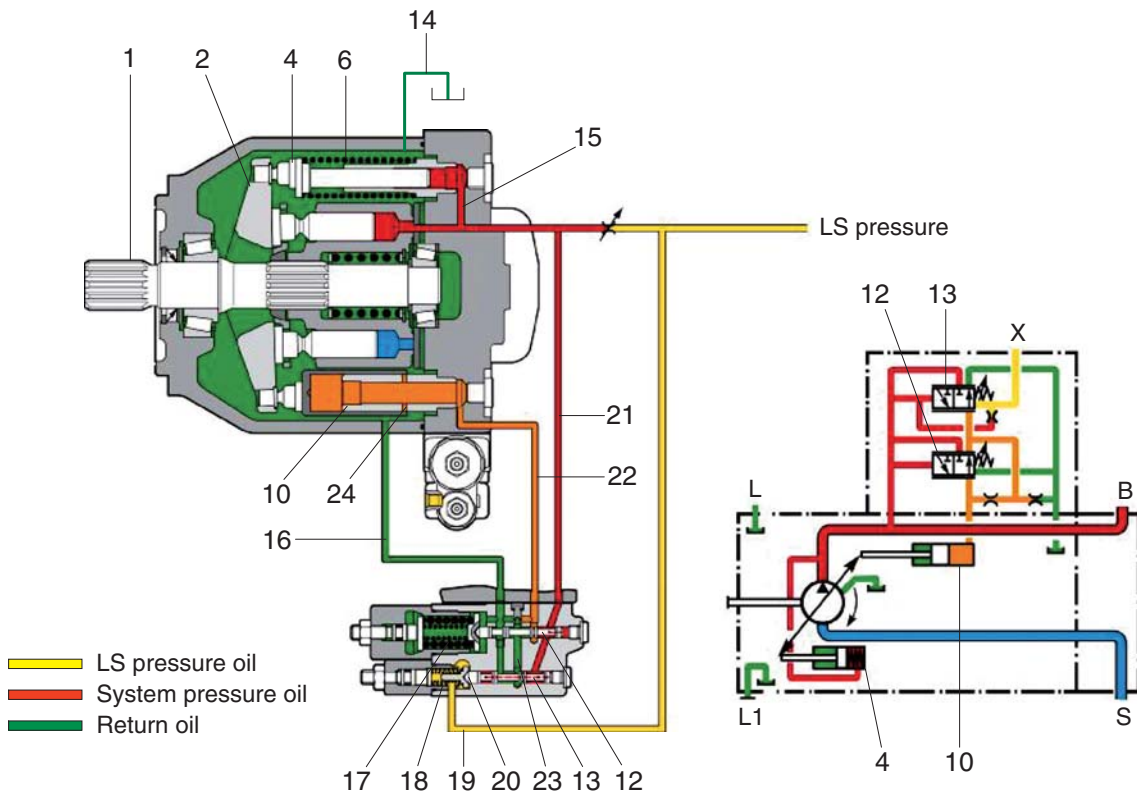

75796WE36

- | | | |
|-------------------------------|---------------------------|-----------------------------------|
| 1 Drive shaft | 13 Flow compensator spool | 19 LS line from the metering pump |
| 2 Swash plate | 14 Case drain | 20 Cavity |
| 4 Counter piston | 15 Passage | 21 Passage |
| 6 Counter spring | 16 Passage | 22 Passage |
| 10 Control piston | 17 Spring | 23 Cavity |
| 12 Pressure compensator spool | 18 Spring | |

When the hydraulic system stalls under load or when the cylinders reach the end of the stroke, the main system pressure increases. But LS pressure (19) is regulated by LS relief valve on steering system and loader system. The pressure difference between discharged pump and LS pressure equal to spring (18). It means no flow is necessary. Therefore, discharged pressure push flow compensator spool (13) left. Supply oil now flows past flow compensator spool (13) and through passage (23). The oil flows past flow compensator spool (13) and into passage (22). The oil then flows to control piston (10).

Pump swash plate (2) will be minimum displacement if the operator does not turn the steering wheel and RCV, then the pump will return to low pressure standby.

(5) Adjustment of flow control

Flow compensator setting must be carried out following procedures and conditions.

① Conditions

- Engine is running (at high or low idle).
- RCV is operated slowly (example : Boom up).
- Pressure gauges are installed.
- ※ Discharge pump flow should be less than max pump flow.

② Procedures

- Loosening the hexagon nut (2).
- Adjusting screw (1) of flow controller by tightening or loosening the screw (1).
 - Flow setting : $\Delta P = \text{Gauge A} - \text{Gauge B}$
 - Specification : Steering pump (27 bar)/Loader pump (22 bar)

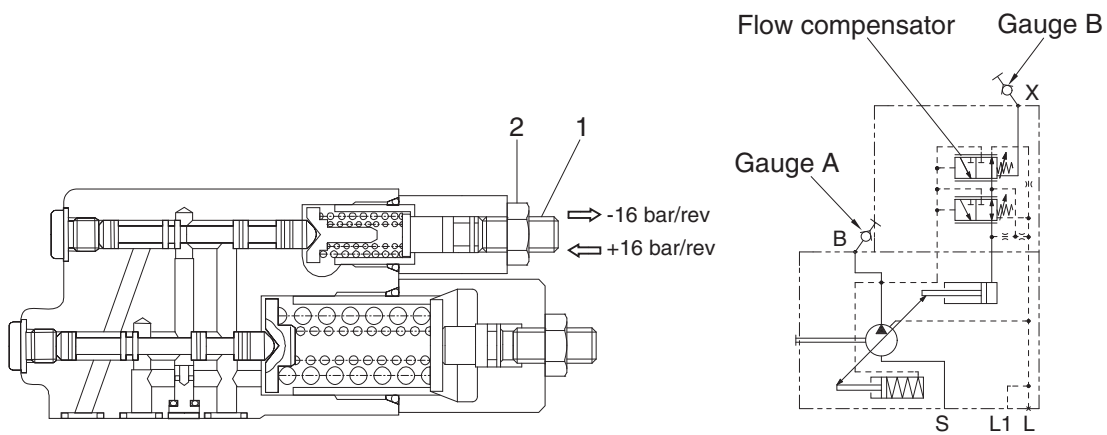

75796WE37

(6) Adjustment of pressure control

Pressure compensator setting must be carried out following procedures and conditions.

① Conditions

- Engine is running.
- System is at relief condition.

② Procedures

- Loosening the hexagon nut (2).
- Adjusting screw (1) of pressure controller by tightening or loosening the screw (1).
 - Maximum pressure setting = Gauge A
 - Specification : Steering pump (250 bar)/Loader pump (300 bar)

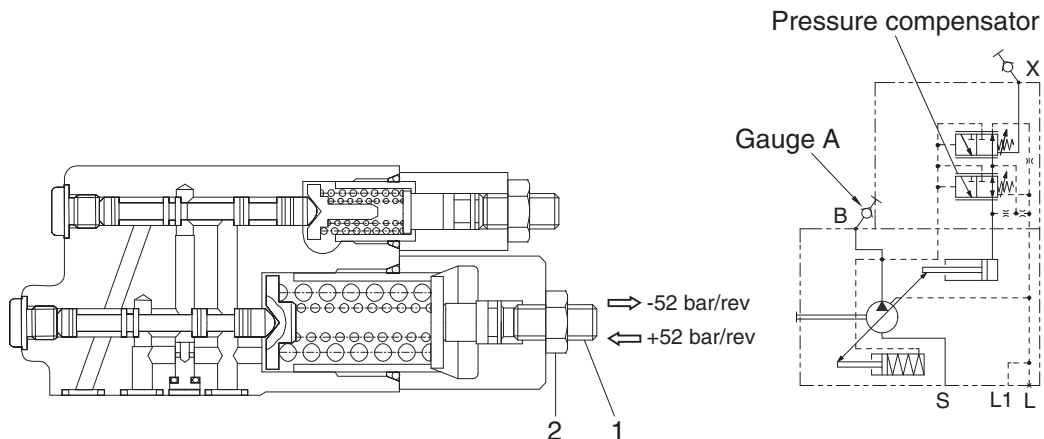

75796WE38

5. EH (electro hydraulic) CONTROL BLOCK

1) STRUCTURE

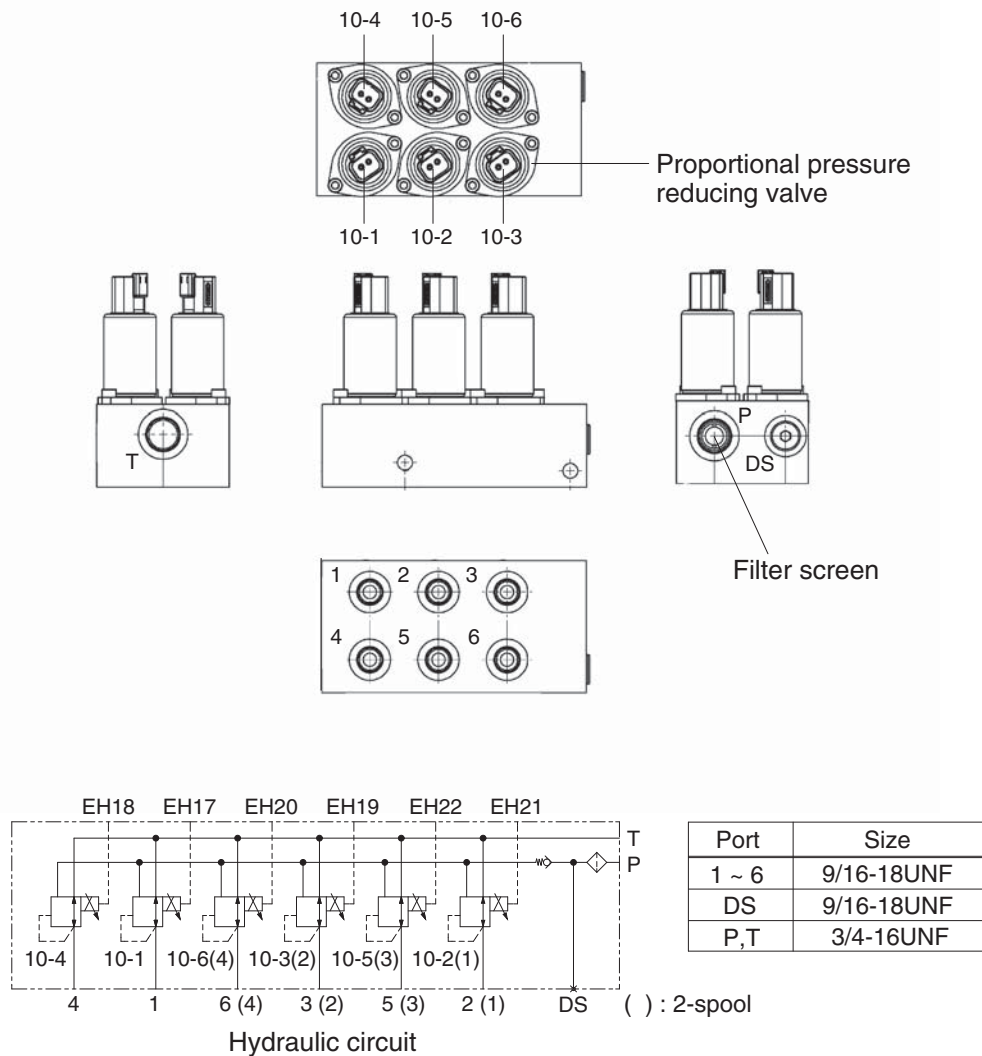

760F6WE33

2) OPERATION

The proportional pressure reducing valve (10-1~6) is a direct-acting spool-type valve. When de-energized, port 2 is closed and port 1 (delivery) is connected to port 3 (tank). When the inlet pressure fluctuates it provides an almost constant outlet pressure—depending on the energization of the coil. When the control current increases, the coil solenoid exerts a force on the control piston which is proportional to the control current and thereby defines the regulated pressure at port 1. This setting is proportional to the control current. Pressures at tank port 3 are additive to the set pressure. If, as a result of external factors, the pressure at port 1 rises above the preset pressure, the valve opens from port 1 to tank port 3.

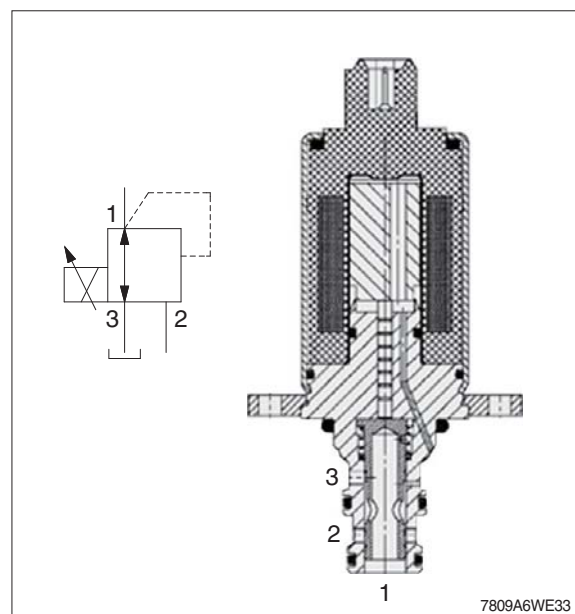

6. MAIN CONTROL VALVE

1) STRUCTURE (1/3)

- Type : Closed center, Load pressure - Independent - Flow - Distribution

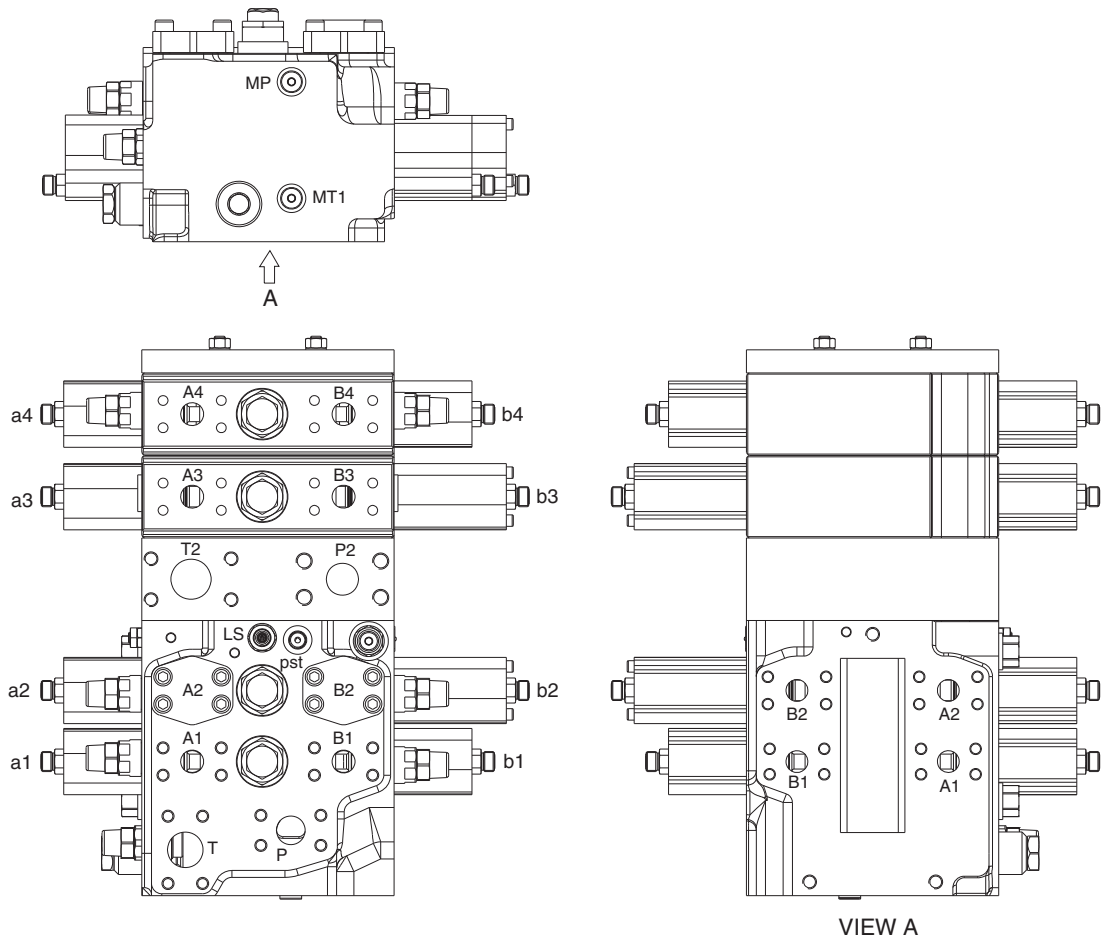

VIEW A

Hydraulic circuit

98096WE10

Port	Port name	Port size	Port	Port name	Port size
P	From main pump	SAE 1"	a2, b2	Boom pilot port	11/16-16UN
T	To hydraulic tank	SAE 1 1/4"	a3, b3	Auxiliary pilot port	11/16-16UN
A1, B1	To bucket cylinder port	SAE 3/4"	LS	Load sensing port	9/16-18UNF
A2, B2, A3, B3	To boom cylinder port	SAE 3/4"	Pst	To RCV P port	9/16-18UNF
a1, b1	Bucket pilot port	11/16-16UN	-	-	-

STRUCTURE (2/3)

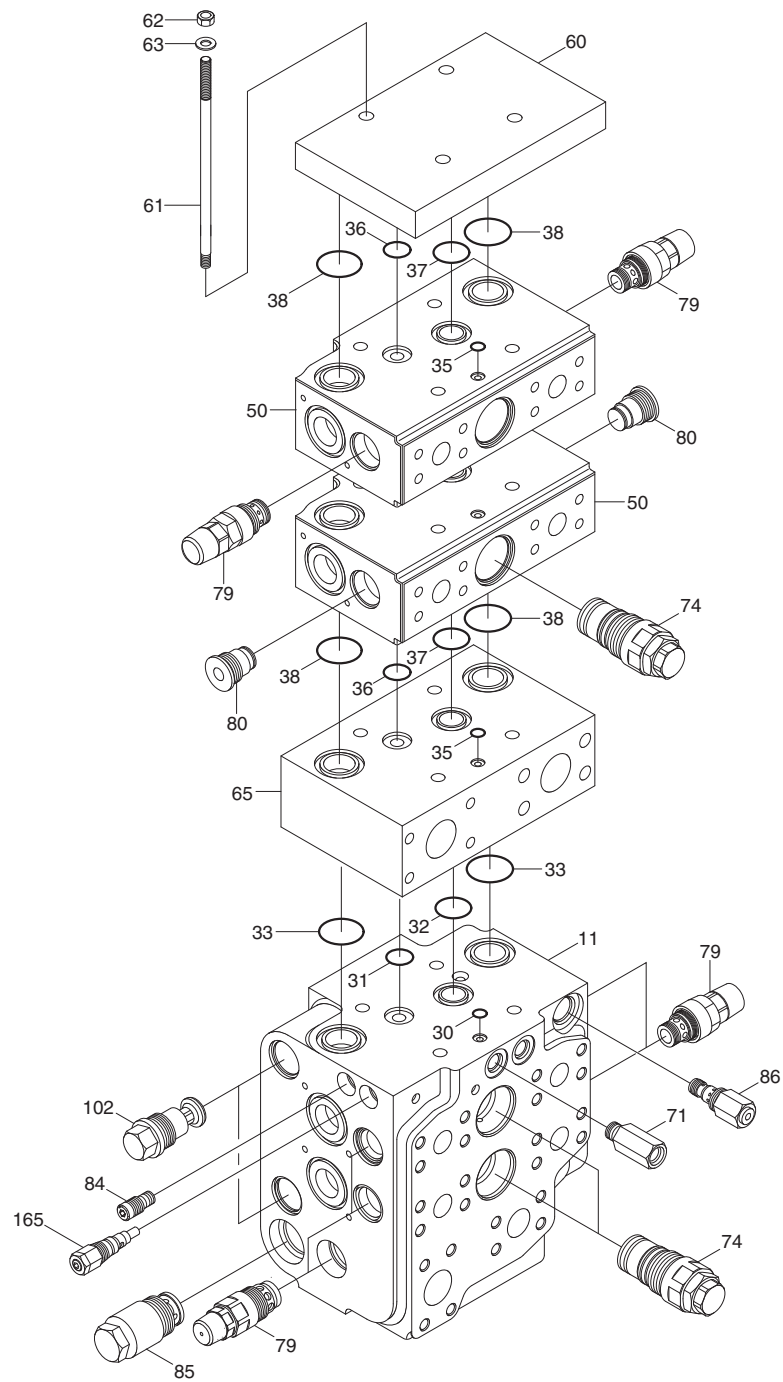

78096WE13

11	Housing	38	O-ring	74	Compensator valve
30	O-ring	50	Housing	79	Pressure valve
31	O-ring	60	Plate	80	Plug screw
32	O-ring	61	Stud	84	Flow regulator
33	O-ring	62	Hexagon nut	85	Precharge valve
35	O-ring	63	Washer	86	Pressure reducing valve
36	O-ring	65	Sandwich plate	102	Locking screw
37	O-ring	71	Shuttle valve	165	Pressure relief valve

STRUCTURE (3/3)

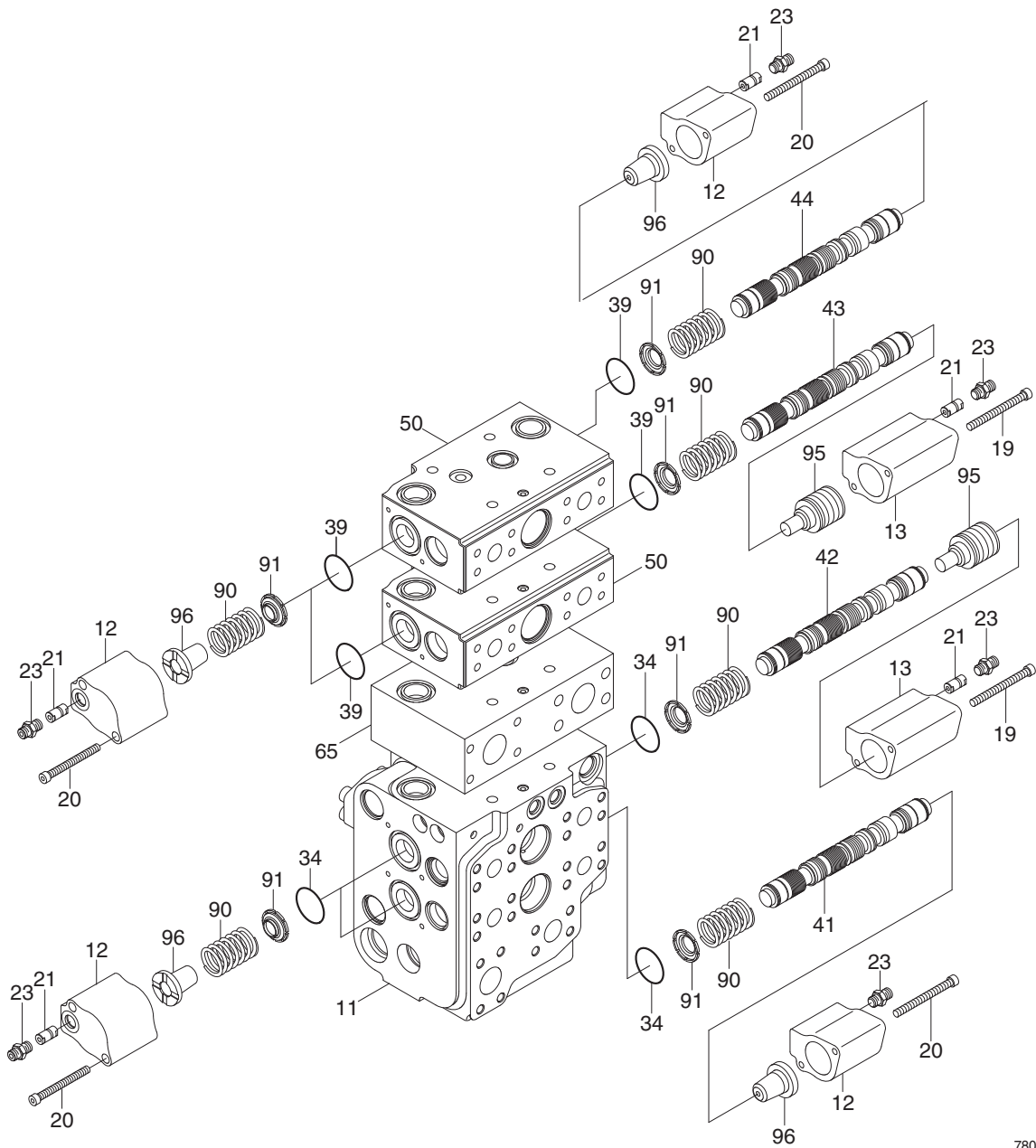

78096WE14

- | | | | | | |
|----|-----------------------------|----|---------|----|--------------------|
| 11 | Housing | 34 | O-ring | 65 | Sandwich plate |
| 12 | Cover | 39 | O-ring | 90 | Compression spring |
| 13 | Cover | 41 | Spool | 91 | Spring retainer |
| 19 | Bolt | 42 | Spool | 95 | Spring retainer |
| 20 | Bolt | 43 | Spool | 96 | Spring retainer |
| 21 | Throttle check valve | 44 | Spool | | |
| 23 | Threaded steel pipe fitting | 50 | Housing | | |

2) FUNCTION

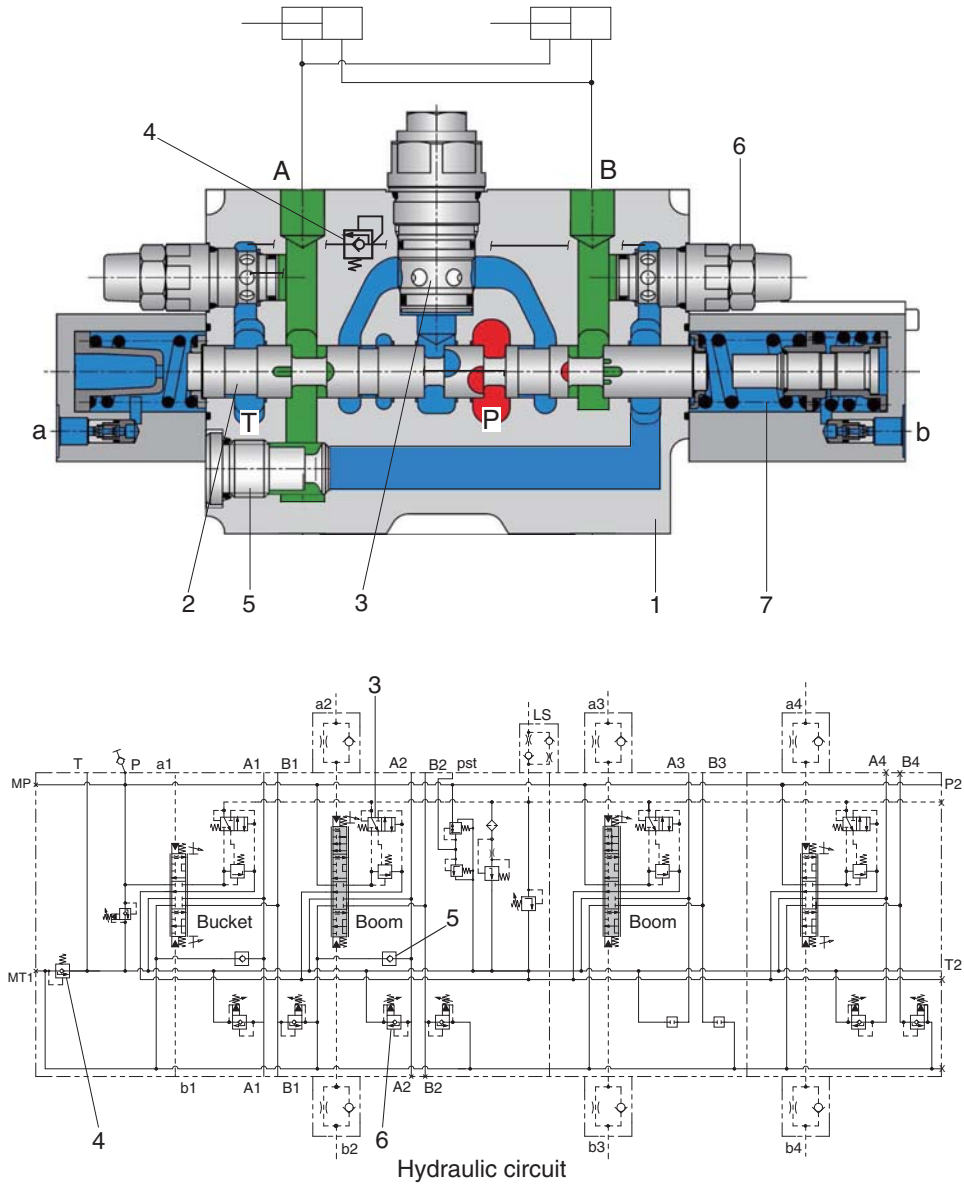

- | | | | | | |
|---|----------------------|---|--------------------------|---|----------------|
| 1 | Housing | 4 | Counter balance valve | 7 | Spring chamber |
| 2 | Spool | 5 | Regeneration check valve | | |
| 3 | Pressure compensator | 6 | Port relief valve | | |

98096WE15

(1) Control block

Proportional direction valve to the LUDV principle (Load pressure - Independent - Flow - Distribution)

(2) Actuator control

At the spool (2) the direction and volume of flow is determined that flows to the actuator connections (A or B).

The spring chambers (7) are supplied with pilot pressure either via the pilot connections a and b hydraulic control.

The value of the pilot pressure within the spring chamber (7) determines the stroke of the spool (2).

The pressure compensator (3) controls the pressure differential at the spool (2) and therefore, the flow to the actuators (A, B).

(3) Loader pressure compensation (LUDV)

The control block works to the LUDV principle. In this load - sensing version the pressure compensators (3) are located between the spool (2) and the actuator connections (A, B).

The highest load pressure of all of the actuators involved is applied to all of the pressure compensators. In parallel it is also applied to the pump.

If the pump flow is insufficient for all of the functions, then all work movements are reduced in speed by the same ratio.

(4) Pressure safety, actuator connections

Large nominal size port relief valve (6) with combined anti-cavitation functions protect the actuators from overloads and cavitation.

(5) Float position

The float position is obtained by means of a 4-position spool.

(6) Regeneration

To prevent cavitation, with negative loads (e. g. dump or lowering), the tank port is pre-loaded via counter balance valve (4) and is fed with oil via the regeneration check valve (5) downstream of the pressure compensator.

3) BOOM SECTION OPERATION

(1) Spool in neutral

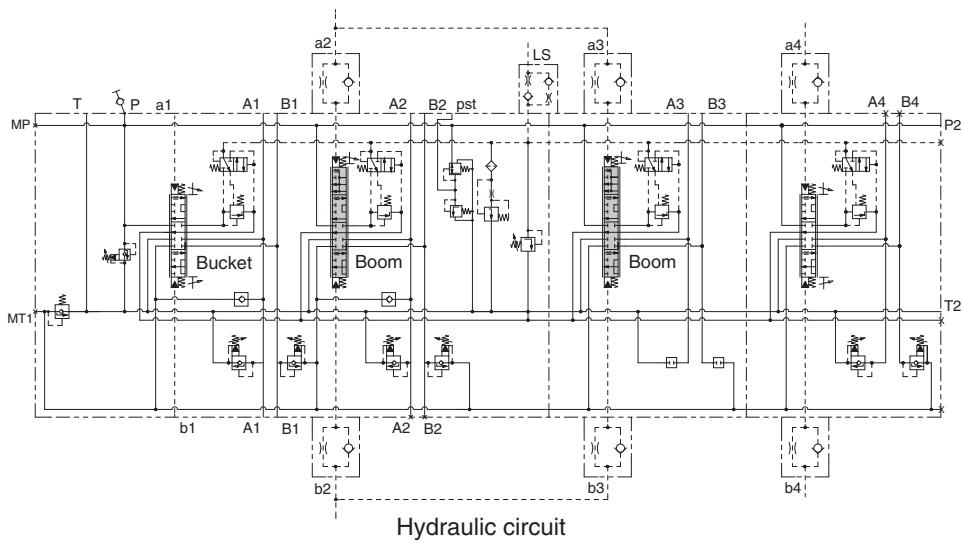
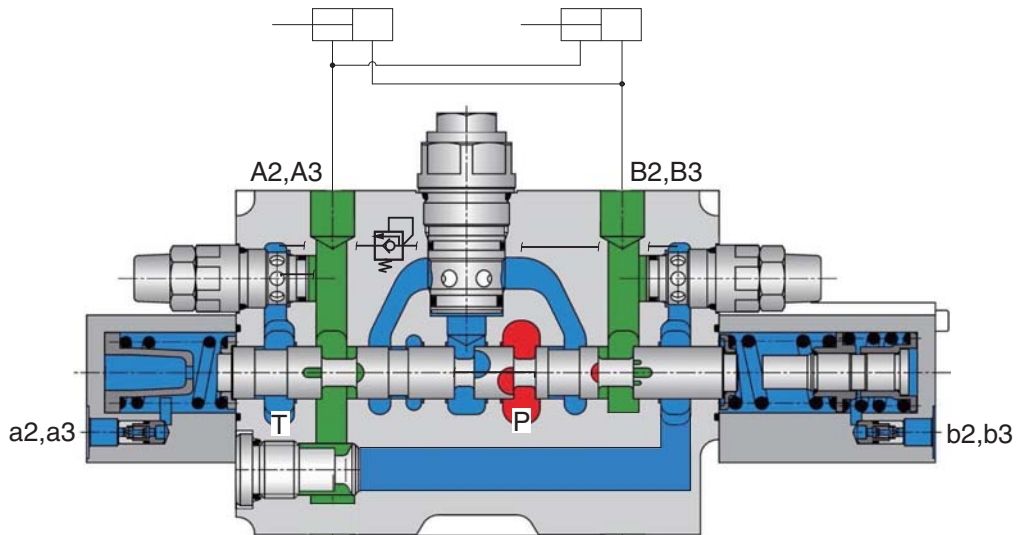

98096WE51

When the boom spool is in neutral position, oil from the pump will be blocked.
Then, the pumps are at low pressure stand by.

(2) Boom raise position

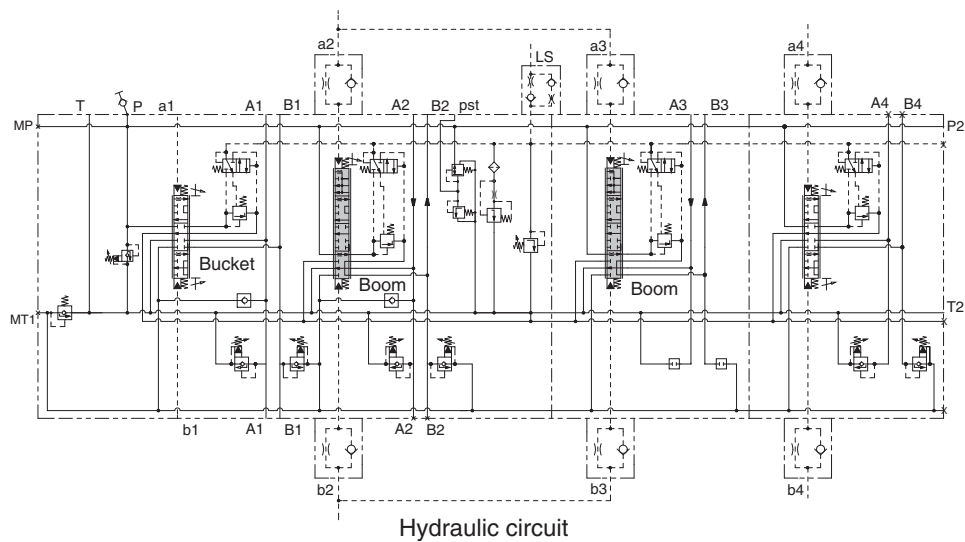
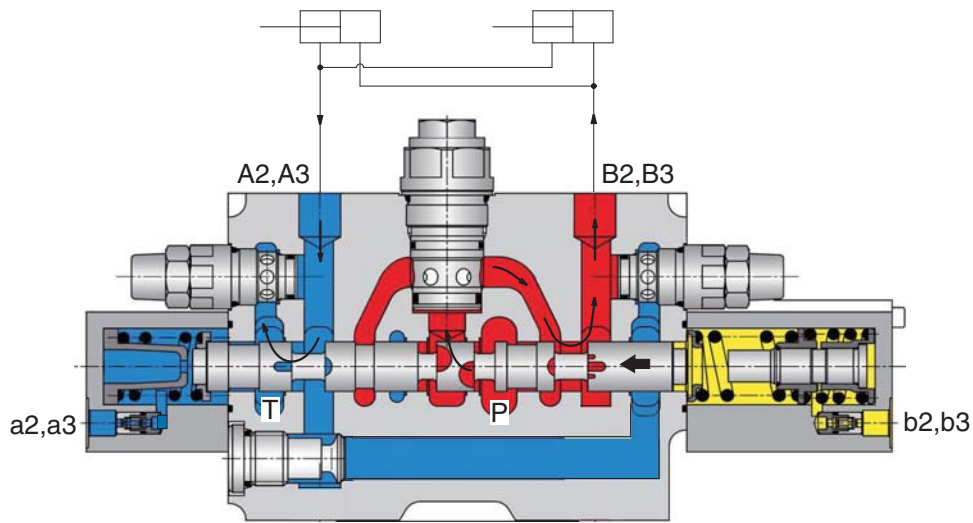

98096WE52

When the pilot pressure is led to the port b2, b3 the boom spool moved to raise position. Oil from the pump flows to the cylinder port B2, B3 and oil from the cylinder flows into the tank passage through the cylinder port A2, A3.

(3) Boom lower position

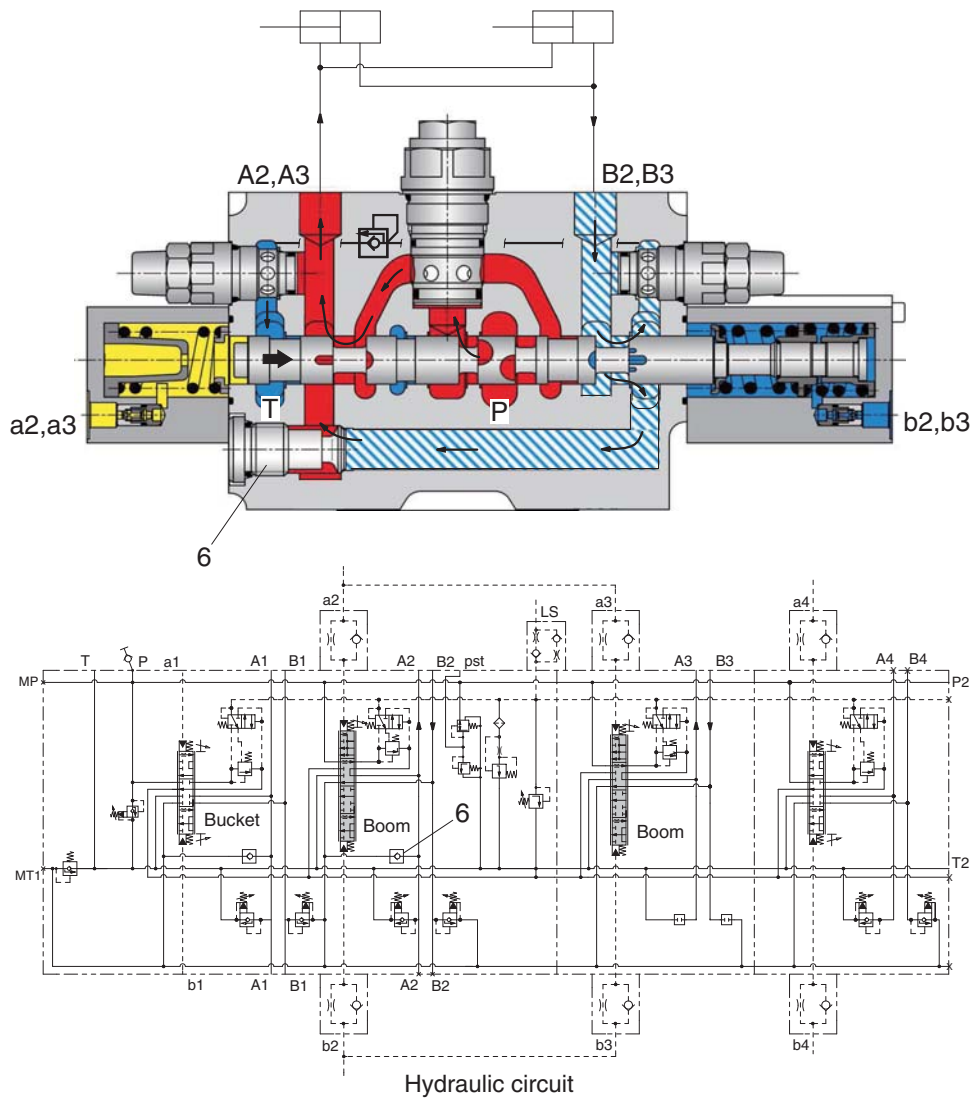

98096WE53

When the pilot pressure is led to the port a2, a3, the boom spool moved to lower position. Oil from the pump flows to the cylinder port A2, A3 and oil from the cylinder flows into the tank passage through the cylinder port B2, B3. When the lowering speed of boom is faster, the return oil from the large chamber of boom cylinder combines with the oil from the pump through regeneration check valve (6), and flows into the small chamber of the cylinder. This prevents cylinder cavitation by the negative pressure when the pump flow cannot match the boom down speed.

(4) Boom float position

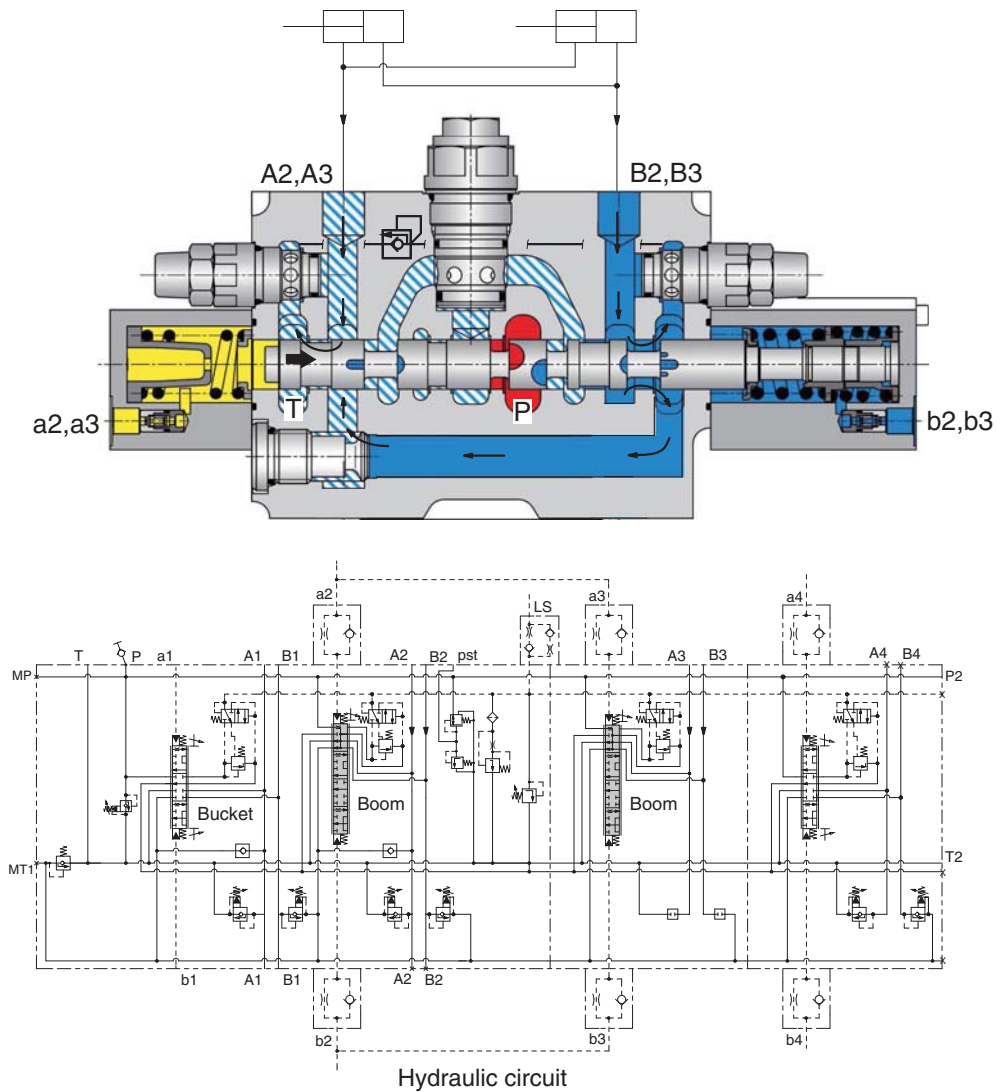

98096WE54

When the boom spool is located in float position, the oil from the pump will be blocked. The cylinder ports (A2, A3, B2, B3) are connected to the tank passage, so the boom will be lowered due to its own weight.

4) BUCKET SECTION OPERATION

(1) Spool in neutral

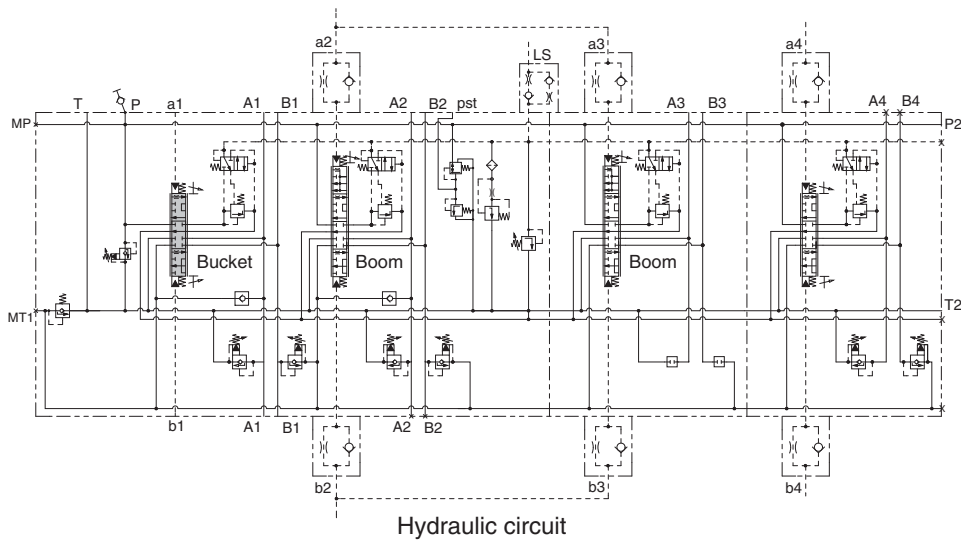
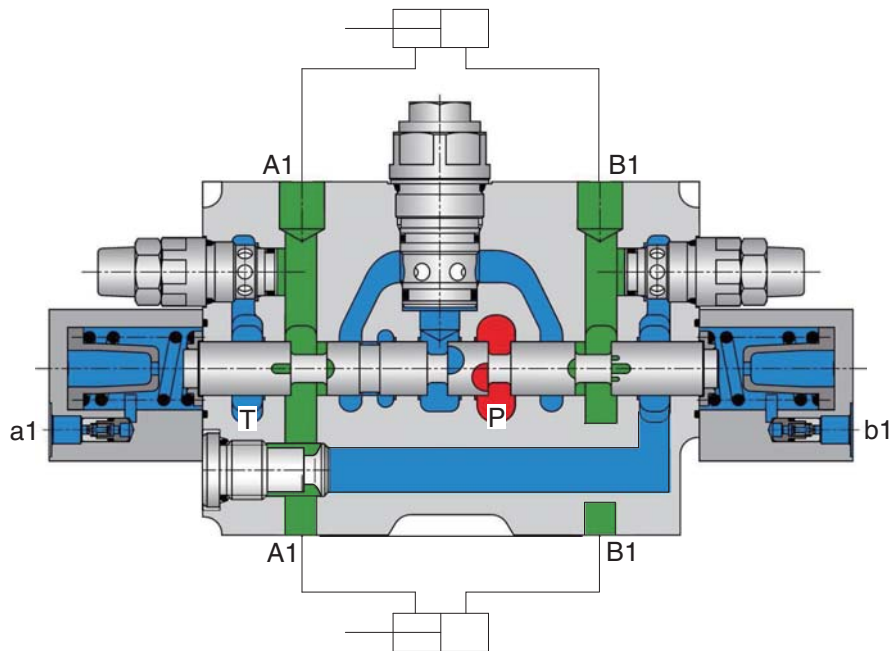

98096WE55

When the bucket spool is in neutral position, oil from the pump will be blocked.
Then, the pumps are at low pressure standby.

(2) Bucket rollback position

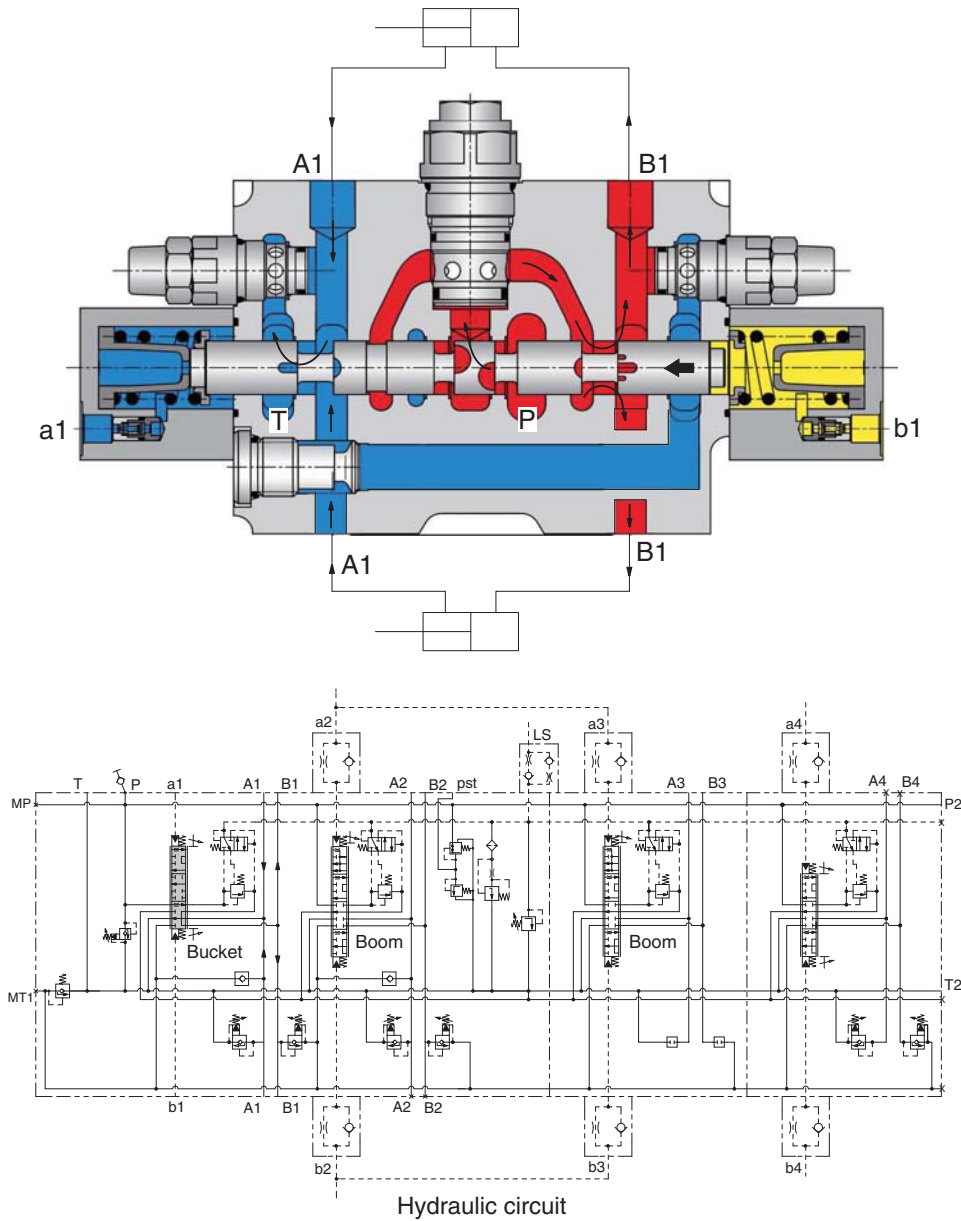

98096WE56

When the pilot pressure is led to the port b1, the bucket spool moved to rollback position. Oil from the pump flows to the cylinder port B1 and oil from the cylinder flows into the tank passage through the cylinder port A1.

(3) Bucket dump

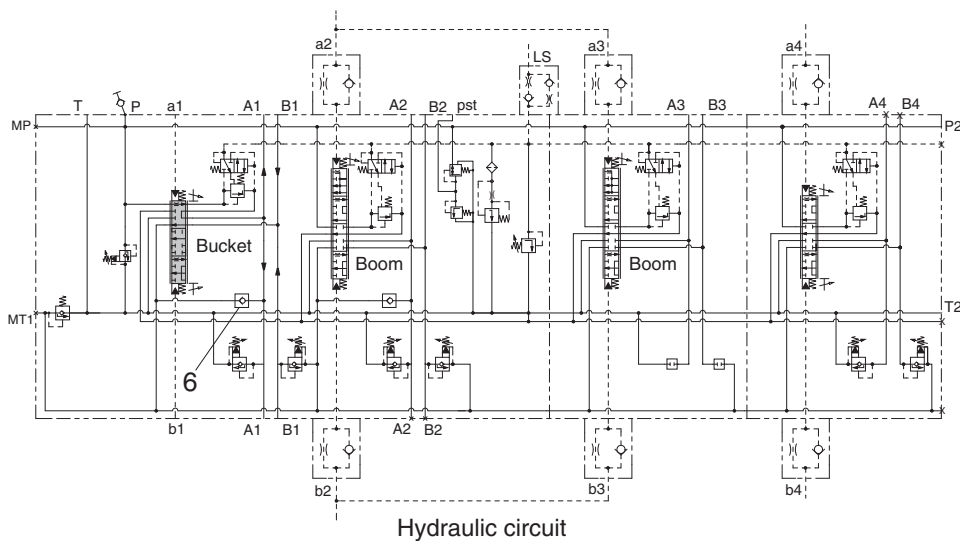
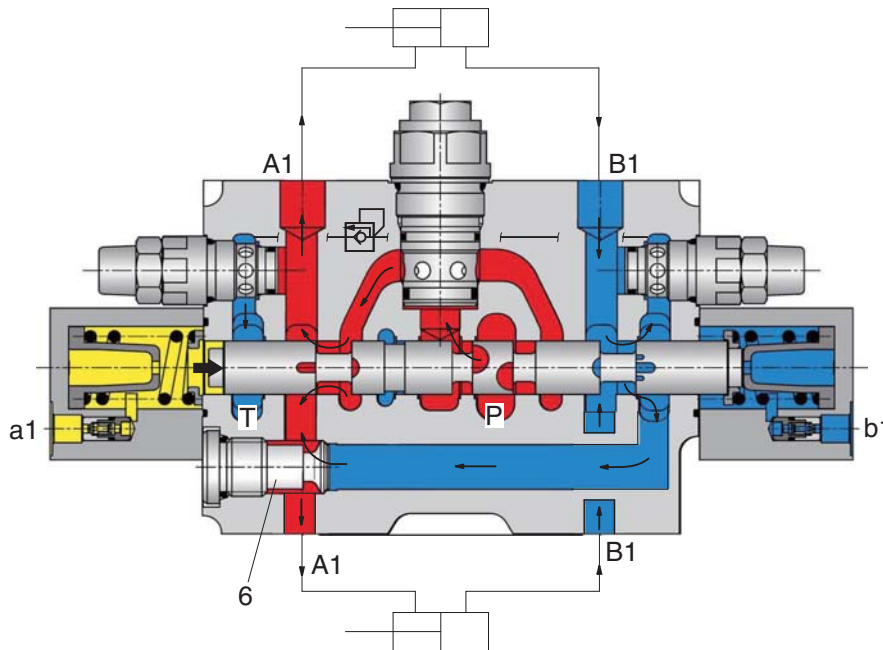

98096WE57

When the pilot pressure is led to the port a1, the bucket spool moved to dump position. Oil from the pump flows to the cylinder port A1, through the load holding valve and oil from the cylinder flows into the tank passage through the cylinder port B1. When the dumping speed of bucket is faster, the return oil from the large chamber of bucket cylinder combines with the oil from the pump through regeneration check valve (6), and flows into the small chamber of the cylinder. This prevents cylinder cavitation by the negative pressure when the pump flow cannot match the bucket dump speed.

7. SAFETY VALVE

1) STRUCTURE

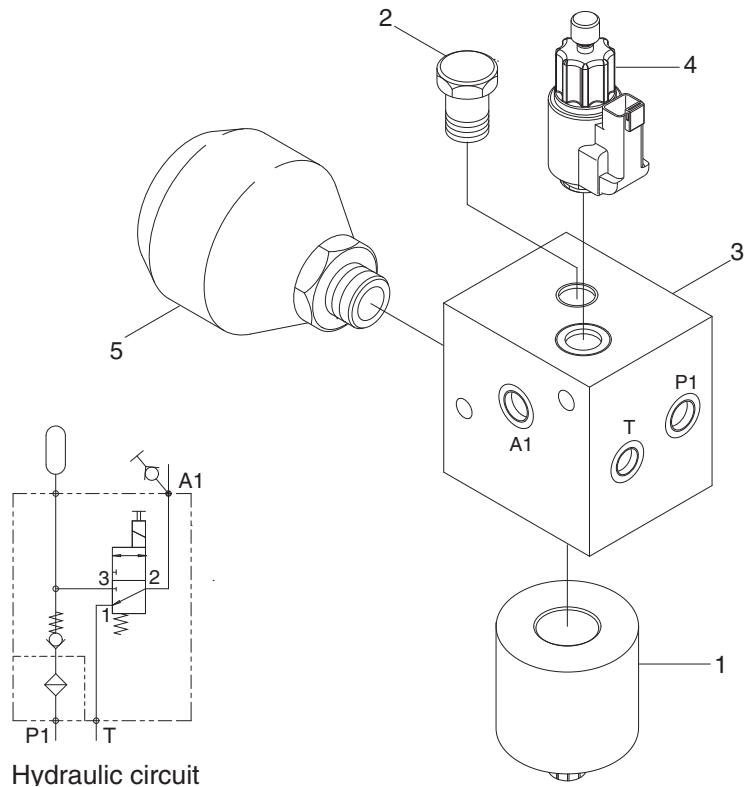

Port	Port name	Port size
P1	From MCU	PF 3/8"
A1	Supply to RCV lever	PF 1/4"
T	To hydraulic tank	PF 1/4"

75796WE16

- | | | | |
|---|-----------------------|---|----------------|
| 1 | Bowl and element assy | 4 | Solenoid valve |
| 2 | Check valve | 5 | Accumulator |
| 3 | Cartridge | | |

2) OPERATION

This valve is used to cut off the pilot circuit.

When the pilot cut off switch in the cab is pressed to ON position, the solenoid valve is activated and then the pilot oil flow into the pilot circuit.

The accumulator satisfied short term peak power demands and is a source of emergency power in case of main circuit pressure failures.

8. BOOM AND BUCKET CYLINDER

The boom cylinders are two unit and the bucket cylinder is one unit. They use a bolt on rod guide.

The piston (14) threads on to the rod (2) and is retained by a nut (20) and set screw (21).

The piston seals against the tube (1) with piston seal (15). Two wear rings (16) are located on each side of the piston seal.

The gland (3, the rod guide) seals against the tube with an O-ring (12). The cylinder thread seals against the rod with a lip type buffer ring (8) and a rod seal (5). A dust wiper (9) cleans the rod when it is retracted.

1) BOOM CYLINDER

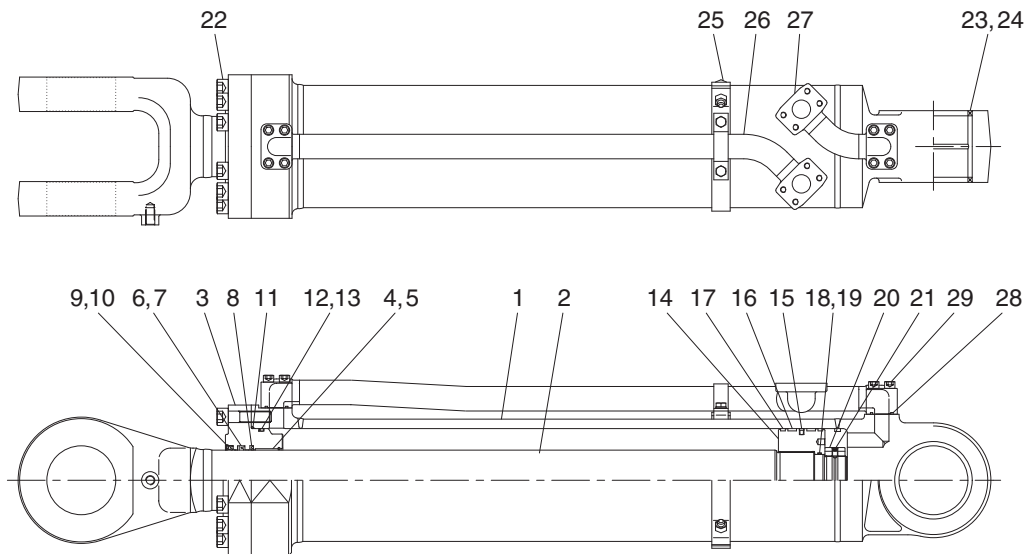

78096WE17

1	Tube assembly	11	O-ring	21	Set screw
2	Rod assembly	12	O-ring	22	Bolt
3	Gland	13	Back up ring	23	Bushing
4	Bushing	14	Piston	24	Dust seal
5	Snap ring	15	Piston seal	25	Band
6	Rod seal	16	Wear ring	26	Pipe assembly
7	Back up ring	17	Dust ring	27	Pipe assembly
8	Buffer ring	18	O-ring	28	O-ring
9	Dust wiper	19	Back up ring	29	Bolt
10	Snap ring	20	Lock nut		

2) BUCKET CYLINDER

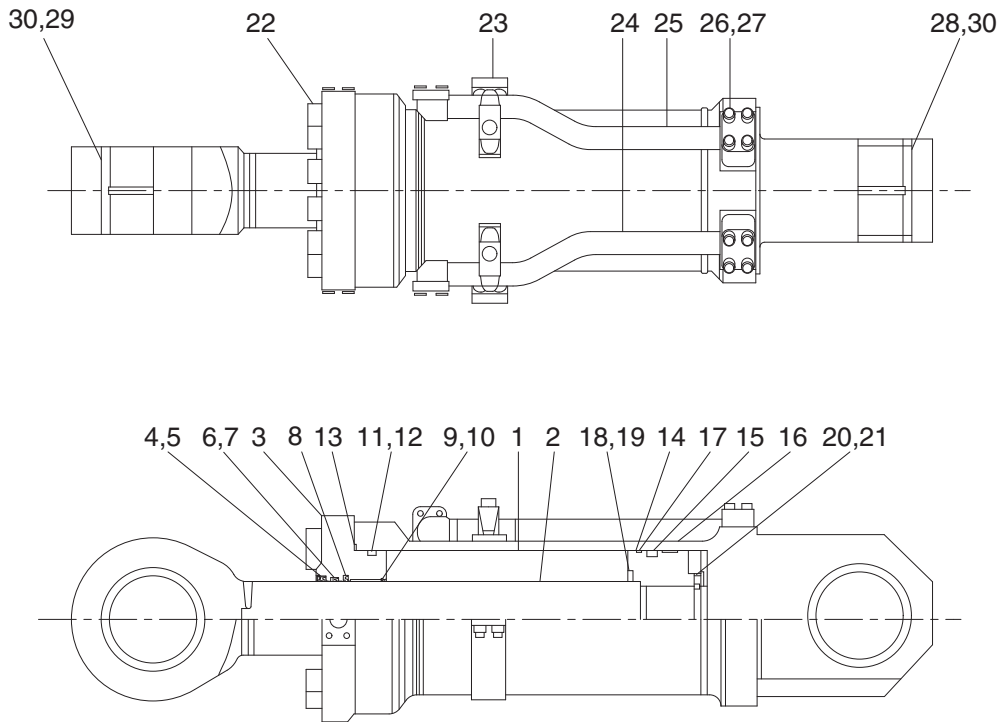

9806WE18

1	Tube assembly	11	O-ring	21	Set screw
2	Rod assembly	12	Back up ring	22	Bolt
3	Gland	13	O-ring	23	Band assembly
4	Dust wiper	14	Piston	24	Pipe assembly
5	Snap ring	15	Piston seal	25	Pipe assembly
6	Rod seal	16	Wear ring	26	Bolt
7	Back up ring	17	Dust ring	27	O-ring
8	Buffer ring	18	O-ring	28	Pin bushing
9	Bushing	19	Back up ring	29	Pin bushing
10	Snap ring	20	Steel ball	30	Dust seal

9. HYDRAULIC OIL TANK

1) STRUCTURE

- The oil from the hydraulic tank is sent from the pump through main control valve to the cylinders. In the return circuit, the oil from various parts merges.
- A part of oil is cooled in the oil cooler, passes through the hydraulic filter and returns to the hydraulic tank (1).
- If the hydraulic return oil filter becomes clogged, return filter bypass valve (16) acts to allow the oil to return directly to the hydraulic tank (1). This prevents damage to the hydraulic filter (14). The bypass valve (16) is also actuated when negative pressure is generated in the circuit.

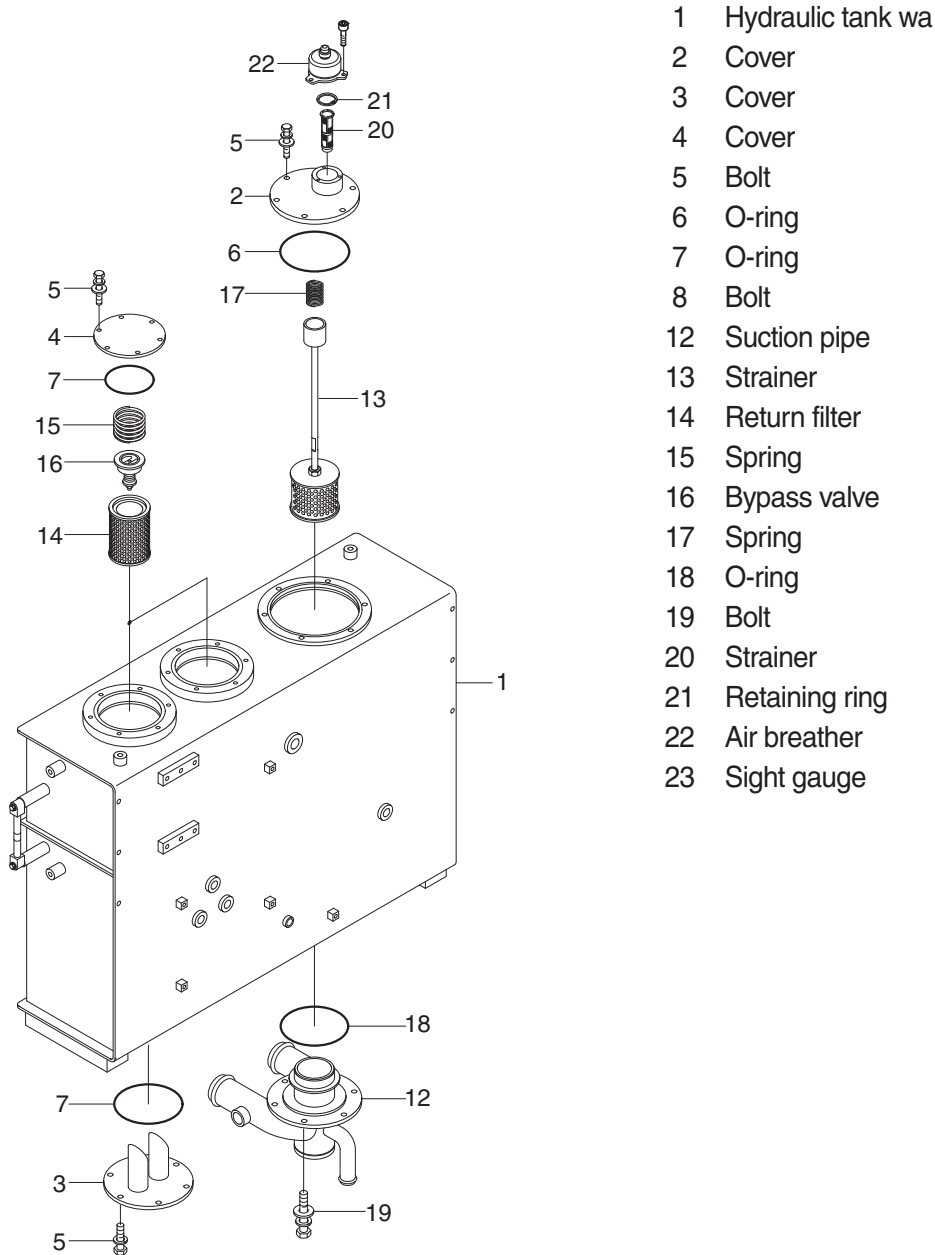

9806WE22

2) RETURN OIL FILTER BYPASS VALVE

(1) When the filter is clogged

Bypass valve (1) is opened and the oil returns directly to the tank without passing through the filter.

- Bypass valve set pressure : 1.36 kg/cm²
(19.3 psi)

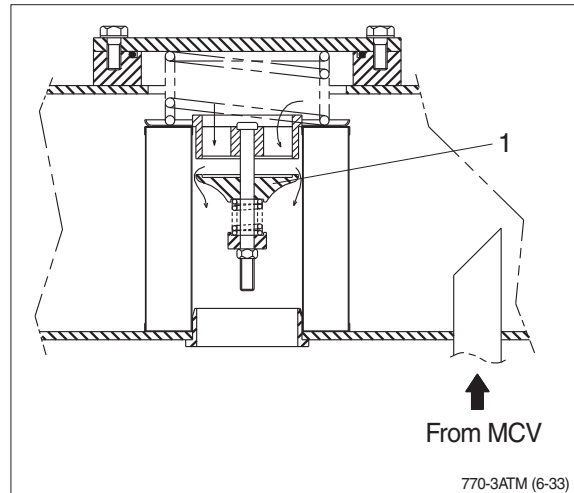

3) AIR BREATHER

The air breather is equipped with the capacity to perform three functions simultaneously-as an air filter, breathing valve, and as a lubrication opening.

(1) Preventing negative pressure inside the tank

The tank is a pressurized sealed type, so negative pressure is formed inside the hydraulic tank when the oil level drops during operations. When this happens, the difference in pressure between the tank and the outside atmospheric pressure opens the poppet in the breather, and air from the outside is let into the tank or prevent negative pressure.

(2) Preventing excessive pressure inside the tank

When the hydraulic cylinder is being used, the oil level in the hydraulic system increases and as temperature rises. If the hydraulic pressure rises above the set pressure, breather is actuated to release the hydraulic pressure inside the tank.

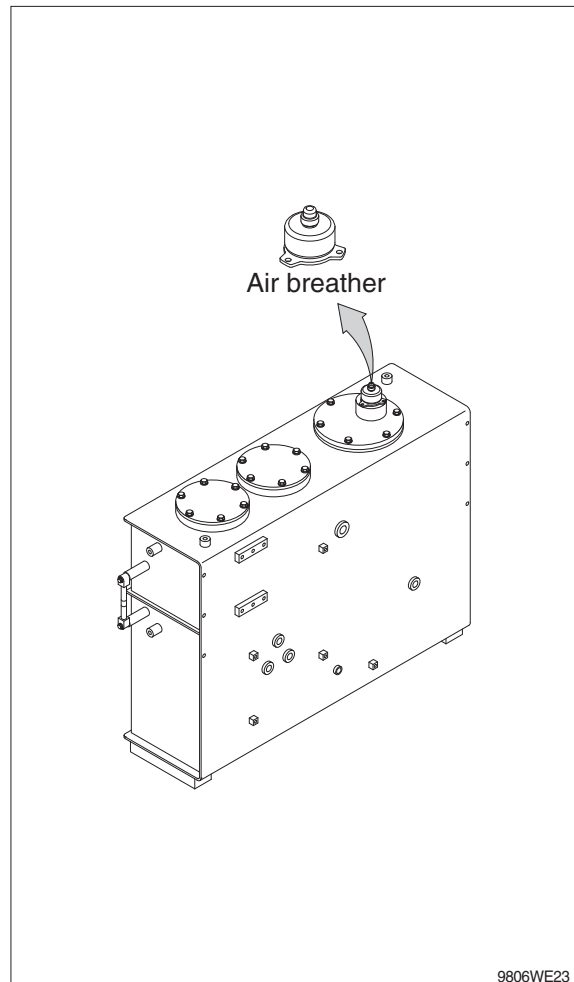

10. ACCUMULATOR

The accumulator is installed at the safety valve. When the boom is left the raised position, and the control levers are operated with the engine stopped the pressure of the compressed nitrogen gas inside the accumulator sends pilot pressure to the control valve to actuate it and allow the boom and bucket to come down under their own weight.

Type of gas	Nitrogen gas (N ₂)
Volume of gas	0.75 l (0.2 U.S.gal)
Charging pressure of gas	16 kg/cm ² (228 psi)
Max actuating pressure	128 kg/m ² (1820 psi)

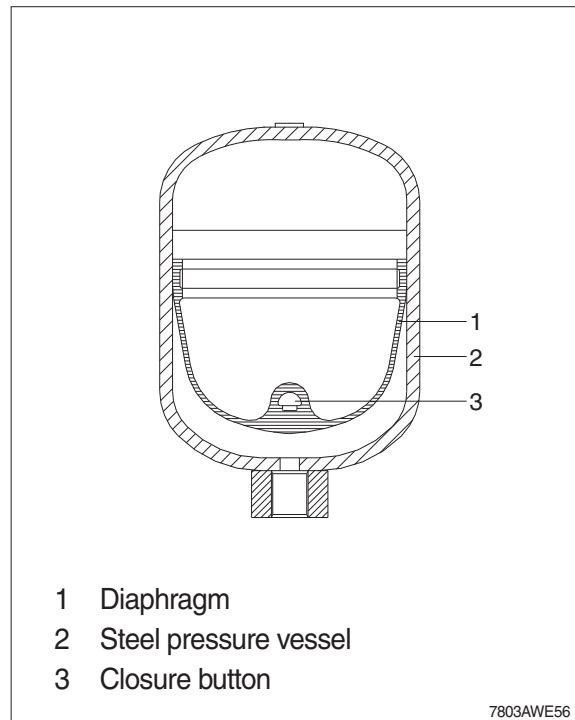

11. RIDE CONTROL SYSTEM (option)

1) ACCUMULATORS

(1) Pre-charging

Use an inert gas such as nitrogen for pre-charging accumulator.

- ※ Do not use oxygen or shop air.
- ※ Nitrogen source and all components must be rated for a pressure at least as high as the nitrogen source.

Accumulator having gas valve as per figure 1.

- ① Remove gas valve guard and gas valve cap.
- ② Back gas chuck "T" handle (A) all the way out (counter clockwise) before attaching charging & gauging kit to accumulator gas valve.
- ③ Close bleed valve (B).
- ④ Making sure not to loop or twist the hose, attach swivel nut (C) to gas valve and tighten 11.5~17 kgf·cm (10~15 lbf·ft).
- ⑤ Turn gas chuck "T" handle (A) until the gauge starts showing the pressure in the accumulator. Do not turn the "T" handle all the way down, as it will damage the valve core.
- ⑥ Crack open nitrogen bottle valve (D) and **slowly** fill accumulator. Shut off when gauge indicates desired pre-charge.
- ⑦ Let the pre-charge set for 10 to 15 minutes. This will allow the gas temperature to stabilize. If the desired pre-charge is exceeded, close nitrogen bottle valve (D), then slowly open bleed valve (B). Do not reduce pre-charge by depressing valve core with a foreign object. High pressure may rupture rubber valve seat.
- ⑧ When finished pre-charging accumulator, turn "T" handle (A) all the way out on gas chuck, then open bleed valve (B).
- ⑨ Hold gas valve to keep from turning, loosen swivel nut (C), remove assembly. Check for pre-charge leak using a common leak reactant.
- ⑩ Replace gas valve cap 11.5~17 kgf·cm (10~15 lbf·ft) and valve guard. (Gas valve cap serves as a secondary seal.)

(2) Pre-charge checking procedure

Using appropriate valve in the hydraulic system, discharge all oil from accumulator and allow piston to bottom against hydraulic end cap.

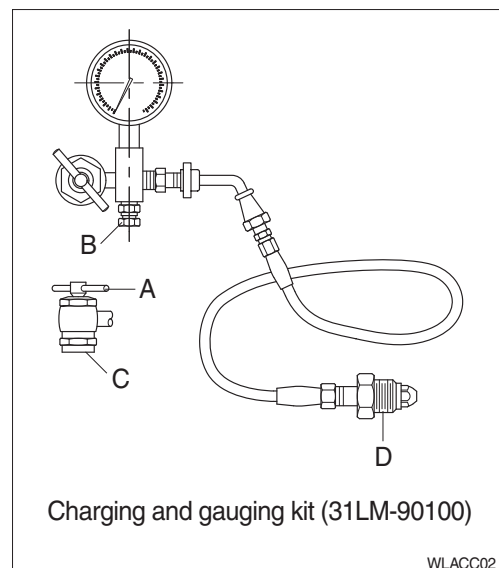
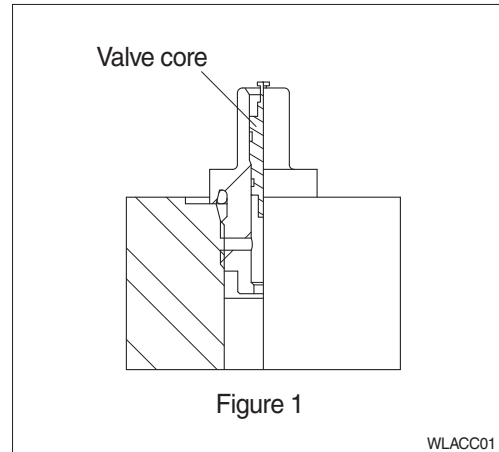

(3) Structure

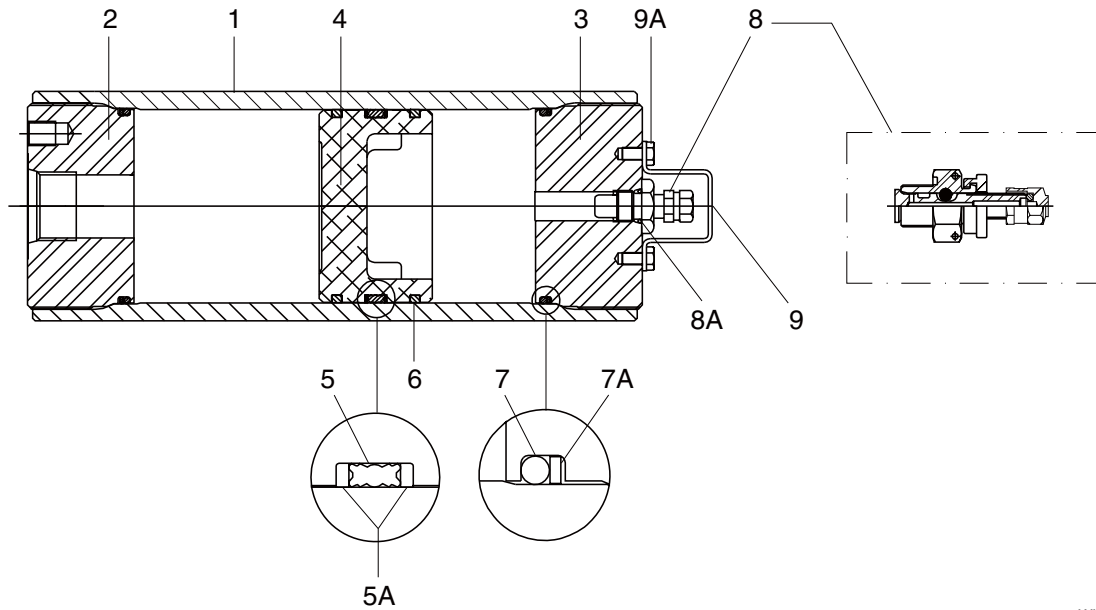

WLACC03

1	Body	5A	V-O-ring back-up washers	8A	Gas valve O-ring
2	Hydraulic cap	6	Piston ring (piston)	9	Gas valve guard
3	Gas cap	7	O-ring	9A	Screw
4	Piston	7A	O-ring back-up washer		
5	V-O-ring	8	Gas valve		

2) REMOVE FROM HYDRAULIC SYSTEM

▲ Attention

- 1) Before carrying out any maintenance work the accumulators must be unloaded (zero pressure).
- 2) For this, unscrew the plug (A) then rotate the drain screw (B), located under the plug (A), 2 turns anti-clockwise with 3 mm L-wrench.
- 3) The lifting system must firstly be secured against lowering.
- 4) After carrying out maintenance work, screw the plug (A) and drain screw (B).
 - Tightening torque
 - A : 0.51 kgf · m (3.69 lbf · ft)
 - B : 0.36 kgf · m (2.58 lbf · ft)

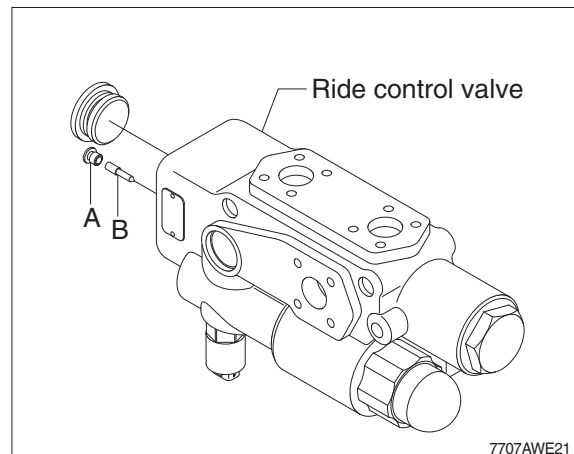

7707AWE21

GROUP 2 OPERATIONAL CHECKS AND TROUBLESHOOTING

1. OPERATIONAL CHECKS

This procedure is designed so the mechanic can make a quick check of the system using a minimum amount of diagnostic equipment. If you need additional information, read structure and function, Group 1.

A location will be required which is level and has adequate space to complete the checks.

The engine and all other major components must be at operating temperature for some checks.

Locate system check in the left column and read completely, following the sequence from left to right. Read each check completely before performing.



At the end of each check, if no problem is found (OK), that check is complete or an additional check is needed. If problem is indicated (NOT OK), you will be given repair required and group location.

If verification is needed, you will be given next best source of information:

- Chapter 2 : Troubleshooting
- Group 3 : Tests and adjustments

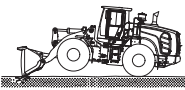
※ Hydraulic oil must be at operating temperature for these checks (refer to page 6-54).

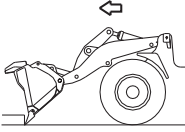
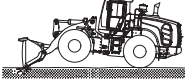
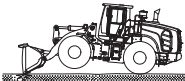
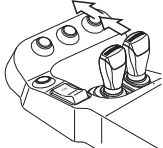
Item	Description	Service action
<p>Hydraulic system warm-up procedure Run engine at high idle.</p>	<p>Hold a hydraulic function over relief to heat oil. (don't keep relief condition over 5 seconds at a time)</p> <p>Periodically cycle all hydraulic functions to distribute warm oil.</p> <p>Repeat procedure until oil is at operating temperature.</p> <p>FEEL : Hydraulic reservoir must be uncomfortable to hold your hand against. (approximately 40 ~50°C)</p>	<p>OK Check completed.</p>
<p>Hydraulic pump performance check Heat hydraulic oil to operating temperature. Run engine at high idle.</p>	<p>With bucket flat on ground, actuate boom raise. Time how long it takes to raise boom to full height.</p> <p>LOOK : Boom must raise to full height in less than 7 seconds.</p>	<p>OK Check completed.</p> <p>NOT OK Go to priority valve (in flow amplifier) high pressure check at page 5-31.</p> <p>IF OK Do steering system leakage check at page 5-30.</p> <p>IF OK Do main hydraulic pump flow test at page 6-55.</p>
<p>Control valve lift check Run machine at low idle.</p>	 <p>With bucket partially dumped, lower boom to raise front of machine.</p> <p>Slowly move boom control lever (RCV lever) to boom lower position.</p> <p>Slowly move bucket control lever to bucket dump position.</p> <p>LOOK : Boom must not raise before moving down.</p> <p>Bucket must not rollback before dumping.</p>	<p>OK Check complete.</p> <p>NOT OK Repair lift checks in loader control valve.</p>

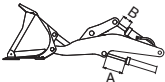
Item	Description	Service action
Bucket rollback circuit relief valve check	 <p>Position bucket at a 45° angle against an immovable object.</p> <p>Engage transmission in 3rd speed forward.</p> <p>LOOK : Bucket angle must not change.</p>	<p>OK Check complete.</p> <p>NOT OK Replace boom lower check valve.</p>
Bucket dump circuit relief valve low pressure check	 <p>Raise front of machine which bucket at 45° angle.</p> <p>Backdrag with bucket while observing bucket angle.</p> <p>LOOK : Bucket must not rollback</p>	<p>OK Go to next check.</p> <p>NOT OK Do loader system and circuit relief valve test at page 6-59.</p>
Pilot control valve float check Run engine at low idle.	 <p>With the bucket partially dumped, lower boom to raise front of machine.</p> <p>Push control lever to the float detent position and release lever.</p>  <p>LOOK : Front of machine lower to the ground and valve must remain in float position when lever is released.</p>	<p>OK Check complete.</p> <p>NOT OK Do pilot control valve pressure test in group 3.</p>
Boom cylinder and bucket cylinder drift check Heat hydraulic oil to operating temperature.	 <p>Set the boom and bucket horizontal, then stop the engine.</p> <p>Stop the engine, wait for 5 minutes, then start measuring.</p> <p>Measure the amount the lift and dump cylinder rods retract during 15 minutes. (unloaded bucket)</p>  <p>A : Retraction of boom cylinder rod B : Retraction of bucket cylinder rod</p> <p>Boom cylinder must drift less than 30 mm</p> <p>Bucket cylinder must drift less than 18 mm</p>	<p>OK Check complete.</p> <p>NOT OK Go to next check.</p>

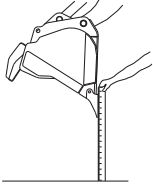
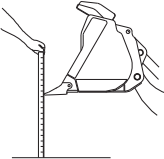
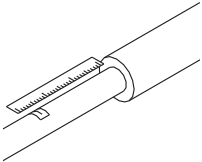
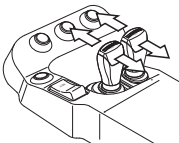
Item	Description	Service action
<p>Boom cylinder leakage check</p> <p>Heat hydraulic oil to operating temperature.</p>	 <p>Dump bucket until teeth or cutting edge is perpendicular to the ground.</p> <p>Raise boom until cutting edge is about 1 m (3 ft) above ground.</p> <p>Stop engine. Measure drift from tooth or cutting edge to ground for 1 minute.</p> <p>Wait 10 minutes.</p> <p>Measure drift from tooth or cutting edge to ground for 1 minute.</p> <p>LOOK : Compare the drift rate between the first measurement and the second measurement.</p>	<p>OK</p> <p>Drift is approximately the same between first and second measurement.</p> <p>Repair loader control valve or circuit relief valve.</p> <p>NOT OK</p> <p>If drift is considerably less on second measurement, repair cylinder.</p>
<p>Bucket cylinder leakage check</p> <p>Heat hydraulic oil to operating temperature.</p>	 <p>Raise bucket about 1 m (3 ft) off ground with bucket level.</p> <p>Stop engine. Place a support under boom.</p> <p>Measure drift from tooth or cutting edge to ground for 1 minute.</p> <p>Wait 10 minutes.</p> <p>Measure drift from tooth or cutting edge to ground for 1 minute.</p> <p>LOOK : Compare the drift rates between the first measurement and the second measurement.</p>	<p>OK</p> <p>Drift is approximately the same between first and second measurement.</p> <p>Repair loader control valve or circuit relief valve at page 6-59.</p> <p>NOT OK</p> <p>Drift is considerably less on second measurement.</p> <p>Repair cylinder.</p>
<p>Check valve of safety valve leakage check</p> <p>Heat hydraulic oil to operating temperature.</p>	 <p>Put bucket level and position about 1.2 m (4 ft) above ground.</p> <p>Place a piece of tape on cylinder rod at least 51 mm (2 in) from rod guide.</p> <p>Run engine at low idle in safety-release position.</p> <p>LOOK : Bucket must not drift up.</p>	<p>OK</p> <p>Check complete.</p> <p>NOT OK</p> <p>Check or replace safety valve.</p>
<p>Pilot control valve (RCV lever) check</p>	 <p>Stop engine. Turn key switch to OFF position.</p> <p>Move control lever to all positions and then release.</p> <p>LOOK : Lever must return to neutral when released from all positions.</p>	<p>OK</p> <p>Check completed.</p> <p>NOT OK</p> <p>Repair pilot control valve.</p>

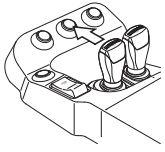
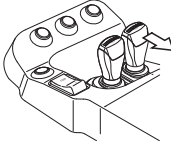
Item	Description		Service action
<p>Bucket leveler (positioner) check</p> <p>Run engine at low idle.</p>		<p>Position bucket fully dumped just above ground level.</p> <p>Move control lever to bucket leveler detent position and release.</p> <p>LOOK : Bucket must rollback to the level position and control lever must return to neutral.</p> <p>If bucket is in a rolled back position when key is turned ON, control lever must be returned to neutral manually if placed in the bucket leveler detent position.</p> <p>After bucket is dumped once, bucket leveler will work normally.</p>	<p>OK Check complete.</p> <p>NOT OK Do bucket leveler checks.</p>
<p>Boom height kickout check</p> <p>Run engine at low idle.</p>		<p>Position bucket flat on ground.</p> <p>Move control lever to boom raise detent position and release.</p> <p>LOOK : Boom must raise to the set height and stop.</p> <p>Control lever must return to neutral.</p>	<p>OK Check complete.</p> <p>NOT OK Do boom height kickout check.</p>
<p>Cycle time check</p> <p>Heat hydraulic oil to operating temperature. Run engine at high idle.</p>	<p>Function</p> <p>Boom raise</p> <p>Boom lower</p> <p>Bucket dump</p> <p>Bucket rollback</p> <p>Steering [No. of turns]</p>	<p>Operating condition.</p> <p>Bucket flat on ground to full height.</p> <p>Full height to level ground.</p> <p>Boom at full height.</p> <p>Boom at full height.</p> <p>Frame stop to frame stop.</p>	<p>Maximum cycle time</p> <p>6.6 sec</p> <p>4.0 sec</p> <p>1.3 sec</p> <p>2.0 sec</p> <p>4.5 turns</p> <p>OK Check complete.</p> <p>NOT OK Go to slow hydraulic functions in group 2.</p>

※ MEASURING BOOM AND BUCKET CYCLE TIME

1) MEASUREMENT CONDITION

- Coolant temperature : Inside operating range
- Steering position : Neutral
- Hydraulic temperature : 40~50°C
- Bucket : Unloaded
- Engine speed : High idling

2) MEASURING TOOL

- Stop watch (1EA)

3) MEASURING PROCEDURE

(1) LIFTING TIME OF BOOM

Set the bucket near the maximum tilt back position and at the lowest position on the ground. Raise the bucket and measure the time taken for bucket to reach the maximum height of the boom.

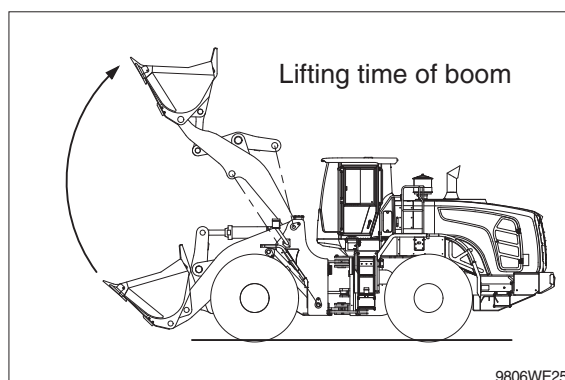

(2) LOWERING TIME OF BOOM

Set the bucket horizontal with the boom at the maximum height, lower the bucket and measure the taken for the bucket to reach the lowest position on the ground.

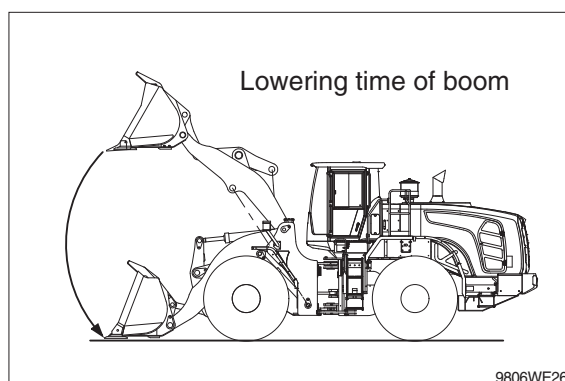

(3) DUMPING TIME OF BUCKET

Raise the boom to the maximum height and measure the time taken for the bucket to move from the maximum tilt back position to the maximum dump position

(4) ROLL BACK TIME OF BUCKET

Raise the boom to the maximum height and measure the time taken for the bucket to reach the maximum tilt back position.

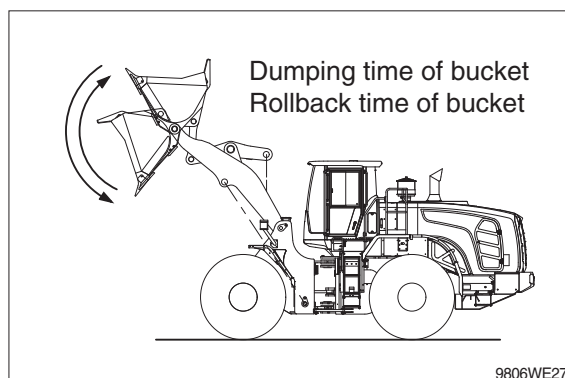

2. TROUBLESHOOTING

※ Diagnose malfunction charts are arranged from most probable and simplest to verify, to least likely, more difficult to verify. Remember the following steps when troubleshooting a problem :

Step 1. Operational check out procedure (see section 1)

Step 2. Operational checks (see group 2)

Step 3. Troubleshooting

Step 4. Tests and adjustments (see group 3)

Problem	Cause	Remedy
Noisy hydraulic pump	<p>Low oil supply or wrong viscosity.</p> <p>Plugged or pinched suction line.</p> <p>Air in oil.</p> <p>Plugged suction strainer.</p> <p>Loose or missing hydraulic line clamps.</p> <p>Hydraulic lines in contact with frame.</p> <p>Worn or damaged pump.</p>	<p>Fill reservoir with recommended oil.</p> <p>Clean or replace line.</p> <p>Check for foamy oil. Tighten connections.</p> <p>Replace O-rings and or lines.</p> <p>Inspect and clean strainer in reservoir.</p> <p>Tighten or replace clamps.</p> <p>Inspect and repair.</p> <p>Do hydraulic pump performance check in group 2. Do hydraulic pump flow test in group 3.</p>
No or Slow hydraulic functions	<p>Failed or worn hydraulic pump.</p> <p>Cold oil.</p> <p>Slow engine speed.</p> <p>Suction line air leak.</p> <p>Low oil supply.</p> <p>Wrong oil viscosity.</p> <p>Oil leaking past cylinders or control valve.</p> <p>Blocked or damaged line.</p> <p>Faulty pilot control valve (RCV).</p> <p>Binding loader control valve (MCV) spool.</p> <p>Faulty flow amplifier.</p>	<p>Do performance check.</p> <p>Warm oil up.</p> <p>Adjust engine speed.</p> <p>Check high idle speed.</p> <p>Check for foamy oil.</p> <p>Add recommended oil.</p> <p>Use recommended oil.</p> <p>Check cylinder drift in group 2.</p> <p>Inspect lines.</p> <p>Do pilot control valve (RCV) pressure test in group 3.</p> <p>Inspect valve.</p> <p>Check priority valve, orifice of flow amplifier specification.</p>

Problem	Cause	Remedy
No steering or hydraulic function	Low oil level. Failed hydraulic pump.	Add recommended oil. Remove and inspect return filter for metal pump particles.
No hydraulic functions steering normal	Failed hydraulic pump. Failed line filter. Faulty safety valve. Stuck open port relief valve.	Remove and inspect return filter for metal pump particles, or replace the pump. Remove and inspect line filter for RCV. Safety valve leakage test or ON, OFF function test. Replace relief valve.
Boom float function does not work	Low pilot control pressure. Faulty pilot control valve (RCV). Loader control valve (MCV) spool binding in bore.	Do pressure reducing valve pressure test in group 3. Replace relief valve. Do pressure reducing valve pressure test in group 3.
One hydraulic function does not work.	Faulty pilot control valve (RCV). Stuck open port relief valve. Oil leaking past cylinder packings. Blockage in oil lines or valve. Loader control valve (MCV) spool stuck in bore.	Do pilot control valve pressure test. Inspect and repair valve. Replace relief valve. Do boom and bucket cylinder leakage test in group 3. Inspect lines for damage. Disconnect and inspect lines for internal blockage. Inspect and repair valve.
Low hydraulic power	Leakage within work circuit. Low system relief valve (main relief valve) setting. Low port relief valve setting. Leaking system relief valve. Worn hydraulic pump. Faulty pilot control valve (RCV).	Do cylinder drift check in group 2. Do loader system and port relief valve pressure test in group 3. Do loader system and port relief valve pressure test in group 3. Remove and inspect valve. Do hydraulic pump performance check in group 2. Do pilot control valve pressure test in group 3.

Problem	Cause	Remedy
Function drifts down	Leaking cylinders. Leaking seals in circuit relief valve (port relief valve) or valve stuck open. Leaking loader control valve (MCV).	Do cylinder leakage checks in group 3. Inspect seals. Replace relief valve. Repair or replace valve section.
Boom drifts up	Leakage in boom down spool.	Remove and inspect boom down spool.
Boom down does not work (engine off)	Safety valve not operated. Stuck pilot control valve. Faulty line filter. Accumulation not operated. MCV spool stuck.	Operate valve. Inspect. Remove and inspect filter. Inspect. Inspect and repair valve.
Oil overheats	Low oil viscosity in hot weather. Excessive load. Holding hydraulic system over relief. Leakage in work circuit. Plugged fins in oil cooler. Internally plugged oil cooler. Incorrect system or circuit relief valve setting. Restriction in oil lines or loader control valve (MCV). Malfunctioning steering valve. Leaking system main relief valve. Worn hydraulic pump (internal leakage).	Use recommended oil. Reduce load. Reduce load. Do boom and bucket cylinder leakage test in group 3. Inspect and clean oil cooler. Do hydraulic oil cooler restriction test. Do loader system and circuit relief valve pressure test in group 3. Inspect for dented or kinked lines. Do hydraulic system restriction test in group 3. Do hydraulic system restriction test in group 3. Remove and inspect valve and seals. Do hydraulic pump performance check in group 2.
Function drops before raising when valve is activated	Stuck open lift check valve.	Do control valve lift check in group 2.

Problem	Cause	Remedy
Hydraulic oil foams	Low oil level. Wrong oil. Water in oil. Loose or faulty suction lines (air leak in system).	Add recommended oil. Change to recommended oil. Change oil. Tighten or install new lines.
Remote control valve (RCV) leaking	Leaking plunger seals.	Remove, inspect and replace plunger seals.

※ Followings are general precautions for the hydraulic system and equipment.

- 1) Every structure has its limit of strength and durability. The relief valve is installed to limit the pressure on the hydraulic equipment and protect various parts of the wheel loader from possible damage. Therefore, never change the preset pressure of the relief valve unless absolutely necessary.
- 2) Since the hydraulic equipment is built with precision, the presence of only the slightest amount of dust and / or other particles in the hydraulic circuit might cause wear and/or damage, resulting in unstable functions and/or damage, resulting in unstable functions and/or unexpected accidents. Therefore, always keep hydraulic oil clean. Periodically, check the filter in the return circuit and replace the element as necessary.
- 3) Extract about 200cc of hydraulic oil from the tank as a sample every 6 months. If possible, have it analyzed by a specialist to confirm that the oil can still be used. Never extract the oil for sampling until the oil temperature has become the normal operating temperature. Since the replacement period varies depending on operating conditions, refer to **Operator's Manual** and change oil.
- 4) Should the equipment get damaged due to the presence of metal particles and/or foreign matter in the circuit drain out the hydraulic oil and carry out flushing. Also, replace the filter element and clean the hydraulic tank. Change the hydraulic oil entirely.
- 5) When checking the filter, if found metal particles in the element, drain out the hydraulic oil entirely, flush the whole circuit, and then fill with new oil. The presence of metal particles may indicate internal damage to the equipment. In such a case, check carefully before flushing, and repair or replace as required.
- 6) To add and/or change the hydraulic oil, always use recommended oil. (Refer to the list of recommended oils and lubricants at page 1-20, **Recommended lubricants**.) Never mix oil of different makes of kinds.
- 7) To change the hydraulic oil, use a clean vessel and funnel for pouring it into the tank. Never use cloth because it might cause the presence of lint in the circuit.
- 8) When removing the hydraulic equipment, be sure to put plugs or caps on hoses, tube lines and ports. Also, enter mating marks for later identification.

- 9) Disassemble and/or assemble the hydraulic equipment only in a clean place free of dust. When disassembling, be careful about the interchangeability of parts, and clean the disassembled parts with pure and clean mineral cleansing oil. Clean the internal passages as well. After the parts have dried, wipe them off with a clean lint-free cloth.
- 10) When overhauling the hydraulic equipment replace all O-rings, backup rings, etc. with new ones. Assemble O-rings with grease or vaseline applied.
- 11) After installing the equipment, add more hydraulic oil to make up for that lost during disassembly.
- 12) Tighten joints correctly. Loose joints will cause the hydraulic oil to leak. If the oil leaks, the tank oil level drops and air gets sucked in, so the pump will break down. Also loose joints in suction lines will take air in and might cause abnormal noise, malfunction or damage to pumps.

GROUP 3 TESTS AND ADJUSTMENTS

1. HYDRAULIC OIL CLEAN UP PROCEDURE USING PORTABLE FILTER CADDY

- ※ Service equipment and tool
 - Portable filter caddy
 - Two 4000 mm × 1in 100R1 Hoses
 - Quick disconnect fittings.
 - Discharge wand
 - Various size fittings.
 - ※ Brake system uses oil from hydraulic oil tank. Flush all lines in the brake, pilot, steering system and cut off system. Disassemble and clean major components for brake and steering system. Remove and clean pilot caps from main control valve.
Brake and steering components may fail if brake and steering system is not cleaned after hydraulic oil tank contamination.
- 1) If hydraulic system is contaminated due to a major component failure, remove and disassemble steering cylinders to clean debris from cylinders.
 - 2) Install a new return filter element. Inspect filter housing before installing new element.
 - ※ For a failure that creates a lot of debris, remove access cover from hydraulic oil tank. Drain and clean hydraulic oil tank of fill the specified oil to hydraulic oil tank through upper cover.
 - 3) To minimize oil loss, pull a vacuum in hydraulic oil tank using a vacuum pump. Connect filter caddy suction line to drain port at bottom of hydraulic oil tank using connector. Check to be sure debris has not closed drain port.
 - 4) Put filter caddy discharge line into hydraulic oil tank filler hole so end is as far away from drain port as possible to obtain a thorough cleaning of oil.

- 5) Start the filter caddy. Check to be sure oil is flowing through the filters.
Operate filter caddy approximately 10 minutes so oil in hydraulic oil tank is circulated through filter a minimum of four times.
 - ※ Hydraulic oil tank capacity : 186 l (49.1 U.S. gal)Leave filter caddy operation for the next steps.
- 6) Start the engine and run it at high idle.
 - ※ For the most effective results, cleaning procedure must start with the smallest capacity circuit then proceed to the next largest capacity circuit.
- 7) Operate all functions, one at a time, through a complete cycle in the following order: Clam, steering, bucket, and boom. Also include all auxiliary hydraulic functions. Repeat procedure until the total system capacity has circulated through filter caddy seven times, approximately 30 minutes. Each function must go through a minimum of three complete cycles for a through cleaning for oil.
 - ※ Filtering time for machines with auxiliary hydraulic functions must be increased because system capacity is larger.
- 8) Stop the engine. Remove the filter caddy.
- 9) Install a new return filter element.
- 10) Check oil level in reservoir; Add oil if necessary.

2. BOOM HEIGHT KICKOUT ADJUSTMENT

The bucket can be adjusted to a height desired by using the boom kick-out device.

- ▲ Park the machine on level ground and block the tires to prevent sudden movement of the machine.
- ▲ Press the parking brake switch.
- ▲ Fix the front and rear frames by using the safety lock bar.
- ▲ Do not work underneath the work equipment.

1) ADJUSTMENT OF THE BOOM KICKOUT AND BUCKET LEVELER

(1) Lift kickout position

To set the lift kickout, raise the bucket to the desired position above the midway point. Then push icon ( , A) for 2~3 seconds. The boom will return to the programmed position when the raise detent is activated and the boom is below the kickout position.

(2) Lower kickout position

To set the lower kickout, lower the bucket to the desired position below the midway point. Then push icon ( , A) for 2~3 seconds. The boom will return to the programmed position when the float detent is activated and the boom is at least a foot above the kickout position.

(3) Bucket leveler position

To set the bucket leveler, roll back the bucket to the desired position. Then push icon ( , B) for 2~3 seconds. The bucket will return to the programmed position when the roll back detent is activated and the bucket is below the leveler position.

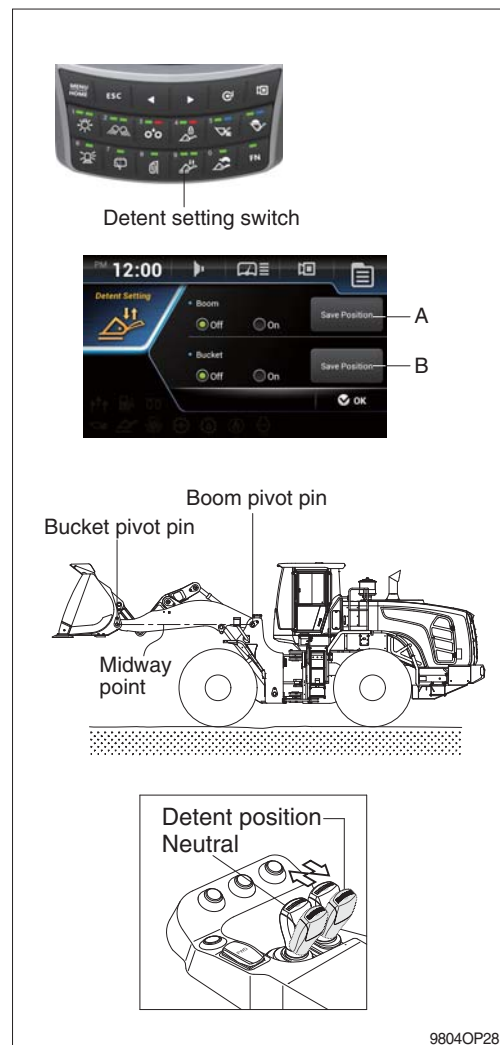

3. TEST TOOLS

1) CLAMP-ON ELECTRONIC TACHOMETER INSTALLATION

- Service equipment and tools
- Tachometer

A : Clamp on tachometer.

Remove paint using emery cloth and connect to a straight section of injection line within 100 mm (4 in) of pump. Finger Tighten only-do not over tighten.

B : Black clip (-). Connect to main frame.

C : Red clip (+). Connect to transducer.

D : Tachometer readout. Install cable.

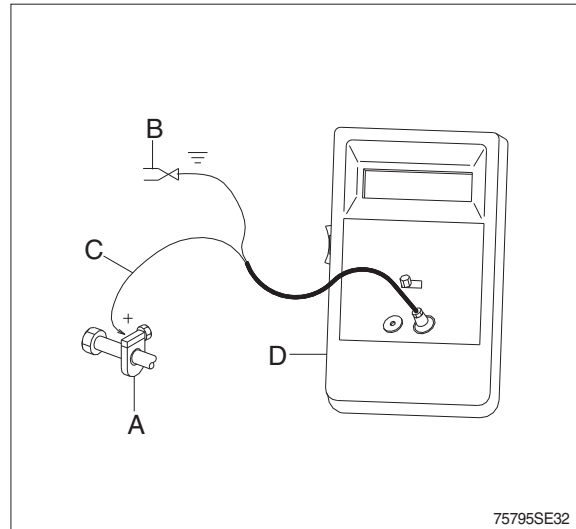

2) DIGITAL THERMOMETER INSTALLATION

- Service equipment and tools
- Digital thermometer

A : Temperature probe.

Fasten to a bare metal line using a tie band. Wrap with shop towel.

B : Cable.

C : Digital thermometer.

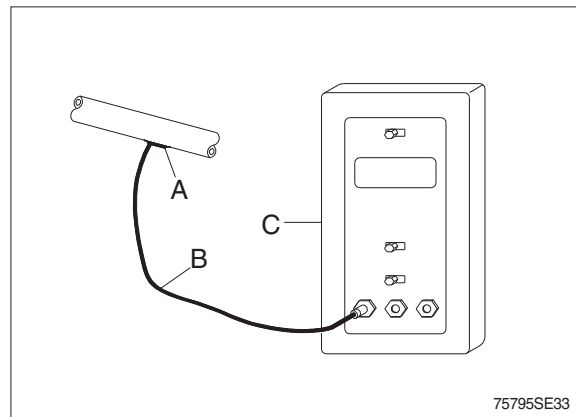

3) DISPLAY MONITOR TACHOMETER

The display monitor tachometer is accurate enough for test work.

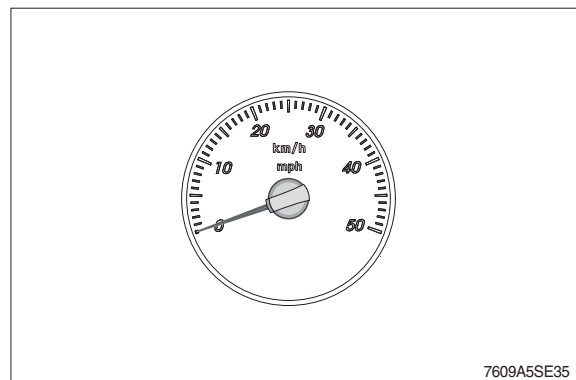

4. HYDRAULIC OIL WARM UP PROCEDURE

- 1) Install temperature reader (see temperature reader installation procedure in this group).
- 2) Run engine at high idle.
- 3) Hold a hydraulic function over relief to heat the oil.
- 4) Periodically cycle all hydraulic functions to distribute warm oil.
- 5) Heat oil to test specification (approx. 45°C).

※ Ride control system (option)

▲ Attention

- 1) Before carrying out any maintenance work the accumulators must be unloaded (zero pressure).
 - 2) For this, unscrew the plug (A) then rotate the drain screw (B), located under the plug (A), 2 turns anti-clockwise with 3 mm L-wrench.
 - 3) The lifting system must firstly be secured against lowering.
 - 4) After carrying out maintenance work, screw the plug (A) and drain screw (B).
 - Tightening torque
- A : 0.51 kgf · m (3.69 lbf · ft)
B : 0.36 kgf · m (2.58 lbf · ft)

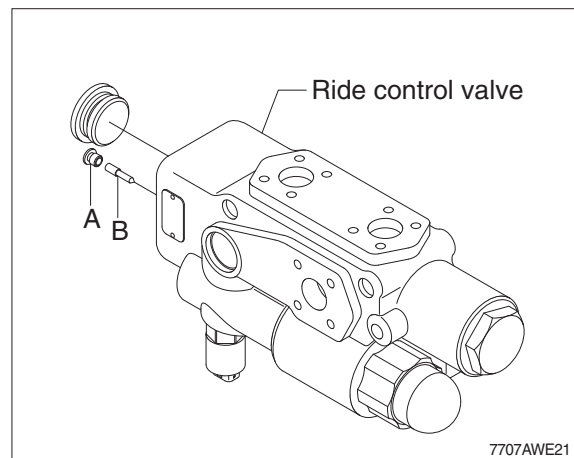

5. MAIN HYDRAULIC PUMP FLOW TEST

· SPECIFICATION

Oil temperature	$45 \pm 5^\circ\text{C}$ ($113 \pm 9^\circ\text{F}$)
Engine speed	2100 ± 25 rpm
Test pressure	280 ± 5 bar (3980 psi)
Maximum pump flow	397 l/min (105 gpm) (steering+loader pump)

· FLOW METER, GAUGE AND TOOL

Gauge	0~35 MPa (0~350 bar, 0~5000 psi)
Temperature reader	

- 1) Make test connections.
- 2) Install temperature reader.
(see temperature reader installation procedure in this group)
- 3) Heat hydraulic oil to specifications.
(see hydraulic oil warm up procedure in this group)
- 4) Run engine at test specifications.
- 5) Close flow meter loading valve to increase pressure to test specifications.
- 6) Read flow meter.
- 7) If flow is below specifications, check suction line and suction pressure for abnormality before removing pump.

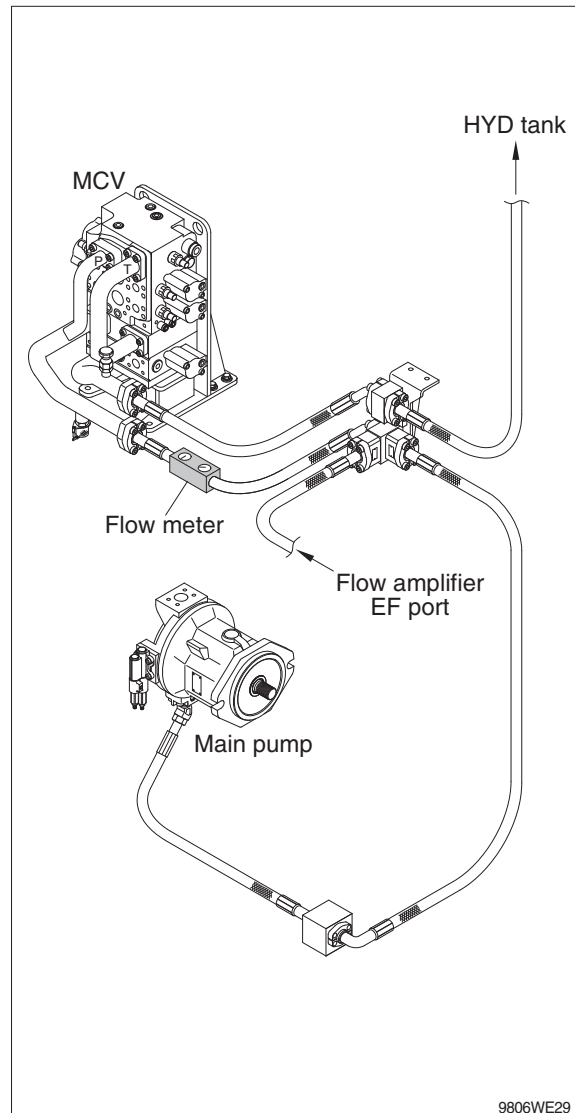

6. LOADER SYSTEM AND PORT RELIEF VALVE PRESSURE TEST

· SPECIFICATION

Oil temperature (40~50°C)

Relief valve	Engine speed	Relief pressure
System (M)	Low	280 ± 5 kg/cm ² (3980 ± 70 psi)
Boom raise (U)	Low	340 ± 10 kg/cm ² (4840 ± 140 psi)
Bucket rollback (R)	Low	340 ± 10 kg/cm ² (4840 ± 140 psi)
Bucket dump (D)	Low	300 ± 10 kg/cm ² (4270 ± 140 psi)

· Gauge and tool

Gauge 0~35 MPa (0~350 bar, 0~5000 psi)

M : System (main) relief valve

R : Bucket rollback relief

D : Bucket dump relief

U : Boom raise relief

- 1) Install fitting and pressure gauge to test port in pump delivery line.
- 2) Install temperature reader.
(see temperature reader installation procedure in this group)
- 3) Heat hydraulic oil to specifications.
(see hydraulic oil warm up procedure in this group)
- 4) To check the system relief (M), run engine at low idle. Lower boom to bottomed position.
Slowly activate boom down function while watching pressure gauge. If pressure is not to specification, loosen lock nut on system relief valve (M) and adjust to specification.

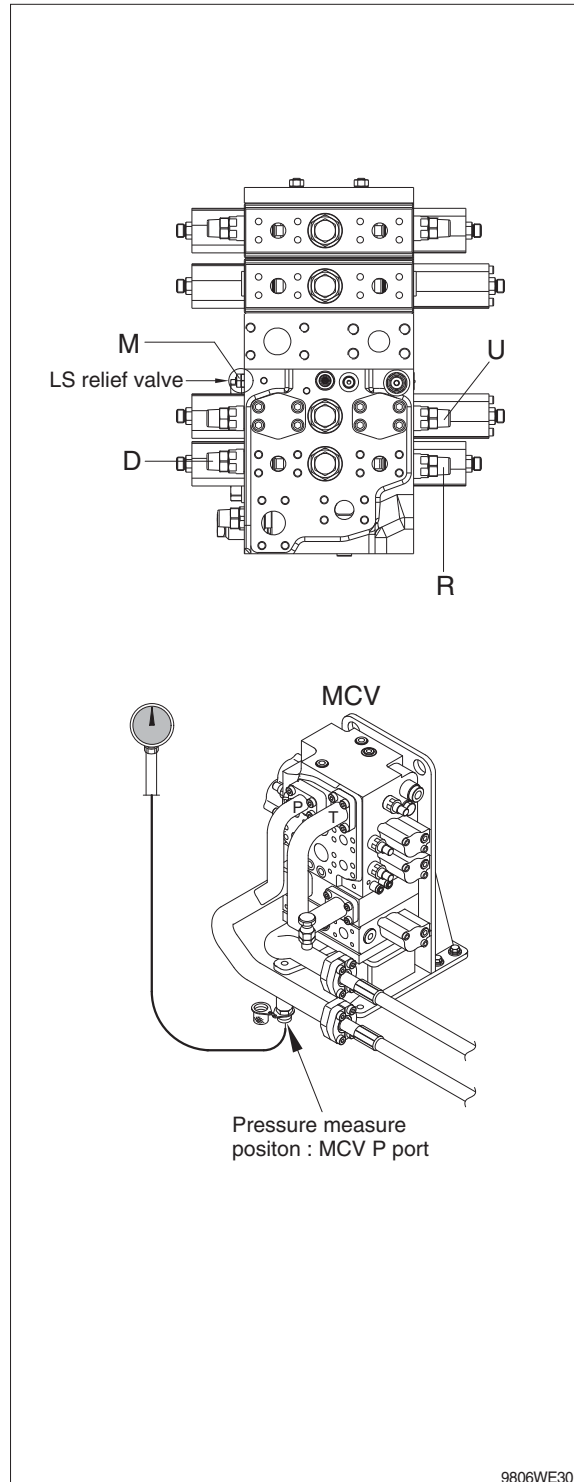

※ Do not adjust the system relief valve above 280 kg/cm² (3980 psi). Damage to the pump will result from excessive pressure settings.

7. HYDRAULIC SYSTEM RESTRICTION TEST

· SPECIFICATION

Oil temperature $45 \pm 5^{\circ}\text{C}$ ($113 \pm 9^{\circ}\text{F}$)

Engine speed High idle

Maximum pressure 4.5 MPa (45 bar, 640 psi) at flow amplifier.

Maximum pressure at main control valve
1 MPa (10 bar, 145 psi)

· GAUGE AND TOOL

Gauge 0~7 MPa (0~70 bar, 0~1000 psi) 2EA

This test will check for restrictions in the hydraulic system which can cause overheating of hydraulic oil.

- 1) Install temperature reader.
(see temperature reader installation procedure in this group)
 - 2) Heat hydraulic oil to specifications.
(see hydraulic oil warm up procedure in this group)
 - 3) Connect fitting and gauge to steering valve.
 - 4) Connect fitting and gauge to main control valve.
- ▲ Do not operate steering or loader functions or test gauge may be damaged.**
- 5) Run engine at specification and read pressure gauges.

If pressure is more than specification at the loader control valve, check for a kinked, dented or obstructed hydraulic line. Check loader control valve for a binding spool.

If pressure is more than specification at the steering unit, inspect neutral condition of the steering unit and flow amplifier for a stuck spool. Make sure orifice plugs are installed in ends of priority valve spool.

Check for plugged orifice in priority valve and dynamic signal orifice on flow amplifier body.

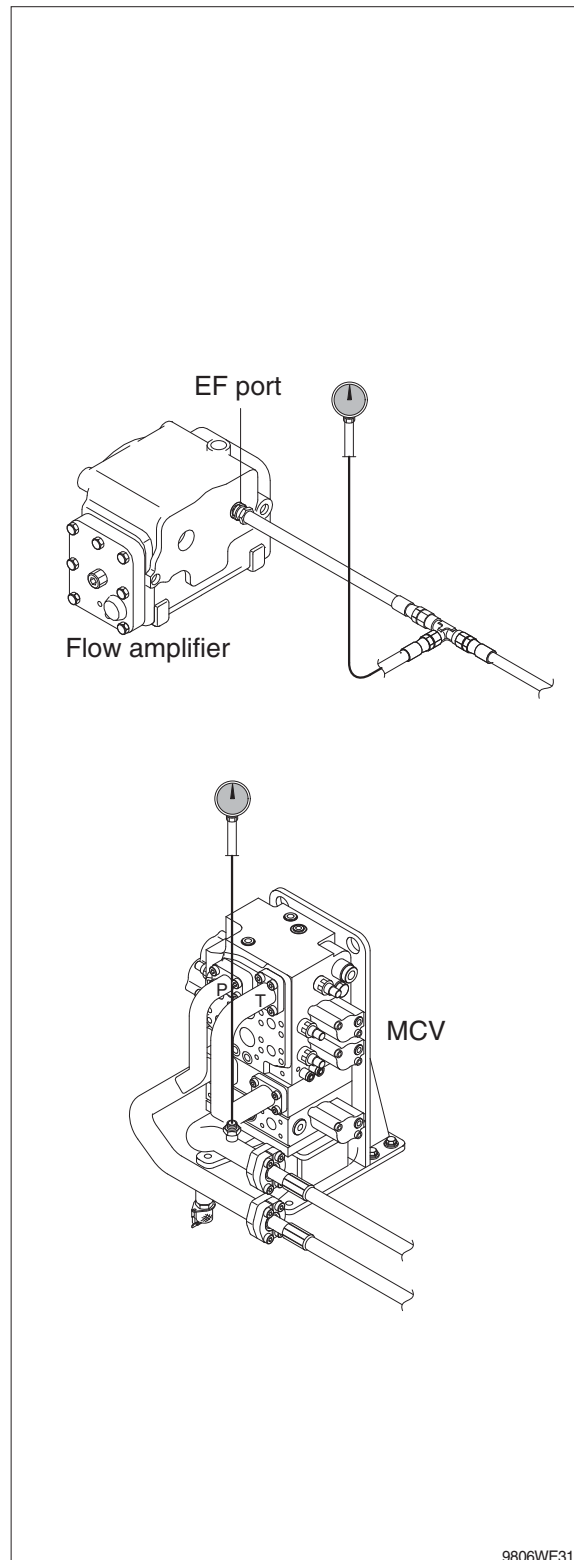

8. LOADER CYLINDER DRIFT TEST

· SPECIFICATION

Oil temperature $45 \pm 5^{\circ}\text{C}$ ($113 \pm 9^{\circ}\text{F}$)

Boom horizontal

Bucket horizontal

Bucket unloaded

Item	Standard value
Retraction of boom cylinder rod	30 mm
Retraction of bucket cylinder rod	15 mm

· GAUGE AND TOOL

Stop watch

Temperature reader

⚠ Put the safety lock lever in the lock position.

⚠ Do not go under the work equipment.

- 1) Set the boom and bucket horizontal, then stop the engine.
- 2) Stop the engine, wait for 5 minutes, then start measuring.
- 3) Measure the amount the boom and bucket cylinder rods retract during 15 minutes.

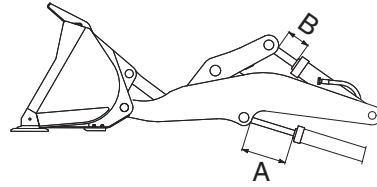

A : Retraction of boom cylinder rod

B : Retraction of bucket cylinder rod

7577AWE31

9. BOOM AND BUCKET CYLINDER LEAKAGE TEST

· SPECIFICATION

Oil temperature $45 \pm 5^{\circ}\text{C}$ ($113 \pm 9^{\circ}\text{F}$)
Engine speed Low idle
Maximum leakage 15 ml/min (1/2 oz/min)

· GAUGE AND TOOL

Temperature reader
Stop watch
Measuring container

1) Fasten temperature sensor to head end port of cylinder to be tested. Cover sensor with a shop towel.

2) Heat hydraulic oil to specifications (see hydraulic oil warm up procedure in this group).

⚠ Never work under raised equipment unless it is supported with a hoist or support stands.

3) Full extend the cylinder to be tested. If testing the boom cylinders, restrain boom in the fully raised position using a hoist or a stand.

※ Check cylinders for leakage in the fully extended position only. In the retracted position contacts the end of the cylinder and seals off piston seal leakage.

4) Remove and plug cylinder rod end hose or line.

5) Run engine at slow idle. Activate control lever to extend cylinder for 1 minute over relief while measuring leakage for open port.

If leakage is within specification, excessive cylinder drift is caused by leakage in the loader control valve or circuit relief valve.

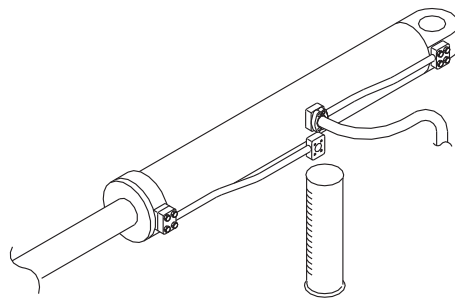

(770-3ATM) 6-56

10. PILOT CONTROL VALVE (EH CONTROL BLOCK) PRESSURE TEST

· SPECIFICATION

Oil temperature $45 \pm 5^{\circ}\text{C}$ ($113 \pm 9^{\circ}\text{F}$)
Engine speed High idle
Maximum pressure 3.0 MPa (30 bar, 427 psi)

GAUGE AND TOOL

- 1) Gauge 0~7 MPa (0~70 bar, 0~1000 psi)
- 2) Lower boom to ground.
Connect gauge to the pilot pressure port of function to be checked.
- 3) Install temperature reader (see temperature reader installation procedure in this group).
- 4) Heat hydraulic oil to specification (see hydraulic oil warm up procedure in this group).

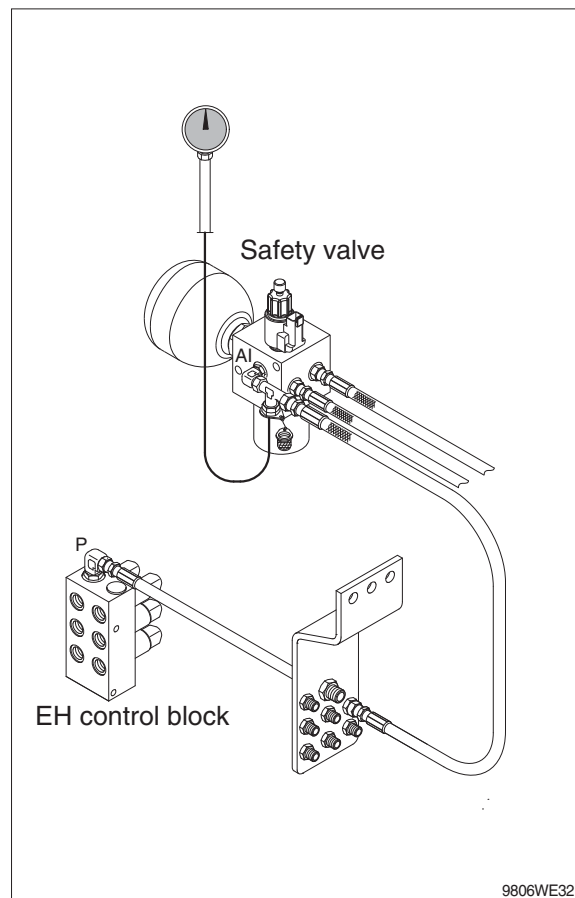

11. CYCLE TIME TEST

· SPECIFICATION

Oil temperature — $45 \pm 5^{\circ}\text{C}$ ($113 \pm 9^{\circ}\text{F}$)

Engine speed — High idle

Function	Operating conditions	Maximum cycle time (seconds)
Boom raise	Bucket flat on ground to full height	6.6
Boom lower (float)	Full height to ground level	4.0
Bucket dump	Boom at full height	1.3
Bucket rollback	Boom at full height	2.0
Steering (number of turns)	Frame stop to stop	4.5 turns

Hydraulic pump performance cycle time.

Function	Operating conditions	Maximum cycle time (seconds)
Boom raise	Bucket flat on ground to full height while holding steering over relief	10

12. HYDRAULIC OIL FILTER INSPECTION PROCEDURE

- 1) Lower the bucket to the ground, stop the engine, move the control lever back and forth several times, and clean all over the upper surface of the hydraulic oil tank.
- 2) Remove the bolts and take out the filter case cover and O-ring.
- 3) Remove the spring and bypass valve.
- 4) Remove the filter element from the tank.
- 5) Check the element and the filter case bottom for debris. Excessive amounts of brass and steel particles can indicate a failed hydraulic pump or a pump failure in process. A rubber type of material can indicate cylinder packing or other packing failure.

※ The hydraulic oil filter in the filter case of the hydraulic oil tank should be replaced every 250 operating hours or more often. When the filter element is replaced, please keep as follows.

- (1) Clean the inside of the filter case.
- (2) Place new element in the proper positions inside the filter case.
- (3) Install the bypass valve and spring. Make sure the element stand upright, and check for complete contact of the element bottom with the filter case bottom.
- (4) Install the O-ring and filter case covers. Tighten them with bolt. Replace the O-ring with new one if damaged.

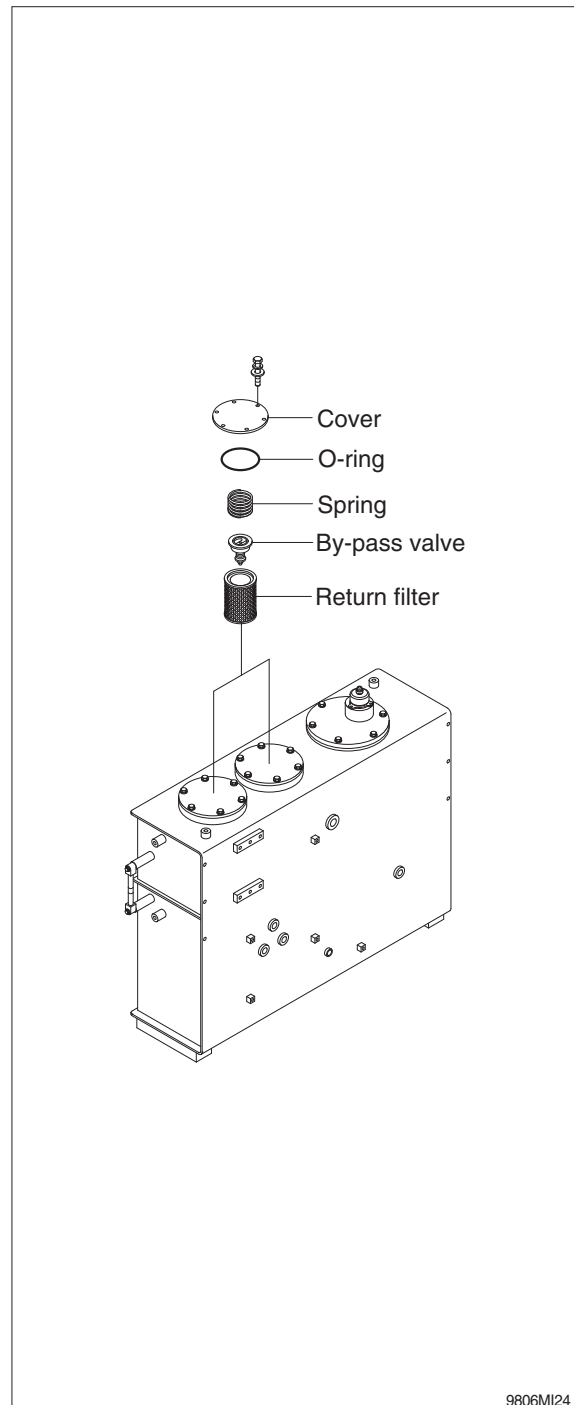

GROUP 4 DISASSEMBLY AND ASSEMBLY

1. MAIN PUMP (STEERING PUMP, LOADER PUMP)

1) STRUCTURE

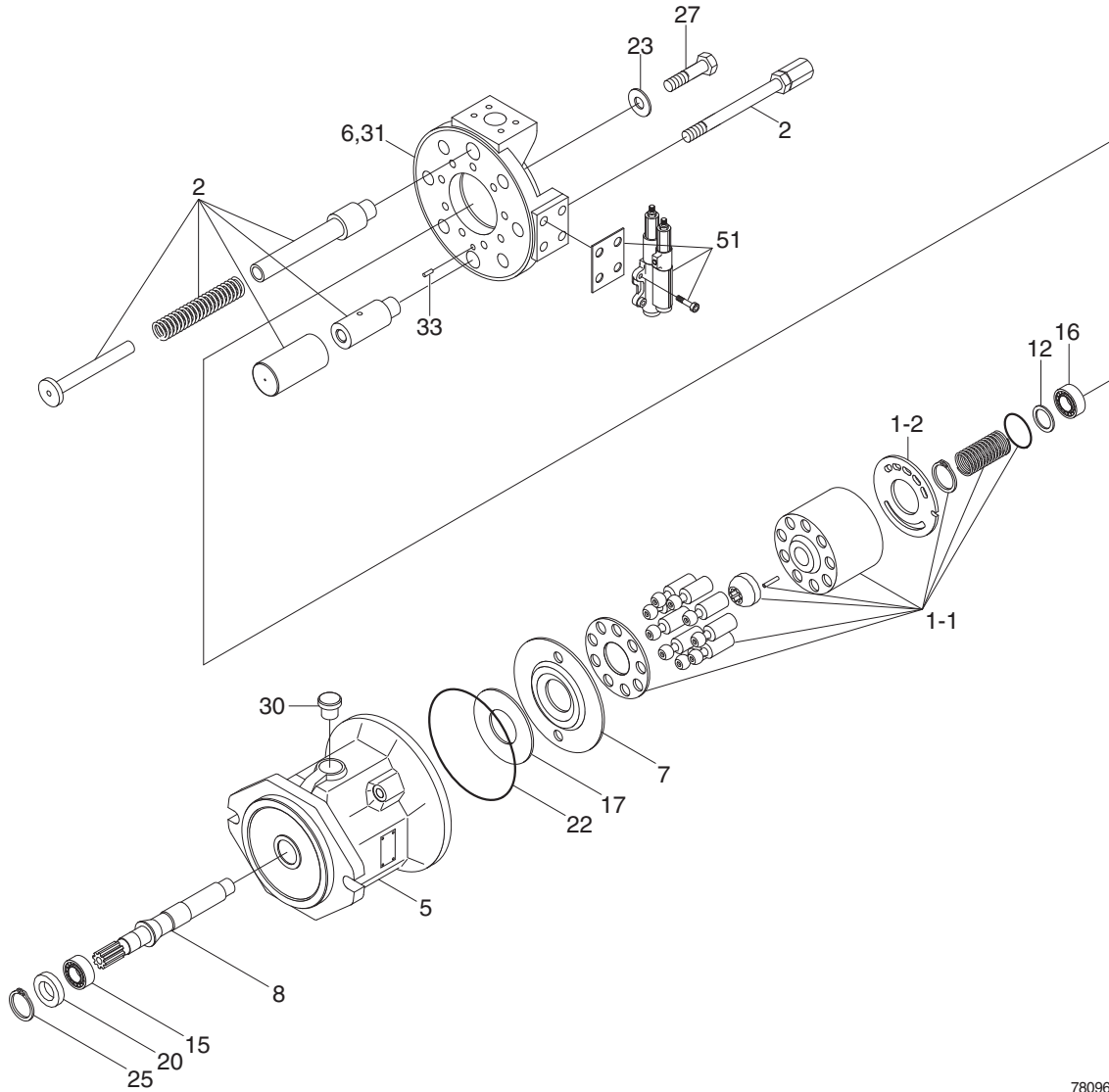

78096WE11

- | | | | | | |
|-----|-------------------------|----|----------------------|----|----------------------|
| 1 | Rotary group | 8 | Drive shaft | 23 | O-ring |
| 1-1 | High speed rotary group | 12 | Adjustment shim | 25 | V-ring |
| 1-2 | Control plate | 15 | Taper roller bearing | 27 | Socket screw |
| 2 | Adjusting piece | 16 | Taper roller bearing | 30 | Locking screw |
| 5 | Pump housing | 17 | Bearing liner | 31 | Double break-off pin |
| 6 | Port plate | 20 | Shaft seal ring | 33 | Cylinder pin |
| 7 | Swash plate | 22 | O-ring | 51 | Control valve |

2) GENERAL REPAIR GUIDELINES

- ※ Observe the following guidelines when carrying out repairs on hydraulic pumps.
- (1) Close off all openings of the hydraulic unit.
- (2) Replace all of the seals.
Use only original spare parts.
- (3) Check all sealing and sliding surfaces for wear.
- ※ Re-work of the sliding surfaces by using, for example abrasive paper, can damage the surface.
- (4) Fill the hydraulic pump with hydraulic oil before commissioning.

3) SEALING THE DRIVE SHAFT

- (1) Protect the drive shaft.
Remove the circlip.
Remove the shaft seal.

1 Circlip 2 Shaft seal

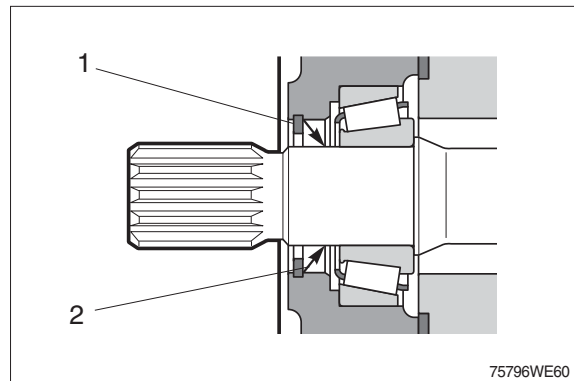

- (2) Change the shaft seal and check its sliding surface (drive shaft) and housing, grease the sealing ring.

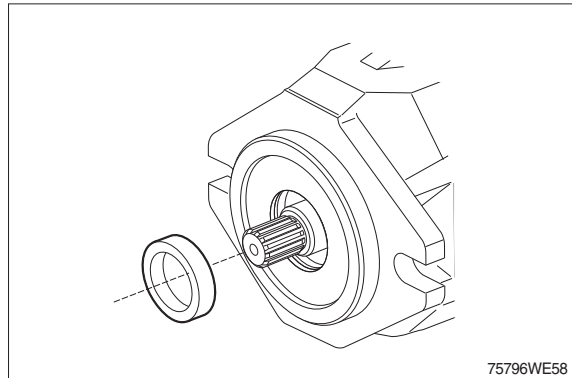

- (3) Assemble the sealing ring, fitting tool holds the correct position of the sealing ring in the pump housing.
Assemble the circlip in the correct position.

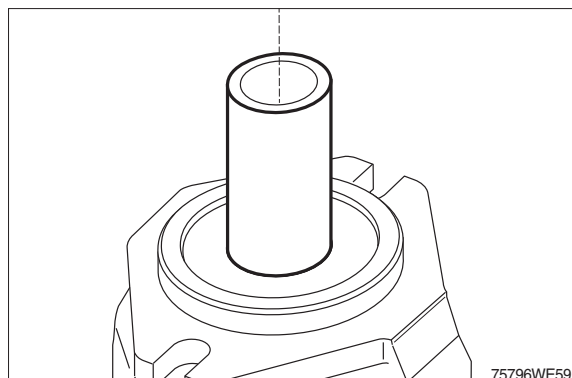

4) SEALING / CLEANING THE CONTROL VALVE

- (1) Disassemble the control valve.
- ※ Measure dimension A and note down.
- Check sealing surface (1).

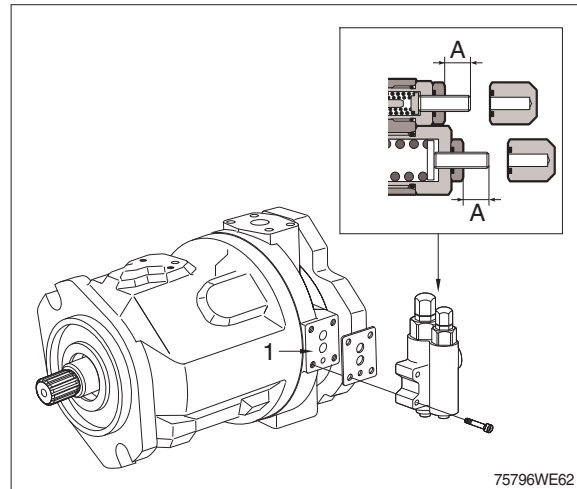

5) DISASSEMBLE THE PUMP

- (1) Remove the control valve.

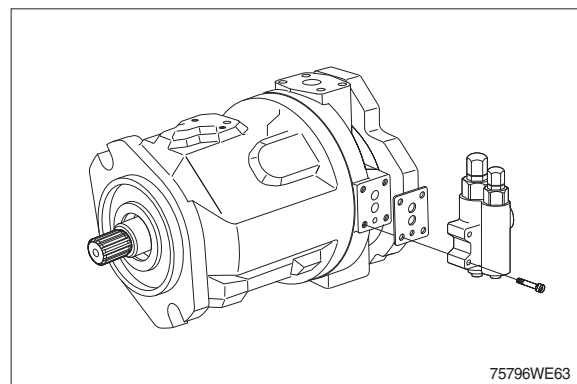

- (2) Mark the location of the connection plate on the housing.

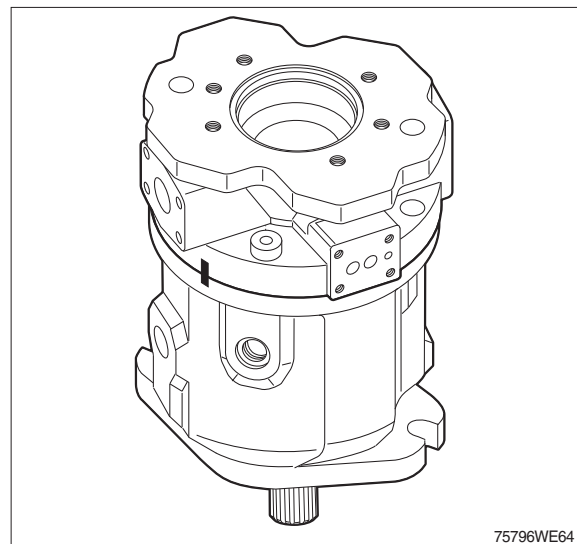

- (3) Remove the connection plate fixing bolts and the connection plate.
※ Distributor plate and adjustment piston can drop down.

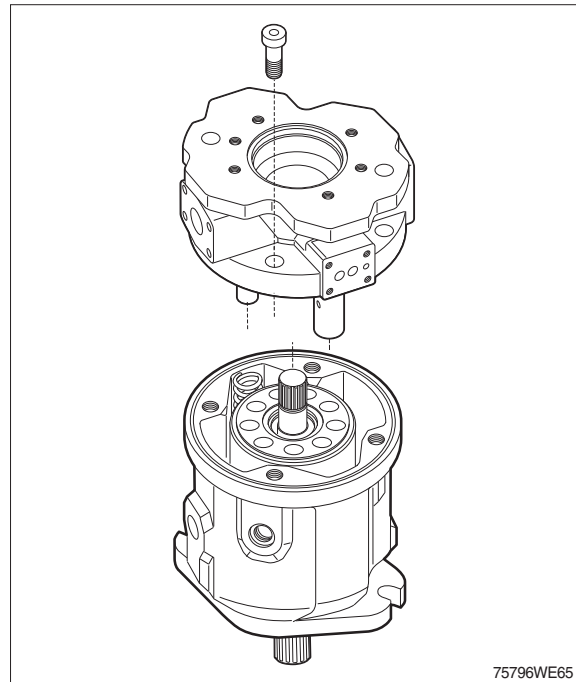

- (4) Remove distributor plate.
Take note of the orientation.
※ Remove bearing with withdrawal tool.
Do not damage the sealing surface.

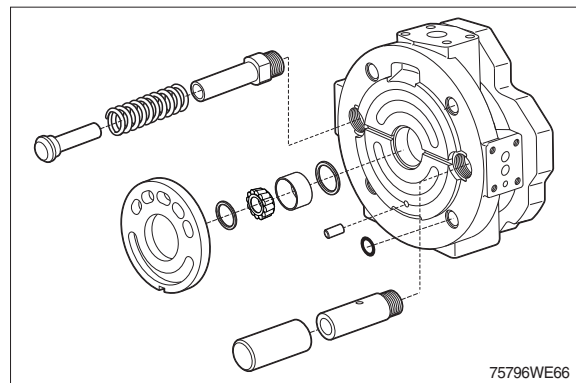

- (5) Remove the rotary group in a horizontal position.

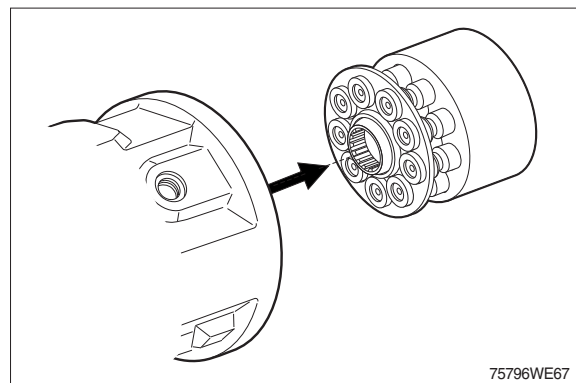

(6) Remove swash plate and bearing shells.

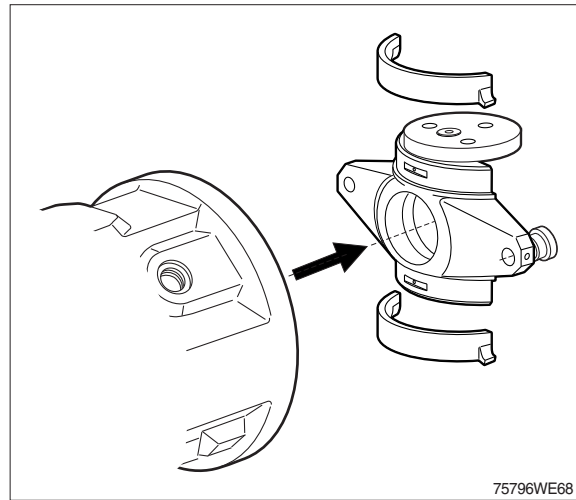

75796WE68

(7) Remove the circlip and the shaft seal.

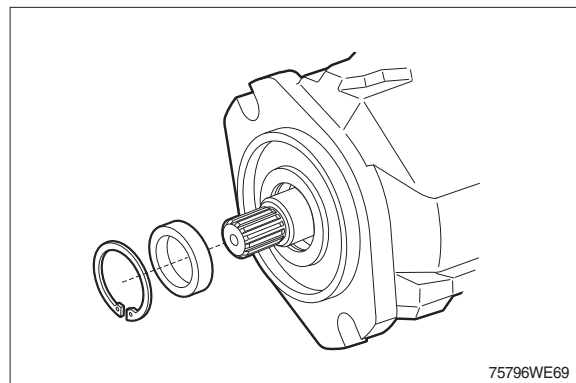

75796WE69

(8) Remove the drive shaft through rear side.

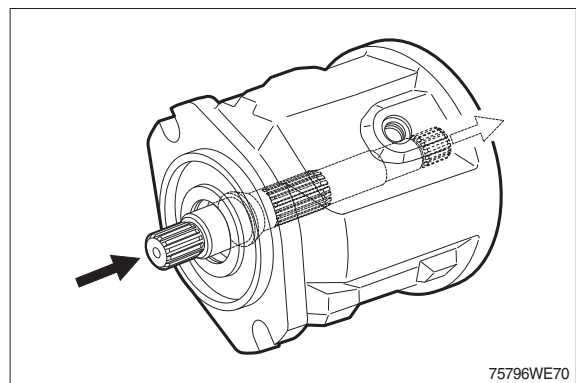

75796WE70

(9) Pre-tension the spring (1) using a suitable device.
Remove circlip (2).
Remove spring (1) and pressure pins (3).

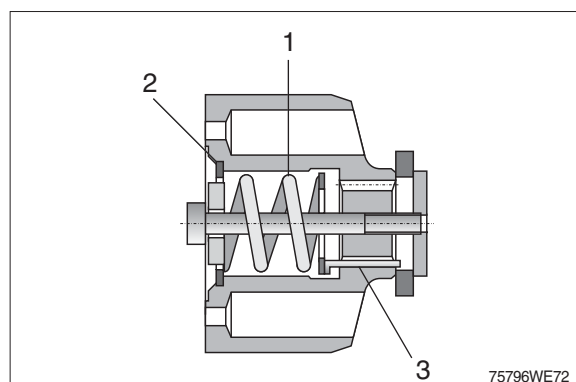

75796WE72

- (10) Use bearing puller to remove outer bearing race of front bearing out of housing press seat.

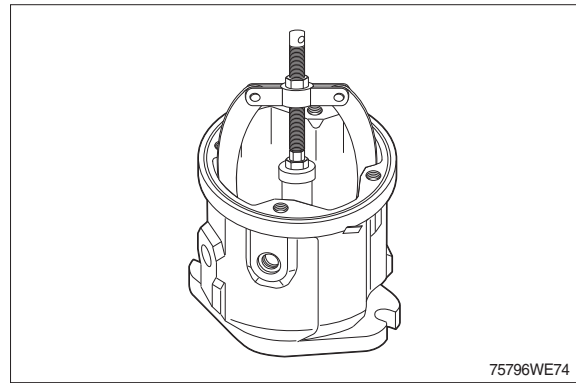

- (11) Remove the control plate.

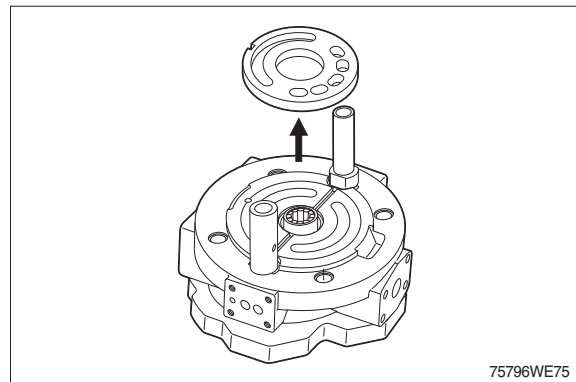

- (12) Use bearing puller to remove outer bearing race of rear bearing - press seat.

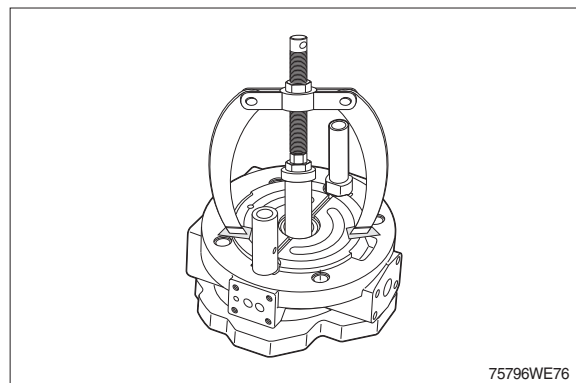

- (13) Disassemble the guide of control piston (Mounting position: pilot valve side).

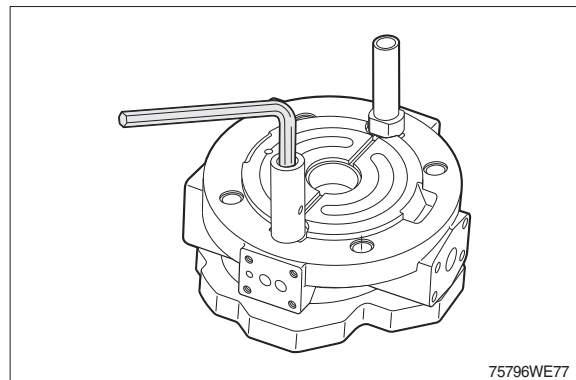

(14) Disassemble the guide of the opposite piston.

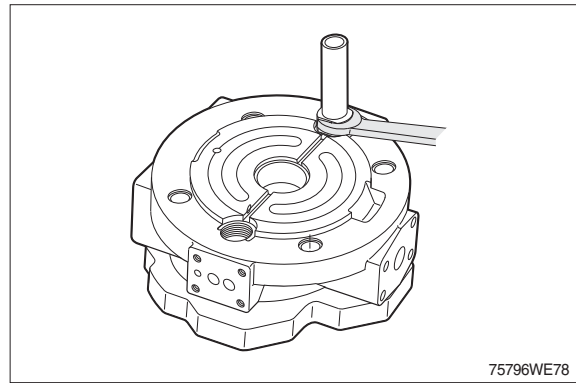

6) INSPECT HINTS

(1) Renew all bearings.

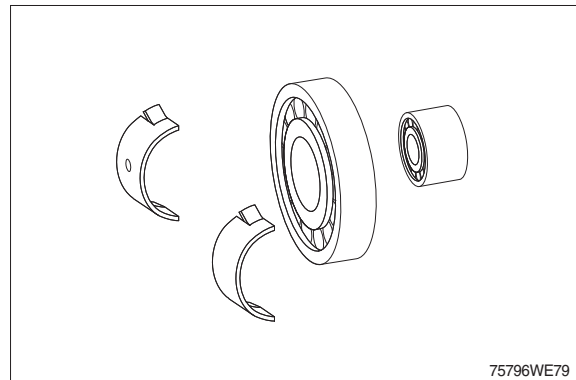

(2) Check :

- 1 Wear on splines, rust
- 2 Drive shaft seal wear grooves
- 3 Bearing seat
- 4 Splines for cylinder drive
- 5 Bearing seat

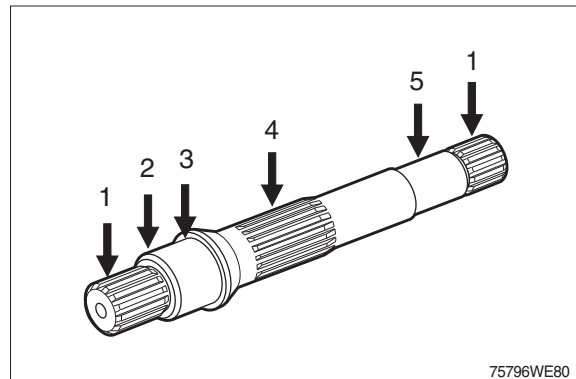

(3) Check :

Sliding surface free of grooves.

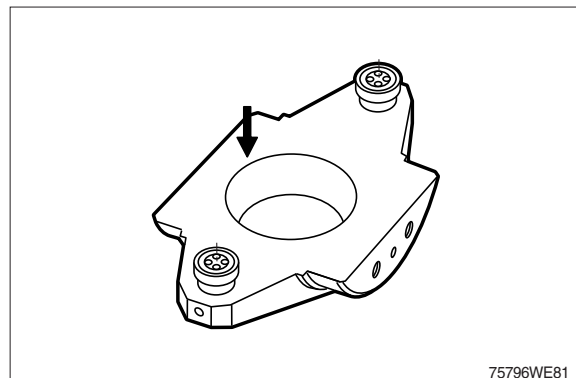

- (4) Check :
Bearing surfaces.

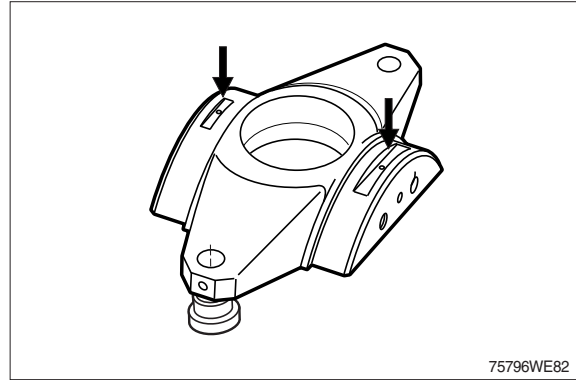

- (5) Check :
That the retaining plate is free of grooves
and that there is no wear in the slipper
pad area.

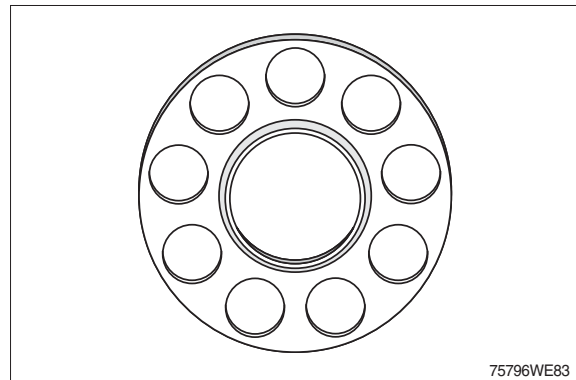

- (6) Check :
Check to see that there are no scratches
or metal deposits on the sliding surface
(1) and that there is no axial play (2)
(Pistons must only be replaced as a set).

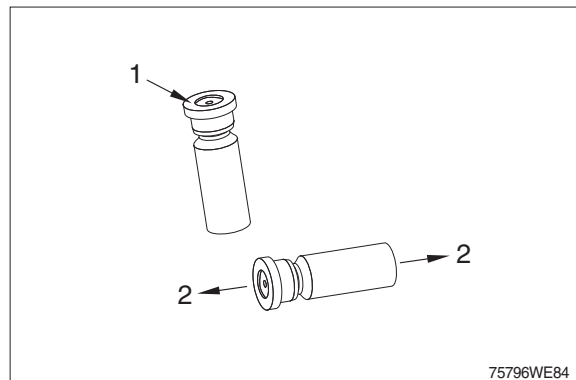

- (7) Check :
1 Cylinder bores
2 Splines

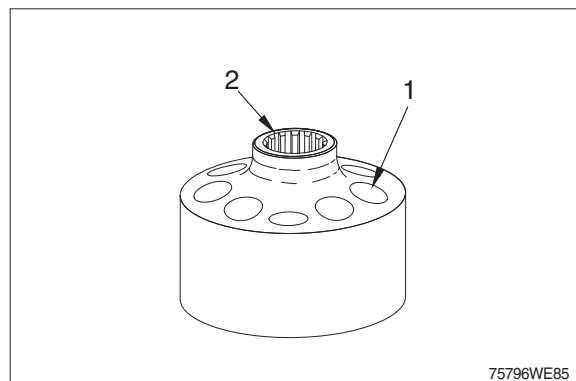

(8) Free of grooves, no signs of wear.

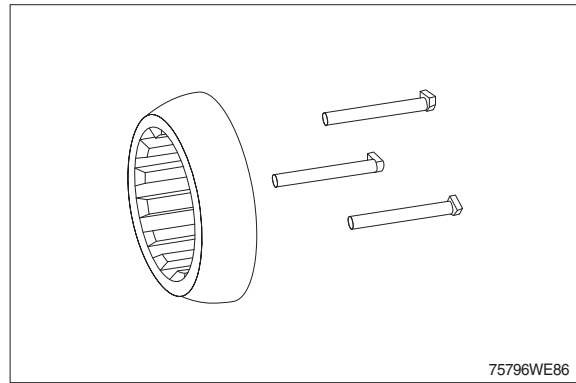

(9) Check :
Cylinder sliding surface free of grooves,
no wear, no embedded foreign particles.
That there are no scratches on the control
plate. (Only replace them as a set).

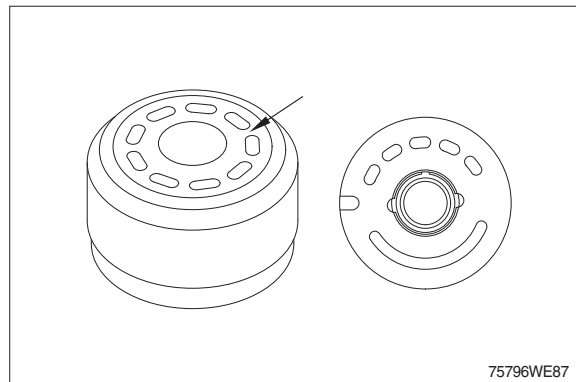

(10) Check :
Mounting surface - control plate
undamaged.

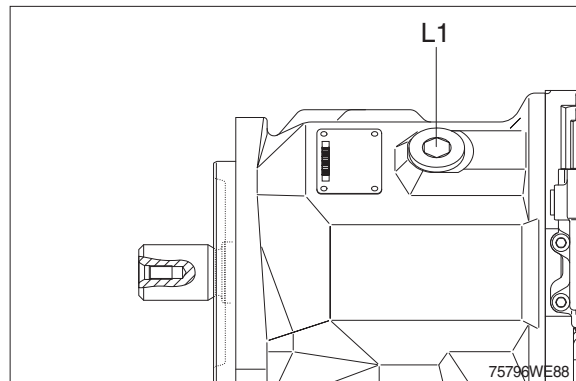

(11) Check :
Check running conditions of the control
piston.

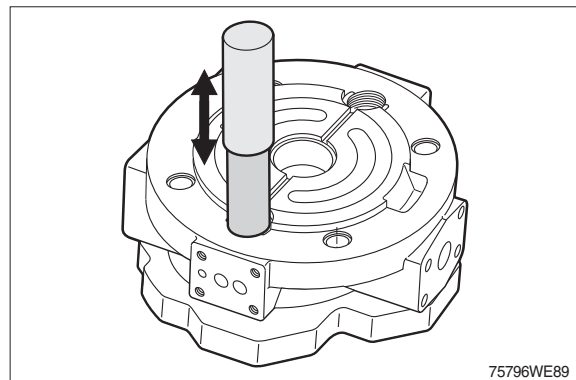

- (12) Check :
Check running conditions of the opposite piston.

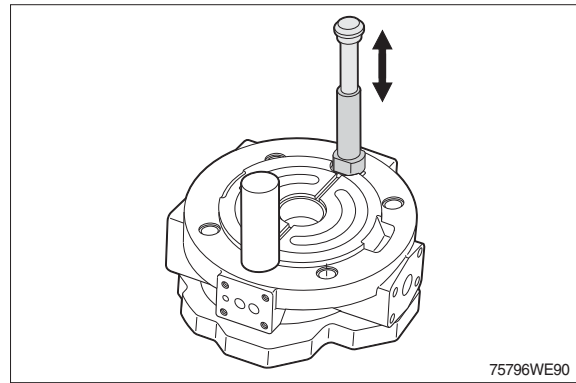

7) ADJUSTMENT OF TAPER ROLLER BEARING SET

- (1) Cast iron housing must have initial tension of the bearings: 0~0,05 mm, grind position A if necessary.

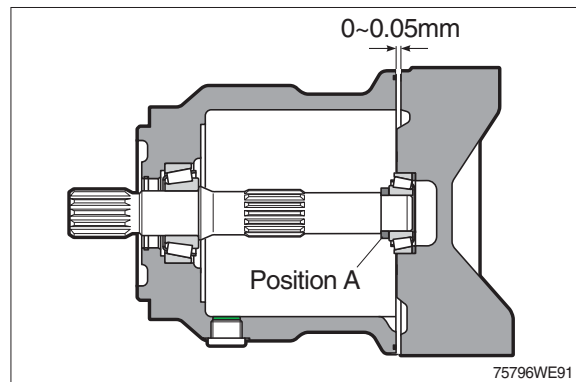

8) PUMP ASSEMBLY

- (1) Fit the seal into the housing.
Fit the circlip.

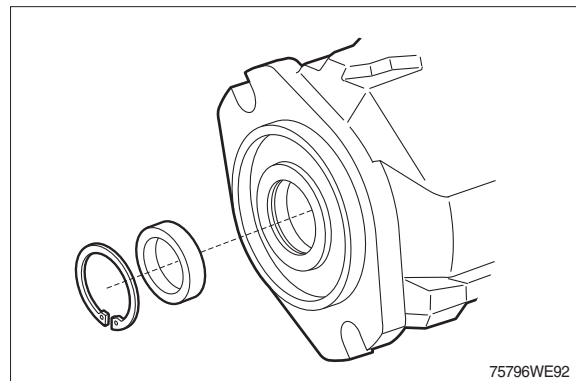

- (2) Fit the drive with bearing from rear end.
※ Do not touch seal lip with edge of keyway or spline.

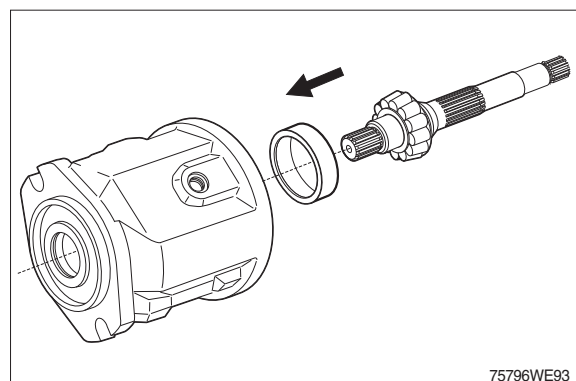

(3) Fit pressure pins using an assembly aid.

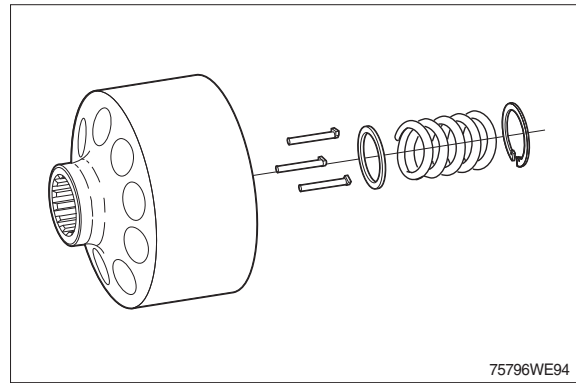

(4) Pre-tension the spring using a suitable device.

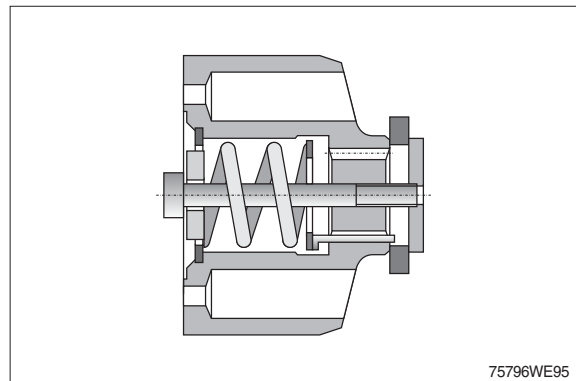

(5) Assemble piston with retaining plate.
※ Oil piston and slipper pad.

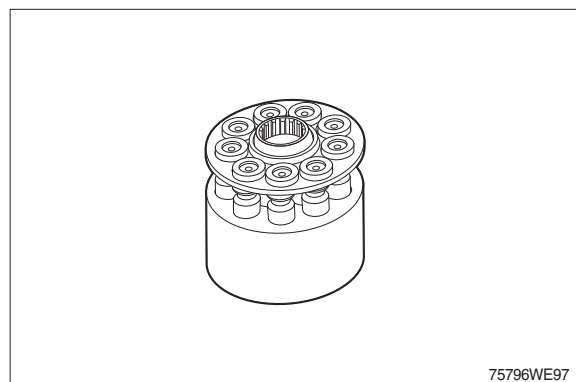

- (6) Fit rotary group.
 ※ Hold the piston by using an O-ring.
 Fit O-ring (1).

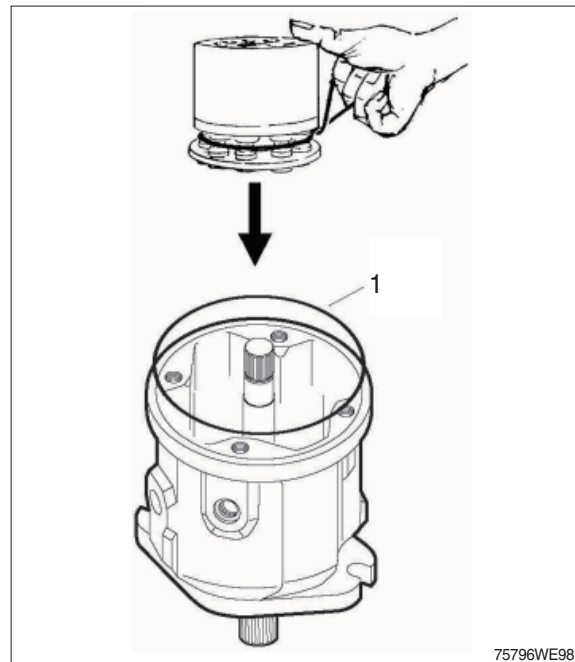

- (7) Fit bearing (1) in connection plate.
 Fit cylindrical pin (2).
 Fit O-rings (3) 4 pieces.
 Fit adjustment spool (4) and guide piston (4a).
 Fit distributor plate (5) (direction of rotation dependent)
 ※ Assembly.
 Hold the components in place with grease.

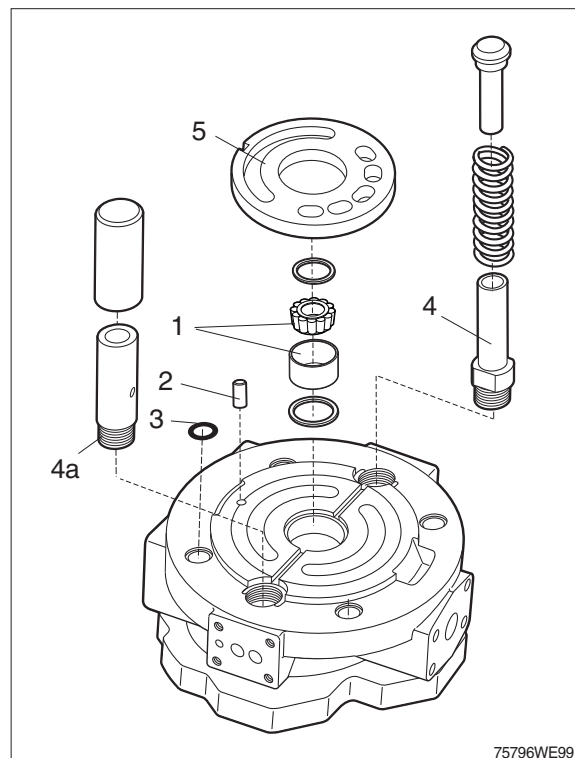

- (8) Fit distributor plate.
※ Assembly aid : Grease

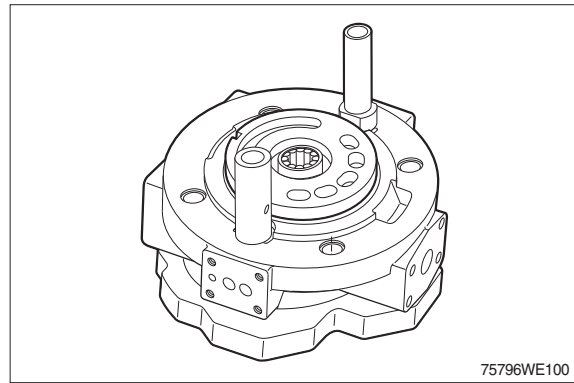

- (9) For clockwise rotation pumps the distributor plate is off-set by 4° to the right from the centre position.
(Clockwise and anti-clockwise rotation distributor plates are not identical).

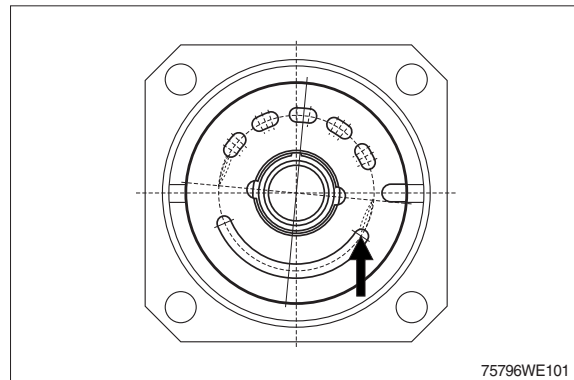

- (10) Fit connection plate and control valve.

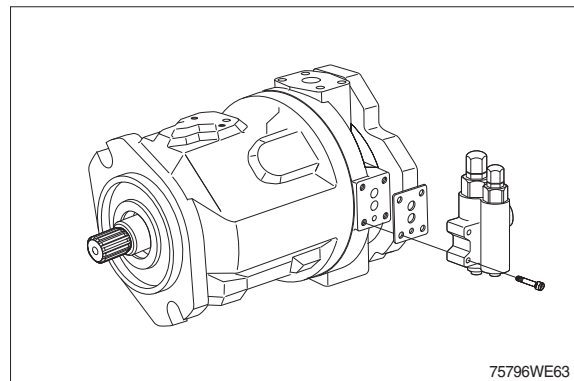

2. MAIN CONTROL VALVE

1) STRUCTURE (1/2)

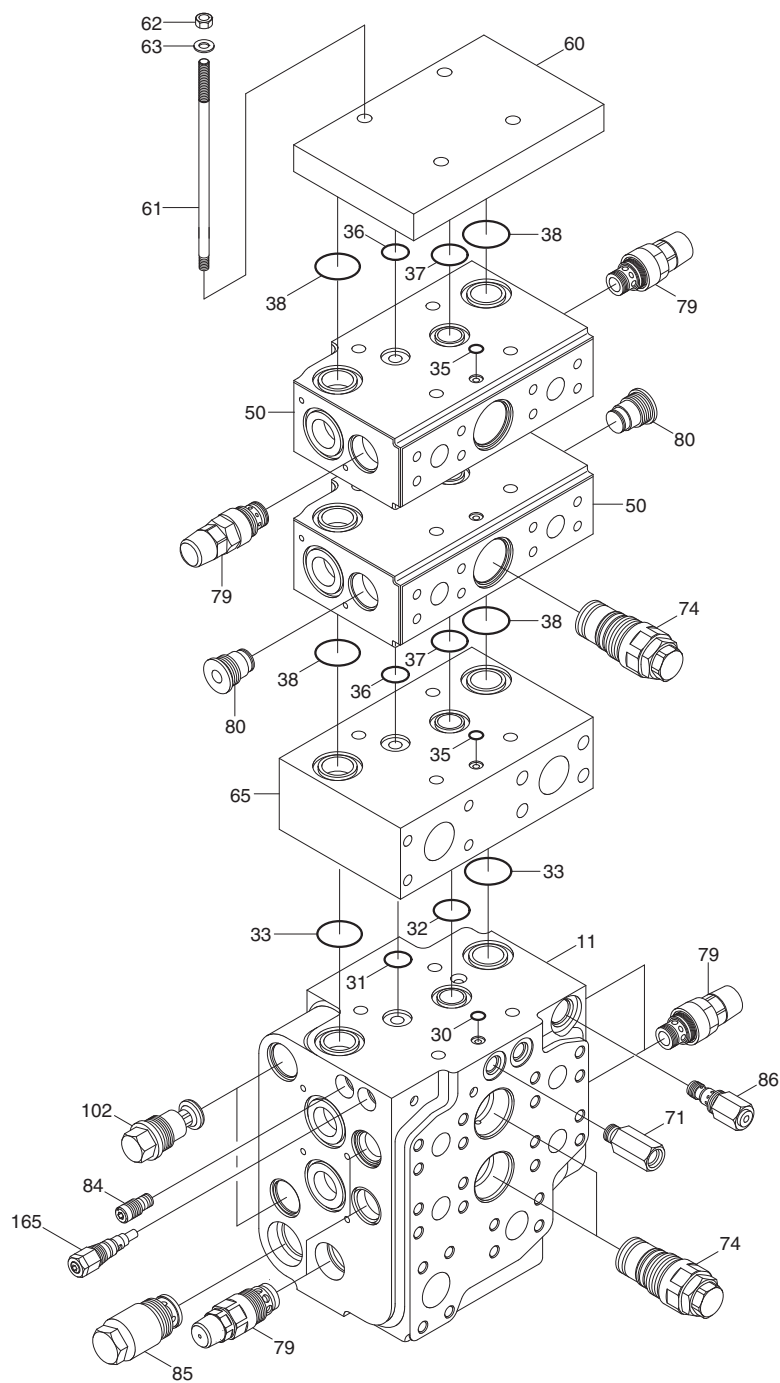

78096WE13

11	Housing	38	O-ring	74	Compensator valve
30	O-ring	50	Housing	79	Pressure valve
31	O-ring	60	Plate	80	Plug screw
32	O-ring	61	Stud	84	Flow regulator
33	O-ring	62	Hexagon nut	85	Precharge valve
35	O-ring	63	Washer	86	Pressure reducing valve
36	O-ring	65	Sandwich plate	102	Locking screw
37	O-ring	71	Shuttle valve	165	Pressure relief valve

STRUCTURE (2/2)

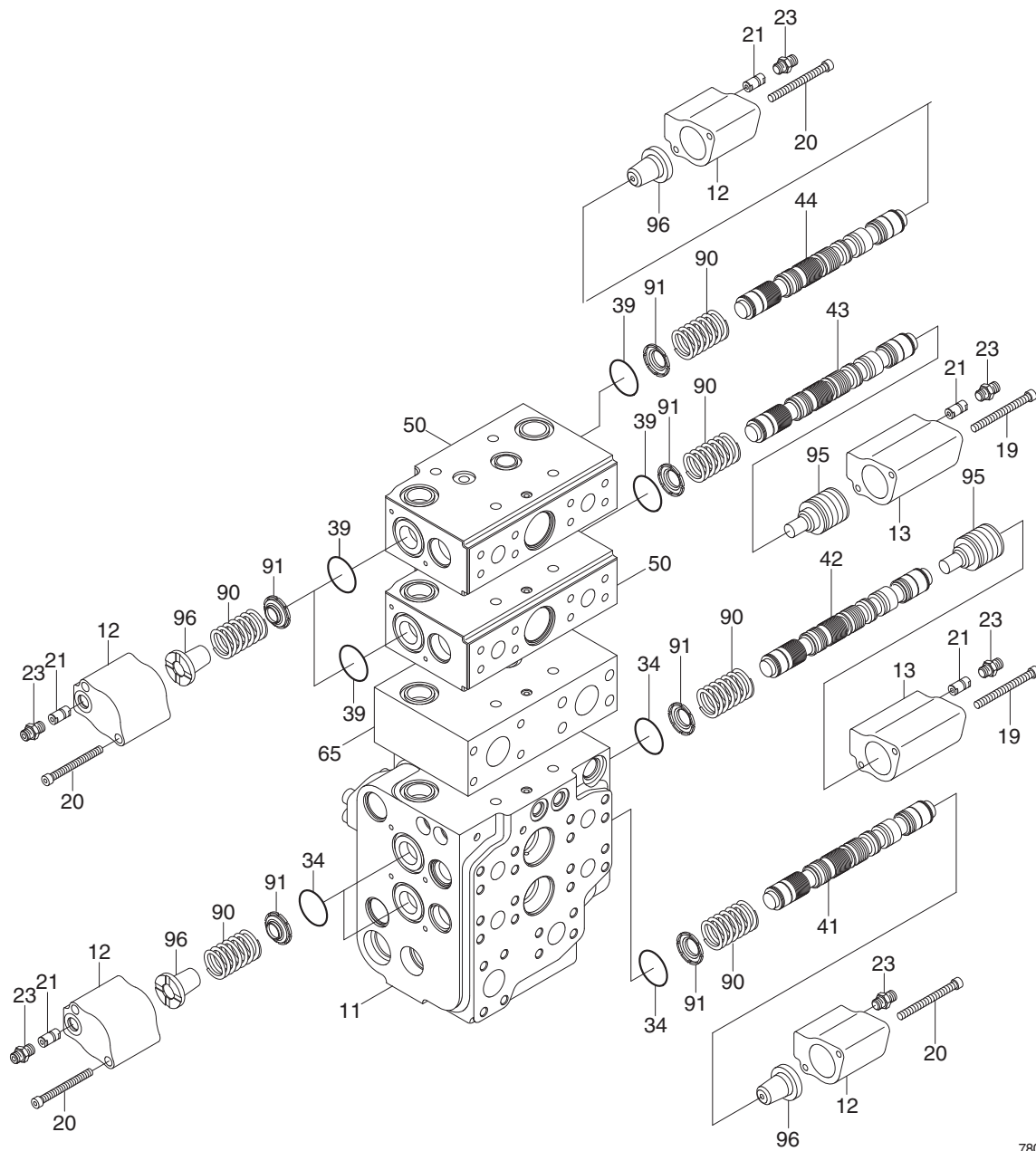

78096WE14

11	Housing	34	O-ring	65	Sandwich plate
12	Cover	39	O-ring	90	Compression spring
13	Cover	41	Spool	91	Spring retainer
19	Bolt	42	Spool	95	Spring retainer
20	Bolt	43	Spool	96	Spring retainer
21	Throttle check valve	44	Spool		
23	Threaded steel pipe fitting	50	Housing		

2) GENERAL PRECAUTIONS

- (1) Clean room with no dust is recommended for maintenance. Because hydraulic components are precision, and have minute clearance. Tool and wash-oil must be clean, too. Handle them carefully.
- (2) At removing control valve from the machine, wash around the piping port, and neither dust nor water should go into inside with plugging. It is same at attaching the machine.
- (3) Prepare the required parts by checking structure figure before assembly. There are parts which are supplied with only sub-assembly part, so check the parts list before assembly.

3) PRECAUTIONS FOR DISASSEMBLY

- (1) Handle the components carefully not to drop them or bump them with each other as they are made with precision.
- (2) Do not force the work by hitting or twisting as burred or damaged component may not be assembled or result in oil leakage or low performance.
- (3) When disassembled, tag the components for identification so that they can be reassembled correctly.
- (4) Once disassembled, O-ring and back-up rings are usually not to be used again.(Remove them using a wire with its end made like a shoe-horn. Be careful not to damage the slot)
- (5) If the components are left disassembled or half-disassembled, they may get rust from moisture or dust. If the work has to be interrupted, take care to prevent rust and dust.

4) PRECAUTIONS FOR REASSEMBLY

- (1) Take the same precautions as for disassembly.
- (2) When assembling the components, remove any metal chips or foreign objects and check them for any burrs or dents. Remove burrs and dents with oil-stone, if any.
- (3) O-rings and back-up rings are to be replaced with new ones, as a rule.
- (4) When installing O-rings and back-up rings, be careful not to damage them. (Apply a little amount of grease for smoothness)
- (5) Tighten the bolts and caps with specified torque.

5) DISASSEMBLY AND ASSEMBLY

(1) Spool

- ① Loosen the bolt (2EA).
 - Tool : Wrench 5 mm
 - Tightening torque : 0.85 kgf · m
(6.1 lbf · ft)

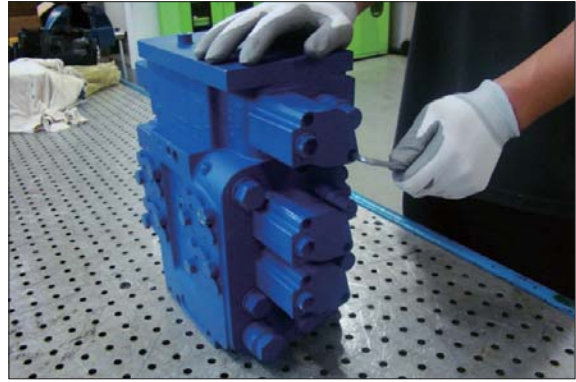

76096WE40

- ② Remove the cover, spring retainer, spring and spool.

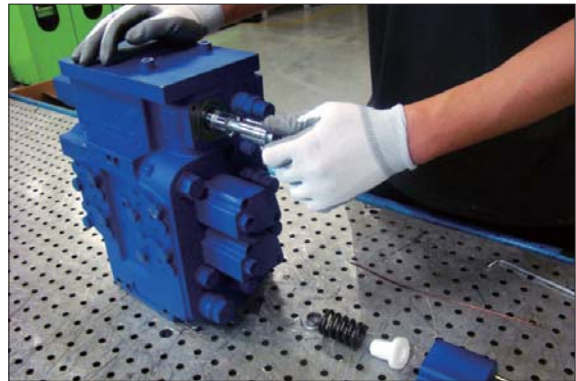

76096WE41

- 1 Spring
- 2 Spring retainer
- 3 Spool
- 4 Cover
- 5 Bolt

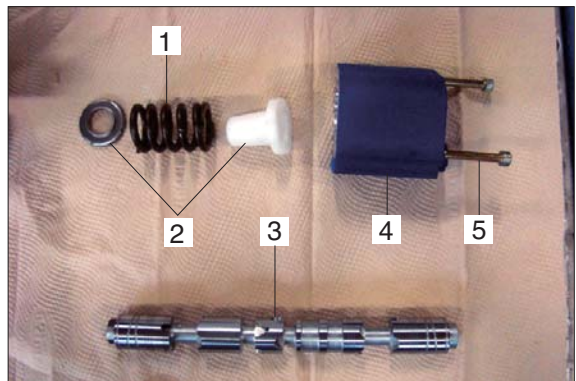

76096WE42

(2) Compensator valve

- Tool : Spanner 42 mm

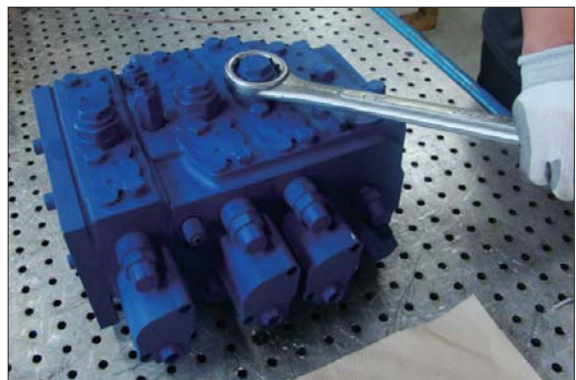

76096WE43

- Tightening torque : 20.4 kgf · m
(148 lbf · ft)

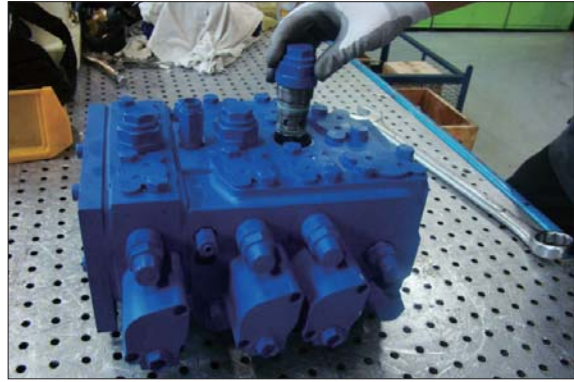

76096WE44

(3) Port relief valve

- Tool : Spanner 30 mm

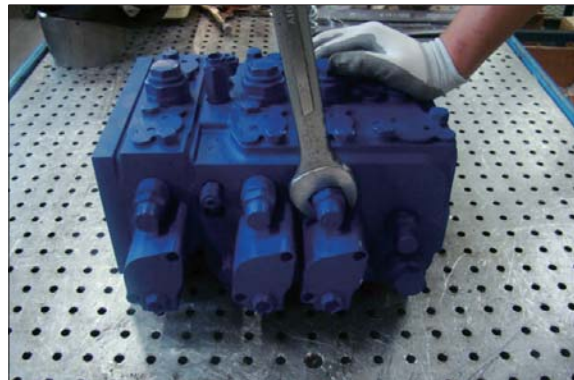

76096WE45

- Tightening torque : 10.2 kgf · m
(73.8 lbf · ft)

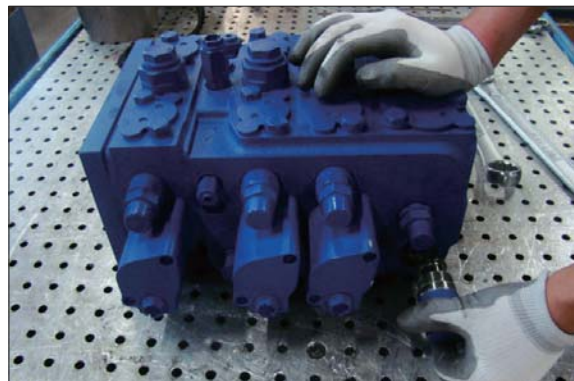

76096WE46

(4) Precharge valve

- Tool : Spanner 32 mm



76096WE47

- Tightening torque : 6.1 kgf · m
(44.3 lbf · ft)

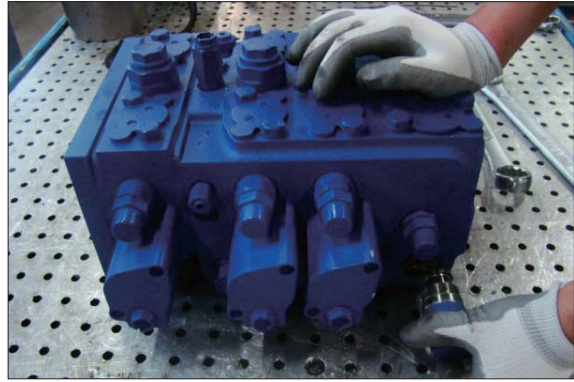

76096WE48

(5) Shuttle valve

- Tool : Spanner 22 mm



76096WE49

- Tightening torque : 3.6 kgf · m
(25.8 lbf · ft)

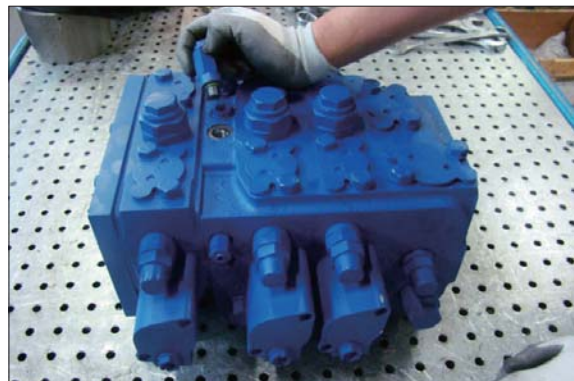

76096WE50