

SECTION 1 GENERAL

Group 1 Safety Hints	1-1
Group 2 Specifications	1-10
Group 3 Operational Checkout Record Sheet	1-23

SECTION 1 GENERAL

GROUP 1 SAFETY HINTS

FOLLOW SAFE PROCEDURE

Unsafe work practices are dangerous. Understand service procedure before doing work; Do not attempt shortcuts.

WEAR PROTECTIVE CLOTHING

Wear close fitting clothing and safety equipment appropriate to the job.

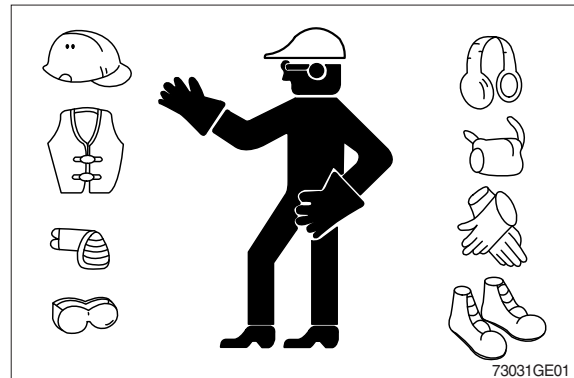

WARN OTHERS OF SERVICE WORK

Unexpected machine movement can cause serious injury.

Before performing any work on the wheel loader, attach a 「Do Not Operate」 tag on the right side controller lever.

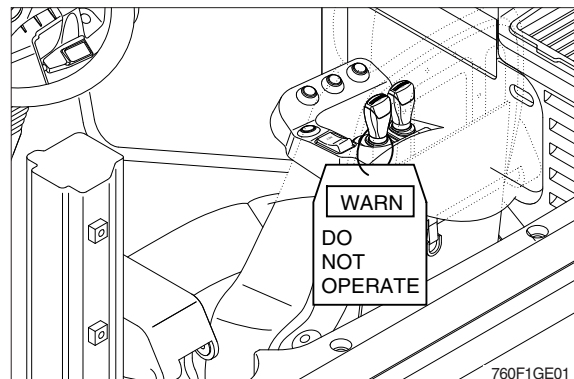

USE HANDHOLDS AND STEPS

Falling is one of the major causes of personal injury.

When you get on and off the machine, always maintain a three point contact with the steps and handrails and face the machine. Do not use any controls as handholds.

Never jump on or off the machine. Never mount or dismount a moving machine.

Be careful of slippery conditions on platforms, steps, and handrails when leaving the machine.

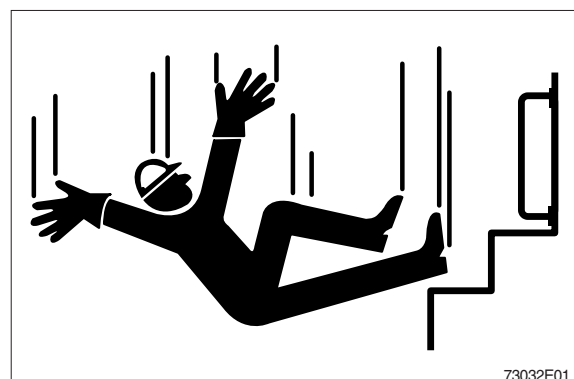

PREPARE FOR EMERGENCIES

Be prepared if a fire starts.

Keep a first aid kit and fire extinguisher handy.

Keep emergency numbers for doctors, ambulance service, hospital, and fire department near your telephone.

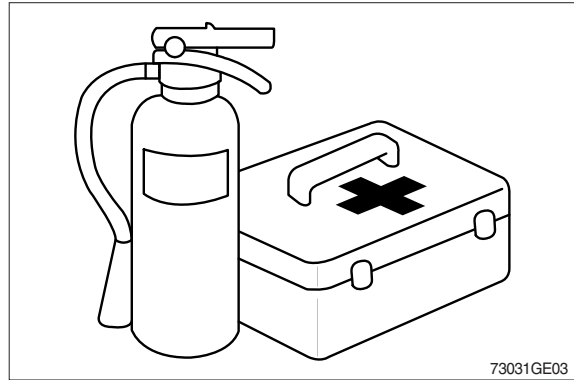

WORK IN CLEAN AREA

Before starting a job :

- Clean work area and machine.
- Make sure you have all necessary tools to do your job.
- Have the right parts on hand.
- Read all instructions thoroughly; Do not attempt shortcuts.

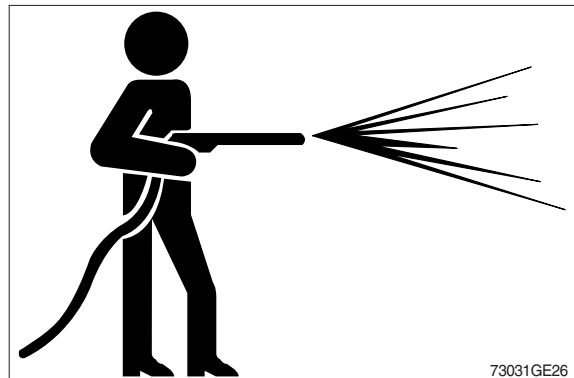

PROTECT AGAINST FLYING DEBRIS

Guard against injury from flying pieces of metal or debris; Wear goggles or safety glasses.

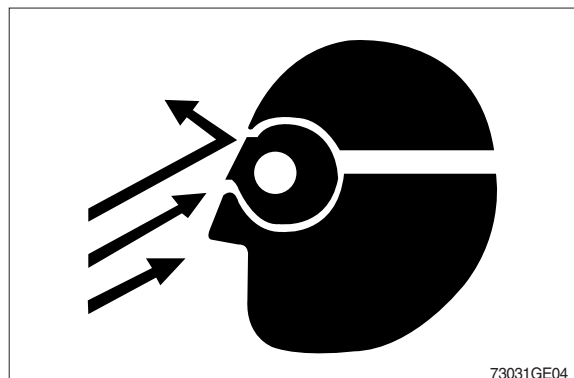

PROTECT AGAINST NOISE

Prolonged exposure to loud noise can cause impairment or loss of hearing.

Wear a suitable hearing protective device such as earmuffs or earplugs to protect against objectionable or uncomfortable loud noises.

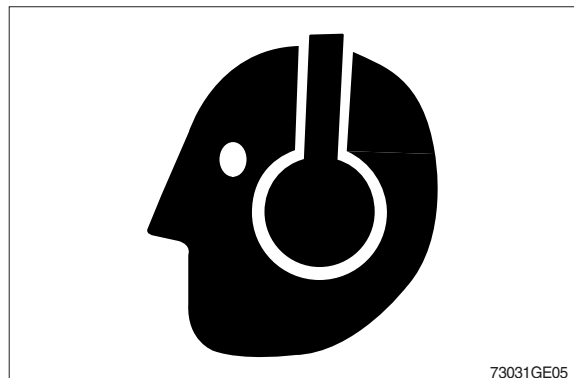

PARK MACHINE SAFELY

Before working on the machine:

- Park machine on a level surface.
- Lower bucket to the ground.
- Turn key switch to OFF to stop engine. Remove key from switch.
- Move pilot control shutoff lever to locked position.
- Allow engine to cool.

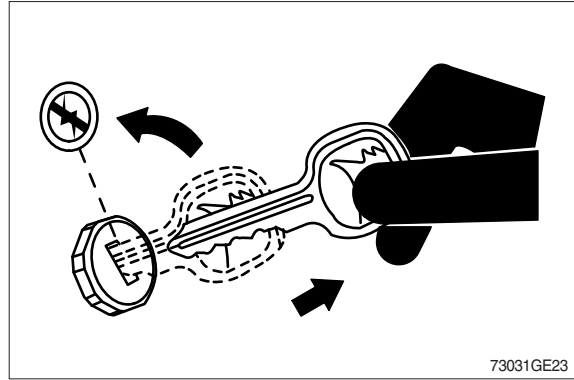

SUPPORT MACHINE PROPERLY

Always lower the attachment or implement to the ground before you work on the machine. If you must work on a lifted machine or attachment, securely support the machine or attachment.

Do not support the machine on cinder blocks, hollow tiles, or props that may crumble under continuous load.

Do not work under a machine that is supported solely by a jack.

Follow recommended procedures in this manual.



SERVICE COOLING SYSTEM SAFELY

Explosive release of fluids from pressurized cooling system can cause serious burns.

Shut off engine.

Only remove filler cap when cool enough to touch with bare hands.

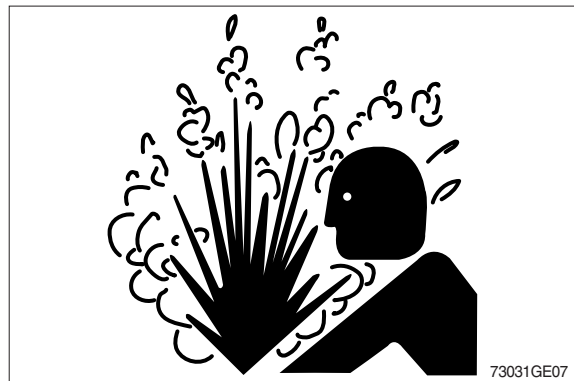

HANDLE FLUIDS SAFELY-AVOID FIRES

Handle fuel with care; It is highly flammable. Do not refuel the machine while smoking or when near open flame or sparks. Always stop engine before refueling machine.

Fill fuel tank outdoors.

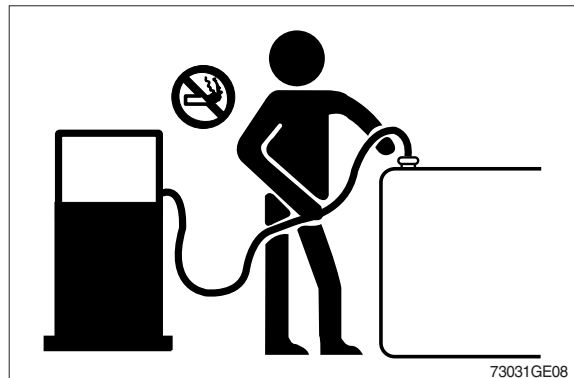

Store flammable fluids away from fire hazards. Do not incinerate or puncture pressurized containers.

Make sure machine is clean of trash, grease, and debris.

Do not store oily rags ; They can ignite and burn spontaneously.

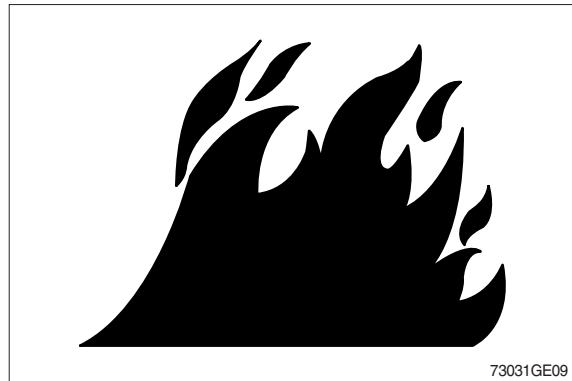

BEWARE OF EXHAUST FUMES

Prevent asphyxiation. Engine exhaust fumes can cause sickness or death.

If you must operate in a building, be positive there is adequate ventilation. Either use an exhaust pipe extension to remove the exhaust fumes or open doors and windows to bring enough outside air into the area.

REMOVE PAINT BEFORE WELDING OR HEATING

Avoid potentially toxic fumes and dust.

Hazardous fumes can be generated when paint is heated by welding, soldering, or using a torch.

Do all work outside or in a well ventilated area. Dispose of paint and solvent properly.

Remove paint before welding or heating:

- If you sand or grind paint, avoid breathing the dust. Wear an approved respirator.
- If you use solvent or paint stripper, remove stripper with soap and water before welding. Remove solvent or paint stripper containers and other flammable material from area. Allow fumes to disperse at least 15 minutes before welding or heating.

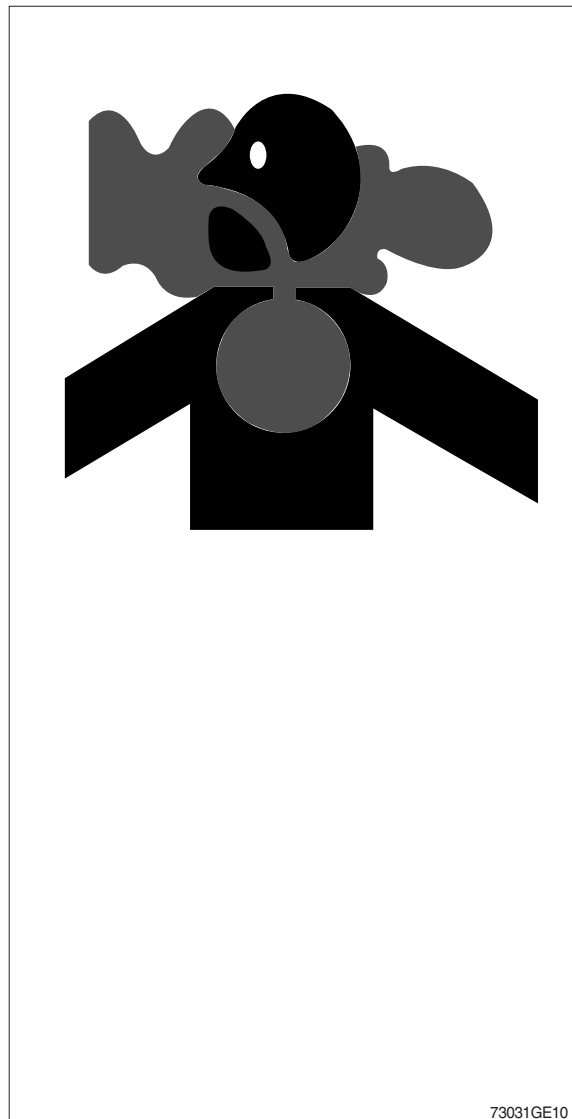

ILLUMINATE WORK AREA SAFELY

Illuminate your work area adequately but safely. Use a portable safety light for working inside or under the machine. Make sure the bulb is enclosed by a wire cage. The hot filament of an accidentally broken bulb can ignite spilled fuel or oil.

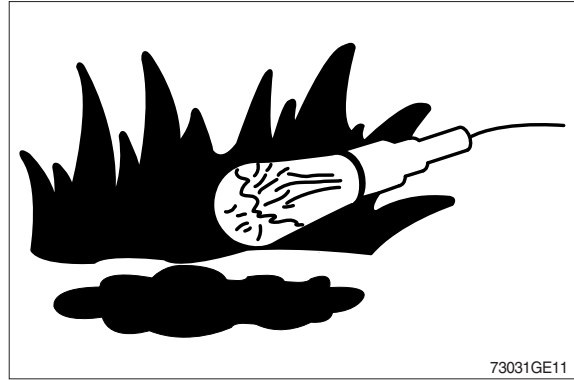

SERVICE MACHINE SAFELY

Tie long hair behind your head. Do not wear a necktie, scarf, loose clothing or necklace when you work near machine tools or moving parts. If these items were to get caught, severe injury could result.

Remove rings and other jewelry to prevent electrical shorts and entanglement in moving parts.

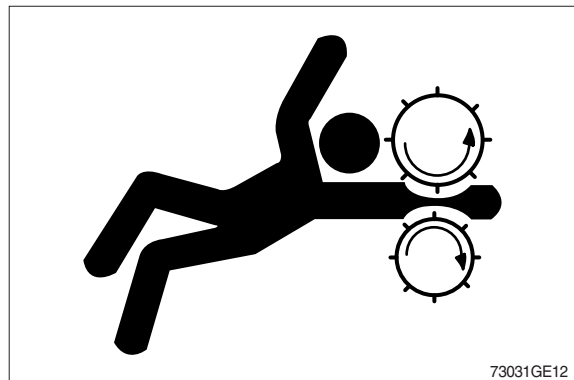

STAY CLEAR OF MOVING PARTS

Entanglements in moving parts can cause serious injury.

To prevent accidents, use care when working around rotating parts.

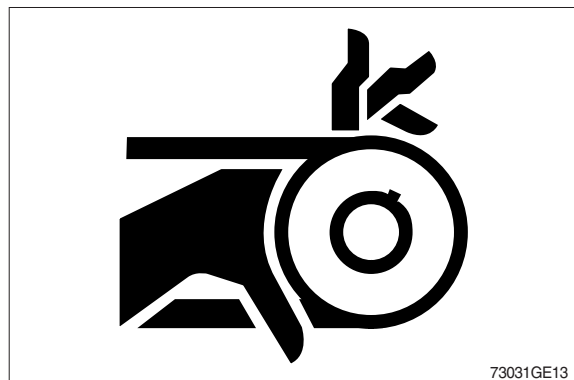

AVOID HIGH PRESSURE FLUIDS

Escaping fluid under pressure can penetrate the skin causing serious injury.

Avoid the hazard by relieving pressure before disconnecting hydraulic or other lines. Tighten all connections before applying pressure.

Search for leaks with a piece of cardboard. Protect hands and body from high pressure fluids.

If an accident occurs, see a doctor immediately. Any fluid injected into the skin must be surgically removed within a few hours or gangrene may result.

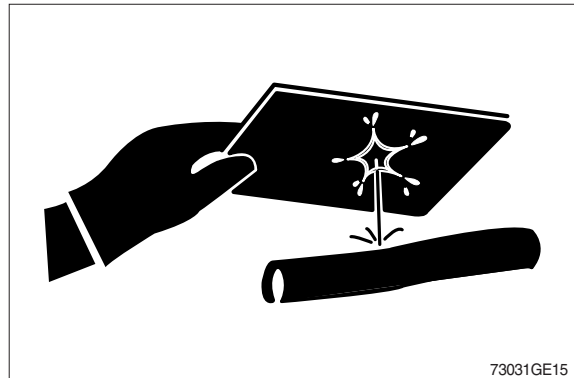

AVOID HEATING NEAR PRESSURIZED FLUID LINES

Flammable spray can be generated by heating near pressurized fluid lines, resulting in severe burns to yourself and bystanders. Do not heat by welding, soldering, or using a torch near pressurized fluid lines or other flammable materials.

Pressurized lines can be accidentally cut when heat goes beyond the immediate flame area. Install fire resisting guards to protect hoses or other materials.



PREVENT BATTERY EXPLOSIONS

Keep sparks, lighted matches, and flame away from the top of battery. Battery gas can explode.

Never check battery charge by placing a metal object across the posts. Use a volt-meter or hydrometer.

Do not charge a frozen battery; It may explode. Warm battery to 16°C (60°F).



PREVENT ACID BURNS

Sulfuric acid in battery electrolyte is poisonous. It is strong enough to burn skin, eat holes in clothing, and cause blindness if splashed into eyes.

Avoid the hazard by:

1. Filling batteries in a well-ventilated area.
2. Wearing eye protection and rubber gloves.
3. Avoiding breathing fumes when electrolyte is added.
4. Avoiding spilling or dripping electrolyte.
5. Use proper jump start procedure.

If you spill acid on yourself:

1. Flush your skin with water.
2. Apply baking soda or lime to help neutralize the acid.
3. Flush your eyes with water for 10-15 minutes.
Get medical attention immediately.

If acid is swallowed:

1. Drink large amounts of water or milk.
2. Then drink milk of magnesia, beaten eggs, or vegetable oil.
3. Get medical attention immediately.

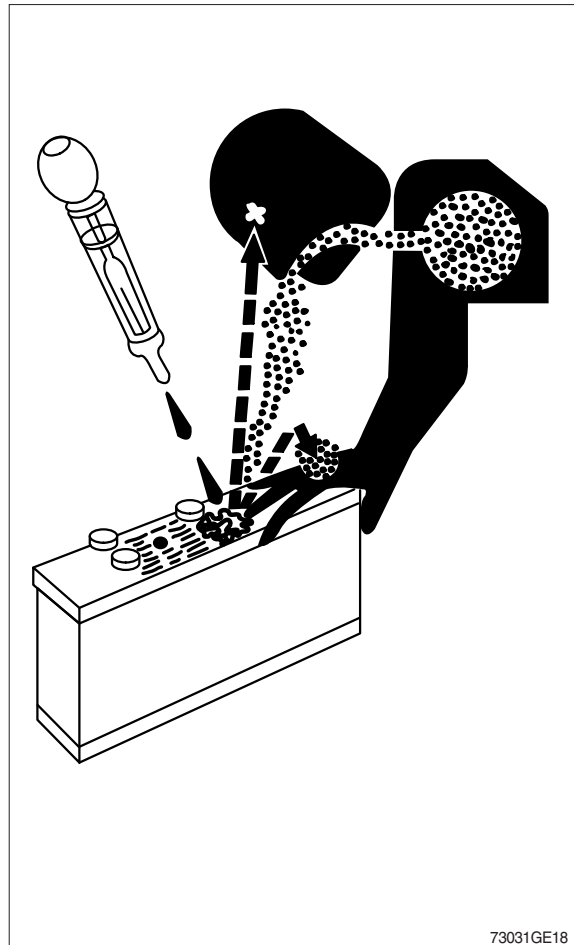

USE TOOLS PROPERLY

Use tools appropriate to the work. Makeshift tools, parts, and procedures can create safety hazards.

Use power tools only to loosen threaded tools and fasteners.

For loosening and tightening hardware, use the correct size tools. Avoid bodily injury caused by slipping wrenches.

Use only recommended replacement parts.
(See Parts catalogue.)

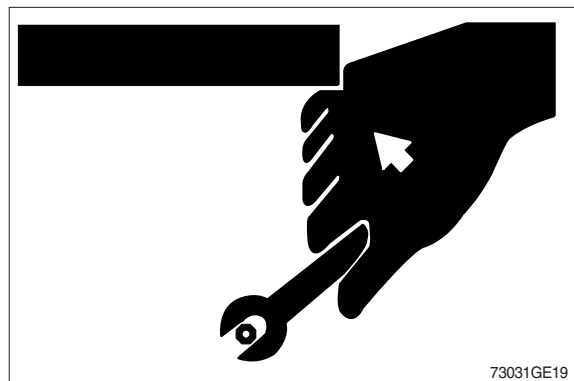

SERVICE TIRES SAFELY

Explosive separation of a tire and rim parts can cause serious injury or death.

Do not attempt to mount a tire unless you have the proper equipment and experience to perform the job.

Always maintain the correct tire pressure. Do not inflate the tires above the recommended pressure. Never weld or heat a wheel and tire assembly. The heat can cause an increase in air pressure resulting in a tire explosion.

Welding can structurally weaken or deform the wheel.

When inflating tires, use a clip-on chuck and extension hose long enough to allow you to stand to one side and not in front of or over the tire assembly. Use a safety cage if available.

Check wheels for low pressure, cuts, bubbles, damaged rims or missing lug bolts and nuts.

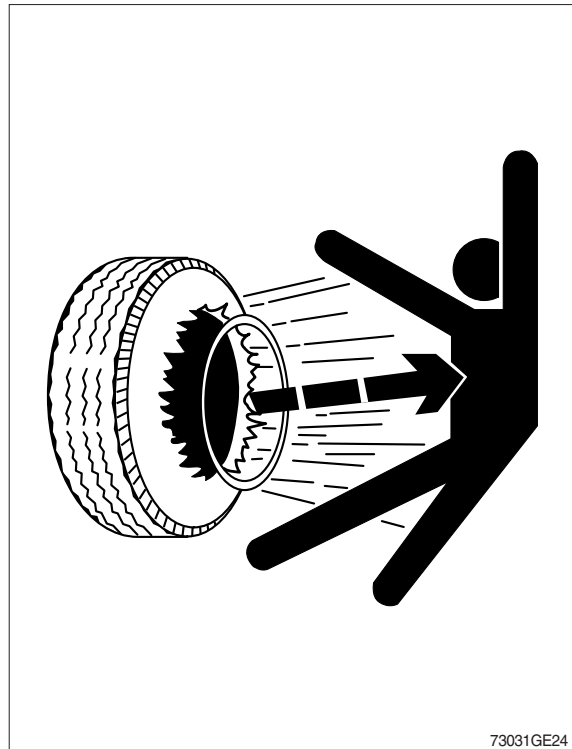

73031GE24

USE PROPER LIFTING EQUIPMENT

Lifting heavy components incorrectly can cause severe injury or machine damage.

Follow recommended procedure for removal and installation of components in the manual.

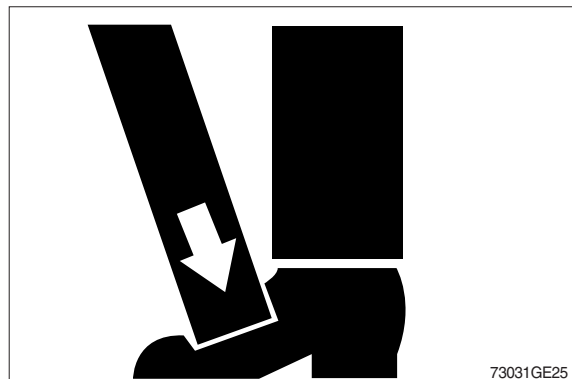

73031GE25

DISPOSE OF FLUIDS PROPERLY

Improperly disposing of fluids can harm the environment and ecology. Before draining any fluids, find out the proper way to dispose of waste from your local environmental agency.

Use proper containers when draining fluids. Do not use food or beverage containers that may mislead someone into drinking from them.

DO NOT pour oil into the ground, down a drain, or into a stream, pond, or lake. Observe relevant environmental protection regulations when disposing of oil, fuel, coolant, brake fluid, filters, batteries, and other harmful waste.

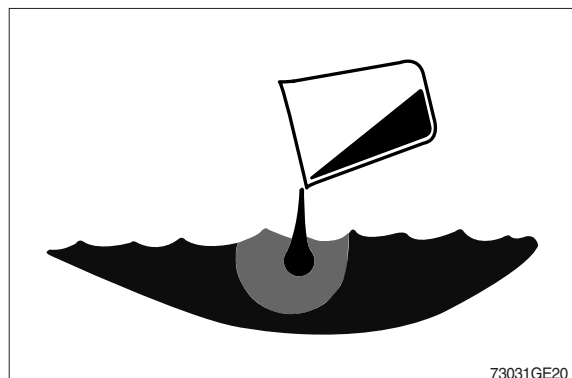

73031GE20

REPLACE SAFETY SIGNS

Replace missing or damaged safety signs. See the machine operator's manual for correct safety sign placement.

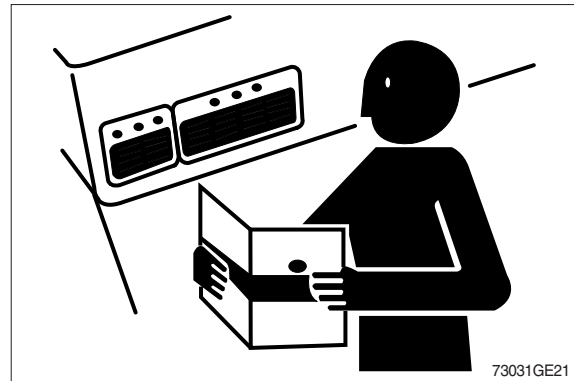

LIVE WITH SAFETY

Before returning machine to customer, make sure machine is functioning properly, especially the safety systems.

Install all guards and shields.

KEEP ROPS INSTALLED PROPERLY

Make certain all parts are reinstalled correctly if the roll-over protective structure (ROPS) is loosened or removed for any reason.

Tighten mounting bolts to proper torque.

The protection offered by ROPS will be impaired if ROPS is subjected to structural damage, is involved in an overturn incident, or is in any way altered by welding, bending, drilling, or cutting.

A damaged ROPS should be replaced, not reused.

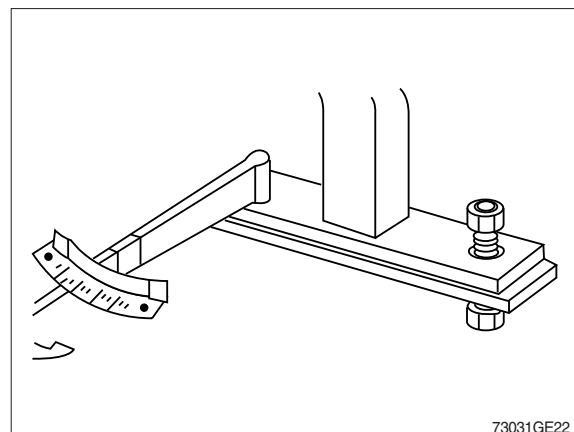

GROUP 2 SPECIFICATIONS

1. MAJOR COMPONENT

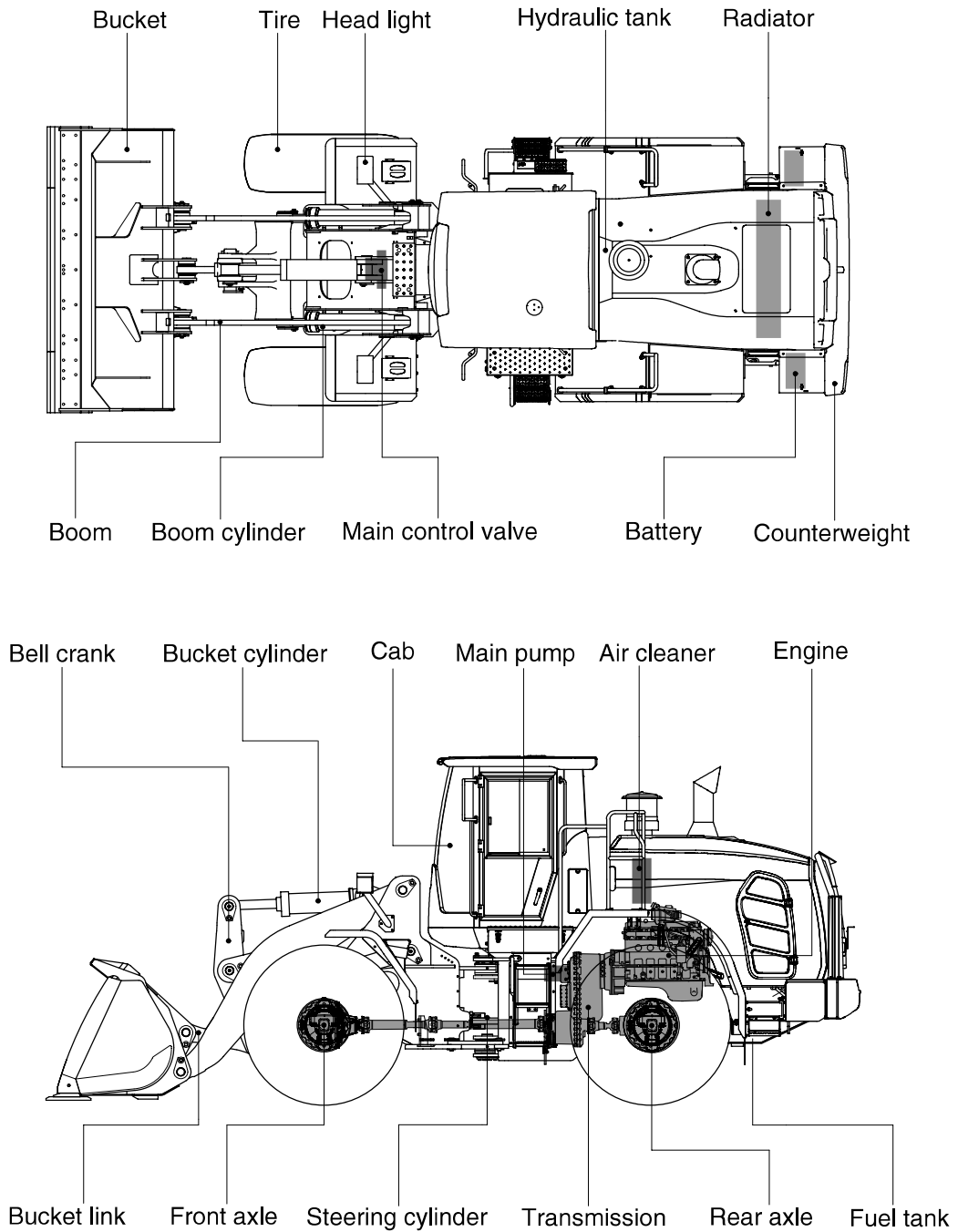

960A2SE01

2. SPECIFICATIONS

1) WITH BOLT-ON CUTTING EDGE TYPE BUCKET (HL960A / HL960A HD)

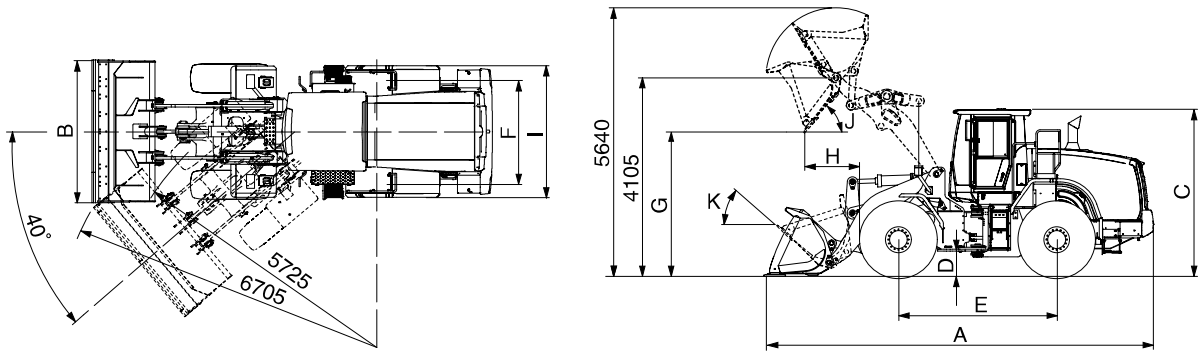

960A2SE03

Description		Unit	Specification	
Operating weight (HL960A / HL960A HD)		kg (lb)	19200 (42330) / 19450 (42880)	
Bucket capacity	Struck	m ³ (yd ³)	2.9 (3.8)	
	Heaped		3.3 (4.3)	
Overall length	A	mm (ft-in)	8140 (26' 8")	
Overall width	B		2900 (9' 6")	
Overall height	C		3450 (11' 4")	
Ground clearance	D		410 (1' 4")	
Wheelbase	E		3300 (10' 10")	
Tread	F		2160 (7' 1")	
Dump clearance at 45°	G		2935 (9' 8")	
Dump reach (full lift)	H		1285 (4' 2")	
Width over tires	I		2770 (9' 1")	
Dump angle	J		degree (°)	50
Roll back angle (carry position)	K			47
Cycle time	Lift (with load)	sec	5.8	
	Dump (with load)		2.0	
	Lower (empty)		3.6	
Maximum travel speed		km/hr (mph)	39.0 (24.2)	
Braking distance		m (ft-in)	13.3 (43' 8")	
Minimum turning radius (center of outside tire)			5.72 (18' 9")	
Gradeability		degree (°)	30	
Breakout force		kg (lb)	16670 (36750)	
Travel speed	Forward	First gear	6.4 (4.0)	
		Second gear	12.1 (7.5)	
		Third gear	24.5 (15.2)	
		Fourth gear	39.0 (24.2)	
	Reverse	First gear	6.8 (4.2)	
		Second gear	12.8 (7.9)	
Third gear		25.7 (15.9)		

WITH BOLT-ON CUTTING EDGE TYPE BUCKET (HL960A XT / HL960A HD XT)

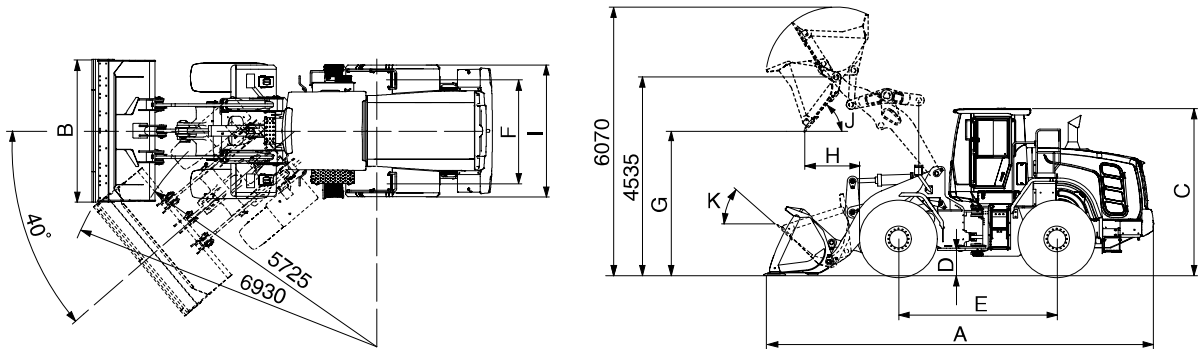

960A2SE03-1

Description		Unit	Specification	
Operating weight (HL960A XT /HL960A HD XT)		kg (lb)	20030 (44160) / 20280 (44710)	
Bucket capacity	Struck	m ³ (yd ³)	2.9 (3.8)	
	Heaped		3.3 (4.3)	
Overall length	A	mm (ft-in)	8695 (28' 6")	
Overall width	B		2900 (9' 6")	
Overall height	C		3450 (11' 4")	
Ground clearance	D		410 (1' 4")	
Wheelbase	E		3300 (10' 10")	
Tread	F		2160 (7' 1")	
Dump clearance at 45°	G		3365 (11' 0")	
Dump reach (full lift)	H		1380 (4' 6")	
Width over tires	I		2770 (9' 1")	
Dump angle	J		degree (°)	50
Roll back angle (carry position)	K			48
Cycle time	Lift (with load)		sec	5.8
	Dump (with load)			2.0
	Lower (empty)	3.6		
Maximum travel speed		km/hr (mph)	39.0 (24.2)	
Braking distance		m (ft-in)	13.3 (43' 8")	
Minimum turning radius (center of outside tire)			5.72 (18' 9")	
Gradeability		degree (°)	30	
Breakout force		kg (lb)	16430 (36220)	
Travel speed	Forward	First gear	6.4 (4.0)	
		Second gear	12.1 (7.5)	
		Third gear	24.5 (15.2)	
		Fourth gear	39.0 (24.2)	
	Reverse	First gear	6.8 (4.2)	
		Second gear	12.8 (7.9)	
Third gear		25.7 (15.9)		

2) WITH TOOTH TYPE BUCKET (HL960A / HL960A HD)

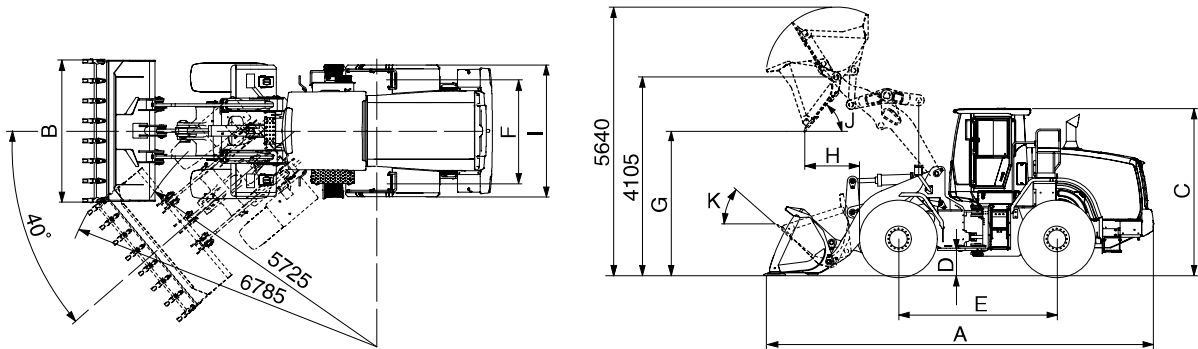

960A2SE02

Description		Unit	Specification	
Operating weight (HL960A / HL960A HD)		kg (lb)	19125 (42160) / 19375 (42710)	
Bucket capacity	Struck	m ³ (yd ³)	2.8 (3.6)	
	Heaped		3.2 (4.2)	
Overall length	A	mm (ft-in)	8290 (27' 2")	
Overall width	B		2950 (9' 8")	
Overall height	C		3450 (11' 4")	
Ground clearance	D		410 (1' 4")	
Wheelbase	E		3300 (10' 10")	
Tread	F		2160 (7' 1")	
Dump clearance at 45°	G		2810 (9' 3")	
Dump reach (full lift)	H		1370 (4' 6")	
Width over tires	I		2770 (9' 1")	
Dump angle	J		degree (°)	50
Roll back angle (carry position)	K			47
Cycle time	Lift (with load)	sec	5.8	
	Dump (with load)		2.0	
	Lower (empty)		3.6	
Maximum travel speed		km/hr (mph)	39.0 (24.2)	
Braking distance		m (ft-in)	13.3 (43' 8")	
Minimum turning radius (center of outside tire)			5.72 (18' 9")	
Gradeability		degree (°)	30	
Breakout force		kg (lb)	17705 (39030)	
Travel speed	Forward	First gear	6.4 (4.0)	
		Second gear	12.1 (7.5)	
		Third gear	24.5 (15.2)	
		Fourth gear	39.0 (24.2)	
	Reverse	First gear	6.8 (4.2)	
		Second gear	12.8 (7.9)	
Third gear		25.7 (15.9)		

WITH TOOTH TYPE BUCKET (HL960 XT / HL960 HD XT)

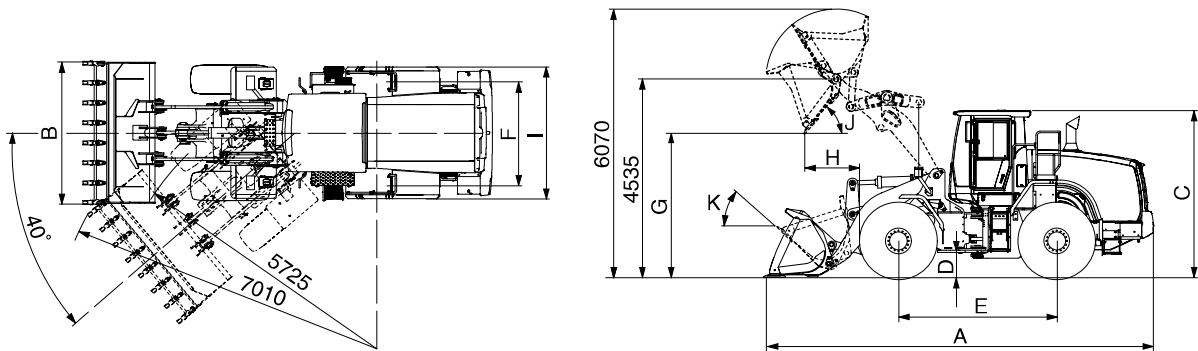

960A2SE02-1

Description		Unit	Specification
Operating weight (HL960 XT / HL960 HD XT)		kg (lb)	19955 (43990) / 20205 (44540)
Bucket capacity	Struck	m ³ (yd ³)	2.8 (3.6)
	Heaped		3.2 (4.2)
Overall length	A	mm (ft-in)	8845 (29' 0")
Overall width	B		2950 (9' 8")
Overall height	C		3450 (11' 4")
Ground clearance	D		410 (1' 4")
Wheelbase	E		3300 (10' 10")
Tread	F		2160 (7' 1")
Dump clearance at 45°	G		3240 (10' 8")
Dump reach (full lift)	H		1465 (4' 9")
Width over tires	I		2770 (9' 1")
Dump angle	J		degree (°)
Roll back angle (carry position)	K	48	
Cycle time	Lift (with load)	sec	5.8
	Dump (with load)		2.0
	Lower (empty)		3.6
Maximum travel speed		km/hr (mph)	39.0 (24.2)
Braking distance		m (ft-in)	13.3 (43' 8")
Minimum turning radius (center of outside tire)			5.72 (18' 9")
Gradeability		degree (°)	30
Breakout force		kg (lb)	17465 (38500)
Travel speed	Forward	First gear	6.4 (4.0)
		Second gear	12.1 (7.5)
		Third gear	24.5 (15.2)
		Fourth gear	39.0 (24.2)
	Reverse	First gear	6.8 (4.2)
		Second gear	12.8 (7.9)
Third gear		25.7 (15.9)	

3. WEIGHT

Item		kg	lb
Front frame assembly (HL960A / HL960A XT)		1640	3615
Front frame assembly (HL960A HD / HL960A HD XT)		1645	3626
Rear frame assembly		1937	4270
Front fender (LH & RH)		64	141
Counterweight	HL960A / HL960A XT	884/1520	1948/3351
	HL960A HD / HL960A HD XT		
Cab assembly		1048	2310
Engine assembly		534	1177
Transmission assembly (4-speed/5-speed)		558/583	1230/1285
Drive shaft (front)		34	75
Drive shaft (center)		23	51
Drive shaft (rear)		12	26
Front axle (include differential) (HL960A / HL960A XT)		1050	2314
Front axle (include differential) (HL960A HD / HL960A HD XT)		1236	2724
Rear axle (include differential) (HL960A / HL960A XT)		1070	2358
Rear axle (include differential) (HL960A HD / HL960A HD XT)		1450	3197
Tire (23.5 R25, ★ ★, L3)		343	756
Hydraulic tank assembly		186	410
Fuel tank assembly		331	729
Main pump assembly		62	136
Brake pump assembly		11	24
Main control valve (2/3 spool)		90 /105	198/231
Steering valve (priority valve)		5.9	13
Boom assembly	HL960A / HL960A XT	1257/1434	2771/3161
	HL960A HD / HL960A HD XT		
Bell crank assembly		361	795
Bucket link		64	141
3.3 m ³ bucket, with bolt on cutting edge		1843	4063
3.2 m ³ bucket, with tooth		1767	3895
Boom cylinder assembly (LH&RH)		342	754
Bucket cylinder assembly (HL960A / HL960A XT)		163	359
Bucket cylinder assembly (HL960A HD / HL960A HD XT)		181	399
Steering cylinder assembly (LH & RH)		58	128
Seat		80	176
Battery		45	99

4. SPECIFICATION FOR MAJOR COMPONENTS

1) ENGINE

Item	Specification
Model	Cummins B6.7
Type	4-cycle turbocharged, charge air cooled diesel engine
Control type	Electronic control
Cooling method	Water cooling
Number of cylinders and arrangement	6 cylinders, in-line
Firing order	1-5-3-6-2-4
Combustion chamber type	Direct injection type
Cylinder bore × stroke	107 × 124 mm (4.2" × 4.9")
Piston displacement	6700 cc (408 cu in)
Compression ratio	17.3 : 1
Rated horse power (Gross)	225 hp at 2200 rpm
Maximum torque (1300 rpm)	121 kgf·m (875 lbf·ft)
Engine oil quantity	18ℓ (4.8 U.S. gal)
Wet weight	583 kg (1285 lb)
High idling speed	2230 ± 50 rpm
Low idling speed	800 ± 25 rpm
Rated fuel consumption (at rated)	206 g/kW·hr
Starting motor	Melco 90P(24V-5.5kW)
Alternator	Denso, 24V-95Amp
Battery	2 × 12V × 160Ah

2) MAIN PUMP

Item	Specification	
	Steering	Loader
Type	Variable piston pump	
Capacity	74 cc/rev	45 cc/rev
Maximum operating pressure	280 kgf/cm ² (3980 psi)	
Rated oil quantity (at 2200 rpm)	163ℓ/min (43.0 U.S.gpm)	99ℓ/min (26.2 U.S.gpm)
Maximum speed	2230 rpm	

3) FAN AND BRAKE PUMP

Item	Specification
Type	Variable piston pump
Capacity	28 cc/rev
Maximum operating pressure	250 kgf/cm ² (3560 psi)
Rated oil quantity (at 2200 rpm)	62ℓ/min (16.3 U.S.gpm)
Maximum speed	2230 rpm

4) MAIN CONTROL VALVE

Item	Specification
Type	2 spool / 3 spool
Operating method	Hydraulic pilot assist
System pressure	280 kgf/cm ² (3980 psi)
Overload relief valve pressure	340 kgf/cm ² (4840 psi)

5) ELECTRO-HYDRAULIC (INCLUDED IN MCV SIDE)

Item	Specification
Type	Proportional pressure reducing valve
Control current	0~800 mA
Resistance	12 Ω
Normal flow	7.5 lpm (1.98 U.S.gpm)

6) REMOTE CONTROL VALVE (EH TYPE)

Item	Specification
Type	Fingertip
Axle	Single axle for boom, bucket, auxiliary
Operating voltage	4.5~5.5 V
Output signal	0.5~4.5 V (neutral 2.5 V)

7) REMOTE CONTROL VALVE (FNR TYPE)

Item	Specification
Type	Joystick
Axle	Two axle for boom, bucket, roller for auxiliary
Operating type	CAN J1939
Baud rate	500 Kbps

8) CYLINDER

Item	Specification
Boom cylinder	Bore dia×Rod dia×Stroke ∅140×∅80×765 mm
Bucket cylinder	Bore dia×Rod dia×Stroke ∅160×∅85×530 mm
Steering cylinder	Bore dia×Rod dia×Stroke ∅ 80×∅45×424 mm

9) DYNAMIC POWER TRANSMISSION DEVICES

Item	Specification		
4-speed transmission (std)	Model	ZF 4WG 210	
	Type	Converter	Single-stage, single-phase
		Transmission	Full-automatic power shift
	Gear shift	Forward fourth gear, reverse third gear	
	Control	Electrical single lever type, kick-down system	
	Travel speed	Forward 1/2/3/4 : 6.4 / 12.1 / 24.5 / 39.0 km/hr Reverse 1/2/3 : 6.8/12.8/25.7 km/hr	
5-speed transmission (opt)	Model	ZF 5WG210	
	Type	Converter	Single-stage, double-phase (with lock up clutch)
		Transmission	Full-automatic power shift
	Gear shift	Forward fifth gear, reverse third gear	
	Control	Electrical single lever type, kick-down system	
	Travel speed	Forward 1/2/3/4/5	6.7/11.8/18.2/ 28.4/ 40.0 km/hr
Reverse 1/2/3		7.1/12.5/29.9 km/hr	
Axle	Drive devices	4-wheel drive	
	Front	Front fixed location	
	Rear	Oscillation ±12° of center pin-loaded	
Wheels	Tires	23.5 R25, ★★, L3)	
Brakes	Travel	Four-wheel, wet-disc type, full hydraulic	
	Parking	Spring applied, hydraulic released brake on transmission	
Steering	Type	Full hydraulic, articulated	
	Steering angle	40° to both right and left angle, respectively	
	Relief pressure	210 kgf/cm ² (2990 psi)	

5. TIGHTENING TORQUE

Use following table for unspecified torque.

1) BOLT AND NUT

(1) Coarse thread

Bolt size	8.8T		10.9T		12.9T	
	kgf · m	lbf · ft	kgf · m	lbf · ft	kgf · m	lbf · ft
M 6×1.0	0.8 ~ 1.2	5.8 ~ 8.6	1.2 ~ 1.8	8.7 ~ 13.0	1.5 ~ 2.1	10.9 ~ 15.1
M 8×1.25	2.0 ~ 3.0	14.5 ~ 21.6	2.8 ~ 4.2	20.3 ~ 30.4	3.4 ~ 5.0	24.6 ~ 36.1
M10×1.5	4.0 ~ 6.0	29.0 ~ 43.3	5.6 ~ 8.4	40.5 ~ 60.8	6.8 ~ 10.0	49.2 ~ 72.3
M12×1.75	6.8 ~ 10.2	50.0 ~ 73.7	9.6 ~ 14.4	69.5 ~ 104	12.3 ~ 16.5	89.0 ~ 119
M14×2.0	10.9 ~ 16.3	78.9 ~ 117	16.3 ~ 21.9	118 ~ 158	19.5 ~ 26.3	141 ~ 190
M16×2.0	17.9 ~ 24.1	130 ~ 174	25.1 ~ 33.9	182 ~ 245	30.2 ~ 40.8	141 ~ 295
M18×2.5	24.8 ~ 33.4	180 ~ 241	34.8 ~ 47.0	252 ~ 340	41.8 ~ 56.4	302 ~ 407
M20×2.5	34.9 ~ 47.1	253 ~ 340	49.1 ~ 66.3	355 ~ 479	58.9 ~ 79.5	426 ~ 575
M22×2.5	46.8 ~ 63.2	339 ~ 457	65.8 ~ 88.8	476 ~ 642	78.9 ~ 106	570 ~ 766
M24×3.0	60.2 ~ 81.4	436 ~ 588	84.6 ~ 114	612 ~ 824	102 ~ 137	738 ~ 991
M30×3.5	120 ~ 161	868 ~ 1164	168 ~ 227	1216 ~ 1641	202 ~ 272	1461 ~ 1967

(2) Fine thread

Bolt size	8.8T		10.9T		12.9T	
	kgf · m	lbf · ft	kgf · m	lbf · ft	kgf · m	lbf · ft
M 8×1.0	2.1 ~ 3.1	15.2 ~ 22.4	3.0 ~ 4.4	21.7 ~ 31.8	3.6 ~ 5.4	26.1 ~ 39.0
M10×1.25	4.2 ~ 6.2	30.4 ~ 44.9	5.9 ~ 8.7	42.7 ~ 62.9	7.0 ~ 10.4	50.1 ~ 75.2
M12×1.25	7.3 ~ 10.9	52.8 ~ 78.8	10.3 ~ 15.3	74.5 ~ 110	13.1 ~ 17.7	94.8 ~ 128
M14×1.5	12.4 ~ 16.6	89.7 ~ 120	17.4 ~ 23.4	126 ~ 169	20.8 ~ 28.0	151 ~ 202
M16×1.5	18.7 ~ 25.3	136 ~ 182	26.3 ~ 35.5	191 ~ 256	31.6 ~ 42.6	229 ~ 308
M18×1.5	27.1 ~ 36.5	196 ~ 264	38.0 ~ 51.4	275 ~ 371	45.7 ~ 61.7	331 ~ 446
M20×1.5	37.7 ~ 50.9	273 ~ 368	53.1 ~ 71.7	384 ~ 518	63.6 ~ 86.0	460 ~ 622
M22×1.5	51.2 ~ 69.2	370 ~ 500	72.0 ~ 97.2	521 ~ 703	86.4 ~ 116	625 ~ 839
M24×2.0	64.1 ~ 86.5	464 ~ 625	90.1 ~ 121	652 ~ 875	108 ~ 146	782 ~ 1056
M30×2.0	129 ~ 174	933 ~ 1258	181 ~ 245	1310 ~ 1772	217 ~ 294	1570 ~ 2126

2) PIPE AND HOSE (FLARE type)

Thread size	Width across flat (mm)	kgf·m	lbf·ft
1/4"	19	4	28.9
3/8"	22	5	36.2
1/2"	27	9.5	68.7
3/4"	36	18	130
1"	41	21	152
1-1/4"	50	35	253

3) PIPE AND HOSE (ORFS type)

Thread size	Width across flat (mm)	kgf·m	lbf·ft
9/16-18	19	4	28.9
11/16-16	22	5	36.2
13/16-16	27	9.5	68.7
1-3/16-12	36	18	130
1-7/16-12	41	21	152
1-11/16-12	50	35	253

4) FITTING

Thread size	Width across flat (mm)	kgf·m	lbf·ft
1/4"	19	4	28.9
3/8"	22	5	36.2
1/2"	27	9.5	68.7
3/4"	36	18	130
1"	41	21	152
1-1/4"	50	35	253

5) TIGHTENING TORQUE OF MAJOR COMPONENT

No.	Descriptions	Bolt size	Torque		
			kgfm	lbf-ft	
1	Engine	Engine mounting bolt, nut (rubber, 2EA)	M20×2.5	57.9 ± 8.7	419 ± 63
2		Engine mounting bolt (bracket, 8EA)	M12×1.75	11.7 ± 1.8	84.6 ± 13.0
3		Engine mounting bolt (T/C housing, 3EA)	M10×1.5	4.6 ± 0.9	33.3 ± 6.5
4		Engine mounting bolt (flywheel, 8EA)	M10×1.5	4.5 ± 0.6	32.5 ± 4.3
5		Fan motor mounting bolt	M12×1.75	12.8 ± 3.0	92.6 ± 21.7
6		Radiator mounting bolt	M16×2.0	29.7 ± 5.9	215 ± 42.7
7		Fuel tank mounting bolt, nut	M16×2.0	29.7 ± 4.5	215 ± 32.5
8	Hydraulic system	Main pump housing mounting bolt	M16×2.0	29.7 ± 4.5	215 ± 32.5
9		Fan & brake pump housing mounting bolt	M10×1.5	6.9 ± 1.4	50 ± 10.1
10		Main control valve mounting bolt	M12×1.75	12.8 ± 3.0	92.6 ± 21.7
11		Steering unit mounting bolt	M10×1.5	6.9 ± 1.4	50 ± 10.1
12		Steering valve (EHPS) mounting bolt	M8×1.25	2.5 ± 0.5	18.1 ± 3.6
13		Brake valve mounting bolt	M8×1.25	2.5 ± 0.5	18.1 ± 3.6
14		Cut-off valve mounting bolt	M8×1.25	2.5 ± 0.5	18.1 ± 3.6
15		EH control block mounting bolt	M8×1.25	2.5 ± 0.5	18.1 ± 3.6
16		Safety valve	M10×1.5	6.9 ± 1.4	50 ± 10.1
17		Hydraulic oil tank mounting bolt	M16×2.0	29.7 ± 4.5	215 ± 32.5
18	Power train system	Transmission mounting bolt, nut (rubber, 2EA)	M24×3.0	100 ± 15	723 ± 108
19		Transmission mounting bolt (bracket, 6EA)	M20×2.5	46.3 ± 7.0	335 ± 50.6
20		Front axle mounting bolt, nut	M33×2.0	225 ± 20	1627 ± 145
21		Rear axle support mounting bolt, nut	M36×3.0	308 ± 46.2	2227 ± 334
22		Tire mounting nut	M22×1.5	79 ± 2.5	571 ± 18.1
23		Drive shaft joint mounting bolt	1/2-20UNF	15 ± 2.0	108 ± 14.5
24	Others	Counterweight mounting bolt	M30×3.5	199 ± 30	1439 ± 216
25		Operator's seat mounting bolt	M8×1.25	3.4 ± 0.8	24.6 ± 5
26		ROPS Cab mounting bolt (4EA)	M30×3.5	199 ± 29.9	1440 ± 216
		ROPS Cab mounting nut (4EA)	M16×2.0	20.5 ± 4.7	148 ± 34

6. SPECIFICATION OF FUEL, COOLANT AND LUBRICANTS

1) NEW MACHINE

New machine used and filled with following lubricants.

Description	Specification
Engine oil (API CK-4)	SAE 15W-40, ^{★2} SAE 5W-40
DEF/AdBlue®	ISO 22241 (32.5% high-purity urea and 67.5 deionized water)
Hydraulic oil	HD Hyundai Construction Equipment genuine long life (ISO VG 46, VG 68 only) Conventional (ISO VG15 ^{★2}) HD Hyundai Construction Equipment Bio Hydraulic Oil (HBHO, ISO VG 46)
Transmission oil	SAE 15W-40
Axle oil	[★] Refer to below list
Grease	Lithium base grease NLGI No. 2
Fuel	ASTM D975-No. 2, ^{★1} Ultra low sulfur diesel
Coolant	ASTM D6210 Mixture of 50% ethylene glycol base antifreeze and 50% water Mixture of 60% ethylene glycol base antifreeze and 40% water ^{★2}

SAE : Society of Automotive Engineers	[★] Recommended oil list
API : American Petroleum Institute	- BP TERRAC SUPER TRANSMISSION 10W-30
ISO : International Organization for Standardization	- CASTROL AGRI TRANS PLUS 10W-30
NLGI : National Lubricating Grease Institute	- MOBILFLUID 426
ASTM : American Society of Testing and Material	- SHELL DONAX TD 10W-30
DEF : Diesel Exhaust Fluid DEF compatible with AdBlue®	- TOTAL DYNATRANS MPV
	^{★1} Ultra low sulfur diesel - sulfur content ≤ 15 ppm
	^{★2} Cold region Russia, CIS, Mongolia

2) RECOMMENDED OILS

HD Hyundai Construction Equipment genuine lubricating oils have been developed to offer the best performance and service life for your equipment. These oils have been tested according to the specifications of HD Hyundai Construction Equipment and, therefore, will meet the highest safety and quality requirements.

We recommend that you use only HD Hyundai Construction Equipment genuine lubricating oils and grease officially approved by HD Hyundai Construction Equipment.

- ※ Using any lubricating oils other than HD Hyundai Construction Equipment genuine products may lead to a deterioration of performance and cause damage to major components.
- ※ Do not mix HD Hyundai Construction Equipment genuine oil with any other lubricating oil as it may result in damage to the systems of major components.
- ※ Do not use any engine oil other than that specified above, as it may clog the diesel particulate filter(DPF).
- ※ For HD Hyundai Construction Equipment genuine lubricating oils and grease for use in regions with extremely low temperatures, please contact HD Hyundai Construction Equipment dealers.

Service point	Kind of fluid	Capacity ℓ (U.S. gal)	Ambient temperature °C(°F)							
			-50 (-58)	-30 (-22)	-20 (-4)	-10 (14)	0 (32)	10 (50)	20 (68)	30 (86)
Engine oil pan	Engine oil	18 (4.8)	SAE 15W-40							
			*2 SAE 5W-40							
			SAE 0W-40							
DEF/ AdBlue® tank	Mixture of urea and deionized water	37.1 (9.8)	ISO 22241, High-purity urea + deionized water (32.5 : 67.5)							
Transmission	Engine oil	33 (8.7)	SAE 10W-30							
			SAE 15W-40							
Axle *4	UTTO	FR : 35 (9.2) RR : 35 (9.2) FR : 42 (11.1)*6 RR : 40 (10.6)*6	* Refer to below list							
			*2 ISO VG 15							
Hydraulic tank	Hydraulic oil	Tank: 110 (29.1) System: 200 (52.8)	ISO VG 46, HBHO VG 46*5							
			ISO VG 68							
			*2 ASTM D975 NO.1							
Fuel tank	Diesel fuel*1	260 (68.6)	ASTM D975 NO.2							
			*2 NLGI NO.1							
Fitting (grease nipple)	Grease	As required	NLGI NO.2							
			Ethylene glycol base permanent type (50 : 50)							
Radiator (reservoir tank)	Mixture of antifreeze and soft water*3	42 (11.1)	*2 Ethylene glycol base permanent type (60 : 40)							

SAE : Society of Automotive Engineers

API : American Petroleum Institute

ISO : International Organization for Standardization

NLGI : National Lubricating Grease Institute

ASTM : American Society of Testing and Material

UTTO : Universal Tractor Transmission Oil

DEF : Diesel Exhaust Fluid

DEF compatible with AdBlue®

*1 Ultra low sulfur diesel
- sulfur content ≤ 15 ppm

* Recommended oil list

- BP TERRAC SUPER TRANSMISSION 10W-30

- CASTROL AGRI TRANS PLUS 10W-30

- MOBILFLUID 426

- SHELL DONAX TD 10W-30

- TOTAL DYNATRANS MPV

*2 Cold region : Russia, CIS, Mongolia

*3 Soft water : City water or distilled water

*4 If the machine is equipped with axle oil cooler,
refer to page 6-44 in operator's manual.

*5 HD Hyundai Construction Equipment Bio Hydraulic Oil

*6 HL960A HD

GROUP 3 OPERATIONAL CHECKOUT RECORD SHEET

- Owner : _____
- Date : _____
- Hours : _____
- Serial No. : _____
- Technician : _____

※ **Use this sheet to record operational checkout results.**
Perform the operational check before installing any test equipment.

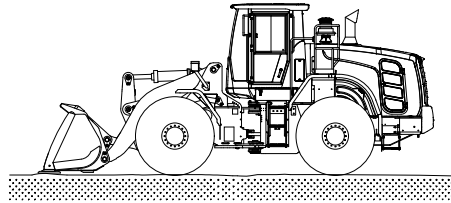

760F1GE02

Item	OK	NOT OK	Comments
------	----	-----------	----------

1. Monitor indicator and gauge checks (engine OFF)

- Hourmeter and gauge check _____
- Battery check _____
- Monitor indicator circuit check _____
- Cluster turn signals and warning indicator check _____

2. Transmission, axle and engine, neutral start switch and reverse warning alarm switch checks

- Transmission control lever and neutral _____
- Neutral start and reverse warning _____
- Alarm circuit checks _____

3. Monitor indicator and gauge checks (engine running)

- Monitor display and alternator output checks _____
- Monitor bypass circuit and seat belt indicator check _____
- Monitor primary and secondary level check _____
- Transmission oil warm up procedure _____
- Transmission temperature gauge check _____

4. Brake system and clutch cut off checks

- Park brake capacity check _____
- Park brake transmission lockout check _____
- Service brake pump flow check _____
- Service brake capacity check _____
- Brake accumulator precharge check _____
- Brake system leakage check _____
- Service brake pedal check _____
- Service and park brake system drag check _____
- Clutch cut off check _____

5. Driving checks

- Transmission oil warm up procedure _____
- Transmission noise check _____
- Speedometer check _____
- Transmission kick down system check _____
- 1st, 2nd, 3rd and 4th speed clutch pack drag check _____
- Transmission pressure, pump flow and leakage check _____
- Transmission shift modulation check _____
- Torque converter check _____
- Engine power check _____

6. Hydraulic system checks

- Hydraulic system warm up procedure _____
- Hydraulic pump performance check _____
- Pilot control valve boom float check _____
- Boom down solenoid valve check _____
- Control valve lift check _____
- Bucket rollback circuit relief valve check _____
- Bucket dump circuit relief
- Low pressure check _____
- High pressure check _____
- Boom and bucket cylinder drift check _____
- Boom down solenoid valve leakage check _____
- Pilot controller check _____
- Return to dig check _____
- Boom height kickout check-if equipped _____

7. Steering system checks

- Steering unit check _____
- Steering system leakage check _____
- Steering valve (EHPS)
Low check pressure _____
- High check pressure _____

8. Accessory checks

- Operating lights check _____
- Work light check _____
- Brake light check _____
- Cab light check _____
- Horn circuit check _____
- Windshield washer and wiper check _____
- Defroster blower check _____
- Heater/Air conditioner blower check _____
- Heater functional check _____
- Air conditioner functional check _____
- Start aid system check _____

9. Cab components and vandal protection checks

- Cab door latch check _____
- Cab door hold open latch check _____
- Cab door release button check _____
- Cab door lock check _____
- Cab door window check _____
- Cab window latch check _____
- Steering column adjustment check _____
- Seat and seat belt check _____
- Air intake filter door check _____
- Engine side panels check _____
- Radiator cap access door check _____
- Frame locking bar check _____
- Boom lock check _____
- Service decal check _____