

SECTION 4 BRAKE AND FAN SYSTEM

Group 1	Structure and Function	4-1
Group 2	Operational Checks and Troubleshooting	4-32
Group 3	Tests and Adjustments	4-39
Group 4	Disassembly and Assembly	4-41

SECTION 4 BRAKE AND FAN SYSTEM

GROUP 1 STRUCTURE AND FUNCTION

1. OUTLINE

The variable displacement piston pump supplies the hydraulic oil that is required in order to operate the brake and the hydraulic fan system. Oil flows from pump to the cut-off valve.

The cut-off valve controls the flow of oil from the pump to the brake accumulators and also controls the flow of oil to the hydraulic fan motor.

The cut-off valve contains a priority valve. The brake system has priority. The oil flows to the brake accumulators while the accumulators are charged. After the accumulators are fully charged, the oil then flows to the hydraulic fan system.

The accumulator has pre-charged gas and an inlet check valve to maintain a pressurized volume of oil for reserving brake system.

The oil through the accumulator flows to the brake valves. The brake valve is a closed center design, dual circuit operated by a pedal.

The front and rear brakes will operate simultaneously with only one brake pedal depressed.

The hydraulic fan system is used to meet the cooling requirements. The hydraulic fan system controls the fan speed through the pump output pressure. The desired pressure level can be set by varying the solenoid current.

The hydraulic fan system contains directional valve that reverses the direction of fan.

The brake and hydraulic fan system contains the following components :

- Fan & brake pump
- Cut-off valve
- Brake valve
- Accumulators
- Pressure sensors and switch
- Fan motor
- Directional valve

FULL POWER HYDRAULIC BRAKE SYSTEM

ADVANTAGES - The full power hydraulic brake system has several advantages over traditional brake actuation systems. These systems are capable of supplying fluid to a range of very small and large volume service brakes with actuation that is faster than air brake systems. Figure represents a time comparison between a typical air/hydraulic and full power hydraulic brake actuation system.

Full power systems can supply significantly higher brake pressures with relatively low reactive pedal forces. The reactive pedal force felt by the operator will be proportional to the brake line pressure being generated.

This is referred to as brake pressure modulation.

Another key design feature of full power systems is the ability to control maximum brake line pressure. In addition, because these systems operate with hydraulic oil, filtration can be utilized to provide long component life and low maintenance operation.

Because these systems are closed center, by using a properly sized accumulator, emergency power-off braking that is identical to power-on braking can be achieved. These systems can be either dedicated, where the brake system pump supplies only the demands of the brake system or non-dedicated, where the pump supplies the demands of the brake system as well as some secondary down stream hydraulic device.

Another important note is that all seals within these system must be compatible with the fluid medium being used.

**Response time
Full power brake actuation VS
Air/Hydraulic brake actuation**

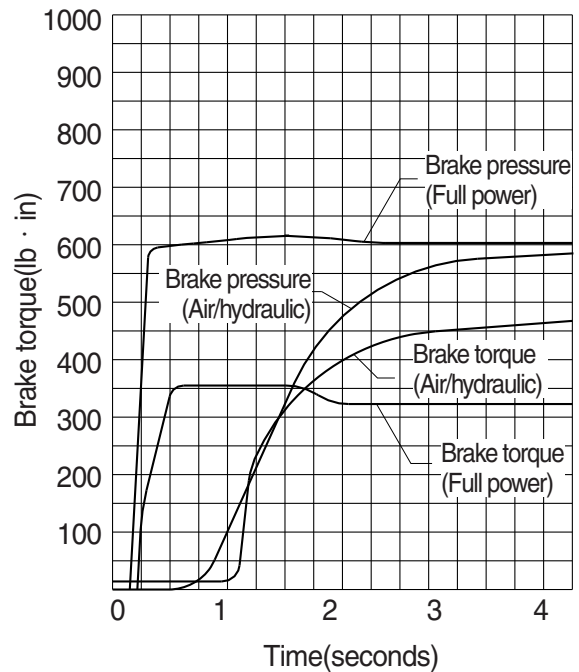

2. HYDRAULIC CIRCUIT

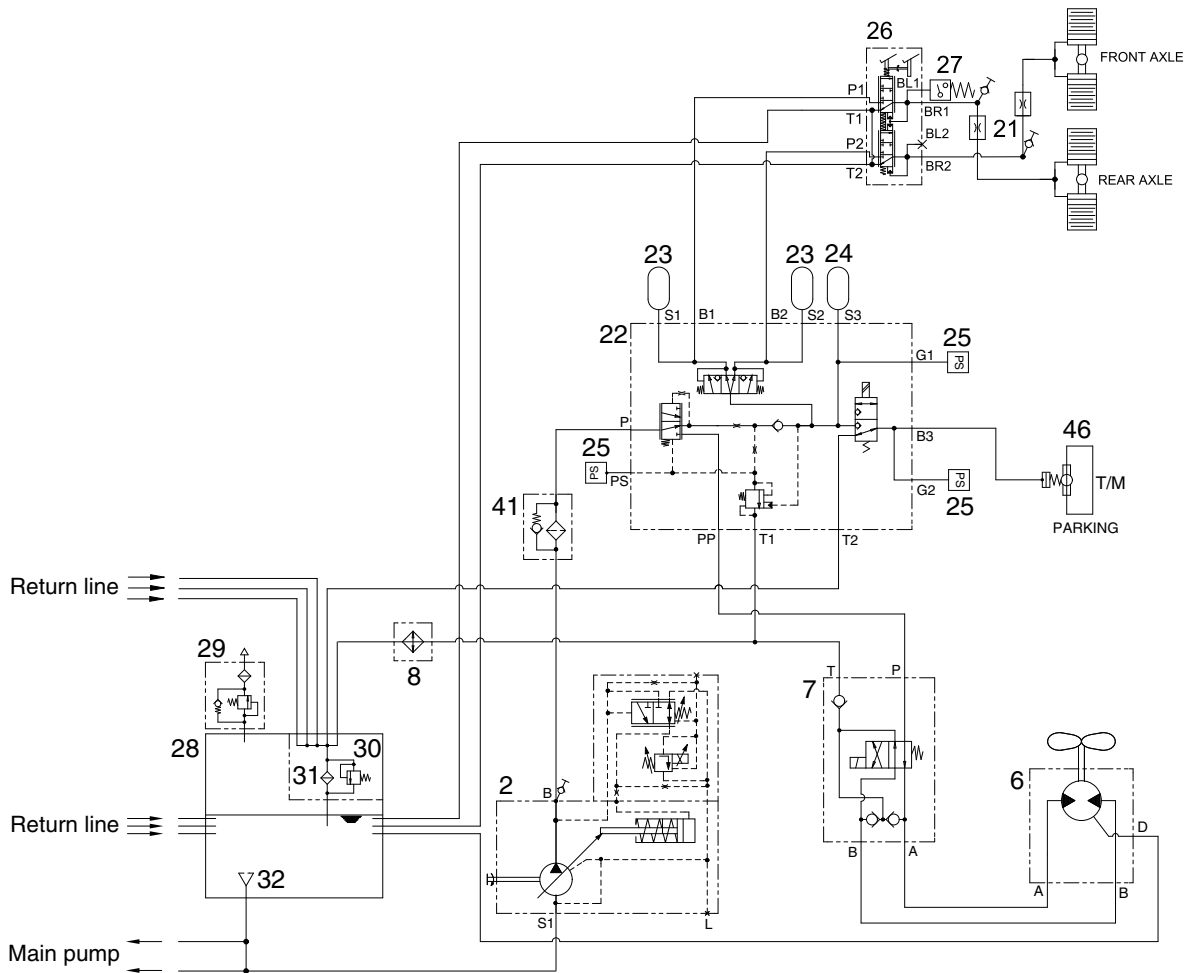

960T34BS01

- | | | | | | |
|----|-------------------|----|-----------------|----|----------------------|
| 2 | Fan & brake pump | 24 | Accumulator | 31 | Bypass valve |
| 6 | Fan motor | 25 | Pressure sensor | 32 | Strainer |
| 7 | Directional valve | 26 | Brake valve | 41 | Filter |
| 8 | Oil cooler | 27 | Pressure switch | 46 | Parking brake at T/M |
| 21 | Orifice | 28 | Hydraulic tank | | |
| 22 | Cut-off valve | 29 | Air breather | | |
| 23 | Accumulator | 30 | Return filter | | |

1) SERVICE BRAKE RELEASED

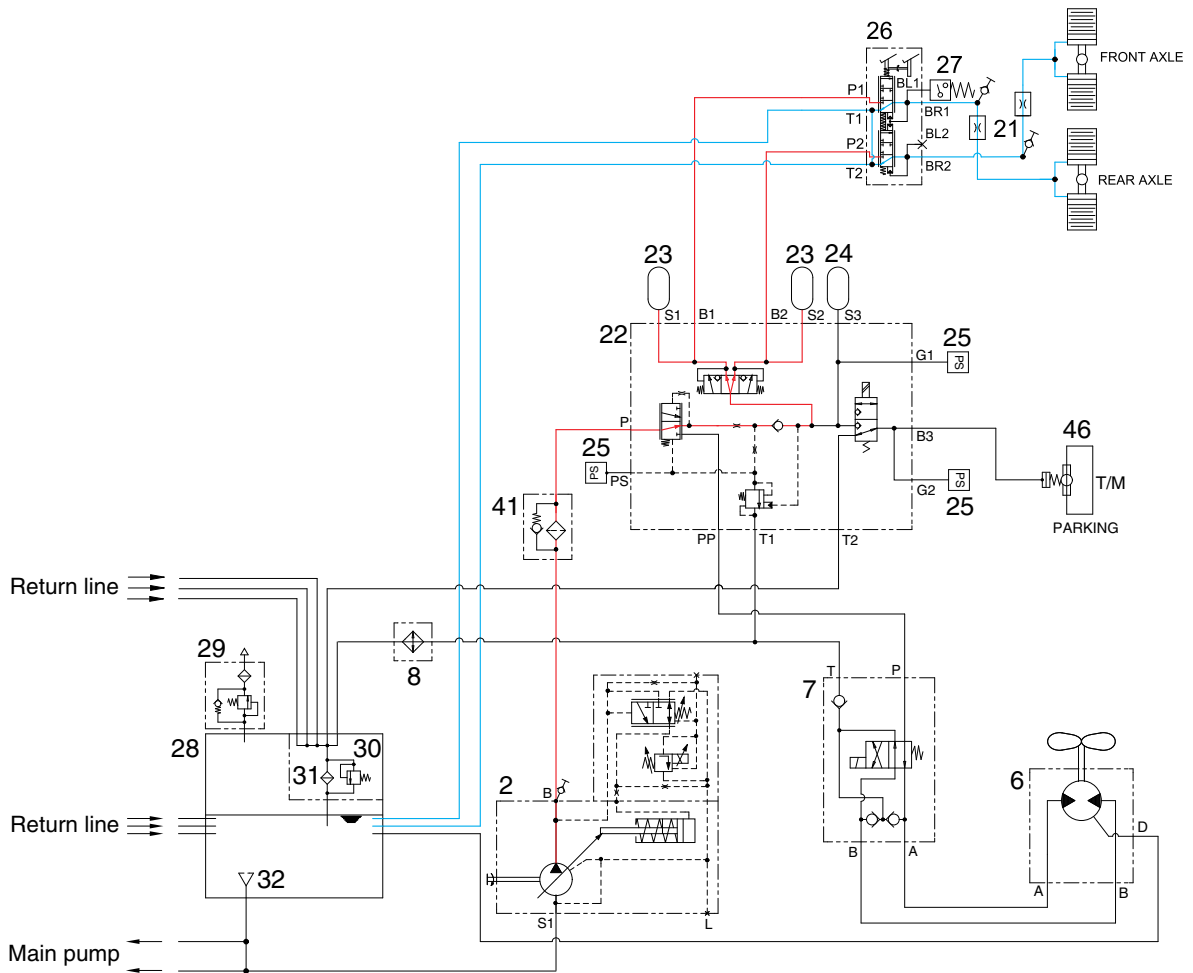

960T34BS02

When the pedal of brake valve (26) is released, the operating force is eliminated by the force of the spring, and the spool is returned.

When the spool moves up, the drain port is opened and the hydraulic oil in the piston of axles returns to the tank (28).

Therefore, the service brake is kept released.

2) SERVICE BRAKE OPERATED

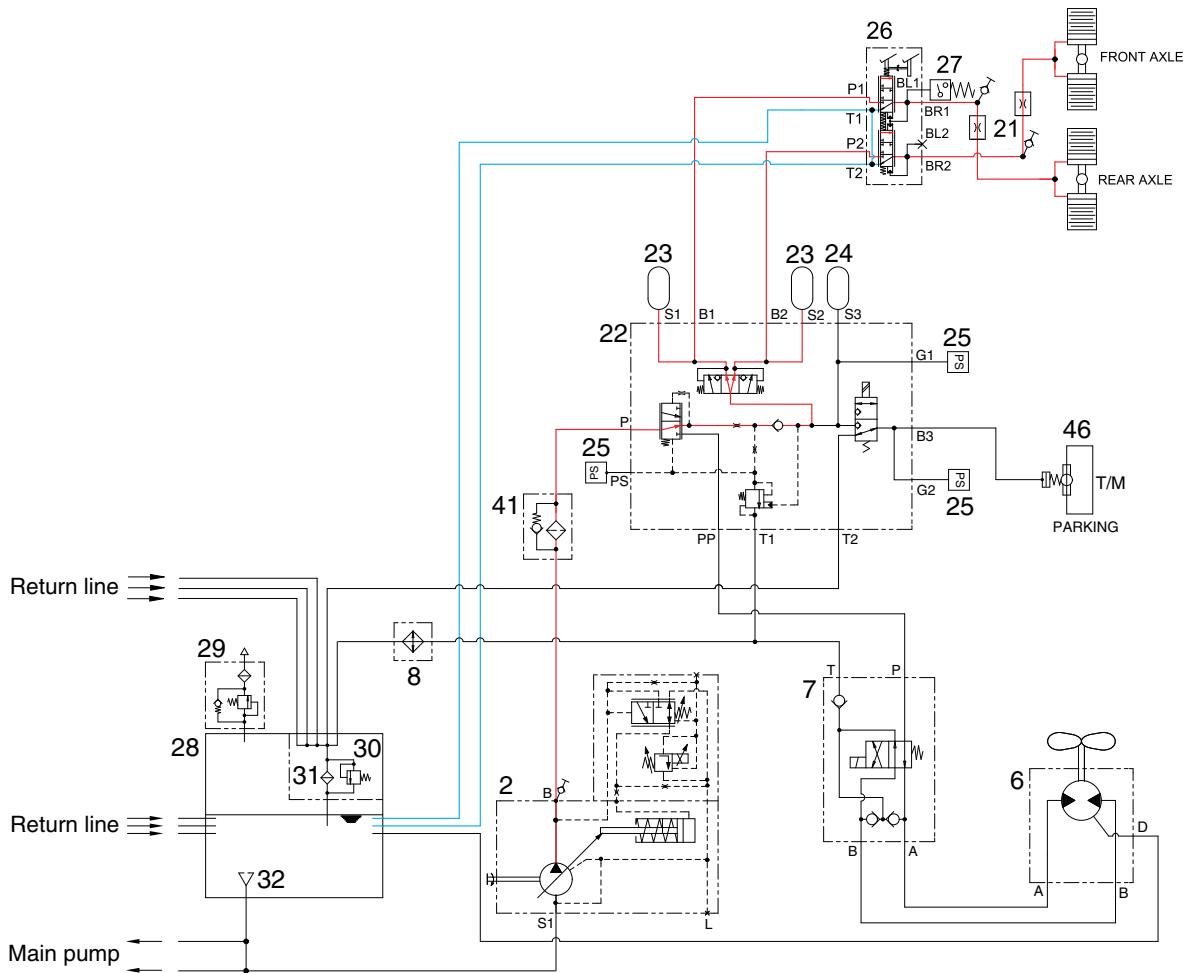

960T34BS03

When the pedal of brake valve (26) is depressed, the operating force overcomes the force of the spring, and is transmitted to the spool. When the spool moves down, the inlet port is opened, and at the same time the hydraulic oil controlled the pressure level by the cut-off valve (22) enters the piston in the front and rear axles. Therefore, the service brake is applied.

3) PARKING BRAKE RELEASED

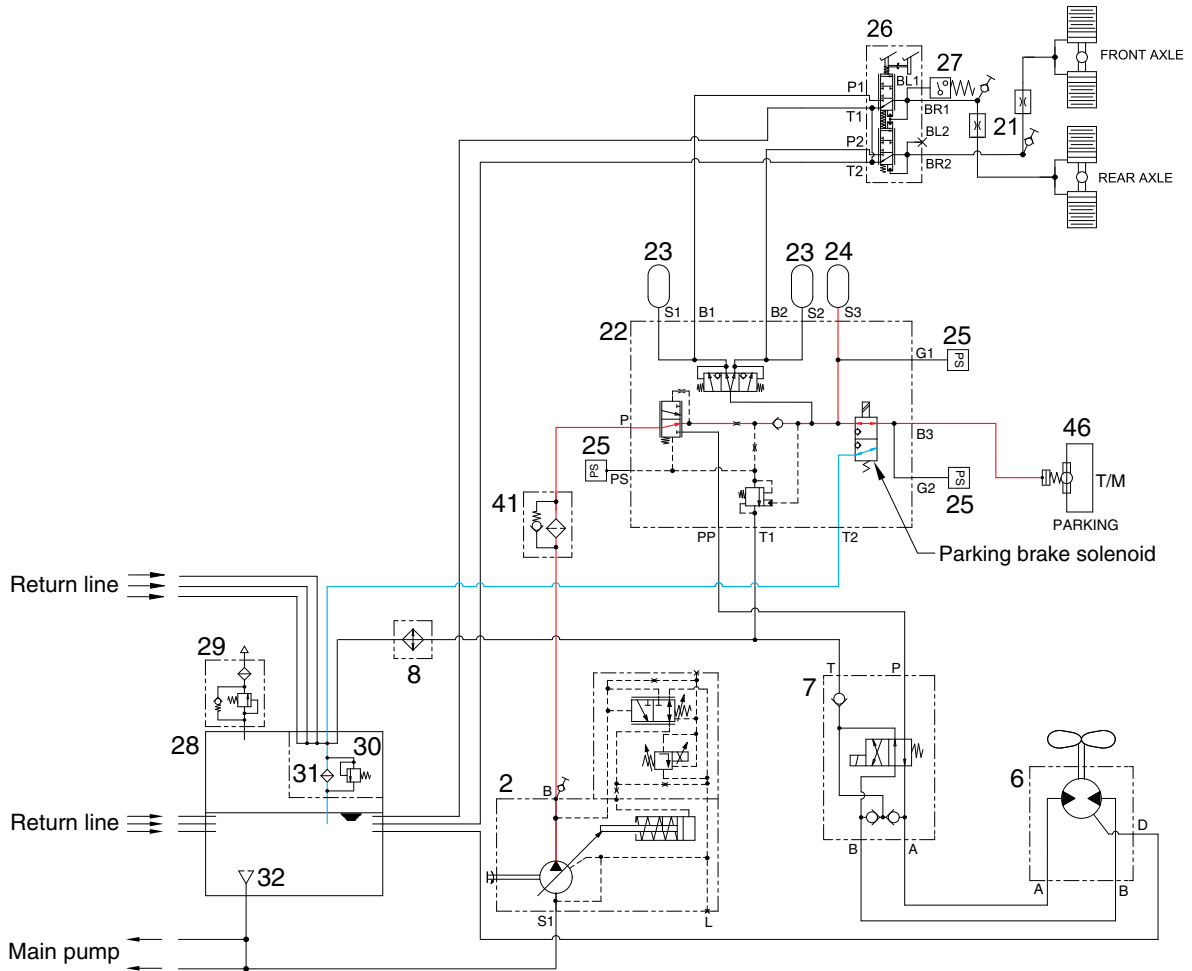

960T34BS04

When the parking brake switch is pressed A position, the solenoid valve is energized and the hydraulic oil controlled the pressure level by the cut-off valve enters the parking brake. It overcomes the force of the spring and pushes the piston rod. This releases the brake. Therefore, the hydraulic oil pressure is applied to the parking brake piston through the solenoid valve and the parking brake is kept released.

4) PARKING BRAKE OPERATED

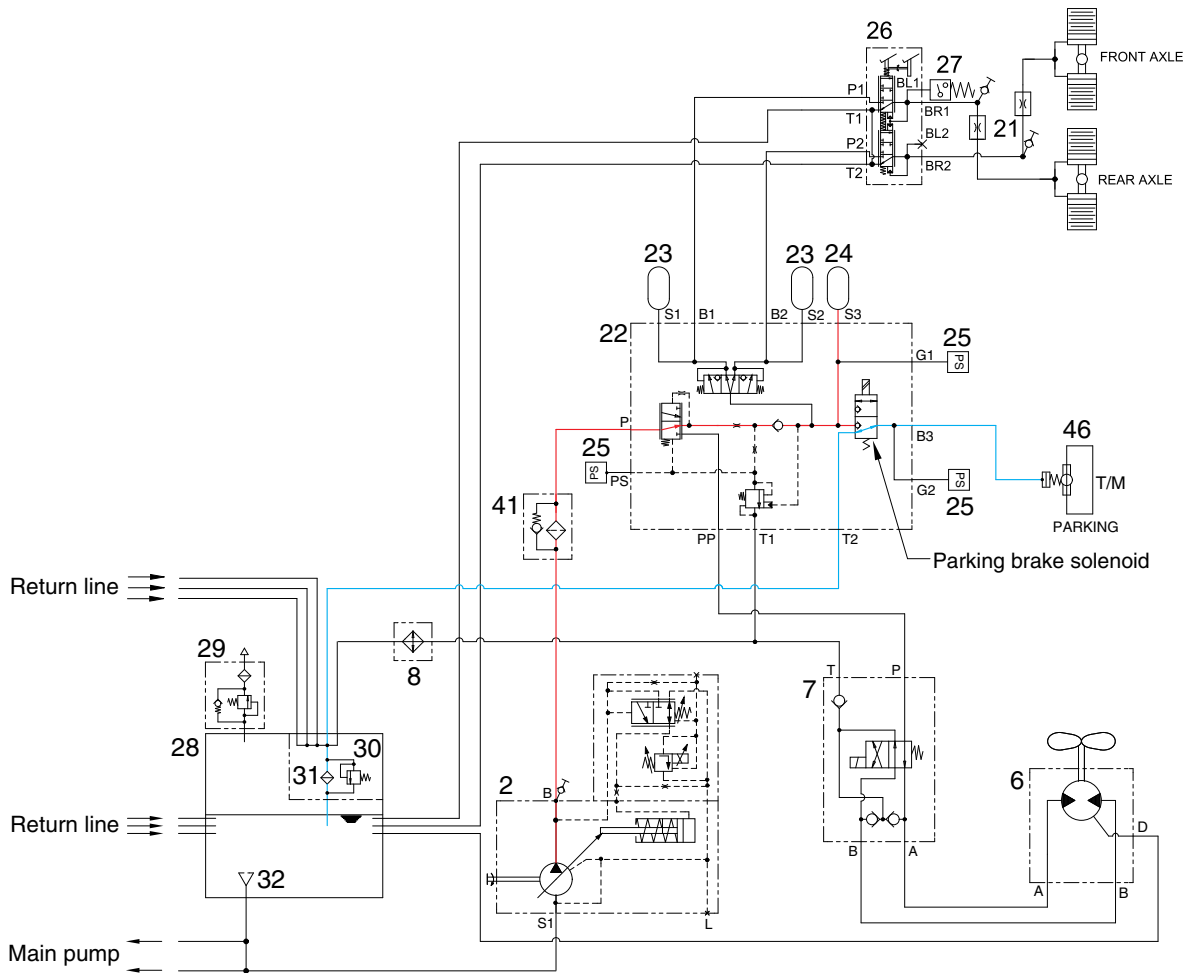

960T34BS05

When the parking brake switch is pressed B position, the solenoid valve is deenergized and the valve open the drain port.

At the same time, the hydraulic oil in the parking brake return to the tank through the solenoid valve. When the piston rod is returned by the force of the spring, the parking brake is applied.

5) FAN MOTOR OPERATED

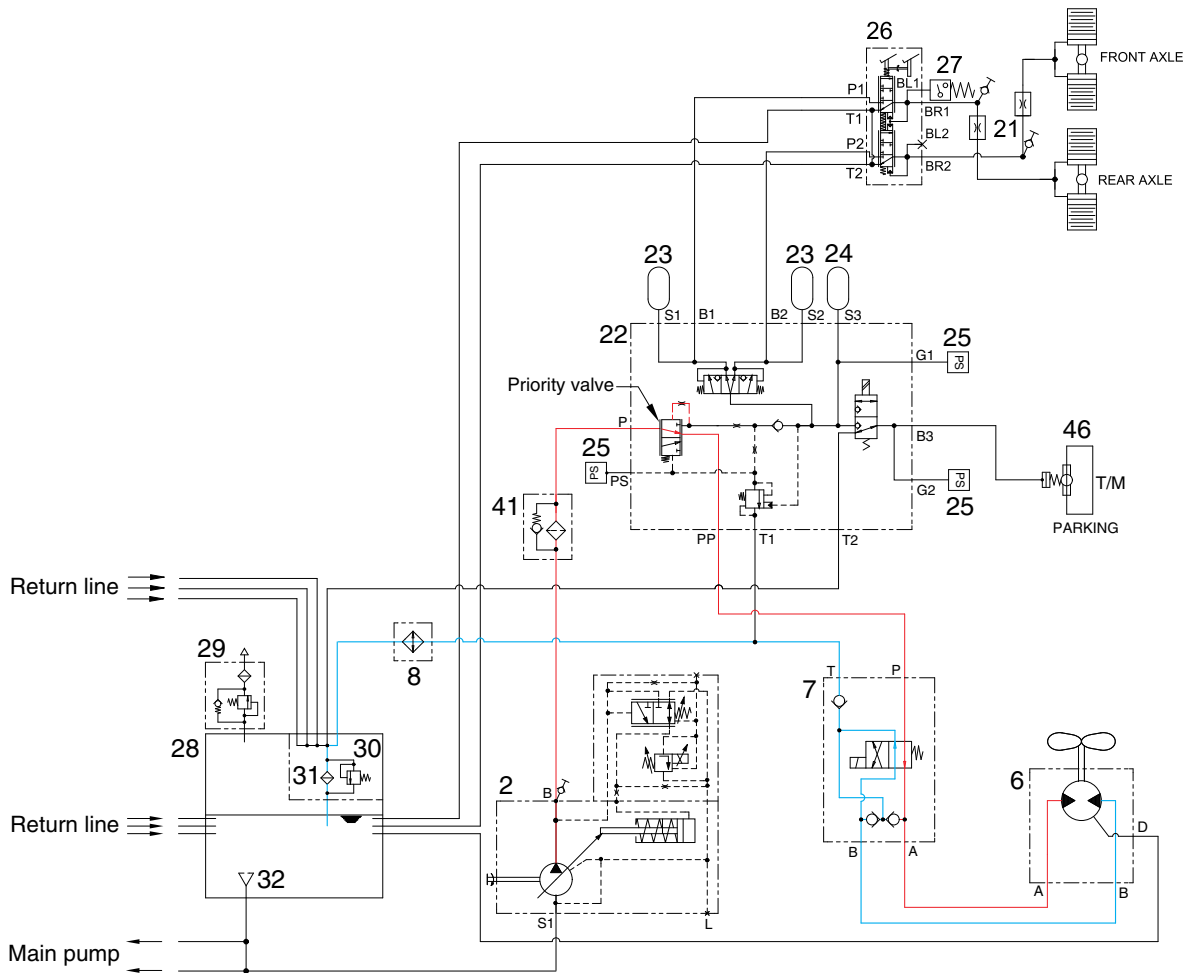

960T34BS06

When the brake accumulators are fully charged, the priority valve switches position and the oil is directed to hydraulic fan motor through directional valve (7). The flow of the oil causes fan motor (6) to rotate the fan blade. The rotation of the fan forces cool air to flow through the cooler.

6) DIRECTIONAL VALVE OPERATED

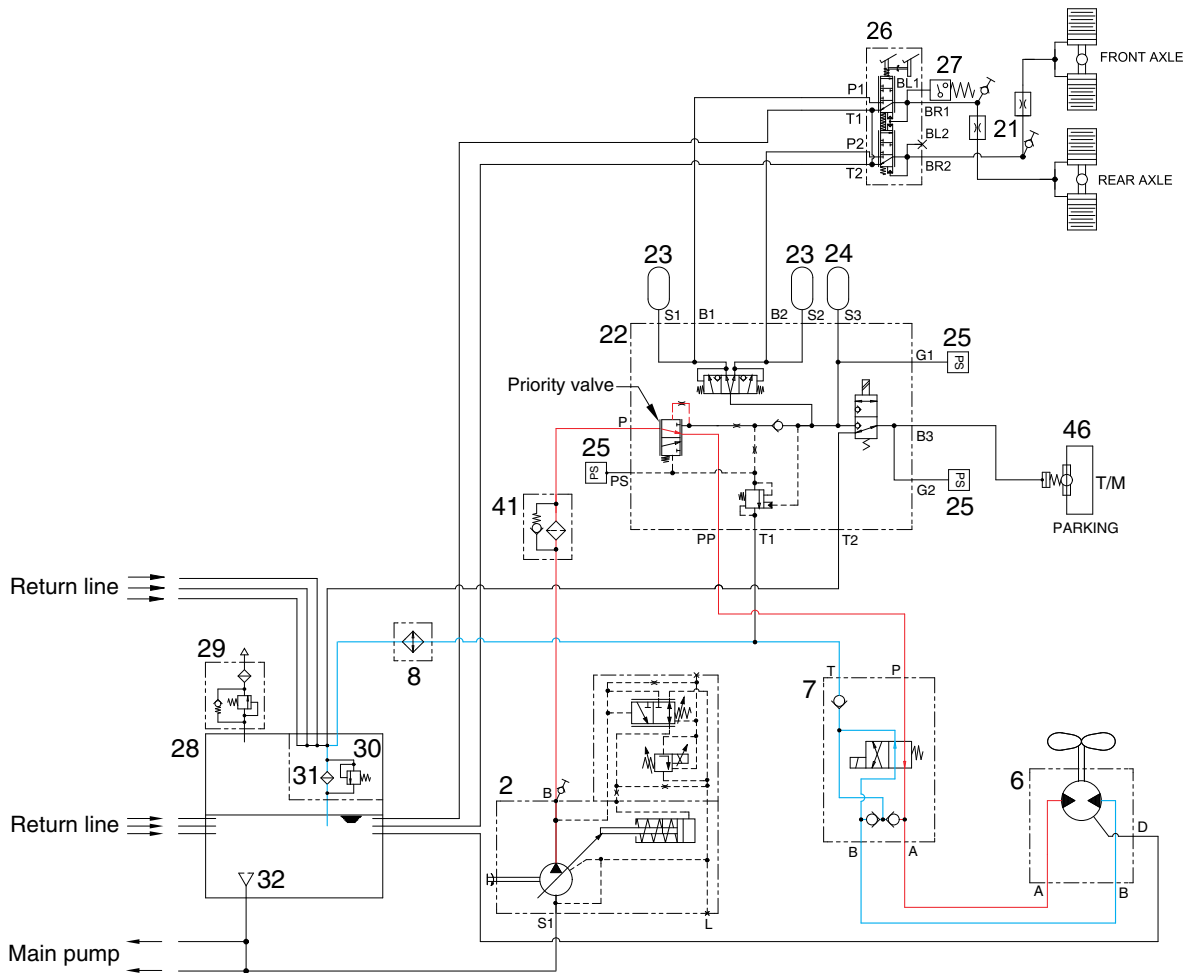

960T34BS07

When the cooling fan reverse mode is selected manual or automatic mode, the solenoid valve in the directional valve (7) is energized and the flow of the oil is changed. The rotation of the fan is reversed to clear the radiators.

3. FAN AND BRAKE PUMP

1) STRUCTURE

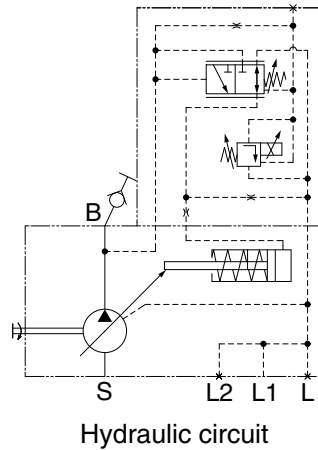
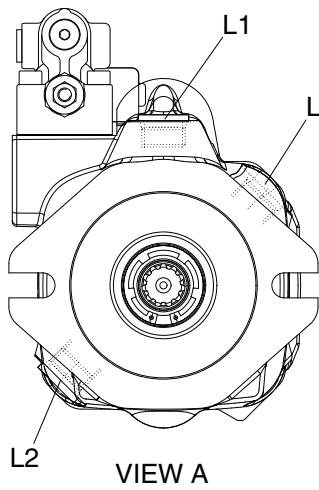
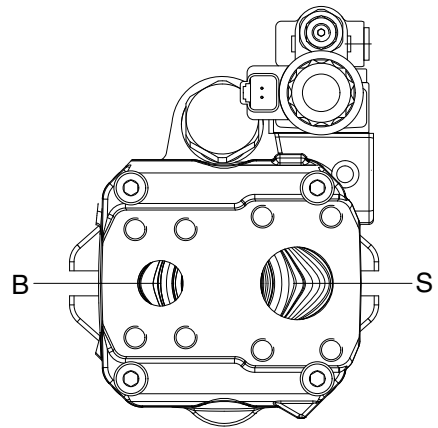
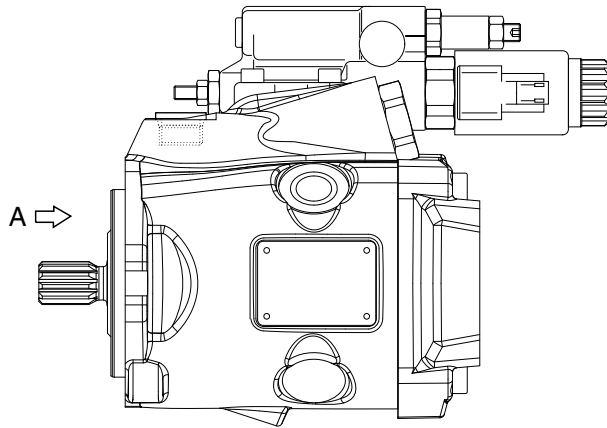

Port	Port name	Port size
B	Delivery port	SAE 3/4"
S	Suction port	SAE 1 1/4"
L, L1, L2	Drain port	3/4-16UNF-2B

7609A4BS30

2) OPERATION

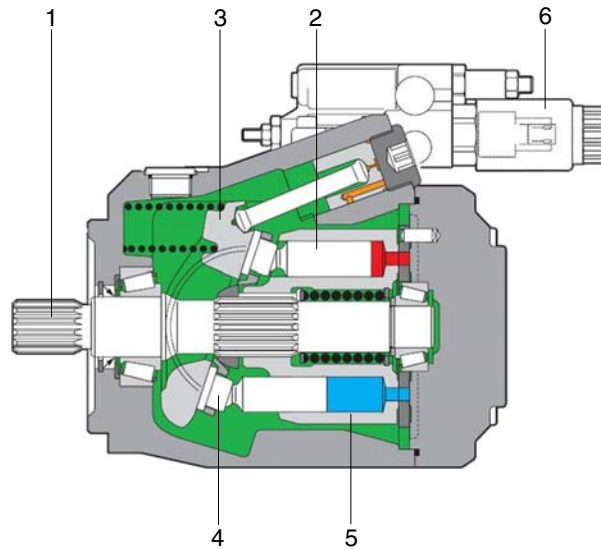

7609A4BS31

The pump is a variable displacement piston pump. This pump has a maximum delivery pressure of 250 kgf/cm². The axial piston type pump is used to supply oil flow to the cut off valve. The oil is pressurized by the movement of rotary group in the pump.

When the engine is in operation, the drive shaft (1) is driven by the gears in the engine with rotary group. There are nine piston assemblies (2) in rotary group.

Each piston inside cylinder (5) is held against swashplate (3) by piston shoe (4). Swashplate can be any angle between the maximum angle and the neutral angle. The angle of swashplate determines the amount of oil that is pushed out of each cylinder.

The neutral angle is perpendicular with drive shaft (1). When swashplate(3) is at the neutral angle, pistons (2) do not move in and out of rotating cylinder. Therefore, no oil is drawn into the pump and no oil is pushed out of the pump. The pump has zero displacement and zero flow.

When swashplate (3) is at the maximum angle, pistons (2) move in and out of cylinder. The movement of the pistons allows the maximum amount of oil to be drawn into the cylinder. The pump will produce the maximum displacement.

The swashplate (3) angle is controlled by command current signal to control valve solenoid (6). The pump output pressure level can be set by the solenoid current. When the solenoid current signal drops toward a zero value, the pump output pressure level is the maximum.

※ FAN SYSTEM OPERATION

When the brake system pressure is below minimum pressure (125 ± 5 bar), it has the high priority than the fan system. Pump flow to the fan motor is blocked while brake system is charged.

However, The fan system has controlled pump when the brake system pressure is charged.

The fan speed solenoid valve (6) controls the pressure (fan speed) of pump when the brake system is fully charged.

The fan speed solenoid valve (6) is a proportional solenoid. As current to the fan speed solenoid increases, pump output pressure decreased, therefore, the fan motor rotates slower.

When the current of the fan speed solenoid valve (6) is reduced, the output pressure is increased.

The pump will be stroked and the pump will send maximum flow to the fan motor, thus, the fan motor is turning faster.

4. BRAKE VALVE

1) STRUCTURE

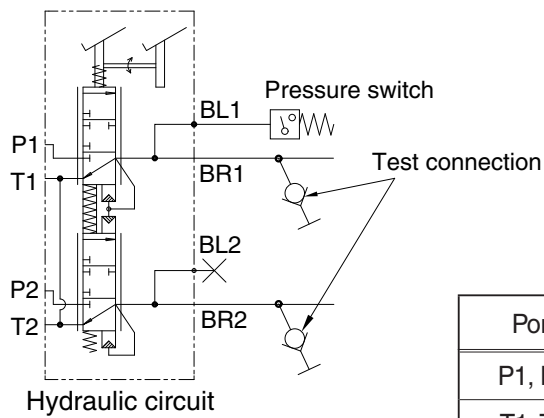
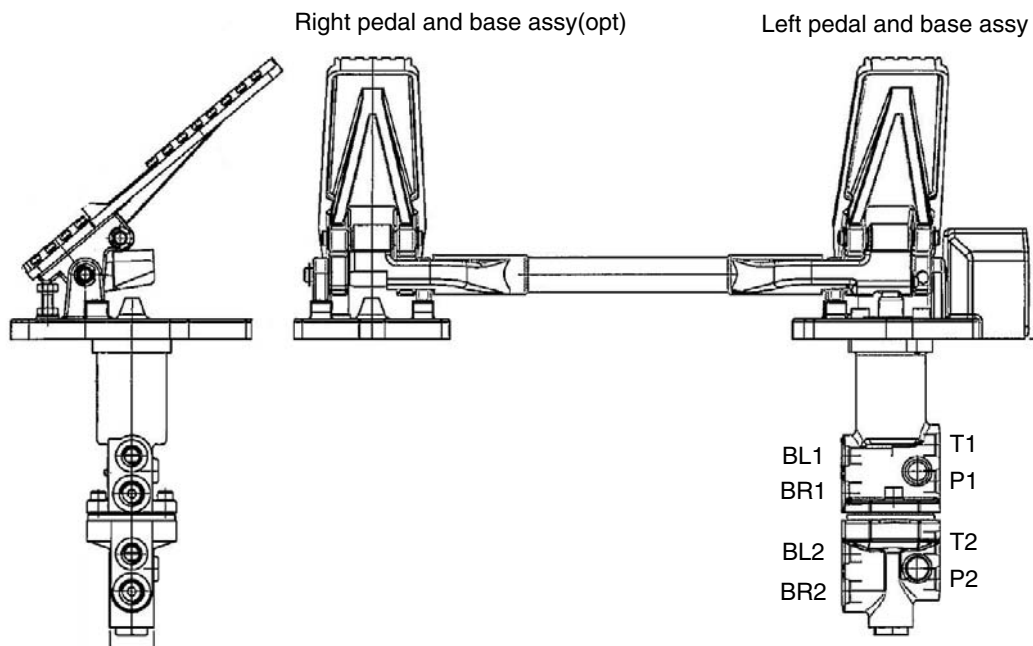

970A4BS08

Port	Port name	Port size
P1, P2	Pressure port	PF 3/8
T1, T2	Return port	PF 3/8
BR1, BR2	Brake cylinder port	PF 3/8
BL1, BL2	Pressure switch port	PF 1/4

- Brake pressure specification : 80 ± 5 bar (1160 ± 70 psi)

2) OPERATION

(1) Purpose

The purpose of the brake valve is to sensitively increase and decrease the braking pressure when the brake pedal is actuated.

(2) Ready position

When the braking system is ready for operation, its accumulator pressure acts directly on ports (P1, P2) of the brake valve. A connection is established between ports (BR1, BR2) and ports (T1, T2) so that the wheel brakes ports (BR1, BR2) are pressureless via the returns ports (T1, T2).

(3) Partial braking

When the brake valve is actuated, an amount of hydraulic pressure is output as a ratio of the foot force applied.

The spring assembly beneath base is designed in such a way that the braking pressure changes depending on the angle. In the lower braking pressure range, the machine can be slowed sensitively.

When the braking process is commenced, the upper spool is mechanically actuated via spring assembly, and the lower spool is actuated hydraulically by spool. As spools move downward, they will first close returns (T1, T2) via the control edges, thus establishing a connection between accumulator ports (P1, P2) and ports (BR1, BR2) for the wheel brake cylinders. The foot force applied now determines the output braking pressure. The control spools are held in the control position by the force applied (Spring assembly above the spools and the hydraulic pressure below the spool (Balance of forces).

After output of the braking pressure, spools are in a partial braking position, causing ports (P1, P2) and ports (T1, T2) to close and holding the pressure in ports (BR1, BR2).

(4) Full braking position

When pedal is fully actuated, end position of the brakes is reached and a connection established between accumulator ports (P1, P2) and brake cylinder ports (BR1, BR2). Returns (T1, T2) are closed at this point.

When the braking process is ended, a connection is once again established between brake cylinder ports (BR1, BR2) and return ports (T1, T2), closing accumulator ports (P1, P2).

The arrangement of spools in the valve ensures that even if one braking circuit fails the other remains fully operational. This is achieved by means of the mechanical actuation of both spools and requires slightly more pedal travel.

(5) Failure of a circuit

In the event of the lower circuit failing, the upper circuit will remain operational. Spring assembly will mechanically actuate spool.

In the event of the upper circuit failing, the lower circuit will remain operational since the lower spool is mechanically actuated by spring assembly and spool.

(6) Installation requirements

Return lines (T1, T2) must be connected directly to the tank.

The connecting lines must be installed in such a way as to permit proper bleeding.

(7) Maintenance of the brake valve

No special maintenance beyond the legal requirements is necessary.

When using high-pressure cleaners on the machine, please make sure that the water jet is not aimed directly at the brake valve (to prevent damaging the bellows).

△ **For safety reasons the whole of the brake valve must be replaced if parts other than those listed above are damaged.**

(8) Repair work

△ When working on the braking system, always make sure that there is absolutely no pressure in the system. Even when the engine is switched off there will be some residual pressure in the system.

※ When doing repair work, make sure your environment is very clean.
Immediately close all open ports on the components and on pipes using plugs.

(9) Replacing the complete actuating mechanism

Carefully clamp the unit vertically in a fixture. The actuating mechanism can be removed by taking out the three bolts. Make sure that spring assembly does not fall out. When installing the new actuating mechanism, make sure that spring assembly is fitted in the right order.

Tighten the three bolts.

5. CUT-OFF VALVE

1) STRUCTURE

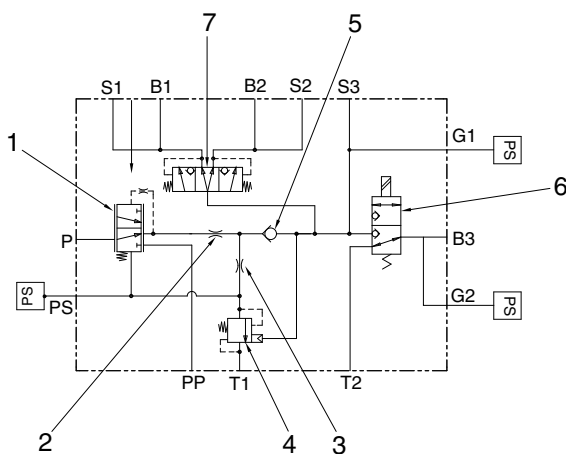
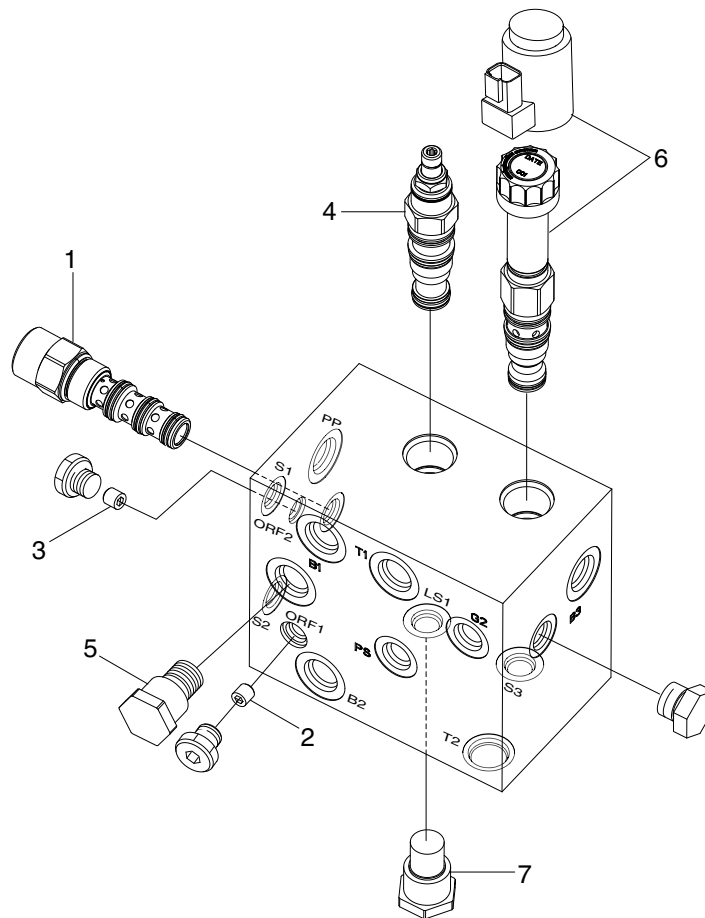

Hydraulic circuit

- 1 Priority valve
- 2 Orifice
- 3 Orifice
- 4 Pressure control valve
- 5 Check valve
- 6 Coil, Solenoid valve
- 7 Directional valve

970A4BS32

2) OPERATION

The pressure control valve (4) controls the minimum and maximum pressure of the braking system. When the service brake pressure is below the maximum pressure (125 ± 5 bar), the pressure control valve (4) is blocked and PS pilot pressure (brake priority pressure) increases.

As soon as PS pilot pressure raises up above 15 bar, pump controller current is reduced by MCU (pressure sensor detects brake priority pressure, and pump supply flow and pressure in order to meet the brake system).

The pressure sensor at PS port detect whether brake system needs to be charged.

Priority valve spring and pilot pressure (brake priority pressure) pushed priority spool to the upward.

Therefore, full pump flow directly goes to the brake system in order to satisfy the demand of the brake system.

Pump flow goes through the following components : orifice (2), check valve (5), directional valve (7). Brake failure pressure sensor at G1 port detects pressure in the brake accumulators.

When the pressure is lower than 100 bar, the sensor activates warning lamp on the cluster in order to check brake system.

When brake system pressure reaches the maximum brake system pressure ($150 \text{ bar} \pm 5 \text{ bar}$), pressure control valve (4) opens, pilot pressure (brake priority pressure) of priority valve is low by draining the spring side of priority valve (1) to hydraulic tank through valve (4).

6. BRAKE ACCUMULATOR

1) STRUCTURE

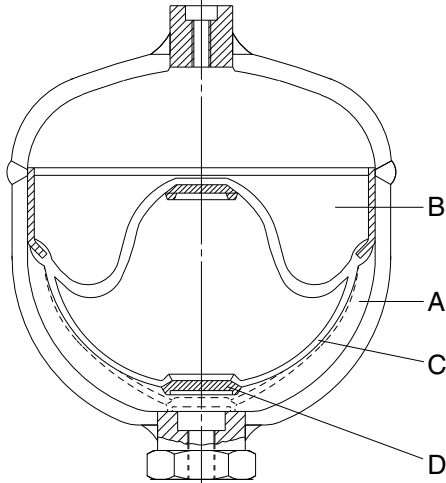

Item	31LL-40020 (item24)	31AC-10030 (item23)
Diameter	167 mm	136 mm
Mounting height	219 mm	159 mm
Norminal volume	2.0 ℓ	1.0 ℓ
Priming pressure	50 kgf/cm ²	50 kgf/cm ²
Operating medium	Oil	Oil
Operating pressure	Max 210 kgf/cm ²	Max 200 kgf/cm ²
Thread	M22 × 1.5	M22 × 1.5
Priming gas	Nitrogen	Nitrogen

A Fluid portion C Diaphragm
 B Gas portion D Valve disk

75794BS09

2) OPERATION

(1) Purpose

Fluids are practically incompressible and are thus incapable of accumulating pressure energy. In hydropneumatic accumulators, the compressibility of a gas is utilized to accumulate fluid. The compressible medium used in the accumulators is nitrogen.

In braking systems, the purpose of the accumulators is to store the energy supplied by the hydraulic pump. They are also used as an energy reserve when the pump is not working, as a compensator for any losses through leakage, and as oscillation dampers.

(2) Operation

The accumulator consists of a fluid portion (A) and a gas portion (B) with a diaphragm (C) as a gas-tight dividing element. The fluid portion (A) is connected to the hydraulic circuit, causing the diaphragm accumulator to be filled and the gas volume to be compressed as the pressure rises.

When the pressure falls, the compressed gas volume will expand, thus displacing the accumulated pressure fluid into the circuit.

The diaphragm bottom contains a valve disk (D) which, if the diaphragm accumulator is completely empty, closes the hydraulic outlet, thus preventing damage to the diaphragm.

(3) Installation requirements

The accumulators can be fitted in the hydraulic circuit, directly on a component or in blocks on suitable consoles.

They should be fitted in as cool a location as possible.

Installation can be in any position.

(4) Maintenance of the accumulator

No special maintenance beyond the legal requirements is necessary.

The accumulator should be checked annually. It should be replaced if the initial gas pressure has fallen by more than 30% (please refer to Performance testing and checking of the accumulator).

(5) Disposal of the accumulator

Before the accumulator is scrapped, its gas filling pressure must be reduced. For this purpose, drill a hole through gas chamber (B) using a drill approx. 3mm in diameter. The gas chamber is located on the side opposite the threaded port above the welding seam around the center of the accumulator.

※ Wear safety goggles when doing this job.

(6) Performance testing and checking of the accumulator

The accumulator is gradually pressurized via the test pump; until the initial gas pressure is reached, the hydraulic pressure in the accumulator will rise abruptly. This is apparent from gauge **M**. If the initial gas pressure is more than 30% below the prescribed value, the accumulator needs to be replaced. If the measuring process needs to be repeated, wait for intervals of 3 minutes between the individual tests. Any accumulator whose initial gas pressure is insufficient must be scrapped following the instructions under **Disposal of the accumulator**.

The amount of initial gas pressure can also be checked from the vehicle. Start the vehicle's engine. The pump will now supply oil to the accumulators. Until the initial gas pressure is reached, the hydraulic pressure in the accumulator will rise abruptly. This is apparent from the gauge in the cab. If the initial gas pressure is more than 30% below the prescribed value, that initial pressure lies outside the permissible range for **at least one** of the accumulators fitted in the vehicle. This accumulator can be traced only by using the method described above, i.e. all accumulators have to be individually tested. The accumulator whose initial gas pressure is insufficient must be replaced and scrapped following the instruction under **Disposal of the accumulator**.

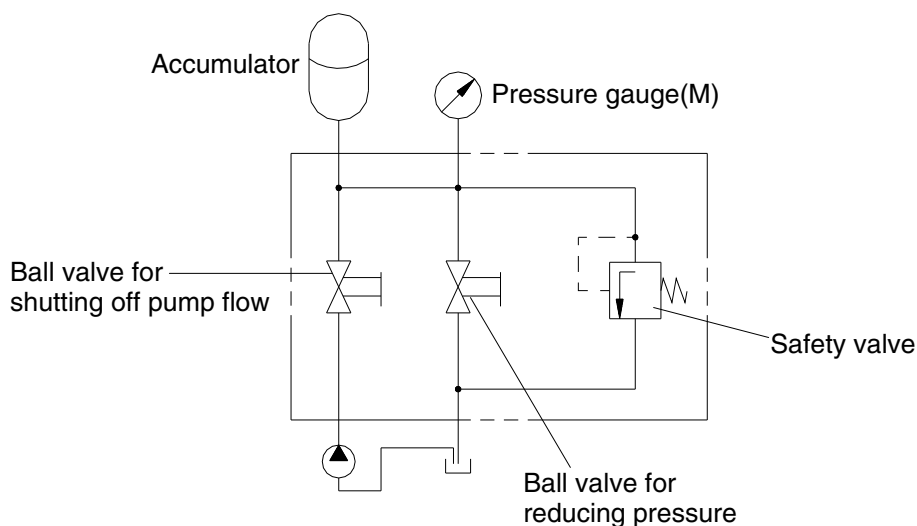

75794BS10

(7) Repair work

△ When working on the braking system, always make sure that there is absolutely no pressure in the system. Even when the engine is switched off there will be some residual pressure in the system.

※ When doing repair work, make sure your environment is very clean.

Immediately close all open ports on the components and on pipes using plugs.

△ For safety reasons the accumulators need to be replaced as a whole if damaged.

7. PRESSURE SENSOR AND SWITCH

1) STRUCTURE

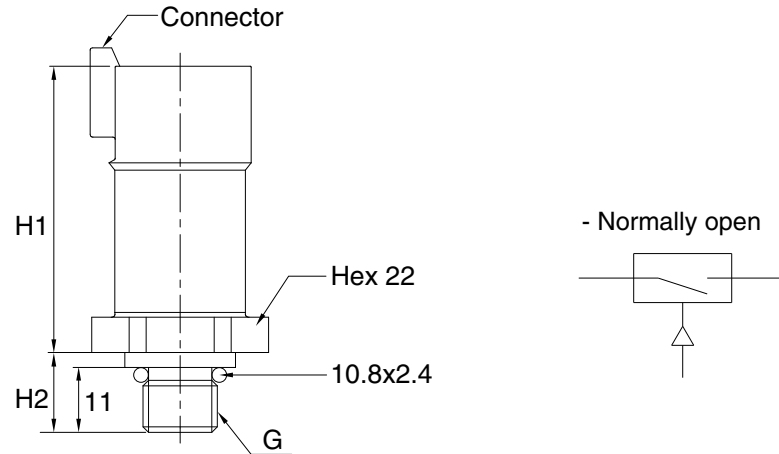

7609A4BS12

2) TECHNICAL DATA

Item	Type	Medium	G	H1 mm	H2 mm	Adjusting range kgf/cm ²	Actuating pressure kgf/cm ²	Voltage V
Parking pressure sensor	-	Oil	PF 1/4"	45	12.5	0 ~ 200	100 ± 5	Max 30
Charging pressure sensor	-	Oil	PF 1/4"	45	12.5	0 ~ 200	100 ± 5	Max 30
Brake priority pressure sensor	-	Oil	PF 1/4"	45	12.5	0 ~ 200	100 ± 5	Max 30
Brake stop pressure switch	NO	Oil	PF 1/4"	45	12.5	1 ~ 10	5 ± 1	Max 32

NO : Normally open

3) Tightening torque : 3.5 kgf · m (25.3 lbf · ft)

2) OPERATION

(1) Purpose

The pressure switches are used to visually or audibly warn the driver of the pressure within the system.

(2) Make contact / circuit closer

The pressure switch can be fitted in the braking system or directly on one of its components.

The system pressure acts on an absorption area within the switch, making an electrical contact as the pressure on that area is increased. The resulting current is used to activate a warning facility, for instance.

(3) Break contact / circuit breaker

The pressure switch can be fitted in the braking system or directly on one of its components.

The system pressure acts on a absorption area within the switch, breaking an electrical contact as the pressure on that area is increased. The current is now broken, e.g. to deactivate a warning facility.

(4) Installation requirements

No special measures need to be taken.

(5) Maintenance of the pressure switch

No special maintenance beyond the legal requirements is necessary.

When using high-pressure cleaners on the vehicle, please make sure that the water jet is not directed at the pressure switch (corrosion of contacts).

(6) Repair work

△ When working on the braking system, always make sure that there is absolutely no pressure in the system. Even when the engine is switched off there will be some residual pressure in the system.

※ When doing repair work, make sure your environment is very clean.

Immediately close all open ports on the components and on pipes using plugs.

※ For safety reasons the pressure switch needs to be replaced as a whole if damaged.

8. PARKING BRAKE SYSTEM

1) STRUCTURE

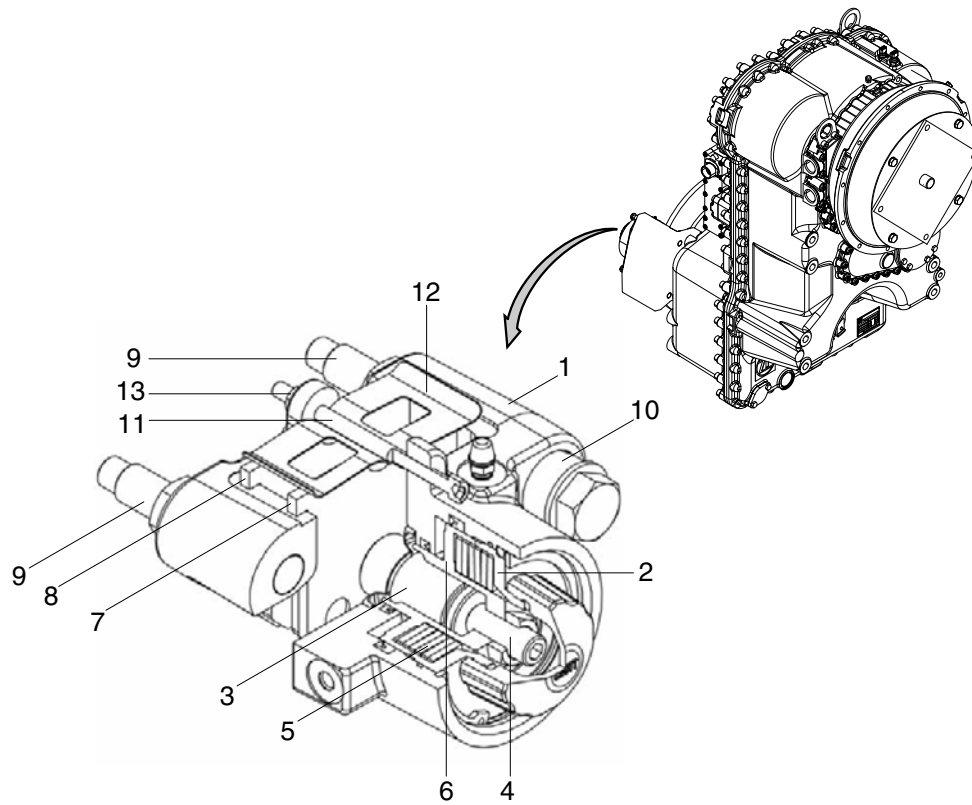

7609A4BS21

- | | | | | | |
|---|-------------------|----|---------------|----|-----------------|
| 1 | Housing | 6 | Piston | 11 | Adjusting screw |
| 2 | Pressure ring | 7 | Lining pad | 12 | Lining spring |
| 3 | Pressure bolt | 8 | Lining pad | 13 | Counter nut |
| 4 | Setting screw | 9 | Guiding pin | | |
| 5 | Plate spring pack | 10 | Rubber buffer | | |

2) OPERATION

The two identical lining pads (7, 8) slide on the guide surfaces on the top of the housing and are held in position by a lining spring (12). The brake itself is directly fixed on the gearbox with the two guide pins (9).

The brake is positioned axially using the rubber buffers (10) between the brake housing (1) and the guide pins (9), and the setting screw (11).

When the brake is actuated (= closed) a clamping force is created on the lining pads (7, 8) which is transmitted to the brake disc. Under the force of the plate spring pack (5), the piston (6), together with the adjusting screw (4), the pressure bolt (3) and the lining pad (7) are moved towards the brake disc. When the lining pad (7) comes into contact with the brake disc, the reaction force displaces the brake on the guide pins (9), against the spring force of the rubber buffers (10), until the second lining pad (8) is also pressed against the brake disc.

The braking effect (braking torque) is dependent upon the frictional values of the brake linings.

The brake is released by complete pretensioning of the plate spring pack (5). The piston (6) is moved back by the required minimum release pressure to the stop on the pressure ring (2).

During this process the brake positions itself, depending upon the setting, by the two rubber buffers (10) up to contact with the setting screw (11). An equal air gap must be guaranteed on both sides of the brake disc when set correctly.

The clamping force is reduced by wear of the lining pads (7, 8) and the brake disc.

The brake must then be readjusted.

3) FITTING AND SETTING INSTRUCTIONS

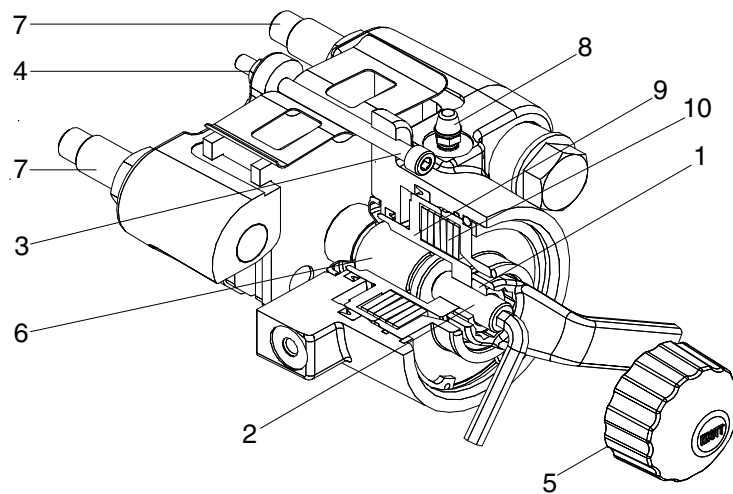

7609A4BS22

- | | | | | | |
|---|-----------------|---|----------------|----|-------------|
| 1 | Lock nut | 5 | Screw cap | 9 | Piston |
| 2 | Setting screw | 6 | Pressure bolt | 10 | Spring pack |
| 3 | Adjusting screw | 7 | Guiding bolt | | |
| 4 | Counter nut | 8 | Bleeding screw | | |

※ The fitting or adjusting must always be carried out when the brake is cold.

(1) Fitting the brake

- ① Rotate the screw cap (5) in a counter-clockwise direction and unscrew it.
- ② Release the lock nut (1) and turn the adjusting screw (2) counter-clockwise until the pressure bolt (6) contacts the piston (9) with the flat surface.
- ③ Slide the brake over the brake disc in this condition.
- ④ Screw the two guide pins (7) into the gearbox in accordance with the fitting instructions. Refer to page 3-171.
- ⑤ Connect the pressure.
- ⑥ Apply the required release pressure (min. 130 bar) to the brake in order to pre-tension the plate spring pack (10) completely, up to the stop.
- ⑦ Carry out bleeding of the brake using the bleed valve (8) .

(2) Clearance adjusting

① Insert a setting gauge on both sides between the brake lining carrier and brake disc and hold them in position.

※ **The thickness of the setting gauge must be adjusted to the desired air gap.**

Clearance		Setting gauge
Min.	0.5 mm	0.25 mm
Nominal clearance	1.0 mm	0.50 mm
Max.	1.5 mm	0.75 mm

② Turn the adjusting screw (2) in a clockwise direction until the two setting gauges are clamped between the brake lining carriers and the brake disc.

③ Hold the adjusting screw (2) in position and lock using the lock nut (1).

※ **The application pressure for clamping the setting gauges must be selected so that both gauges can be removed using a small amount of force after locking in position.**

④ Release the counter nut (4) and then turn the setting screw (3) in a clockwise direction until the end surface of the setting screw (3) is in contact with the surface provided for setting.

⑤ Hold the setting screw (3) in position and lock using the counter nut (4).

⑥ Remove the setting gauges from both sides of the brake disc.

※ **The fitting procedure for the brake and the setting of the desired air gap is now complete. The brake is ready for use.**

⑦ Turn the screw cap (5) in a clockwise direction and tighten hand-tight.

※ **The brake should be actuated and released several times to check that it is functioning properly.**

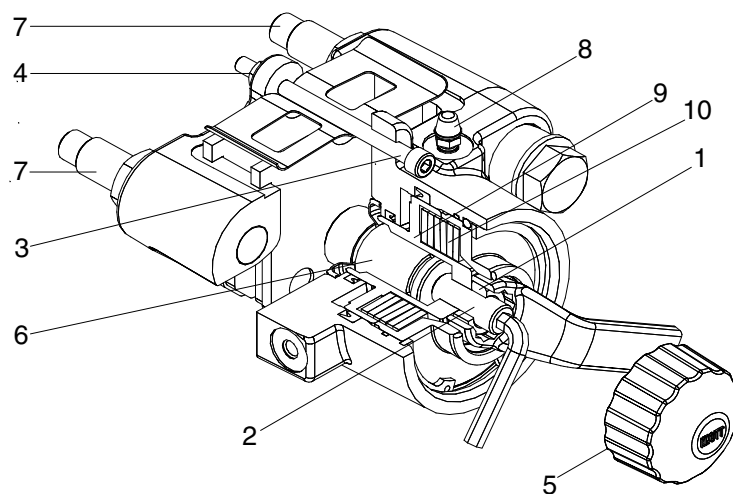

7609A4BS22

(3) Adjusting instructions

- ① Place the machine on flat ground and secure against rolling away.
- ② Release the parking brake by application of the required release pressure (min. 130 bar).
- ③ Rotate the screw cap (5) in a counter-clockwise direction and unscrew it.
- ④ Release the lock nut (1) of the setting screw (2).
- ⑤ Insert a setting gauge on both sides between the brake lining carrier and brake disc and hold them in position.
- ※ **The setting gauge must be selected in accordance with the table under (2) "Clearance adjusting".**
- ⑥ Turn the setting screw (2) in a clockwise direction until the two setting gauges are clamped between the brake lining carriers and the brake disc.
- ⑦ Apply the lock nut (1) to the setting screw (2).
- ※ **The application pressure for clamping the setting gauges must be selected so that both gauges can be removed using a small amount of force after locking in position.**
- ⑧ Release the counter nut (4) and then turn the adjusting screw (3) in a clockwise direction until the end surface of the adjusting screw (3) is in contact with the surface provided for setting.
- ⑨ Hold the adjusting screw (3) in position and lock using the counter nut (4).
- ⑩ Remove the setting gauge from both sides of the brake disc.
- ※ **The adjustment of the desired air gap is now complete. The brake is ready for use.**
- ⑪ Turn the screw cap (5) in a clockwise direction and tighten hand-tight.
- ※ **Actuate the brake valve several times and check the holding effect of the parking brake on a suitable incline or a suitable gradient.**

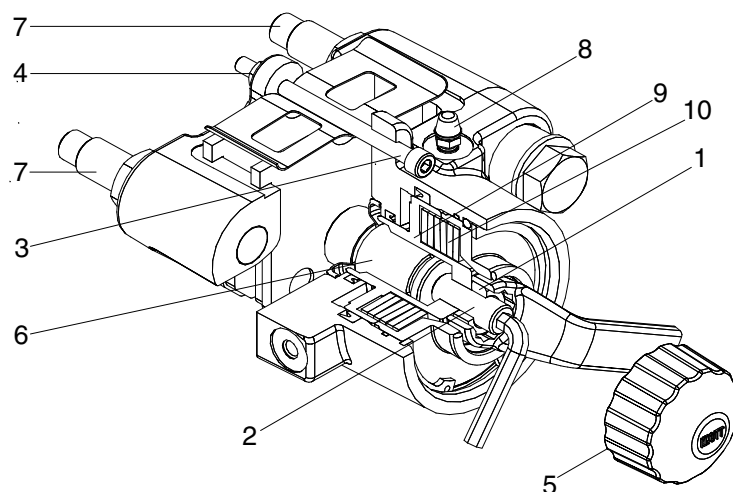

7609A4BS22

4) EMERGENCY RELEASE OF THE PARKING BRAKE

In the event of a failure in pressure supply the parking brake can be released mechanically in the following way :

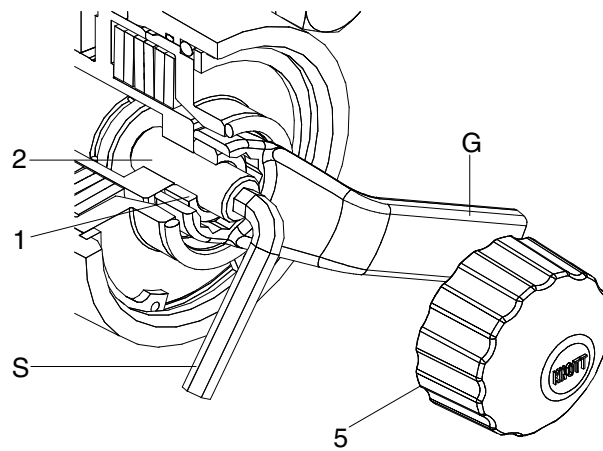

7609A4BS23

- | | | | |
|---|---------------|---|--------------|
| 1 | Lock nut | S | Peg spanner |
| 2 | Setting screw | G | Ring spanner |
| 5 | Screw cap | | |

- (1) Secure the machine against rolling away.
 - (2) Rotate the screw cap (5) in a counter-clockwise direction and unscrew it.
 - (3) Release the lock nut (1) and unscrew it back to the end of the setting screw (2).
 - (4) Rotate the setting screw (2) in a clockwise direction until the brake disc is completely free.
- ※ For emergency release a torque of min 7.1 kgf·m (51.6 lbf·ft) is required on the setting screw (2).
- (5) Screw on the lock nut (1) up to contact with the piston and apply a slight locking force to the setting screw (2).
 - (6) Screw on the screw cap (5) in a clockwise direction by a few threads. (dirt ingress protection)
- ※ In this condition the machine has no parking brake facility and thus must be protected from rolling away by different means. The brake must be adjusted before recommissioning.

5) MAINTENANCE AND REPAIR WORK

(1) Maintenance and replacement of the lining pads

The brake, particularly the brake lining carriers, must be visually inspected at regular intervals. If the remaining lining thickness is too thin, these intervals must be reduced accordingly to prevent extensive damage to the brake or the brake disc.

Once the minimum remaining lining thickness of 1.0 ~ 1.5 mm per brake lining carrier is reached, the brake lining carrier must be replaced in accordance with the following instructions :

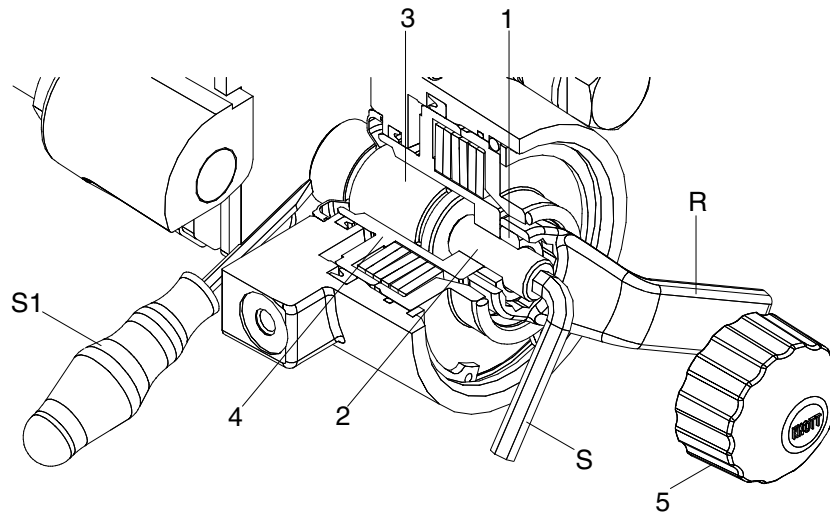

7609A4BS24

- | | | | |
|---|---------------|----|--------------|
| 1 | Lock nut | 5 | Screw cap |
| 2 | Setting screw | S | Peg spanner |
| 3 | Pressure bolt | S1 | Screwdriver |
| 4 | Piston | R | Ring spanner |

- ① Place the machine on flat ground and secure against rolling away.
- ② Release the parking brake by application of the required release pressure (min. 130 bar).
- ③ Rotate the screw cap (5) in a counter-clockwise direction and unscrew it.
- ④ Release the lock nut (1) of the setting screw (2).
- ⑤ Rotate the setting screw (2) in an counter-clockwise direction until the pressure bolt (3) can be pushed completely into the piston (4) .
- ⑥ Unscrew (lever) the pressure bolt (3) with a suitable screwdriver until it contacts the piston (4).

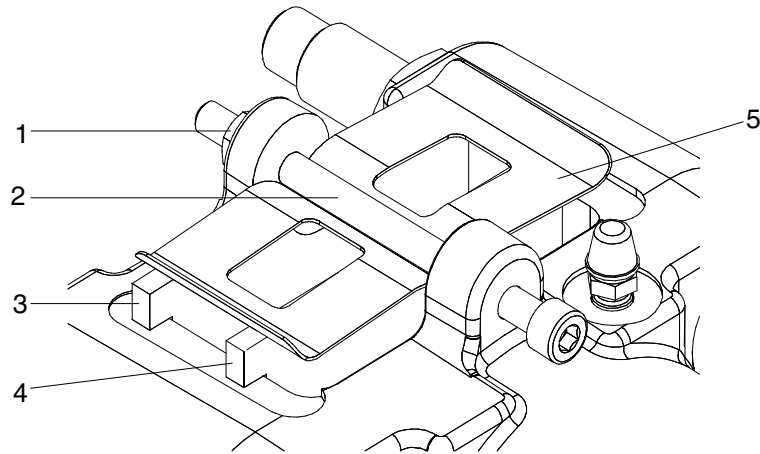

7609A4BS25

- | | | | |
|---|-----------------|---|---------------|
| 1 | Counter nut | 4 | Lining pad |
| 2 | Adjusting screw | 5 | Lining spring |
| 3 | Lining pad | | |

- ⑦ Release the counter nut (1) and unscrew the adjusting screw (2) from the brake housing.
- ※ **The lining spring (5) is pre-tensioned. The lining spring (5) must be held in position with a suitable tool whilst removing the adjusting screw (2).**
- ⑧ Remove the lining spring (5).
- ⑨ Remove the two lining pads (3, 4) from the lining compartment in the brake housing.
- ※ **If there is no possibility of changing the brake lining carriers (3, 4) as described above (not enough space), the brake must be removed completely. The procedure for removing the brake from the gearbox can be taken from the fitting instructions. Refer to page 3-93.**
- ※ **Check the pressure line. A pressure line which is too short must be unscrewed in order to permit removal of the brake.**
An emergency release of the parking brake must be carried out before releasing the pressure line.
- ⑩ Replace the lining pads (3, 4).
- ⑪ The lining spring (5) must be pushed in position with a suitable tool whilst screwing in the adjusting screw (2).
- ※ **If you removed the brake completely because of a lack of space you must carry out fitting of the brake in accordance with the fitting instructions. Refer to page 3-171.**
- ※ **After changing the lining pads (3, 4), or repair to them, the brake must be adjusted in accordance with 3) FITTING AND SETTING INSTRUCTION.**

(2) Replacing the seals

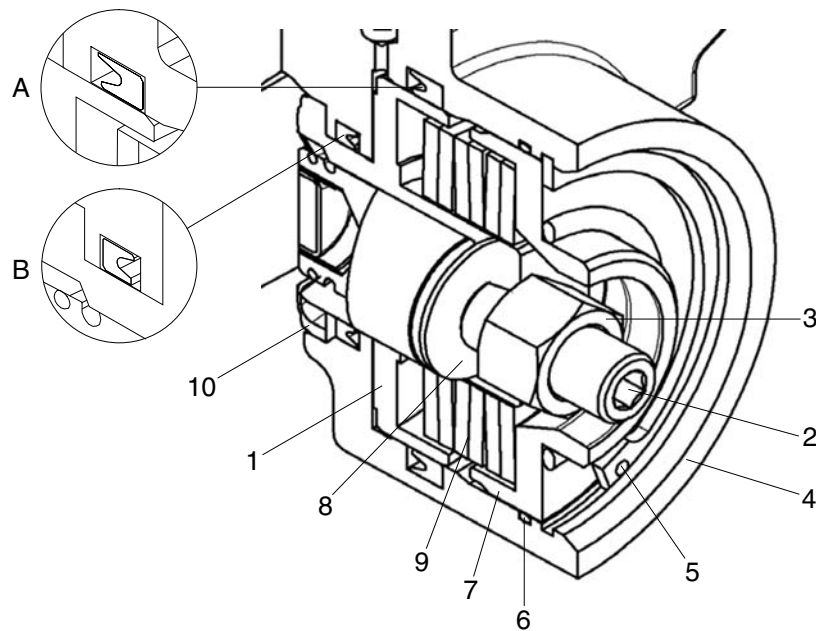

7609A4BS26

1	Piston	5	Circlip	9	Plate spring pack
2	Setting screw	6	Sealring	10	Dust protection cap
3	Lock nut	7	Pressure ring	A	Detail sealing
4	Housing	8	Pressure bolt	B	Detail sealing

Leaking seals must be replaced in accordance with the following instructions :

- ① Place the machine on flat ground and secure against rolling away.
- ② Release the parking brake by application of the required release pressure (min. 130 bar).
- ※ **If the brake cannot be pressurised with the required release pressure (min. 130 bar) because of excessive leaks, the parking brake MUST be released using the emergency procedure. See 4) Emergency release of the parking brake.**
- ③ Rotate the screw cap in a counter-clockwise direction and unscrew it.
- ④ Release the lock nut (3) of the setting screw (2).
- ⑤ Rotate the setting screw (2) in an counter-clockwise direction until the pressure bolt (8) can be pushed completely into the piston (1).
- ⑥ Unscrew (lever) the pressure bolt (8) with a suitable screwdriver until it contacts the piston (1).
- ⑦ Actuate the brake valve and dissipate the existing release pressure down to 0 bar.
- ※ **The plate spring pack (9) is now fully de-tensioned.**
- ⑧ Unscrew the pressure line and remove the brake completely.
- ⑨ Remove the circlip (5) and remove the pressure ring (7) from the housing (4).
- ⑩ Remove the plate spring pack (9) and the piston (1).
- ⑪ Always replace both the seals (A, B).

- ※ Observe the fitting direction of the grooved rings and use a suitable fitting needle with rounded edges to fit the new grooved rings. Take care - there is a danger of injury.
- ※ Carry out re-fitting of the individual parts into the brake in reverse order. Apply a light coat of fitting fluid lubricant to the sliding and sealing surfaces of the piston when fitting.

⑫ If necessary, also replace the dust protection cap (10).

- ※ The dust protection cap (10) has a vulcanised-in steel ring which is used to press it into the opening in the brake housing (4).

In order to replace this you will need to "lever it out" with a suitable tool and then replace with a fitting fixture by pressing it into the housing (4).

⑬ Fit the brake onto gearbox in accordance with the fitting instructions. Refer to page 3-171.

(3) General instructions

Any faults or damage detected on parts not listed here must, of course, be rectified or replaced by genuine parts.

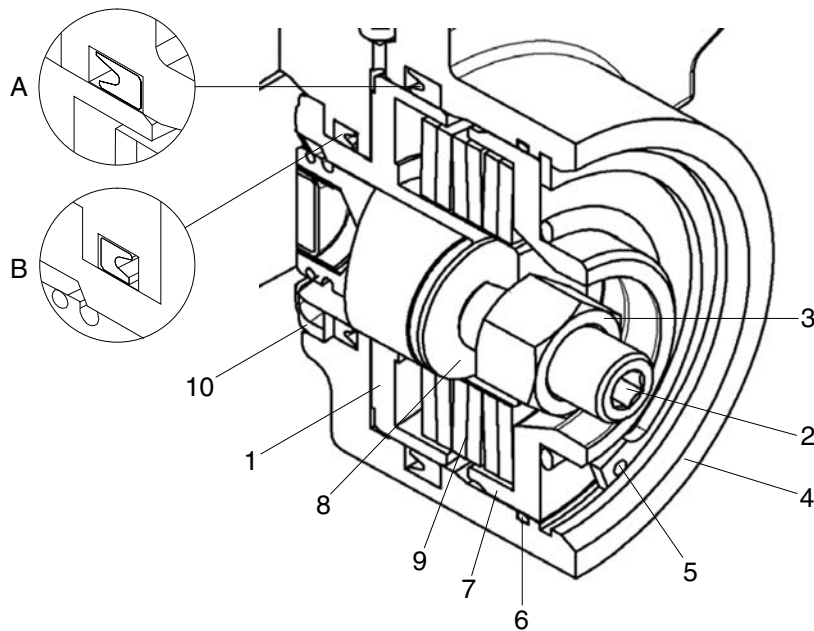

7609A4BS26

MEMORANDUM

GROUP 2 OPERATIONAL CHECKS AND TROUBLESHOOTING

1. OPERATIONAL CHECKS

This procedure is designed so the mechanic can make a quick check of the system using a minimum amount of diagnostic equipment. If you need additional information, read **structure and function**, Group 1.

A location will be required which is level and has adequate space to complete the checks.

The engine and all other major components must be at operating temperature for some checks.

Locate system check in the left column and read completely, following the sequence from left to right. Read each check completely before performing.

At the end of each check, if no problem is found (OK), that check is complete or an additional check is needed. If problem is indicated (NOT OK), you will be given repair required and group location.



If verification is needed, you will be given next best source of information:



Chapter 2 : Troubleshooting

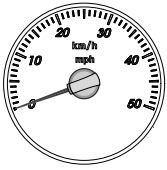
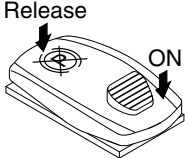
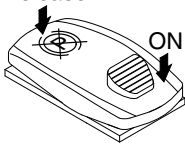
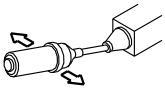

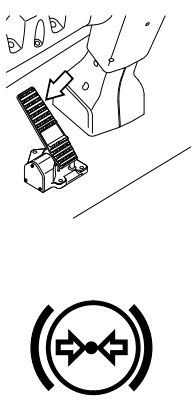
Group 3 : Tests and adjustments

※Hydraulic oil must be at operating temperature for these checks (refer to page 6-49).

Item	Description	Service action
<p>Parking brake capacity check Seat belt must be worn while doing this check to prevent possible injury when machine stops suddenly.</p>	 <p>Start engine. Fasten seat belt. Release parking brake and put transmission in 2nd gear forward. Drive machine at 8 km/hr and switch parking brake ON. LOOK/FEEL : Machine must come to a stop within 2 meters (6 feet) when parking brake is engaged at 8 km/hr. Transmission must shift to neutral.</p> 	<p>OK Check completed.</p> <p>NOT OK Inspect parking brake. Go to group 3.</p>
<p>Parking brake transmission lockout check Engine running.</p>	  <p>Turn parking brake to ON. Place transmission in 1st forward. Slowly increase engine speed to high idle. LOOK : Machine must not move.</p>	<p>OK Check completed.</p> <p>NOT OK Go to transmission control circuit in section 3.</p>

Item	Description	Service action
<p>Service brake pump flow check</p> <p>※ Hydraulic oil must be at operating temperature for the check.</p> <p>Engine OFF.</p>	 <p>Stop engine.</p> <p>Operate brake pedal approximately 20 times.</p> <p>Start engine and run at low idle.</p> <p>Record number of seconds required for low brake pressure indicator lamp to go out.</p> <p>LOOK : Indicator lamp must go out in less than 4 seconds from time engine starts.</p> <p>NOTE : Indicator will not come on approximately 1 second after starting engine.</p>	<p>OK Check completed.</p> <p>NOT OK Check for brake circuit leakage.</p> <p>Go to next page.</p> <p>IF OK Install a cap on line connected to inlet of brake valve and repeat pump flow check.</p> <p>If time does not decrease, check for worn brake pump.</p>
<p>Service brake capacity check</p> <p>Engine running.</p>	 <p>Select clutch cut-off mode to OFF.</p> <p>Apply service brakes, release park brake and put transmission in 2nd forward.</p> <p>Increase engine speed to high idle.</p> <p>LOOK : Machine may not move or move at a very slow speed.</p> <p>Repeat check three times to ensure accurate results.</p>	<p>OK Check completed.</p> <p>NOT OK Check brake pressure.</p> <p>IF OK Inspect brake disk.</p>

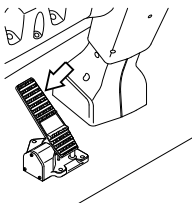
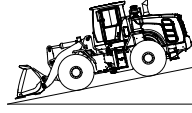
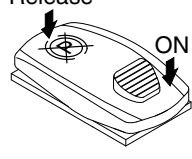
Item	Description	Service action
<p>Brake accumulator precharge check</p> <p>※ The axles and hydraulic oil must be at operating temperature for this check.</p>	<div style="display: flex; flex-direction: column; align-items: center;">   </div> <p>Start and run engine for 30 seconds.</p> <p>Stop engine and turn start switch to ON and wait 5 seconds.</p> <p>NOTE : Engine oil pressure lamp will be on due to no engine oil pressure.</p> <p>Count the number of times the brake pedal can be fully depressed before the low brake pressure warning lamp comes ON.</p> <p>LOOK : Warning lamp must come ON in 1~5 applications.</p> <p>Start engine and operate at low idle.</p> <p>Observe cluster while applying brake pedal with maximum force.</p> <p>LOOK/LISTEN : Brake pressure indicator must not come ON.</p>	<p>OK Check completed.</p> <p>NOT OK Make sure brake pedal is not binding and keeping brakes partially engaged.</p> <p>Bleed brakes in group 3.</p> <p>Check brake system pressure.</p> <p>NOT OK If light comes ON with engine running, accumulator has lost it's charge. Inspect and recharge accumulator.</p>
<p>Brake system leakage check</p>	<div style="display: flex; flex-direction: column; align-items: center;">  </div> <p>Start engine and wait 30 seconds.</p> <p>Stop engine.</p> <p>Wait 2 minutes.</p> <p>Turn start switch to ON and wait 5 seconds.</p> <p>LOOK : Brake oil pressure warning lamp must not come ON within 2 minutes after stopping engine.</p>	<p>OK Check completed.</p> <p>NOT OK If brake leakage is indicated with brakes released, check leakage at accumulator inlet check valve and brake valve. If brake leakage is indicated with brakes applied, check for leakage at brake valve and brake pistons.</p> <p>Check individual component leakage.</p>

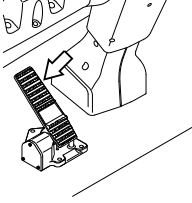
Item	Description	Service action
Service brake pedal check	 <p>Slowly depress brake pedal.</p> <p>Listen for a hissing noise that indicates oil is flowing to brake pistons.</p> <p>LISTEN/FEEL : A hissing noise must be heard when pedal is depressed.</p>	<p>OK Check completed.</p> <p>NOT OK Inspect for debris under brake pedal.</p>
Service and parking brake system drag checks Engine running	 <p>Position machine on gradual slope.</p> <p>Lower bucket approximately 50 mm (2 in) from ground.</p> <p>Release parking and service brakes.</p>  <p>LOOK : Machine must move or coast.</p> <p>NOTE : If machine does not move, check brake pedals to be sure they fully release when feet are removed from pedals.</p> <p>Drive machine at high speed for about 5 minutes.</p> <p>Brake drag is indicated if brake areas in differential case are hot.</p> <p>NOTE : Observe parking brake.</p> <p>If disk is hot, parking brake drag is indicated.</p>	<p>OK Check completed.</p> <p>NOT OK Adjust park brake.</p> <p>NOT OK Check floor mat interference to pedal or debris build-up.</p> <p>IF OK Check for brake pressure when brake is released.</p> <p>Go to brake pressure test.</p>
Clutch cut-off check	 <p>Select clutch cut-off mode to L mode.</p> <p>Release parking brake.</p> <p>Run engine at half speed in 1st forward.</p>  <p>Firmly depress brake pedal.</p> <p>FEEL : Transmission must disengage when brake pedal is depressed at 30% of pedal stroke.</p> <p>NOTE : Clutch cut-off mode can be selected to operator preference to match your loading needs.</p>	<p>OK Check completed.</p> <p>NOT OK Adjust clutch cut-off mode.</p>

2. TROUBLESHOOTING

1) SERVICE BRAKE

Diagnose malfunction charts are arranged from most probable and simplest to verify, to least likely, more difficult to verify. Remember the following steps when troubleshooting a problem :

Step 1. Operational check out procedure (see section 1)

Step 2. Operational checks (in this group)

Step 3. Troubleshooting

Step 4. Tests and adjustments (see group 3)

Problem	Cause	Remedy
Poor or no brakes	Brake accumulator charge low. Brake pump standby pressure low. Brake pressure low. Air in system. Worn brake surface material. Leakage in brake valve. Leakage in brake piston seal.	Do brake accumulator check. Do brake pump standby pressure test. Do brake valve pressure test. Bleed brakes. Inspect brake surface material. Do brake valve leakage test. Check for an over filled differential. Apply brakes and check for leakage from check plug. ※ It is normal for the oil level to be slightly above the check plug.
Aggressive brakes	Internal restriction in circuit. Brake valve malfunction. Low oil level.	Remove lines and components. Disassemble and inspect. Check oil level.
Brakes drag	Brake pedal not returning properly. Debris holding valve partially open in brake valve. Warped brake disk. Stuck brake piston.	Inspect floor mat and pedal. Do brake valve pressure test. Inspect brake disk. Repair.
Brakes lock up	Brake valve malfunction.	Clean or replace brake valve.

Problem	Cause	Remedy
Brakes chatter	Air in brake system. Worn brake surface material. Wrong oil in differential.	Do brake bleed procedure. Inspect brake surface material. Drain. Refill.
Hissing noise when brake pedal is held with engine stopped	Leakage in brake valve, or brake piston.	Do brake system leakage test.
Brake pressure warning light will not go out or stays on excessively long after start-up	Malfunction in brake low pressure warning switch. Brake accumulator pressure too low. Low brake pump standby pressure setting. Leakage in pressure reducing manifold block. Leakage in brake system. Worn brake pump. Leakage in parking brake solenoid.	Replace switch. Recharge accumulator. Do brake pump standby pressure test. Do pressure reducing valve manifold leakage test. Do brake system components leakage tests. Do brake pump flow test. Do parking brake pressure test.

2) PARKING BRAKE MALFUNCTIONS

Problem	Cause	Remedy
Brake will not hold	Pads not adjusted correctly. Malfunctioning parking brake solenoid. Worn brake disk and / or brake pads. Brake piston hangs up in bore.	Adjust parking brake. Inspect and replace. Disassemble, inspect, repair. Remove and inspect. Repair.
Brake disk overheats	Pads out of adjustment. Brake not released.	Adjust parking brake. Release parking brake. Disassemble, inspect brake. Repair if necessary. Inspect for loosen or broken lines between brake pressure switch and indicator on dash.
Parking brake indicator in monitor does not come on when brake applied	Faulty wiring or switch.	Inspect for loose or broken lines between brake pressure switch and indicator on dash. Inspect for a faulty indicator on dash. Replace if necessary.
Brake will not apply	Pads out of adjustment. Malfunctioning wiring, switch, or solenoid. Restriction between brake valve and brake.	Adjust parking brake. Check electric circuit. Remove hose and inspect. Replace.

GROUP 3 TESTS AND ADJUSTMENTS

1. PARKING BRAKE PERFORMANCE

1) MEASUREMENT CONDITION

- (1) Tire inflation pressure : Specified pressure
- (2) Road surface : Flat, dry, paved surface with 1/5 (11°20') gradient.
- (3) Machine : In operating condition

Item	Standard value
Parking brake performance	Keep machine on 20% (11°20') gradient

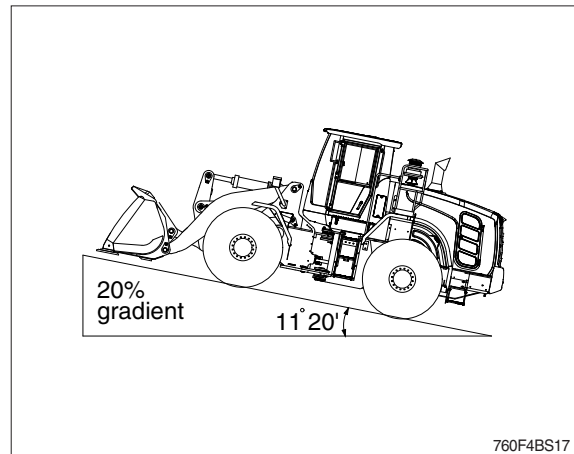

2) MEASURING PROCEDURE

- (1) Start the engine and drive the machine straight up a 1/5 gradient with the bucket unloaded.
 - (2) Depress the service brake, place the gear selector lever in neutral, then stop the engine.
 - (3) Turn the parking brake switch ON, then slowly release the service brake pedal and the machine must be kept stopped.
- ※ The measurement must be made with the machine facing either up or down the slope.

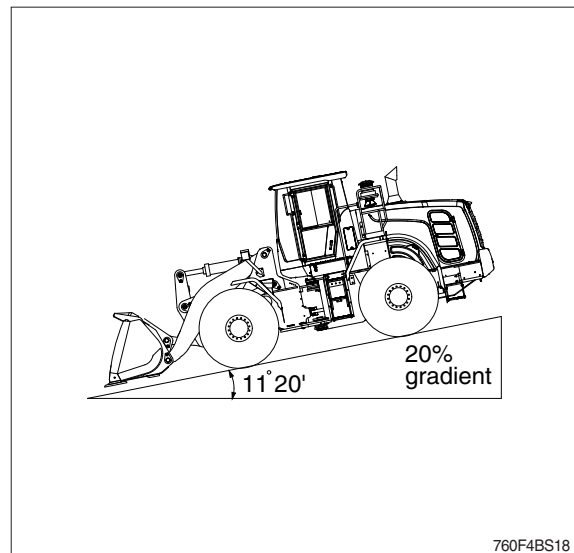

2. ADJUSTMENT OF PARKING BRAKE

- (1) External brake inspection
 - Inspect for wear of brake pad
- (2) Refer to the PARKING BRAKE SYSTEM on the page 4-21.

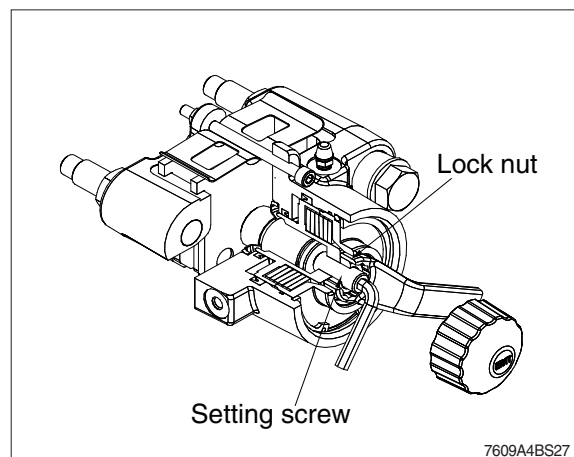

3. HYDRAULIC BRAKE BLEEDING PROCEDURE

▲ Escaping fluid under pressure can penetrate the skin causing serious injury. Avoid the hazard by relieving pressure before disconnecting hydraulic or other lines. Tighten all connections before applying pressure.

Search for leaks with a piece of cardboard. Protect hands and body from high pressure fluids.

※ If an accident occurs, see a doctor immediately. Any fluid injected into the skin must be surgically removed within a few hours or gangrene may result.

Doctors unfamiliar with this type of injury should reference a knowledgeable medical source.

Two people are required to bleed brake system oil, one to operate brake valve and other to open and close bleed screws.

- 1) Install frame locking bar. Engage parking brake.
- 2) Put a clear plastic tube on bleed screw to route low to hydraulic oil tank filler tube or container (A).
- 3) Start engine and run at low idle.
- 4) Push and hold brake pedal down until brake bleeding procedure is complete.
※ If bubbles continue for more than 2 minutes, stop bleeding procedure. Check for and correct problem, then continue.
- 5) Open on bleed screw on differential and axle assembly until hydraulic oil starts to flow. Close bleed screw when oil is free of air. Release brake pedal.
- 6) Repeat steps 1)~5) for each bleed screw.
- 7) Push either brake pedal and hold down.
- 8) Check hydraulic oil level.

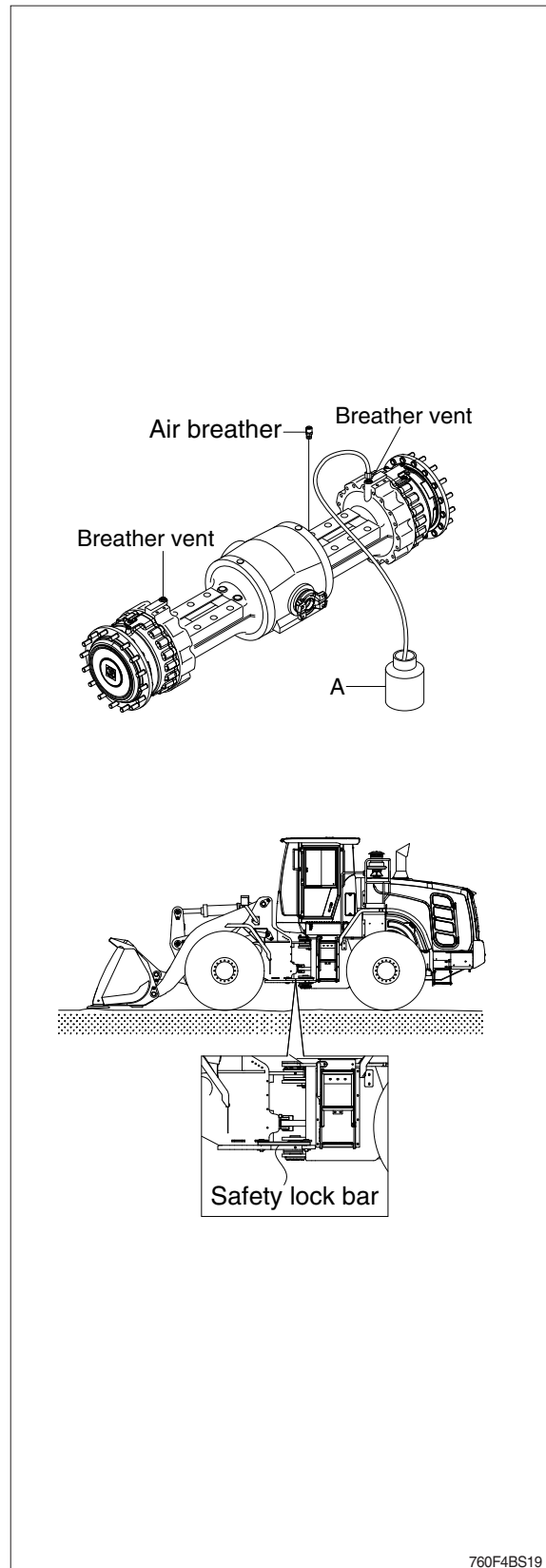

760F4BS19

GROUP 4 DISASSEMBLY AND ASSEMBLY

1. FAN AND BRAKE PUMP

1) STRUCTURE

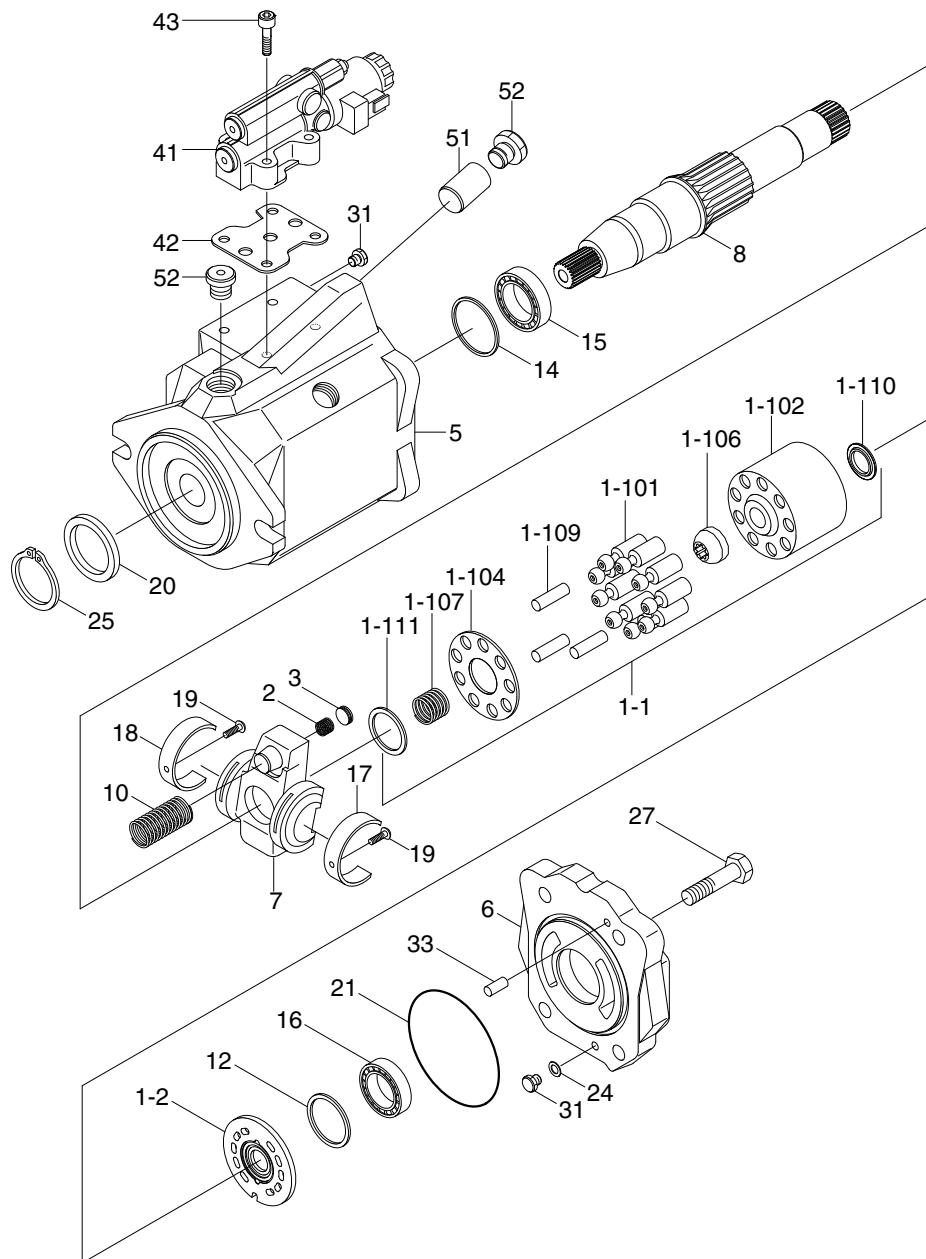

7609A4BS11

1-1	Rotary group	5	Pump housing	20	Shaft seal ring
1-101	Piston	6	Port plate	21	O-ring
1-102	Cylinder	7	Swash plate	24	Kantseal ring
1-104	Retaining plate	8	Drive shaft	25	Retaining ring
1-106	Retaining ball	10	Spring	27	Socket screw
1-107	Spring	12	Adjustment shim	31	Plug
1-109	Pressure pin	14	Stop ring	33	Cylinder pin
1-110	V-ring	15	Tapered roller bearing	41	Control valve
1-111	Back-up plate	16	Tapered roller bearing	42	Gasket
1-2	Control plate	17	Liner bearing	43	Socket screw
2	Pressure spring	18	Liner bearing	51	Control piston
3	Stop	19	Flat screw	52	Locking screw

2) GENERAL REPAIR GUIDELINES

- ※ Observe the following guidelines when carrying out repairs on hydraulic pumps.
- (1) Close off all openings of the hydraulic unit.
- (2) Replace all of the seals.
Use only original spare parts.
- (3) Check all sealing and sliding surfaces for wear.
- ※ Re-work of the sliding surfaces by using, for example abrasive paper, can damage the surface.
- (4) Fill the hydraulic pump with hydraulic oil before commissioning.

3) SEALING THE DRIVE SHAFT

- | | | | |
|---|----------------|---|------------|
| 1 | Retaining ring | 2 | Shaft seal |
| 3 | Bearing | 4 | Stop ring |

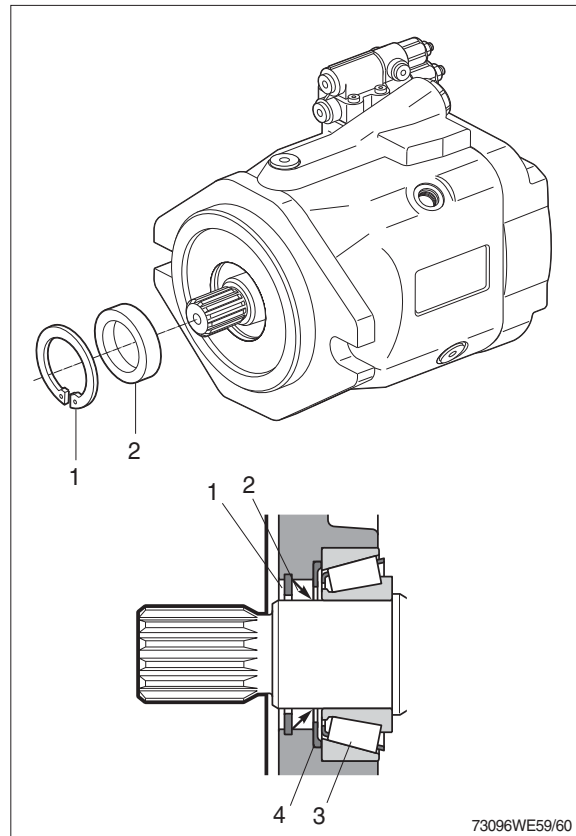

- (1) Protect the drive shaft.
Wrap the drive shaft with tape.
Remove the retaining ring.
Remove shaft seal to front.

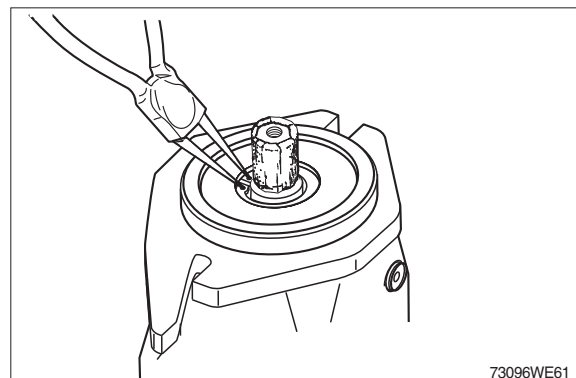

- ※ Change the shaft seal and check its sliding surface (drive shaft) and housing, grease the sealing ring.
Visual check shaft seal and housing.

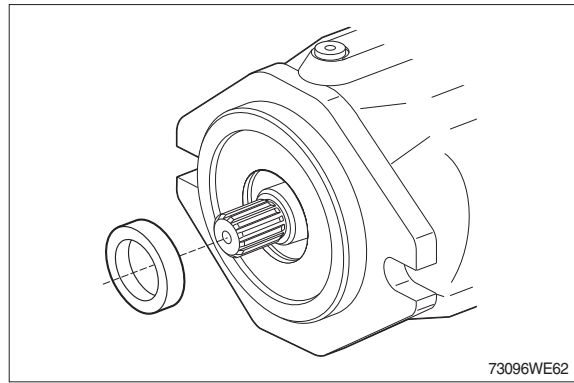

- (2) Assembling of the sealing ring carefully down to the stop ring.

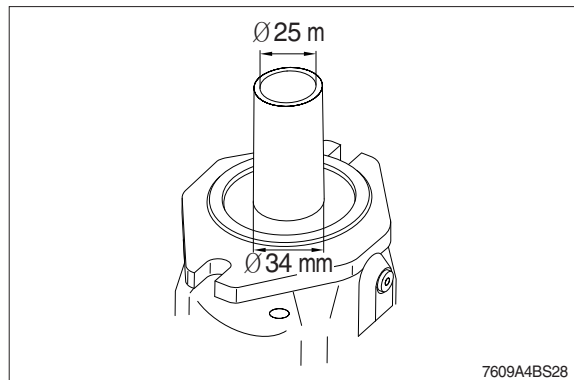

- (3) Assemble the retaining ring (circlip).
- ※ Visual check to ensure that the circlip is correctly located in the groove.

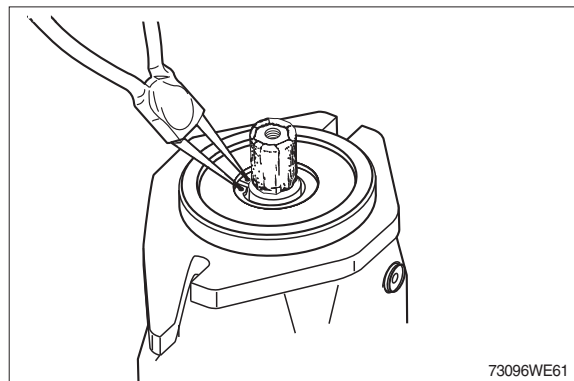

4) SEALING THE CONTROL VALVE

- (1) Remove the control valve.

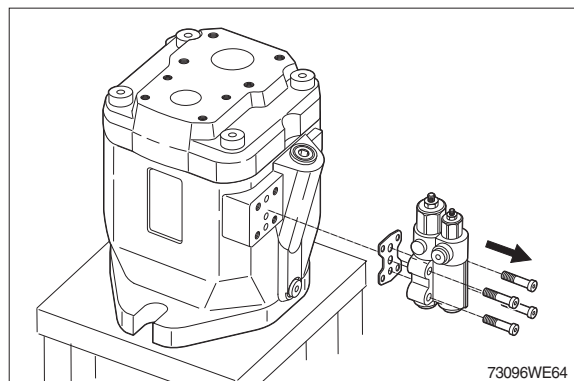

- (2) Measure dimension A and note down.
Check sealing surface (1).
Replace gasket (2).

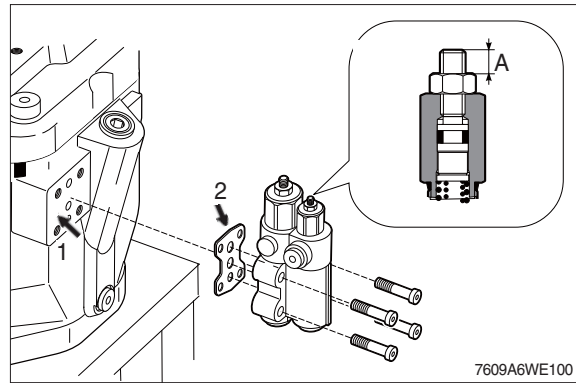

- (3) Assemble control valve.
Tighten the bolts.
· Tightening torque : 1.58 kgf · m
(11.4 lbf · ft)

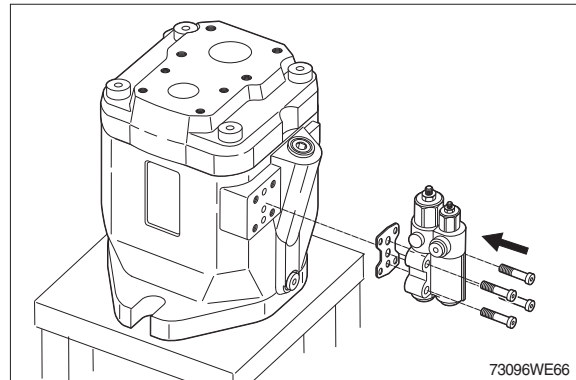

- (4) Check dimension A.

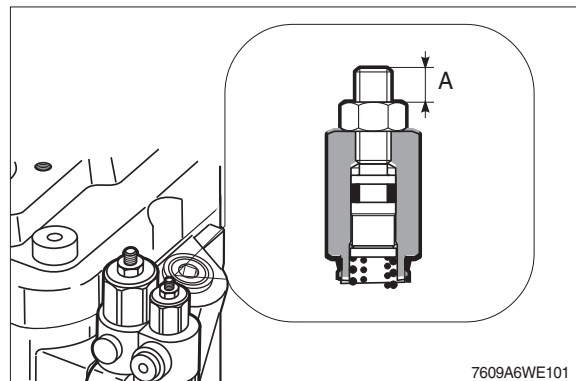

5) INSPECT HINTS

- (1) Renew all bearings.

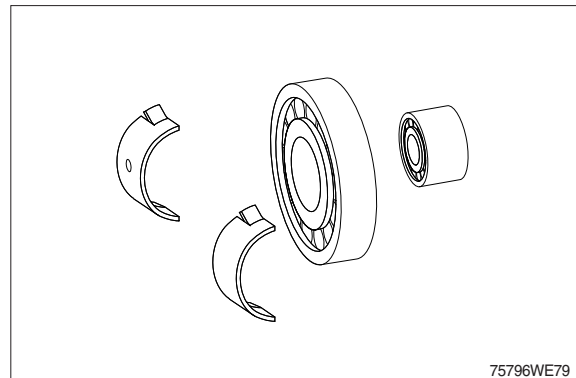

(2) Check :

- 1 Wear on splines, rust
- 2 Drive shaft seal wear grooves
- 3 Bearing seat
- 4 Splines for cylinder drive
- 5 Bearing seat

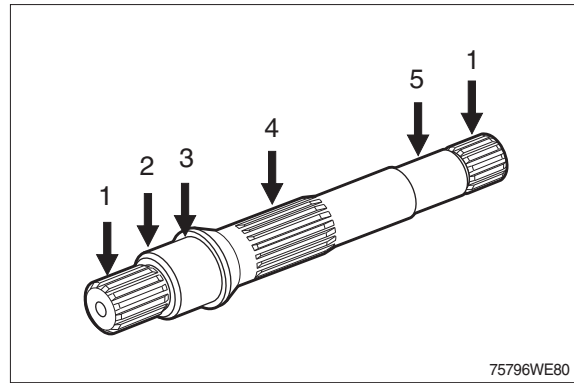

(3) Check :

Sliding surface free of grooves.

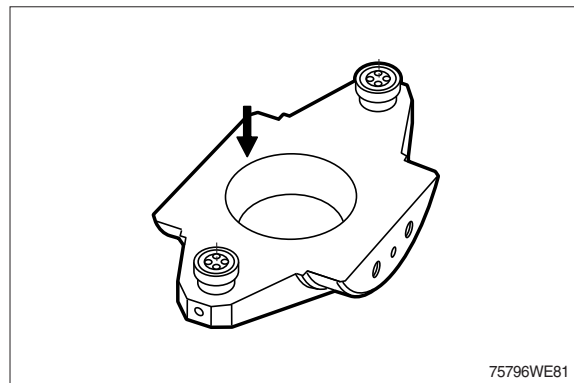

(4) Check :

Bearing surfaces.

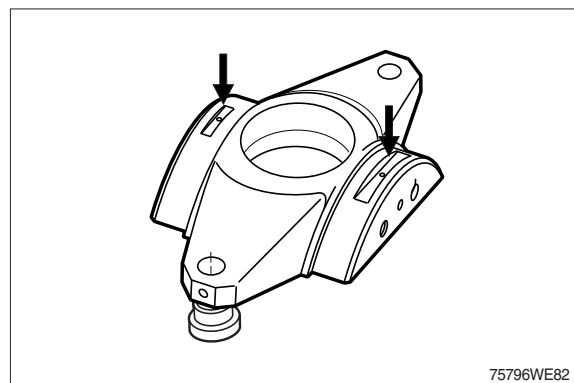

(5) Check :

That the retaining plate is free of grooves and that there is no wear in the slipper pad area.

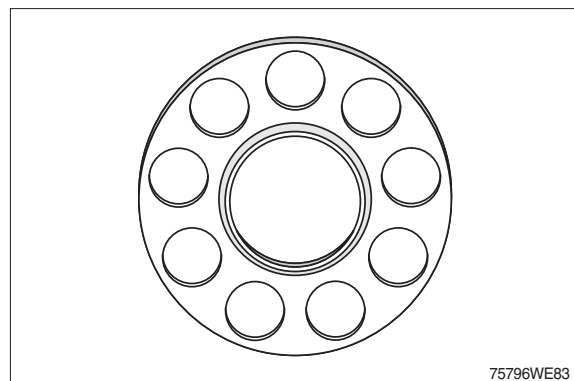

(6) Check :

Check to see that there are no scratches or metal deposits on the sliding surface (1) and that there is no axial play (2) (Pistons must only be replaced as a set).

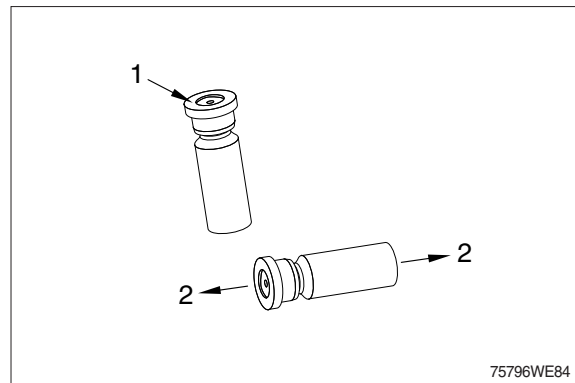

(7) Check :

- 1 Cylinder bores
- 2 Splines

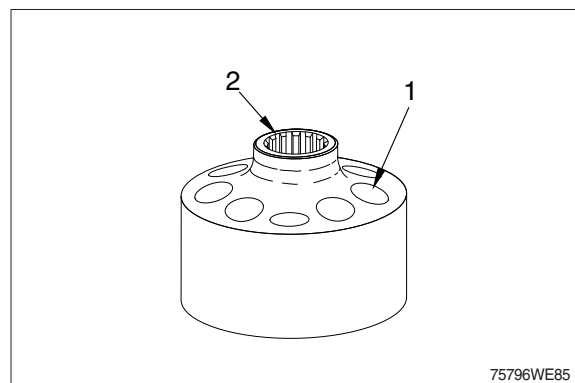

(8) Free of grooves, no signs of wear.

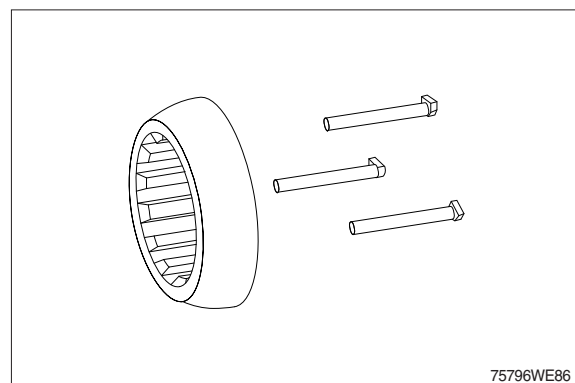

(9) Check :

Cylinder sliding surface free of grooves, no wear, no embedded foreign particles. That there are no scratches on the control plate. (Only replace them as a set).

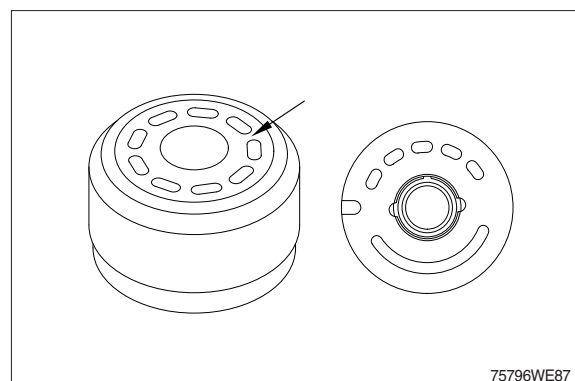

2. FAN MOTOR

1) STRUCTURE

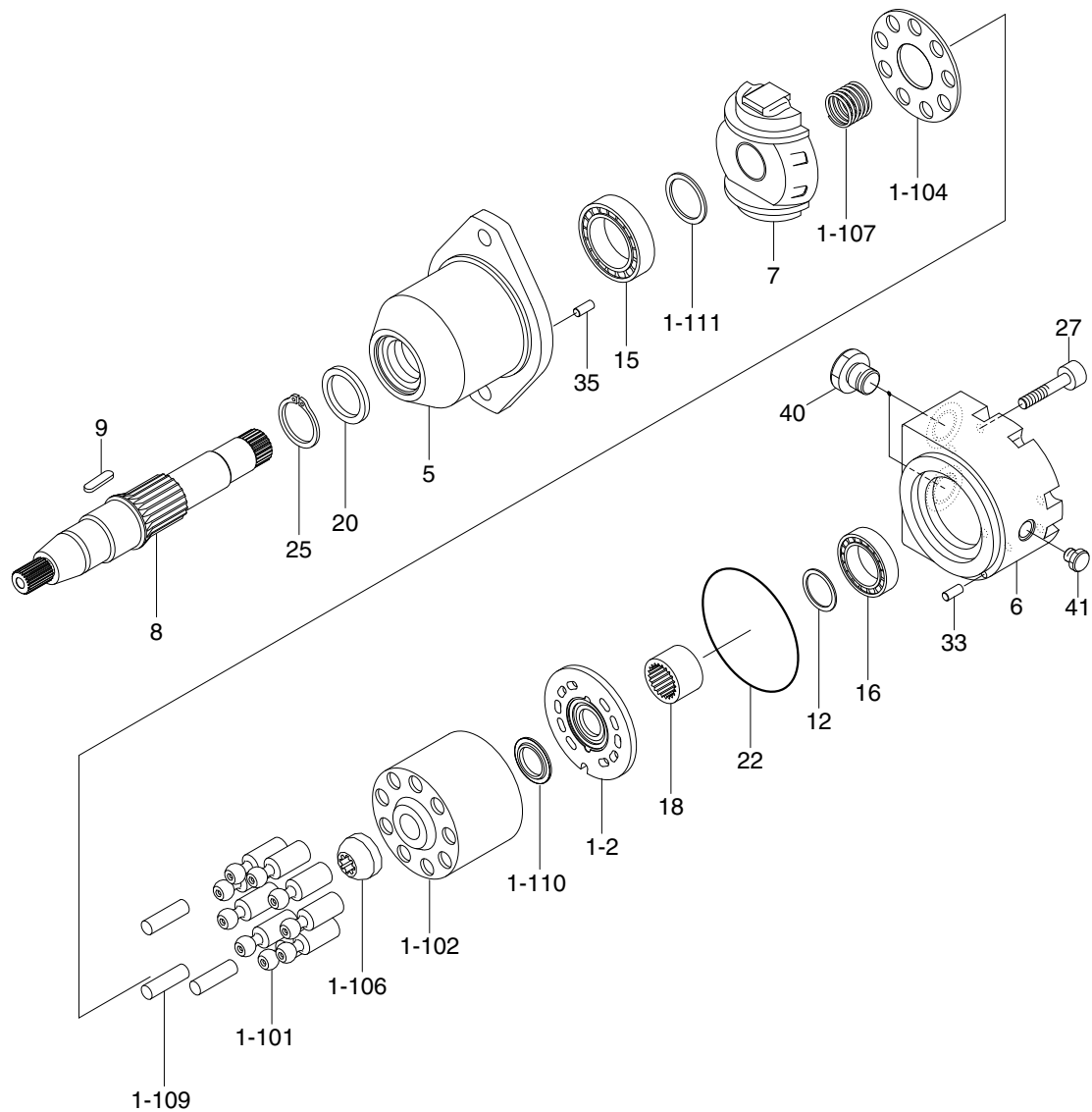

7609A4BS20

1-1	Rotary group	1-2	Control plate	18	Bearing bushing
1-101	Piston	5	Motor housing	20	Shaft seal
1-102	Cylinder	6	Port plate	22	O-ring
1-104	Retaining plate	7	Cam plate (swash plate)	25	Retaining ring (circlip)
1-106	Retaining ball	8	Drive shaft	27	Socket bolt
1-107	Spring	9	Shaft key	33	Cylinder pin
1-109	Pressure pin	12	Adjustment shim	35	Cylinder pin
1-110	V-ring	15	Tapered roller bearing	40	Screw
1-111	Back-up plate	16	Tapered roller bearing	41	Screw

2) SEALING THE DRIVE SHAFT

- (1) 1 Circlip
- 2 Shaft seal

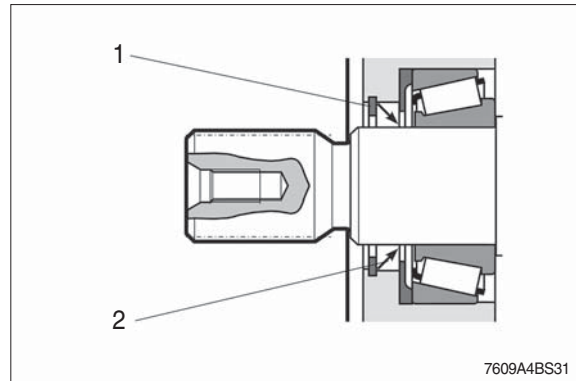

- (2) Remove key.
Protect the drive shaft.
Remove the circlip.

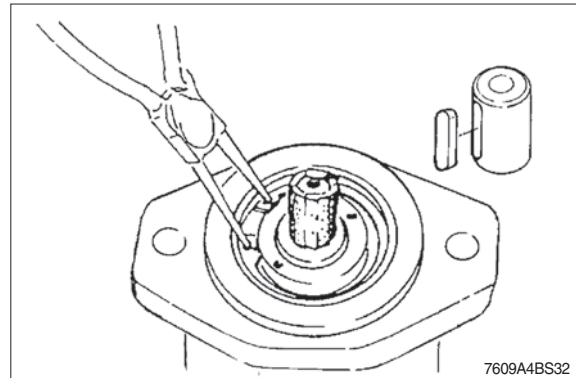

- (3) Change the shaft seal and check its sliding surface (drive shaft) and housing, grease the sealing ring.

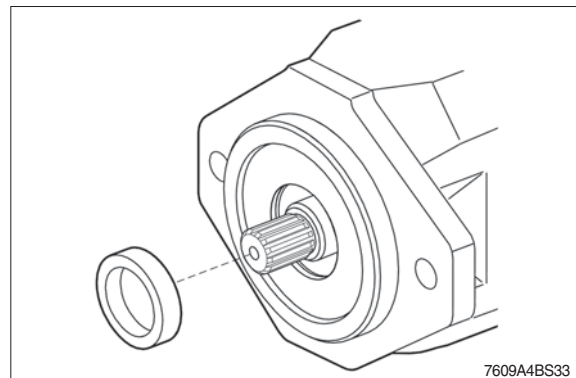

- (4) Use installation tool or plastic strip for assembling seal.

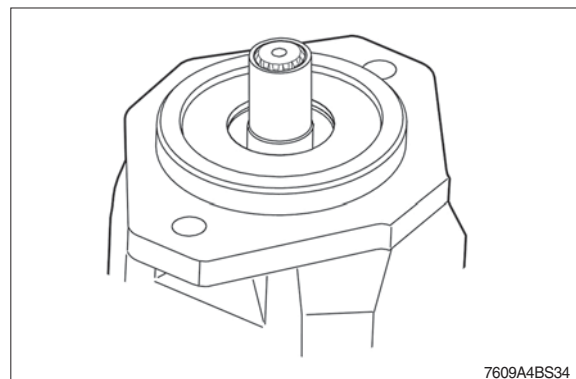

- (5) Use a suitable pipe to mount the shaft seal, but don't push it too deep. If the shaft ring touches the bearing ring you will damage the seal ring.

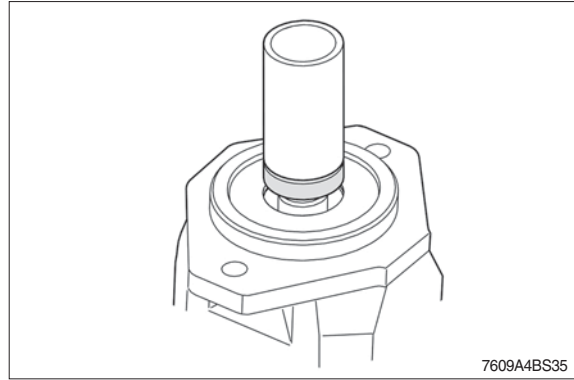

- (6) Assemble the circlip.

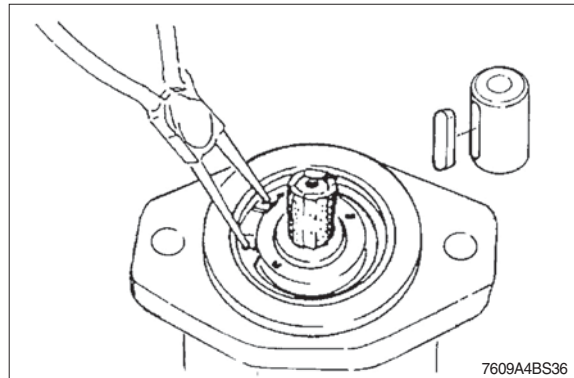

- (7) Assemble the circlip in the correct position.

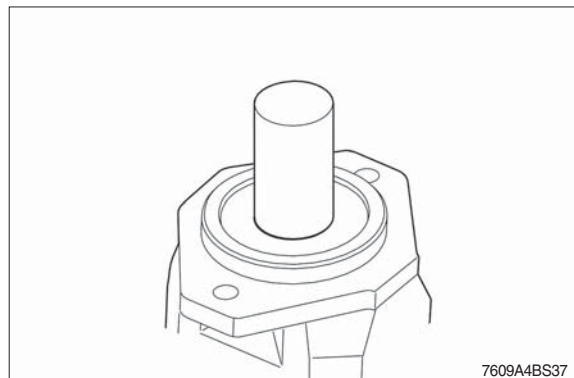

※ This discription shows how th change the drive shaft seal but it isn't the way of serial assembly.

The seal is assembled together with the taper roller bearing from inside the motor housing normally to get a secure sealing condition. If you decide to repair the motor in the shown way be very careful while handling so that the drive shaft wouldn't be damaged during disassembly of the shaft seal.

3) DISASSEMBLE THE MOTOR

- (1) Disassembly position.
Mark the location of the port plate on the housing.

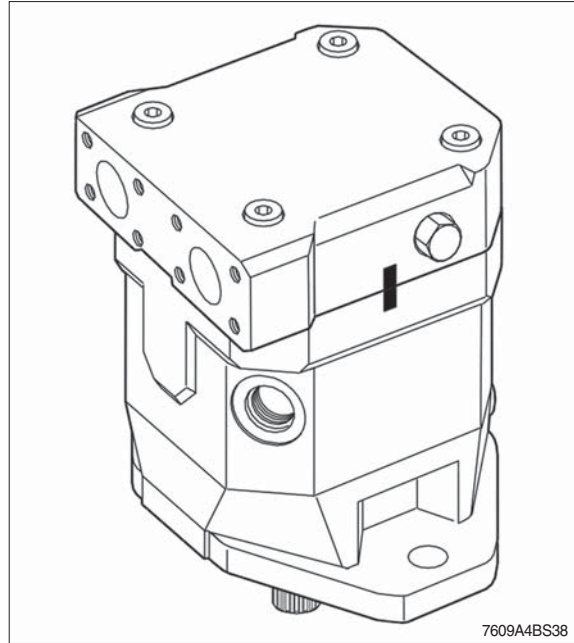

- (2) Remove the port plate fixing bolts crosswise.

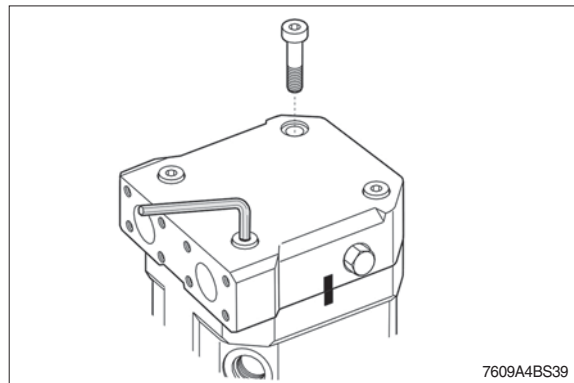

- (3) Remove the port plate.
※ Control plate can drop down-hold tight.

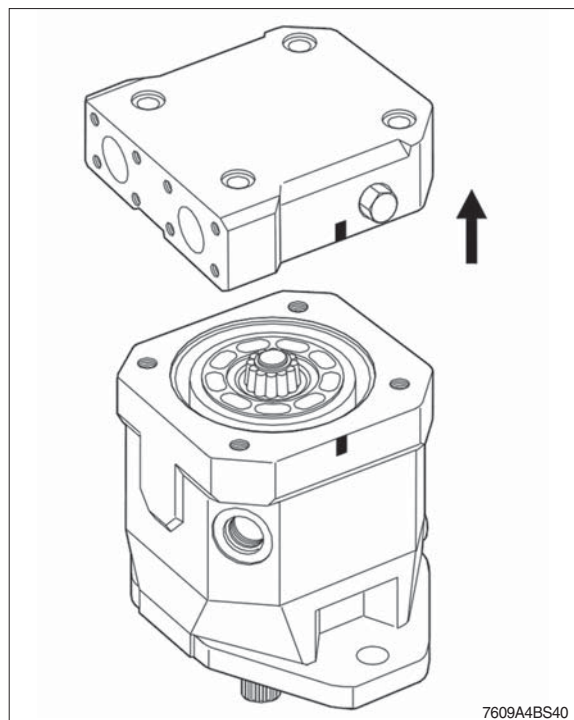

(4) Remove control plate.

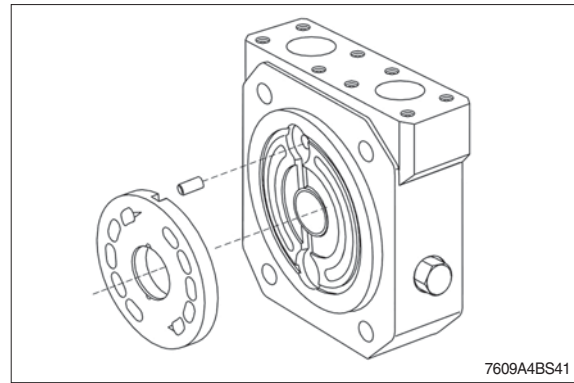

(5) Remove bearing outer ring with withdrawal tool.
Do not damage the sealing surface.

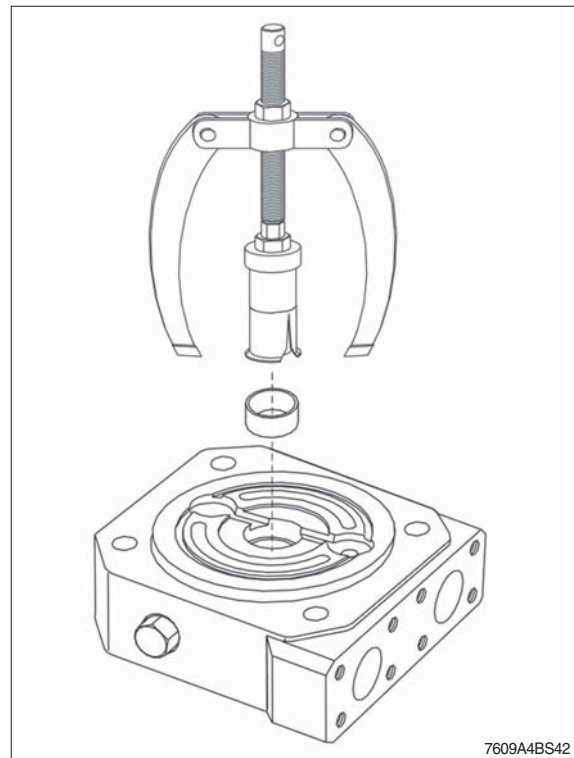

(6) Disassemble the taper roller bearing (near by port plate).
Remove the adjustment shim.

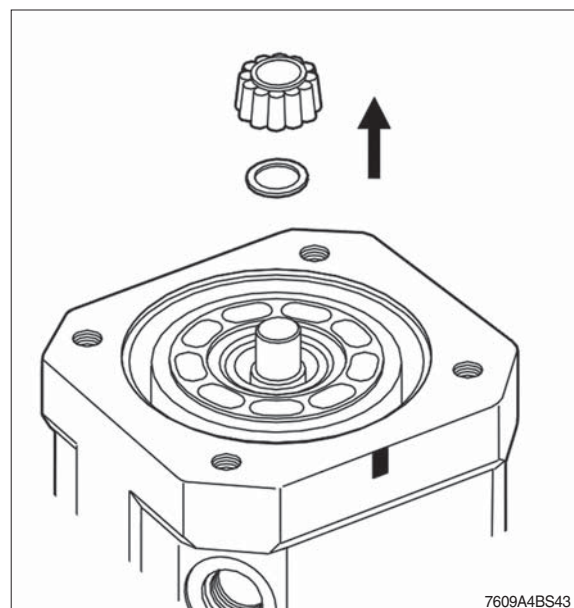

(7) Remove the rotary group in a horizontal position.

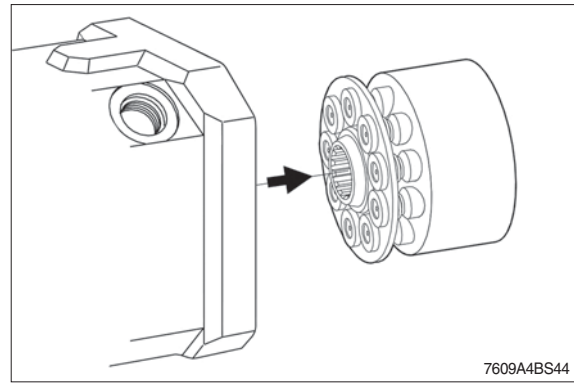

(8) Remove the drive shaft to rear side.

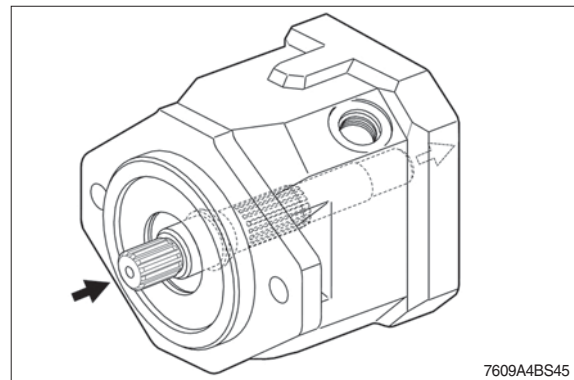

(9) Remove swash plate with special tool (see the next figure).

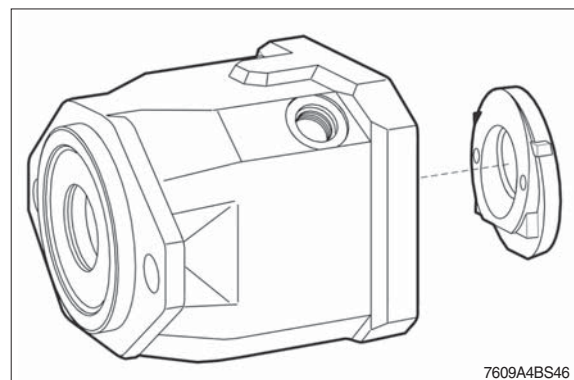

(10) Loosen the swash plate with a slide hammer (a small hook - diameter 6 mm - catches the end of the swash plate at the bottom).

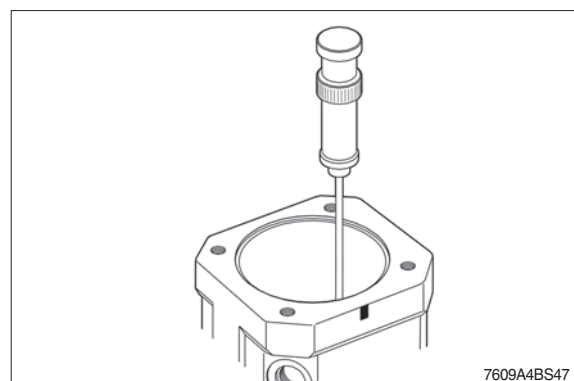

(11) Press down bearing.

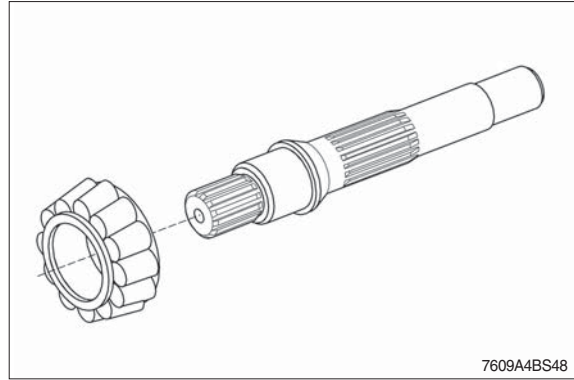

(12) The external front bearing ring is pulled out of the pump housing.

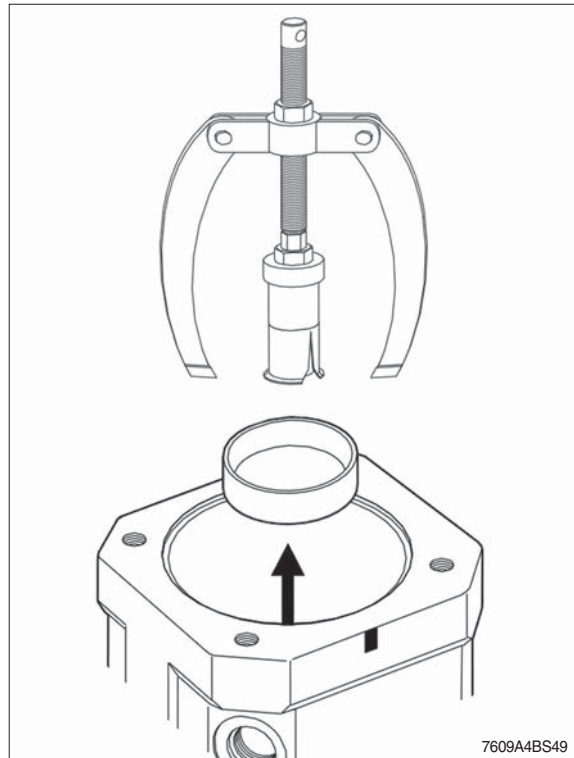

(13) Disassemble circlip and shaft seal.

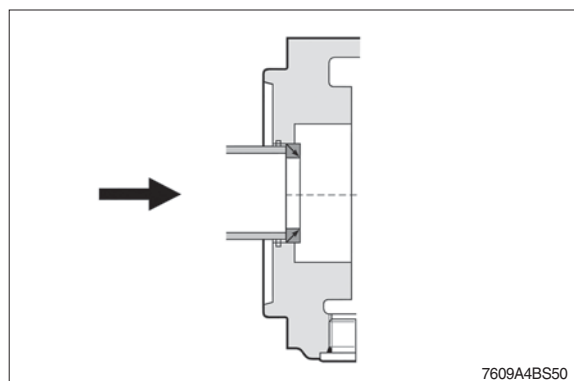

(14) Remove shaft seal and shim.

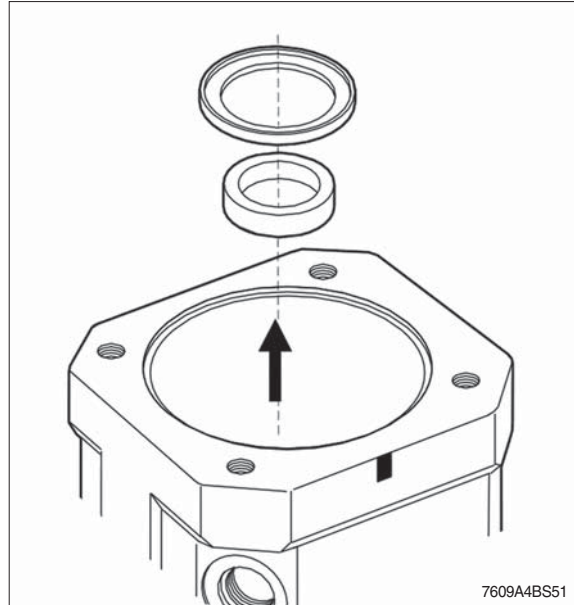

(15) Pre-tension the spring using a suitable device.

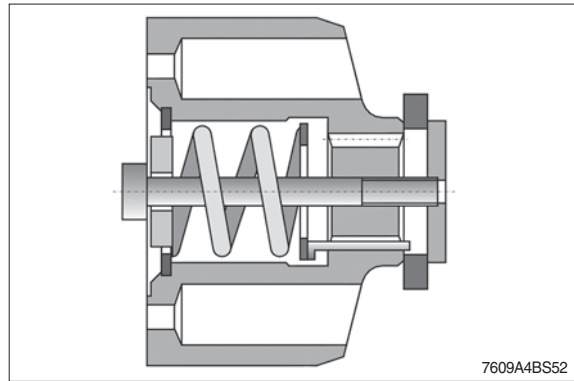

(16) Remove circlip.
Remove spring and pressure pins.

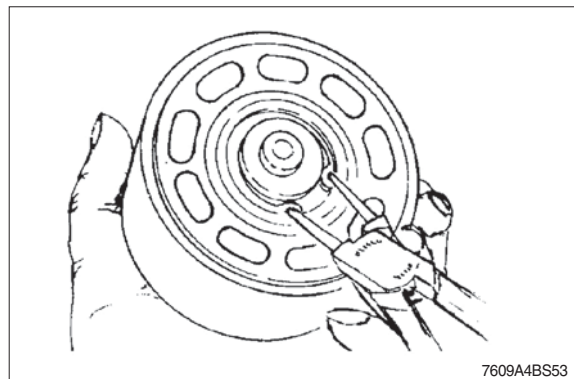

4) INSPECTION HINTS

- (1) Check to see that there are no scratches or metal deposits on the sliding surface (1), and that there is no axial play (2), (pistons must only be replaced as a set).

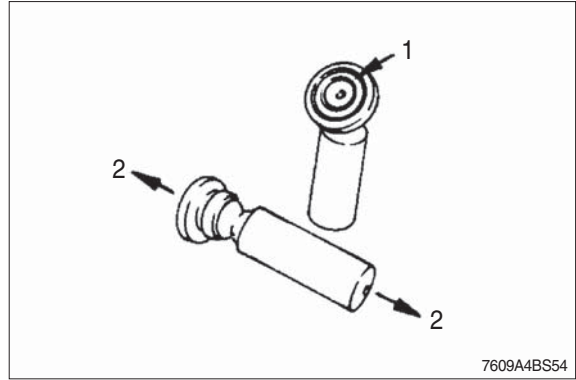

- (2) Check cylinder bores (1) and splines (2).

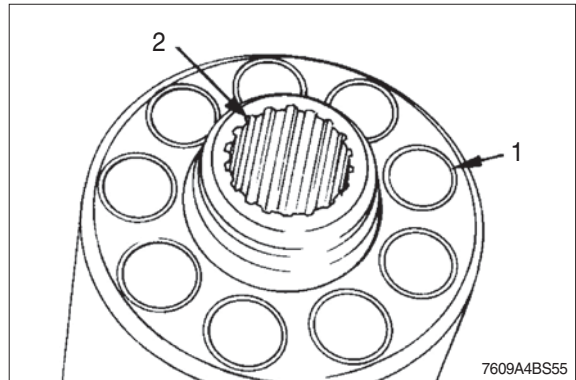

- (3) Free of grooves, no signs of wear.

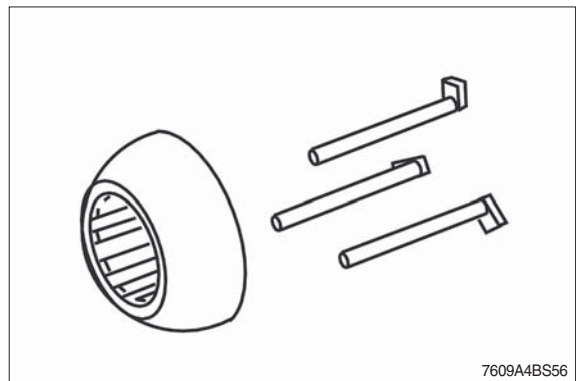

- (4) Cylinder sliding surface free of grooves, no wear, no embedded foreign particles. That there are no scratches on the control plate. (Only replace them as a set).

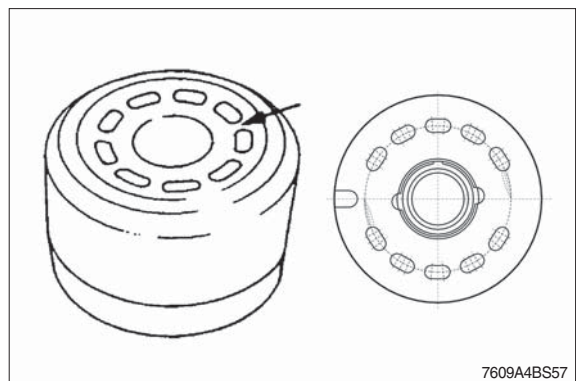

(5) Mounting surface - control plate undamaged.

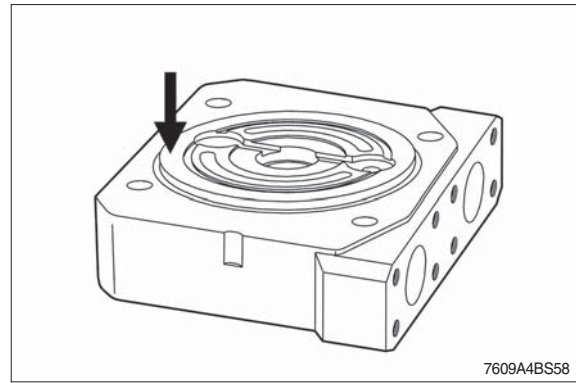

5) MOTOR ASSEMBLY

(1) Fit the circlip into the housing.

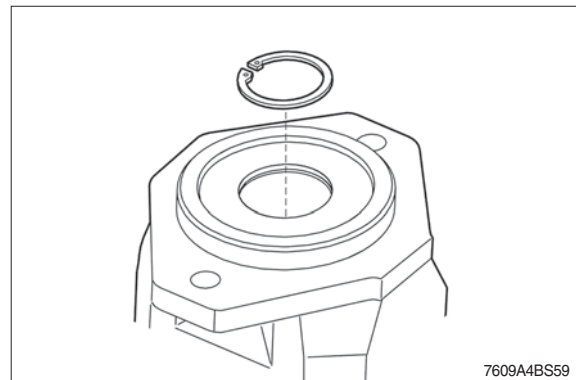

(2) Assemble shaft seal and shim against circlip.

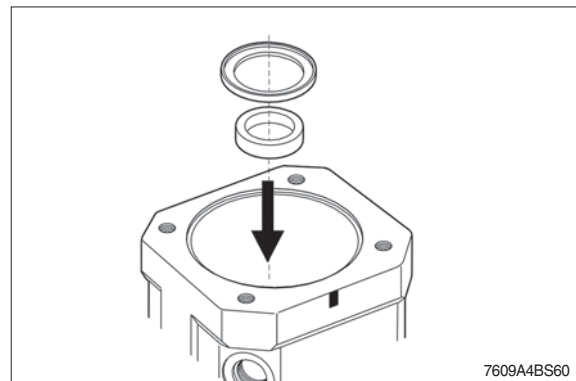

(3) Assembly of the shaft seal (1) against the safety ring (2) back up the shim (3) down to the seal ring.

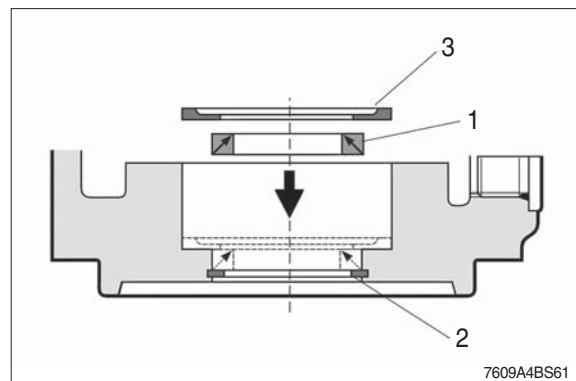

(4) Press outer bearing ring into housing.
Shaft seal with pre-assembled bearing into housing.

※ Protect splines of the shaft with plastic strip against damage of the seal lip.

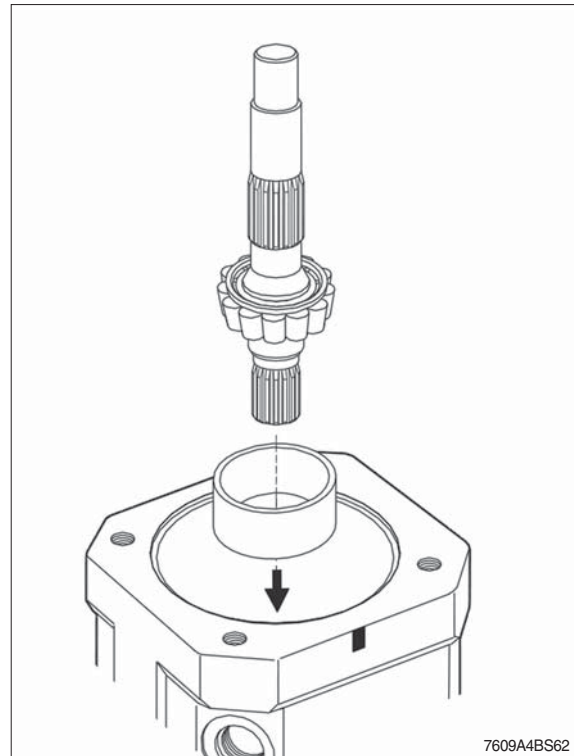

(5) Assemble swash plate.

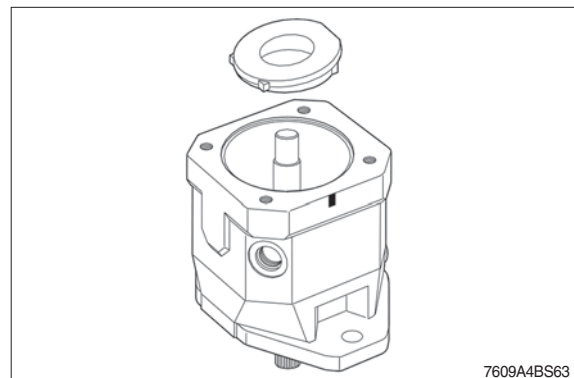

(6) Fit pressure pins using an assembly aid.

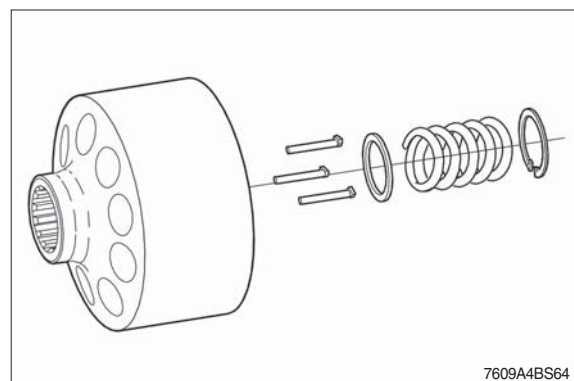

(7) Pre-tension the spring using a suitable device.

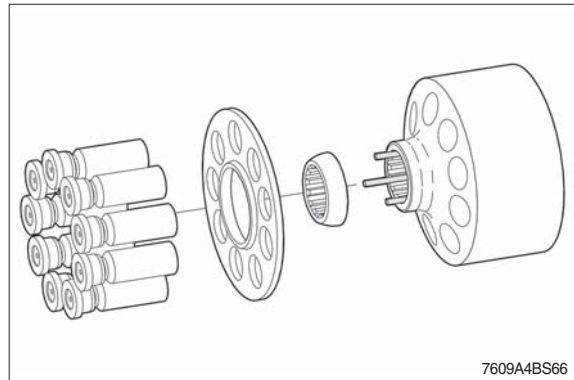
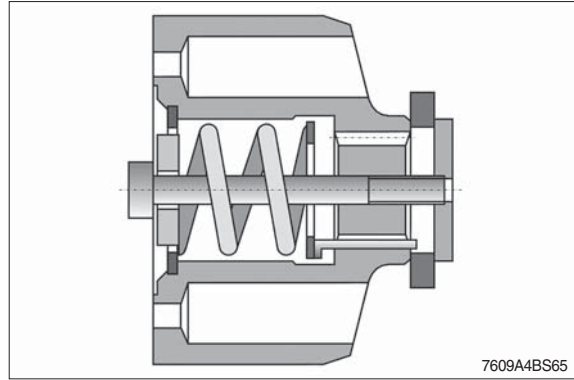

(8) Assemble piston with retaining plate.

※ Oil piston and slipper pad.

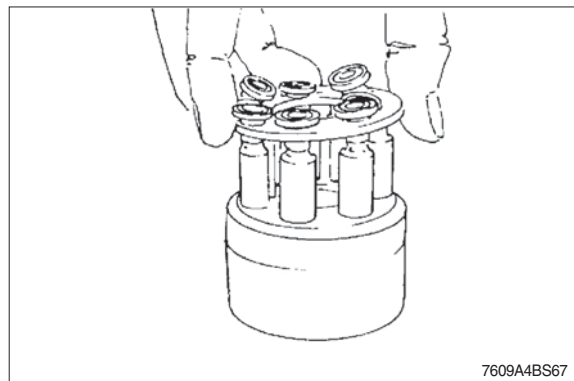

(9) Fit rotary group.

※ Assembly aid :

Hold the pistons by using an O-ring.

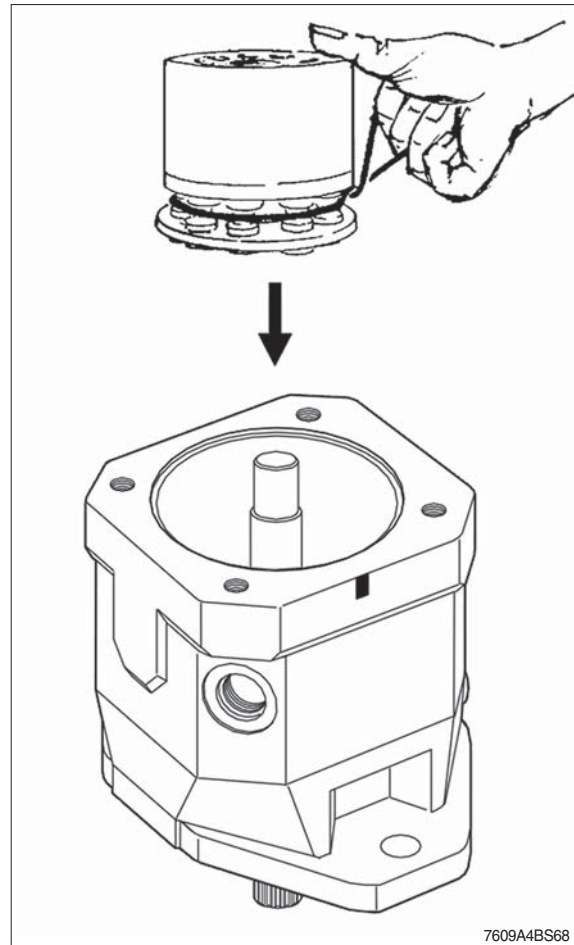

(10) Fit bearing (1) in port plate.

Fit cylindrical pin (2).

Fit O-ring (3).

Fit control plate (4).

※ Assembly :

Hold the components in place with grease.

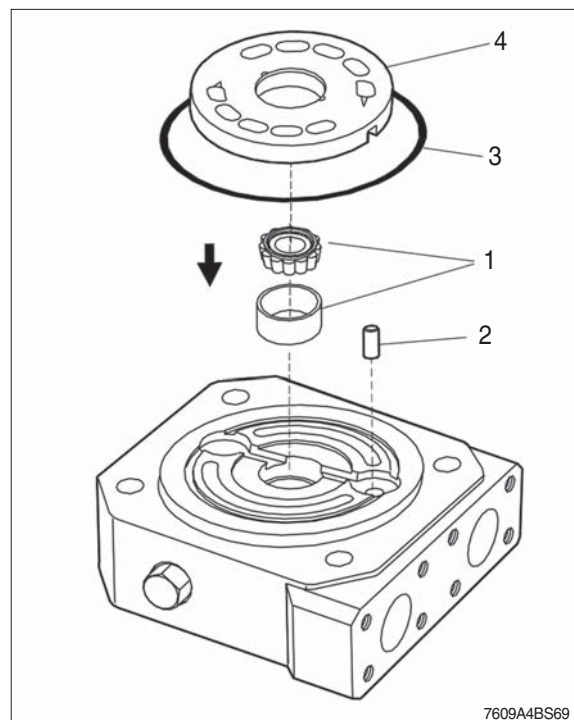

- (11) Fit control plate.
Assembly aid : Grease

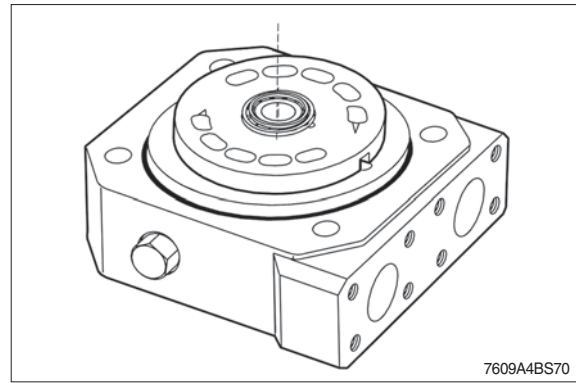

- (12) Fit the port plate and fix it with the bolts crosswise.

