

## SECTION 3 POWER TRAIN SYSTEM

Group 1	Structure and Function (fault code) .....	3-1
Group 2	Operational Checks and Troubleshooting .....	3-78
Group 3	Test and Adjustments .....	3-90
Group 4	Disassembly and Assembly .....	3-92

# SECTION 3 POWER TRAIN SYSTEM

## GROUP 1 STRUCTURE AND FUNCTION

### 1. POWER TRAIN COMPONENT OVERVIEW

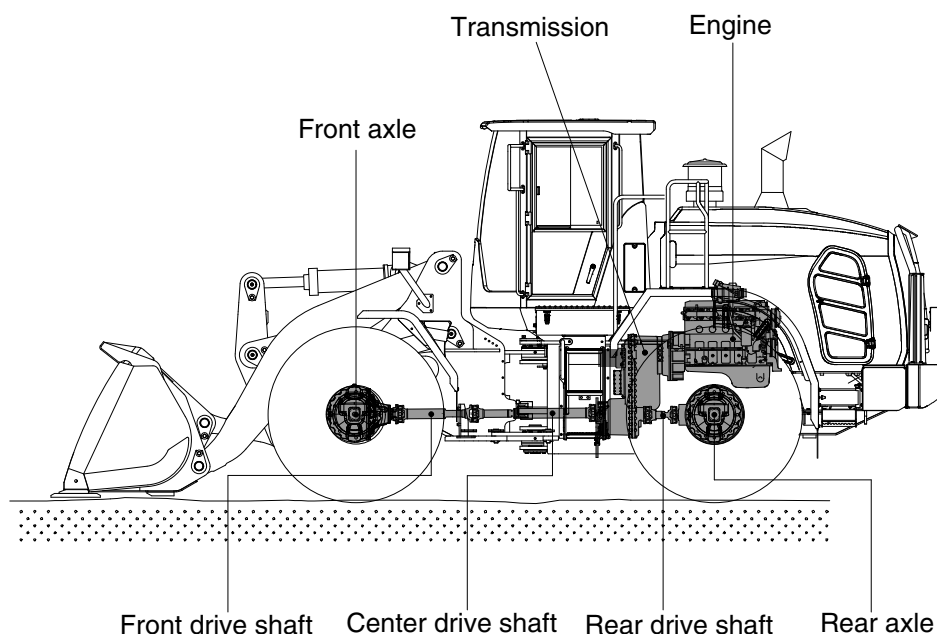

960A3PT01

The power train consists of the following components:

- Transmission
- Front, center and rear drive shafts
- Front and rear axles

Engine power is transmitted to the transmission through the torque converter.

The transmission is a hydraulically engaged four speed forward, three speed reverse countershaft type power shift transmission. A calliper-disc type parking brake is located on the transmission.

The transmission outputs through universal joints to three drive shaft assemblies. The front drive shaft is a telescoping shaft which drives the front axle. The front axle is mounted directly to the loader frame.

The front axle is equipped with limited slip differential as standard (option : Hyd lock differential).

The rear axle is equipped with limited slip differential as standard (option : conventional differential)

The rear axle is mounted on an oscillating pivot.

The power transmitted to front axle and rear axle is reduced by the pinion gear and ring gear of differential. It then passes from the differential to the sun gear shaft (axle shaft) of final drive.

The power of the sun gear is reduced by a planetary mechanism and is transmitted through the planetary hub to the wheel.

# HYDRAULIC CIRCUIT

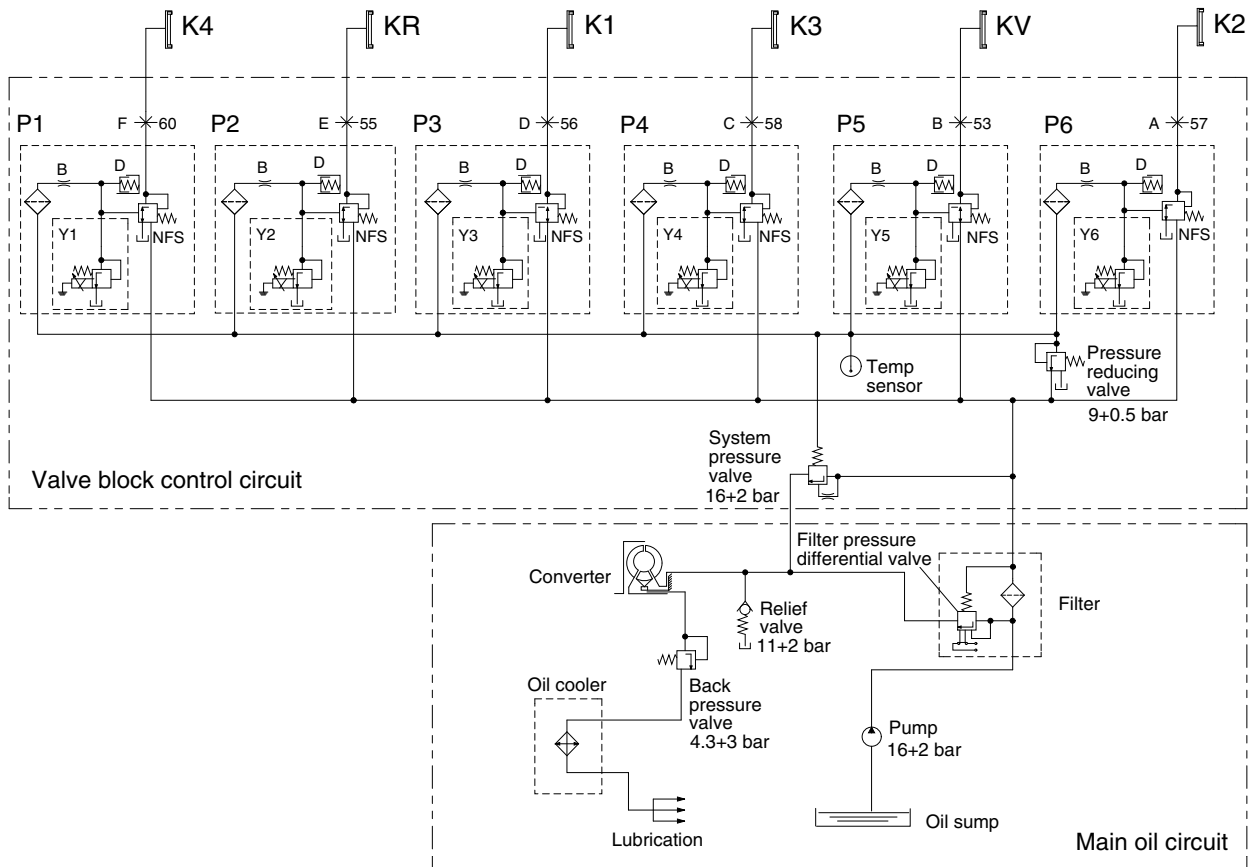

7607APT18-1

- |     |                              |       |                              |
|-----|------------------------------|-------|------------------------------|
| NFS | Follow-on slide              | P3    | Proportional valve clutch K1 |
| D   | Vibration damper             | P4    | Proportional valve clutch K3 |
| B   | Orifice                      | P5    | Proportional valve clutch KV |
| P1  | Proportional valve clutch K4 | P6    | Proportional valve clutch K2 |
| P2  | Proportional valve clutch KR | Y1~Y6 | Pressure regulator           |

Speed	Forward				Reverse			Neutral	Engaged clutch	Positions on the valve block	Current No. of the measuring points
	1	2	3	4	1	2	3				
Y1				X					K4	F	60
Y2					X	X	X		KR	E	55
Y3	X				X				K1	D	56
Y4			X	X			X		K3	C	58
Y5	X	X	X						KV	B	53
Y6		X				X			K2	A	57
Engaged clutch	K1,KV	KV,K2	K3,KV	K4,K3	KR,K1	KR,K2	KR, K3		-	-	-

X : Pressure regulator under voltage

## 2. TORQUE CONVERTER

### 1) FUNCTION

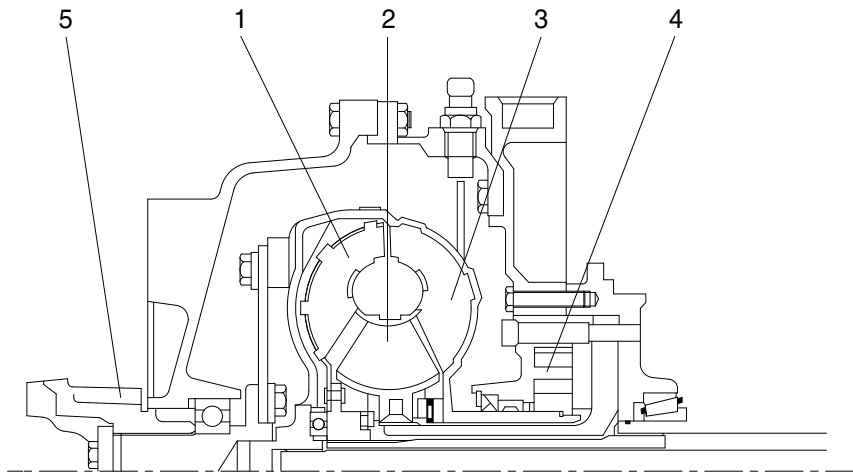

73033TM00

- |   |         |   |                   |   |              |
|---|---------|---|-------------------|---|--------------|
| 1 | Turbine | 3 | Pump              | 5 | Input flange |
| 2 | Stator  | 4 | Transmission pump |   |              |

The converter is working according to the Trilok-system, i.e. it assumes at high turbine speed the characteristics, and with it the favorable efficiency of a fluid clutch.

The converter is designed according to the engine power so that the most favorable operating conditions are obtained for each installation case.

The Torque converter is composed of 3 main components :  
Pump wheel - turbine wheel - stator (reaction member)

These 3 impeller wheels are arranged in such a ring-shape system that the fluid is streaming through the circuit components in the indicated order.

Pressure oil from the transmission pump is constantly streaming through the converter. In this way, the converter can fulfill its task to multiply the torque of the engine and at the same time, the heat created in the converter is dissipated via the escaping oil.

The oil which is streaming out of the pump wheel, enters the turbine wheel and is there inversed in the direction of flow.

According to the rate of reversion, the turbine wheel and with it also the output shaft is receiving a more or less high reaction torque. The stator (reaction member), following the turbine, has the task to reverse the oil streaming out of the turbine once more and to deliver it under the suitable discharge direction to the pump wheel.

Due to the reversion, the stator receiving a reaction torque.

The relation turbine torque/pump torque is called torque multiplication. This is the higher, the greater the speed difference of pump wheel and turbine wheel will be.

Therefore, the maximum torque multiplication is created at stationary turbine wheel.

With increasing output speed, the torque multiplication is decreasing. The adaption of the output speed to a certain required output torque will be infinitely variable and automatically achieved by the torque converter.



When the turbine speed is reaching about 80% of the pump speed, the torque multiplication becomes 1.0 i.e. the turbine torque becomes equal to that of the pump torque.  
 From this point on, the converter is working similar to a fluid clutch.

A stator freewheel serves to improve the efficiency in the upper driving range, in the torque multiplication range it is backing-up the torque upon the housing, and is released in the clutch range. In this way, the stator can rotate freely.

Function of a hydrodynamic torque converter (schematic view)

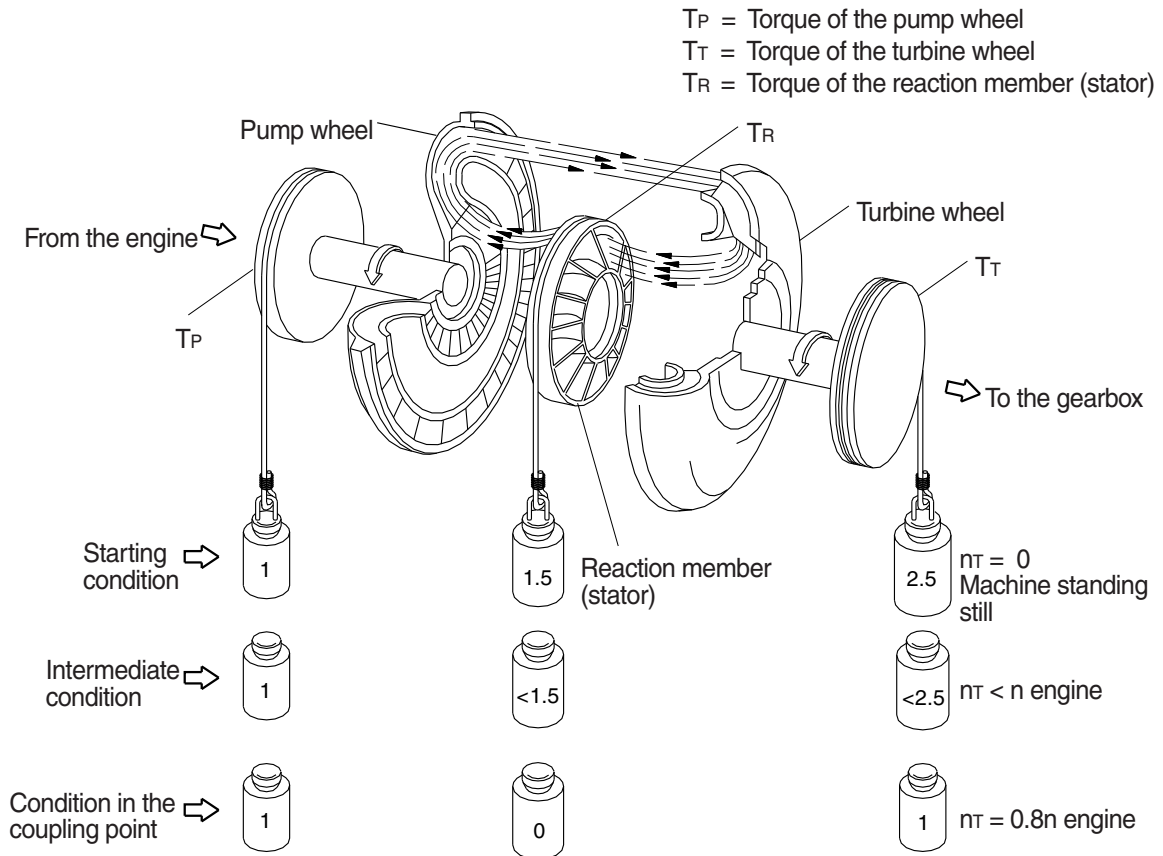

7577APT100

### 3. TRANSMISSION

#### 1) LAYOUT

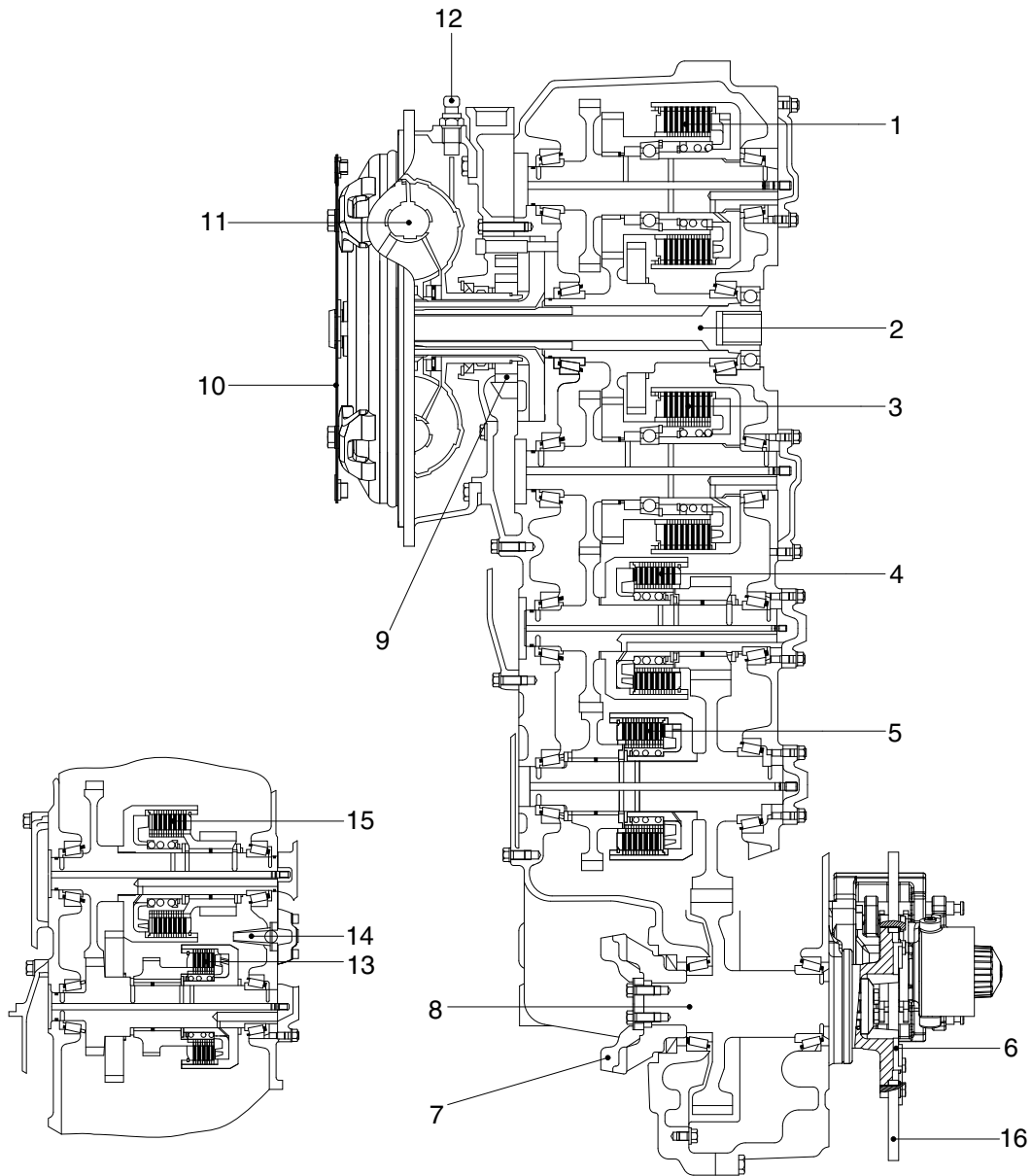

7577APT03

- |   |                                 |    |                              |    |  |
|---|---------------------------------|----|------------------------------|----|--|
| 1 | Reverse clutch (KR)             | 7  | Converter side output flange | 12 | Inductive transmitter for engine speed |
| 2 | Engine-dependent power take-off | 8  | Output shaft                 | 13 | 4th clutch (K4)                        |
| 3 | Forward clutch (KV)             | 9  | Transmission pump            | 14 | Converter relief valve                 |
| 4 | 2nd clutch (K2)                 | 10 | Connection to engine         | 15 | 1st clutch (K1)                        |
| 5 | 3rd clutch (K3)                 | 11 | Converter                    | 16 | Parking brake                          |
| 6 | Rear output flange              |    |                              |    |  |

## 2) INSTALLATION VIEW

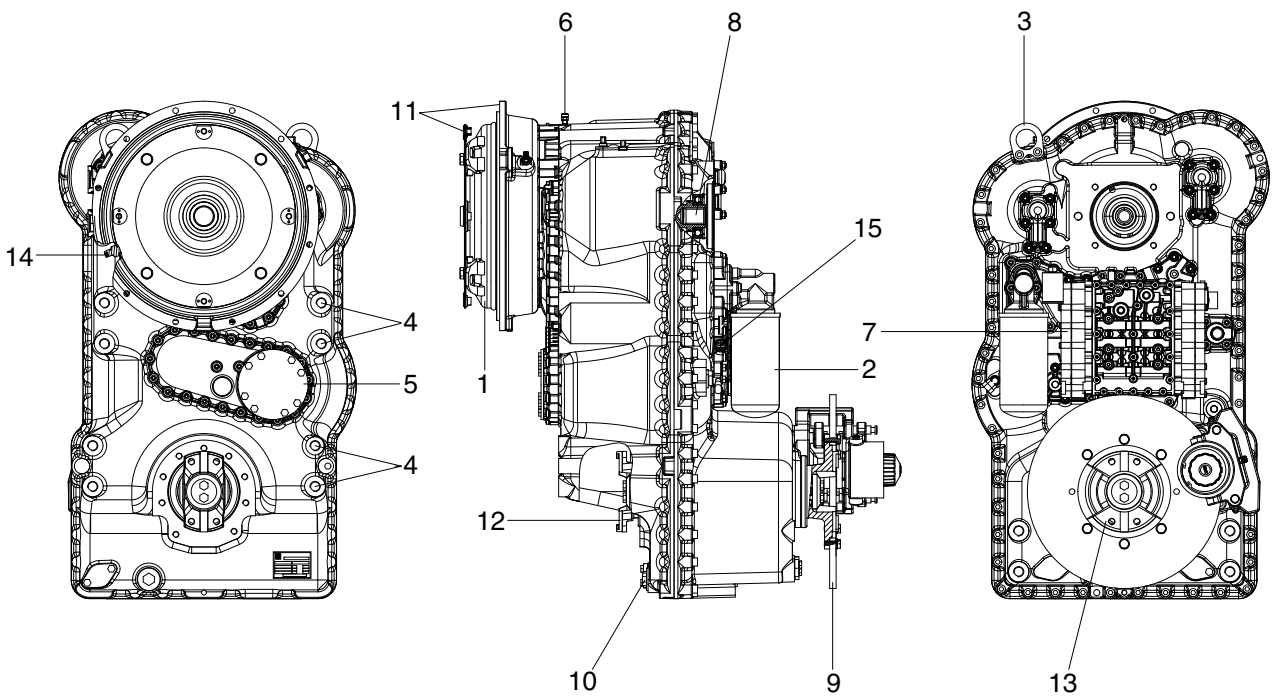

955SA3PT02

- |   |  |    |   |
|---|--|----|---|
| 1 | Converter                                    | 9  | Parking brake   |
| 2 | Full flow filter                             | 10 | Oil drain plug  |
| 3 | Transportation eye                           | 11 | Connection to engine                                    |
| 4 | Gearbox mounting pads                        | 12 | Output flange-Converter side                            |
| 5 | Mounting possibility emergency steering pump | 13 | Output flange-Rear side                                 |
| 6 | Breather                                     | 14 | Temperature switch for oil temperature behind converter |
| 7 | Electrical hydraulic transmission control    | 15 | Difference pressure switch for pressure filter          |
| 8 | Power take-off; Coaxial; Engine dependent    |    |   |

### 3) OPERATION OF TRANSMISSION

#### (1) Forward

##### ① Forward 1st

In 1st forward, forward clutch (KV) and 1st clutch (K1) are engaged.

Forward clutch and 1st clutch are actuated by the hydraulic pressure applied to the clutch piston.

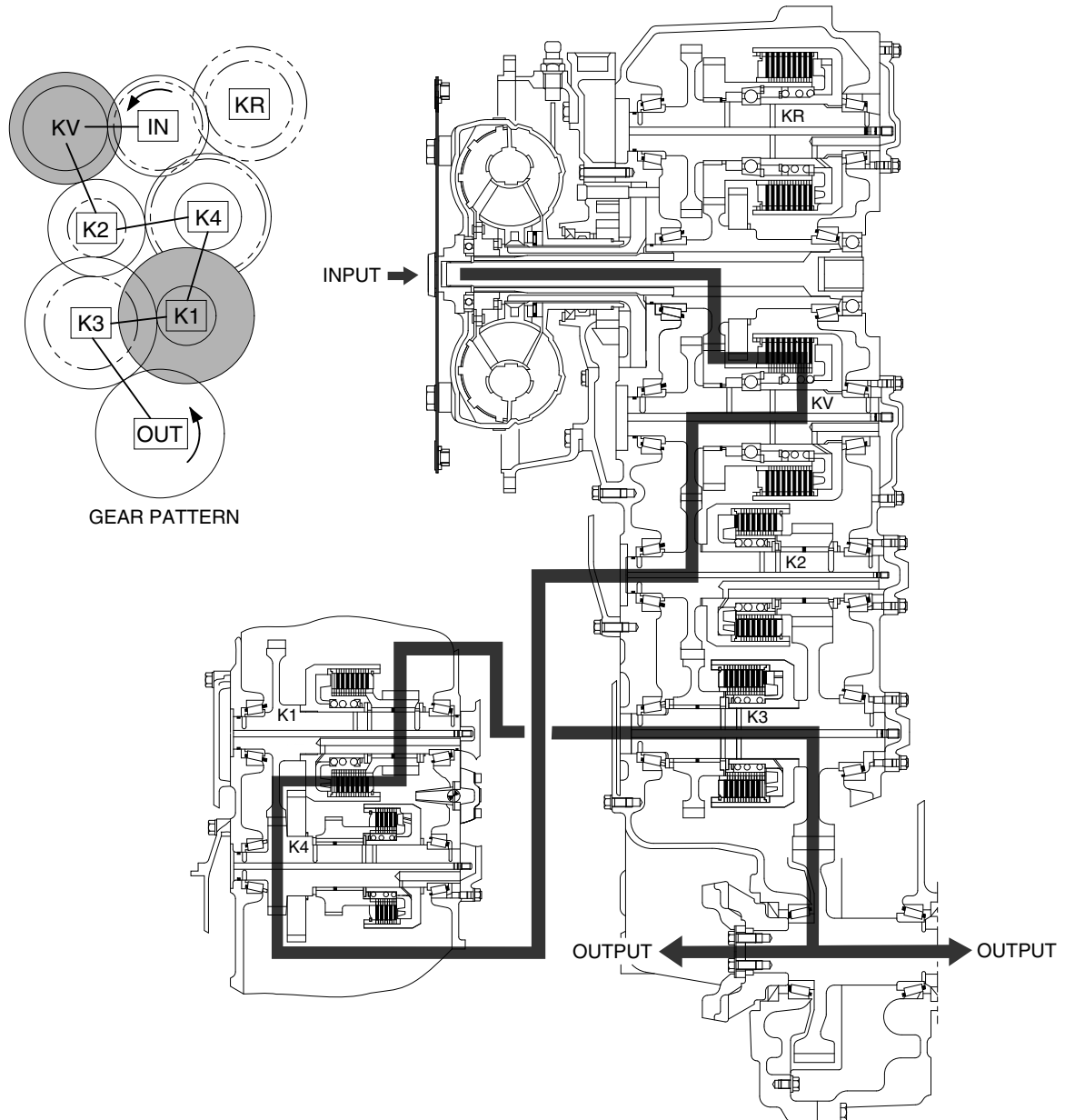

7577APT04 F1

② Forward 2nd

In 2nd forward, forward clutch (KV) and 2nd clutch (K2) are engaged.

Forward clutch and 2nd clutch are actuated by the hydraulic pressure applied to the clutch piston.

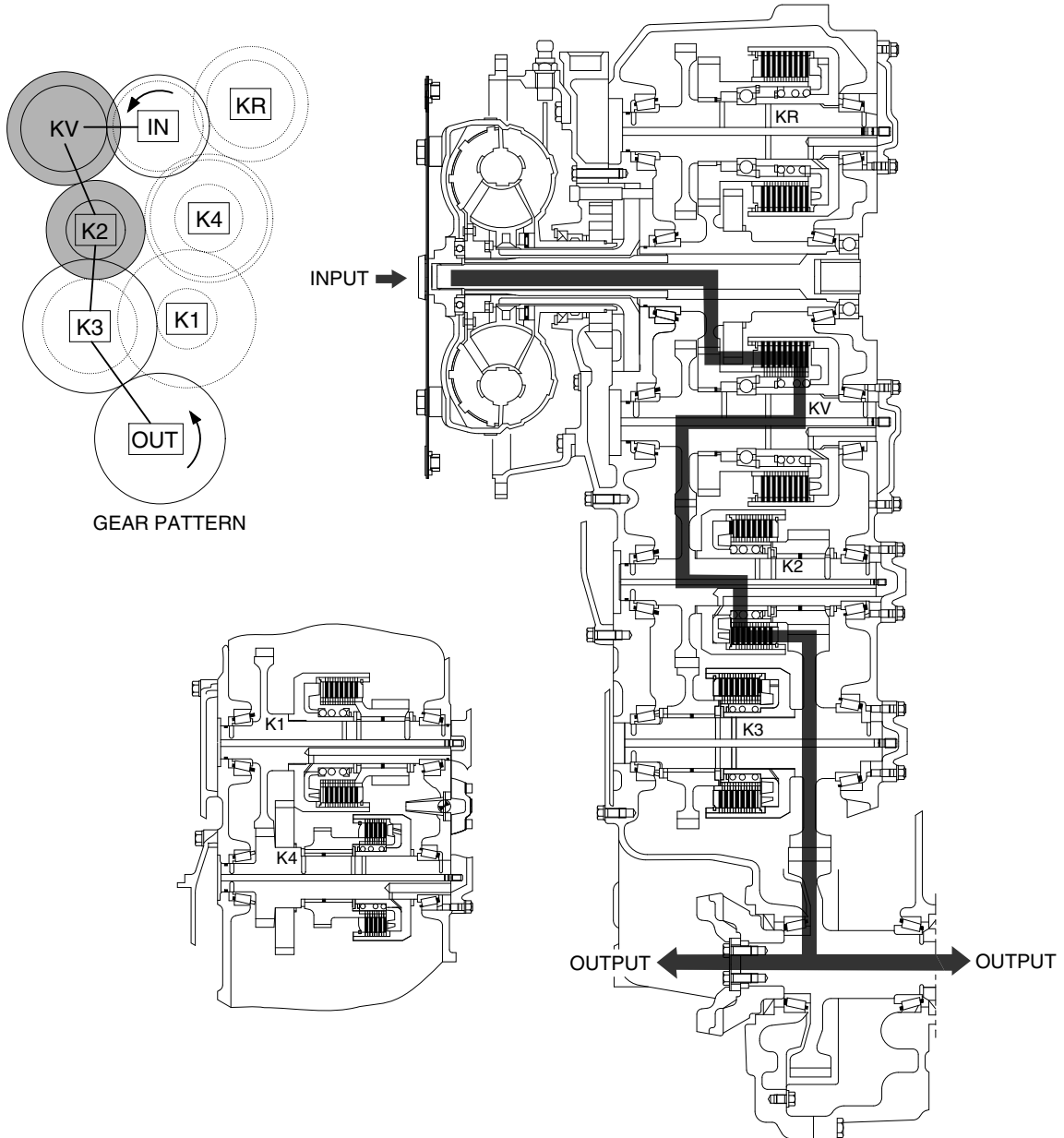

### ③ Forward 3rd

In 3rd forward, forward clutch (KV) and 3rd clutch (K3) are engaged.

Forward clutch and 3rd clutch are actuated by the hydraulic pressure applied to the clutch piston.

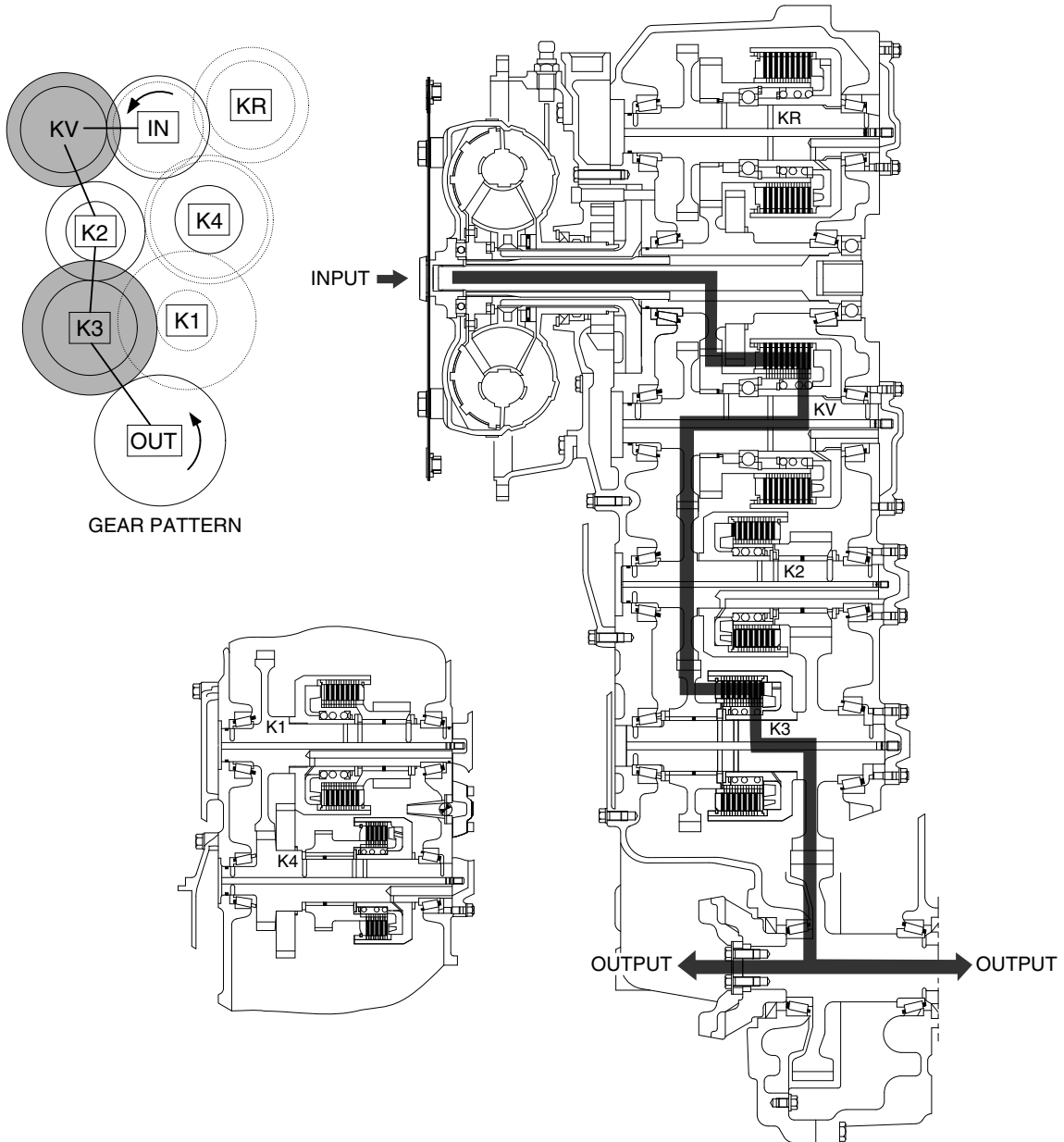

7577APT06 F3

#### ④ Forward 4th

In 4th forward, 4th clutch (K4) and 3rd clutch (K3) are engaged.

4th clutch and 3rd clutch are actuated by the hydraulic pressure applied to the clutch piston.

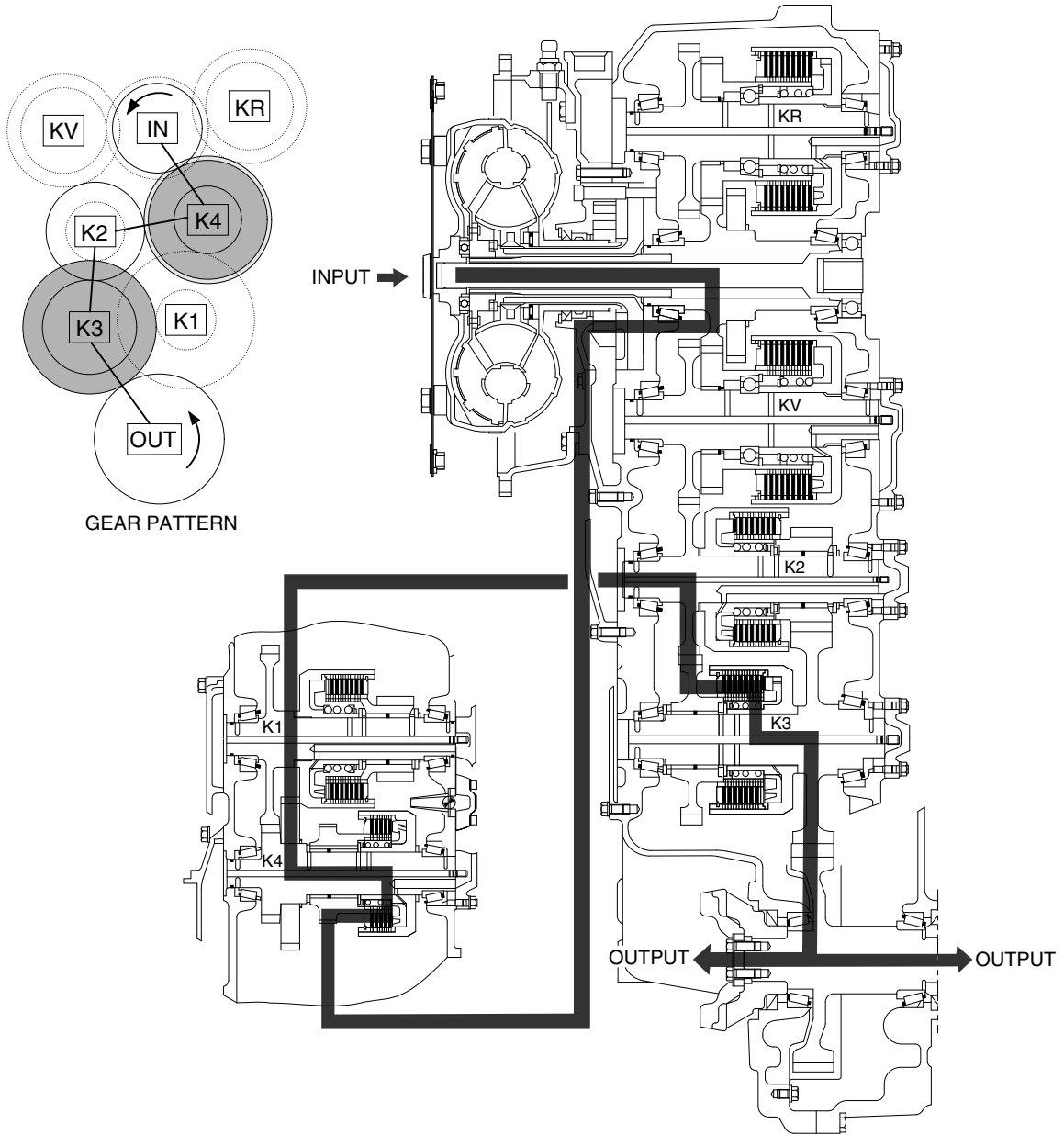

7577APT07 F4

## (2) Reverse

### ① Reverse 1st

In 1st reverse, reverse clutch (KR) and 1st clutch (K1) are engaged.

Reverse clutch and 1st clutch are actuated by the hydraulic pressure applied to the clutch piston.

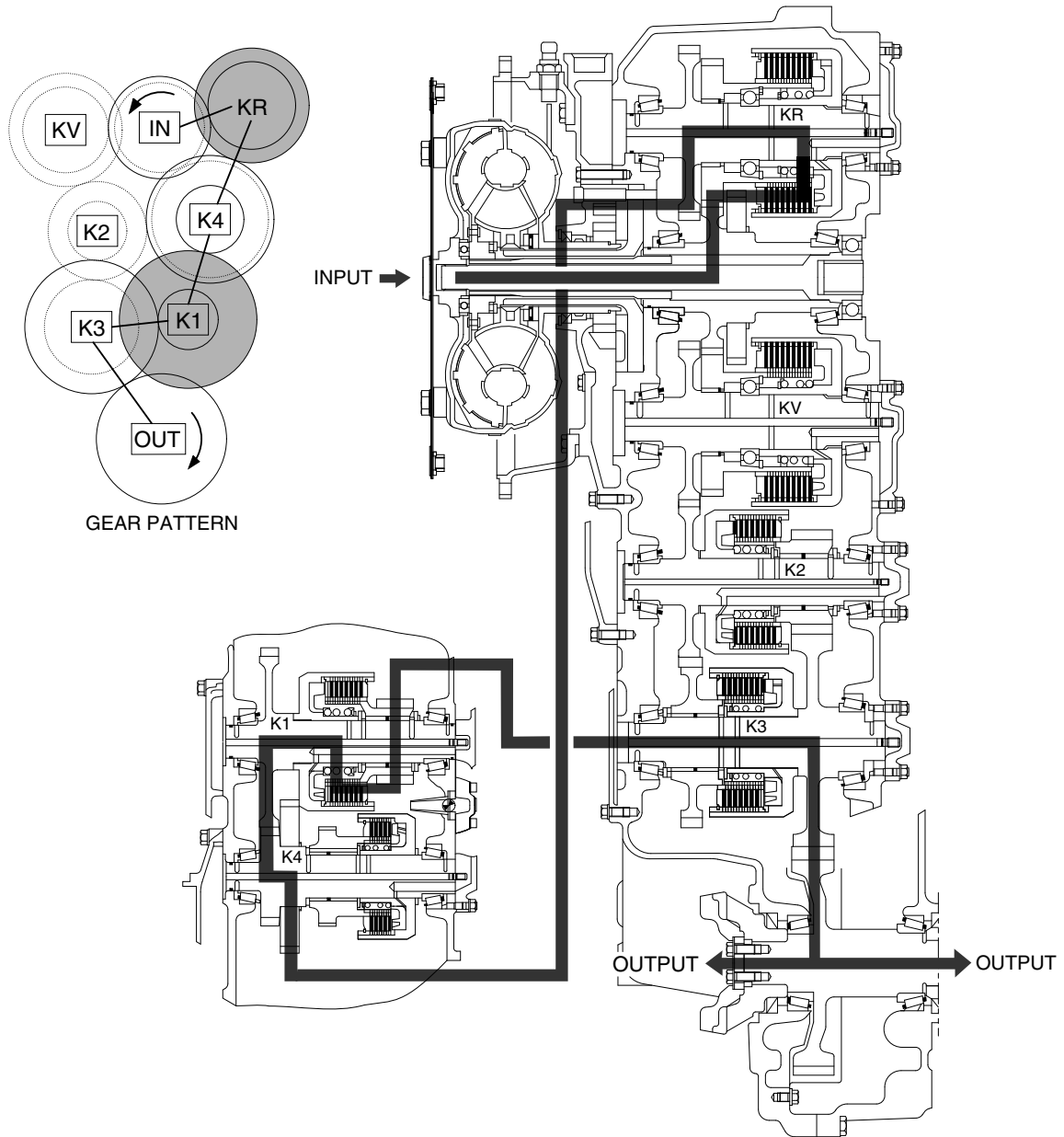

7577APT08 R1



## ② Reverse 2nd

In 2nd reverse, reverse clutch (KR) and 2nd clutch (K2) are engaged.

Reverse clutch and 2nd clutch are actuated by the hydraulic pressure applied to the clutch piston.

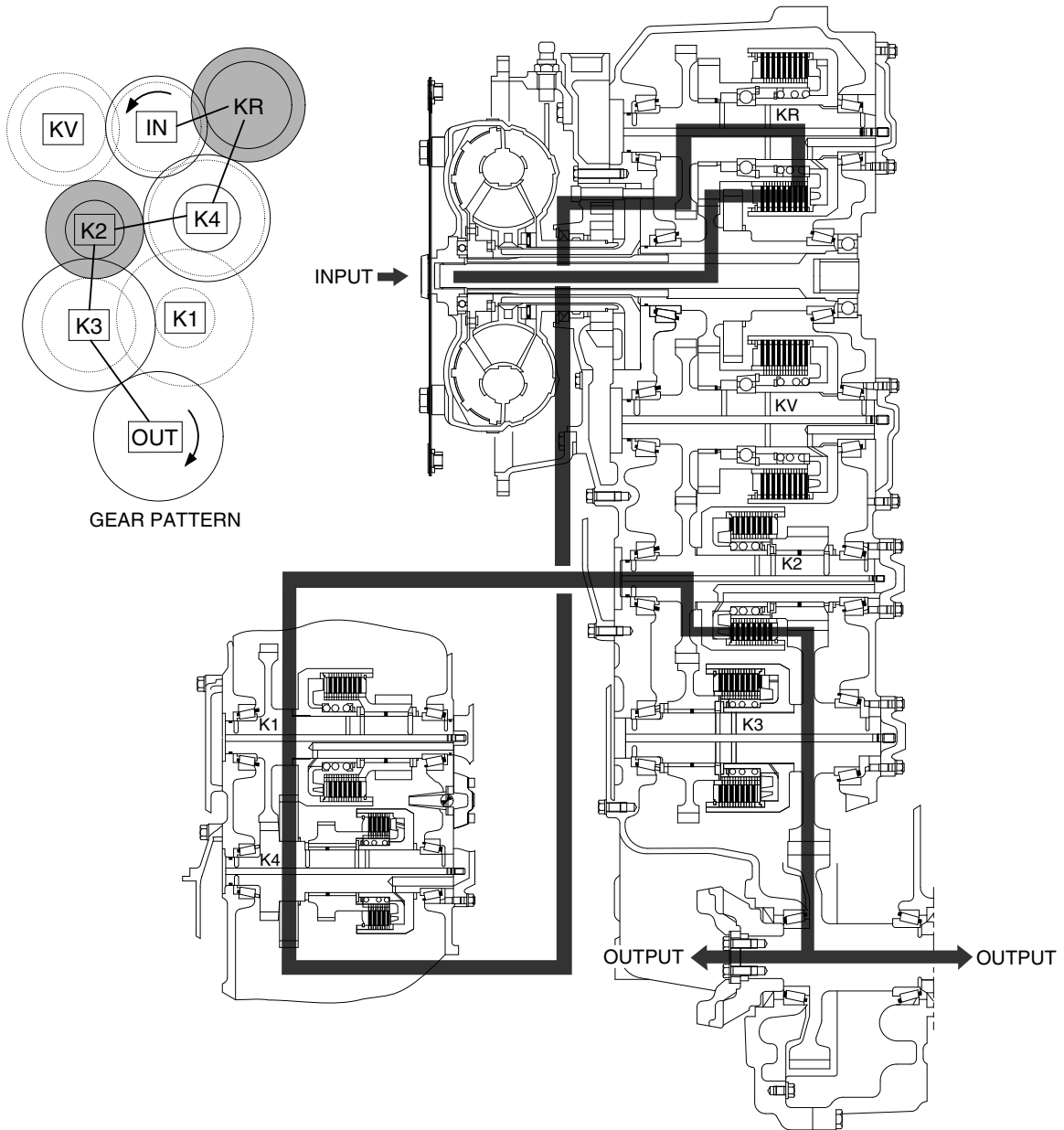

7577APT09 R2

### ③ Reverse 3rd

In 3rd reverse, reverse clutch (KR) and 3rd clutch (K3) are engaged.

Reverse clutch and 3rd clutch are actuated by the hydraulic pressure applied to the clutch piston.

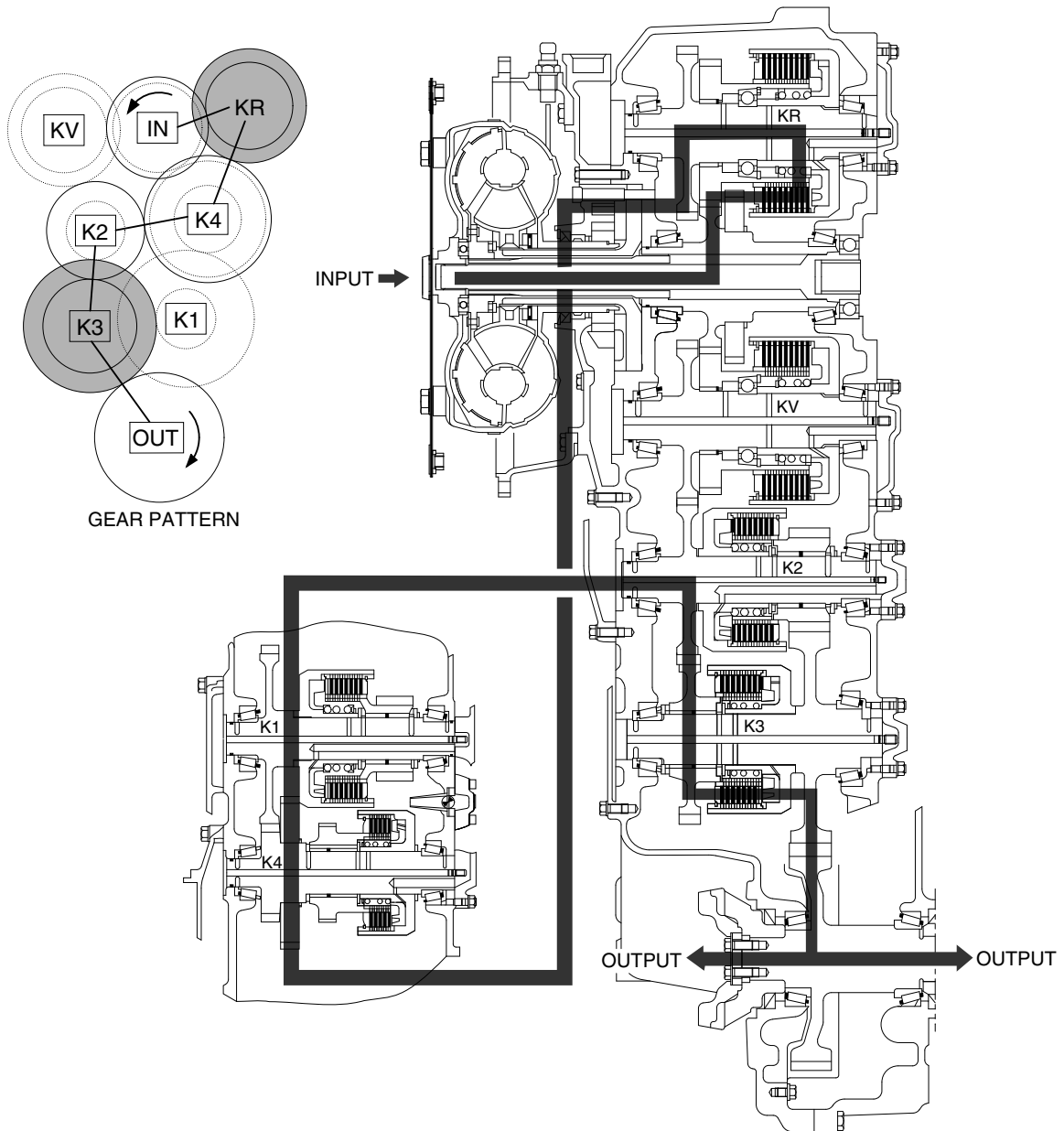

7577APT10 R3

#### 4) ELECTRO-HYDRAULIC SHIFT CONTROL WITH PROPORTIONAL VALVE

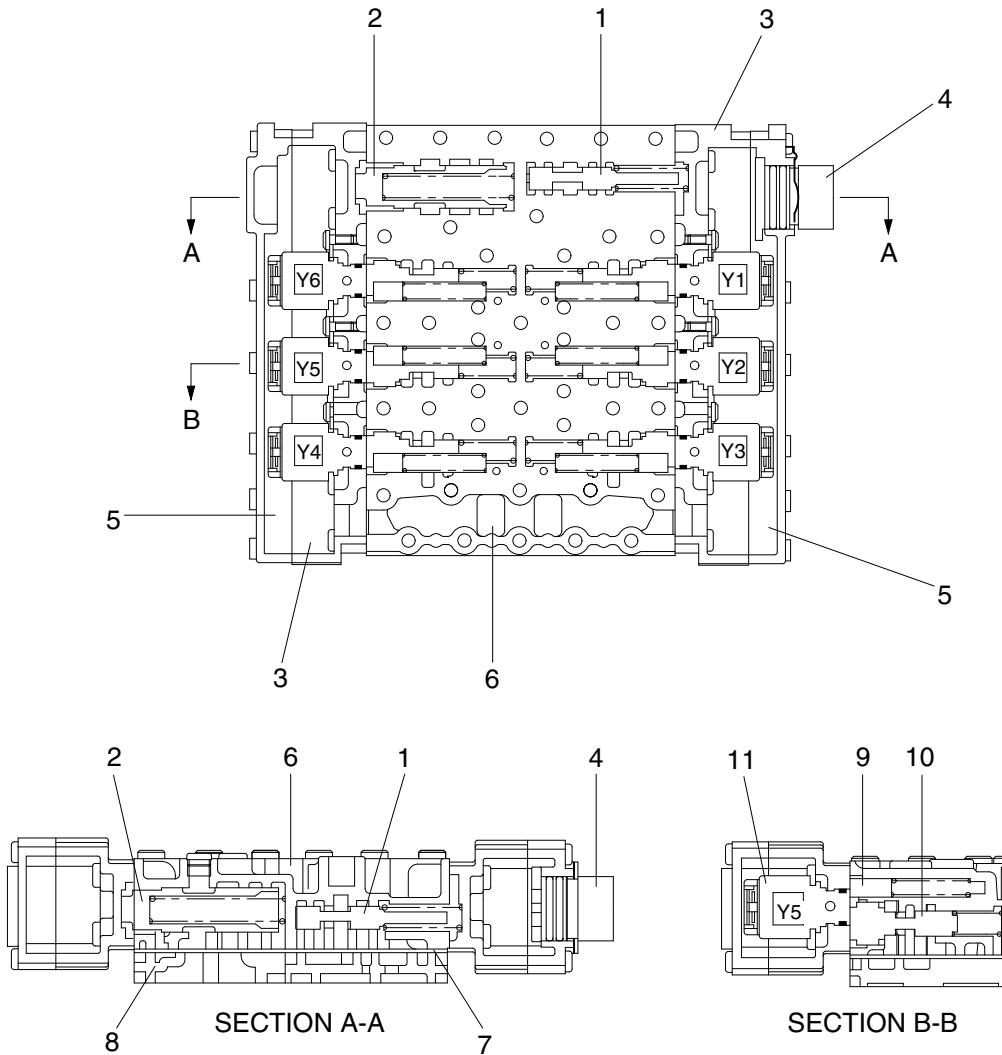

73033CV01

- |   |                                     |    |                    |
|---|-------------------------------------|----|--------------------|
| 1 | Pressure reducing valve (9+0.5 bar) | 7  | Intermediate sheet |
| 2 | System pressure valve (16+2 bar)    | 8  | Duct plate         |
| 3 | Housing                             | 9  | Oscillation damper |
| 4 | Cable harness                       | 10 | Follow-on slide    |
| 5 | Cover                               | 11 | Pressure regulator |
| 6 | Valve block                         |    |                    |

Transmission control, see schedule of hydraulic circuit, electro-hydraulic control unit and measuring points at page 3-2, 3-14 and 3-90.

The six clutches of the transmission are selected via the 6 proportional valves P1 to P6. The proportional valve (pressure regulator unit) is composed of pressure regulator (e.g. Y1), follow-on slide and vibration damper.

The control pressure of 9 bar for the actuation of the follow-on slides is created by the pressure reducing valve. The pressure oil (16+2 bar) is directed via the follow-on slide to the respective clutch.

Due to the direct proportional selection with separated pressure modulation for each clutch, the pressures to the clutches, which are engaged in the gear change, will be controlled. In this way, a hydraulic intersection of the clutches to be engaged and disengaged becomes possible.

This is creating spontaneous shiftings without traction force interruption.

At the shifting, the following criteria are considered:

- Speed of engine, turbine, central gear train and output.
- Transmission temperature.
- Shifting mode (Up-, down-, reverse shifting and speed engagement out of neutral).
- Load condition (full and part load, traction, overrun inclusive consideration of load cycles during the shifting).

The main pressure valve is limiting the maximum control pressure to 16+2 bar and releases the main stream to the converter and lubricating circuit.

In the inlet to the converter, a converter safety valve is installed which protects the converter from high internal pressures (opening pressure 11+2 bar).

Within the converter, the oil serves to transmit the power according to the well-known hydrodynamic principle (see torque converter, page 3-3).

To avoid cavitation, the converter must be always completely filled with oil.

This is achieved by a converter back pressure back-up valve, rear-mounted to the converter, with an opening pressure of at least 4.3bar.

The oil, escaping out of the converter, is directed to a oil cooler.

The oil is directed from the oil cooler to the transmission and from there to the lubricating oil circuit, so that all lubricating points are supplied with cooled oil.

In the electro-hydraulic control unit are 6 pressure regulators installed.

## 5) GEAR SELECTOR (DW-3)

The gear selector is designed for the mounting on the left side of the steering column. The positions (speeds) 1 to 4 are selected by a rotary motion, the driving direction Forward (F)-Neutral (N)-Reverse (R) by tilting the gear selector lever.

The gear selector is also available with integrated kickdown push button.

For the protection from unintended start off, a neutral interlock is installed.

Position N - Gear selector lever blocked in this position.

Position D - Driving.

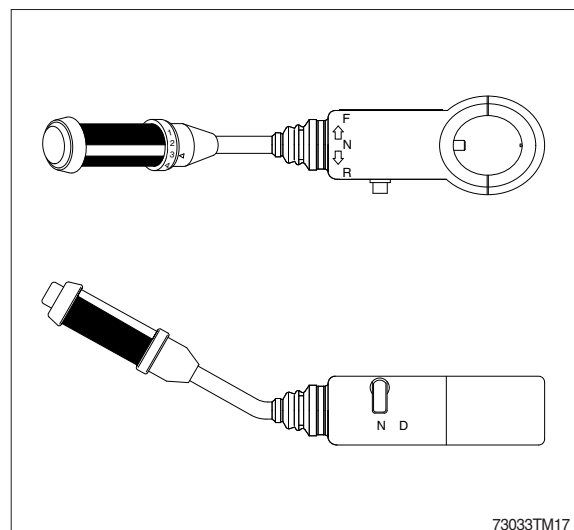

## 6) ELECTRIC CONTROL UNIT

### (1) Complete system

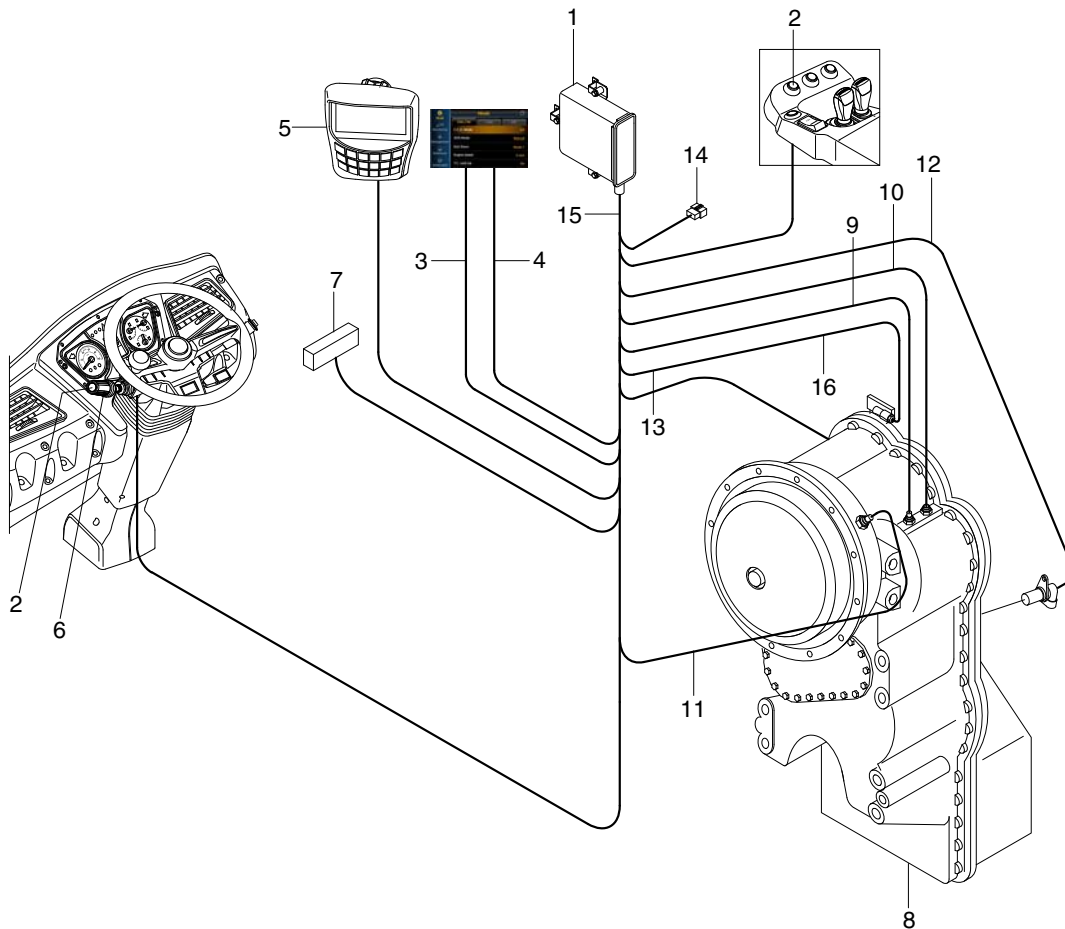

760F3PT37

- 1 Transmission control unit (EST-37A)
- 2 Kickdown switch
- 3 Clutch cut off mode
- 4 Transmission shift mode
- 5 Monitor
- 6 Gear selector (DW-3) with integrated kickdown switch
- 7 Power supply connection
- 8 Transmission
- 9 Cable to inductive transmitter - speed central gear train
- 10 Cable to inductive transmitter - speed turbine
- 11 Cable to inductive transmitter - speed engine
- 12 Cable to speed sensor output and speedometer
- 13 Cable to plug connection on the electro - hydraulic control unit
- 14 CAN-Connection
- 15 Wiring
- 16 Cable to lock-up clutch valve (not used)

### (2) Description of the basic functions

The powershift transmissions is equipped is electronic transmission control unit (EST-37A), developed for it.

The system is processing the desire of the driver according to the following criteria.

- Gear determination depending on controller position, driving speed and load condition.

- Protection from operating errors as far as necessary, is possible via electronic protection (programming).
- Protection from over-speeds (On the basis of engine and turbine speed).
- Automatic reversing (Driving speed-dependent).
- Pressure cut-off possible (disconnecting of the drive train for maximum power on the power take-off).
- Change-over possibility for Auto-/Manual mode.
- Kick down functions possible.

### **(3) Driving and shifting**

#### - Neutral position :

Neutral position will be selected via the controller.

After the ignition is switched on, the electronics remains in the waiting state. By the position NEUTRAL of the controller, resp. by pressing the pushbutton NEUTRAL, the EST-37A becomes ready for operation.

Now, a gear can be engaged.

#### - Starting :

The starting of the engine has always to be carried out in the NEUTRAL POSITION of the controller.

For safety reasons it is to recommend to brake the machine securely in position with the parking brake prior to start the engine.

After the starting of the engine and the preselection of the driving direction and the gear, the machine can be set in motion by acceleration.

At the start off, the converter takes over the function of a master clutch.

On a level road it is possible to start off also in higher gears.

#### - Upshifting under load

Upshifting under load will be then realized if the machine can still accelerate by it.

#### - Downshifting under load

Downshifting under load will be realized if more traction force is needed.

#### - Upshifting in overrunning condition

In the overrunning mode, the upshifting will be suppressed by accelerator pedal idling position, if the speed of the machine on a downgrade should not be further increased.

#### - Downshifting in overrunning condition

Downshiftings in overrunning mode will be then carried out if the machine should be retarded.

If the machine will be stopped and is standing with running engine and engaged transmission, the engine cannot be stalled. On a level and horizontal roadway it is possible that the machine begins to crawl, because the engine is creating at idling speed a slight drag torque via the converter.

It is convenient to brake the machine at every stop securely in position with the parking brake.

At longer stops, the controller has to be shifted to the NEUTRAL POSITION.

At the start off, the parking brake has to be released. We know from experience that at a converter transmission it might not immediately be noted to have forgotten this quite normal operating step because a converter, due to its high ratio, can easily overcome the braking torque of the parking brake.

Temperature increases in the converter oil as well as overheated brakes will be the consequences to be find out later.

Neutral position of the selector switch at higher machine speeds (above stepping speed) is not admissible.

Either a suitable gear is to be shifted immediately, or the machine must be stopped at once.

#### **(4) Independent calibration of the shifting elements (AEB)**

The AEB has the task to compensate tolerances (plate clearance and pressure level) which are influencing the filling procedure of the clutches. For each clutch, the correct filling parameters are determined in one test cycle for :

- Period of the quick-filling time
- Level of the filling compensating pressure

The filling parameters are stored, together with the AEB-program and the driving program in the transmission electronics. Because the electronics will be separately supplied, the AEB-cycle must be started only after the installation of both components in the machine, thus ensuring the correct mating (Transmission and electronics).

※ It is imperative, to respect the following test conditions :

- Shifting position neutral
- Engine in idling speed
- Parking brake actuated
- Transmission in operating temperature

※ After a replacement of the transmission, the electrohydraulic control or the TCU in the machine, the AEB-cycle must be as well carried out again.

The AEB-cycle continues for about 3 to 4 minutes. The determined filling parameters are stored in the EEPROM of the electronics. In this way, the error message F6 shown on the display will be cancelled also at non-performed AEB.

#### **(5) Pressure cut-off**

In order to provide the full engine power for the hydraulic system, the control can be enlarged for the function of a pressure cut-off in the 1st and 2nd speed. In this way, the pressure in the powershift clutches will be cut-off, and the torque transmission in the drive train will be eliminated by it. This function will be released at the actuation of a switch, arranged on the brake pedal.

For a soft restart, the pressure will be build-up via a freely programmable characteristic line.

#### 4. FAULT CODE

##### 1-1) MACHINE FAULT CODE

DTC		Diagnostic Criteria	Application		
HCESPN	FMI		G	C	S
101	3	10 seconds continuous, Hydraulic Oil Temp. Measurement Voltage > 3.95 V	●		
	4	10 seconds continuous, Hydraulic Oil Temp. Measurement Voltage < 0.3 V	●		
	(Results / Symptoms) 1. Monitor – Hydraulic Oil temperature display failure 2. Control Function – No warming up operation, No fuel warmer function operation, High hydraulic oil temperature warning failure  (Checking list) 1. CN-58B (#23) – CD-01 (#2) Checking Open/Short 2. CN-58B (#25) – CD-01 (#1) Checking Open/Short				
202	0	10 seconds continuous, Steering main pump pressure Measurement Voltage > 5.3 V	●		
	4	10 seconds continuous, Steering main pump pressure Measurement Voltage < 0.3 V	●		
	(Results / Symptoms) 1. Monitor – Steering main pump press. Display failure 2. Control Function – No automatic Emergency steering operation, ECO gauge display failure 3. RMS – Working hours accumulation failure (Checking list) 1. CN-58B (#35) – CD-39 (B) Checking Open/Short 2. CN-58A (#11) – CD-39 (A) Checking Open/Short 3. CN-58B (#25) – CD-39 (C) Checking Open/Short				
204	0	10 seconds continuous, Boom cylinder 'head' pressure Measurement Voltage > 5.3 V	●		
	4	10 seconds continuous, Boom cylinder 'head' pressure Measurement Voltage < 0.3 V	●		
	(Results / Symptoms) 1. Monitor – Boom cylinder 'head' press. display failure 2. Control Function – No Boom pressure calibration function operation, workload measurement sys. operation failure  (Checking list) 1. CN-58B (#29) – CD-80 (B) Checking Open/Short 2. CN-58A (#11) – CD-80 (A) Checking Open/Short 3. CN-58B (#25) – CD-80 (C) Checking Open/Short				

G : General    C : Cummins Engine application equipment    S : Scania Engine application equipment



DTC		Diagnostic Criteria	Application		
HCESPN	FMI		G	C	S
205	0	10 seconds continuous, Boom cylinder 'rod' pressure Measurement Voltage > 5.3V	●		
	4	10 seconds continuous, Boom cylinder 'rod' pressure Measurement Voltage < 0.3V	●		
	(Results / Symptoms) 1. Monitor – Boom cylinder 'rod' press. display failure 2. Control Function – No Boom pressure calibration function operation, workload measurement sys. operation failure (Checking list) 1. CN-58B(#36) – CD-81(B) Checking Open/Short 2. CN-58A(#11) – CD-81(A) Checking Open/Short 3. CN-58B(#25) – CD-81(C) Checking Open/Short				
301	3	10 seconds continuous, Fuel level Measurement Voltage > 3.8V	●		
	4	10 seconds continuous, Fuel level Measurement Voltage < 0.3V	●		
	(Results / Symptoms) 1. Monitor – Fuel level display failure 2. Control Function – Fuel level low warning operation failure (Checking list) 1. CN-58B (#22) – CD-02 (#2) Checking Open/Short 2. CN-58B (#25) – CD-02 (#1) Checking Open/Short				
318	8	(In the startup conditions) 30 seconds continuous, Fan speed < 10 rpm in the Remote cooling fan EPPR current reference value is in X Ma(differ by model)	●		
	(Results / Symptoms) 1. Monitor – Cooling Fan revolutions display failure (Checking list) 1. CN-58A (#15) – CD-73 (#1) Checking Open/Short 2. CN-58A (#18) – CD-73 (#2) Checking Open/Short				
339	3	10 seconds continuous, Accel pedal position 1 voltage Measurement Voltage > 5.0 V			●
	4	10 seconds continuous, Accel pedal position 1 voltage Measurement Voltage < 0.2 V			●
	(Results / Symptoms) 1. Monitor – Accel pedal position 1 voltage display failure 2. Control Function – Engine rpm control failure (Checking list) 1. CN-58B(#39) – CN-162(#2) Checking Open/Short 2. CN-58A(#6) – CN-162(#3) Checking Open/Short 3. CN-58A(#8) – CN-162(#1) Checking Open/Short				

G : General    C : Cummins Engine application equipment    S : Scania Engine application equipment

DTC		Diagnostic Criteria	Application		
HCESPN	FMI		G	C	S
343	3	10 seconds continuous, Accel pedal position 2 voltage Measurement Voltage > 5.0 V			●
	4	10 seconds continuous, Accel pedal position 2 voltage Measurement Voltage < 0.2 V			●
	(Results / Symptoms) 1. Monitor – Accel pedal position 2 voltage display failure 2. Control Function – Engine rpm control failure (Checking list) 1. CN-58B (#40) – CN-162 (#5) Checking Open/Short 2. CN-58A (#7) – CN-162 (#6) Checking Open/Short 3. CN-58A (#9) – CN-162 (#4) Checking Open/Short				
503	0	10 seconds continuous, Brake oil pressure Measurement Voltage > 5.3V	●		
	4	10 seconds continuous, Brake oil pressure Measurement Voltage < 0.3V	●		
	(Results / Symptoms) 1. Monitor – Brake oil press. display failure 2. Control Function – Brake oil pressure low warning display failure (Checking list) 1. CN-58B (#27) – CD-03 (B) Checking Open/Short 2. CN-58A (#11) – CD-03 (A) Checking Open/Short 3. CN-58B (#25) – CD-03 (C) Checking Open/Short				
507	0	10 seconds continuous, Parking oil pressure Measurement Voltage > 5.3V	●		
	4	10 seconds continuous, Parking oil pressure Measurement Voltage < 0.3V	●		
	(Results / Symptoms) 1. Monitor – Parking oil Press. display failure 2. Control Function – No judgment Parking status (Checking list) 1. CN-58B (#34) – CD-26 (B) Checking Open/Short 2. CN-58A (#11) – CD-26 (A) Checking Open/Short 3. CN-58B (#25) – CD-26 (C) Checking Open/Short				
557	0	10 seconds continuous, Brake oil charging priority pressure Measurement Voltage > 5.3V	●		
	4	10 seconds continuous, Brake oil charging priority pressure Measurement Voltage < 0.3V	●		
	(Results / Symptoms) 1. Monitor – Brake oil charging priority press. display failure 2. Control Function – Cooling fan revolutions control failure, Brake oil(Accumulator) charging failure (Checking list) 1. CN-58B (#38) – CD-31 (B) Checking Open/Short 2. CN-58A (#11) – CD-31 (A) Checking Open/Short 3. CN-58B (#25) – CD-31 (C) Checking Open/Short				

G : General    C : Cummins Engine application equipment    S : Scania Engine application equipment

DTC		Diagnostic Criteria	Application		
HCESPN	FMI		G	C	S
705	0	10 seconds continuous, Battery input Voltage > 35V	●		
	1	10 seconds continuous, Battery input Voltage < 18V	●		
	(Results / Symptoms) 1. Control Function – Disabled startup (Checking list) 1. Checking battery voltage 2. CN-58A (#1) – CN-36 (07 fuse) Checking Open/Short 3. CN-58A (#2) – CN-36 (07 fuse) Checking Open/Short				
707	1	(In the 500rpm or more) 10 seconds continuous, Alternator Node I Measurement Voltage < 18V	●		
	(Results / Symptoms) 1. Control Function – Battery charging circuit failure (Checking list) 1. CN-58B (#33) – CN-04 (#18) Checking Open/Short 2. CN-04 (#18) – CN-74 (#2) Checking Open/Short				
728	3	10 seconds continuous, Boom position sensor signal voltage Measurement Voltage > 5.0V	●		
	4	10 seconds continuous, Boom position sensor signal voltage Measurement Voltage < 0.3V	●		
	(Results / Symptoms) 1. Monitor – Boom position sensor signal voltage display failure 2. Control Function – No calibration angle sensor, No calibration boom pressure , Boom Detent operation failure, Soft end stop(Boom) operation failure, Lock-up clutch operation failure (Checking list) 1. CN-58B (#37) – CN-100 (B) Checking Open/Short 2. CN-58A (#5) – CN-100 (C) Checking Open/Short 3. CN-58B (#25) – CN-100 (A) Checking Open/Short				
729	3	10 seconds continuous, Bucket position sensor signal voltage Measurement Voltage > 5.0V	●		
	4	10 seconds continuous, Bucket position sensor signal voltage Measurement Voltage < 0.3V	●		
	(Results /Symptoms) 1. Monitor – Bucket position sensor signal voltage display failure 2. Control Function – No calibration angle sensor, Bucket Detent operation failure, Soft end stop(Bucket) operation failure (Checking list) 1. CN-58B(#30) – CN-101(B) Checking Open/Short 2. CN-58A(#5) – CN-101(C) Checking Open/Short 3. CN-58B(#25) – CN-101(A) Checking Open/Short				

G : General    C : Cummins Engine application equipment    S : Scania Engine application equipment

DTC		Diagnostic Criteria	Application		
HCESPN	FMI		G	C	S
831	2	(When mounting the A/C Controller) 10 seconds continuous, A/C controller Communication Data Error	●		
	(Results / Symptoms) 1. Control Function – A/C Controller malfunction				
841	2	10 seconds continuous, ECM Communication Data Error	●		
	(Results / Symptoms) 1. Control Function – ECM operation failure				
842	2	10 seconds continuous, TCU Communication Data Error	●		
	(Results / Symptoms) 1. Control Function – TCU operation failure				
844	2	10 seconds continuous, Monitor Communication Data Error	●		
	(Results / Symptoms) 1. Control Function – Monitor operation failure				
850	2	(When mounting the RMCU) 90 seconds continuous, RMCU Communication Data Error	●		
	(Results / Symptoms) 1. Control Function – RMCU operation failure				
861	2	(When mounting the EHCU) 10 seconds continuous, EHCU Communication Data Error	●		
	(Results / Symptoms) 1. Control Function – EHCU operation failure				
869	2	(When mounting the BKCU) 10 seconds continuous, BKCU Communication Data Error	●		
	(Results / Symptoms) 1. Control Function – BKCU operation failure				

G : General    C : Cummins Engine application equipment    S : Scania Engine application equipment

## 1-2) EHCU FAULT CODE

HCESPN	FMI	Description
2333	9	Communication timeout between EHCU and TCU
2331	9	Communication timeout between EHCU and MCU
2332	9	Communication timeout between EHCU and working joystick
2317	9	Communication timeout between EHCU and steering joystick
2319	2	Steering joystick position signal error
2320	2	Steering joystick - FNR enable switch error
2321	2	Steering joystick - forward switch error
2322	2	Steering joystick - neutral switch error
2323	2	Steering joystick - reverse switch error
2324	2	Steering joystick - kick down switch error
2325	2	Steering joystick - steering on switch error
2326	5	PVE coil power current below normal or open circuit
2326	6	PVE coil power current above normal or grounded circuit
2327	0	PVE coil PWM duty cycle input value above normal operation range
2327	1	PVE coil PWM duty cycle input value below normal operation range
2327	5	PVE coil PWM duty cycle current below normal or open circuit
2327	6	PVE coil PWM duty cycle current above normal or grounded circuit
2327	14	PVE coil PWM duty cycle control block parameter invalid
2311	2	Boom joystick position signal error
2311	0	Boom joystick position input value above normal operation range
2311	1	Boom joystick position input value below normal operation range
2311	3	Boom joystick position input voltage above normal or shorted to high source
2311	4	Boom joystick position input voltage below normal or shorted to low source
2311	13	Boom joystick position control block out of calibration
2311	14	Boom joystick position control block parameter invalid
2311	31	Boom joystick position signal redundancy lost
2313	2	Bucket joystick position signal error
2313	0	Bucket joystick position input value above normal operation range
2313	1	Bucket joystick position input value below normal operation range
2313	3	Bucket joystick position input voltage above normal or shorted to high source
2313	4	Bucket joystick position input voltage below normal or shorted to low source
2313	13	Bucket joystick position control block out of calibration
2313	14	Bucket joystick position control block parameter invalid
2313	31	Bucket joystick position signal redundancy lost
2315	2	Aux joystick position signal error
2315	0	Aux joystick position input value above normal operation range
2315	1	Aux joystick position input value below normal operation range

HCESPN	FMI	Description
2315	3	Aux joystick position input voltage above normal or shorted to high source
2315	4	Aux joystick position input voltage below normal or shorted to low source
2315	13	Aux joystick position control block out of calibration
2315	14	Aux joystick position control block parameter invalid
2315	31	Aux joystick position signal redundancy lost
2304	0	Boom up EPPR valve input value above normal operation range
2304	1	Boom up EPPR valve input value below normal operation range
2304	5	Boom up EPPR valve input current below normal or open circuit
2304	6	Boom up EPPR valve input current above normal or grounded circuit
2304	14	Boom up EPPR valve block parameter invalid
2305	0	Boom down EPPR valve input value above normal operation range
2305	1	Boom down EPPR valve input value below normal operation range
2305	5	Boom down EPPR valve input current below normal or open circuit
2305	6	Boom down EPPR valve input current above normal or grounded circuit
2305	14	Boom down EPPR valve block parameter invalid
2306	0	Bucket in EPPR valve input value above normal operation range
2306	1	Bucket in EPPR valve input value below normal operation range
2306	5	Bucket in EPPR valve input current below normal or open circuit
2306	6	Bucket in EPPR valve input current above normal or grounded circuit
2306	14	Bucket in EPPR valve block parameter invalid
2307	0	Bucket dump EPPR valve input value above normal operation range
2307	1	Bucket dump EPPR valve input value below normal operation range
2307	5	Bucket dump EPPR valve input current below normal or open circuit
2307	6	Bucket dump EPPR valve input current above normal or grounded circuit
2307	14	Bucket dump EPPR valve block parameter invalid
2308	0	Aux. Up EPPR valve input value above normal operation range
2308	1	Aux. Up EPPR valve input value below normal operation range
2308	5	Aux. Up EPPR valve input current below normal or open circuit
2308	6	Aux. Up EPPR valve input current above normal or grounded circuit
2308	14	Aux. Up EPPR valve block parameter invalid
2309	0	Aux. Down EPPR valve input data above normal operation range
2309	1	Aux. Down EPPR valve input data below normal operation range
2309	5	Aux. Down EPPR valve input current below normal or open circuit
2309	6	Aux. Down EPPR valve input current above normal or grounded circuit
2309	14	Aux. Down EPPR valve block parameter invalid
2328	0	EHCUC sensor power voltage high
2328	1	EHCUC sensor power voltage low
2328	3	EHCUC sensor power voltage above normal or shorted to high source

HCESPN	FMI	Description
2328	4	EHCU sensor power voltage below normal or shorted to low source
2329	0	EHCU power voltage high
2329	1	EHCU power voltage low
2329	11	EHCU safety cpu error
739	2	Armrest switch signal error
2334	0	Steering pilot pressure sensor data above normal range
2334	1	Steering pilot pressure sensor data below normal range
2335	2	Steering proportional valve moving position error
2335	14	Steering proportional valve start position error

### 1-3) AAVM FAULT CODE

Fault Code	Description
A01	AAVM Communication Error -AAVM
A02	AAVM Communication Error -Front Camera
A03	AAVM Communication Error -Rear Camera
A04	AAVM Communication Error -Left Camera
A05	AAVM Communication Error -Right Camera
A06	Manual Setting Fail
A07	No MCU CID
A08	MCU CID Format Error
A09	AAVM Hardware Error -AAVM
A10	AAVM Hardware Error -Front Camera
A11	AAVM Hardware Error -Rear Camera
A12	AAVM Hardware Error -Left Camera
A13	AAVM Hardware Error -Right Camera
A14	MCU CID Model is not registered
A15	MCU CID Model can't be applied

## 2) ENGINE FAULT CODE

Fault code J1939 SPN J1939 FMI	Reason	Effect (only when fault code is active)
111 629 12	Engine control module critical internal failure - Bad intelligent device or component. Error internal to the ECM related to memory hardware failures or internal ECM voltage supply circuits.	Possible no noticeable performance effects, engine dying, or hard starting.
115 612 2	Engine magnetic crankshaft speed/position lost both of two signals - Data erratic, intermittent, or incorrect. The ECM has detected the primary and backup speed sensor signals are connected backwards.	The engine will shut down or will not start.
122 102 3	Intake manifold 1 pressure sensor circuit - Voltage above normal, or shorted to high source. High signal voltage detected at the intake manifold pressure circuit.	Engine power derate.
123 102 4	Intake manifold 1 pressure sensor circuit - Voltage below normal, or shorted to low Source. Low signal voltage or open circuit detected at the intake manifold pressure circuit.	Engine power derate.
124 102 16	Intake manifold 1 pressure - Data valid but above normal operational range - Moderately severe level. Intake manifold pressure is above the maximum operating limit.	Engine power derate.
125 102 18	Intake Manifold 1 Pressure - Data valid but below normal operating range - Moderately severe level. Intake manifold pressure is below the minimum operating limit.	Engine power derate.
131 91 3	Accelerator pedal or lever position sensor 1 circuit - Voltage above normal, or shorted to high source. High voltage detected at accelerator pedal position number 1 circuit.	The engine will operate in limp home mode.
132 91 4	Accelerator pedal or lever position sensor 1 circuit - Voltage below normal, or shorted to low source. Low voltage detected at accelerator pedal position number 1 signal circuit.	The engine will operate in limp home mode.
133 974 3	Remote accelerator pedal or lever position sensor 1 circuit - Voltage above normal, or shorted to high source. High voltage detected at remote accelerator pedal position signal circuit.	Remote accelerator will not operate.
134 974 4	Remote accelerator pedal or lever position sensor 1 circuit - Voltage below normal, or shorted to low source. Low voltage detected at remote accelerator pedal position signal circuit.	Remote accelerator will not operate.
143 100 18	Engine oil rifle pressure - Data valid but below normal operational range - Moderately severe level. Engine oil pressure signal indicates engine oil pressure is below the engine protection warning limit.	Engine power derate.

※ Some fault codes are not applied to this machine.



Fault code J1939 SPN J1939 FMI	Reason	Effect (only when fault code is active)
144 110 3	Engine coolant temperature 1 sensor circuit - Voltage above normal, or shorted to high source. High signal voltage or open circuit detected at engine coolant temperature circuit.	Fan will stay ON if controlled by ECM.
145 110 4	Engine coolant temperature 1 sensor circuit - Voltage below normal, or shorted to low source. Low signal voltage detected at engine coolant temperature circuit.	Fan will stay ON if controlled by ECM.
146 110 16	Engine coolant temperature - Data valid but above normal operational range - Moderately severe level. Engine coolant temperature is above engine protection warning limit.	Progressive power and/or speed derate increasing in severity from time of alert. If the engine protection shutdown feature is enabled, the engine will shut down 30 seconds after the red stop lamp starts flashing.
151 110 0	Engine coolant temperature - Data valid but above normal operational range - Most severe level. Engine coolant temperature signal indicates engine coolant temperature above engine protection critical limit.	Progressive power and/or speed derate increasing in severity from time of alert. If the engine protection shutdown feature is enabled, the engine will shut down 30 seconds after the red stop lamp starts flashing.
153 105 3	Intake manifold 1 temperature sensor circuit - Voltage above normal, or shorted to high source. High signal voltage detected at intake manifold air temperature circuit.	Fan will stay ON if controlled by ECM.
154 105 4	Intake manifold 1 temperature sensor circuit - Voltage below normal, or shorted to low source. Low signal voltage detected at intake manifold air temperature circuit.	Fan will stay ON if controlled by ECM.
155 105 0	Intake manifold 1 temperature - Data valid but above normal operational range - Most severe level. Intake manifold air temperature signal indicates intake manifold air temperature above engine protection critical limit.	Progressive power and/or speed derate increasing in severity from time of alert. If the engine protection shutdown feature is enabled, the engine will shut down 30 seconds after the red stop lamp starts flashing.
175 3464 3	Electronic throttle control actuator driver circuit - Voltage above normal, or shorted to high source. A short circuit to battery or open circuit has been detected in the engine intake air throttle actuator signal circuit.	Possible reduced engine performance.
176 3464 4	Electronic throttle control actuator driver circuit - Voltage below normal, or shorted to low source. A short circuit to ground has been detected in the engine intake air throttle actuator signal circuit.	Possible reduced engine performance.
177 3464 7	Electronic throttle control actuator - Mechanical system not responding or out of adjustment. The engine intake air throttle actuator has failed the auto zero span check.	Possible reduced engine performance.
187 3510 4	Sensor supply 2 circuit - Voltage below normal, or shorted to low source. Low voltage detected at the sensor supply number 2 circuit.	Engine power derate.
195 111 3	Coolant level sensor 1 circuit - Voltage above normal, or shorted to high source. High signal voltage detected at engine coolant level circuit.	None on performance.

※ Some fault codes are not applied to this machine.

Fault code J1939 SPN J1939 FMI	Reason	Effect (only when fault code is active)
196 111 4	Coolant level sensor 1 circuit - Voltage below normal, or shorted to low source. Low signal voltage detected at engine coolant level circuit.	None on performance.
197 111 18	Coolant level - Data valid but below normal operational range - Moderately severe level. Low coolant level has been detected.	Engine power derate.
221 108 3	Barometric pressure sensor circuit - Voltage above normal, or shorted to high source. High signal voltage detected at barometric pressure circuit.	Engine power derate.
222 108 4	Barometric pressure sensor circuit - Voltage below normal, or shorted to low source. Low signal voltage detected at barometric pressure circuit.	Engine power derate.
227 3510 3	Sensor supply 2 circuit - Voltage above normal, or shorted to high source. High voltage detected at sensor supply number 2 circuit.	Engine power derate.
234 190 0	Engine crankshaft speed/position - Data valid but above normal operational range - Most severe level. Engine speed signal indicates engine speed above engine protection limit.	Engine power derate.
238 3511 4	Sensor supply 3 circuit - Voltage below normal, or shorted to low source. Low voltage detected on the +5 volt sensor supply circuit to the engine speed sensor.	Engine may run rough, may stop running, may not start, or may be difficult to start.
239 3511 3	Sensor supply 3 circuit - Voltage above normal or shorted to high source. High voltage detected on the 5 volt sensor supply circuit to the engine speed sensor.	Engine may run rough, may stop running, may not start, or may be difficult to start.
241 84 2	Wheel-based vehicle speed - Data erratic, intermittent, or incorrect. The ECM lost the vehicle speed signal or is reading an erratic value.	Engine speed limited to ,maximum engine speed without VSS parameter value. Cruise control, gear-down protection, and road speed governor will not work.
245 647 4	Fan control circuit - Voltage below normal, or shorted to low source. Low signal voltage detected at the fan control circuit when commanded on.	The fan may stay on continuously or not run at all.
249 171 3	Ambient air temperature sensor 1 circuit - Voltage above normal or shorted to high source. High signal voltage detected at ambient air temperature circuit.	Possible reduced engine performance.
256 171 4	Ambient air temperature sensor 1 circuit - Voltage below normal or shorted to low source. Low voltage detected at ambient air temperature circuit.	Possible reduced engine performance.
271 1347 4	Fuel pump pressurizing assembly 1 circuit - Voltage below normal, or shorted to low source. Low signal voltage detected at the fuel pump actuator circuit.	Engine power derate.

※ Some fault codes are not applied to this machine.

Fault code J1939 SPN J1939 FMI	Reason	Effect (only when fault code is active)
272 1347 3	Fuel pump pressurizing assembly 1 circuit - Voltage above normal, or shorted to high source. High signal voltage or open circuit detected at the fuel pump actuator circuit.	Engine may run rough, may stop running, may not start, or may be difficult to start.
285 639 9	SAE J1939 multiplexing PGN timeout error - Abnormal update rate. The ECM expected information from a multiplexed device but did not receive it soon enough or did not receive it at all.	At least one multiplexed device will not operate properly.
286 639 13	SAE J1939 multiplexing configuration error - Out of calibration. The ECM expected information from a multiplexed device but only received a portion of the necessary information.	At least one multiplexed device will not operate properly.
288 974 19	Sae J1939 multiplexing remote accelerator pedal or lever position sensor circuit - Received network data in error. The oem vehicle electronic control unit (VECM) detected a fault with the remote accelerator.	Remote accelerator will not operate.
295 108 2	Barometric pressure - Data erratic, intermittent, or incorrect. An error in the barometric pressure sensor signal was detected by the ECM.	Engine power derate.
322 651 5	Injector solenoid driver cylinder 1 circuit - Current below normal, or open circuit. Current detected at injector 1 when voltage is turned OFF.	Engine power derate.
323 655 5	Injector solenoid driver cylinder 5 circuit - Current below normal, or open circuit. Current detected at injector 5 when voltage is turned OFF.	The current to the injector is shut OFF. Engine power derate.
324 653 5	Injector solenoid driver cylinder 3 circuit - Current below normal, or open circuit. Current detected at injector 3 when voltage is turned OFF.	The current to the injector is shut OFF. Engine power derate.
325 656 5	Injector solenoid driver cylinder 6 circuit - Current below normal, or open circuit. Current detected at injector 6 when voltage is turned OFF.	The current to the injector is shut OFF. Engine power derate.
331 652 5	Injector solenoid driver cylinder 2 circuit - Current below normal, or open circuit. Current detected at injector 2 when voltage is turned OFF.	The current to the injector is shut OFF. Engine power derate.
332 654 5	Injector solenoid driver cylinder 4 circuit - Current below normal, or open circuit. Current detected at injector 4 when voltage is turned OFF.	The current to the injector is shut OFF. Engine power derate.
334 110 2	Engine coolant temperature - Data erratic, intermittent, or incorrect. The engine coolant temperature sensor is reading an erratic value at initial key ON.	None on performance.

※ Some fault codes are not applied to this machine.

Fault code J1939 SPN J1939 FMI	Reason	Effect (only when fault code is active)
338 1267 3	Idle shutdown vehicle accessories relay driver circuit - Voltage above normal, or shorted to high source. Open circuit or short to voltage source detected at the idle shutdown vehicle accessory/ignition bus relay circuit.	Vehicle accessories or ignition bus loads controlled by the idle shutdown relay will not power up.
339 1267 4	Idle shutdown vehicle accessories relay driver circuit - Voltage below normal, or shorted to low source. Low voltage detected at the idle shutdown vehicle accessory or ignition bus relay circuit when commanded ON.	Vehicle accessories or ignition bus loads controlled by the idle shutdown relay will not power up.
343 629 12	Engine control module warning internal hardware failure - Bad intelligent device or component. ECM power supply errors have been detected.	Engine power derate.
346 630 12	Engine control module calibration memory software - Bad intelligent device or component. Invalid switch configuration adjustable parameter setting have been detected by the engine control module (ECM).	Various optional switch inputs to the ECM may not operate correctly.
351 627 12	Injector power supply - Bad intelligent device or component. The ECM measured injector boost voltage is low.	Engine power derate.
352 3509 4	Sensor supply 1 circuit - Voltage below normal, or shorted to low source. Low voltage detected at sensor supply number 1 circuit.	Engine power derate.
383 729 5	Engine intake air heater 1 circuit - Current below normal or open circuit. A malfunctioning engine intake air heater circuit has been detected.	Engine may not start or may be difficult to start.
386 3509 3	Sensor supply 1 circuit - Voltage above normal, or shorted to high source. High voltage detected at sensor supply number 1 circuit.	Engine power derate.
415 100 1	Engine oil rifle pressure - Data valid but below normal operational range - Most severe level. Oil pressure signal indicates oil pressure below the engine protection critical limit.	Progressive power and/or speed derate increasing in severity from time of alert. If engine protection shutdown feature is enabled, engine will shut down 30 seconds after red stop lamp starts flashing.
418 97 15	Water in fuel indicator - Data valid but above normal operational range - Least severe level. water has been detected in the fuel filter.	None on performance.
427 639 9	J1939 data link - Abnormal update rate. Communication between the engine control module (ECM) and another device on the SAE J1939 data link has been lost.	Engine will only idle.
428 97 3	Water in fuel indicator sensor circuit - Voltage above normal, or shorted to high source. High voltage detected at the water in fuel circuit.	None on performance. No water in fuel warning available.
435 100 2	Engine oil rifle pressure - Data erratic, intermittent, or incorrect. The engine oil pressure sensor is reading an erratic value.	None on performance.

※ Some fault codes are not applied to this machine.

Fault code J1939 SPN J1939 FMI	Reason	Effect (only when fault code is active)
436 105 2	Intake manifold 1 temperature - Data erratic, intermittent, or incorrect. The intake manifold temperature sensor is reading an erratic value at initial key on or while the engine is running.	Possible reduced engine performance.
441 168 18	Battery 1 voltage - Data valid but below normal operational range - Moderately severe level. ECM supply voltage is below the minimum system voltage level.	Engine may run rough, may stop running, may not start, or may be difficult to start.
442 168 16	Battery 1 Voltage - Data valid but above normal operational range - Moderately severe level. ECM supply voltage is above the maximum system voltage level.	None on performance.
451 157 3	Injector metering rail 1 pressure sensor circuit - Voltage above normal, or shorted to high source. High signal voltage detected at the rail fuel pressure sensor circuit.	Power and/or speed derate.
452 157 4	Injector metering rail 1 pressure sensor circuit - Voltage below normal, or shorted to low source. Low signal voltage detected at the rail fuel pressure sensor circuit.	Power and/or speed derate.
483 1349 3	Injector metering rail 2 pressure sensor circuit - Voltage above normal or shorted to high source. High signal voltage detected at the fuel rail 2 pressure sensor circuit.	Possible reduced engine performance.
484 1349 4	Injector metering rail 2 pressure sensor circuit - Voltage below normal or shorted to low source. Low signal voltage detected at the fuel rail 2 pressure sensor circuit.	Possible reduced engine performance.
515 3514 3	Sensor supply 6 circuit - Voltage above normal or shorted to high source. High voltage detected on the +5 volt sensor supply circuit to the fuel rail pressure sensor.	Engine power derate.
516 3514 4	Sensor supply 6 circuit - Voltage below normal or shorted to low source. Low voltage detected on the +5 volt sensor supply circuit to the fuel rail pressure sensor.	Engine power derate.
553 157 16	Injector metering rail 1 pressure - Data valid but above normal operational range - Moderately severe level. The ECM has detected that fuel pressure is higher than commanded pressure.	Possible reduced engine performance.
555 101 16	Crankcase pressure - Data valid but above normal operational range - Moderately severe level. The crankcase breather filter requires maintenance.	None on performance.
556 101 0	Crankcase pressure - Data valid but above normal operational range - Most severe level. The crankcase breather filter requires maintenance.	None on performance.

※ Some fault codes are not applied to this machine.

Fault code J1939 SPN J1939 FMI	Reason	Effect (only when fault code is active)
559 157 18	Injector metering rail 1 pressure - Data valid but below normal operational range - Moderately severe level. The ecm has detected that fuel pressure is lower than commanded pressure.	Possibly hard to start or low power. Engine could possibly <b>not</b> start.
584 677 3	Starter relay driver circuit - Voltage above normal, or shorted to high source. Open circuit or high voltage detected at starter lockout circuit.	Either the engine will not start or the engine will not have starter lockout protection.
585 677 4	Starter relay driver circuit - Voltage below normal, or shorted to low source. Low voltage detected at starter lockout circuit.	Either the engine will not start or the engine will not have starter lockout protection.
595 103 16	Turbocharger 1 speed - Data valid but above normal operating range - Moderately severe level. High turbocharger speed has been detected by the ecm.	Engine power derate.
596 167 16	Electrical charging system voltage - Data valid but above normal operational range - Moderately severe level. High battery voltage detected by the battery voltage monitor feature.	None on performance.
597 167 18	Electrical charging system voltage - Data valid but below normal operational range - Moderately severe level. Low battery voltage detected by the battery voltage monitor feature.	None on performance.
649 1378 31	Engine oil change interval - Condition exists. Change engine oil and filter.	None on performance.
687 103 18	Turbocharger 1 speed - Data valid but below normal operational range - Moderately severe level. Low turbocharger speed detected by the ECM.	Engine power derate. The ECM uses an estimated turbocharger speed.
689 190 2	Engine crankshaft speed/position - Data erratic, intermittent, or incorrect. The ECM has detected an error in the engine speed signal.	Possible reduced engine performance.
691 1172 3	Turbocharger 1 compressor inlet temperature sensor circuit - Voltage above normal, or shorted to high source. High signal voltage detected at turbocharger compressor inlet air temperature circuit.	Engine power derate.
692 1172 4	Turbocharger 1 compressor inlet temperature circuit - Voltage below normal, or shorted to low source. Low signal voltage detected at turbocharger compressor inlet air temperature circuit.	Engine power derate.
693 1172 2	Turbocharger 1 compressor intake temperature - Data erratic, intermittent, or incorrect. A temperature too high or low for the operating conditions has been detected by the turbocharger compressor intake temperature sensor.	Possible reduced engine performance.

※ Some fault codes are not applied to this machine.



Fault code J1939 SPN J1939 FMI	Reason	Effect (only when fault code is active)
731 723 7	Engine speed / position camshaft and crankshaft misalignment - Mechanical system not responding properly or out of adjustment. Engine position signal from the crankshaft position sensor and camshaft position sensor do not match.	Engine power derate.
755 157 7	Injector metering rail 1 pressure - Mechanical system not responding or out of adjustment. The ecm has detected a difference in the 2 fuel rail pressure signals.	Possible reduced engine performance.
778 723 2	Engine camshaft speed / position sensor - Data erratic, intermittent, or incorrect. The ECM has detected an error in the camshaft position sensor signal.	Possible reduced engine performance.
784 1590 2	Adaptive cruise control mode - Data erratic, intermittent, or incorrect. Loss of communication with adaptive cruise control.	Adaptive cruise control will not operate. Standard cruise control may not operate.
1117 627 2	Power supply lost with ignition on - Data erratic, intermittent, or incorrect. Supply voltage to the ECM fell below 6.2 volts momentarily, or the ECM was not allowed to power down correctly (retain battery voltage for 30 seconds after key OFF).	Possible no noticeable performance.
1139 651 7	Injector solenoid driver cylinder 1 - Mechanical system not responding or out of adjustment. The ECM has detected an error with the injection timing or quantity.	Possible reduced engine performance.
1141 652 7	Injector solenoid driver cylinder 2 - Mechanical system not responding or out of adjustment. The ECM has detected an error with the injection timing or quantity.	Possible reduced engine performance.
1142 653 7	Injector solenoid driver cylinder 3 - Mechanical system not responding or out of adjustment. The ECM has detected an error with the injection timing or quantity.	Possible reduced engine performance.
1143 654 7	Injector solenoid driver cylinder 4 - Mechanical system not responding or out of adjustment. The ECM has detected an error with the injection timing or quantity.	Possible reduced engine performance.
1144 655 7	Injector solenoid driver cylinder 5 - Mechanical system not responding or out of adjustment. The ECM has detected an error with the injection timing or quantity.	Possible reduced engine performance.
1145 656 7	Injector solenoid driver cylinder 6 - Mechanical system not responding or out of adjustment. The ECM has detected an error with the injection timing or quantity.	Possible reduced engine performance.
1228 27 2	Egr valve position - Data erratic, intermittent, or Incorrect. The EGR valve is unable to meet commanded position.	Possible reduced engine performance.

※ Some fault codes are not applied to this machine.

Fault code J1939 SPN J1939 FMI	Reason	Effect (only when fault code is active)
1239 2623 3	Accelerator pedal or lever position sensor 2 circuit - Voltage above normal or shorted to high source. High voltage detected at accelerator pedal position number 2 signal circuit.	The engine will operate in limp home mode.
1241 2623 4	Accelerator pedal or lever position sensor 2 circuit - Voltage below normal or shorted to low source. Low voltage detected at accelerator pedal position number 2 signal circuit.	The engine will operate in limp home mode.
1242 91 2	Accelerator pedal or lever position sensor 1 and 2 - Data erratic, intermittent, or incorrect. Accelerator position sensor number 1 and number 2 are reading different values.	The engine will only idle.
1515 91 19	Sae J1939 multiplexed accelerator pedal or lever sensor system - Received network data in error. The J1939 multiplexing controller has indicated a malfunction of the multiplexed accelerator pedal.	The engine will only idle.
1654 1323 31	Engine misfire cylinder 1 - Condition exists. Engine misfire has been detected in cylinder number 1.	Possible reduced engine performance.
1655 1324 31	Engine misfire cylinder 2 - Condition exists. Engine misfire has been detected in cylinder number 2.	Possible reduced engine performance.
1656 1325 31	Engine misfire cylinder 3 - Condition exists. Engine misfire has been detected in cylinder number 3.	Possible reduced engine performance.
1657 1326 31	Engine misfire cylinder 4 - Condition exists. Engine misfire has been detected in cylinder number 4.	Possible reduced engine performance.
1658 1327 31	Engine misfire cylinder 5 - Condition exists. Engine misfire has been detected in cylinder number 5.	Possible reduced engine performance.
1659 1328 31	Engine misfire cylinder 6 - Condition exists. Engine misfire has been detected in cylinder number 6.	Possible reduced engine performance.
1668 1761 4	Aftertreatment diesel exhaust fluid tank level sensor circuit - Voltage below normal or shorted to low source. Low signal voltage detected at the aftertreatment diesel exhaust fluid tank level sensor circuit.	Possible reduced engine performance.
1669 1761 3	Aftertreatment diesel exhaust fluid tank level sensor circuit - Voltage above normal or shorted to high source. High signal voltage detected at the catalyst tank level sensor circuit.	Possible reduced engine performance.
1673 1761 1	Aftertreatment diesel exhaust fluid tank level - Data valid but below normal operating range - Most severe level. The aftertreatment diesel exhaust fluid tank level has fallen below the critical warning level.	Possible reduced engine performance.

※ Some fault codes are not applied to this machine.



Fault code J1939 SPN J1939 FMI	Reason	Effect (only when fault code is active)
1677 3031 4	Aftertreatment diesel exhaust fluid tank temperature sensor - Voltage below normal or shorted to low source. Low signal voltage detected at the diesel exhaust fluid tank temperature sensor circuit.	Possible reduced engine performance.
1678 3031 3	Aftertreatment diesel exhaust fluid tank temperature sensor - Voltage above normal or shorted to high source. High signal voltage or open circuit detected at the diesel exhaust fluid tank temperature sensor circuit.	Possible reduced engine performance.
1679 3031 2	Aftertreatment diesel exhaust fluid tank temperature - Data erratic, intermittent, or incorrect. The diesel exhaust fluid tank temperature sensor has indicated a tank temperature too high or too low for the ambient conditions.	Possible reduced engine performance.
1682 3362 31	Aftertreatment diesel exhaust fluid dosing unit input lines - Condition exists. The aftertreatment diesel exhaust fluid dosing unit is unable to prime.	Possible reduced engine performance.
1683 3363 3	Aftertreatment diesel exhaust fluid tank heater - Voltage above normal or shorted to high source. High signal voltage detected at the aftertreatment diesel exhaust fluid tank heater circuit.	Possible reduced engine performance.
1684 3363 4	Aftertreatment diesel exhaust fluid tank heater - Voltage below normal, or shorted to low source. Low signal voltage detected at the aftertreatment diesel exhaust fluid tank heater circuit.	Possible reduced engine performance.
1691 100 18	Aftertreatment diesel oxidation catalyst conversion efficiency - Data valid but below normal operating range - Moderately severe level. The temperature increase across the aftertreatment catalyst is lower than expected.	Possible frequent need for aftertreatment regeneration.
1695 3513 3	Sensor supply 5 - Voltage above normal or shorted to high source. High voltage detected at sensor supply 5 circuit in the oem harness.	the engine will operate in limp home mode.
1696 3513 4	Sensor supply 5 - Voltage below normal or shorted to low source. Low voltage detected at sensor supply number 5 circuit in the oem harness.	the engine will operate in limp home mode.
1712 3363 18	Aftertreatment diesel exhaust fluid tank heater - Data valid but below normal operating range - Moderately severe level. The aftertreatment diesel exhaust fluid tank heater is unable to thaw the frozen diesel exhaust fluid.	Possible reduced engine performance.

※ Some fault codes are not applied to this machine.

Fault code J1939 SPN J1939 FMI	Reason	Effect (only when fault code is active)
1713 3363 16	Aftertreatment diesel exhaust fluid tank heater - Data valid but above normal operating range - Moderately severe level. The diesel exhaust fluid tank heater is continuously in the on position.	None on performance.
1718 1322 31	Engine misfire for multiple cylinders - Condition exists. Engine misfire has been detected in multiple cylinder numbers.	Possible reduced engine performance.
1776 2634 3	Power relay driver circuit - Voltage above normal or shorted to high source. High voltage detected at power relay driver circuit.	Possible reduced engine performance.
1777 2634 4	Power relay driver circuit - Voltage below normal or shorted to low source. An open circuit or low voltage has been detected at the power relay circuit.	Possible reduced engine performance.
1843 101 3	Crankcase pressure circuit - Voltage above normal or shorted to high source. High signal voltage detected at the crankcase pressure circuit.	None on performance.
1844 101 4	Crankcase pressure circuit - Voltage below normal or shorted to low source. Low signal voltage detected at the crankcase pressure circuit.	None on performance.
1866 411 2	Exhaust gas recirculation valve delta pressure - Data erratic, intermittent, or incorrect. An error in the egr delta pressure signal was detected at initial key on or the sensor failed the autozero test.	possible reduced engine performance.
1867 412 2	Engine gas recirculation temperature - Data erratic, intermittent, or incorrect. Engine misfire has been detected in multiple cylinder numbers.	Possible reduced engine performance.
1879 3251 3	Aftertreatment diesel particulate filter differential pressure sensor circuit - Voltage above normal or shorted to high source. High signal voltage detected at the aftertreatment differential pressure sensor circuit.	possible reduced engine performance.
1881 3251 4	Aftertreatment diesel particulate filter differential pressure sensor circuit - Voltage below normal or shorted to low source. Low signal voltage or open circuit detected at the aftertreatment differential pressure sensor circuit.	possible reduced engine performance.
1883 3251 2	Aftertreatment diesel particulate filter differential pressure sensor - Data erratic, intermittent, or incorrect. The aftertreatment diesel particulate filter differential pressure sensor is reading an erratic value at initial key on or during engine operation.	possible reduced engine performance.

※ Some fault codes are not applied to this machine.

Fault code J1939 SPN J1939 FMI	Reason	Effect (only when fault code is active)
1885 3216 4	Aftertreatment intake NOx sensor circuit - Voltage below normal or shorted to low source. An internal circuit error has been detected by the aftertreatment intake NOx sensor.	Possible reduced engine performance.
1887 3226 4	Aftertreatment outlet NOx sensor circuit - Voltage below normal or shorted to low source. An internal circuit error has been detected by the aftertreatment outlet NOx sensor.	Possible reduced engine performance.
1896 2791 13	EGR valve controller - Out of calibration. The EGR valve has failed the automatic calibration procedure at initial key ON.	Possible reduced engine performance.
1921 3251 0	Aftertreatment diesel particulate filter differential pressure - Data valid but above normal operating range - Moderately severe level. The soot load of the aftertreatment diesel particulate filter has exceeded the recommended limits.	Possible reduced engine performance.
1922 3251 0	Aftertreatment diesel particulate filter differential pressure - Data valid but above normal operating range - Most severe level. The soot load of the aftertreatment diesel particulate filter has exceeded the recommended limits. Engine protection derate is enabled.	Possible reduced engine performance.
1938 3597 1	Ecu power output supply voltage 1 - Data valid but below normal operational range - Moderately severe level. Low battery voltage detected by the VGT actuator.	Possible reduced engine performance.
1942 101 2	Crankcase pressure - Data erratic, intermittent, or incorrect. The ECM has detected that the crankcase pressure signal is reading an erratic value at initial key ON or during engine operation.	None on performance.
1961 2791 0	EGR valve control circuit calculated over temperature - Data valid but above normal operational range - Least severe level. High EGR valve driver temperature has been detected.	Possible reduced engine performance.
1962 641 0	VGT Actuator driver over temperature (calculated) - Data valid but above normal operating range - Least severe level. High internal VGT actuator temperature has been detected.	None on performance.
1974 101 16	Crankcase pressure - Data valid but above normal operating range - Moderately severe level. The crankcase breather filter requires maintenance.	None on performance.

※ Some fault codes are not applied to this machine.

Fault code J1939 SPN J1939 FMI	Reason	Effect (only when fault code is active)
1993 4795 31	Aftertreatment diesel particulate filter missing - Condition exists. The aftertreatment diesel particulate filter in the exhaust system is not present.	Active aftertreatment diesel particulate filter regeneration will be disabled.
2185 3512 3	Sensor supply 4 circuit - Voltage above normal, or shorted to high source. High voltage detected at 5 VDC sensor supply circuit to the accelerator pedal position sensor.	Engine will only idle.
2186 3512 4	Sensor supply 4 circuit - Voltage below normal, or shorted to low source. Low voltage detected at 5 VDC sensor supply circuit to the accelerator pedal position sensor.	Engine will only idle.
2198 641 11	VGT Actuator driver circuit - Root cause not known. Intermittent communication between the smart VGT controller and the ECM has been detected. The VGT controller is not interpreting the J1939 message from the ECM correctly.	Possible reduced engine performance.
2272 27 4	EGR Valve position circuit - Voltage below normal or shorted to low source. Low signal voltage has been detected at the EGR valve position sensor circuit	Possible reduced engine performance.
2273 411 3	Exhaust gas recirculation valve delta pressure sensor circuit - Voltage above normal or shorted to high source. High signal voltage detected at the EGR differential pressure sensor circuit.	Possible reduced engine performance.
2274 411 4	Exhaust gas recirculation valve delta pressure sensor circuit - Voltage below normal or shorted to low source. Low signal voltage detected at the EGR differential pressure sensor circuit.	Possible reduced engine performance.
2288 103 15	Turbocharger 1 speed - Data valid but above normal operating range - Least severe level. High turbocharger speed has been detected by the ECM.	Possible reduced engine performance.
2311 633 31	Electronic fuel injection control valve circuit - Condition exists. Fuel pump actuator circuit resistance too high or too low, or an intermittent connection has been detected.	Possible reduced engine performance.
2322 723 2	Engine camshaft speed / position sensor - Data erratic, intermittent, or incorrect. Camshaft engine speed sensor intermittent synchronization.	None on performance.
2349 2791 5	EGR Valve control circuit - Current below normal or open circuit. Motor terminal or motor coil open circuit has been detected by the ECM.	Possible reduced engine performance.

※ Some fault codes are not applied to this machine.

Fault code J1939 SPN J1939 FMI	Reason	Effect (only when fault code is active)
2353 2791 6	EGR Valve control circuit - Current above normal or grounded circuit. A short circuit to ground has been detected in the EGR valve motor circuit.	Possible reduced engine performance.
2372 95 16	Fuel filter differential pressure - Data valid but above normal operational range - Moderately severe level. Excessive fuel flow restriction to the high pressure fuel pump has been detected.	Possible reduced engine performance.
2373 1209 3	Exhaust gas pressure sensor circuit - Voltage above normal or shorted to high source. High signal voltage detected at the exhaust gas pressure circuit.	Possible reduced engine performance.
2374 1209 4	Exhaust gas pressure sensor circuit - Voltage below normal or shorted to low source. Low signal voltage detected at the exhaust gas pressure circuit.	Possible reduced engine performance.
2375 412 3	Exhaust gas recirculation temperature sensor circuit - Voltage above normal or shorted to high source. High signal voltage detected at EGR temperature circuit.	Possible reduced engine performance.
2376 412 4	Exhaust gas recirculation temperature sensor circuit - Voltage below normal or shorted to low source. Low signal voltage detected at EGR temperature circuit.	Possible reduced engine performance.
2377 647 3	Fan control circuit - Voltage above normal, or shorted to high source. Open circuit or high voltage detected at the fan control circuit.	The fan can stay on continuously or <b>not</b> run at all.
2387 641 7	VGT Actuator driver circuit (motor) - Mechanical system not responding or out of adjustment. The smart VGT controller has detected incorrect stop limits, or the VGT is unable to move to the closed position.	Possible reduced engine performance.
2398 171 2	Ambient air temperature - Data erratic, intermittent, or incorrect. The ambient air temperature sensor is reading an erratic value.	Possible reduced engine performance.
2448 111 17	Coolant level - Data valid but below normal operational range - Least severe level. Low engine coolant level detected.	none on performance.
2449 641 13	Vgt actuator controller - Out of calibration. The VGT actuator has been installed incorrectly.	Possible reduced engine performance.
2468 102 3	Engine crankshaft speed/position - Data valid but above normal operating range - Moderately severe level. The engine speed has exceeded a critical limit.	Engine will be shut down.
2554 1209 2	Exhaust gas pressure - Data erratic, intermittent or incorrect. The exhaust gas pressure sensor is reading an erratic value.	possible reduced engine performance.

※ Some fault codes are not applied to this machine.

Fault code J1939 SPN J1939 FMI	Reason	Effect (only when fault code is active)
2555 729 3	Intake air heater 1 circuit - Voltage above normal, or shorted to high source. High voltage detected at the intake air heater signal circuit.	The intake air heaters may be ON or OFF all the time.
2556 729 4	Intake air heater 1 circuit - Voltage below normal, or shorted to low source. Low voltage detected at the intake air heater signal circuit.	The intake air heaters may be ON or OFF all the time.
2634 641 12	VGT Actuator controller - Bad intelligent device or component. An internal error has been detected by the smart VGT controller.	Possible reduced engine performance.
2636 641 9	VGT Actuator driver circuit - abnormal update rate. No communications on the J1939 data link between the engine ECM and the smart VGT controller.	Possible reduced engine performance.
2638 5298 17	Aftertreatment diesel oxidation catalyst conversion efficiency - Data valid but below normal operating range - Least severe level. The temperature increase across the aftertreatment diesel oxidation catalyst is lower than expected.	Possible frequent need for aftertreatment regeneration.
2639 3251 15	Aftertreatment diesel particulate filter differential pressure - Data valid but above normal operating range - Least severe level. The soot load of the aftertreatment diesel particulate filter has exceeded the recommended limits.	Possible reduced engine performance.
2646 110 32	Engine coolant temperature - Condition exists. The EGR valve was closed to reduce engine coolant temperature.	Possible reduced engine performance.
2718 520325 31	Brake switch and accelerator pedal position incompatible - Condition exists. The ECM has detected the brake pedal and accelerator pedal were depressed simultaneously.	The engine will operate in limp home mode.
2771 3226 9	Aftertreatment outlet NOx sensor - Abnormal update rate. No communications or an invalid data transfer rate detected on the J1939 data link between the ECM and the aftertreatment outlet NOx sensor.	Possible reduced engine performance.
2777 3703 31	Particulate trap active regeneration inhibited due to inhibit switch - Condition exists. Regeneration of the diesel particulate filter has been prevented due to the permit switch being disabled.	Possible frequent need for aftertreatment regeneration.
2961 412 15	Exhaust gas recirculation temperature - Data valid but above normal operational range - Least severe level. EGR temperature has exceeded the engine protection limit.	Possible reduced engine performance.
2962 412 16	Exhaust gas recirculation temperature - Data valid but above normal operational range - Moderately severe level. EGR temperature has exceeded the engine protection limit.	Possible reduced engine performance.

※ Some fault codes are not applied to this machine.

Fault code J1939 SPN J1939 FMI	Reason	Effect (only when fault code is active)
2963 110 15	Engine coolant temperature - Data valid but above normal operational range - Least severe level. Engine coolant temperature is above the engine protection warning limit.	Progressive power and/or speed derate increasing in severity from time of alert. If the Engine protection shutdown feature is enabled, the engine will shut down 30 seconds after the red STOP lamps starts flashing.
2964 105 15	Intake manifold 1 temperature - Data valid but above normal operational range - Least severe level. Intake manifold air temperature signal indicates intake manifold air temperature is above engine protection warning limit.	Progressive power and/or speed derate increasing in severity from time of alert. If the Engine protection shutdown feature is enabled, the engine will shut down 30 seconds after the red STOP lamps starts flashing.
2973 102 2	Intake manifold 1 pressure - Data erratic, intermittent, or incorrect. The intake manifold pressure sensor is reading an erratic value.	Possible reduced engine performance.
2976 3361 2	Aftertreatment diesel exhaust fluid dosing unit temperature - Data erratic, intermittent, or incorrect. An internal error has been detected in the aftertreatment diesel exhaust fluid dosing unit.	Possible reduced engine performance.
3133 3610 3	Aftertreatment diesel particulate filter outlet pressure sensor circuit - Voltage above normal, or shorted to high source. High signal voltage detected at the aftertreatment diesel particulate filter outlet pressure sensor circuit.	Possible reduced engine performance.
3134 3610 4	Aftertreatment diesel particulate filter outlet pressure sensor circuit - Voltage below normal, or shorted to low source. Low signal voltage detected at the aftertreatment diesel particulate filter outlet pressure sensor circuit.	Possible reduced engine performance.
3135 3610 2	Aftertreatment diesel particulate filter outlet pressure - Data erratic, intermittent or incorrect. The aftertreatment diesel particulate filter outlet pressure sensor is reading an erratic value at initial key ON or during engine operation.	Possible reduced engine performance.
3146 4363 3	Aftertreatment SCR outlet temperature sensor circuit - Voltage above normal or shorted to high source. High signal voltage detected at the SCR outlet temperature sensor circuit.	Possible reduced engine performance.
3147 4363 4	Aftertreatment SCR outlet temperature sensor circuit - Voltage below normal or shorted to low source. Low signal voltage detected at the SCR outlet temperature sensor circuit.	Possible reduced engine performance.
3148 4363 2	Aftertreatment SCR outlet temperature sensor - Data erratic, intermittent, or incorrect. The SCR outlet temperature sensor is not changing with engine operating conditions.	Possible reduced engine performance.
3151 4794 31	Aftertreatment SCR catalyst system missing - Condition exists. The aftertreatment SCR catalyst in the exhaust system is not present.	Possible reduced engine performance.

※ Some fault codes are not applied to this machine.



Fault code J1939 SPN J1939 FMI	Reason	Effect (only when fault code is active)
3165 4363 0	Aftertreatment SCR outlet temperature - Data valid but above normal operational range - Most severe level. The SCR outlet temperature sensor reading has exceeded the maximum engine protection temperature limit.	Possible reduced engine performance.
3168 3936 16	Aftertreatment diesel particulate filter system - Data valid but above normal operating range - Moderately severe level. The system has detected a malfunction in the filtering capability of the aftertreatment diesel particulate filter.	None on performance.
3186 1623 9	Tachograph output shaft speed - Abnormal update rate. No communication or an invalid data transfer rate has been detected on the J1939 data link between the ECM and the tachograph output shaft speed sensor.	None on performance.
3213 1623 19	Tachograph output shaft speed - Received network data in error. The J1939 multiplexing controller has indicated a malfunction of the tachograph output shaft speed sensor.	None on performance.
3228 3216 2	Aftertreatment Intake NOx sensor - Data erratic, intermittent, or incorrect. An incorrect NOx sensor reading has been detected by the aftertreatment intake NOx sensor.	Possible reduced engine performance.
3232 3216 9	Aftertreatment Intake NOx sensor - Abnormal update rate. No communication or an invalid data transfer rate has been detected on the J1939 data link between the ECM and the aftertreatment intake NOx sensor.	Possible reduced engine performance.
3235 4363 16	Aftertreatment SCR outlet temperature - Data valid but above normal operating range - Moderately severe level. The SCR outlet temperature sensor reading has exceeded the maximum temperature limit.	Possible reduced engine performance.
3237 4340 3	Aftertreatment diesel exhaust fluid line heater 1 circuit - Voltage above normal or shorted to high source. High signal voltage detected at the diesel exhaust fluid line heater 1 circuit.	Possible reduced engine performance.
3238 4340 4	Aftertreatment diesel exhaust fluid line heater 1 circuit - Voltage below normal, or shorted to low source. Low signal voltage detected at the diesel exhaust fluid line heater 1 circuit.	Possible reduced engine performance.
3239 4342 3	Aftertreatment diesel exhaust fluid line heater 2 circuit - Voltage above normal or shorted to high source. High signal voltage detected at the diesel exhaust fluid line heater 2 circuit.	Possible reduced engine performance.
3241 4342 4	Aftertreatment diesel exhaust fluid line heater 2 circuit - Voltage below normal, or shorted to low source. Low signal voltage detected at the diesel exhaust fluid line heater 2 circuit.	Possible reduced engine performance.

※ Some fault codes are not applied to this machine.



Fault code J1939 SPN J1939 FMI	Reason	Effect (only when fault code is active)
3242 3363 7	Aftertreatment diesel exhaust fluid tank heater - Mechanical system not responding or out of adjustment. The aftertreatment diesel exhaust fluid temperature did not increase when the aftertreatment diesel exhaust fluid tank heater was commanded ON.	Possible reduced engine performance.
3243 3060 18	Engine cooling system monitor - Data valid but below normal operating range - Moderately severe level. The engine is not warming up as expected.	None on performance.
3251 4765 16	Aftertreatment diesel oxidation catalyst intake temperature - Data valid but above normal operating range - Moderately severe level. The diesel oxidation catalyst intake temperature sensor reading has exceeded the maximum temperature limit.	Progressive power and/or speed derate increasing in severity from time of alert. If the Engine protection shutdown feature is enabled, the engine will shut down 30 seconds after the red STOP lamps starts flashing.
3253 3242 16	Aftertreatment diesel particulate filter intake temperature - Data valid but above normal operating range - Moderately severe level. The aftertreatment diesel particulate filter intake temperature sensor reading has exceeded the maximum engine protection temperature limit.	Progressive power and/or speed derate increasing in severity from time of alert. If the Engine protection shutdown feature is enabled, the engine will shut down 30 seconds after the red STOP lamps starts flashing.
3254 3242 15	Aftertreatment diesel particulate filter intake temperature - Data valid but above normal operating range - Least severe level. The aftertreatment diesel particulate filter intake temperature sensor reading has exceeded the maximum engine protection temperature limit.	Possible reduced engine performance.
3255 3246 16	Aftertreatment diesel particulate filter outlet temperature - Data valid but above normal operating range - Moderately severe level. The aftertreatment diesel particulate filter outlet temperature sensor reading has exceeded the maximum engine protection temperature limit.	Progressive power and/or speed derate increasing in severity from time of alert. If the engine protection shutdown feature is enabled, the engine will shut down 30 seconds after the red STOP lamps starts flashing.
3256 3246 15	Aftertreatment diesel particulate filter outlet temperature - Data valid but above normal operating range - Least severe level. The aftertreatment diesel particulate filter outlet temperature sensor reading has exceeded the maximum engine protection temperature limit.	Possible reduced engine performance.
3258 4340 5	Aftertreatment diesel exhaust fluid line heater 1 circuit - Current below normal or open circuit. Open circuit detected in the diesel exhaust fluid line heater 1.	Possible reduced engine performance.
3261 4342 5	Aftertreatment diesel exhaust fluid line heater 2 circuit - Current below normal or open circuit. Open circuit detected in the diesel exhaust fluid line heater 2.	Possible reduced engine performance.

※ Some fault codes are not applied to this machine.

Fault code J1939 SPN J1939 FMI	Reason	Effect (only when fault code is active)
3311 3242 0	Aftertreatment diesel particulate filter intake temperature - Data valid but above normal operating range - Most severe level. The aftertreatment diesel particulate filter intake temperature sensor reading has exceeded the maximum engine protection temperature limit.	Progressive power and/or speed derate increasing in severity from time of alert. If the engine protection shutdown feature is enabled, the engine will shut down 30 seconds after the red STOP lamps starts flashing.
3312 3246 0	Aftertreatment diesel particulate filter outlet temperature - Data valid but above normal operating range - Most severe level. The aftertreatment diesel particulate filter outlet temperature sensor reading has exceeded the maximum engine protection temperature limit.	Progressive power and/or speed derate increasing in severity from time of alert. If the engine protection shutdown feature is enabled, the engine will shut down 30 seconds after the red STOP lamps starts flashing.
3313 4765 4	Aftertreatment diesel oxidation catalyst intake temperature sensor circuit - Voltage below normal or shorted to low source. Low signal voltage detected at the catalyst intake sensor circuit.	Possible reduced engine performance.
3314 4765 3	Aftertreatment diesel oxidation catalyst intake temperature sensor circuit - Voltage above normal or shorted to high source. High signal voltage detected at the catalyst intake temperature sensor circuit.	Possible reduced engine performance.
3315 4765 2	Aftertreatment diesel oxidation catalyst intake temperature - Data erratic, intermittent, or incorrect. The aftertreatment diesel oxidation catalyst intake temperature sensor is not changing with engine operating conditions.	Possible reduced engine performance.
3316 3242 4	Aftertreatment diesel particulate filter intake temperature sensor circuit - Voltage below normal or shorted to low source. Low signal voltage detected at the aftertreatment diesel particulate filter intake temperature sensor circuit.	Possible reduced engine performance.
3317 3242 3	Aftertreatment diesel particulate filter intake temperature sensor circuit - Voltage above normal or shorted to high source. High signal voltage or open circuit detected at the aftertreatment diesel particulate filter intake temperature sensor circuit.	Possible reduced engine performance.
3318 3242 2	Aftertreatment diesel particulate filter intake temperature - Data erratic, intermittent, or incorrect. The aftertreatment diesel particulate filter intake temperature is not changing with engine operating conditions.	Possible reduced engine performance.
3319 3246 3	Aftertreatment diesel particulate filter outlet temperature sensor circuit - Voltage above normal or shorted to high source. High signal voltage or open circuit detected at the aftertreatment diesel particulate filter outlet temperature sensor circuit.	Possible reduced engine performance.

※ Some fault codes are not applied to this machine.

Fault code J1939 SPN J1939 FMI	Reason	Effect (only when fault code is active)
3321 3246 4	Aftertreatment diesel particulate filter outlet temperature sensor circuit - Voltage below normal or shorted to low source. Low signal voltage detected at the aftertreatment diesel particulate filter outlet temperature sensor circuit.	Possible reduced engine performance.
3322 3246 2	Aftertreatment diesel particulate filter outlet temperature - Data erratic, intermittent, or incorrect. The aftertreatment diesel particulate filter outlet temperature is not changing with engine operating conditions.	Possible reduced engine performance.
3326 91 9	SAE J1939 Multiplexed accelerator pedal or lever sensor system - Abnormal update rate. The ECM expected information from a multiplexed accelerator pedal or lever sensor but did not receive it soon enough or did not receive it at all.	Engine will only idle.
3328 191 9	Transmission output shaft speed - Abnormal update rate. No communication or an invalid data transfer rate has been detected on the J1939 data link between the ECM and the transmission output shaft speed sensor.	None on performance.
3342 4752 18	Engine exhaust gas recirculation cooler efficiency - Data valid but below normal operating range - Moderately severe level. The EGR cooler is not cooling the recirculated exhaust gas sufficiently.	None on performance.
3343 5285 18	Engine charge-air cooler efficiency - Data valid but below normal operating range - Moderately severe level. The engine charge air cooler is not cooling the intake air flow sufficiently.	None on performance.
3361 102 10	Intake manifold 1 pressure - Abnormal rate of change. The VGT position reading is stuck.	Possible reduced engine performance.
3366 111 18	Coolant level - Data valid but below normal operating range - Moderately severe level. Very low engine coolant level detected.	None on performance.
3374 1818 31	Roll over protection brake control active - Condition exists. The ECM received a message from the anti-lock braking (ABS) controller, inhibiting cruise control operation.	Cruise control could possibly not operate.
3375 5397 31	Aftertreatment diesel particulate filter regeneration too frequent - Condition exists. The system has detected the need for an active regeneration has occurred too soon following the last active regeneration.	None on performance.
3376 5319 31	Aftertreatment diesel particulate filter incomplete regeneration - Condition exists. The system has detected that the aftertreatment diesel particulate filter differential pressure is too high following an active regeneration.	Possible frequent need for aftertreatment regeneration.

※ Some fault codes are not applied to this machine.

Fault code J1939 SPN J1939 FMI	Reason	Effect (only when fault code is active)
3382 3058 18	Engine exhaust gas recirculation (EGR) system - Data valid but below normal operating range - Moderately severe level. Measured egr flow is lower than commanded.	Possible reduced engine performance.
3383 3058 16	Engine exhaust gas recirculation (EGR) system - Data valid but above normal operating range - Moderately severe Level. Measured EGR flow is higher than commanded.	Possible reduced engine performance.
3394 4766 18	Aftertreatment 1 diesel oxidation catalyst outlet gas temperature - Data valid but below normal operating range - Moderately severe level. The diesel oxidation catalyst outlet Temperature is below the operating limit	Possible frequent need for aftertreatment regeneration.
3396 3750 31	Diesel particulate filter 1 conditions not met for active regeneration - Condition exists. The aftertreatment temperatures are not warm enough for aftertreatment injection.	Possible frequent need for aftertreatment regeneration.
3418 191 19	Transmission output shaft speed - Received network data in error. The J1939 multiplexing controller has indicated a malfunction of the transmission output shaft speed sensor.	None on performance.
3422 4344 3	Aftertreatment diesel exhaust fluid line heater 3 circuit - Voltage above normal or shorted to high source. High signal voltage detected at the diesel exhaust fluid line heater 3 circuit.	Possible reduced engine performance.
3423 4344 4	Aftertreatment diesel exhaust fluid line heater 3 circuit - Voltage below normal, or shorted to low source. Low signal voltage detected at the diesel exhaust fluid line heater 3 circuit.	Possible reduced engine performance.
3425 4344 5	Aftertreatment diesel exhaust fluid line heater 3 circuit - Current below normal or open circuit. Open circuit detected in the diesel exhaust fluid line heater 3.	Possible reduced engine performance.
3488 563 9	Anti-lock braking (ABS) controller - Abnormal update rate. No communication or an invalid data transfer rate has been detected on the J1939 data link between the ECM and the anti-lock braking (ABS) controller.	None on performance.
3492 251 10	Real time clock - Abnormal rate of change. The real time clock indicates a stuck engine off timer.	None on performance.
3494 1081 7	Engine wait to start lamp - Mechanical system not responding or out of adjustment. Wait to Start lamp has malfunction.	None on performance.
3497 1761 17	Aftertreatment diesel exhaust fluid tank level - Data valid but below normal operating range - Least severe level. The aftertreatment diesel exhaust fluid tank level is low.	None on performance.

※ Some fault codes are not applied to this machine.

Fault code J1939 SPN J1939 FMI	Reason	Effect (only when fault code is active)
3498 1761 18	Aftertreatment diesel exhaust fluid tank level - Data valid but below normal operating range - Moderately severe level. The aftertreatment diesel exhaust fluid tank level is very low.	None on performance.
3525 84 19	Wheel-based vehicle speed - Received network data in error. The J1939 multiplexing controller has indicated a malfunction of the wheel-based vehicle speed sensor.	Engine speed limited to maximum engine speed without VSS parameter value. Cruise control, gear-down protection, and road speed governor will not work.
3526 84 9	Wheel-Based vehicle speed - Abnormal update rate. No communication or an invalid data transfer rate has been detected on the J1939 data link between the ECM and the wheel-based vehicle speed sensor.	Engine speed limited to maximum engine speed without VSS parameter value. Cruise control, gear-down protection, and road speed governor will not work.
3527 558 19	Accelerator pedal or lever idle validation switch - Received network data in error. The J1939 multiplexing controller has indicated a malfunction of the accelerator pedal or lever idle validation switch.	The engine will only idle.
3528 558 9	Accelerator pedal or lever idle validation switch - Abnormal update rate. No communication or an invalid data transfer rate has been detected on the J1939 data link between the ECM and the accelerator pedal or lever idle validation switch.	Engine will only idle.
3531 171 9	Ambient air temperature - Abnormal update rate. No communication or an invalid data transfer rate has been detected on the J1939 data link between the ECM and the ambient air temperature sensor.	Possible reduced engine performance.
3532 171 19	Ambient air temperature - Received network data in error. The J1939 multiplexing controller has indicated a malfunction of the ambient air temperature sensor.	Possible reduced engine performance.
3539 51 3	Engine intake throttle actuator position sensor circuit - Voltage above normal, or shorted to high source. High signal voltage detected at the engine intake air throttle position sensor circuit.	Possible reduced engine performance.
3541 51 4	Engine intake throttle actuator position sensor circuit - Voltage below normal, or shorted to low source. Low signal voltage detected at the engine intake air throttle position sensor circuit.	Possible reduced engine performance.
3542 51 2	Engine intake throttle actuator position sensor - Data erratic, intermittent or incorrect. The engine intake air throttle position feedback is erratic or incorrect.	Possible reduced engine performance.
3545 3226 10	Aftertreatment outlet NOx sensor circuit - Abnormal rate of change. The aftertreatment outlet NOx sensor reading is not valid.	None on performance.

※ Some fault codes are not applied to this machine.

Fault code J1939 SPN J1939 FMI	Reason	Effect (only when fault code is active)
3547 4096 31	Aftertreatment diesel exhaust fluid tank empty - Condition exists. The diesel exhaust fluid tank is empty.	Possible reduced engine performance.
3555 1081 9	Engine wait to start lamp - Abnormal update rate. A loss of communication has been detected.	None on performance.
3556 1081 19	Engine wait to start lamp - Received network data in error. The ECM received an invalid signal on the SAE J1939 datalink.	None on performance.
3558 3361 3	Aftertreatment diesel exhaust fluid dosing unit - Voltage above normal or shorted to high source. High signal voltage detected at the aftertreatment diesel exhaust fluid dosing unit.	Possible reduced engine performance.
3559 3361 4	Aftertreatment diesel exhaust fluid dosing unit - Voltage below normal or shorted to low source. Low signal voltage detected at the aftertreatment diesel exhaust fluid dosing unit.	Possible reduced engine performance.
3562 5491 3	Aftertreatment diesel exhaust fluid line heater relay - Voltage above normal or shorted to high source. High signal voltage detected at the diesel exhaust fluid line heater relay.	Possible reduced engine performance.
3563 5491 4	Aftertreatment diesel exhaust fluid line heater relay - Voltage below normal or shorted to low source. Low signal voltage detected at the diesel exhaust fluid line heater relay.	Possible reduced engine performance.
3567 5394 5	Aftertreatment diesel exhaust fluid dosing valve - Current below normal or open circuit. A circuit error has been detected in the aftertreatment diesel exhaust fluid dosing valve circuit.	Possible reduced engine performance.
3568 5394 7	Aftertreatment diesel exhaust fluid (DEF) Dosing valve - Mechanical system not responding or out of adjustment. A mechanical malfunction has been detected in the DEF dosing valve.	Possible reduced engine performance.
3571 4334 3	Aftertreatment diesel exhaust fluid pressure sensor - Voltage above normal or shorted to high source. High signal voltage detected at the aftertreatment diesel exhaust fluid pressure sensor circuit.	Possible reduced engine performance.
3572 4334 4	Aftertreatment diesel exhaust fluid pressure sensor - Voltage below normal or shorted to low source. Low signal voltage detected at the diesel exhaust fluid pressure sensor circuit.	Possible reduced engine performance.
3574 4334 18	Aftertreatment diesel exhaust fluid pressure sensor - Data valid but below normal operating range - Moderately severe level. Low diesel exhaust fluid pressure has been detected in the dosing unit.	Possible reduced engine performance.

※ Some fault codes are not applied to this machine.

Fault code J1939 SPN J1939 FMI	Reason	Effect (only when fault code is active)
3575 4334 16	Aftertreatment diesel exhaust fluid pressure sensor - Data valid but above normal operating range - Moderately severe level. The diesel exhaust fluid dosing unit has detected a blockage in the diesel exhaust fluid return flow.	Possible reduced engine performance.
3577 4376 3	Aftertreatment diesel exhaust fluid return valve - Voltage above normal or shorted to high source. High signal voltage detected at the aftertreatment diesel exhaust fluid return valve.	Possible reduced engine performance.
3578 4376 4	Aftertreatment diesel exhaust fluid return valve - Voltage below normal, or shorted to low source. Low signal voltage detected at the diesel exhaust fluid return valve.	Possible reduced engine performance.
3582 4364 18	Aftertreatment SCR catalyst conversion efficiency - Data valid but below normal operating range - Moderately severe level. NOx conversion across the SCR catalyst is too low.	Possible reduced engine performance.
3583 5031 10	Aftertreatment outlet NOx sensor heater - Abnormal rate of change. The aftertreatment outlet NOx sensor heater is unable to maintain its normal operating temperature.	None on performance.
3596 4334 2	Aftertreatment diesel exhaust fluid pressure sensor - Data erratic, intermittent, or incorrect. The diesel exhaust fluid pressure sensor has reported a reading too high or low for the operating conditions.	Possible reduced engine performance.
3649 5024 10	Aftertreatment Intake NOx sensor heater - Abnormal rate of change. The aftertreatment intake NOx sensor heater is unable to maintain its normal operating temperature.	None on performance.
3681 3228 2	Aftertreatment outlet NOx sensor power supply - Data erratic, intermittent, or incorrect. The aftertreatment outlet NOx sensor indicates that the power supply to the sensor is incorrect.	None on performance.
3682 3218 2	Aftertreatment Intake NOx sensor power supply - Data erratic, entermittent or encorrect. The aftertreatment intake NOx sensor indicates that the power supply to the sensor is incorrect.	None on performance.
3697 630 12	Engine control module calibration memory - Bad intelligent device or component. Error internal to the ECM related to engine software failures.	Engine may not start or may be difficult to start.
3712 5246 0	Aftertreatment SCR operator inducement - Data valid but above normal operational range - Most severe level. Critical SCR related fault codes have been active for an extended period of time and require immediate attention.	Vehicle speed will be limited to 8 km [5 miles] per hour.

※ Some fault codes are not applied to this machine.



Fault code J1939 SPN J1939 FMI	Reason	Effect (only when fault code is active)
3714 1569 31	Engine protection torque derate - Condition exists. Critical fault codes related to engine operation are active.	Possible reduced engine performance.
3715 188 16	Engine speed at idle - Data valid but below normal operating range - Moderately severe level. The engine speed at idle has exceeded the governed idle speed.	Possible reduced engine performance.
3716 188 18	Engine speed at idle - Data valid but below normal operational range - Moderately severe level. Engine is not maintaining the governed idle speed.	None on performance.
3717 3226 13	Aftertreatment outlet NOx sensor - Out of calibration. A calibration mismatch between the aftertreatment outlet NOx sensor and the ECM has been detected.	None on performance.
3718 3216 13	Aftertreatment intake NOx - Out of calibration. A calibration mismatch between the aftertreatment intake NOx sensor and the ECM has been detected.	None on performance.
3724 168 17	Battery 1 voltage - Data valid but below normal operating range - Least severe level. Low voltage to the EGR valve device driver has been detected.	Possible reduced engine performance.
3725 3216 10	Aftertreatment Intake NOx sensor - Abnormal rate of change. The aftertreatment intake NOx sensor reading is not valid.	None on performance.
3727 5571 7	High pressure common rail fuel pressure relief valve - Mechanical system not responding or out of adjustment. The fuel rail high-pressure relief valve has opened at a lower than expected pressure.	Possible reduced engine performance.
3737 1675 31	Engine starter mode overcrank protection - Condition exists. The starter motor has been temporarily disabled in order to prevent starter damage.	Starter operation is prohibited until the starter motor has adequately cooled.
3741 5571 0	High pressure common rail fuel pressure relief valve - Data valid but above normal operational range - Most severe level. The fuel rail pressure relief valve has opened due to high fuel rail pressure.	Engine may run rough, may stop running, may not start, or may be difficult to start.
3749 3226 20	Aftertreatment outlet NOx sensor - Data not rational - Drifted high. An offset in the outlet NOx sensor reading has been detected.	None on performance.
3838 2978 9	Estimated engine parasitic losses - Percent torque - Abnormal update rate. A loss of communication has been detected.	None on performance.
3843 5603 9	Cruise control disable command - Abnormal update rate. No communication or an invalid data transfer rate has been detected on the J1939 data link between the ECM and the cruise control.	None on performance.

※ Some fault codes are not applied to this machine.



Fault code J1939 SPN J1939 FMI	Reason	Effect (only when fault code is active)
3844 5605 31	Cruise control pause command - Condition exists. The adaptive cruise control has dropped out and must be manually engaged.	Cruise control could possibly not operate.
3845 5603 31	Cruise control disable command - Condition exists. The adaptive cruise control has dropped out and must be manually engaged.	Cruise control could possibly not operate.
3899 5848 4	Aftertreatment 1 SCR Intermediate NH3 sensor - Voltage below normal, or shorted to low source. A circuit error has been detected in the NH3 sensor.	None on performance.
3911 5848 9	Aftertreatment SCR Intermediate NH3 sensor - Abnormal update rate. Loss of communication with the aftertreatment SCR intermediate NH3 sensor.	Possible reduced engine performance.
3912 5853 10	Aftertreatment SCR Intermediate NH3 sensor heater - Abnormal rate of change. A malfunction of the aftertreatment SCR intermediate NH3 sensor heater has been detected.	Possible reduced engine performance.
3932 5851 16	Aftertreatment SCR Intermediate NH3 gas sensor power supply - Data valid but above normal operating range - Moderately severe level. High battery voltage supply detected at the aftertreatment SCR intermediate NH3 sensor.	Possible reduced engine performance.
3933 5851 18	Aftertreatment SCR Intermediate NH3 gas sensor power supply - Data valid but below normal operating range - Moderately severe level. Low battery voltage supply detected at the aftertreatment SCR intermediate NH3 sensor.	Possible reduced engine performance.
3934 5851 2	Aftertreatment SCR Intermediate NH3 gas sensor power supply - Data erratic, intermittent or incorrect. Intermittent battery voltage supply detected at the aftertreatment SCR intermediate NH3 sensor.	Possible reduced engine performance.
3935 5848 13	Aftertreatment SCR Intermediate NH3 sensor - Out of calibration. Incorrect trim resistance has been detected in the aftertreatment SCR intermediate NH3 sensor.	Possible reduced engine performance.
3936 5848 12	Aftertreatment SCR Intermediate NH3 sensor - Bad intelligent device or component. An internal error of the aftertreatment SCR intermediate NH3 sensor has been detected.	Possible reduced engine performance.
3937 5848 10	Aftertreatment 1 SCR Intermediate NH3 sensor - Abnormal rate of change. The aftertreatment SCR intermediate NH3 sensor reading is NOT valid.	Possible reduced engine performance.

※ Some fault codes are not applied to this machine.

Fault code J1939 SPN J1939 FMI	Reason	Effect (only when fault code is active)
4149 2623 8	Accelerator pedal or lever position sensor 2 circuit frequency - Abnormal frequency or pulse width or period. The accelerator pedal position sensor reading is out of range.	The engine will operate in Limp Home mode.
4151 5742 9	Aftertreatment diesel particulate filter temperature sensor module - Abnormal update rate. No communications on the J1939 data link between the ECM and the aftertreatment diesel particulate filter temperature sensor module.	Possible reduced engine performance.
4152 5743 9	Aftertreatment selective catalytic reduction temperature sensor module - Abnormal update rate. No communications on the J1939 data link between the ECM and the aftertreatment SCR temperature sensor module.	Possible reduced engine performance.
4155 5746 3	Aftertreatment 1 diesel exhaust fluid dosing unit heater relay - Voltage above normal, or shorted to high source. High signal voltage detected at the aftertreatment diesel exhaust fluid dosing unit heater relay circuit.	Possible reduced engine performance.
4156 5746 4	Aftertreatment 1 diesel exhaust fluid dosing unit heater relay - Voltage below normal, or shorted to low source. Low signal voltage detected at the aftertreatment diesel exhaust fluid dosing unit heater relay circuit.	Possible reduced engine performance.
4157 4376 7	Aftertreatment diesel exhaust fluid return valve - Mechanical system not responding or out of adjustment. A stuck aftertreatment diesel exhaust fluid return valve has been detected.	None on performance.
4158 5742 12	Aftertreatment diesel particulate filter temperature sensor module - Bad intelligent device or component. An internal error has been detected in the aftertreatment diesel particulate filter temperature sensor module.	Possible reduced engine performance.
4159 5743 12	Aftertreatment selective catalytic reduction temperature sensor module - Bad intelligent device or component. An internal error has been detected in the aftertreatment SCR temperature sensor module.	Possible reduced engine performance.
4161 5742 3	Aftertreatment diesel particulate filter temperature sensor module - Voltage above normal, or shorted to high source. High battery supply voltage detected at the aftertreatment diesel particulate filter temperature sensor module.	Possible reduced engine performance.
4162 5742 4	Aftertreatment diesel particulate filter temperature sensor module - Voltage below normal, or shorted to low source. Low battery supply voltage detected at the aftertreatment diesel particulate filter temperature sensor module.	Possible reduced engine performance.

※ Some fault codes are not applied to this machine.

Fault code J1939 SPN J1939 FMI	Reason	Effect (only when fault code is active)
4163 5742 16	Aftertreatment diesel particulate filter temperature sensor module- Data valid but above normal operating range - Moderately severe level. High internal temperature detected in the aftertreatment diesel particulate filter temperature sensor module.	Possible reduced engine performance.
4164 5743 3	Aftertreatment selective catalytic reduction temperature sensor module - Voltage above normal, or shorted to high source. High battery supply voltage detected at the aftertreatment SCR temperature sensor module.	Possible reduced engine performance.
4165 5743 4	Aftertreatment selective catalytic reduction temperature sensor module - Voltage below normal, or shorted to low source. Low battery supply voltage detected at the aftertreatment SCR temperature sensor module.	Possible reduced engine performance.
4166 5743 16	Aftertreatment selective catalytic reduction temperature sensor module - Data valid but above normal operating range - Moderately severe level. High internal temperature detected in the aftertreatment SCR temperature sensor module.	Possible reduced engine performance.
4168 5745 3	Aftertreatment diesel exhaust fluid dosing unit heater - Voltage above normal, or shorted to high source. The aftertreatment diesel exhaust fluid dosing unit heater is detected to be stuck on.	None on performance.
4169 5745 5	Aftertreatment diesel exhaust fluid dosing unit heater - Voltage below normal, or shorted to low source. The aftertreatment diesel exhaust fluid dosing unit heater is detected to be stuck off.	Possible reduced engine performance.
4171 5745 18	Aftertreatment diesel exhaust fluid dosing unit heater - Data valid but below normal operating range - Moderately severe level. The aftertreatment diesel exhaust fluid dosing unit failed to thaw.	Possible reduced engine performance.
4213 3695 2	Aftertreatment diesel particulate filter regeneration inhibit switch - Data erratic, intermittent or incorrect. The diesel particulate filter regeneration permit switch is stuck in the OFF or INHIBIT position.	Possible frequent need for aftertreatment regeneration.
4215 563 31	Anti-lock braking (ABS) Active - Condition exists. Cruise control was paused due to an anti-wheel slip message from the ABS controller.	Adaptive cruise control will not operate. Standard cruise control may not operate.
4244 4337 2	Aftertreatment diesel exhaust fluid dosing temperature - Data erratic, intermittent or incorrect. The aftertreatment diesel exhaust fluid dosing temperature is irrational.	None on performance.

※ Some fault codes are not applied to this machine.

Fault code J1939 SPN J1939 FMI	Reason	Effect (only when fault code is active)
4245 5798 2	Aftertreatment diesel exhaust fluid dosing unit heater temperature - Data erratic, intermittent or incorrect. The aftertreatment diesel exhaust fluid dosing unit heater temperature is irrational.	None on performance.
4249 4337 10	Aftertreatment diesel exhaust fluid dosing temperature - Abnormal rate of change. The aftertreatment diesel exhaust fluid dosing unit temperature is stuck.	None on performance.
4251 5798 10	Aftertreatment 1 diesel exhaust fluid dosing unit heater temperature - Abnormal rate of change. The aftertreatment diesel exhaust fluid dosing unit heater temperature sensor reading is stuck.	None on performance.
4252 1081 31	Engine wait to start lamp - Condition exists. The received signal does not match the commanded signal.	None on performance.
4259 5742 11	Aftertreatment diesel particulate filter temperature sensor module - Root cause not known. Intermittent battery voltage supply detected at the aftertreatment diesel particulate filter temperature sensor module.	Possible reduced engine performance.
4261 5743 11	Aftertreatment selective catalytic reduction temperature sensor module - Root cause not known. Intermittent battery voltage supply detected at the aftertreatment SCR temperature sensor module.	Possible reduced engine performance.
4279 5848 21	Aftertreatment 1 SCR Intermediate NH3 - Data not rational - Drifted low. An in range low failure has been detected.	Possible reduced engine performance.
4281 5848 2	Aftertreatment SCR Intermediate NH3 - Data erratic, intermittent or incorrect. The aftertreatment SCR intermediate NH3 sensor reading is stuck.	None on performance.
4284 5793 9	Desired engine fueling state - Abnormal update rate. A valid message from the transmission ECU has NOT been received.	Engine may not start or may be difficult to start.
4289 91 8	Accelerator pedal or lever position sensor 1 circuit frequency - Abnormal frequency or pulse width or period. The accelerator pedal position sensor reading is out of range.	The engine will operate in limp home mode.
4452 520668 31	Aftertreatment outlet NOx sensor closed loop operation - Condition exists. The maximum dosing adjustment has been reached.	Possible reduced engine performance.
4453 520669 31	Aftertreatment intermediate NH3 sensor closed loop operation - Condition exists. The maximum dosing adjustment has been reached.	None on performance.
4517 237 13	Vehicle Identification number - Out of calibration. The vehicle identification number has not been programmed into the ECM.	None on performance.

※ Some fault codes are not applied to this machine.

Fault code J1939 SPN J1939 FMI	Reason	Effect (only when fault code is active)
4518 5862 3	Aftertreatment SCR Intermediate gas temperature sensor circuit - Voltage above normal, or shorted to high source. High signal voltage detected at the aftreatment SCR intermediate temperature sensor circuit.	Possible reduced engine performance.
4519 5862 4	Aftertreatment SCR Intermediate gas temperature sensor circuit - Voltage below normal, or shorted to low source. Low signal voltage detected at the aftertreatment SCR intermediate temperature sensor circuit.	Possible reduced engine performance.
4521 5862 2	Aftertreatment SCR Intermediate gas temperature sensor - Data erratic, intermittent or incorrect. The aftertreatment SCR intermediate temperature sensor reading is irrational.	Possible reduced engine performance.
4524 5862 0	Aftertreatment SCR intermediate gas temperature - Data valid but above normal operational range - Most severe level. The aftertreatment SCR intermediate temperature sensor reading is above the engine protection limit.	Progressive power and/or speed derate increasing in severity from time of alert. If the engine protection shutdown feature is enabled, the engine will shut down 30 seconds after the red STOP lamps starts flashing.
4525 5862 16	Aftertreatment 1 SCR intermediate gas temperature - Data valid but above normal operating range - Moderately severe level. High SCR Intermediate temperature detected.	Progressive power and/or speed derate increasing in severity from time of alert. If the engine protection shutdown feature is enabled, the engine will shut down 30 seconds after the red STOP lamps starts flashing.
4526 521 2	Brake pedal position - Data erratic, intermittent or incorrect. The values of the 2 brake switch signals do not match.	None on performance.
4572 3031 9	Aftertreatment diesel exhaust fluid tank temperature - Abnormal update rate. The ECM lost communication with the aftertreatment diesel exhaust fluid tank temperature sensor.	Possible reduced engine performance.
4584 3936 14	Aftertreatment diesel particulate filter system - Special instructions. The incorrect aftertreatment diesel particulate filter system has been installed with the engine.	Engine will be shut down.
4585 4792 14	Aftertreatment 1 SCR catalyst system - Special instructions. The incorrect SCR system has been Installed.	Engine will be shut down.
4612 520701 31	Engine intake manifold pressure system monitor - Condition exists. The engine is unable to meet the air handling system commands.	Possible reduced engine performance.
4658 4331 18	Aftertreatment SCR actual dosing reagent quantity - Data valid but below normal operating range - Moderately severe level. Low aftertreatment diesel exhaust fluid flow detected.	Possible reduced engine performance.

※ Some fault codes are not applied to this machine.

Fault code J1939 SPN J1939 FMI	Reason	Effect (only when fault code is active)
4691 5585 18	Engine injector metering rail 1 cranking pressure - Data valid but below normal operating range - Moderately severe level. The fuel rail pressure during cranking is too low for the engine to start.	Engine may not start or may be difficult to start.
4713 5357 31	Engine fuel injection quantity error for multiple cylinders - Condition exists. A malfunction of all fuel injectors has been detected.	Engine may run rough, may stop running, may not start, or may be difficult to start.
4726 1239 16	Engine fuel leakage - Data valid but above normal operating range - Moderately severe level. Fuel rail pressure decay has been detected.	Engine may run rough, may stop running, may not start, or may be difficult to start.
4727 157 15	Injector metering rail 1 pressure - Data valid but above normal operating range - Least severe level. A self pumping condition has been detected in the fuel system.	Possible reduced engine performance.
4731 3031 13	Aftertreatment diesel exhaust fluid tank temperature sensor - Out of calibration. The received datalink message was not valid.	Possible reduced engine performance.
4732 1761 13	Aftertreatment diesel exhaust fluid tank level sensor - Out of calibration. The received datalink message was not valid.	None on performance.
4739 1761 11	Aftertreatment 1 diesel exhaust fluid tank level sensor - Root cause not known. An unknown error has been detected with the aftertreatment diesel exhaust fluid tank level sensor.	Possible reduced engine performance.
4769 1761 10	Aftertreatment 1 diesel exhaust fluid tank level sensor - Abnormal rate of change. A valid diesel exhaust fluid tank level reading has NOT been received.	Possible reduced engine performance.
4865 6303 3	Engine coolant level 2 sensor circuit - Voltage above normal, or shorted to high source. High signal voltage detected at the engine coolant level 2 circuit.	None on performance.
4866 6303 4	Engine coolant level 2 sensor circuit - Voltage below normal, or shorted to low source. Low signal voltage detected at the engine coolant level 2 circuit.	None on performance.
4956 520750 13	Engine variable geometry turbo (VGT) software - Out of calibration. VGT software does not match application.	Possible reduced engine performance.
4957 520750 31	Engine variable geometry turbo (VGT) software - Condition exists. The VGT actuator and ECM software is not compatible.	Possible reduced engine performance.

※ Some fault codes are not applied to this machine.

### 3) DEFINITION OF OPERATING MODES

#### (1) Normal

There's no failure detected in the transmission system or the failure has no or slight effects on transmission control. TCU will work without or in special cases with little limitations. (See following table)

#### (2) Substitute clutch control

TCU can't change the gears or the direction under the control of the normal clutch modulation. TCU uses the substitute strategy for clutch control. All modulations are only time controlled. (Comparable with EST 25)

#### (3) Limp-home

The detected failure in the system has strong limitations to transmission control. TCU can engage only one gear in each direction. In some cases only one direction will be possible.

TCU will shift the transmission into neutral at the first occurrence of the failure. First, the operator must shift the gear selector into neutral position.

If output speed is less than a threshold for neutral to gear and the operator shifts the gear selector into forward or reverse, the TCU will select the limp-home gear.

If output speed is less than a threshold for reversal speed and TCU has changed into the limp-home gear and the operator selects a shuttle shift, TCU will shift immediately into the limp-home gear of the selected direction.

If output speed is greater than the threshold, TCU will shift the transmission into neutral. The operator has to slow down the vehicle and must shift the gear selector into neutral position.

#### (4) Transmission-shutdown

TCU has detected a severe failure that disables control of the transmission.

TCU will shut off the solenoid valves for the clutches and also the common power supply (VPS1).

Transmission shifts to neutral. The park brake will operate normally, also the other functions which use ADM1 to ADM8.

The operator has to slow down the vehicle. The transmission will stay in neutral.

#### (5) TCU-shutdown

TCU has detected a severe failure that disables control of system.

TCU will shut off all solenoid valves and also both common power supplies (VPS1, VPS2). The park brake will engage, also functions are disabled which use ADM 1 to ADM 8.

The transmission will stay in neutral.

#### ※ Abbreviations

OC : Open circuit

SC : Short circuit

OP mode : Operating mode

TCU : Transmission control unit

EEC : Electronic engine controller

PTO : Power take off



#### 4) TRANSMISSION FAULT CODES

Fault code (Hex)	Meaning of the fault code possible reason for fault detection	Reaction of the TCU	Possible steps to repair
10	Logical error at direction select signal 3rd shift lever TCU detected a wrong signal combination for the direction · Cable from shift lever 3 to TCU is broken · Cable is defective and is contacted to battery voltage or vehicle ground · Shift lever is defective	TCU shifts transmission to neutral if selector active OP mode : Transmission shutdown if selector active	· Check the cables from TCU to shift lever 3 · Check signal combinations of shift lever positions F-N-R · If shift lever is a CAN shift lever check CAN cable/shifter/device ※ Fault is cleared if TCU detects a valid neutral signal for the direction at the shift lever
11	Logical error at gear range signal TCU detected a wrong signal combination for the gear range · Cable from shift lever to TCU is broken · Cable is defective and is contacted to battery voltage or vehicle ground · Shift lever is defective	TCU shifts transmission to neutral OP mode : Transmission shutdown	· Check the cables from TCU to shift lever · Check signal combinations of shift lever positions for gear range ※ Failure cannot be detected in systems with DW2/DW3 shift lever. Fault is taken back if TCU detects a valid signal for the position
12	Logical error at direction select signal TCU detected a wrong signal combination for the direction · Cable from shift lever to TCU is broken · Cable is defective and is contacted to battery voltage or vehicle ground · Shift lever is defective	TCU shifts transmission to neutral OP mode : Transmission shutdown	· Check the cables from TCU to shift lever · Check signal combinations of shift lever positions F-N-R ※ Fault is taken back if TCU detects a valid signal for the direction at the shift lever
13	Logical error at engine derating device TCU detected no reaction of engine while derating device active	After selecting neutral, TCU change to OP mode limp home	· Check engine derating device ※ This fault is reset after power up of TCU
15	Logical error at direction select signal 2 shift lever TCU detected a wrong signal combination for the direction · Cable from shift lever 2 to TCU is broken · Cable is defective and is contacted to battery voltage or vehicle ground · Shift lever is defective	TCU shifts transmission to neutral if selector active OP mode : Transmission shutdown if selector active	· Check the cables from TCU to shift lever 2 · Check signal combinations of shift lever positions F-N-R ※ Fault is taken back if TCU detects a valid neutral signal for the direction at the shift lever
17	S.C. to ground at customer specific function No. 1 (ride control) TCU detected a wrong voltage at the output pin, that looks like a S.C. to vehicle ground · Cable is defective and is contacted to vehicle ground · Customer specific function No. 1 device has an internal defect · Connector pin is contacted to vehicle ground	Customer specific	· Check the cable from TCU to customer specific function No. 1 device · Check the connectors from customer specific function No. 1 to TCU · Check the resistance of customer specific function No. 1 device

※ Some fault codes are not applied to this machine.



Fault code (Hex)	Meaning of the fault code possible reason for fault detection	Reaction of the TCU	Possible steps to repair
18	S.C. to battery voltage at customer specific function No. 1 (ride control) TCU detected a wrong voltage at the output pin, that looks like a S.C. to battery voltage <ul style="list-style-type: none"> <li>· Cable is defective and is contacted to battery voltage</li> <li>· Customer specific function No. 1 device has an internal defect</li> <li>· Connector pin is contacted to battery voltage</li> </ul>	Customer specific	<ul style="list-style-type: none"> <li>· Check the cable from TCU to customer specific function No. 1 device</li> <li>· Check the connectors from customer specific function No. 1 to TCU</li> <li>· Check the resistance of customer specific function No. 1 device</li> </ul>
19	O.C. at customer specific function No. 1 (ride control) TCU detected a wrong voltage at the output pin, that looks like a O.C. for this output pin <ul style="list-style-type: none"> <li>· Cable is defective and has no connection to TCU</li> <li>· Customer specific function No. 1 device has an internal defect</li> <li>· Connector has no connection to TCU</li> </ul>	Customer specific	<ul style="list-style-type: none"> <li>· Check the cable from TCU to customer specific function No. 1 device</li> <li>· Check the connectors from customer specific function No. 1 device to TCU</li> <li>· Check the resistance of customer specific function No. 1 device</li> </ul>
21	S.C. to battery voltage at clutch cut off input The measured voltage is too high: <ul style="list-style-type: none"> <li>· Cable is defective and is contacted to battery voltage</li> <li>· Clutch cut off sensor has an internal defect</li> <li>· Connector pin is contacted to battery voltage</li> </ul>	Clutch cut off function is disabled OP mode : Normal	<ul style="list-style-type: none"> <li>· Check the cable from TCU to the sensor</li> <li>· Check the connectors</li> <li>· Check the clutch cut off sensor</li> </ul>
22	S.C. to ground or O.C. at clutch cut off input The measured voltage is too low: <ul style="list-style-type: none"> <li>· Cable is defective and is contacted to vehicle ground</li> <li>· Cable has no connection to TCU</li> <li>· Clutch cut off sensor has an internal defect</li> <li>· Connector pin is contacted to vehicle ground or is broken</li> </ul>	Clutch cut off function is disabled OP mode : Normal	<ul style="list-style-type: none"> <li>· Check the cable from TCU to the sensor</li> <li>· Check the connectors</li> <li>· Check the clutch cut off sensor</li> </ul>
25	S.C. to battery voltage or O.C. at transmission sump temperature sensor input The measured voltage is too high: <ul style="list-style-type: none"> <li>· Cable is defective and is contacted to battery voltage</li> <li>· Cable has no connection to TCU</li> <li>· Temperature sensor has an internal defect</li> <li>· Connector pin is contacted to battery voltage or is broken</li> </ul>	No reaction, TCU use default temperature OP mode : Normal	<ul style="list-style-type: none"> <li>· Check the cable from TCU to the sensor</li> <li>· Check the connectors</li> <li>· Check the temperature sensor</li> </ul>

※ Some fault codes are not applied to this machine.

Fault code (Hex)	Meaning of the fault code possible reason for fault detection	Reaction of the TCU	Possible steps to repair
26	S.C. to battery voltage or O.C. at transmission sump temperature sensor input The measured voltage is too low: · Cable is defective and is contacted to vehicle ground · Temperature sensor has an internal defect · Connector pin is contacted to vehicle ground	No reaction, TCU uses default temperature OP mode : Normal	· Check the cable from TCU to the sensor · Check the connectors · Check the temperature sensor
27	S.C. to battery voltage or O.C. at retarder temperature sensor input The measured voltage is too high: · Cable is defective and is contacted to battery voltage · Cable has no connection to TCU · Temperature sensor has an internal defect · Connector pin is contacted to battery voltage or is broken	No reaction, TCU uses default temperature OP mode : Normal	· Check the cable from TCU to the sensor · Check the connectors · Check the temperature sensor
28	S.C. to ground at retarder temperature sensor input The measured voltage is too low: · Cable is defective and is contacted to vehicle ground · Temperature sensor has an internal defect · Connector pin is contacted to vehicle ground	No reaction, TCU uses default temperature OP mode : Normal	· Check the cable from TCU to the sensor · Check the connectors · Check the temperature sensor
31	S.C. to battery voltage or O.C. at engine speed input TCU measures a voltage higher than 7.00V at speed input pin · Cable is defective and is contacted to battery voltage · Cable has no connection to TCU · Speed sensor has an internal defect · Connector pin is contacted to battery voltage or has no contact	OP mode : Substitute clutch control	· Check the cable from TCU to the sensor · Check the connectors · Check the speed sensor
32	S.C. to ground at engine speed input TCU measures a voltage less than 0.45V at speed input pin · Cable/connector is defective and is contacted to vehicle ground · Speed sensor has an internal defect	OP mode : Substitute clutch control	· Check the cable from TCU to the sensor · Check the connectors · Check the speed sensor
33	Logical error at engine speed input TCU measures a engine speed over a threshold and the next moment the measured speed is zero · Cable/connector is defective and has bad contact · Speed sensor has an internal defect · Sensor gap has the wrong size	OP mode : Substitute clutch control	· Check the cable from TCU to the sensor · Check the connectors · Check the speed sensor · Check the sensor gap ※ This fault is reset after power up of TCU

※ Some fault codes are not applied to this machine.

Fault code (Hex)	Meaning of the fault code possible reason for fault detection	Reaction of the TCU	Possible steps to repair
34	S.C. to battery voltage or O.C. at turbine speed input TCU measures a voltage higher than 7.00V at speed input pin · Cable is defective and is contacted to vehicle battery voltage · Cable has no connection to TCU · Speed sensor has an internal defect · Connector pin is contacted to battery voltage or has no contact	OP mode : Substitute clutch control If a failure is existing at output speed, TCU shifts to neutral OP mode : Limp home	· Check the cable from TCU to the sensor · Check the connectors · Check the speed sensor
35	S.C. to ground at turbine speed input TCU measures a voltage less than 0.45V at speed input pin · Cable/connector is defective and is contacted to vehicle ground · Speed sensor has an internal defect	OP mode : Substitute clutch control If a failure is existing at output speed, TCU shifts to neutral OP mode : Limp home	· Check the cable from TCU to the sensor · Check the connectors · Check the speed sensor ※ This fault is reset after power up of TCU
36	Logical error at turbine speed input TCU measures a turbine speed over a threshold and at the next moment the measured speed is zero · Cable/connector is defective and has bad contact · Speed sensor has an internal defect · Sensor gap has the wrong size	OP mode : Substitute clutch control If a failure is existing at output speed, TCU shifts to neutral OP mode : Limp home	· Check the cable from TCU to the sensor · Check the connectors · Check the speed sensor · Check the sensor gap
37	S.C. to battery voltage or O.C. at internal speed input TCU measures a voltage higher than 7.00V at speed input pin · Cable is defective and is contacted to vehicle battery voltage · Cable has no connection to TCU · Speed sensor has an internal defect · Connector pin is contacted to battery voltage or has no contact	OP mode : Substitute clutch control	· Check the cable from TCU to the sensor · Check the connectors · Check the speed sensor
38	S.C. to ground at turbine speed input TCU measures a voltage less than 0.45V at speed input pin · Cable/connector is defective and is contacted to vehicle ground · Speed sensor has an internal defect	OP mode : Substitute clutch control	· Check the cable from TCU to the sensor · Check the connectors · Check the speed sensor
39	Logical error at internal speed input TCU measures a internal speed over a threshold and at the next moment the measured speed is zero · Cable/connector is defective and has bad contact · Speed sensor has an internal defect · Sensor gap has the wrong size	OP mode : Substitute clutch control	· Check the cable from TCU to the sensor · Check the connectors · Check the speed sensor · Check the sensor gap ※ This fault is reset after power up of TCU
3A	S.C. to battery voltage or O.C. at output speed input TCU measures a voltage higher than 12.5V at speed input pin · Cable is defective and is contacted to battery voltage · Cable has no connection to TCU · Speed sensor has an internal defect · Connector pin is contacted to battery voltage or has no contact	Special mode for gear selection OP mode : Substitute clutch control If a failure is existing at turbine speed, TCU shifts to neutral OP mode : Limp home	· Check the cable from TCU to the sensor · Check the connectors · Check the speed sensor

※ Some fault codes are not applied to this machine.

Fault code (Hex)	Meaning of the fault code possible reason for fault detection	Reaction of the TCU	Possible steps to repair
3B	S.C. to ground at output speed input TCU measures a voltage less than 1.00V at speed input pin · Cable/connector is defective and is contacted to vehicle ground · Speed sensor has an internal defect	Special mode for gear selection OP mode : Substitute clutch control If a failure is existing at turbine speed, TCU shifts to neutral OP mode : Limp home	· Check the cable from TCU to the sensor · Check the connectors · Check the speed sensor
3C	Logical error at output speed input TCU measures a turbine speed over a threshold and at the next moment the measured speed is zero · Cable/connector is defective and has bad contact · Speed sensor has an internal defect · Sensor gap has the wrong size	Special mode for gear selection OP mode : Substitute clutch control If a failure is existing at turbine speed, TCU shifts to neutral OP mode : Limp home	· Check the cable from TCU to the sensor · Check the connectors · Check the speed sensor · Check the sensor gap ※ This fault is reset after power up of TCU
3D	Turbine speed zero doesn't fit to other speed signals	-	· Not used
3E	Output speed zero doesn't fit to other speed signals If transmission is not neutral and the shifting has finished, TCU measures output speed zero and turbine speed or internal speed not equal to zero. · Speed sensor has an internal defect · Sensor gap has the wrong size	Special mode for gear selection OP mode : Substitute clutch control If a failure is existing at turbine speed, TCU shifts to neutral OP mode : Limp home	· Check the sensor signal of output speed sensor · Check the sensor gap of output speed sensor · Check the cable from TCU to the sensor ※ This fault is reset after power up of TCU
54	DCT1 timeout Timeout of CAN-message DCT1 from display computer · Interference on CAN-Bus · CAN wire/connector is broken · CAN wire/connector is defective and has contact to vehicle ground or battery voltage	OP mode : Normal	· Check display computer · Check wire of CAN-Bus · Check cable to display computer
55	JSS timeout Timeout of CAN-message JSS from joystick steering controller · Interference on CAN-Bus · CAN wire/connector is broken · CAN wire/connector is defective and has contact to vehicle ground or battery voltage	TCU shifts to neutral while joystick steering is active OP mode : Normal	· Check joystick steering controller · Check wire of CAN-Bus · Check cable to joystick steering controller
56	Engine CONF timeout Timeout of CAN-message engine CONF from engine controller · Interference on CAN-Bus · CAN wire/connector is broken · CAN wire/connector is defective and has contact to vehicle ground or battery voltage	OP mode : Substitute clutch control	· Check engine controller · Check wire of CAN-Bus · Check cable to engine controller

※ Some fault codes are not applied to this machine.

Fault code (Hex)	Meaning of the fault code possible reason for fault detection	Reaction of the TCU	Possible steps to repair
57	EEC1 timeout Timeout of CAN-message EEC1 from EEC controller · Interference on CAN-Bus · CAN wire/connector is broken · CAN wire/connector is defective and has contact to vehicle ground or battery voltage	OP mode : Substitute clutch control	· Check EEC controller · Check wire of CAN-Bus · Check cable to EEC controller
58	EEC3 timeout Timeout of CAN-message EEC3 from EEC controller · Interference on CAN-Bus · CAN wire/connector is broken · CAN wire/connector is defective an has contact to vehicle ground or battery voltage	OP mode : Substitute clutch control	· Check EEC controller · Check wire of CAN-Bus · Check cable to EEC controller
5C	Auto downshift signal CAN signal for automatic downshift is defective · Cluster controller is defective · Interference on CAN-Bus	No reaction	· Check cluster controller · Check wire of CAN-Bus · Check cable to cluster controller
5D	Manual downshift signal CAN signal for manual downshift is defective · Cluster controller is defective · Interference on CAN-Bus	No reaction	· Check cluster controller · Check wire of CAN-Bus · Check cable to controller
5E	CCO request signal CAN signal for CCO request is defective · Cluster controller is defective · Interference on CAN-Bus	No reaction	· Check cluster controller · Check wire of CAN-Bus · Check cable to controller
61	AEB request signal CAN signal for AEB request is defective · I/O controller is defective · Interference on CAN-Bus	No reaction OP mode : Normal	· Check I/O controller, Omron master · Check wire of CAN-Bus · Check cable to I/O controller, Omron master
64	Starting gear signal CAN signal for starting gear is defective · I/O controller is defective (illegal starting gear) · Interference on CAN-Bus	No reaction. TCU uses default starting gear OP mode : Normal	· Check I/O controller · Check wire of CAN-Bus · Check cable to I/O controller
65	Engine torque signal CAN signal for engine torque is defective · Engine controller is defective · Interference on CAN-Bus	OP mode : Substitute clutch control	· Check engine controller · Check wire of CAN-Bus · Check cable to engine controller
69	Reference engine torque signal CAN signal for reference of engine torque is defective · Engine controller is defective · Interference on CAN-Bus	OP mode : Substitute clutch control	· Check engine controller · Check wire of CAN-Bus · Check cable to engine controller
6A	Actual engine torque signal CAN signal for actual engine torque is defective · Engine controller is defective · Interference on CAN-Bus	OP mode : Substitute clutch control	· Check engine controller · Check wire of CAN-Bus · Check cable to engine controller

※ Some fault codes are not applied to this machine.

Fault code (Hex)	Meaning of the fault code possible reason for fault detection	Reaction of the TCU	Possible steps to repair
6E	EEC2 timeout Timeout of CAN-message EEC2 from EEC controller <ul style="list-style-type: none"> <li>· Interference on CAN-Bus</li> <li>· CAN wire/connector is broken</li> <li>· CAN wire/connector is defective and has contact to vehicle ground or battery voltage</li> </ul>	No reaction, TCU uses default signal accelerator pedal in idle position OP mode : Normal	<ul style="list-style-type: none"> <li>· Check EEC controller</li> <li>· Check wire of CAN-Bus</li> <li>· Check cable to EEC controller</li> </ul>
71	S.C. to battery voltage at clutch K1 The measured resistance value of the valve is out of limit, the voltage at K1 valve is too high <ul style="list-style-type: none"> <li>· Cable/connector is defective and has contact to battery voltage</li> <li>· Cable/connector is defective and has contact to another regulator output of the TCU</li> <li>· Regulator has an internal defect</li> </ul>	TCU shifts to neutral OP mode : Limp home If failure at another clutch is pending TCU shifts to neutral OP mode : TCU shutdown	<ul style="list-style-type: none"> <li>· Check the cable from TCU to the gearbox</li> <li>· Check the connectors from TCU to the gearbox</li> <li>· Check the regulator resistance*</li> <li>· Check internal wire harness of the gearbox</li> </ul> <p>* See page 3-74</p>
72	S.C. to ground at clutch K1 The measured resistance value of the valve is out of limit, the voltage at K1 valve is too low <ul style="list-style-type: none"> <li>· Cable/connector is defective and has contact to vehicle ground</li> <li>· Regulator has an internal defect</li> </ul>	TCU shifts to neutral OP mode : Limp home If failure at another clutch is pending TCU shifts to neutral OP mode : TCU shutdown	<ul style="list-style-type: none"> <li>· Check the cable from TCU to the gearbox</li> <li>· Check the connectors from gearbox to TCU</li> <li>· Check the regulator resistance*</li> <li>· Check internal wire harness of the gearbox</li> </ul> <p>* See page 3-74</p>
73	O.C. at clutch K1 The measured resistance value of the valve is out of limit <ul style="list-style-type: none"> <li>· Cable/connector is defective and has no contact to TCU</li> <li>· Regulator has an internal defect</li> </ul>	TCU shifts to neutral OP mode : Limp home If failure at another clutch is pending TCU shifts to neutral OP mode : TCU shutdown	<ul style="list-style-type: none"> <li>· Check the cable from TCU to the gearbox</li> <li>· Check the connectors from gearbox to TCU</li> <li>· Check the regulator resistance*</li> <li>· Check internal wire harness of the gearbox</li> </ul> <p>* See page 3-74</p>
74	S.C. to battery voltage at clutch K2 The measured resistance value of the valve is out of limit, the voltage at K2 valve is too high <ul style="list-style-type: none"> <li>· Cable/connector is defective and has contact to battery voltage</li> <li>· Cable/connector is defective and has contact to another regulator output of the TCU</li> <li>· Regulator has an internal defect</li> </ul>	TCU shifts to neutral OP mode : Limp home If failure at another clutch is pending TCU shifts to neutral OP mode : TCU shutdown	<ul style="list-style-type: none"> <li>· Check the cable from TCU to the gearbox</li> <li>· Check the connectors from gearbox to TCU</li> <li>· Check the regulator resistance*</li> <li>· Check internal wire harness of the gearbox</li> </ul> <p>* See page 3-74</p>
75	S.C. to ground at clutch K2 The measured resistance value of the valve is out of limit, the voltage at K2 valve is too low <ul style="list-style-type: none"> <li>· Cable/connector is defective and has contact to vehicle ground</li> <li>· Regulator has an internal defect</li> </ul>	TCU shifts to neutral OP mode : Limp home If failure at another clutch is pending TCU shifts to neutral OP mode : TCU shutdown	<ul style="list-style-type: none"> <li>· Check the cable from TCU to the gearbox</li> <li>· Check the connectors from gearbox to TCU</li> <li>· Check the regulator resistance*</li> <li>· Check internal wire harness of the gearbox</li> </ul> <p>* See page 3-74</p>

※ Some fault codes are not applied to this machine.



Fault code (Hex)	Meaning of the fault code possible reason for fault detection	Reaction of the TCU	Possible steps to repair
76	O.C. at clutch K2 The measured resistance value of the valve is out of limit · Cable/connector is defective and has no contact to TCU · Regulator has an internal defect	TCU shifts to neutral OP mode : Limp home If failure at another clutch is pending TCU shifts to neutral OP mode : TCU shutdown	· Check the cable from TCU to the gearbox · Check the connectors from gearbox to TCU · Check the regulator resistance* · Check internal wire harness of the gearbox * See page 3-74
77	S.C. to battery voltage at clutch K3 The measured resistance value of the valve is out of limit, the voltage at K3 valve is too high · Cable/connector is defective and has contact to battery voltage · Cable/connector is defective and has contact to another regulator output of the TCU · Regulator has an internal defect	TCU shifts to neutral OP mode : Limp home If failure at another clutch is pending TCU shifts to neutral OP mode : TCU shutdown	· Check the cable from TCU to the gearbox · Check the connectors from gearbox to TCU · Check the regulator resistance* · Check internal wire harness of the gearbox * See page 3-74
78	S.C. to ground at clutch K3 The measured resistance value of the valve is out of limit, the voltage at K3 valve is too low · Cable/connector is defective and has contact to vehicle ground · Regulator has an internal defect	TCU shifts to neutral OP mode : Limp home If failure at another clutch is pending TCU shifts to neutral OP mode : TCU shutdown	· Check the cable from TCU to the gearbox · Check the connectors from gearbox to TCU · Check the regulator resistance* · Check internal wire harness of the gearbox * See page 3-74
79	O.C. at clutch K3 The measured resistance value of the valve is out of limit · Cable/connector is defective and has no contact to TCU · Regulator has an internal defect	TCU shifts to neutral OP mode : Limp home If failure at another clutch is pending TCU shifts to neutral OP mode : TCU shutdown	· Check the cable from TCU to the gearbox · Check the connectors from gearbox to TCU · Check the regulator resistance* · Check internal wire harness of the gearbox * See page 3-74
7D	S.C. ground at engine derating device · Cable is defective and is contacted to vehicle ground · Engine derating device has an internal defect · Connector pin is contacted to vehicle ground	Engine derating will be on until TCU power down even if fault vanishes (Loose connection) OP mode : Normal	· Check the cable from TCU to the engine derating device · Check the connectors from engine derating device to TCU · Check the resistance* of engine derating device ※ Not used * See page 3-74
7E	S.C. battery voltage at engine derating device · Cable/connector is defective and is contacted to battery voltage · Engine derating device has an internal defect	No reaction OP mode : Normal	· Check the cable from TCU to the engine derating device · Check the connectors from backup alarm device to TCU · Check the resistance* of backup alarm device * See page 3-74

※ Some fault codes are not applied to this machine.

Fault code (Hex)	Meaning of the fault code possible reason for fault detection	Reaction of the TCU	Possible steps to repair
7F	O.C. at engine derating device TCU detected a wrong voltage at the output pin, that looks like a O.C. for this output pin · Cable is defective and has no connection to TCU · Engine derating device has an internal defect · Connector has no connection to TCU	No reaction OP mode : Normal	· Check the cable from TCU to the engine derating device · Check the connectors from engine derating device to TCU · Check the resistance* of engine derating device * See page 3-74
81	S.C. to battery voltage at clutch K4 The measured resistance value of the valve is out of limit, the voltage at K4 valve is too high · Cable/connector is defective and has contact to battery voltage · Cable/connector is defective and has contact to another regulator output of the TCU · Regulator has an internal defect	TCU shifts to neutral OP mode : Limp home If failure at another clutch is pending TCU shifts to neutral OP mode : TCU shutdown	· Check the cable from TCU to the gearbox · Check the connectors from gearbox to TCU · Check the regulator resistance* · Check internal wire harness of the gearbox * See page 3-74
82	S.C. to ground at clutch K4 The measured resistance value of the valve is out of limit, the voltage at K4 valve is too low · Cable/connector is defective and has contact to vehicle ground · Regulator has an internal defect	TCU shifts to neutral OP mode : Limp home If failure at another clutch is pending TCU shifts to neutral OP mode : TCU shutdown	· Check the cable from TCU to the engine derating device · Check the connectors from gearbox to TCU · Check the regulator resistance* · Check internal wire harness of the gearbox * See page 3-74
83	O.C. at clutch K4 The measured resistance value of the valve is out of limit · Cable/connector is defective and has contact to TCU · Regulator has an internal defect	TCU shifts to neutral OP mode : Limp home If failure at another clutch is pending TCU shifts to neutral OP mode : TCU shutdown	· Check the cable from TCU to the gearbox · Check the connectors from gearbox to TCU · Check the regulator resistance* · Check internal wire harness of the gearbox * See page 3-74
84	S.C. to battery voltage at clutch KV The measured resistance value of the valve is out of limit, the voltage at KV valve is too high · Cable/connector is defective and has contact to battery voltage · Cable/connector is defective and has contact to another regulator output of the TCU · Regulator has an internal defect	TCU shifts to neutral OP mode : Limp home If failure at another clutch is pending TCU shifts to neutral OP mode : TCU shutdown	· Check the cable from TCU to the gearbox · Check the connectors from gearbox to TCU · Check the regulator resistance* · Check internal wire harness of the gearbox * See page 3-74
85	S.C. to ground at clutch KV The measured resistance value of the valve is out of limit, the voltage at KV valve is too low · Cable/connector is defective and has contact to vehicle ground · Regulator has an internal defect	TCU shifts to neutral OP mode : Limp home If failure at another clutch is pending TCU shifts to neutral OP mode : TCU shutdown	· Check the cable from TCU to the gearbox · Check the connectors from gearbox to TCU · Check the regulator resistance* · Check internal wire harness of the gearbox * See page 3-74

※ Some fault codes are not applied to this machine.



Fault code (Hex)	Meaning of the fault code possible reason for fault detection	Reaction of the TCU	Possible steps to repair
86	O.C. at clutch KV The measured resistance value of the valve is out of limit · Cable/connector is defective and has contact to TCU · Regulator has an internal defect	TCU shifts to neutral OP mode : Limp home If failure at another clutch is pending TCU shifts to neutral OP mode : TCU shutdown	· Check the cable from TCU to the gearbox · Check the connectors from gearbox to TCU · Check the regulator resistance* · Check internal wire harness of the gearbox * See page 3-74
87	S.C. to battery voltage at clutch KR The measured resistance value of the valve is out of limit, the voltage at KR valve is too high · Cable/connector is defective and has contact to battery voltage · Cable/connector is defective and has contact to another regulator output of the TCU · Regulator has an internal defect	TCU shifts to neutral OP mode : Limp home If failure at another clutch is pending TCU shifts to neutral OP mode : TCU shutdown	· Check the cable from TCU to the gearbox · Check the connectors from gearbox to TCU · Check the regulator resistance* · Check internal wire harness of the gearbox * See page 3-74
88	S.C. to ground at clutch KR The measured resistance value of the valve is out of limit, the voltage at KR valve is too low · Cable/connector is defective and has contact to vehicle ground · Regulator has an internal defect	TCU shifts to neutral OP mode : Limp home If failure at another clutch is pending TCU shifts to neutral OP mode : TCU shutdown	· Check the cable from TCU to the gearbox · Check the connectors from gearbox to TCU · Check the regulator resistance* · Check internal wire harness of the gearbox * See page 3-74
89	O.C. at clutch KR The measured resistance value of the valve is out of limit · Cable/connector is defective and has no contact to TCU · Regulator has an internal defect	TCU shifts to neutral OP mode : Limp home If failure at another clutch is pending TCU shifts to neutral OP mode : TCU shutdown	· Check the cable from TCU to the gearbox · Check the connectors from gearbox to TCU · Check the regulator resistance* · Check internal wire harness of the gearbox * See page 3-74
91	S.C. to ground at relay reverse warning alarm TCU detected a wrong voltage at the output pin, that looks like a S.C. to vehicle ground · Cable is defective and is contact to vehicle ground · Backup alarm device has an internal defect · Connector pin is contacted to vehicle ground	Backup alarm will be on until TCU power down even if fault vanishes (Loose connection) OP mode : Normal	· Check the cable from TCU to the backup alarm device · Check the connectors from backup alarm device to TCU · Check the resistance* of backup alarm device * See page 3-74
92	S.C. to battery voltage at relay reverse warning alarm TCU detected a wrong voltage at the output pin, that looks like a S.C. to battery voltage · Cable is defective and is contacted to battery voltage · Backup alarm device has an internal defect · Connector pin is contacted to battery voltage	No reaction OP mode : Normal	· Check the cable from TCU to the backup alarm device · Check the connectors from backup alarm device to TCU · Check the resistance* of backup alarm device * See page 3-74

※ Some fault codes are not applied to this machine.

Fault code (Hex)	Meaning of the fault code possible reason for fault detection	Reaction of the TCU	Possible steps to repair
93	O.C. at relay reverse warning alarm TCU detected a wrong voltage at the output pin, that looks like a O.C. for this output pin · Cable is defective and has no connection to TCU · Backup alarm device has an internal defect · Connector has no connection to TCU	No reaction OP mode : Normal	· Check the cable from TCU to the backup alarm device · Check the connectors from backup alarm device to TCU · Check the resistance* of backup alarm device * See page 3-74
94	S.C. to ground at relay starter interlock TCU detected a wrong voltage at the output pin, that looks like a S.C. to vehicle ground · Cable is defective and is connection to vehicle ground · Starter interlock relay has an internal defect · Connector pin is contacted to vehicle ground	No reaction OP mode : Normal	· Check the cable from TCU to the stater interlock relay · Check the connectors from starter interlock relay to TCU · Check the resistance* of starter interlock relay * See page 3-74
95	S.C. to battery voltage at relay starter interlock TCU detected a wrong voltage at the output pin, that looks like a S.C. to battery voltage · Cable is defective and has no connection to battery voltage · Starter interlock relay has an internal defect · Connector pin is contacted to battery voltage	No reaction OP mode : Normal	· Check the cable from TCU to the starter interlock relay · Check the connectors from starter interlock relay to TCU · Check the resistance* of starter interlock relay * See page 3-74
96	O.C. at relay starter interlock TCU detected a wrong voltage at the output pin, that looks like a O.C. for this output pin · Cable is defective and has no connection to TCU · Starter interlock relay has an internal defect · Connector has no connection to TCU	No reaction OP mode : Normal	· Check the cable from TCU to the starter interlock relay · Check the connectors from starter interlock relay to TCU · Check the resistance* of starter interlock relay * See page 3-74
9A	S.C. to ground at converter lock up clutch solenoid TCU detected a wrong voltage at the output pin, that looks like a S.C. to vehicle ground · Cable is defective and is contacted to vehicle ground · Converter clutch solenoid has an internal defect · Connector pin is contacted to vehicle ground	No reaction OP mode : Normal	· Check the cable from TCU to the converter clutch solenoid · Check the connectors from converter clutch solenoid to TCU · Check the resistance* of converter clutch solenoid * See page 3-74

※ Some fault codes are not applied to this machine.

Fault code (Hex)	Meaning of the fault code possible reason for fault detection	Reaction of the TCU	Possible steps to repair
9B	O.C. at converter lock up clutch solenoid TCU detected a wrong voltage at the output pin, that looks like a O.C. for this output pin · Cable is defective and has no connection to TCU · Converter clutch solenoid has an internal defect · Connector has no connection to TCU	Converter clutch always open, retarder not available OP mode : Normal	· Check the cable from TCU to the converter clutch solenoid · Check the connectors from converter clutch solenoid to TCU · Check the resistance* of converter clutch solenoid * See page 3-74
9C	S.C. to battery voltage at converter lock up clutch solenoid TCU detected a wrong voltage at the output pin, that looks like a S.C. to battery voltage · Cable is defective and has no contacted to battery voltage · Converter clutch solenoid has an internal defect · Connector pin is contacted to battery voltage	No reaction OP mode : Normal	· Check the cable from TCU to the converter clutch solenoid · Check the connectors from converter clutch solenoid to TCU · Check the resistance* of converter clutch solenoid * See page 3-74
A1	S.C. to ground at difflock or axle connection solenoid TCU detected a wrong voltage at the output pin, that looks like a S.C. to vehicle ground · Cable is defective and is contacted to vehicle ground · Difflock solenoid has an internal defect · Connector pin is contacted to vehicle ground	No reaction OP mode : Normal	· Check the cable from TCU to the difflock solenoid · Check the connectors from difflock solenoid to TCU · Check the resistance* of difflock solenoid * See page 3-74
A2	S.C. to battery voltage at difflock or axle connection solenoid TCU detected a wrong voltage at the output pin, that looks like a S.C. to battery voltage · Cable is defective and has no connection to battery voltage · Difflock solenoid has an internal defect · Connector pin is contacted to battery voltage	No reaction OP mode : Normal	· Check the cable from TCU to the difflock solenoid · Check the connectors from difflock solenoid to TCU · Check the resistance* of difflock solenoid * See page 3-74
A3	O.C. at difflock or axle connection solenoid TCU detected a wrong voltage at the output pin, that looks like a O.C. for this output pin · Cable is defective and has no connection to TCU · Difflock solenoid has an internal defect · Connector has no connection to TCU	No reaction OP mode : Normal	· Check the cable from TCU to the difflock solenoid · Check the connectors from difflock solenoid to TCU · Check the resistance* of difflock solenoid * See page 3-74

※ Some fault codes are not applied to this machine.

Fault code (Hex)	Meaning of the fault code possible reason for fault detection	Reaction of the TCU	Possible steps to repair
A4	S.C. to ground at warning signal output TCU detected a wrong voltage at the output pin, that looks like a S.C. to vehicle ground · Cable is defective and is contacted to vehicle ground · Warning device has an internal defect · Connector pin is contacted to vehicle ground	No reaction OP mode : Normal	· Check the cable from TCU to the warning device · Check the connectors from warning device to TCU · Check the resistance* of warning device * See page 3-74
A5	O.C. voltage at warning signal output TCU detected a wrong voltage at the output pin, that looks like a O.C. for this output pin · Cable is defective and has no connection to TCU · Warning device has an internal defect · Connector has no connection to TCU	No reaction OP mode : Normal	· Check the cable from TCU to the warning device · Check the connectors from warning device to TCU · Check the resistance* of warning device * See page 3-74
A6	S.C. to battery voltage at warning signal output TCU detected a wrong voltage at the output pin, that looks like a S.C. to battery voltage · Cable is defective and has is contacted to battery voltage · Warning device has an internal defect · Connector pin is contacted to battery voltage	No reaction OP mode : Normal	· Check the cable from TCU to the warning device · Check the connectors from warning device to TCU · Check the resistance* of warning device * See page 3-74
B1	Slippage at clutch K1 TCU calculates a differential speed at closed clutch K1. If this calculated value is out of range, TCU interprets this as slipping clutch · Low pressure at clutch K1 · Low main pressure · Wrong signal at internal speed sensor · Wrong signal at output speed sensor · Wrong size of the sensor gap · Clutch is defective	TCU shifts to neutral OP mode : Limp home If failure at another clutch is pending TCU shifts to neutral OP mode : TCU shutdown	· Check pressure at clutch K1 · Check main pressure in the system · Check sensor gap at internal speed sensor · Check sensor gap at output speed sensor · Check signal at internal speed sensor · Check signal at output speed sensor · Replace clutch
B2	Slippage at clutch K2 TCU calculates a differential speed at closed clutch K2. If this calculated value is out of range, TCU interprets this as slipping clutch · Low pressure at clutch K2 · Low main pressure · Wrong signal at internal speed sensor · Wrong signal at output speed sensor · Wrong size of the sensor gap · Clutch is defective	TCU shifts to neutral OP mode : Limp home If failure at another clutch is pending TCU shifts to neutral OP mode : TCU shutdown	· Check pressure at clutch K2 · Check main pressure in the system · Check sensor gap at internal speed sensor · Check sensor gap at output speed sensor · Check signal at internal speed sensor · Check signal at output speed sensor · Replace clutch

※ Some fault codes are not applied to this machine.

Fault code (Hex)	Meaning of the fault code possible reason for fault detection	Reaction of the TCU	Possible steps to repair
B3	Slippage at clutch K3 TCU calculates a differential speed at closed clutch K3. If this calculated value is out of range, TCU interprets this as slipping clutch · Low pressure at clutch K3 · Low main pressure · Wrong signal at internal speed sensor · Wrong signal at output speed sensor · Wrong size of the sensor gap · Clutch is defective	TCU shifts to neutral OP mode : Limp home If failure at another clutch is pending TCU shifts to neutral OP mode : TCU shutdown	· Check pressure at clutch K3 · Check main pressure in the system · Check sensor gap at internal speed sensor · Check sensor gap at output speed sensor · Check signal at internal speed sensor · Check signal at output speed sensor Replace clutch
B4	Slippage at clutch K4 TCU calculates a differential speed at closed clutch K4. If this calculated value is out of range, TCU interprets this as slipping clutch · Low pressure at clutch K4 · Low main pressure · Wrong signal at internal speed sensor · Wrong signal at turbine speed sensor · Wrong size of the sensor gap · Clutch is defective	TCU shifts to neutral OP mode : Limp home If failure at another clutch is pending TCU shifts to neutral OP mode : TCU shutdown	· Check pressure at clutch K4 Check main pressure in the system · Check sensor gap at internal speed sensor · Check sensor gap at turbine speed sensor · Check signal at internal speed sensor · Check signal at turbine speed sensor Replace clutch
B5	Slippage at clutch KV TCU calculates a differential speed at closed clutch KV. If this calculated value is out of range, TCU interprets this as slipping clutch · Low pressure at clutch KV · Low main pressure · Wrong signal at internal speed sensor · Wrong signal at turbine speed sensor · Wrong size of the sensor gap · Clutch is defective	TCU shifts to neutral OP mode : Limp home If failure at another clutch is pending TCU shifts to neutral OP mode : TCU shutdown	· Check pressure at clutch KV · Check main pressure in the system · Check sensor gap at internal speed sensor · Check sensor gap at turbine speed sensor · Check signal at internal speed sensor · Check signal at turbine speed sensor · Replace clutch
B6	Slippage at clutch KR TCU calculates a differential speed at closed clutch KR. If this calculated value is out of range, TCU interprets this as slipping clutch · Low pressure at clutch KR · Low main pressure · Wrong signal at internal speed sensor · Wrong signal at turbine speed sensor · Wrong size of the sensor gap · Clutch is defective	TCU shifts to neutral OP mode : Limp home If failure at another clutch is pending TCU shifts to neutral OP mode : TCU shutdown	· Check pressure at clutch KR Check main pressure in the system · Check sensor gap at internal speed sensor · Check sensor gap at turbine speed sensor · Check signal at internal speed sensor · Check signal at turbine speed sensor · Replace clutch
B7	Overtemp sump TCU measured a temperature in the oil sump that is over the allowed threshold.	No reaction OP mode : Normal	· Cool down machine · Check oil level · Check temperature sensor
B9	Overspend engine	Retarder applies OP mode : Normal	-
BA	Differential pressure oil filter TCU measured a voltage at differential pressure switch out of the allowed range · Oil filter is polluted · Cable/connector is broken or cable/connector is contacted to battery voltage or vehicle ground · Differential pressure switch is defective	No reaction OP mode : Normal	· Check oil filter · Check wiring from TCU to differential pressure switch · Check differential pressure switch(Measure resistance)

※ Some fault codes are not applied to this machine.

Fault code (Hex)	Meaning of the fault code possible reason for fault detection	Reaction of the TCU	Possible steps to repair
BB	Slippage at converter lockup clutch TCU calculates a differential speed at closed converter lockup clutch. If this calculated value is out of range, TCU interprets this as slipping clutch <ul style="list-style-type: none"> <li>· Low pressure at converter lockup clutch</li> <li>· Low main pressure</li> <li>· Wrong signal at engine speed sensor</li> <li>· Wrong signal at turbine speed sensor</li> <li>· Wrong size of the sensor gap</li> <li>· Clutch is defective</li> </ul>	No reaction OP mode : Normal	<ul style="list-style-type: none"> <li>· Check pressure at converter lockup clutch</li> <li>· Check main pressure in the system</li> <li>· Check sensor gap at engine speed sensor</li> <li>· Check sensor gap at turbine speed sensor</li> <li>· Check signal at engine speed sensor</li> <li>· Check signal at turbine speed sensor</li> <li>· Replace clutch</li> </ul>
C0	Engine torque or engine power overload TCU calculates an engine torque or engine power above the defined thresholds	OP mode : Normal	
C1	Transmission output torque overload TCU calculates an transmission output torque above the defined threshold	OP mode : Normal	
C2	Transmission input torque overload TCU calculates an transmission input torque above the defined threshold	programmable : No reaction or shift to neutral OP mode : Normal	
C3	Overtemp converter output TCU measured a oil temperature at the converter output that is the allowed threshold	No reaction OP mode : Normal	<ul style="list-style-type: none"> <li>· Cool down machine</li> <li>· Check oil level</li> <li>· Check temperature sensor</li> </ul>
C4	S.C. to ground at joystick status indicator TCU detected a wrong voltage at the output pin, that looks like a S.C. to vehicle ground <ul style="list-style-type: none"> <li>· Cable is defective and is contacted to vehicle ground</li> <li>· Joystick status indicator has an internal defect</li> <li>· Connector pin is contacted to vehicle ground</li> </ul>	No reaction OP mode : Normal	<ul style="list-style-type: none"> <li>· Check the cable from TCU to joystick status indicator</li> <li>· Check the connectors from joystick status indicator to TCU</li> <li>· Check the resistance* of joystick status indicator</li> </ul> <p>* See page 3-74</p>
C5	S.C. to battery voltage at joystick status indicator TCU detected a wrong voltage at the output pin, that looks like a S.C. to battery voltage <ul style="list-style-type: none"> <li>· Cable is defective and is contacted to battery voltage</li> <li>· Joystick status indicator has an internal defect</li> <li>· Connector pin is contacted to battery voltage</li> </ul>	No reaction OP mode : Normal	<ul style="list-style-type: none"> <li>· Check the cable from TCU to joystick status indicator</li> <li>· Check the connectors from joystick status indicator to TCU</li> <li>· Check the resistance* of joystick status indicator</li> </ul> <p>* See page 3-74</p>

※ Some fault codes are not applied to this machine.



Fault code (Hex)	Meaning of the fault code possible reason for fault detection	Reaction of the TCU	Possible steps to repair
C6	O.C. at joystick status indicator TCU detected a wrong voltage at the output pin, that looks like a O.C. for this output pin · Cable is defective and has no connection to TCU · Joystick status indicator has an internal defect · Connector pin has no connection to TCU	No reaction OP mode : Normal	· Check the cable from TCU to joystick status indicator · Check the connectors from joystick status indicator to TCU · Check the resistance* of joystick status indicator * See page 3-74
D1	S.C. to battery voltage at power supply for sensors TCU measures more than 6V at the pin AU1 (5V sensor supply)	See fault codes No.21 to 2C	· Check cables and connectors to sensors, which are supplied from AU1 · Check the power supply at the pin AU1(Should be appx. 5V) · Fault codes No.21 to No.2C may be reaction of this fault
D2	S.C. to ground at power supply for sensors TCU measures less than 4V at the pin AU1 (5V sensor supply)	See fault codes No.21 to 2C	· Check cables and connectors to sensors, which are supplied from AU1 · Check the power supply at the pin AU1(Should be appx. 5V) · Fault codes No.21 to No.2C may be reaction of this fault
D3	Low voltage at battery Measured voltage at power supply is lower than 18V(24V device)	Shift to neutral OP mode : TCU shutdown	· Check power supply battery · Check cables from batteries to TCU · Check connectors from batteries to TCU
D4	High voltage at battery Measured voltage at power supply is higher than 32.5V(24V device)	Shift to neutral OP mode : TCU shutdown	· Check power supply battery · Check cables from batteries to TCU · Check connectors from batteries to TCU
D5	Error at valve power supply VPS1 TCU switched on VPS1 and measured VPS1 is off or TCU switched off VPS1 and measured VPS1 is still on · Cable or connectors are defect and are contacted to battery voltage · Cable or connectors are defect and are contacted to vehicle ground · Permanent power supply KL30 missing · TCU has an internal defect	Shift to neutral OP mode : TCU shutdown	· Check fuse · Check cables from gearbox to TCU · Check connectors from gearbox to TCU · Replace TCU
D6	Error at valve power supply VPS2 TCU switched on VPS2 and measured VPS2 is off or TCU switched off VPS2 and measured VPS2 is still on · Cable or connectors are defect and are contacted to battery voltage · Cable or connectors are defect and are contacted to vehicle ground · Permanent power supply KL30 missing · TCU has an internal defect	Shift to neutral OP mode : TCU shutdown	· Check fuse · Check cables from gearbox to TCU · Check connectors from gearbox to TCU · Replace TCU

※ Some fault codes are not applied to this machine.



Fault code (Hex)	Meaning of the fault code possible reason for fault detection	Reaction of the TCU	Possible steps to repair
E3	S.C. to battery voltage at display output TCU sends data to the display and measures always a high voltage level on the connector · Cable or connectors are defective and are contacted to battery voltage · Display has an internal defect	No reaction OP mode : Normal	· Check the cable from TCU to the display · Check the connectors at the display · Change display
E4	S.C. to ground at display output TCU sends data to the display and measures always a high voltage level on the connector · Cable or connectors are defective and are contacted to battery voltage · Display has an internal defect	No reaction OP mode : Normal	· Check the cable from TCU to the display · Check the connectors at the display · Change display
E5	Communication failure on DeviceNet	Shift to neutral OP mode : TCU shutdown	· Check Omron master · Check wire of DeviceNet-Bus · Check cable to Omron master
F1	General EEPROM fault TCU can't read non volatile memory · TCU is defective	No reaction OP mode : Normal	· Replace TCU ※ Often shown together with fault code F2
F2	Configuration lost TCU has lost the correct configuration and can't control the transmission · Interference during saving data on non volatile memory · TCU is brand new or from another vehicle	Transmission stay neutral OP mode : TCU shutdown	· Reprogram the correct configuration for the vehicle (e.g. with cluster controller,...)
F3	Application error Something of this application is wrong	Transmission stay neutral OP mode : TCU shutdown	· Replace TCU ※ This fault occurs only if an test engineer did something wrong in the application of the vehicle
F5	Clutch failure AEB was not able to adjust clutch filling parameters · One of the AEB-Values is out of limit	Transmission stay neutral OP mode : TCU shutdown	· Check clutch ※ TCU shows also the affected clutch on the display
F6	Clutch adjustment data lost TCU was not able to read correct clutch adjustment parameters · Interference during saving data on non volatile memory · TCU is brand new	No reaction, Default values : 0 for AEB Offsets used OP mode : Normal	· Execute AEB and brake sensor calibration
F7	Substitute clutch control · Transmission input torque wrong · Engine retarder torque wrong · Speed signal (s) defective	OP mode : Substitute clutch control	· Check engine retarder torque · Check speed sensors

※ Some fault codes are not applied to this machine.

## 5) MEASURING OF RESISTANCE AT ACTUATOR/SENSOR AND CABLE

### (1) Actuator

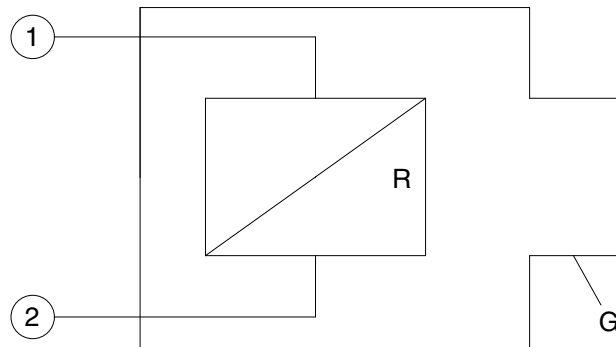

76043PT19

- Open circuit  $R_{12} = R_{1G} = R_{2G} = \infty$   
 Short cut to ground  $R_{12} = R$ ;  $R_{1G} = 0$ ,  $R_{2G} = R$  or  $R_{1G} = R$ ,  $R_{2G} = 0$   
 (For S.C. to ground, G is connected to vehicle ground)  
 Short cut to battery  $R_{12} = R$ ;  $R_{1G} = 0$ ,  $R_{2G} = R$  or  $R_{1G} = R$ ,  $R_{2G} = 0$   
 (For S.C. to battery, G is connected to battery voltage)

### (2) Cable

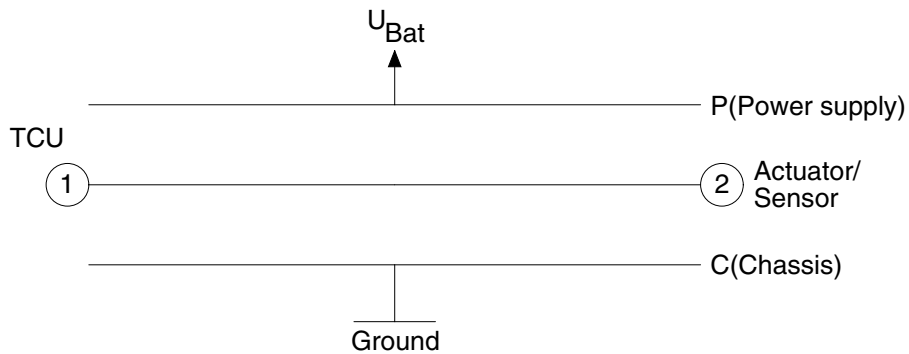

76043PT20

- Open circuit  $R_{12} = R_{1P} = R_{1C} = R_{2P} = R_{2C} = \infty$   
 Short cut to ground  $R_{12} = 0$ ;  $R_{1C} = R_{2C} = 0$ ,  $R_{1P} = R_{2P} = \infty$   
 Short cut to battery  $R_{12} = 0$ ;  $R_{1C} = R_{2C} = 0$ ,  $R_{1P} = R_{2P} = 0$

## 5. AXLE

### 1) OPERATION

- The power from the engine passes through torque converter, transmission and drive shafts, and is then sent to the front and rear axles.
- Inside the axles, the power passes from the bevel pinion to the bevel gear and is sent at right angles. At the same time, the speed is reduced and passes through the both differentials to the axle shafts. The power of the axle shafts is further reduced by planetary-gear-type final drives and is sent to the wheels.

#### (1) Front axle

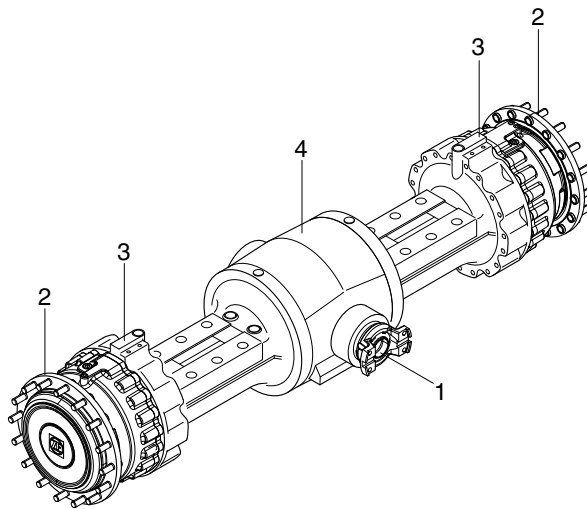

- 1 Input  
4 Axle housing

2 Output

3 Brake

7579A3PT15

#### (2) Rear axle

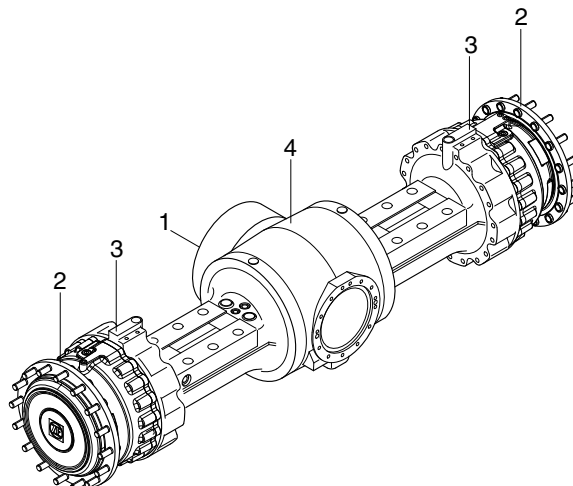

- 1 Input  
4 Axle housing

2 Output

3 Brake

7579A3PT16

## 2) DIFFERENTIAL

### (1) Description

When the machine makes a turn, the outside wheel must rotate faster than the inside wheel. A differential is a device which continuously transmits power to the right and left wheels while allowing them to turn a different speeds, during a turn.

The power from the drive shaft passes through bevel pinion (1) and is transmitted to the bevel gear (2). The bevel gear changes the direction of the motive force by 90 degree, and at the same time reduces the speed.

It then transmits the motive force through the differential (3) to the axle gear shaft (4).

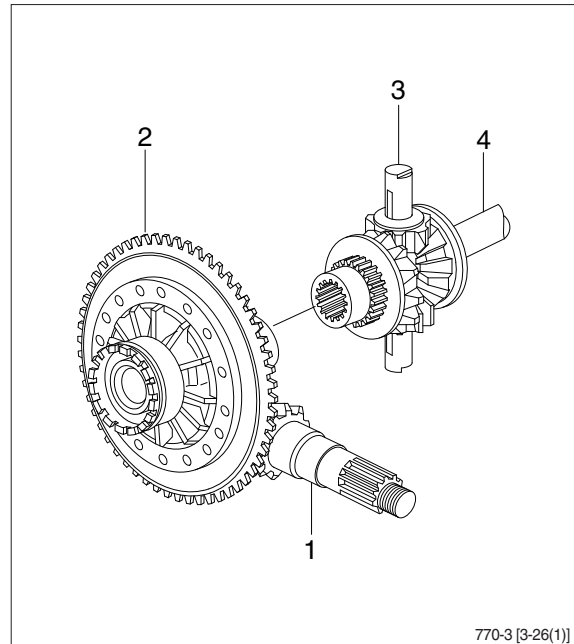

### (2) When driving straight forward

When the machine is being driven straight forward and the right and left wheels are rotating at the same speed, so the pinion gear inside the differential assembly do not rotate. The motive force of the carrier is send through the pinion gear and the side gear, therefore the power is equally transmitted to the left and right axle gear shaft.

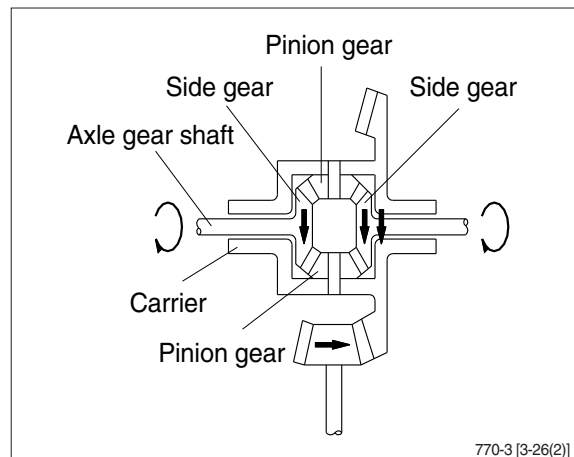

### (3) When turning

When turning, the rotating speed of the left and right wheels is different, so the pinion gear and side gear inside the differential assembly rotate in accordance with the difference between the rotating speed of the left and right wheels.

The power of the carrier is then transmitted to the axle gear shafts.

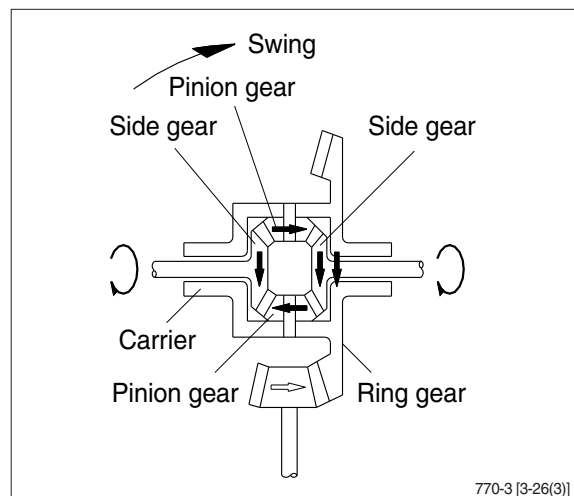

## 6. TIRE AND WHEEL

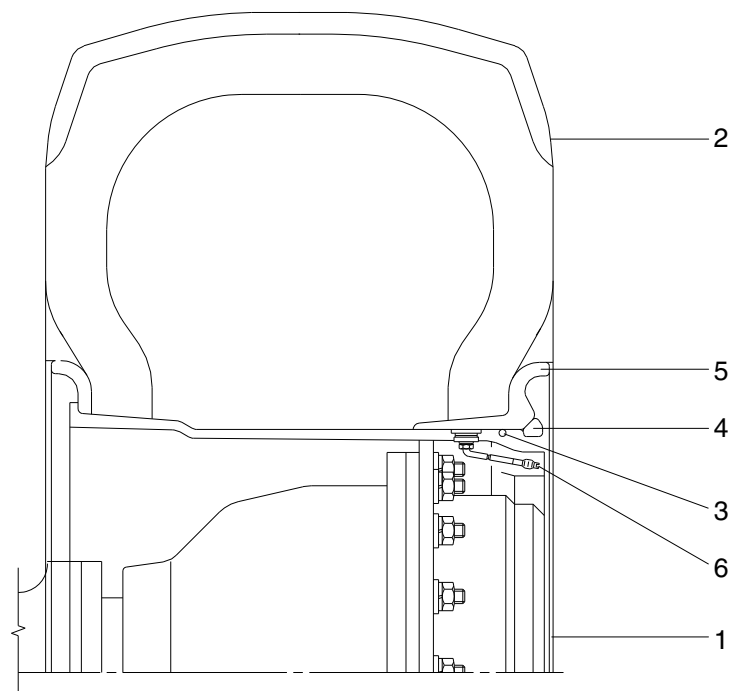

7407APT10

- |   |           |   |           |   |                |
|---|-----------|---|-----------|---|----------------|
| 1 | Wheel rim | 3 | O-ring    | 5 | Side ring      |
| 2 | Tire      | 4 | Lock ring | 6 | Valve assembly |

- 1) The tire acts to absorb the shock from the ground surface to the machine, and at the same time they must rotate in contact with the ground to gain the power which drives the machine.
- 2) Various types of tires are available to suit the purpose. Therefore it is very important to select the correct tires for the type of work and bucket capacity.

## GROUP 2 OPERATIONAL CHECKS AND TROUBLESHOOTING

### 1. POWER TRAIN OPERATIONAL CHECKS

This procedure is designed so that the mechanic can make a quick check of the system using a minimum amount of diagnostic equipment. If you need additional information, read Structure and function, Group 1.

A location will be required which is level and has adequate space to complete the checks.

The engine and all other major components must be at operating temperature for some checks.

Locate system check in the left column and read completely, following the sequence from left to right. Read each check completely before performing.









At the end of each check, if no problem is found(OK), that check is complete or an additional check is needed. If problem is indicated(NOT OK), you will be given repair required and group location.

If verification is needed, you will be given next best source of information :



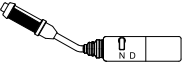

Chapter 2 : Troubleshooting

Group 3 : Tests and adjustments

※ Transmission oil must be at operating temperature for these checks.

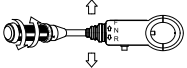
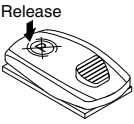
Item	Description	Service action
<b>Transmission oil warm-up procedure</b>	 <p>Start engine. Apply service brakes and release parking brake.</p> <p>Select T/M shift mode to MANUAL mode.</p> <p>Move gear selector lever to 3rd speed.</p> <p>Move gear selector lever to forward "F" position.</p>  <p>Increase engine speed to high idle for 30 seconds.</p>  <p>Move gear selector lever to neutral "N" position and run for 15 seconds.</p> <p>Repeat procedure until transmission temperature gauge arrow points to bar above dial.</p>	<p><b>OK</b> Check completed.</p>
<b>Gear selector lever and neutral lock latch checks</b> Engine OFF.	 <p>Move gear selector lever to each position.</p> <p><b>NOTE</b> : Gear selector lever position changes slightly as steering column is tilted.</p> <p><b>FEEL</b> : Lever must move freely through all positions.</p>  <p>Engage neutral lock.</p> <p>Apply slight effort to move lever into forward (F) and reverse (R).</p> <p><b>LOOK</b> : Neutral lock must stay engaged.</p>	<p><b>OK</b> Check completed.</p> <p><b>NOT OK</b> Repair lock or replace switch.</p>
<b>Automatic shifting check</b>	 <p>Start engine.</p> <p>Move gear selector lever to 4th speed.</p> <p>Select T/M shift mode to AL (auto light) mode.</p>  <p><b>LOOK</b> : Automatic sign on cluster.</p> <p>Move gear selector lever to forward or reverse position.</p>  <p>Increase engine rpm.</p> <p><b>LOOK</b> : Speed on cluster must vary with machine speed.</p>	<p><b>OK</b> Check completed.</p> <p><b>NOT OK</b> Go to transmission fault code group at page 3-59~3-73. Repair or replace the monitor or harness.</p>

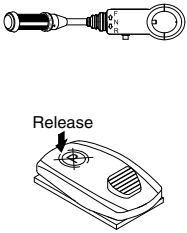
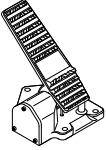
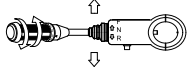
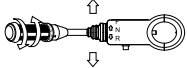

Item	Description	Service action
<p><b>Transmission noise check</b> Engine running.</p>	 <p>Run engine at approximately 1600 rpm.</p> <p>Drive unit with transmission in each forward and reverse speed.</p> <p><b>LISTEN</b> : Transmission must not make excessive noise in any range.</p> <p>Engine rpm must not "lug down" as unit is shifted between gears.</p>	<p><b>OK</b> Check completed.</p> <p><b>NOT OK</b> Go to transmission makes excessive noise, chapter 2 in this group.</p>
<p><b>Transmission "quick shift" check</b> Engine running.</p>	 <p>Release</p>  <p>MANUAL mode</p>   <p>AL mode</p> <p>Release parking brake and select T/M shift mode to MANUAL mode.</p> <p>Shift to 2nd forward.</p> <p>Drive machine at approximately 5km/h and press gear selector lever kick down switch or RCV levers switch once.</p> <p><b>LOOK/FEEL</b> : Transmission must shift to and remain in 1st gear.</p> <p>Press gear selector lever kick down switch once.</p> <p><b>LOOK/FEEL</b> : Transmission must shift back to 2nd gear.</p> <p>Shift to (3rd or 4th) gear and press gear selector lever kick down switch once.</p> <p><b>LOOK/FEEL</b> : Transmission must not shift down.</p> <p>Select T/M shift mode to AL (auto light) mode.</p> <p>Drive machine at approximately 90% speed of max speed in each gear (2nd or 3rd or 4th).</p> <p>Shift to (2nd or 3rd or 4th) gear in each forward and reverse speed and press gear selector kick down lever switch or RCV lever switch once.</p> <p><b>LOOK/FEEL</b> :</p> <p>If shift down quickly from current gear to one step lower speed and recover to original speed quickly when push the switch one more time. (mode 1)</p> <p>If shifts down from current gear to one step lower speed when push the switch everytime and recover when push the switch in 1st gear. (mode 2)</p>	<p><b>OK</b> Check completed.</p> <p><b>NOT OK</b> Check connector at base of control valve.</p> <p><b>IF OK</b> Go to transmission controller circuit in group 1.</p>

Item	Description	Service action
<p><b>Forward, reverse and 4th speed clutch pack drag check</b>            ※ <b>Transmission must be warmed up for this check.</b>            Engine running.</p>	  <p>Park unit on level surface.            Apply service brakes.            Move gear selector lever to neutral.            Move gear selector lever to 1st.            Release parking brake and service brakes.            Run engine at low idle.  <b>LOOK</b> : Unit must not move in either direction.  <b>NOTE</b> : If unit moves forward, either the forward pack or the 4th speed pack is dragging.</p>	<p><b>OK</b>            Check completed.  <b>NOT OK</b>            If unit moves, repair transmission.</p>
<p><b>Transmission shift modulation check</b>            Engine running.</p>	 <p>Run engine at approximately 1300 rpm.            Put transmission in 1st forward, shift several times from forward to reverse and reverse to forward. Repeat check in 2nd gear.  <b>LOOK</b> : Unit must slow down and change direction smoothly.</p>	<p><b>OK</b>            Check completed.  <b>NOT OK</b>            Go to unit shifts too fast, chapter 2 in this group.</p>
<p><b>Torque converter check</b></p>	 <p>Start engine. Apply service brakes and release parking brake.            Move gear selector lever to 3rd speed.            Move gear selector control lever to forward "F" position.            Increase engine speed to high idle.  <b>LOOK</b> : Torque converter stall rpm must be within the following range.            Stall rpm : <math>1860 \pm 70</math> rpm            Move gear selector control lever to neutral "N" position and run for 15 seconds.</p>	<p><b>OK</b>            Check completed.  <b>NOT OK</b>            If stall rpm are too low or too high, problem may be engine power or torque converter.  <b>IF OK</b>            Replace transmission torque converter.</p>

## 2. TROUBLESHOOTING

### 1) TRANSMISSION

※ Diagnose malfunction charts are arranged from most probable and simplest to verify, to least likely, more difficult to verify. Remember the following steps when troubleshooting a problem :

Step 1. Operational check out procedure (See group 3 in section 1.)

Step 2. Operational checks (In this group.)

Step 3. Troubleshooting

Step 4. Tests and/or adjustments (See group 3.)

Problem	Cause	Remedy
Transmission slippage	<p>Low oil level.</p> <p>Wrong oil grade.</p> <p>Restricted transmission pump suction screen.</p> <p>Leak in transmission control valve or gasket.</p> <p>Low transmission pump flow due to worn pump.</p> <p>Weak or broken pressure regulating valve spring.</p>	<p>Add oil.</p> <p>Change oil.</p> <p>Remove and clean screen.</p> <p>Remove valve and inspect gaskets.</p> <p>Do transmission pump flow test.</p> <p>Do transmission system pressure test.</p>
Error code on display	Something wrong in transmission.	Go to transmission fault code group at page 3-59~3-73.

Problem	Cause	Remedy
Machine will not move	<p>Low oil level.</p> <p>Applied park brake.</p> <p>No power to transmission controller.</p> <p>Malfunctioning parking brake solenoid valve.</p> <p>Restricted orifice of PPC valve.</p> <p>Excessive leakage in transmission element.</p> <p>Worn clutch disks.</p> <p>Low or no transmission pressure.</p> <p>Service brake will not release.</p> <p>Failed torque converter.</p> <p>Broken shafts or gears.</p> <p>Broken drive shafts.</p> <p>Broken ring or pinion gear.</p>	<p>Add oil.</p> <p>Check parking brake fuse. Check continuity to parking brake switch.</p> <p>Check transmission controller fuse.</p> <p>Remove and inspect parking brake solenoid valve. Check for power to solenoid valve.</p> <p>Remove orifice and check for contamination and/or plugging. (Do not remove valve housing for this purpose.)</p> <p>Do transmission element leakage test using system pressure.</p> <p>Repair transmission.</p> <p>See transmission pressure is low in this group.</p> <p>Do brake pedal operational check. Do service and park system drag checks.</p> <p>Do torque converter stall test. If engine pulldown in normal, torque converter is good.</p> <p>Drain transmission to determine if large pieces of metal contamination are present.</p> <p>Inspect drive shafts and universal joints for external damage. Repair.</p> <p>If drive shaft rotate with transmission in gear but machine does not move, a differential failure is indicated. Repair.</p>
Machine does not engage in low gear	<p>Malfunctioning transmission control solenoid valve.</p> <p>Stuck spool in transmission control valve.</p> <p>Stuck PPC valve.</p> <p>Malfunctioning transmission speed sensor.</p>	<p>Check solenoid valve.</p> <p>Remove and inspect transmission control valve spools.</p> <p>Remove end cover to inspect PPC valve. Replace if necessary.</p> <p>Check speed sensor.</p>

Problem	Cause	Remedy
Transmission pressure is low (all gears)	Low oil level.	Check transmission oil level and refill if necessary.
	Failed transmission pressure switch.	Verify transmission system pressure. Do transmission system pressure test.
	Plugged suction strainer.	Transmission pump may be noisy if transmission suction screen is clogged. Drain transmission. Remove and clean suction screen. Also, check condition of transmission filter.
	Stuck transmission pressure regulating valve or broken spring.	Remove transmission pressure regulating valve. Inspect for damage (See transmission control valve).
	Failed control valve gasket.	Inspect transmission control valve for external leakage. Remove control valve. Inspect or replace gasket.
	Stuck PPC valve.	Remove end cover to inspect modulation spool and check torque on cap screws retaining control valve to transmission.
Transmission system pressure is low (one or two gears)	Failed transmission pump.	Do pump flow test.
	Failed transmission control valve gasket.	Inspect transmission control valve for external leakage. Remove control valve. Inspect or replace gasket.
	Leakage in clutch piston or seal ring.	Disassemble and repair.
Transmission shifts too low	Low oil level (aeration of oil).	Add oil.
	Low transmission pressure.	Do transmission system pressure test.
	Restricted transmission pump suction screen.	Remove and clean screen.
	Low transmission pump flow.	Do transmission pump flow test.
	Excessive transmission element leakage.	Do transmission element leakage test using system pressure.
	Stuck PPC valve.	Remove end cover to inspect modulation spool. Replace if necessary.
	Restricted PPC valve orifice.	Remove orifice and inspect for contamination and /or plugging.
	Restricted oil passages between control valve and transmission elements.	Remove control valve and inspect oil passage.
Incorrect transmission oil.	Change oil (SAE 10W-30/15W-40)	

Problem	Cause	Remedy
Transmission shifts too fast	Wrong transmission controller.	Check if transmission controller has been changed
	System pressure too high.	Do transmission system pressure test.
	Stuck PPC valve.	Remove and inspect PPC valve. Replace if necessary. Also remove end cover to inspect PPC valve and control valve housing. Replace if necessary.
	Stuck or missing check valves.	Inspect transmission control valve.
	Missing O-ring from end of modulation orifice.	Remove orifice and inspect port for O-ring.
	Broken piston return spring.	Disassemble and inspect clutch.
	Incorrect transmission oil.	Change oil (SAE 10W-30/15W-40).
Machine "creeps" in neutral	Warped disks and plates in transmission.	Check transmission.
Transmission hydraulic system overheats	High oil level.	Transmission overfilled or hydraulic pump seal leaking.
	Low oil level.	Add oil.
	Wrong oil grade.	Change oil.
	Park brake dragging.	Check for heat in park brake area.
	Pinched, restricted or leaking lube lines.	Check cooler lines.
	Machine operated in too high gear range.	Operate machine in correct gear range.
	Malfunction in temperature gauge or sensor.	Install temperature sensor the verify temperature. Do tachometer/temperature reader installation procedure.
	Restricted air flow through oil cooler or radiator.	Do radiator air flow test.
	Failed oil cooler bypass valve (In thermal bypass valve).	Disassemble and inspect.
	Failed thermal bypass valve.	Remove thermal bypass valve and check to see if machine still overheats. Do transmission oil cooler thermal bypass valve test.
	Internally restricted oil cooler.	Do oil cooler restriction test.
Leakage in transmission hydraulic system.	Do transmission system pressure, element leakage test.	
Malfunction in converter relief valve.	Do converter out pressure test.	
Low transmission pump output.	Do transmission pump flow test.	

Problem	Cause	Remedy
Excessive transmission noise (Under load or no load)	Too low engine low idle. Worn parts or damaged in transmission. Warped drive line between engine and torque converter. Low or no lube.	Check engine low idle speed. Remove transmission suction screen. Inspect for metal particles. Repair as necessary. Inspect drive line. Do converter-out and lube pressure test. Do transmission pump flow test.
Foaming oil	Incorrect type of oil. High oil level. Low oil level. Air leak on suction side of pump.	Change oil. Transmission overfilled or hydraulic pump seal leaking. Add oil. Check oil pickup tube on side of transmission.
Oil ejected from dipstick	Plugged breather.	Inspect breather on top of transmission. Replace.
Machine vibrates	Aerated oil. Low engine speed. Failed universal joints on transmission drive shaft or differential drive shafts.	Add oil. Check engine speed. Check universal joints.
Machine lacks power and acceleration	Engine high idle speed set too low. Incorrect transmission oil. Aerated oil. Low transmission pressure. Warped transmission clutch. Torn transmission control valve gasket. Brake drag. Failed torque converter. Low engine power.	Check high idle adjustment. Change oil. Add oil. Do transmission system pressure test. Do transmission clutch drag checks. Inspect gasket. Do brake drag check. Do torque converter stall speed test. Do engine power test.
Torque converter stall RPM too high	Aerated oil. Stuck open converter relief valve. Leakage in torque converter seal. Torque converter not transferring power (Bent fins, broken starter).	Put clear hose on thermal bypass outlet port. Run machine to check for bubbles in oil. Do converter-out pressure test. Do converter-out pressure test. Replace torque converter.



Problem	Cause	Remedy
Torque converter stall RPM too low	Low engine power. Mechanical malfunction.	Do engine power test. Remove and inspect torque converter.
Transmission pressure light comes ON when shifting from forward to reverse (all other gears OK)	Low oil level. Cold oil. Leak in reverse pack.	Add oil. Warm oil to specification. Do transmission pressure, pump flow, and leakage check.
Transmission pressure light comes ON for each shift	Cold oil. No time delay in monitor. Restriction in modulation orifice. Stuck PPC valve. Low transmission pressure circuit. Leak in transmission pressure circuit. Failed transmission pump. Clogged filter.	Warm oil to specification. Do monitor check. Remove orifice and inspect for restriction and/or plugging. Remove and inspect. Do transmission system pressure test. Do converter out pressure test. Do transmission pump flow test. Inspect filter. Replace.

## 2) DIFFERENTIAL / AXLE

Problem	Cause	Remedy
Differential low on oil	External leakage.	Inspect axle and differential for leaks.
Excessive differential and/or axle noise	Low oil level in differential.  Incorrect type of oil.  Dragging brakes.  Failed pinion bearing.  Incorrect gear mesh pattern between ring and pinion gear.  Failed differential pinion gears and/or cross shafts.  Failed axle bearing.  Mechanical failure in axle planetary.	Check oil. Remove drain plug and inspect for metal particles in differential case. Disassemble and determine cause.  Change oil  Do brake check.  Remove and inspect pinion. Check to ensure pinion housing was indexed.  Remove pinion gear housing and inspect ring and pinion gear.  Remove differential housing drain plug and inspect for metal particles. Disassemble and inspect.  Do axle bearing adjustment check.  Remove differential. Inspect, repair.
Oil seeping from outer axle seal	Excessive end play in axle.  Worn outer bearing and/or cup.  Overfilled differential.	Do axle bearing adjustment check.  Disassemble and inspect outer axle bearing, cup, spacer, and seal. Replace, if necessary.  Check differential oil return system for excessive internal restriction.
Axle overheats	Low differential oil.  Overfilled differential.  Brake drag.	Add oil.  See differential overfills with oil in this group.  See brakes drag in this group.

### 3) DRIVE LINE

Problem	Cause	Remedy
Excessive drive line vibration or noise	Yokes not in line on drive shafts.	Inspect. Align drive shaft yokes.
	Worn front drive line support bearing.	Inspect, repair.
	Bent drive shaft.	Inspect all drive shafts. Replace.
	Loose yoke retaining nuts (drive shafts wobble at high speed).	Inspect. Replace.
	Rear axle oscillating support.	Inspect, repair.
	Lack of lubrication.	Lubricate with proper grade of grease.

## GROUP 3 TESTS AND ADJUSTMENTS

### 1. TRANSMISSION MEASURING POINTS AND CONNECTIONS

The measurements have to be carried out at hot transmission (about 80-95°C).

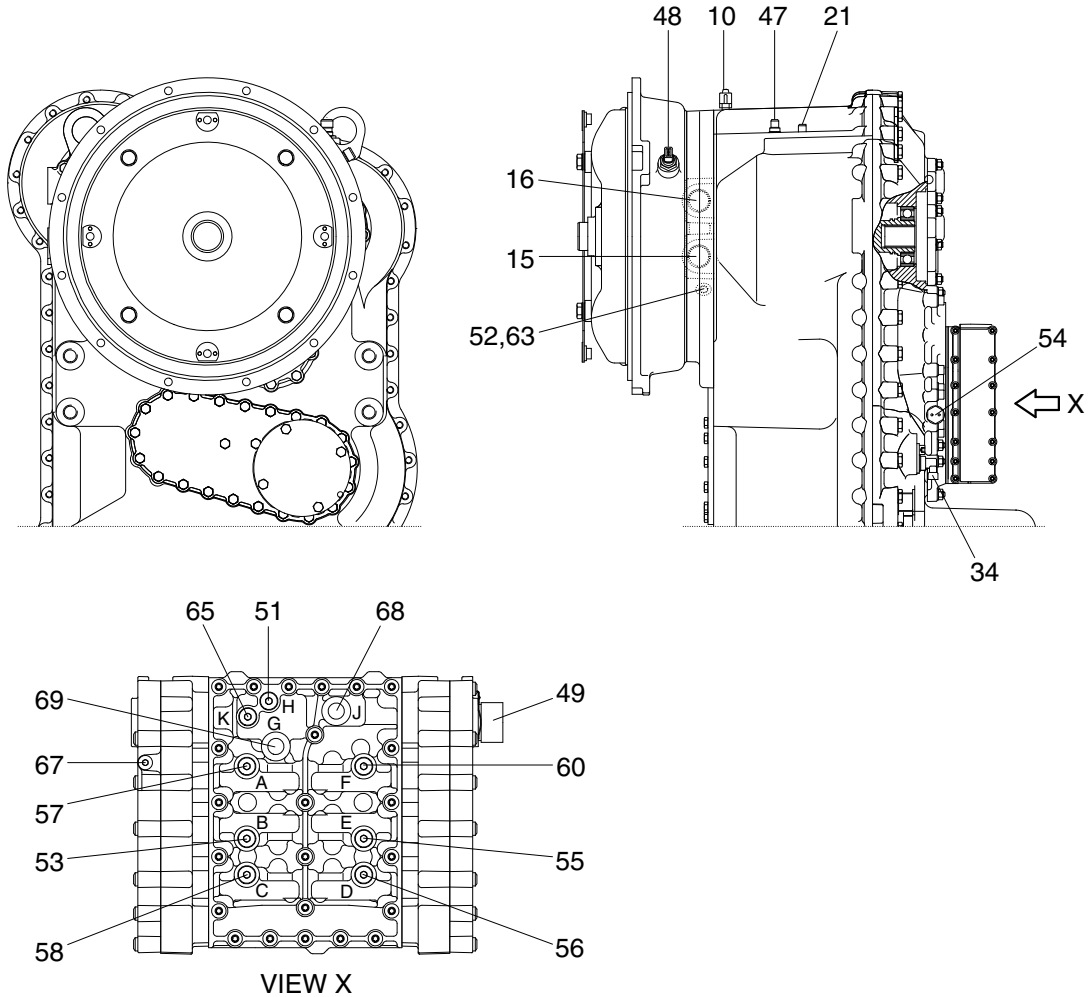

955SA3PT14

#### 1) OIL PRESSURE AND TEMPERATURE

Port	Description		Size
51	Converter inlet-opening pressure (11+2 bar)	H	M10×1.0
52	Converter outlet-opening pressure (4.3+3 bar)		M14×1.5
53	Forward clutch (16+2 bar)	KV B	M10×1.0
55	Reverse clutch (16+2 bar)	KR E	M10×1.0
56	1st clutch (16+2 bar)	K1 D	M10×1.0
57	2nd clutch (16+2 bar)	K2 A	M10×1.0
58	3rd clutch (16+2 bar)	K3 C	M10×1.0
60	4th clutch (16+2 bar)	K4 F	M10×1.0
63	Converter outlet temperature 100°C, short-time 120°C		M14×1.5
65	System pressure (16+2 bar)	K	M10×1.0

## 2) DELIVERY RATES

Port	Description	Size
15	Connection to the oil cooler	1 5/6" -12UNF-2B
16	Connection from the oil cooler	1 5/6" -12UNF-2B

## 3) INDUCTIVE TRANSMITTER AND SPEED SENSOR

Port	Description	Size
21	Inductive transmitter n turbine	M18 × 1.5
34	Speed sensor n output and speedometer	-
47	Inductive transmitter n central gear train	M18 × 1.5
48	Inductive transmitter n engine	M18 × 1.5
54	Filter contamination switch	M14 × 1.5

## 4) CONNECTIONS

Port	Description	Size
10	Breather	M10 × 1.0
49	Plug connection on the hydraulic control unit	-
68	Pilot pressure (option) J	M16 × 1.5
69	System pressure (option) G	M16 × 1.5

## GROUP 4 DISASSEMBLY AND ASSEMBLY

### 1. TRANSMISSION

#### 1) DISASSEMBLY

##### Electro-hydraulic control and fine filter

※ Attach transmission to assembly truck.

Assembly truck                    5870 350 000

Holding fixtures                5870 350 063

Clamping angles                5870 350 090

※ Drain oil prior to starting disassembly.

※ Disposal of oil according to legal requirements.

#### (1) Removal of filter

① Separate fine filter (1) from filter head by means of belt wrench.

Belt wrench                        5870 105 005

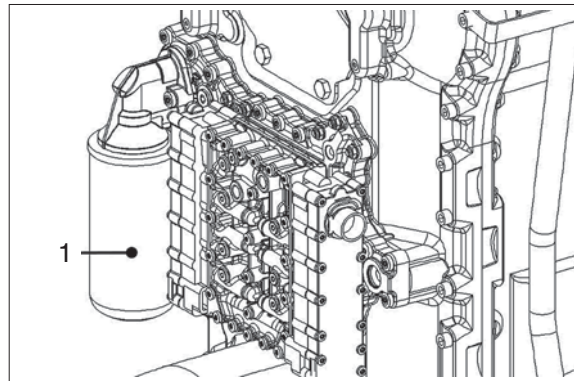

7609ATM002

② Loosen Torx screws (2) and separate filter head (1) from transmission housing.

※ Remove O-rings.

Socket wrench TX 40            5873 042 004

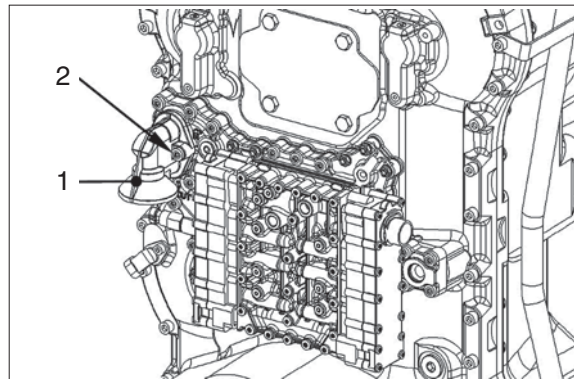

7609ATM003

## (2) Removal of electric gear-shift control

- ① Remove gear-shift control (1).

Loosen Torx screws (2) and separate gear-shift control housing from intermediate plate.

Socket wrench TX-27      5873 042 002  
Adjusting screws M6      5870 204 063

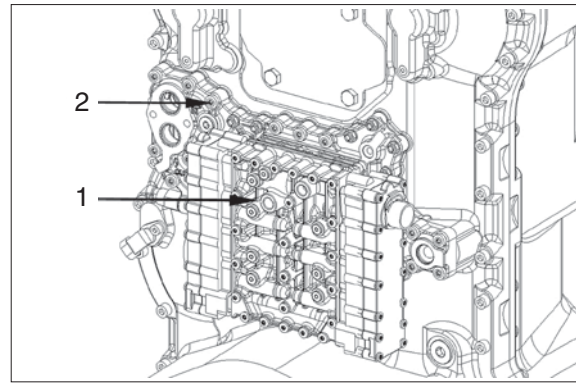

7609ATM004

- ② Remove gear-shift control assy (1) and sealing plate (2).

Adjusting screws M6      5870 204 063

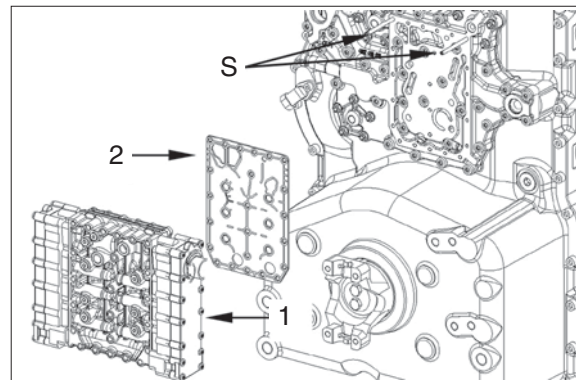

7609ATM005

- ③ Remove differential pressure switch for fine filter from duct plate (4).

- 1 Switch with O-ring
- 2 Piston
- 3 Compression spring

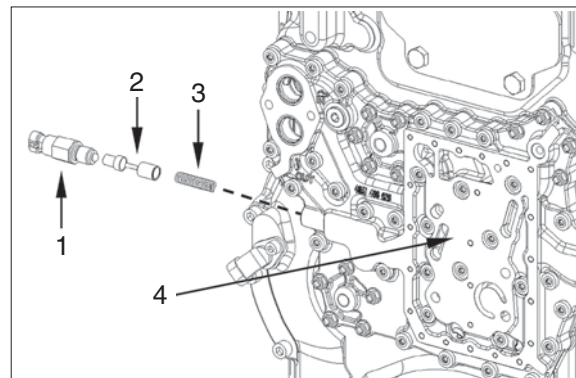

7609ATM006

- ④ Loosen hexagon nuts and Torx screws and separate duct plate (1) and seal (2) from housing rear part.

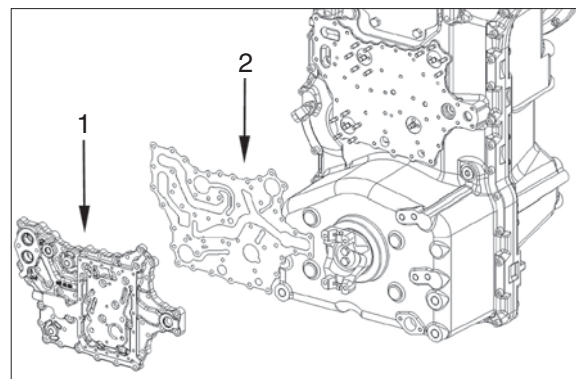

7609ATM007



- ⑤ Pull converter safety valve (1) out of housing hole.

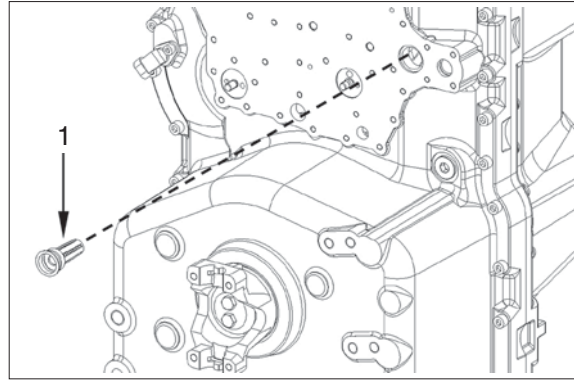

7609ATM008

- ⑥ Mark installation position of wiring harness (1) towards valve block (2).

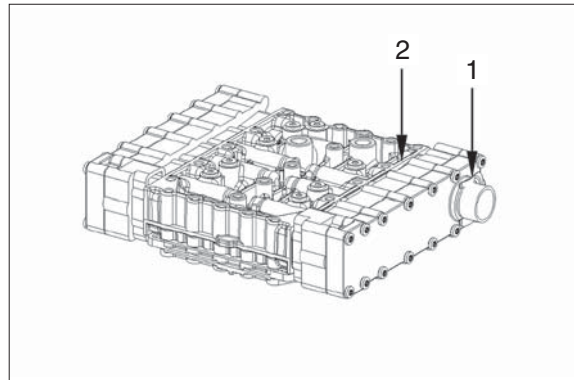

7609ATM009

- ⑦ Loosen Torx screws (1).

Socket wrench TX-27      5873 042 002

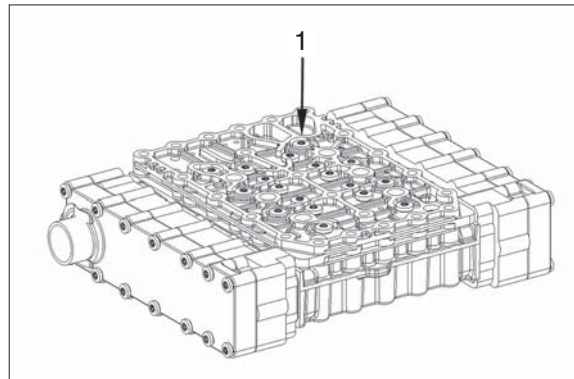

7609ATM010

- ⑧ Separate duct plate (1) and sealing plate (2) from valve block (3).

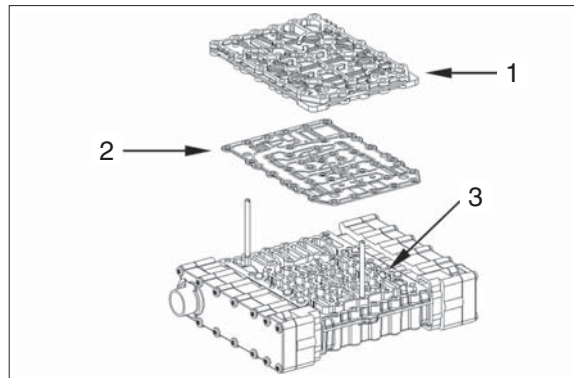

7609ATM011

- ⑨ Remove retaining clamp (1).

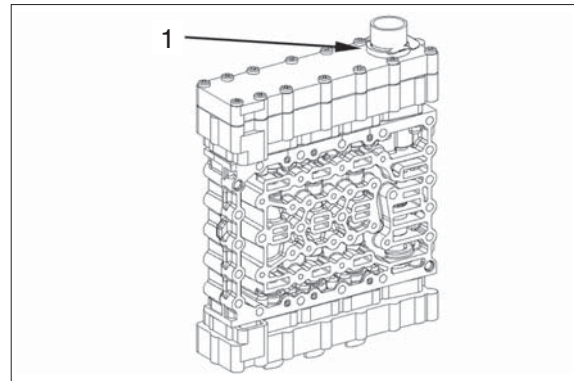

7609ATM012

- ⑩ Loosen Torx screws (1) and remove cover (2).  
Remove opposite cover (3) in the same way.

Socket wrench TX-27      5873 042 002

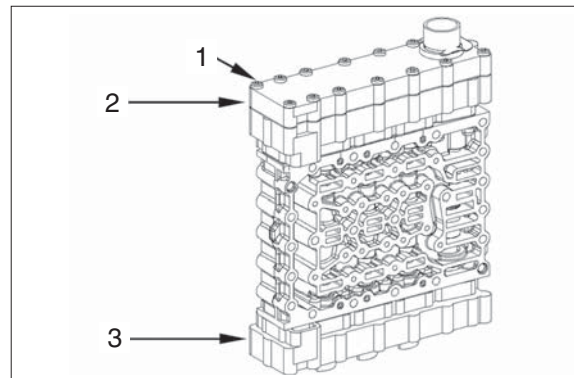

7609ATM013

- ⑪ Remove wiring harness (1).

Loosen cylindrical screws (3), remove fixing plates and remove pressure controllers (2).

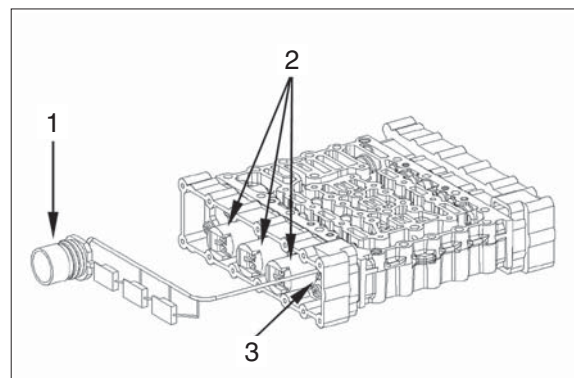

7609ATM014

- ⑫ Loosen cylindrical screws, remove fixing plates and remove pressure controllers (1) on opposite side.

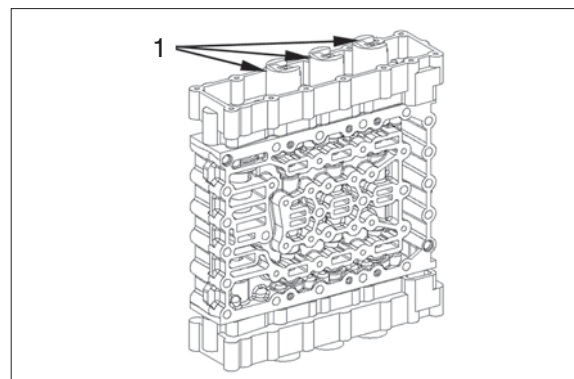

7609ATM015

- ⑬ Loosen two Torx screws (1) and preliminarily fix housing by means adjusting screws. (Housing is spring-loaded) Then loosen remaining Torx screws.

Adjusting screws (s)      5870 204 036

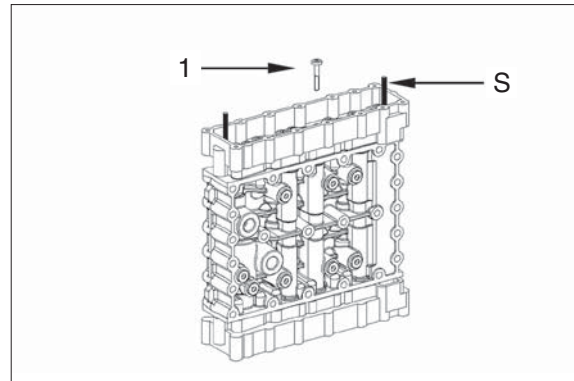

7609ATM016

- ⑭ Separate housing from valve housing by loosening the adjusting screws equally.

Adjusting screws      5870 204 036

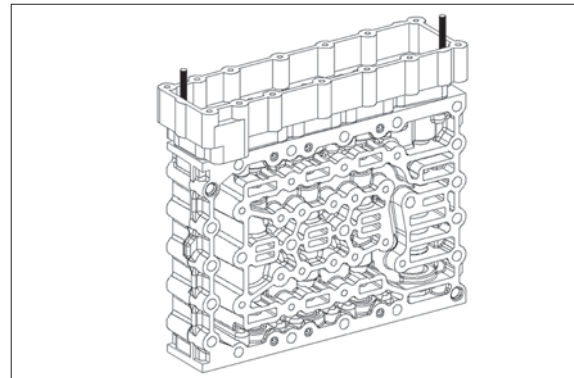

7609ATM017

- ⑮ Remove individual parts :
- 1 Pressure reducing valve
  - 2 Vibration dampers
  - 3 Follow-on slide

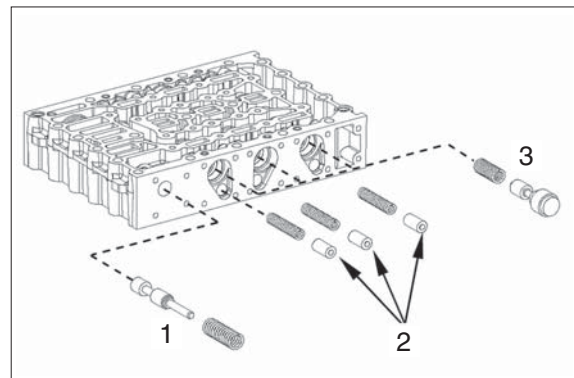

7609ATM018

- ⑩ Remove individual parts of opposite side analogously :
- 1 Main pressure valve
  - 2 Vibration dampers
  - 3 Follow-on slide

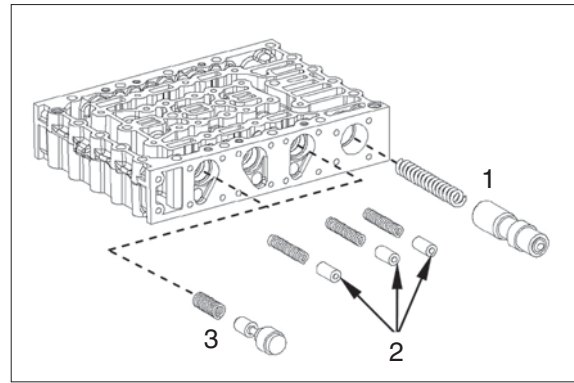

7609ATM019

## 2) DISASSEMBLY

**Inductive sensor, hall sensor, breather, oil filler and oil drain plug.**

(1) Attach transmission to assembly truck.

Assembly truck	5870 350 000
Holding fixtures	5870 350 063
Clamping angles	5870 350 090

(2) Remove positioned parts.

- 1 Screw plug (oil drain hole)
- 2 Oil filler tube with oil dipstick
- 3 Breather
- 4 Inductive sensor - n central gear chain
- 5 Inductive sensor - n turbine
- 6 Inductive sensor - n engine

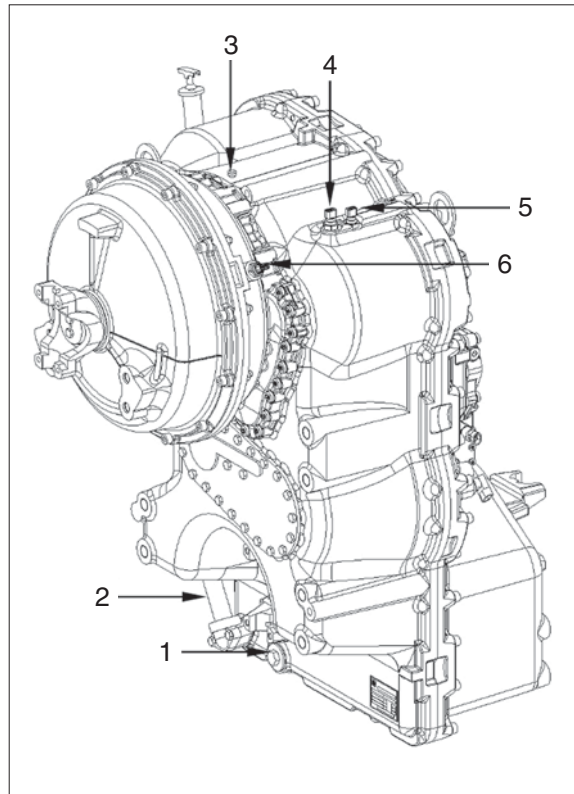

7609ATM021

(3) Loosen cylindrical screw (1) and remove speed sensor (hall sensor).

※ Remove O-ring.

- 2 Speed sensor - n output

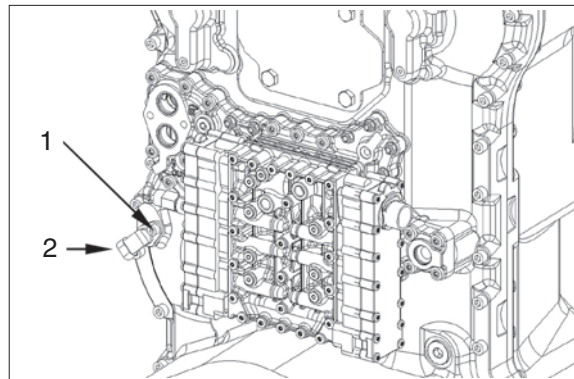

7609ATM022

### 3) DISASSEMBLY

Engine connection, oil pressure pump, converter back-pressure valve and temperature sensor (measuring point "63" after the converter).

#### (1) Engine connection

- ① Loosen hexagon screw (2) and separate flexplate (1) from converter (3).

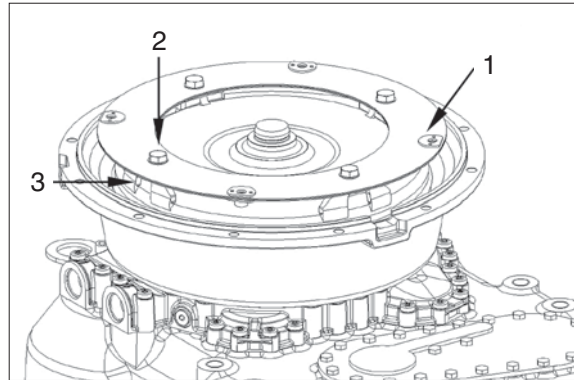

7609ATM023

- ② Separate converter (1) from transmission by means of lifting device.

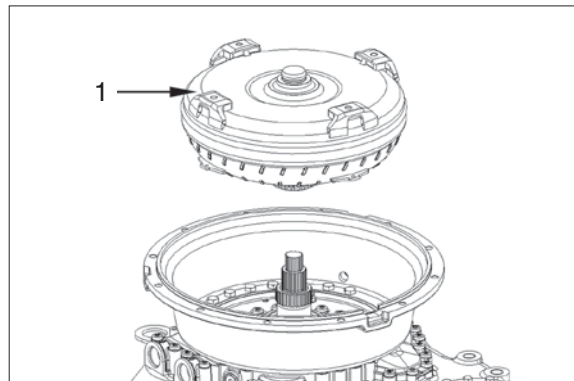

7609ATM024

#### (2) Oil pressure pump

- ① Loosen bolted connection (1) converter bell housing/oil feed housing and remove converter bell housing (2).

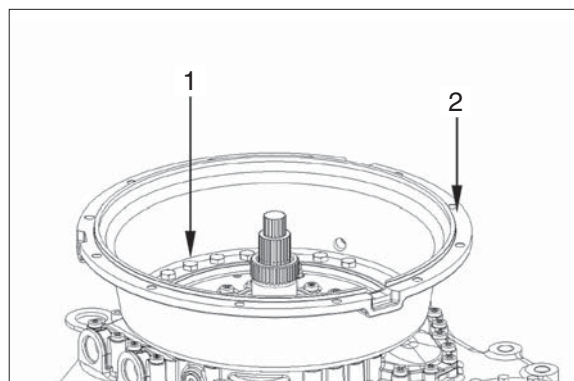

7609ATM025

- ② Loosen bolted connection (1) oil feed housing/transmission housing front part with torx screws and bolted connection (2) oil pressure pump/transmission housing front part with cylindrical screws.

※ Separate oil feed housing together with oil pressure pump from transmission housing front part.

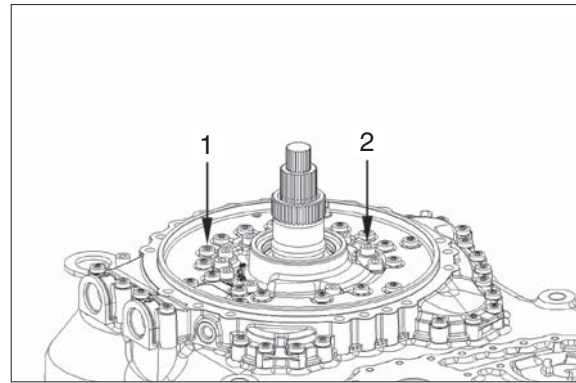

7609ATM026

- ③ Separate oil pressure pump (1) from oil feed housing (2).

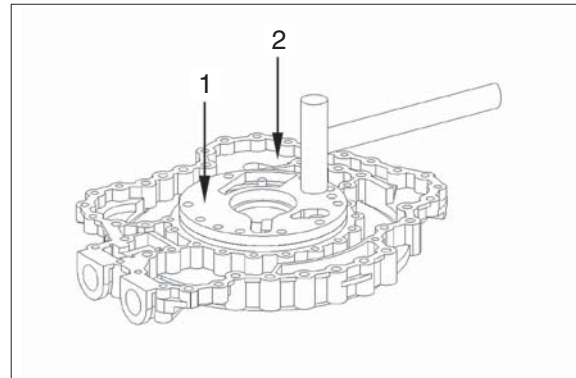

7609ATM027

- ④ Remove O-ring (1).

※ Loosen cylindrical screws (2).

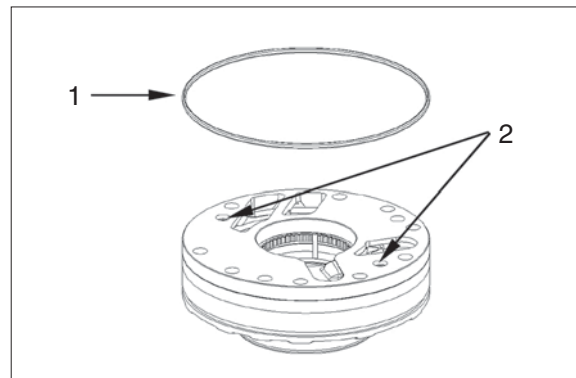

7609ATM028

※ Check oil gear pump :

In case of wear marks in the pump housing, cover or on the inner and outer rotor, the complete oil pressure pump is to be replaced.

- 1 Cover
- 2 Inner rotor
- 3 Outer rotor
- 4 Pump housing

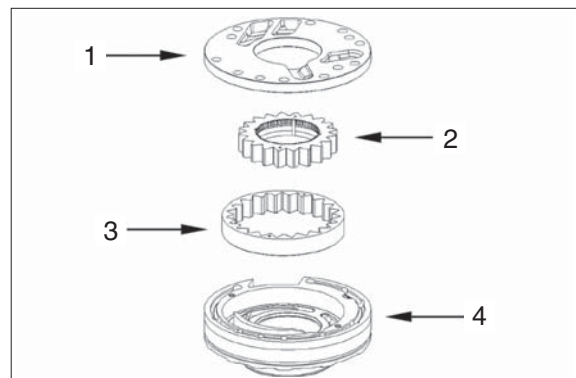

7609ATM029



- ⑤ Remove shaft seal (1) from the pump housing (2).

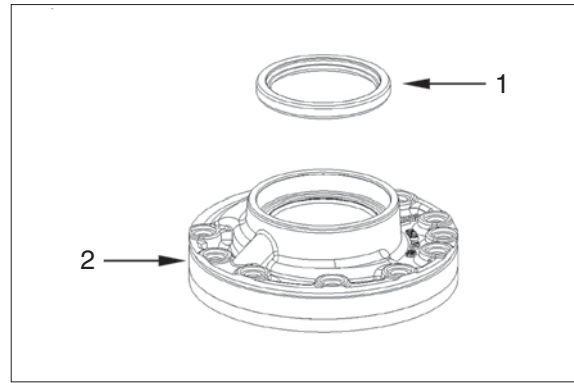

7609ATM030

### (3) Converter back-pressure valve

- ① Preload converter safety valve (1) by means of screw driver or assembly aid and remove locking plate (2).

Assembly aid                      5870 345 107

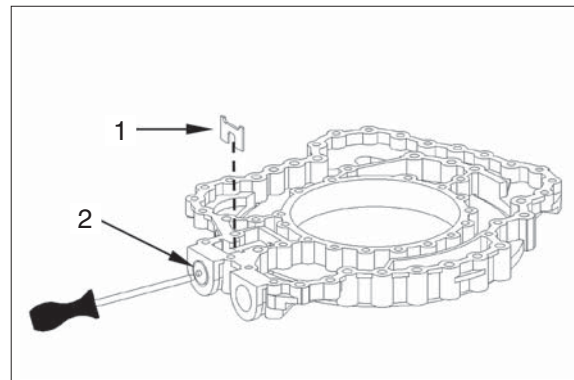

7609ATM031

- ② Remove individual parts of converter safety valve which are getting released.

- 1 Pressure plate
- 2 Compression spring
- 3 Piston

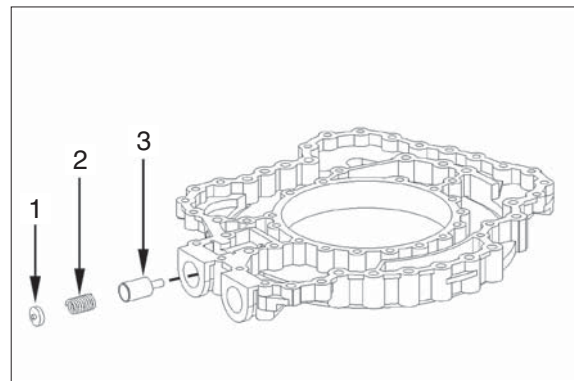

7609ATM032

- ③ Remove temperature sensor (1).

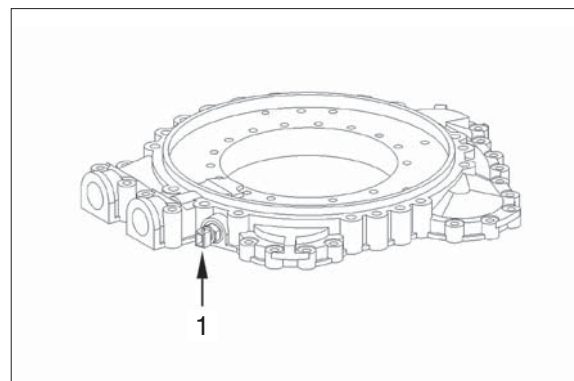

7609ATM033



④ Remove stator shaft (1).

Pull pressure relief valve (2) out of the housing hole.

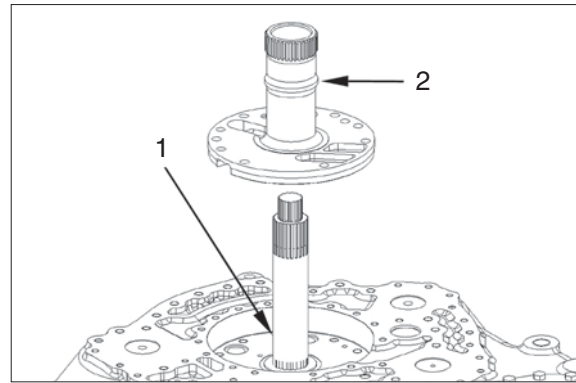

7609ATM034

#### 4) DISASSEMBLY

##### Without emergency steering pump

Loosen bolted connection cover (1) and cover front part (2) and remove cover (3 and 4) and seal.

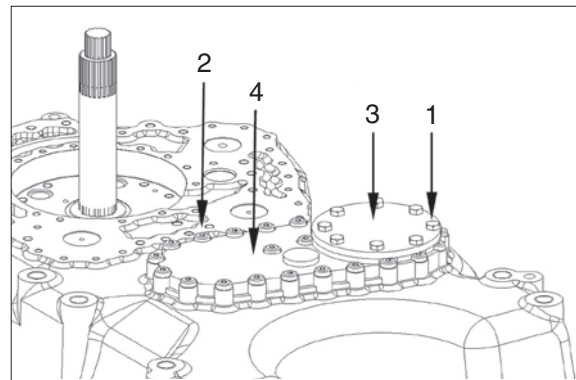

7609ATM035

## 5) DISASSEMBLY

### Outputs flange

#### (1) Output flange on converter side

- ① Loosen hexagon screws (1), remove washer and O-ring.

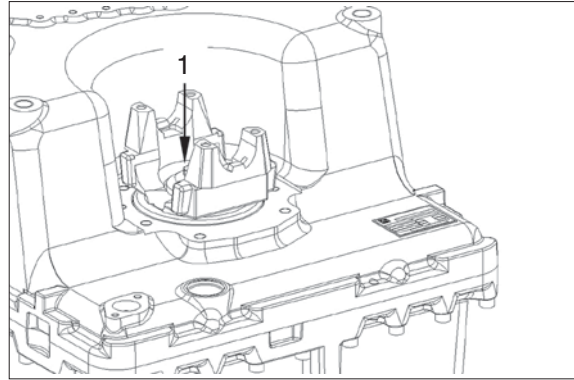

7609ATM036

- ② Pull off output flange (1) and remove shaft seal (2).

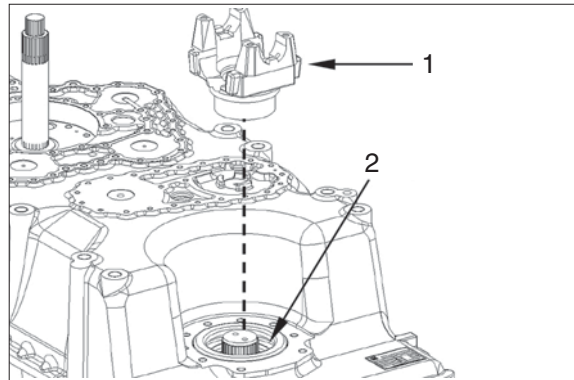

7609ATM037

#### (2) Output flange on output side

- ① Loosen hexagon screws (1), remove washer and O-ring.

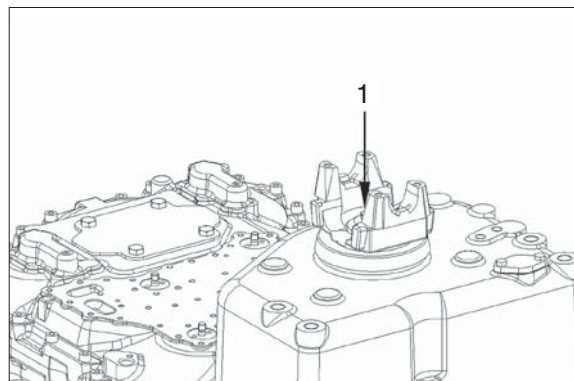

7609ATM038

- ② Pull off output flange (1) and remove shaft seal (2).

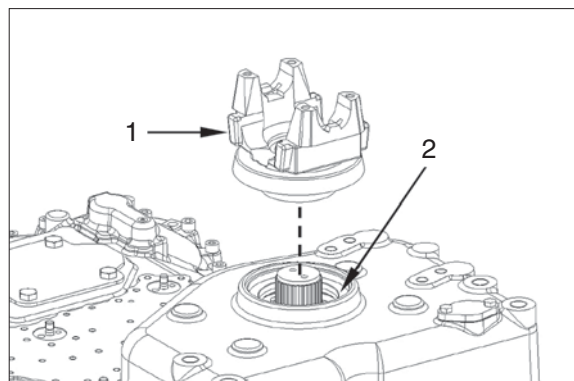

7609ATM039

**(3) Output flange on output side with parking brake**

- ① Connect HP pump at port (see arrow) and apply approx. 80 bar pressure to the hydraulically actuated parking brake (1) until the brake disc (2) can be rotated by hand.

HP hand-operated pump 5870 287 007  
MINIMESS coupling (M12 × 1.5)  
5870 950 101

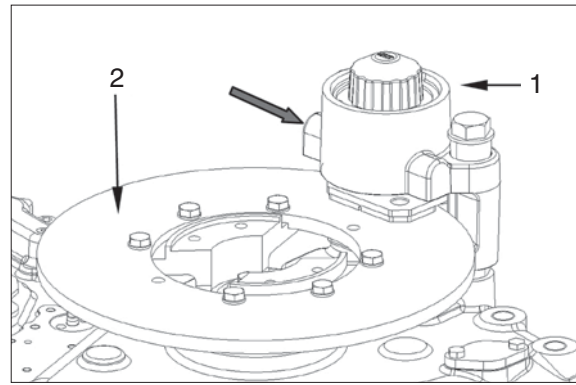

- ② Loosen hexagon nut with open end wrench insert.

Open end wrench insert AA00 244 432

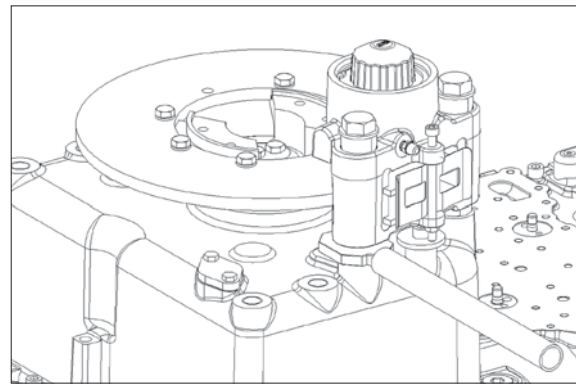

- ③ Loosen hexagon screws (2) and remove parking brake (1) (see figure TM043).

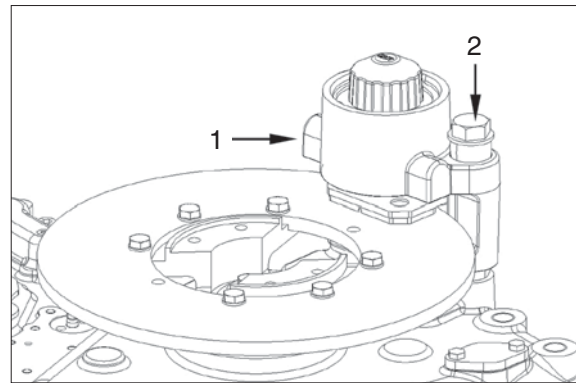

- ④ Loosen hexagon screws (2) of bolted brake disk/output flange connection and remove brake disk (3).

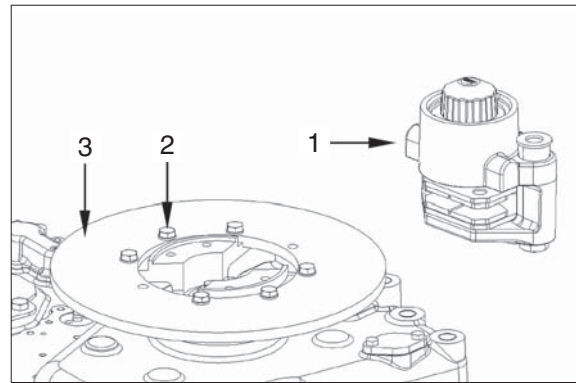

⑤ Loosen hexagon screws (1), remove washer and O-ring.

Pull-off output flange (2) and remove shaft seal.

Remove cylindrical screw with washer (3).

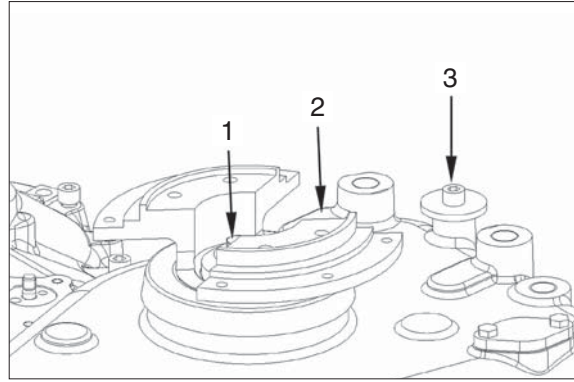

7609ATM044

**6) REMOVAL OF INPUT SHAFT, OUTPUT SHAFT, PUMP SHAFT (PTO-SHAFT) AND CLUTCHES**

(1) Force out both cylindrical pins (1).

Loosen bolted connection (2) between housing front and rear part and separate housing rear part by means of lifting device.

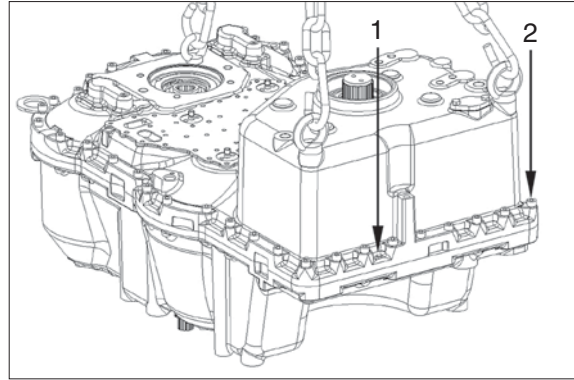

7609ATM045

(2) Loosen bolted connection (1) of oil screen sheets.

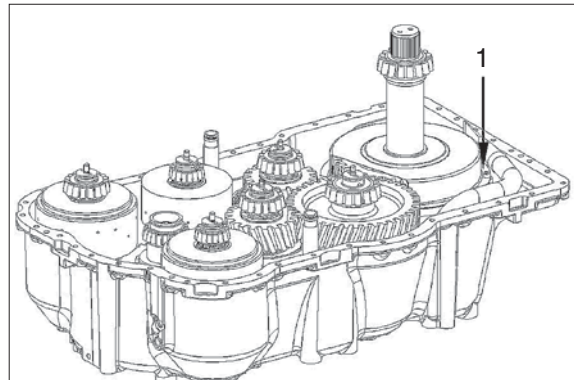

7609ATM046

(3) Remove output shaft (1) and lower oil screen sheet (2) from housing.

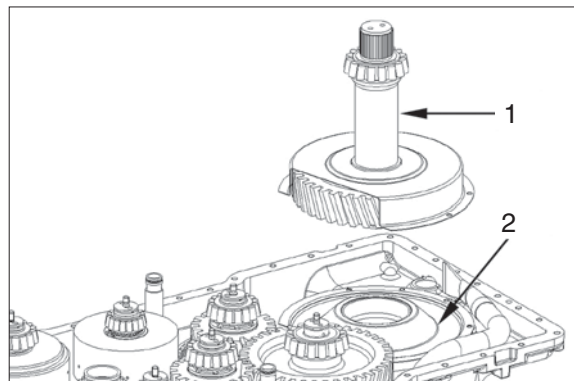

7609ATM047

(4) Remove all rectangular rings (1) from the clutches and all O-rings (2) from the oil tubes.

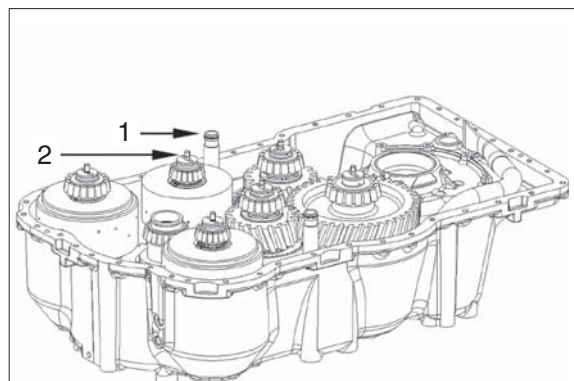

7609ATM048

- (5) Use lifting device to bring housing rear part (1) into contact position with housing front part (2) again.

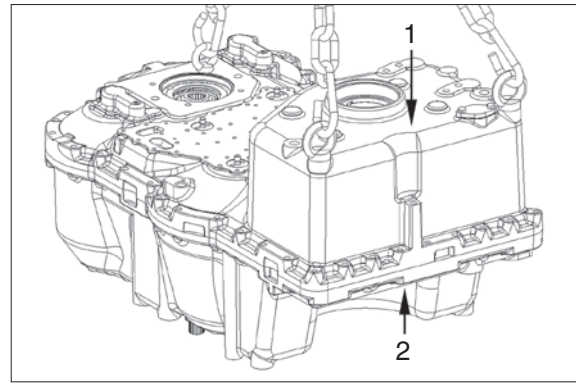

7609ATM049

※ Due to the installation conditions, the removal of single clutches without using the special tool is not possible.

- (6) Fix all clutches K1, K2, K3 and K4 by means of handle (1).

Handle 5870 260 010

※ Clutches KV, KR and input shaft (2) are only fixed by the gear chain.

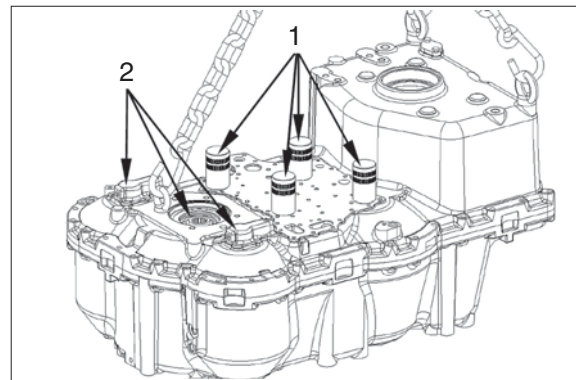

7609ATM050

- (7) Separate housing rear part incl. clutches from housing front part by means of the lifting device and attaches it to the assembly truck.

- 1 Clutch KV
- 2 Input shaft
- 3 Clutch KR
- 4 Pump shaft

※ Clutches KV, KR and input shaft are only fixed by the gear chain.

Attention must be paid that the non-fixed components of the gear chain do not get loose.

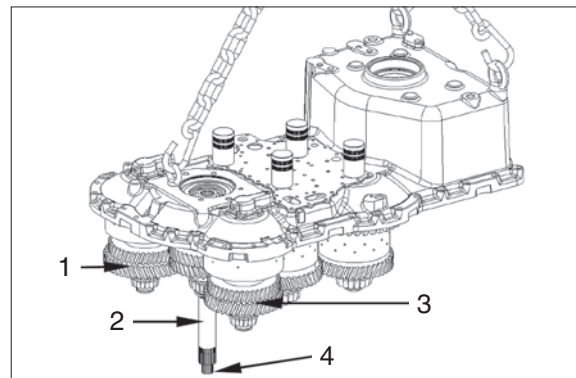

7609ATM051

- (8) Loosen cylindrical screws of oil tubes (1) in the housing front part and remove them.

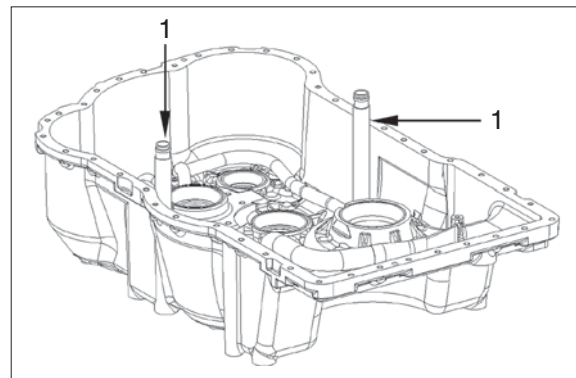

7609ATM052

※ The suction tube (1) and the lubrication lines (2) are rolled in and are highly difficult to remove.

In case of damage, use of the appropriate special tool is imperative for fitting or replacing these components.

Rolling tool 5870 600 003

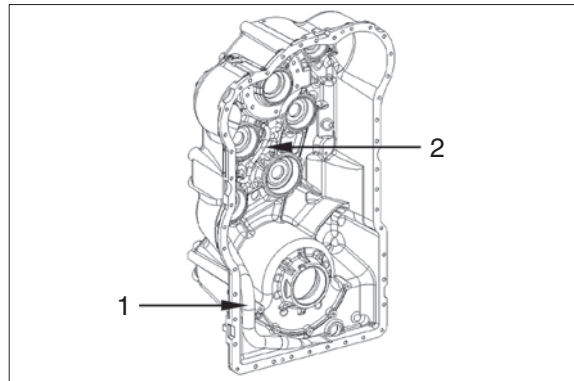

7609ATM053

(9) Remove bearing outer rings (arrows) from the housing front part.

※ If, contrary to the recommendation, the tapered roller bearings of clutches, input and output are not replaced, it is imperative to ensure the previous pairing (bearing outer ring/ bearing inner ring).

Bearing outer ring and bearing inner ring must be marked.

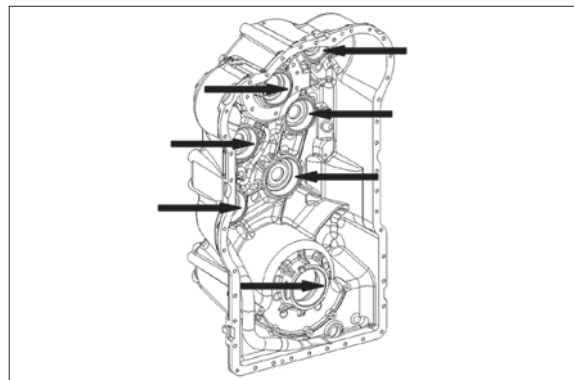

7609ATM054

(10) Disengage retaining ring (1) and remove pump shafts (2).

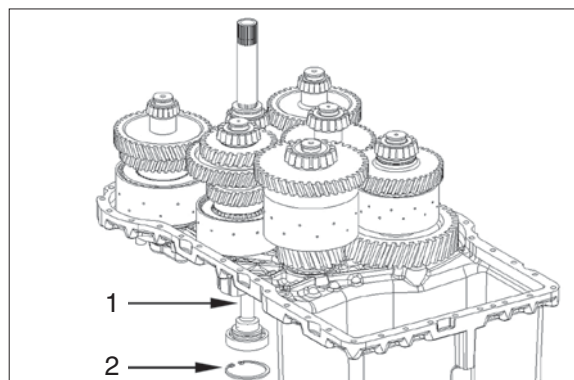

7609ATM055

(11) Press ball bearing (1) off the pump shaft.

Snap out rectangular ring (2).

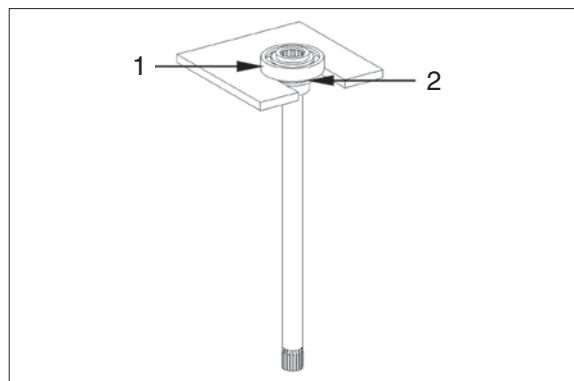

7609ATM056



(12) Lift the clutches out of the housing in numerical order as described in the legend.

- 1 K1 clutch
- 2 K2 clutch
- 3 K3 clutch
- 4 K4 clutch
- 5 KR clutch
- 6 KV clutch
- 7 input shaft

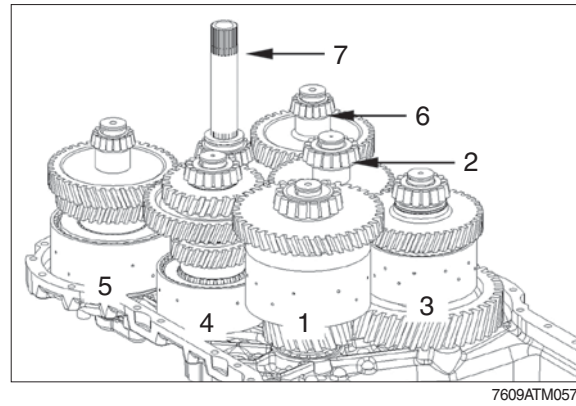

(13) Remove bearing outer rings (arrows) from the housing rear part.

※ If, contrary to the recommendation, the tapered roller bearings of clutches, input and output are not replaced, it is imperative to ensure the previous pairing (bearing outer ring/ bearing inner ring).

Bearing outer ring and bearing inner ring must be marked.

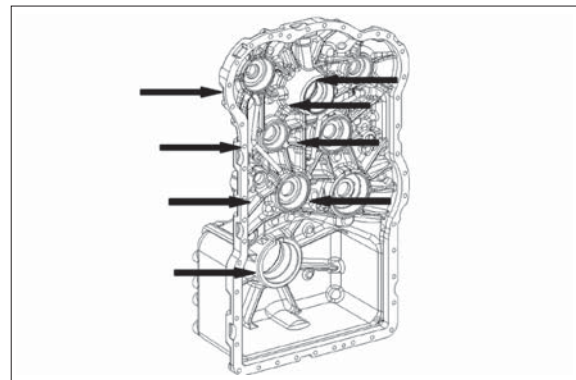

※ The lubrication lines are rolled in (1 and 2) and are highly difficult to remove. In case of damage, use of the appropriate special tool is imperative for fitting or replacing these components.

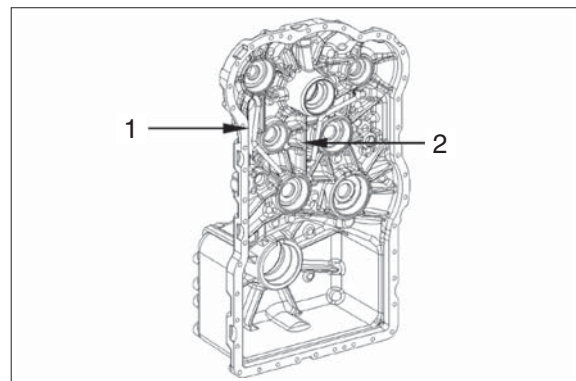



## 7) DISASSEMBLY

### Clutches KV / KR / K1 / K2 / K3 / K4 input and output shaft

See opposite picture.

- K1 clutch
- K2 clutch
- K3 clutch
- K4 clutch
- KR clutch
- KV clutch
- AN input shaft

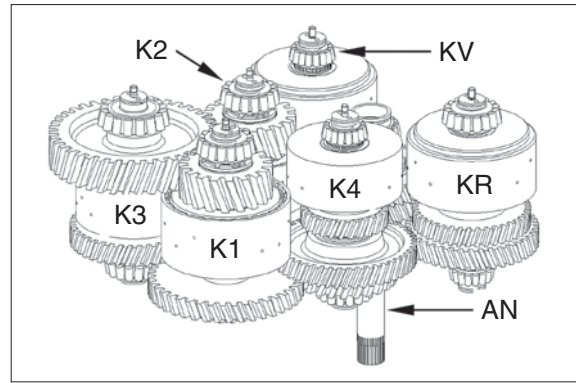

7609ATM060

### (1) KV clutch

- ① Remove stud bolt (1) and snap out piston ring (2).

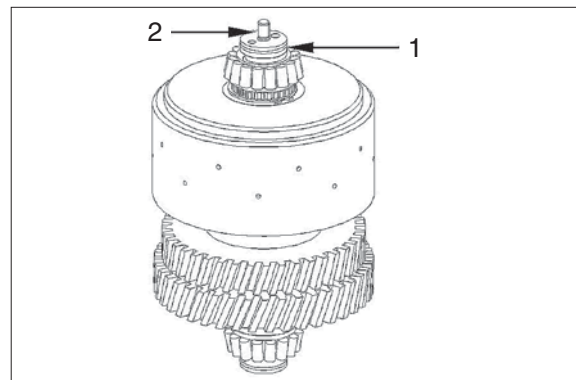

7609ATM061

- ② Pull tapered roller bearing (inner ring) off the shaft.

Forcing device	5870 026 100
Grab sleeve	5873 001 057
or	
Rapid grip	5873 011 011

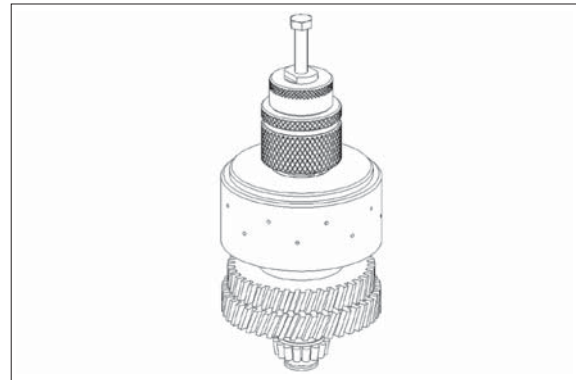

7609ATM062

- ③ Snap out retaining ring (1).

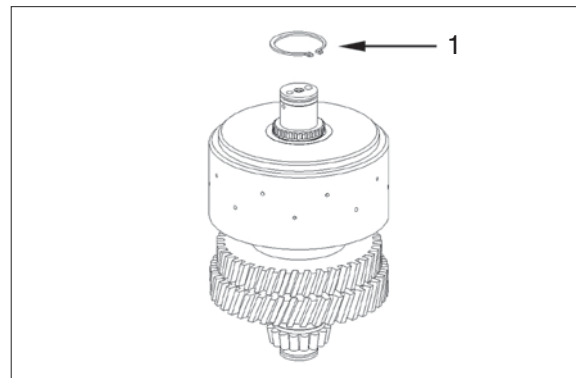

7609ATM063

④ Pull clutch (1) off the shaft.

※ Disassembly clutch (1) see figure TM070~TM075.

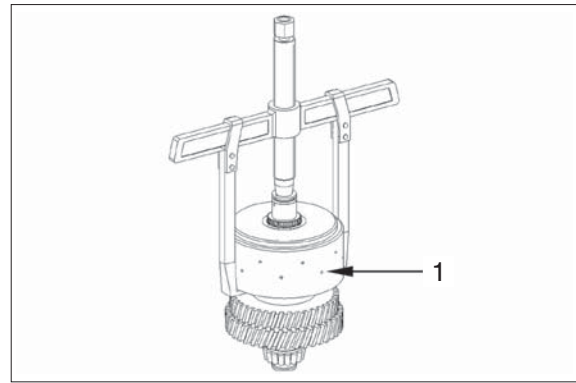

7609ATM064

⑤ Fix idler gear (1) by means of cut-off device and pull it off the clutch shaft.

Cut-off device                    5870 300 024  
Puller                                5870 300 033

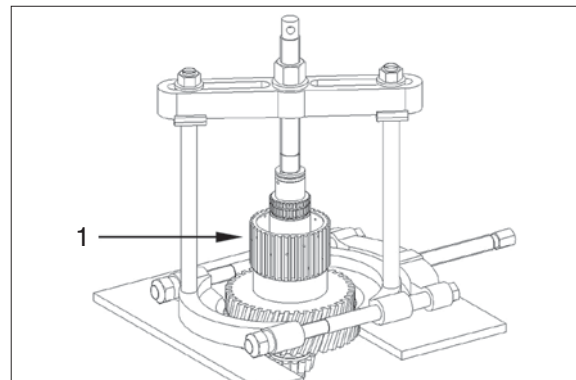

7609ATM065

⑥ Snap retaining ring (2) out of the idler gear (1) and remove ball bearing (3).

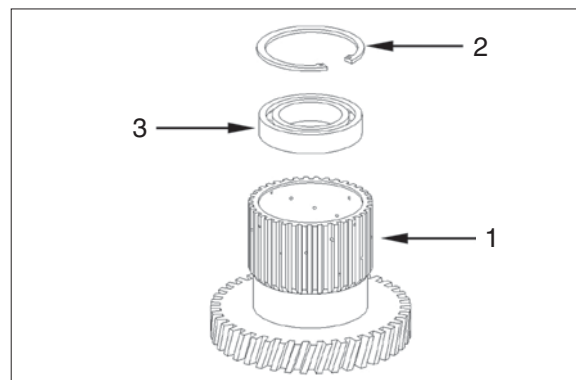

7609ATM066

⑦ Remove needle cage (1) from the shaft (2).

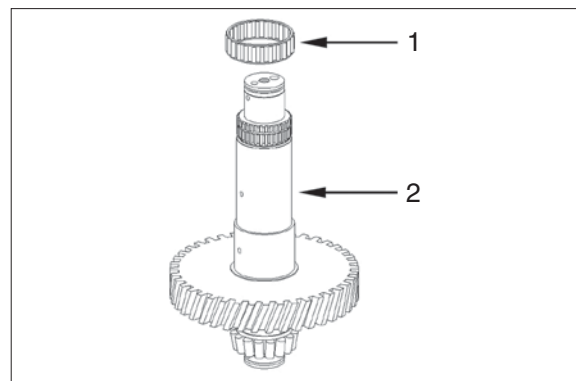

7609ATM067

- ⑧ Turn shaft (2) by 180° and snap out piston ring (1).

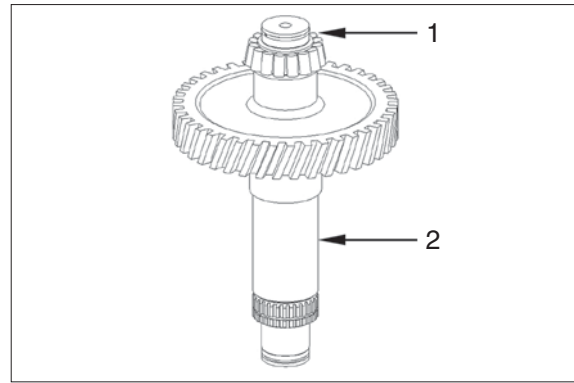

7609ATM068

- ⑨ Pull tapered roller bearing (inner ring) off the shaft.

Forcing device	5870 026 100
Grab sleeve	5873 001 057
or	
Rapid grip	5873 011 011

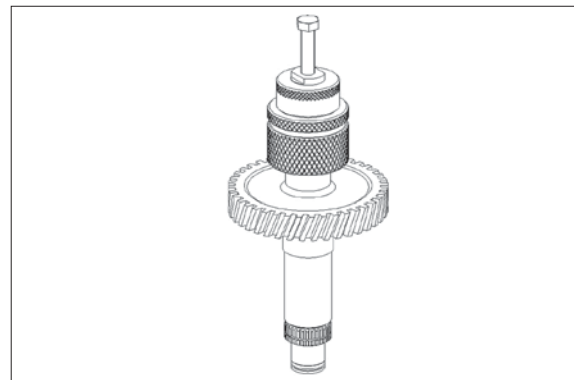

7609ATM069

- ⑩ Unsnap snap ring (1).

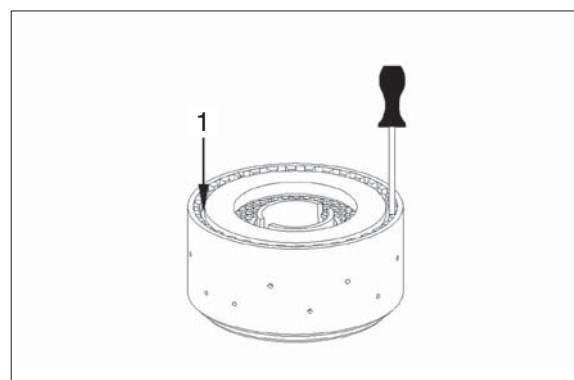

7609ATM070

- ⑪ Remove end shim (1) and disc set (2) out the disc carrier (3).

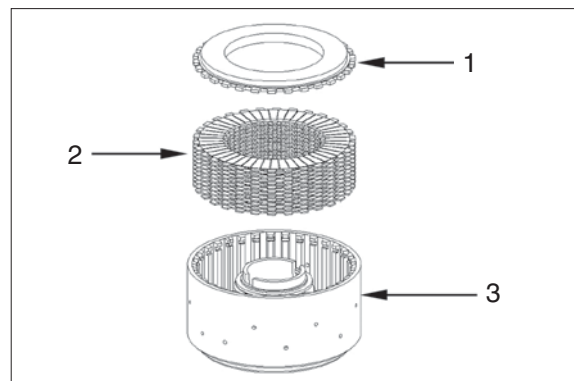

7609ATM071

- ⑫ Preload compression spring (1) unsnap L-ring.

Assembly aid

5870 345 088

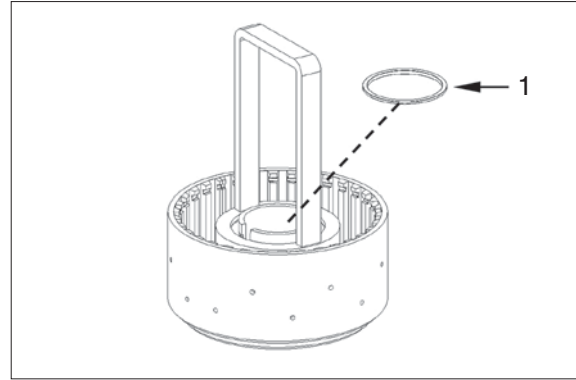

7609ATM072

- ⑬ Remove support shim (1), compression spring (2) and washer (3).

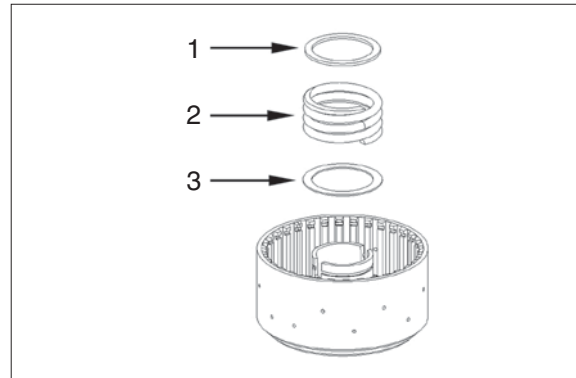

7609ATM073

- ⑭ Lift piston (1) by means of compressed air out of the cylinder bore and remove it.

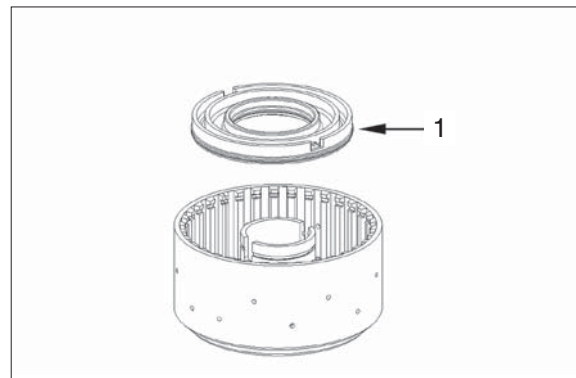

7609ATM074

- ⑮ Remove both O-rings (1 and 2).

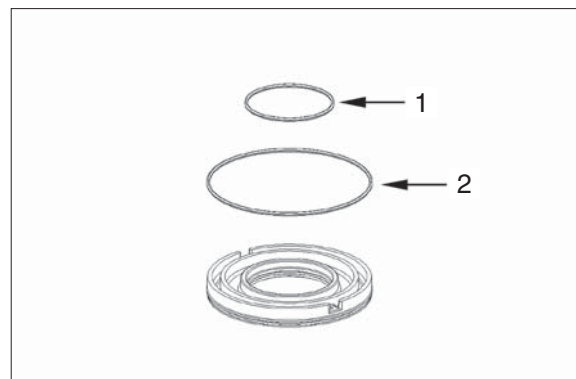

7609ATM075

## (2) KR clutch

- ① Remove stud bolt (1) and snap out piston ring (2).

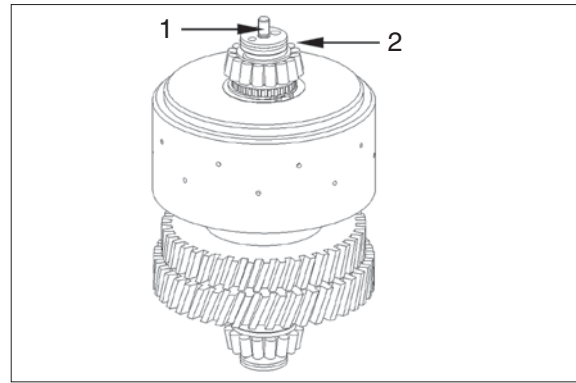

7609ATM076

- ② Pull tapered roller bearing (inner ring) off the shaft.

Forcing device                    5870 026 100  
Grab sleeve                        5873 001 059

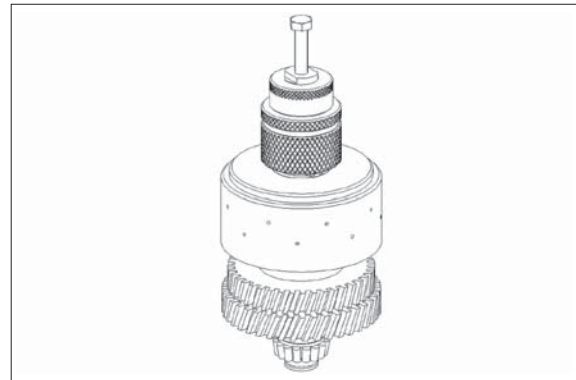

7609ATM077

- ③ Snap out retaining ring (1).

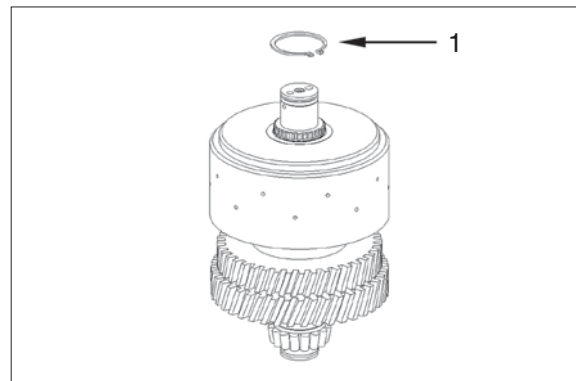

7609ATM078

- ④ Pull clutch (1) off the shaft.

※ Disassembly clutch (1) see figure  
TM085~TM090.

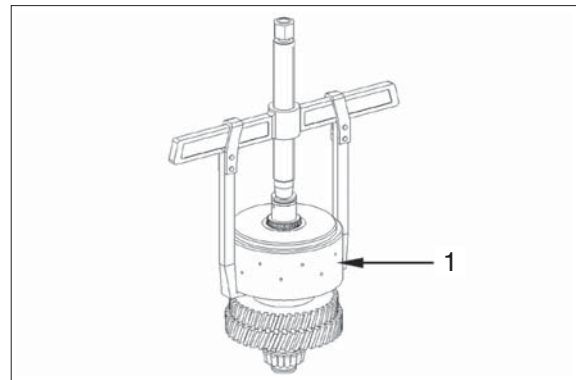

7609ATM079

- ⑤ Fix idler gear (1) by means of cut-off device and pull it off the clutch shaft.

Cut-off device                    5870 300 024  
Puller                                5870 300 033

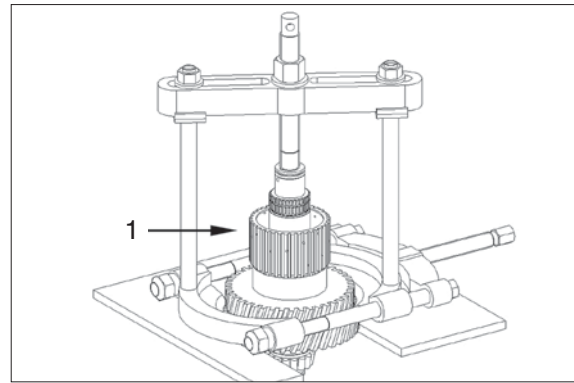

7609ATM080

- ⑥ Snap retaining ring (2) out of the idler gear (1) and remove ball bearing (3).

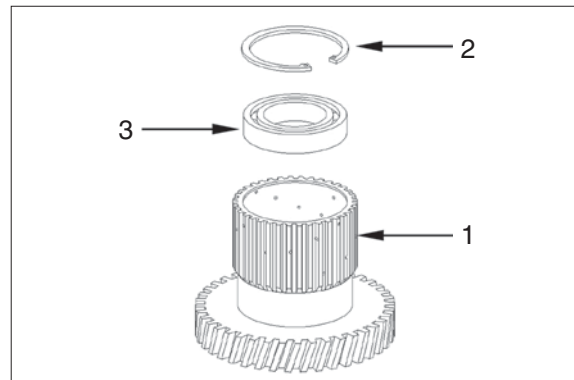

7609ATM081

- ⑦ Remove needle cage (1) from the shaft (2).

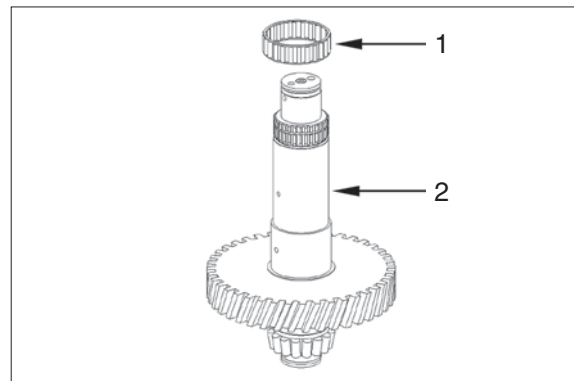

7609ATM082

- ⑧ Turn shaft (2) by 180° and snap out piston ring (1).

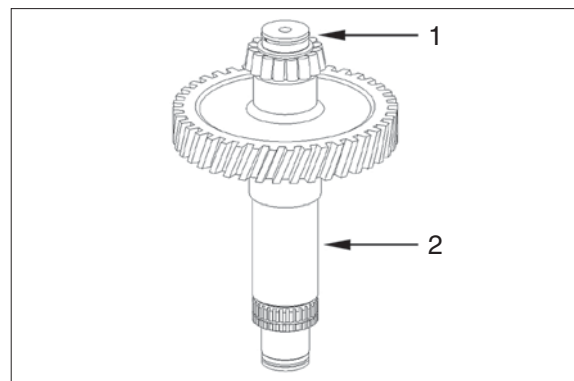

7609ATM083

- ⑨ Pull tapered roller bearing (inner ring) off the shaft.

Forcing device                    5870 026 100  
Grab sleeve                      5873 001 057  
or  
Rapid grip                        5873 011 011

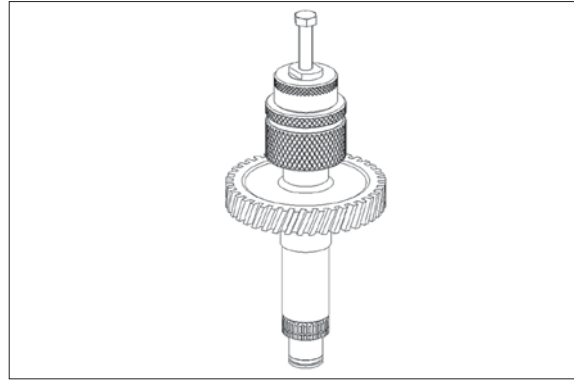

7609ATM084

- ⑩ Unsnap snap ring (1).

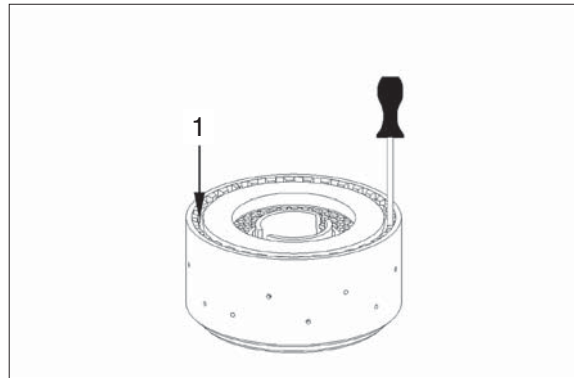

7609ATM085

- ⑪ Remove end shim (1) and disc set (2) out the disc carrier (3).

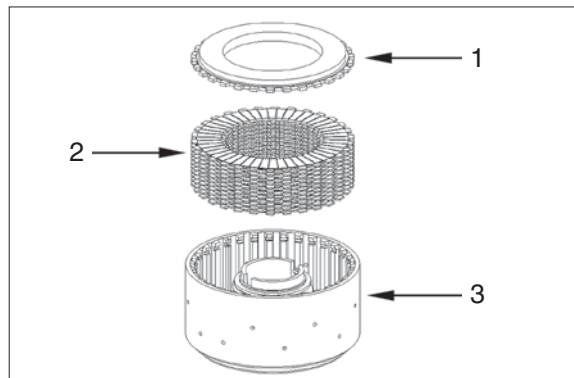

7609ATM086

- ⑫ Preload compression spring (1) unsnap L-ring.

Assembly aid                    5870 345 088

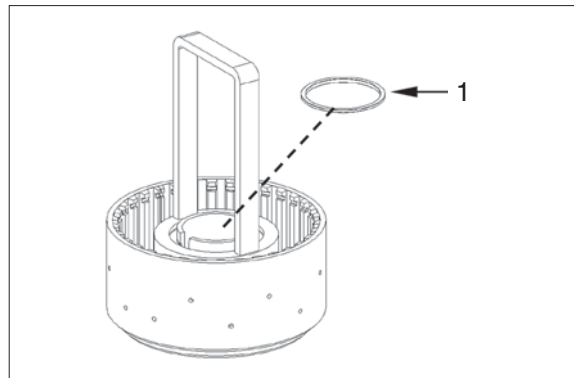

7609ATM087

- ⑬ Remove support shim (1), compression spring (2) and washer (3).

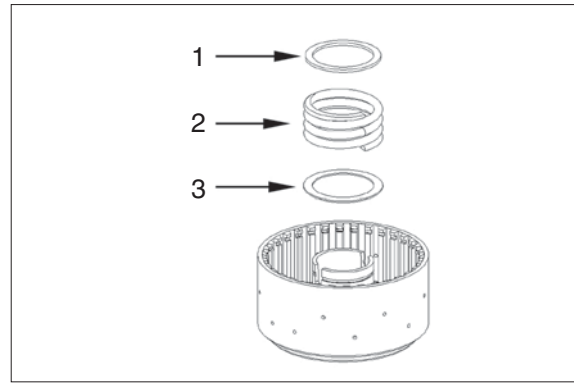

7609ATM088

- ⑭ Lift piston (1) by means of compressed air out of the cylinder bore and remove it.

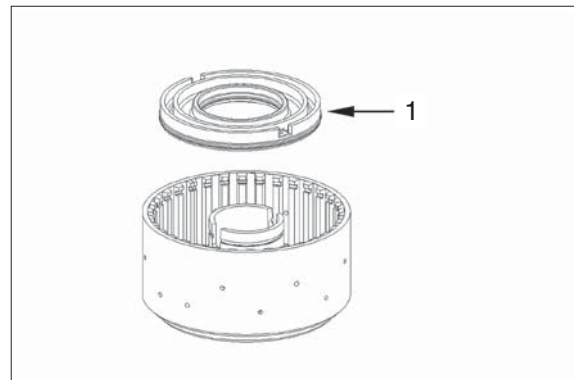

7609ATM089

- ⑮ Remove both O-rings (1 and 2).

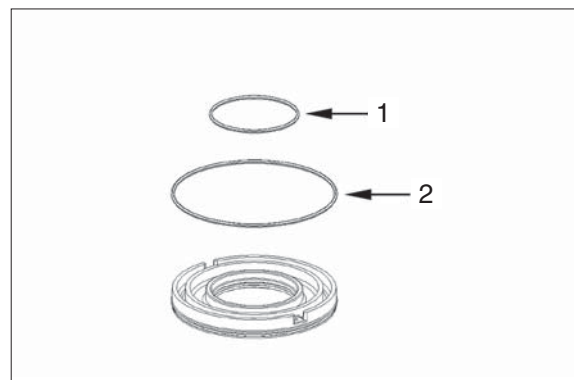

7609ATM090

### (3) K1 clutch

- ① Remove stud bolt (1) and snap out piston ring (2).

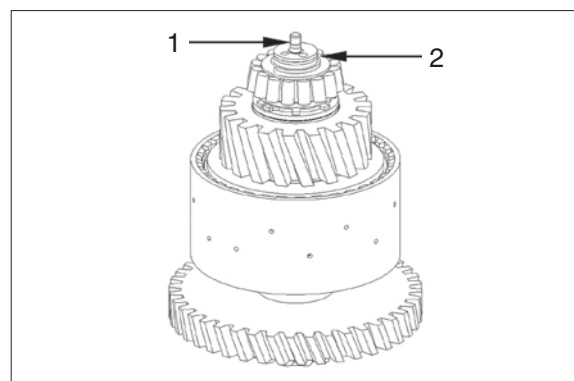

7609ATM091



- ② Pull tapered roller bearing (inner ring) off the shaft.

Forcing device                    5870 026 100  
Grab sleeve                        5873 001 059

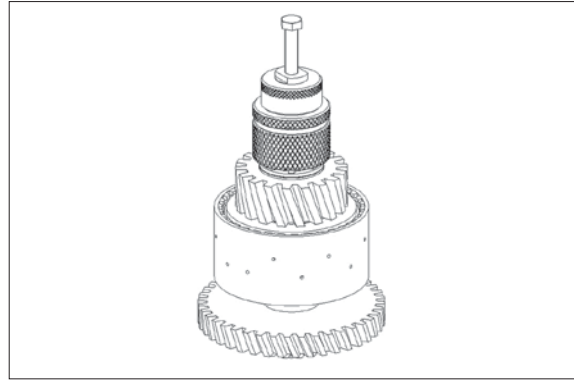

7609ATM092

- ③ Snap out retaining ring (1).

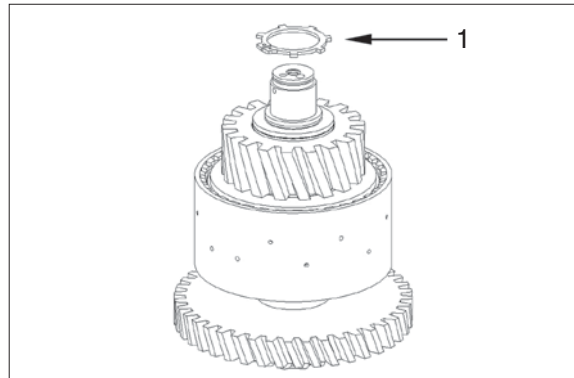

7609ATM093

- ④ Remove axial bearing assy (1).

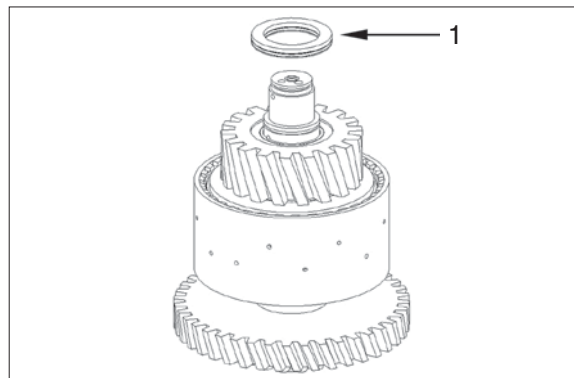

7609ATM094

- ⑤ Take off idler gear (1), remove needle cage (2) and axial bearing assy (3).

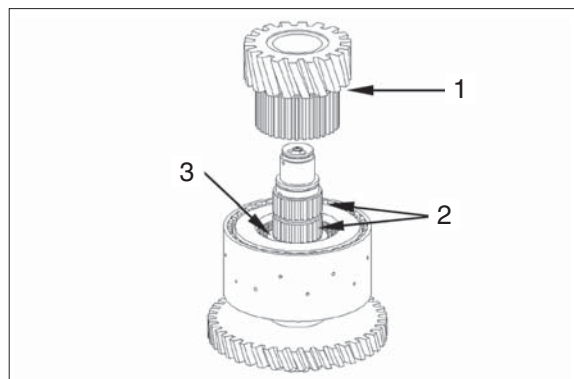

7609ATM095

⑥ Pull clutch (1) off the shaft.

※ Disassembly clutch (1) see figure TM099~TM104.

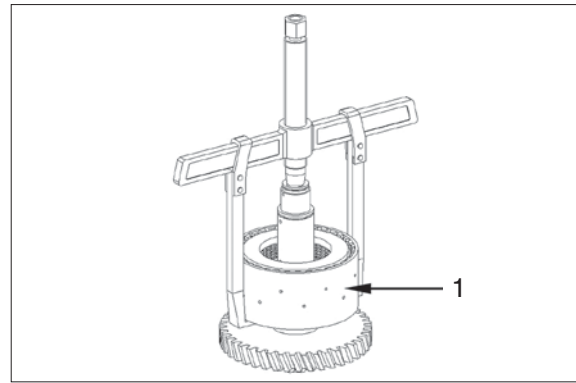

7609ATM096

⑦ Turn shaft (2) by 180° and snap out piston ring (1).

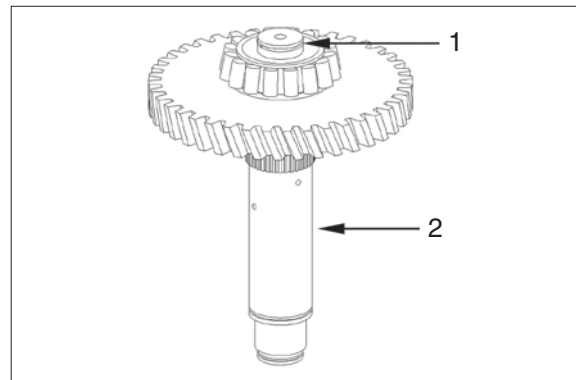

7609ATM097

⑧ Pull tapered roller bearing (inner ring) off the shaft.

Basic tool                    5873 002 001  
Grab sleeve                 5873 002 038

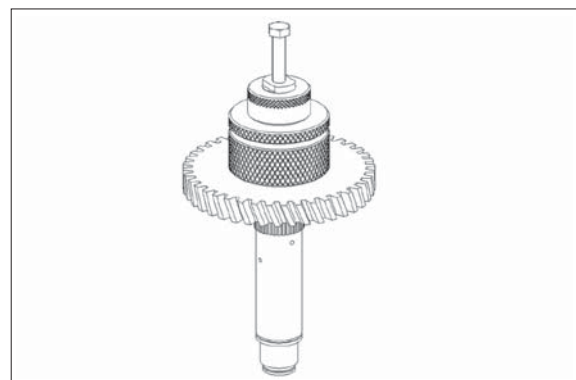

7609ATM098

⑨ Unsnap snap ring (1).

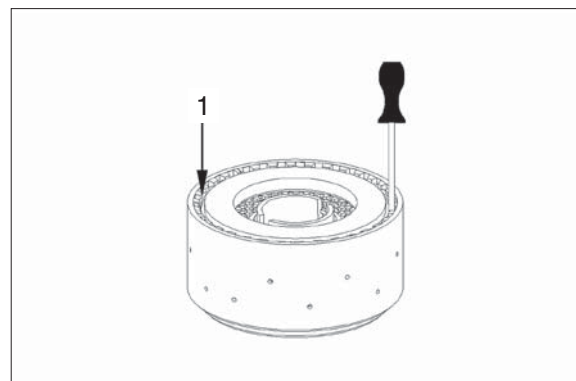

7609ATM099

- ⑩ Remove end shim (1) and disc set (2) out the disc carrier (3).

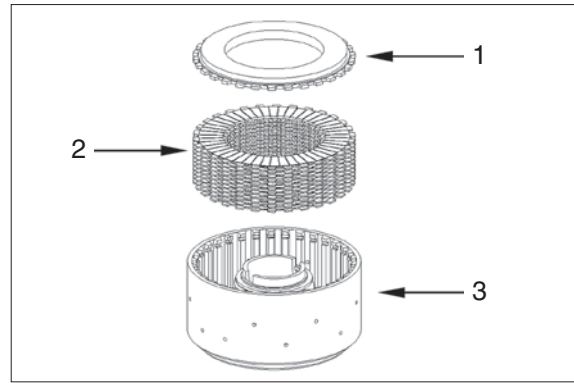

7609ATM100

- ⑪ Preload cup springs unsnap L-ring (1).  
Assembly aid                      5870 345 088

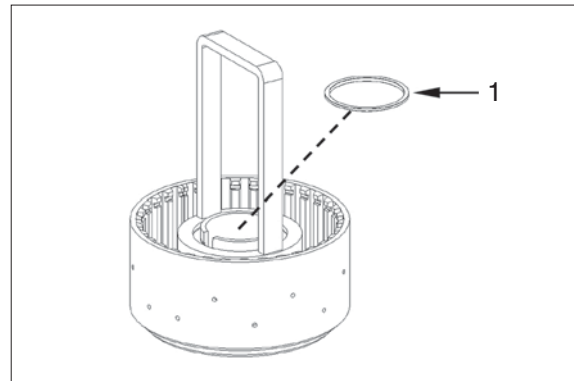

7609ATM101

- ⑫ Remove cup spring package (1).

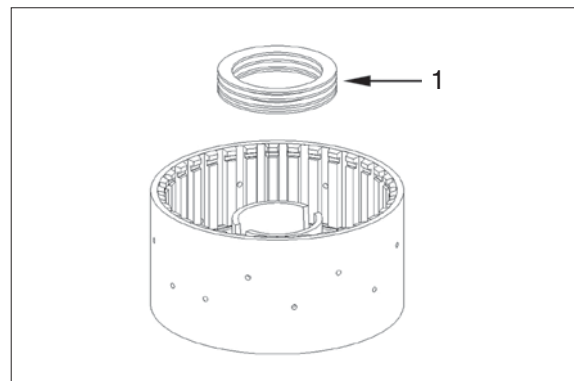

7609ATM102

- ⑬ Lift piston (1) by means of compressed air out of the cylinder bore and remove it.

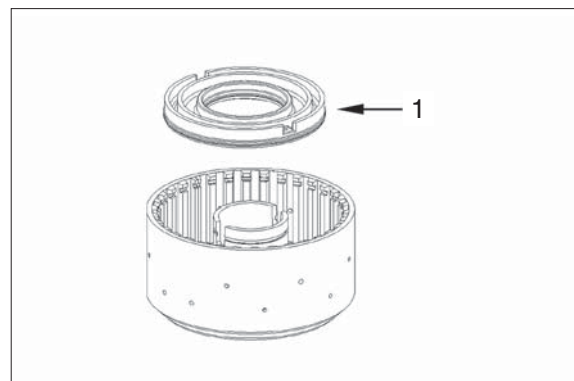

7609ATM103

- ⑭ Remove both O-rings (1 and 2).

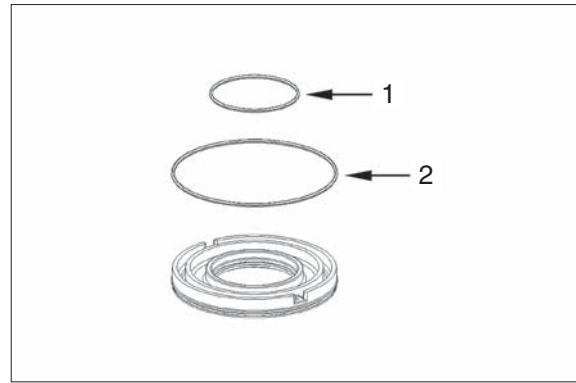

7609ATM104

**(4) K2 clutch**

- ① Remove stud bolt (1) and snap out piston ring (2).

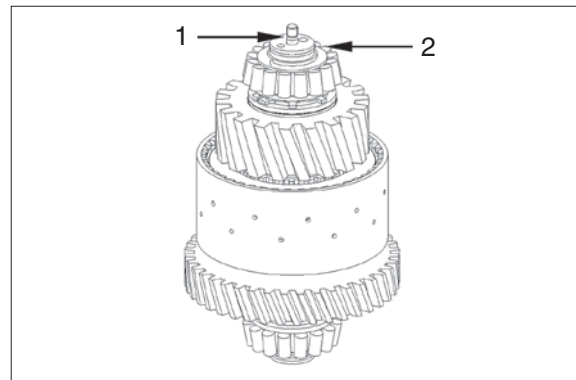

7609ATM105

- ② Pull tapered roller bearing (inner ring) off the shaft.

Forcing device                    5870 026 100  
Grab sleeve                        5873 001 059

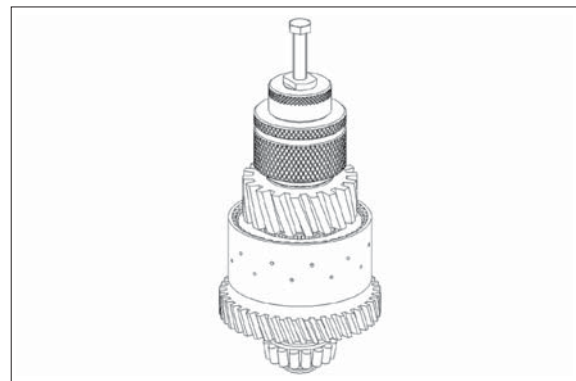

7609ATM106

- ③ Snap out retaining ring (1).

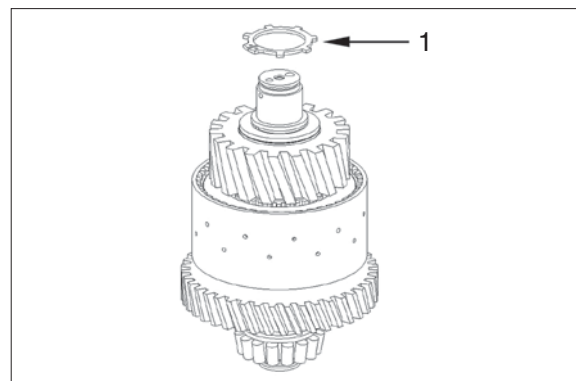

7609ATM107

- ④ Remove axial bearing assy (1).

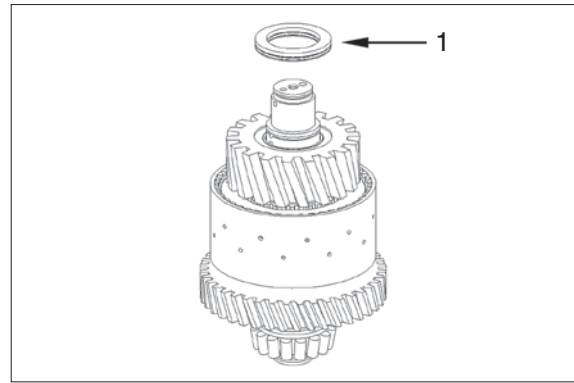

7609ATM108

- ⑤ Take off idler gear (1), remove needle cage (2) and axial bearing assy (3).

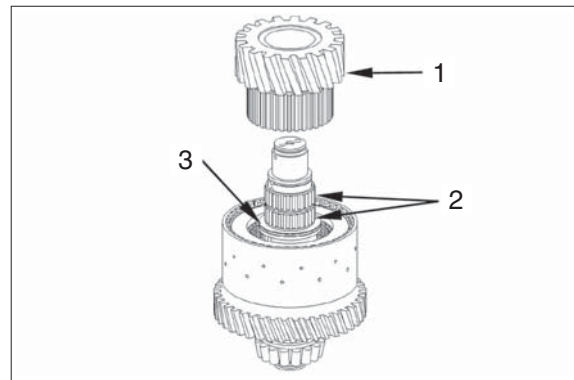

7609ATM109

- ⑥ Pull clutch (1) off the shaft.

※ Disassembly clutch (1) see figure TM113~TM118.

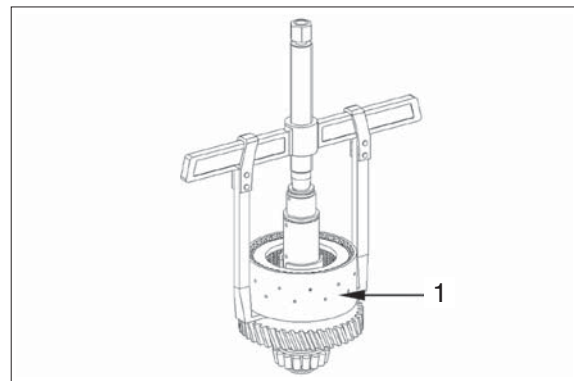

7609ATM110

- ⑦ Turn shaft (2) by 180° and snap out piston ring (1).

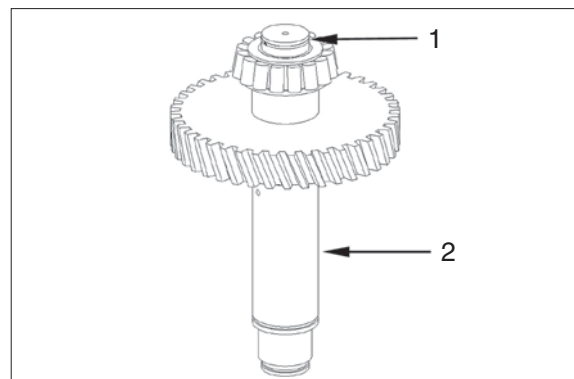

7609ATM111

- ⑧ Pull tapered roller bearing (inner ring) off the shaft.

Forcing device                    5870 026 100  
Grab sleeve                        5873 001 059

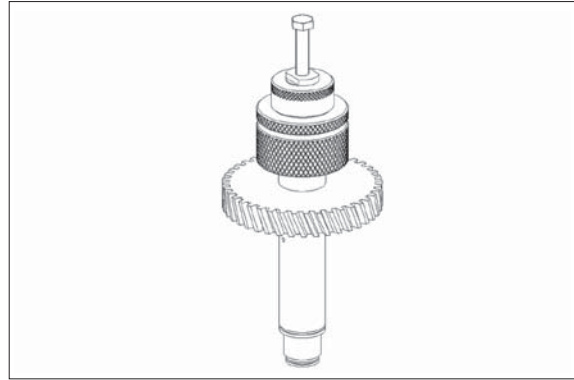

7609ATM112

- ⑨ Unsnap snap ring (1).

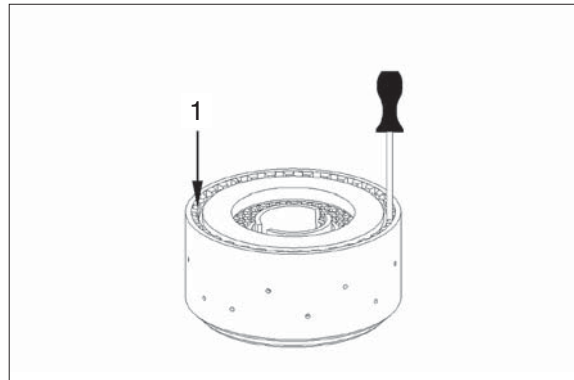

7609ATM113

- ⑩ Remove end shim (1) and disc set (2) out the disc carrier (3).

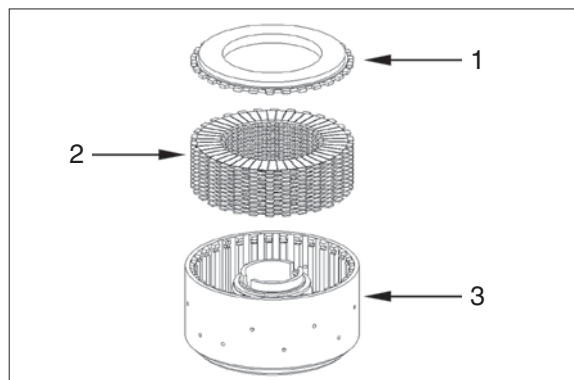

7609ATM114

- ⑪ Preload cup springs unsnap L-ring (1).

Assembly aid                    5870 345 088

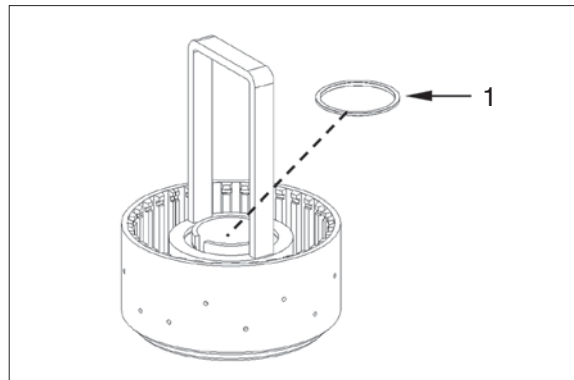

7609ATM115

⑫ Remove cup spring package (1).

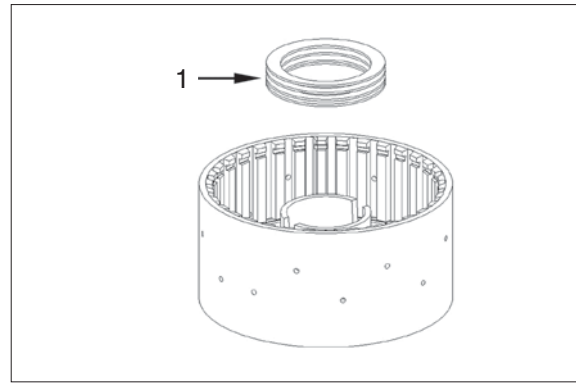

7609ATM116

⑬ Lift piston (1) by means of compressed air out of the cylinder bore and remove it.

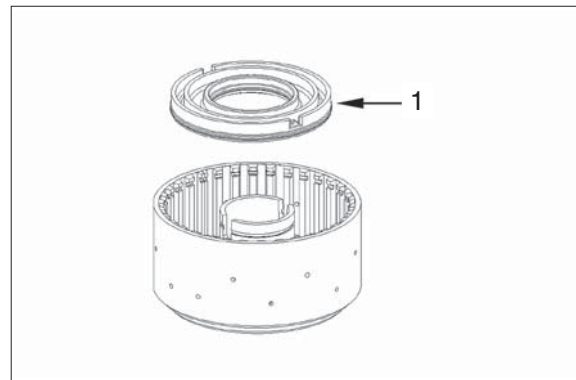

7609ATM117

⑭ Remove both O-rings (1 and 2).

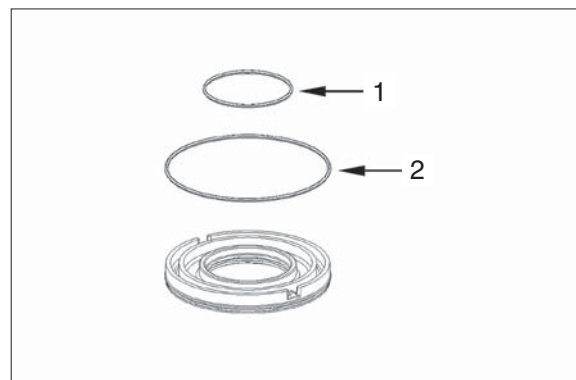

7609ATM118

### (5) K3 clutch

① Snap out piston ring (1).

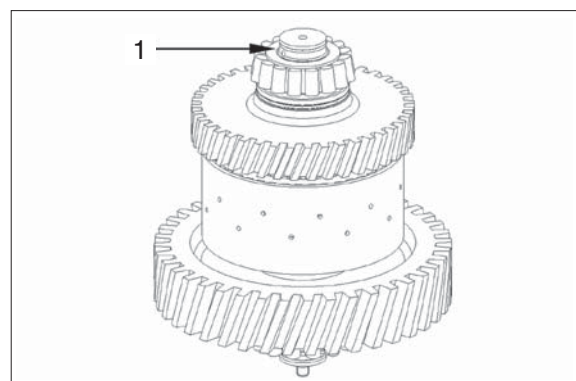

7609ATM119

- ② Pull tapered roller bearing (inner ring) off the shaft.

Forcing device                    5870 026 100  
Grab sleeve                        5873 001 059

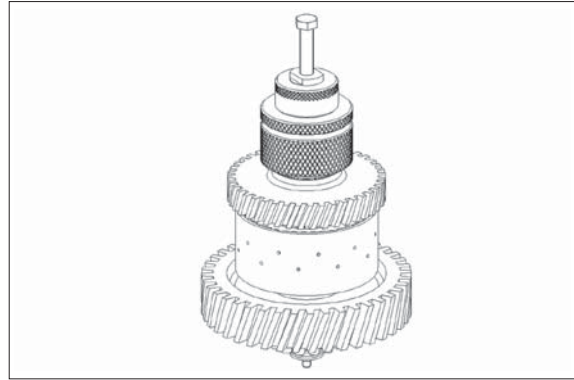

7609ATM120

- ③ Remove axial bearing assy (1).

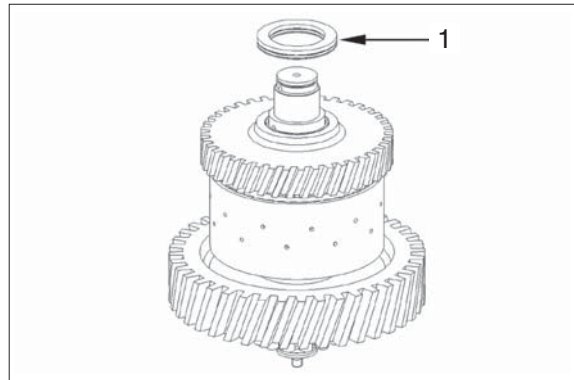

7609ATM121

- ④ Take off idler gear (1), remove needle cage (2) and axial bearing assy (3).

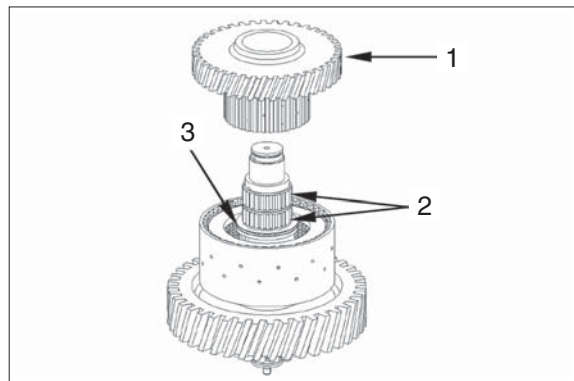

7609ATM122

- ⑤ Pull clutch (1) off the shaft.

※ Disassembly clutch (1) see figure TM126~TM131.

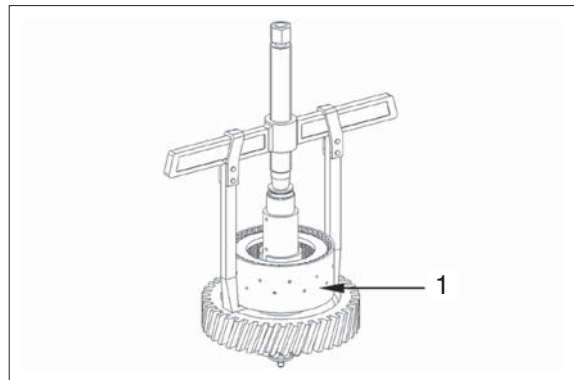

7609ATM123



- ⑥ Remove stud bolt (1) and snap out piston ring (2).

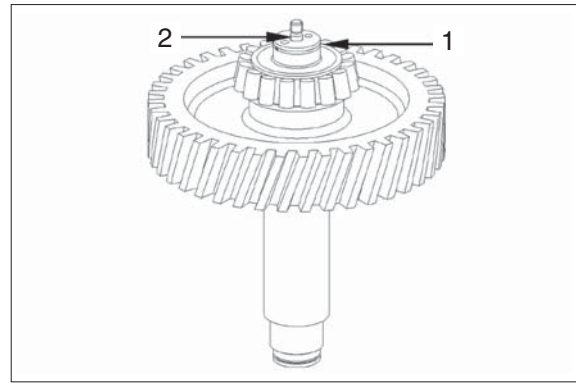

7609ATM124

- ⑦ Pull tapered roller bearing (inner ring) off the shaft.

Basic tool

5873 002 001

Grab sleeve

5873 002 038

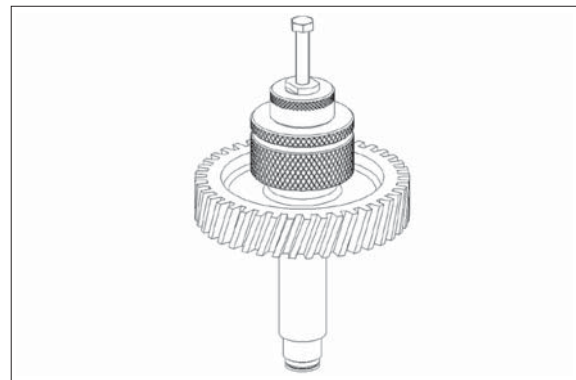

7609ATM125

- ⑧ Unsnap snap ring (1).

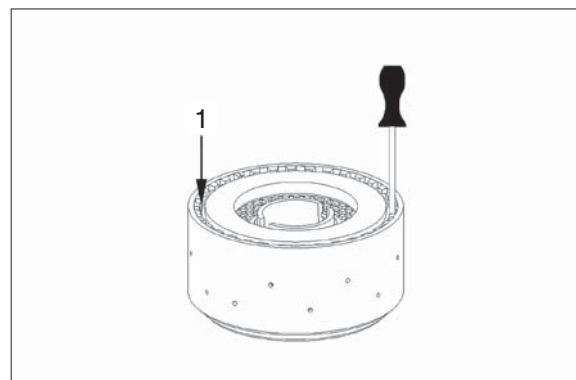

7609ATM126

- ⑨ Remove end shim (1) and disc set (2) out the disc carrier (3).

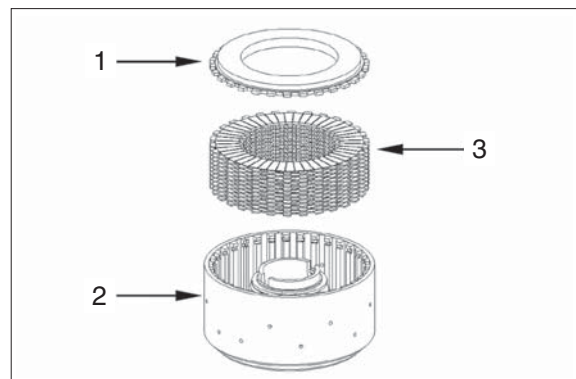

7609ATM127

⑩ Preload cup springs unsnap L-ring (1).

Assembly aid

5870 345 088

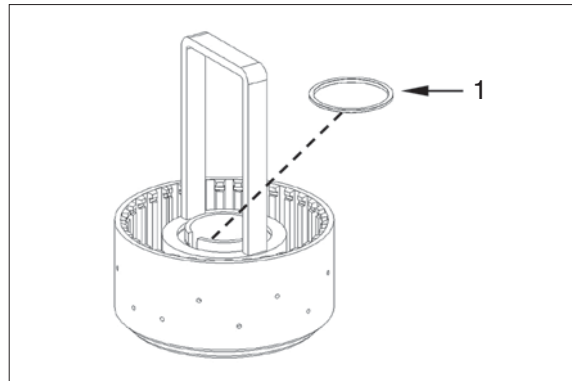

7609ATM128

⑪ Remove cup spring package (1).

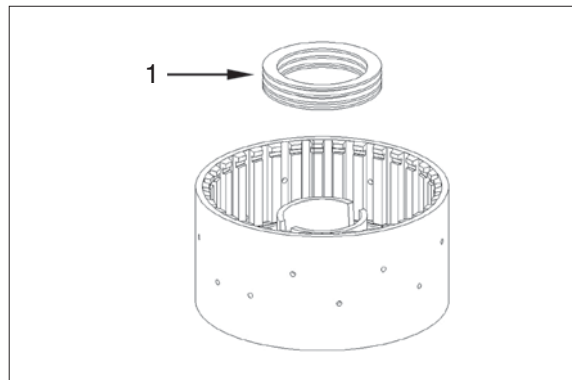

7609ATM129

⑫ Lift piston (1) by means of compressed air out of the cylinder bore and remove it.

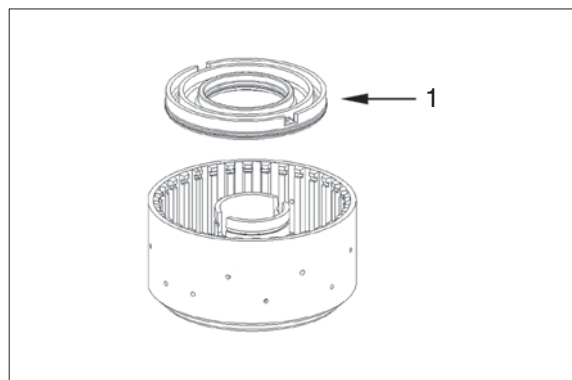

7609ATM130

⑬ Remove both O-rings (1 and 2).

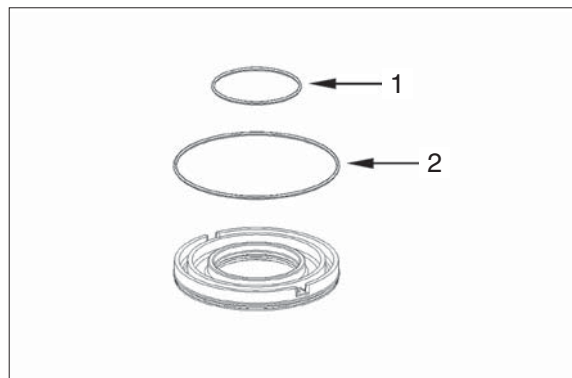

7609ATM131

## (6) K4 clutch

- ① Remove stud bolt (1) and snap out piston ring (2).

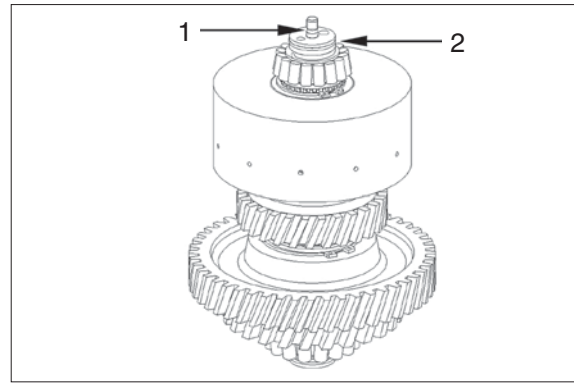

7609ATM132

- ② Pull tapered roller bearing (inner ring) off the shaft.

Forcing device                    5870 026 100

Grab sleeve                        5873 001 057

or

Rapid grip                         5873 011 011

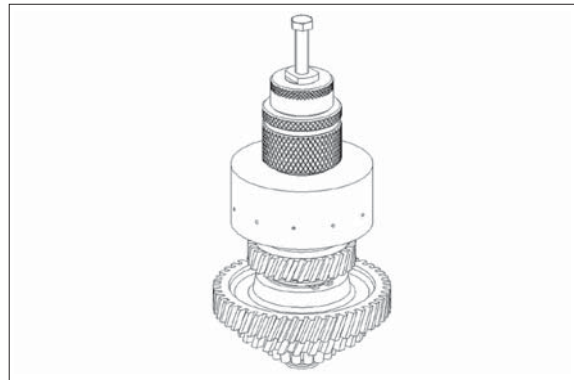

7609ATM133

- ③ Snap out (1) retaining ring.

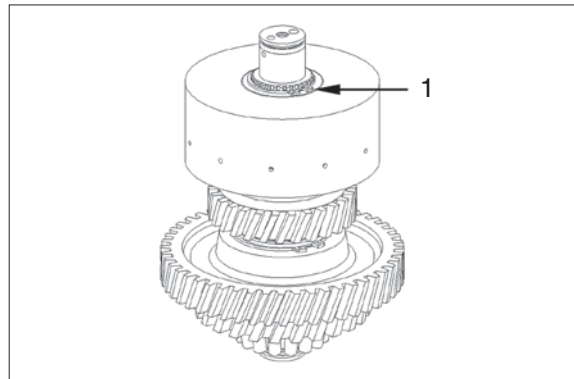

7609ATM134

- ④ Pull clutch (1) off the shaft.

※ Disassembly clutch (1) see figure TM140~TM145.

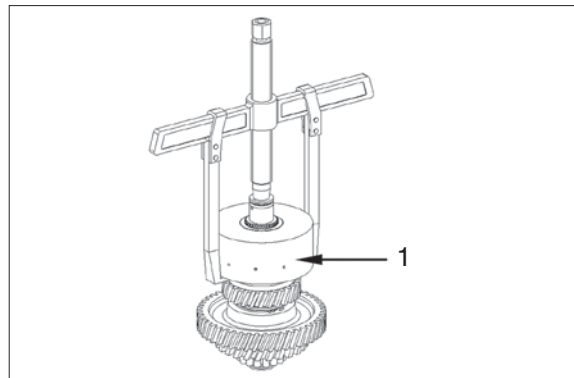

7609ATM135

- ⑤ Remove axial bearing assy (1) and idler gear (2).

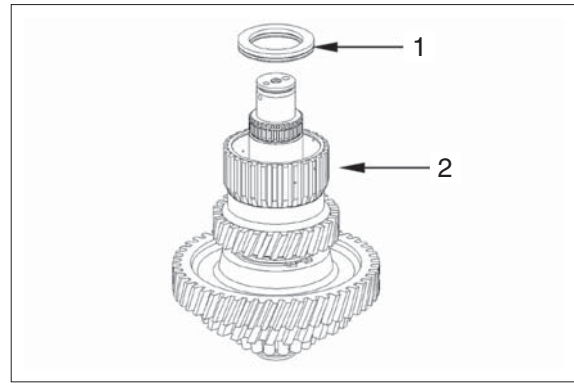

7609ATM136

- ⑥ Remove needle cage (1) and axial bearing assy (2).

※ The gear (3) cannot be removed (shrink fit).

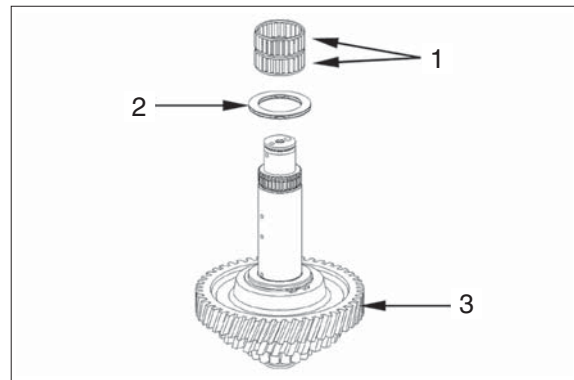

7609ATM137

- ⑦ Turn shaft (2) by 180° and snap out piston ring (1).

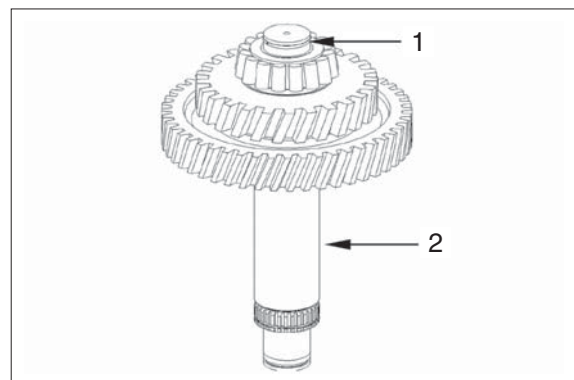

7609ATM138

- ⑧ Pull tapered roller bearing (inner ring) off the shaft.

Forcing device	5870 026 100
Grab sleeve	5873 001 059

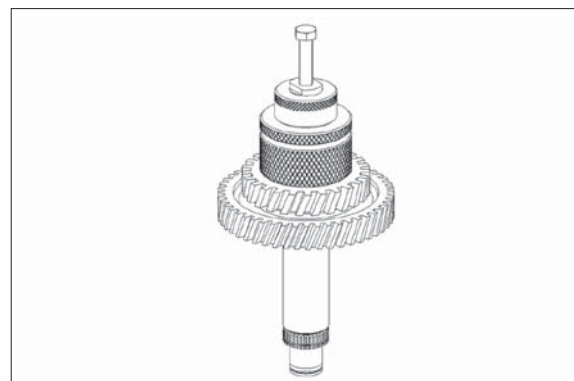

7609ATM139

⑨ Unsnap snap ring (1).

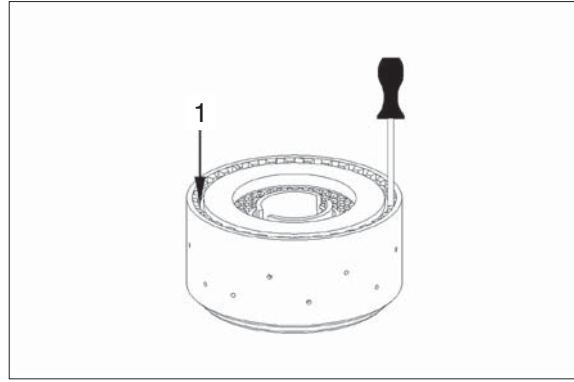

7609ATM140

⑩ Remove end shim (1) and disc set (2) out the disc carrier (3).

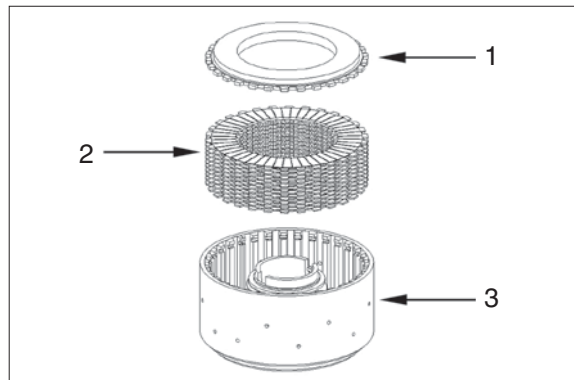

7609ATM141

⑪ Preload cup springs unsnap L-ring (1).

Assembly aid                      5870 345 088

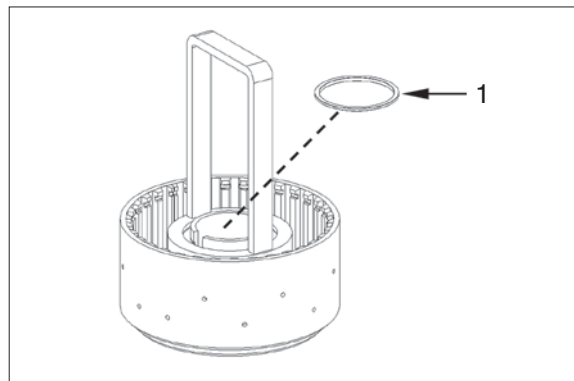

7609ATM142

⑫ Remove cup spring package (1).

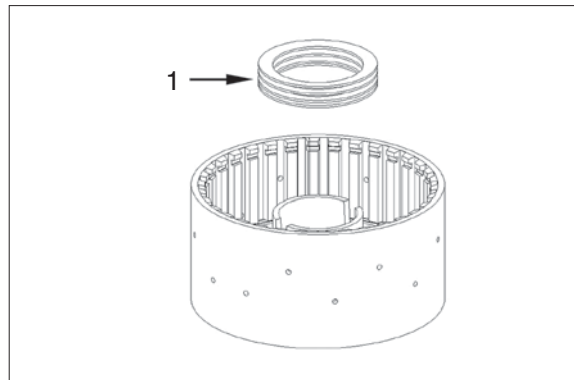

7609ATM143

- ⑬ Lift piston (1) by means of compressed air out of the cylinder bore and remove it.

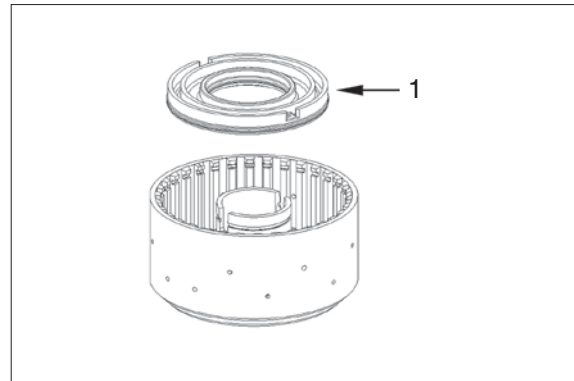

7609ATM144

- ⑭ Remove both O-rings (1 and 2).

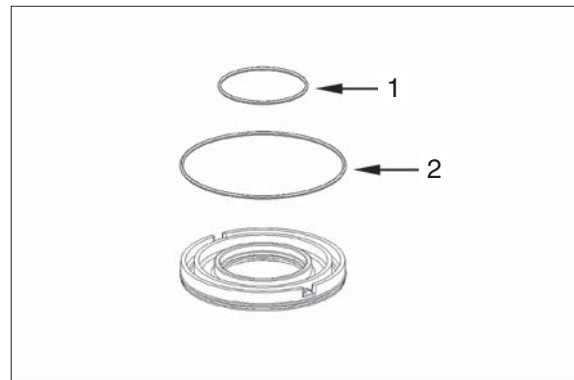

7609ATM145

## (7) Input shaft

- ① Snap out piston ring (1).

Turbine wheel shaft and drive gear (2) are fixed by a snap ring.

- ※ When separated, the components will be destroyed.

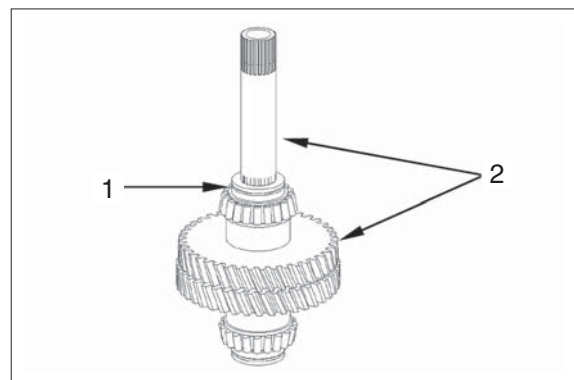

7609ATM146

- ② Pull tapered roller bearing (inner ring) off the drive gear.

Basic tool	5873 001 000
Grab sleeve	5873 001 058
or	
Rapid grip	5873 011 014

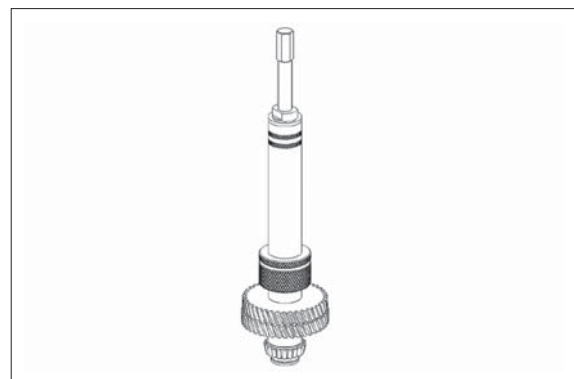

7609ATM147

- ③ Pull tapered roller bearing (inner ring) off the drive gear.

Grab sleeve 5873 001 058

Forcing device 5870 026 100

or

Rapid grip 5873 011 014

It is not possible to separate input shaft and gear (1) -shrink fit-.

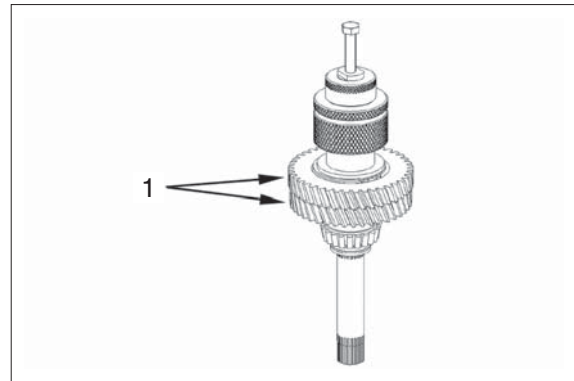

7609ATM148

## (8) Output shaft

- ① Pull tapered roller bearing (inner ring) off the output shaft and remove oil screen sheet (1).

Basic tool 5873 002 001

Grab sleeve 5873 002 038

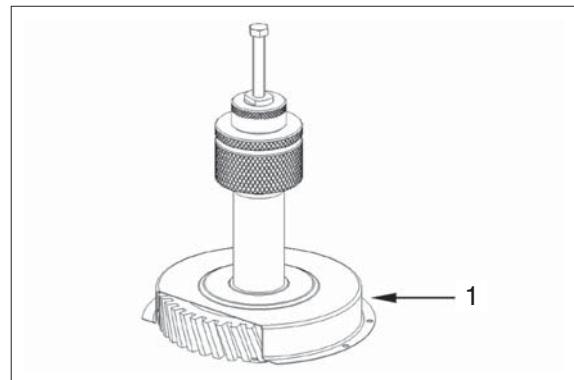

7609ATM149

- ② Turn output shaft by 180° and pull off tapered roller bearing (inner ring).

Basic tool 5873 002 001

Grab sleeve 5873 002 038

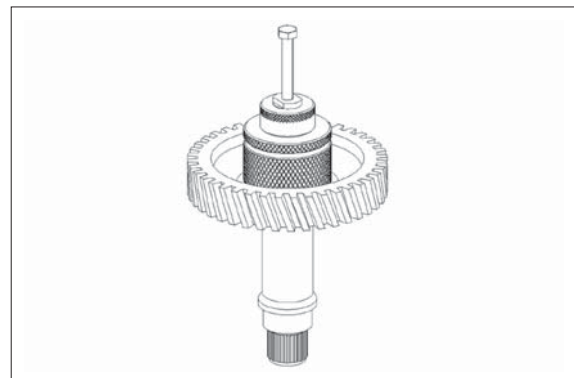

7609ATM150

## 8) REASSEMBLY

Clutches KV / KR / K1 / K2 / K3 / K4  
input and output shaft

### (1) KV Clutch

- ① Heat up bearing inner ring (approx. 120°C)

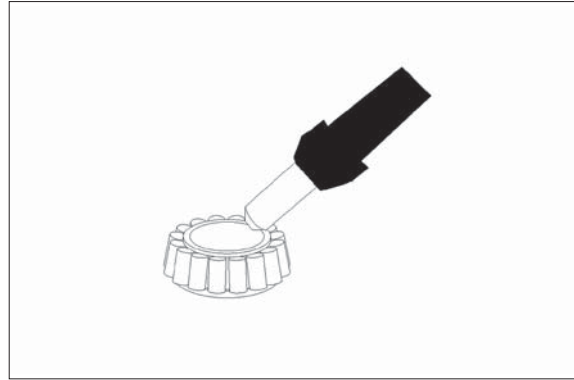

7609ATM151

- ② Mount bearing inner ring (1) until contact is obtained.

Fit rectangular ring 40×2.5 (2).

- ※ Wear protective gloves.
- ※ Adjust bearing inner ring after cooling-down.

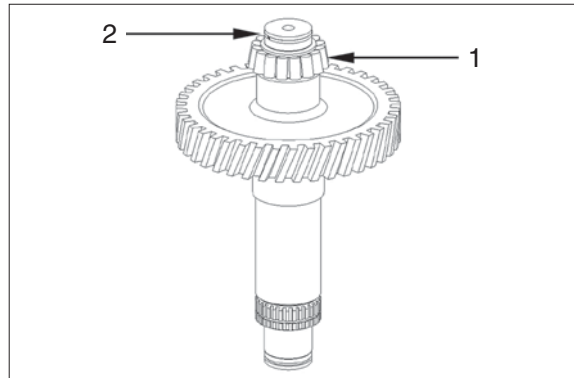

7609ATM152

- ③ Mount needle cage 60×68×20 (1) onto the shaft and oil it.

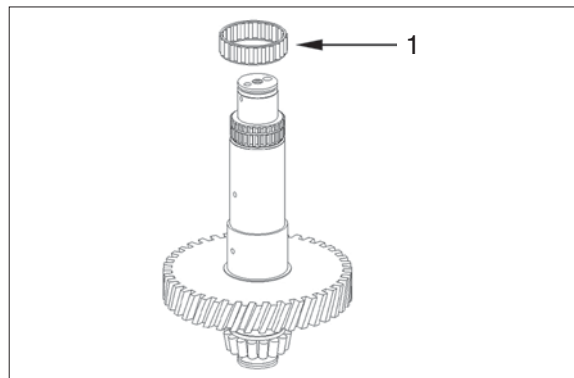

7609ATM153

- ④ Install ball bearing 50×90×18 (2) into the idler gear (1) until contact is obtained and fix it by means of retaining ring 90×3 (3).

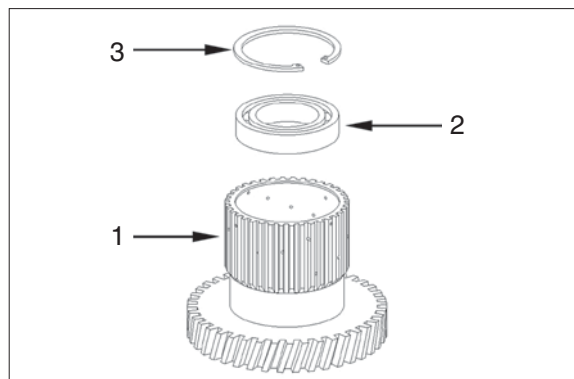

7609ATM154



- ⑤ Press in preassembled idler gear (1) onto the shaft until contact is obtained.

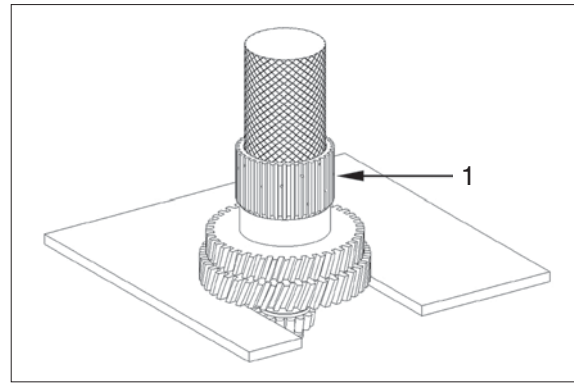

7609ATM155

- ⑥ Place both O-rings (1 and 2) into the piston grooves and oil them.

- 1 75×3  
2 142×3

- ※ Check function of the drain valve (see arrow) - There must be no jamming of the ball.

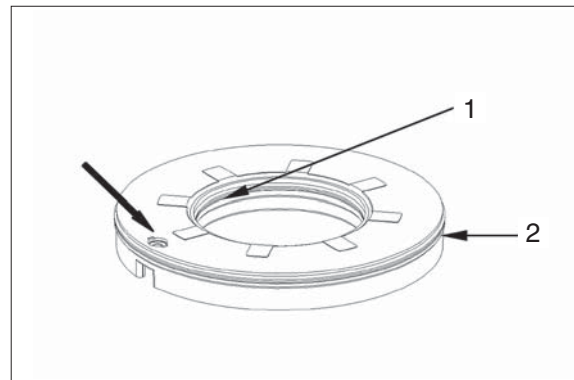

7609ATM156

- ⑦ Place piston (1) into the disk carrier.

- ※ Observe installation position, see figure.

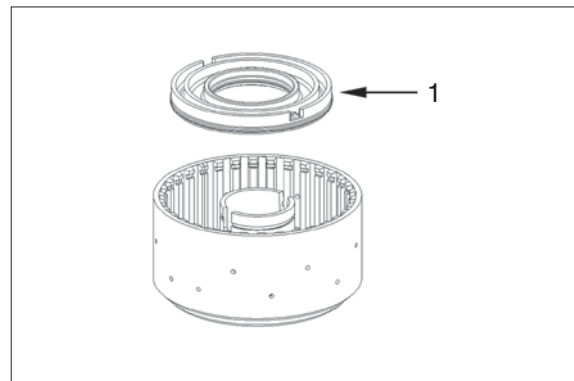

7609ATM157

- ⑧ Use a hand-operated press to place piston into the disk carrier by means of the assembly aid.

Assembly aid 5870 345 088

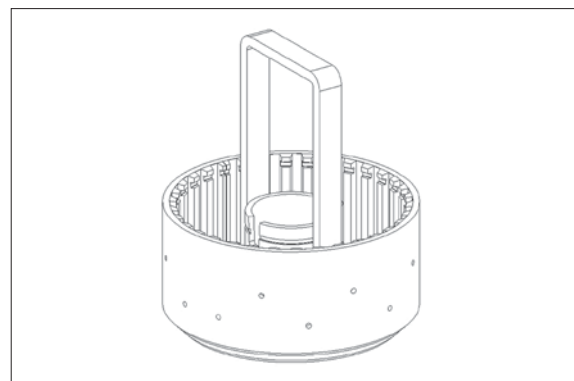

7609ATM158

- ⑨ Mount inner installer (S) onto the disk carrier.

Install disk (1), compression spring (2), support shim (3) and L-ring (4).

- ※ Installation position support shim and L-ring see TM161.

Inner installer : see figure TM160

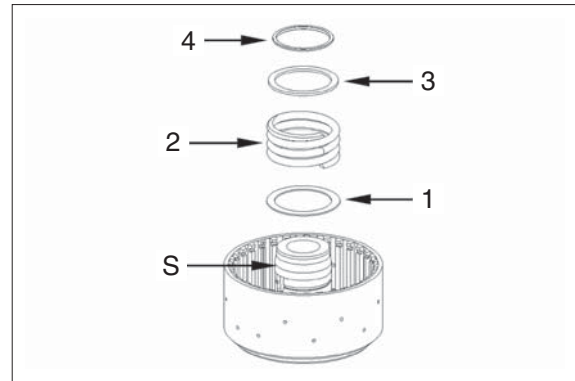

7609ATM159

- ⑩ Preload compression spring by means of assembly aid (S1) and pressure piece (S2), until L-ring has engaged into the annular groove.

Assembly aid (S1) 5870 345 088

Assembly fixture (S + S2) 5870 345 124  
(Inner installer and pressure piece)

- ※ It is always necessary to mount a new L-ring.

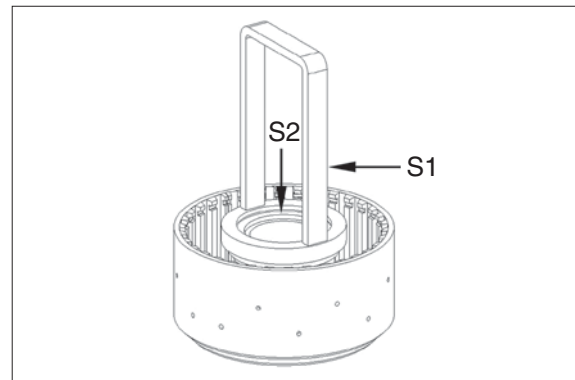

7609ATM160

Disk carrier with piston retraction :

- 1 Washer
- 2 Compression spring
- 3 Support shim
- 4 L-ring
- 5 Disk carrier
- 6 Drain valve (piston)
- 7 Piston with O-rings

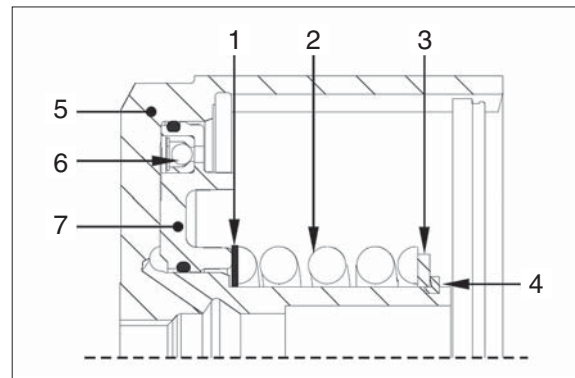

7609ATM161

- ※ Different clutches (disc arrangements with relevant disc clearance) can be installed, depending on the parts manual.

- ※ The actually installed clutch and disc arrangement must be taken from the corresponding parts manual.

- ※ Figure no. : TM162 and TM163 illustrates the different disc arrangements.

- ⑪ Install outer and inner disks alternately into the disk carrier (4) as personated in figure TM162.

- 1 Friction disk-coated on one side (1 pcs)
- 2 Outer disks (10 pcs)
- 3 Inner disks (10 pcs)

- ※ Take care that the uncoated (blank) side of the friction disk (1) is showing towards the piston.

Number of friction surfaces : 20

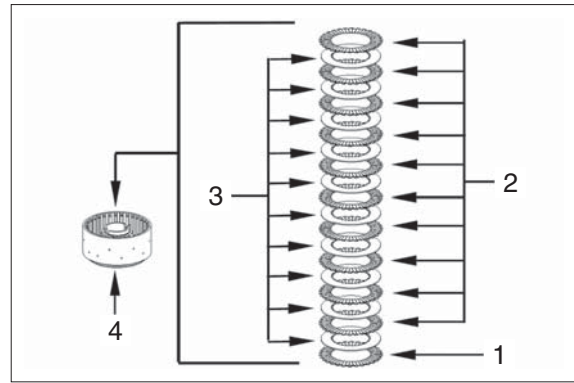

7609ATM162

- ⑫ Install outer and inner disks alternately into the disk carrier (4) as personated in TM163.

- 1 Friction disk-coated on one side (1 pcs)
- 2 Outer disks (10 pcs)
- 3 Inner disks (10 pcs)

- ※ Take care that the uncoated (blank) side of the friction disk (1) is showing towards the piston.

Number of friction surfaces : 16

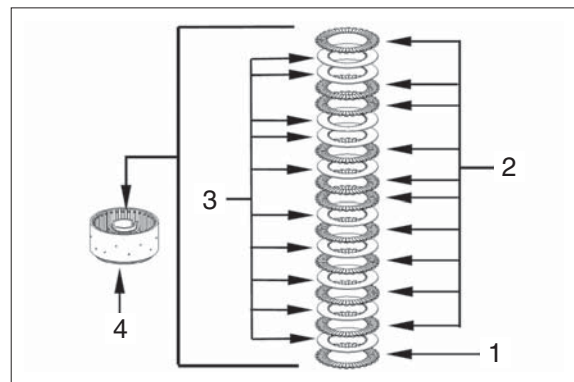

7609ATM163

- ⑬ Mount end plate (1) and fix disk package by means of snap ring (2) (e.g. thickness = 2.65 mm / recommended value).

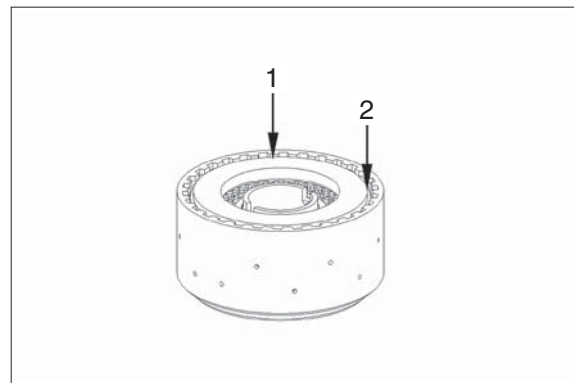

7609ATM164

- ⑭ Press on end plate with F (approx. 100 N = 10 kg) and set dial indicator to "zero".

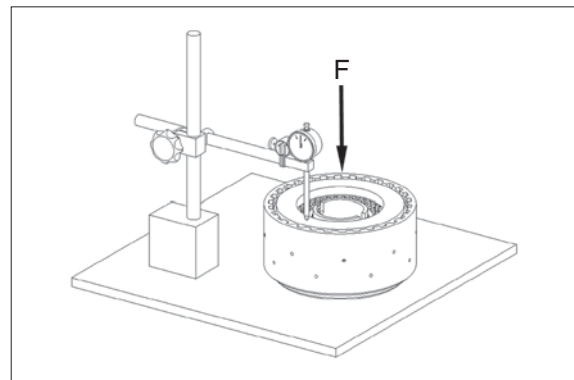

7609ATM165

⑮ Then press end plate against the snap ring (upwards) and read disk clearance.

※ Disk clearance : 2.65~2.95 mm

※ In case of deviations, the disk clearance must be corrected with an appropriate snap ring (optional thicknesses = 2.1~4.2 mm).

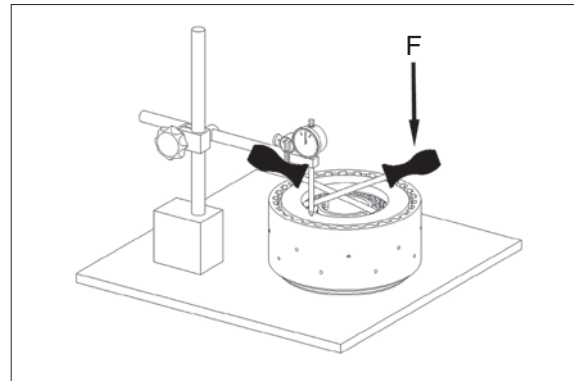

7609ATM166

⑯ Heat up clutch inner diameter (approx. 120°C).

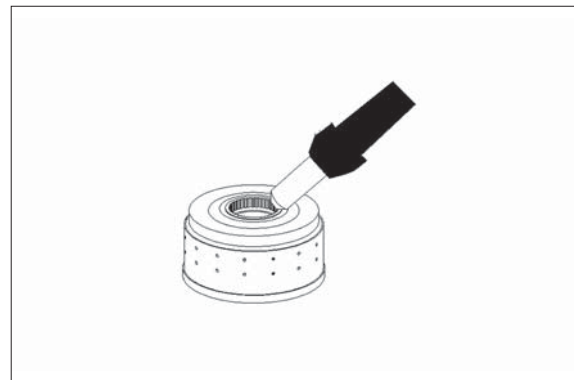

7609ATM167

⑰ Install clutch until contact is obtained.

Mount inner disks onto the inner disk carrier by means of short left/right rotations.

※ Wear protective gloves.

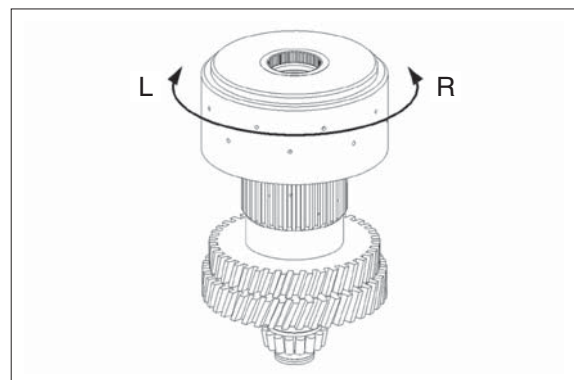

7609ATM168

⑱ Fix clutch (1) by means of retaining ring 55×2 (2).

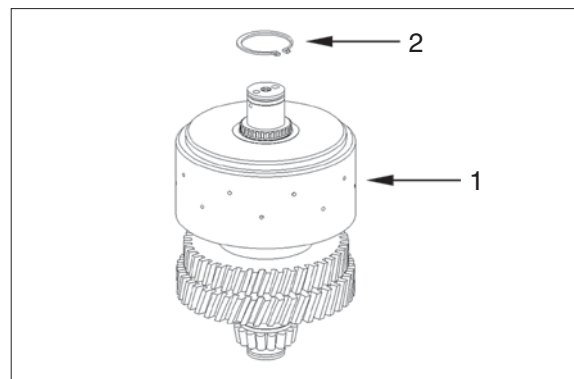

7609ATM169

- ⑱ Heat up bearing inner ring (approx. 120°C).

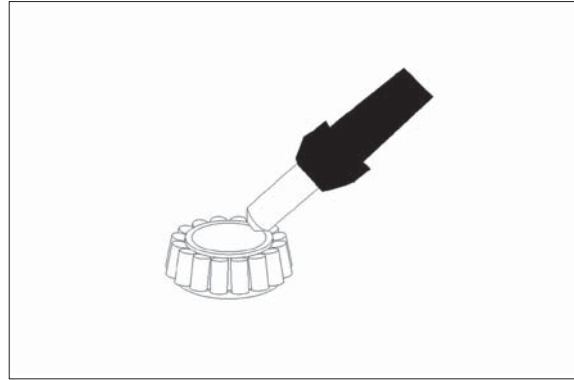

7609ATM170

- ⑳ Mount bearing inner ring (1) until contact is obtained.

- ※ Wear protective gloves.
- ※ Adjust bearing inner ring after cooling-down.

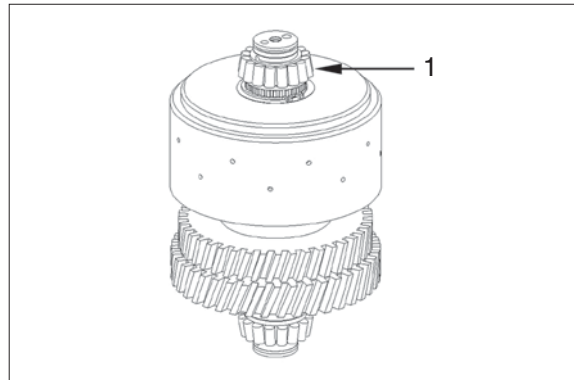

7609ATM171

- ㉑ Mount stud bolt (1).

- Tightening torque (M10/8.8×16) :  
1.73 kgf · m (12.5 lbf · ft)

Fit rectangular ring 40×2.5 (2).

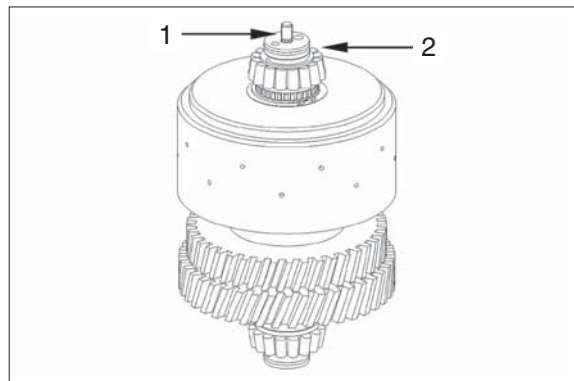

7609ATM172

- ※ Check closing and opening of the clutch by means of compressed air at the hole (see arrow).  
Closing and opening of the clutch must be clearly audible.

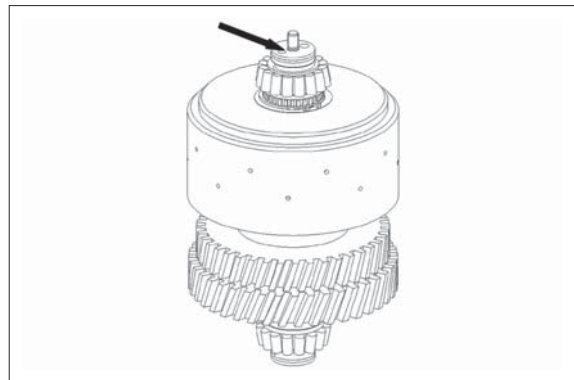

7609ATM173

② Install sealing cap orifice (1).

※ Wet contact surface with loctite (Type No. 262).

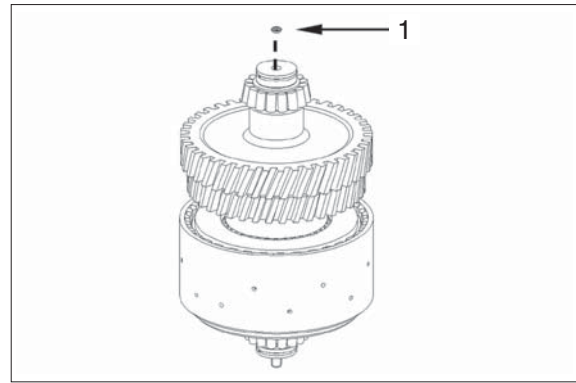

7609ATM174

## (2) KR Clutch

① Heat up bearing inner ring (approx. 120°C)

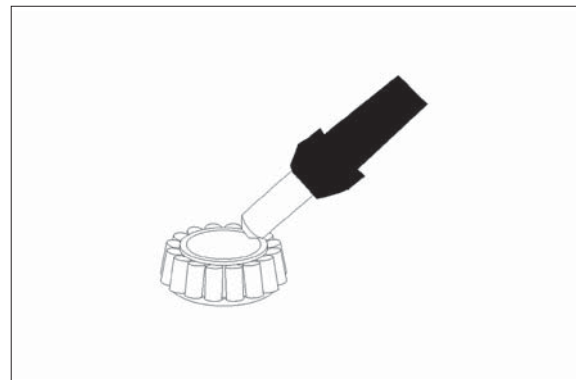

7609ATM175

② Mount bearing inner ring (1) until contact is obtained.

Fit rectangular ring 40 × 2.5 (2).

※ Wear protective gloves.

※ Adjust bearing inner ring after cooling-down.

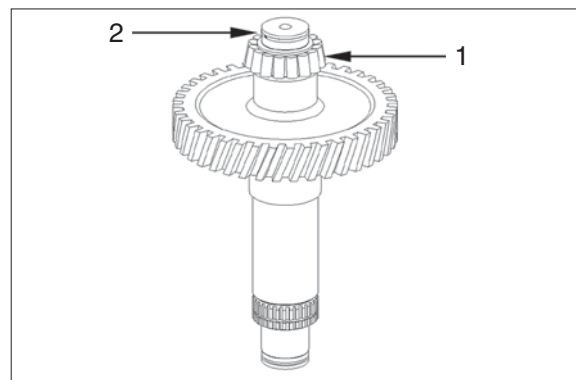

7609ATM176

③ Mount needle cage 60 × 68 × 20 (1) onto the shaft and oil it.

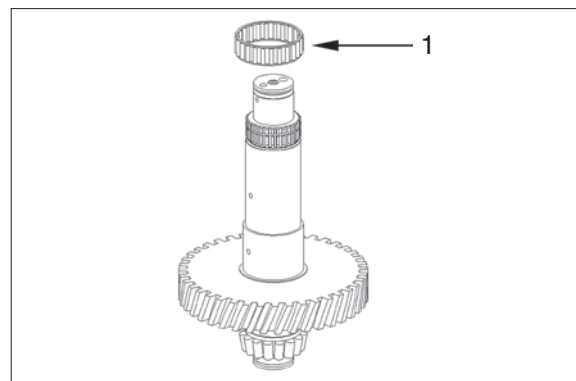

7609ATM177

- ④ Install ball bearing 50×90×18 (2) into the idler gear (1) until contact is obtained and fix it by means of retaining ring 90×3 (3).

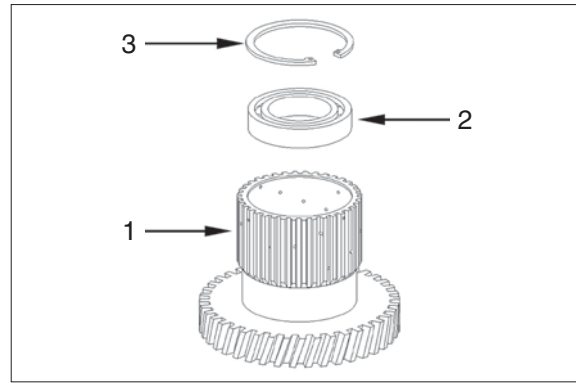

7609ATM178

- ⑤ Press in preassembled idler gear (1) onto the shaft until contact is obtained.

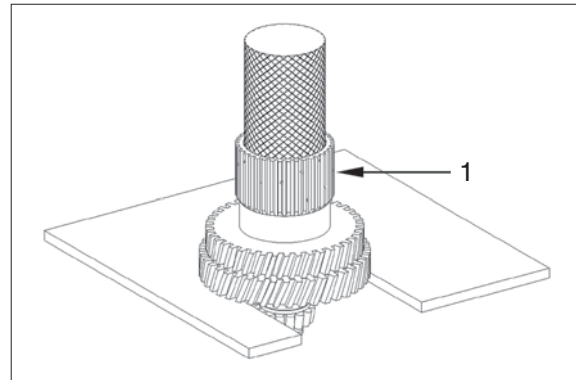

7609ATM179

- ⑥ Place both O-rings (1 and 2) into the piston grooves and oil them.

- 1 75×3  
2 142×3

- ※ Check function of the drain valve (see arrow) - There must be no jamming of the ball.

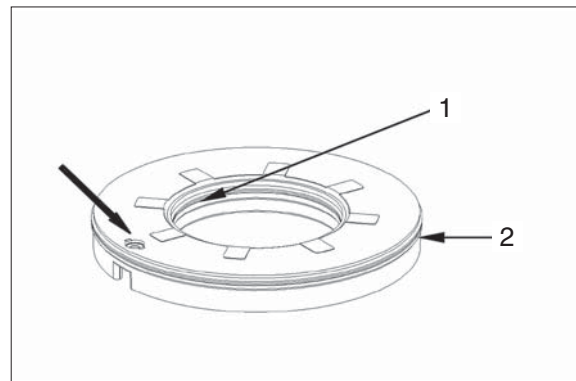

7609ATM180

- ⑦ Place piston (1) into the disk carrier.

- ※ Observe installation position, see figure.

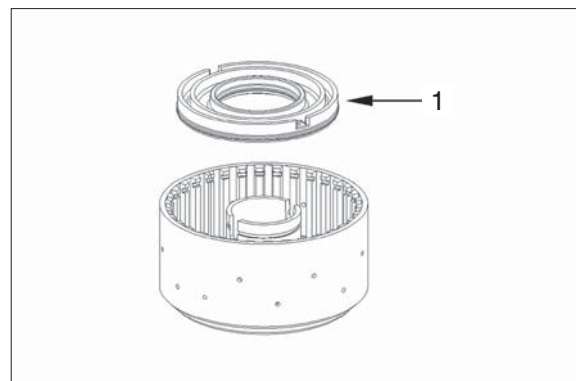

7609ATM181

- ⑧ Use a hand-operated press to place piston into the disk carrier by means of the assembly aid.

Assembly aid 5870 345 088

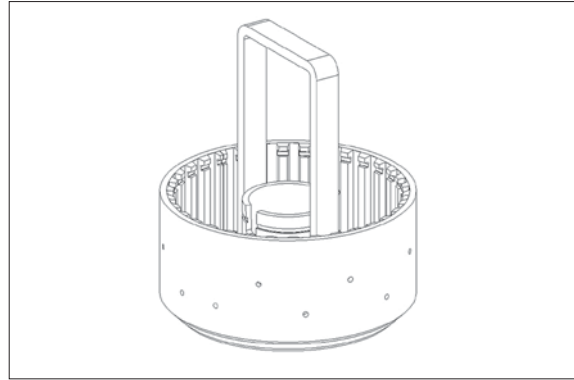

7609ATM182

- ⑨ Mount inner installer (S) onto the disk carrier.

Install disk (1), compression spring (2), support shim (3) and L-ring (4).

- ※ Installation position support shim and L-ring see figure TM185.

Inner installer : see figure TM184

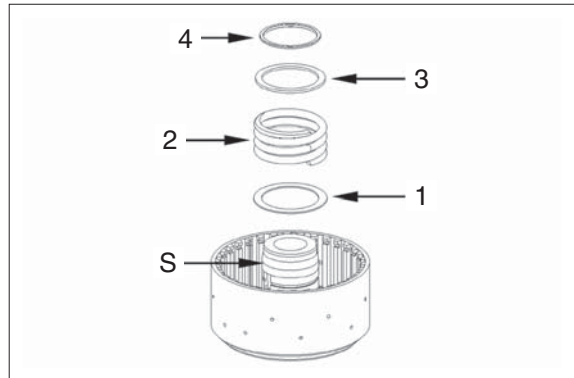

7609ATM183

- ⑩ Preload compression spring by means of assembly aid (S1) and pressure piece (S2), until L-ring has engaged into the annular groove.

Assembly aid (S1) 5870 345 088

Assembly fixture (S + S2) 5870 345 124  
(Inner installer and pressure piece)

- ※ It is always necessary to mount a new L-ring.

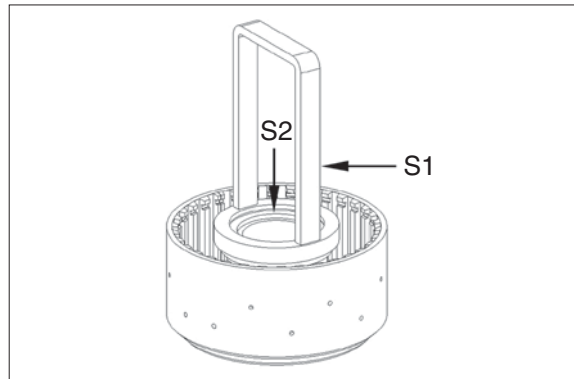

7609ATM184

Disk carrier with piston retraction :

- 1 Washer
- 2 Compression spring
- 3 Support shim
- 4 L-ring
- 5 Disk carrier
- 6 Drain valve (piston)
- 7 Piston with O-rings

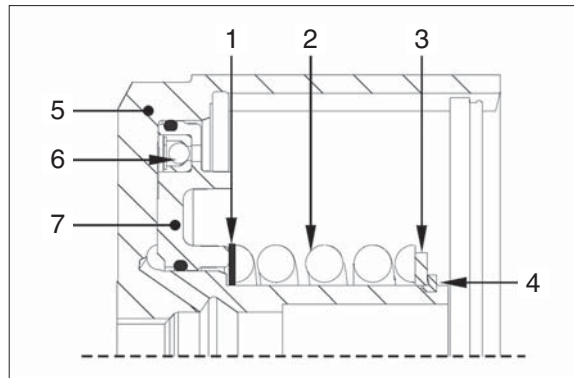

7609ATM185



- ※ Different clutches (disc arrangements with relevant disc clearance) can be installed, depending on the parts manual.
- ※ The actually installed clutch and disc arrangement must be taken from the corresponding parts manual.
- ※ Figure no. : TM186 and TM187 illustrates the different disc arrangements.

⑪ Install outer and inner disks alternately into the disk carrier (4) as personated in figure TM186.

- 1 Friction disk-coated on one side (1 pcs)
- 2 Outer disks (10 pcs)
- 3 Inner disks (10 pcs)

※ Take care that the uncoated (blank) side of the friction disk (1) is showing towards the piston.

Number of friction surfaces : 20

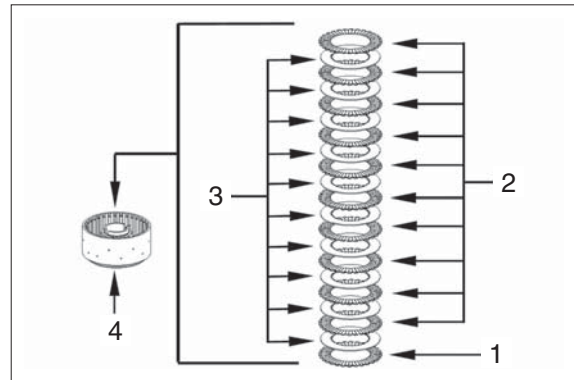

7609ATM186

⑫ Install outer and inner disks alternately into the disk carrier (4) as personated in figure TM187.

- 1 Friction disk-coated on one side (1 pcs)
- 2 Outer disks (10 pcs)
- 3 Inner disks (10 pcs)

※ Take care that the uncoated (blank) side of the friction disk (1) is showing towards the piston.

Number of friction surfaces : 16

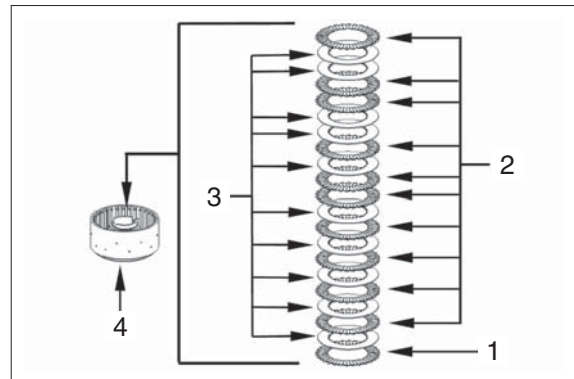

7609ATM187

- ⑬ Mount end plate (1) and fix disk package by means of snap ring (2) (e.g. thickness = 2.65 mm / recommended value).

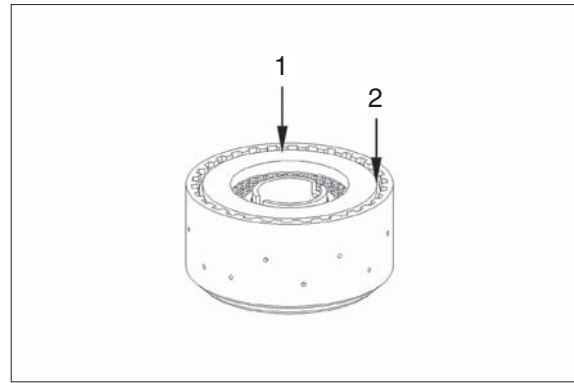

7609ATM188

- ⑭ Press on end plate with F (approx. 100 N = 10 kg) and set dial indicator to "zero".

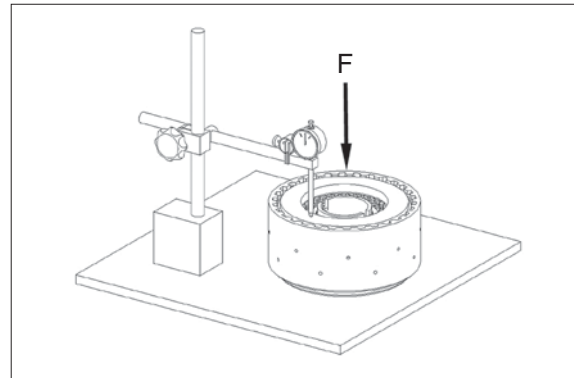

7609ATM189

- ⑮ Then press end plate against the snap ring (upwards) and read disk clearance.

- ※ Disk clearance : 2.65~2.95 mm
- ※ In case of deviations, the disk clearance must be corrected with an appropriate snap ring (optional thicknesses = 2.1~4.2 mm).

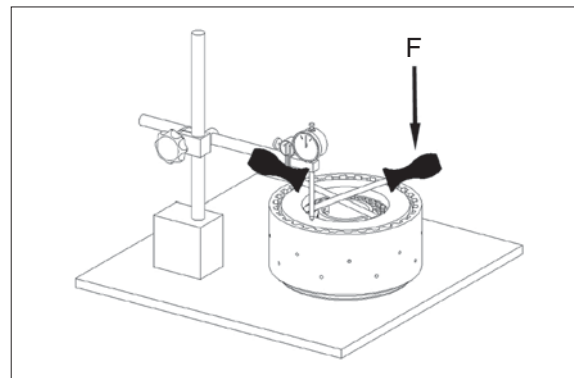

7609ATM190

- ⑯ Heat up clutch inner diameter (approx. 120°C).



7609ATM191

⑰ Install clutch until contact is obtained.

Mount inner disks onto the inner disk carrier by means of short left/right rotations.

※ Wear protective gloves.

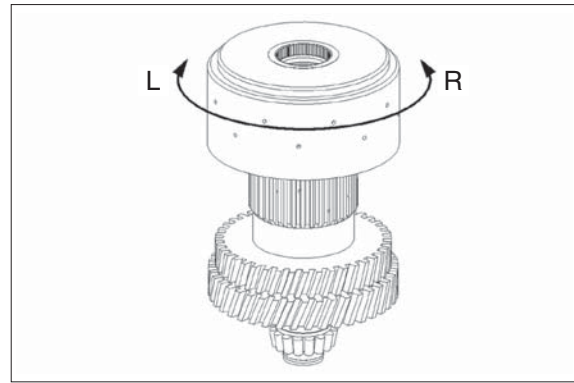

7609ATM192

⑱ Fix clutch (1) by means of retaining ring 55×2 (2).

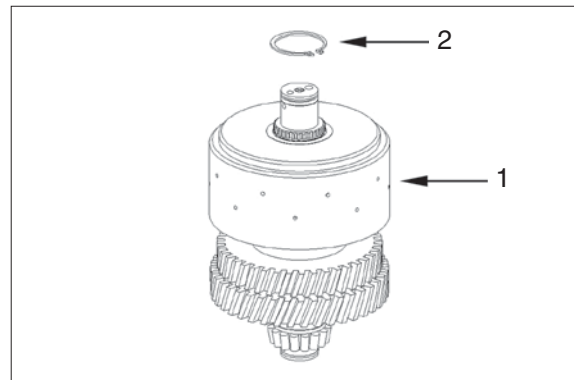

7609ATM193

⑲ Heat up bearing inner ring (approx. 120°C).



7609ATM194

⑳ Mount bearing inner ring (1) until contact is obtained.

※ Wear protective gloves.

※ Adjust bearing inner ring after cooling-down.

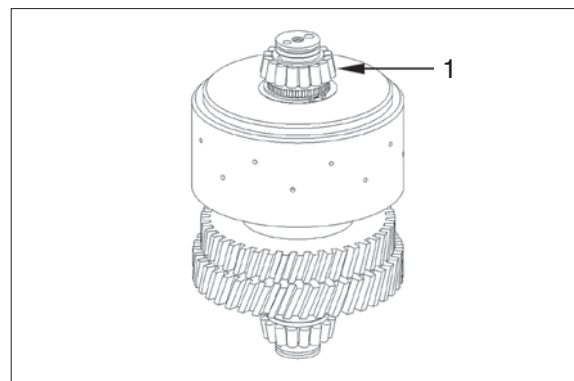

7609ATM195

② Mount stud bolt (1).

- Tightening torque (M10/8.8×16) :  
1.73 kgf · m (12.5 lbf · ft)

Fit rectangular ring 40×2.5 (2).

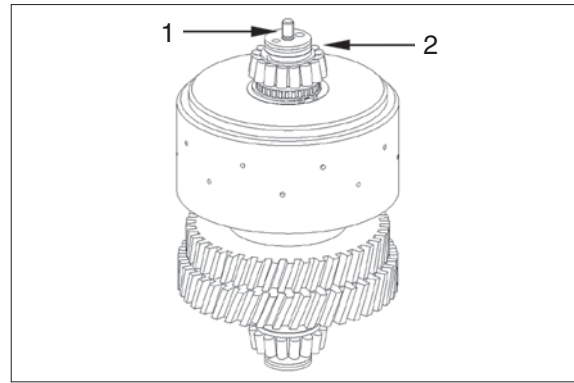

7609ATM196

- ※ Check closing and opening of the clutch by means of compressed air at the hole (see arrow).  
Closing and opening of the clutch must be clearly audible.

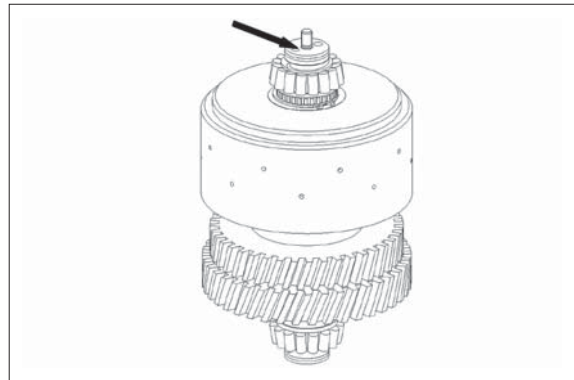

7609ATM197

② Install sealing cap-orifice- (1).

- ※ Wet contact surface with loctite (Type No. 262).

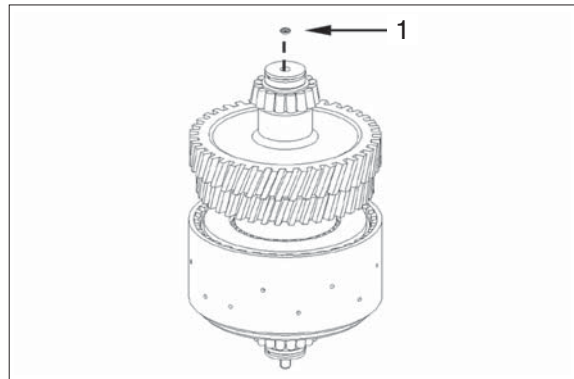

7609ATM198

### (3) Clutch K1

- ① Heat up bearing inner ring (approx. 120°C)

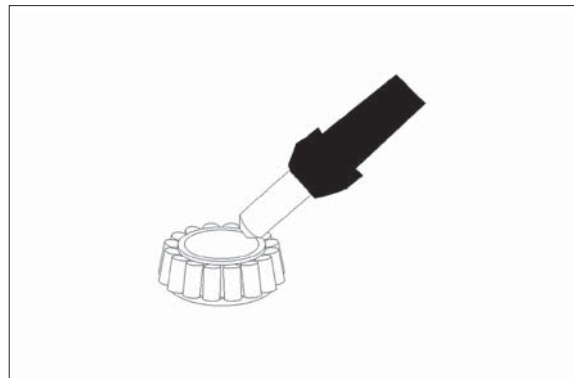

7609ATM199

- ② Mount bearing inner ring (1) until contact is obtained.

Fit rectangular ring  $40 \times 2.5$  (2).

- ※ Wear protective gloves.
- ※ Adjust bearing inner ring after cooling-down.

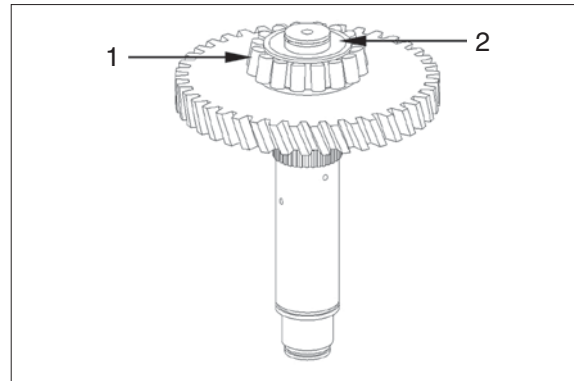

7609ATM200

- ③ Place both O-rings (1 and 2) into the piston grooves and oil them.

1  $75 \times 3$

2  $158 \times 3$

- ※ Check function of the drain valve (see arrow) - There must be no jamming of the ball.

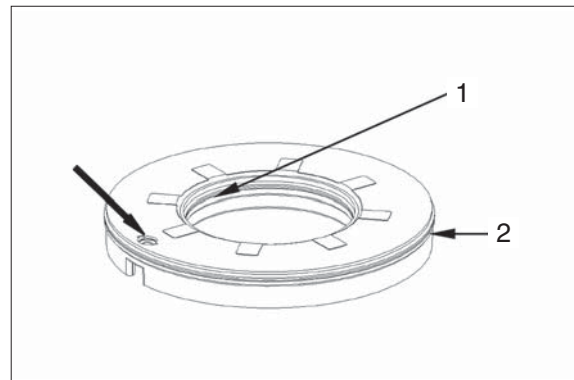

7609ATM201

- ④ Place piston (1) into the disk carrier.

- ※ Observe installation position, see figure.

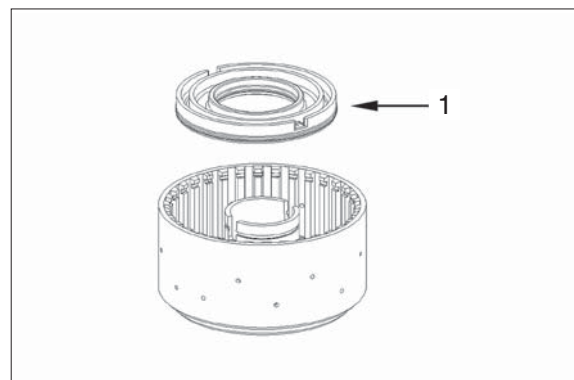

7609ATM202

- ⑤ Use a hand-operated press to place piston into the disk carrier by means of the assembly aid.

Assembly aid

5870 345 088

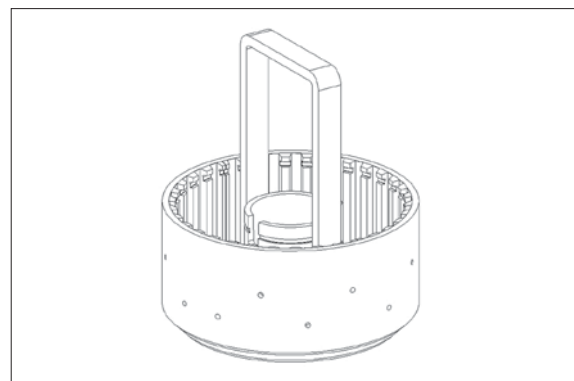

7609ATM203

- ⑥ Mount inner installer (S) onto the disk carrier.

Install cup spring package (1) and L-ring (2).

- ※ Installation position cup spring package and L-ring see figure TM206.

Inner installer see figure TM205

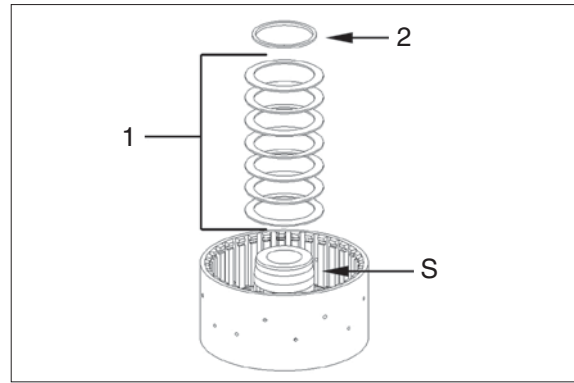

7609ATM204

- ⑦ Preload cup spring package by means of assembly aid (S1) and pressure piece (S2), until L-ring has engaged into the annular groove.

Assembly aid (S1) 5870 345 088

Assembly fixture (S + S2) 5870 345 124  
(Inner installer and pressure piece)

- ※ It is always necessary to mount a new L-ring.

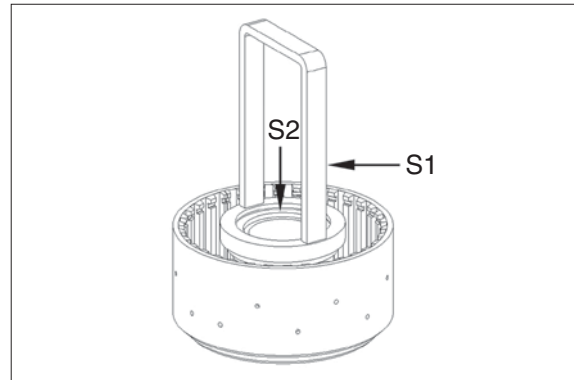

7609ATM205

Disk carrier with piston retraction :

- 1 Cup spring package
- 2 L-ring
- 3 Disk carrier
- 4 Piston with O-rings

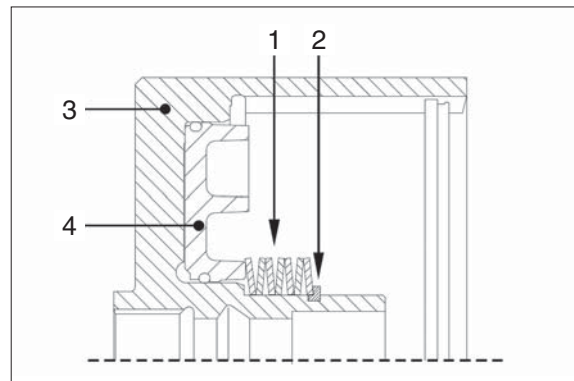

7609ATM206

- ⑧ Install outer and inner disks alternately into the disk carrier (4) as personated in figure TM207.

- 1 Friction disk-coated on one side (1 pcs)
- 2 Outer disks (9 pcs)
- 3 Inner disks (9 pcs)

- ※ Take care that the uncoated (blank) side of the friction disk (1) is showing towards the piston.

Number of friction surfaces : 18

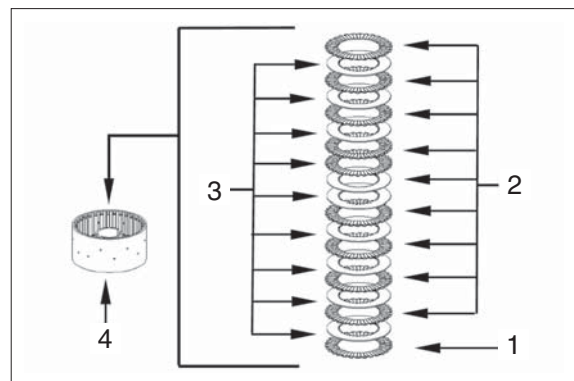

7609ATM207

- ⑨ Mount end plate (1) and fix disk package by means of snap ring (2) (e.g. thickness = 2.65 mm / recommended value).

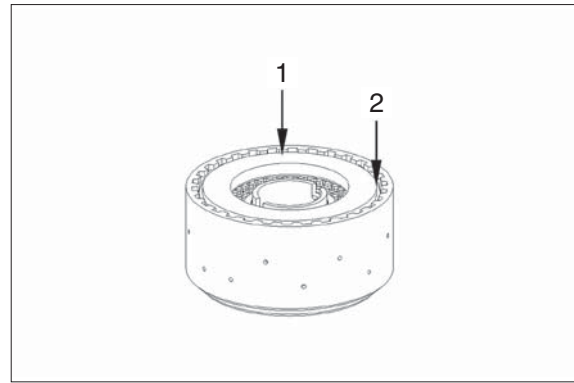

7609ATM208

- ⑩ Press on end plate with F (approx. 100 N = 10 kg) and set dial indicator to "zero".

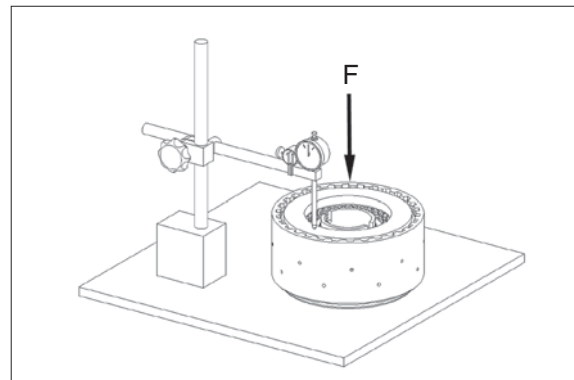

7609ATM209

- ⑪ Then press end plate against the snap ring (upwards) and read disk clearance.

- ※ Disk clearance : 2.35~2.65 mm
- ※ In case of deviations, the disk clearance must be corrected with an appropriate snap ring (optional thicknesses = 2.1~4.2 mm).

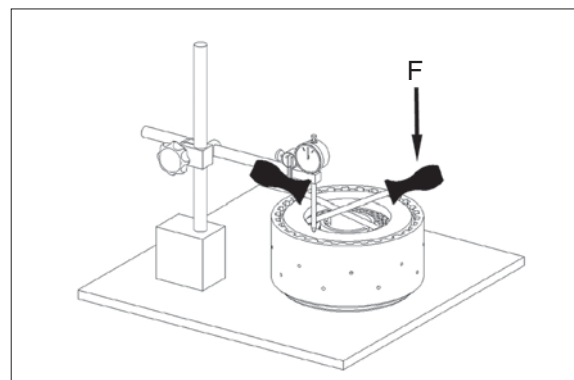

7609ATM210

- ⑫ Heat up clutch inner diameter (approx. 120°C).



7609ATM211

⑬ Mount clutch (1) until contact is obtained.

※ Wear protective gloves.

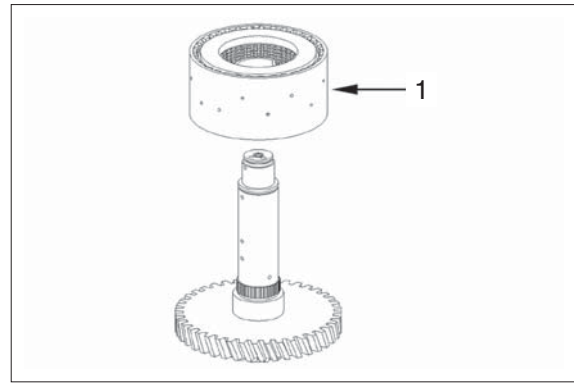

7609ATM212

⑭ Mount running disk  $55 \times 78 \times 5$  (1), axial cage  $55 \times 78 \times 3$  (2) and axial washer  $55 \times 78 \times 1$  (3) and oil it.

※ Install chamfer (see arrow) of running disk (1) showing towards the axial cage.

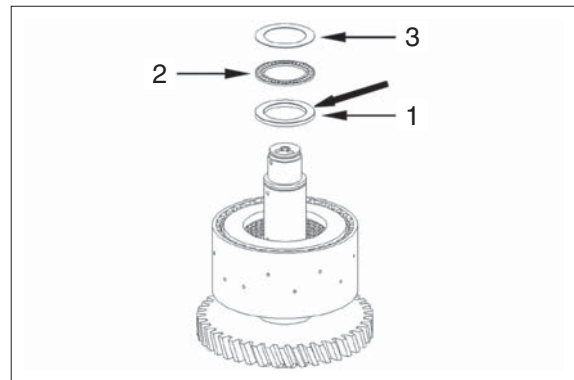

7609ATM213

⑮ Mount needle cage  $55 \times 63 \times 64$  (1) and oil it.

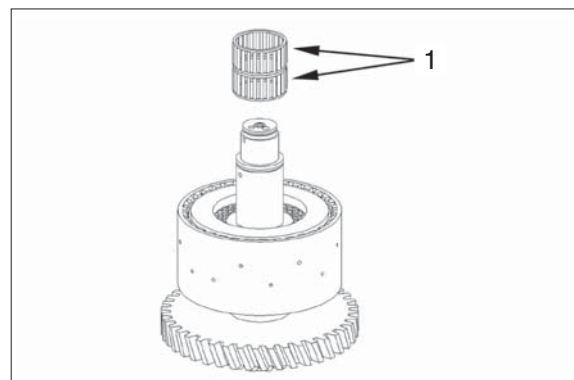

7609ATM214

⑯ Install (1) idler.

Mount inner disks onto the inner disk carrier (idler) by means of short left/right rotations.

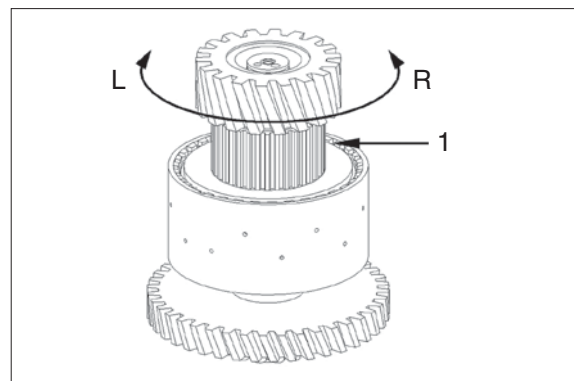

7609ATM215



- ⑰ Mount axial washer 55×78×1 (1), axial cage 55×78×3 (2) and running disk 55×78×5 (3) and oil it.

※ Install chamfer (see arrow) of running disk (3) showing towards the axial cage.

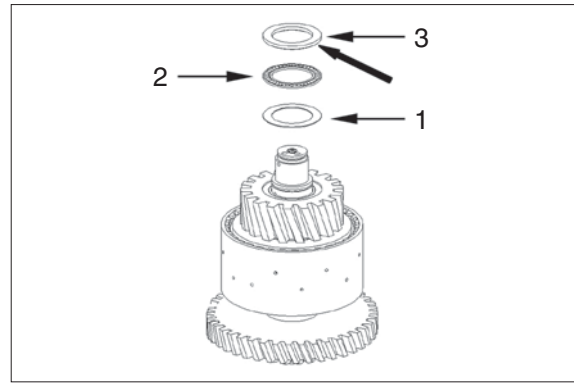

7609ATM216

- ⑱ Fix idler gear (1) and single parts by means of retaining ring (2).

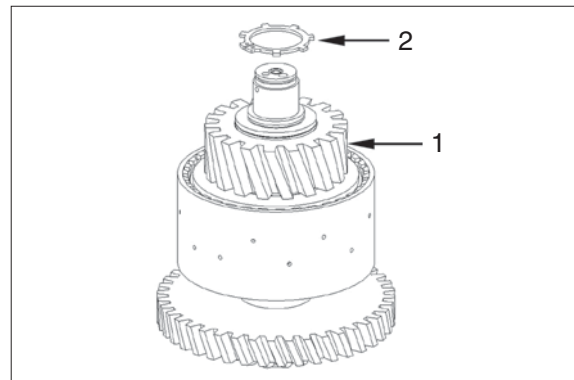

7609ATM217

- ⑲ Heat up bearing inner ring (approx. 120°C).

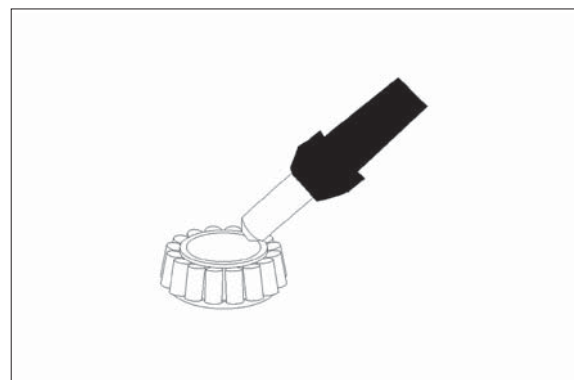

7609ATM218

- ⑳ Mount bearing inner ring (1) until contact is obtained.

※ Wear protective gloves.

※ Adjust bearing inner ring after cooling-down.

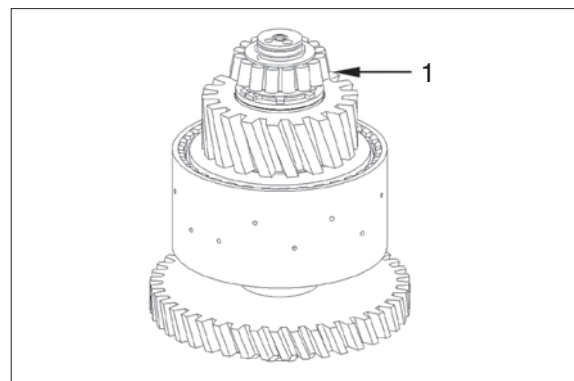

7609ATM219

② Mount stud bolt (1).

- Tightening torque (M10/8.8×16) :  
1.73 kgf · m (12.5 lbf · ft)

Fit rectangular ring 40×2.5 (2).

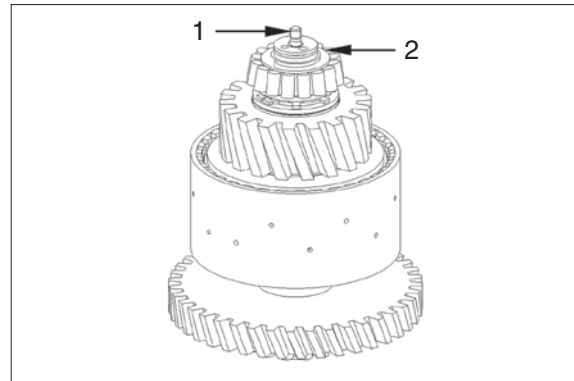

7609ATM220

- ※ Check closing and opening of the clutch by means of compressed air at the hole (see arrow).  
Closing and opening of the clutch must be clearly audible.

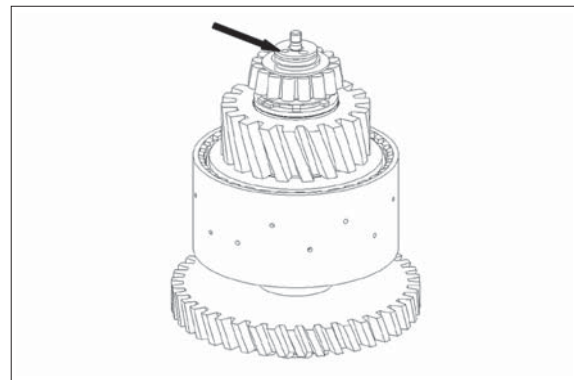

7609ATM221

#### (4) Clutch K2

① Heat up bearing inner ring (approx. 120°C)

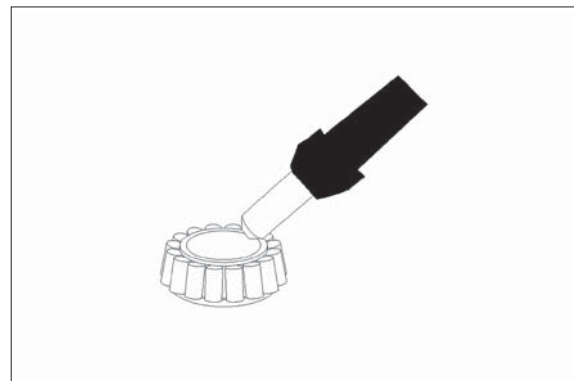

7609ATM222

② Mount bearing inner ring (1) until contact is obtained.

Fit rectangular ring 40×2.5 (2).

- ※ Wear protective gloves.
- ※ Adjust bearing inner ring after cooling-down.

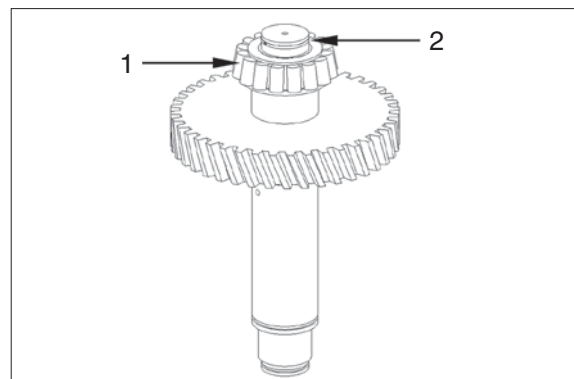

7609ATM223

- ③ Place both O-rings (1 and 2) into the piston grooves and oil them.

- 1 75×3  
2 142×3

- ※ Check function of the drain valve (see arrow) - There must be no jamming of the ball.

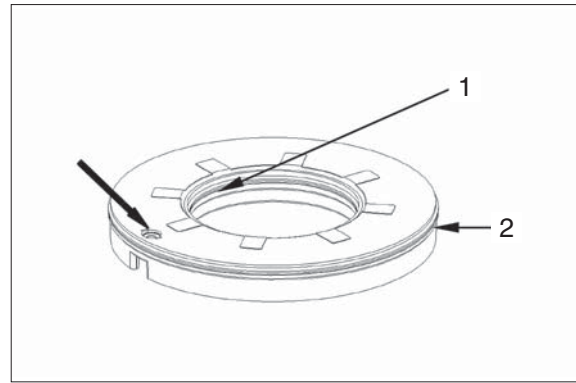

7609ATM224

- ④ Place piston (1) into the disk carrier.

- ※ Observe installation position, see figure.

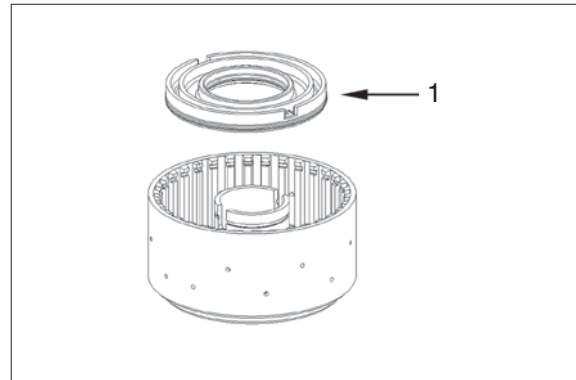

7609ATM225

- ⑤ Use a hand-operated press to place piston into the disk carrier by means of the assembly aid.

Assembly aid 5870 345 088

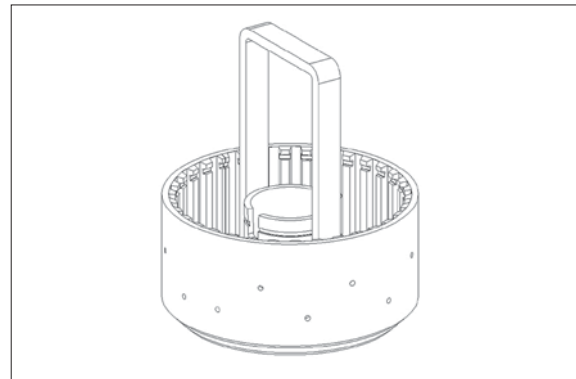

7609ATM226

- ⑥ Mount inner installer (S) onto the disk carrier.

Install cup spring package (1) and L-ring (2).

- ※ Installation position cup spring package and L-ring see figure TM229.

Inner installer see figure TM228

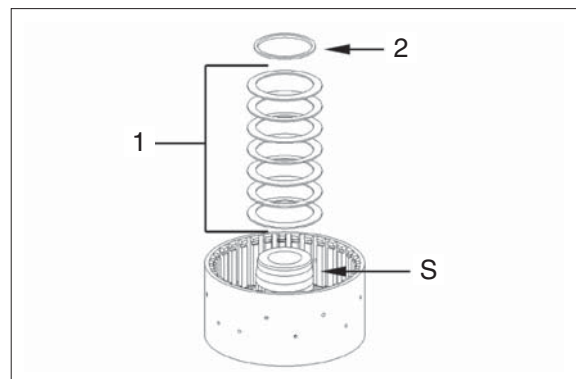

7609ATM227

- ⑦ Preload cup spring package by means of assembly aid (S1) and pressure piece (S2), until L-ring has engaged into the annular groove.

Assembly aid (S1)            5870 345 088  
 Assembly fixture (S + S2) 5870 345 124  
 (Inner installer and pressure piece)

- ※ It is always necessary to mount a new L-ring.

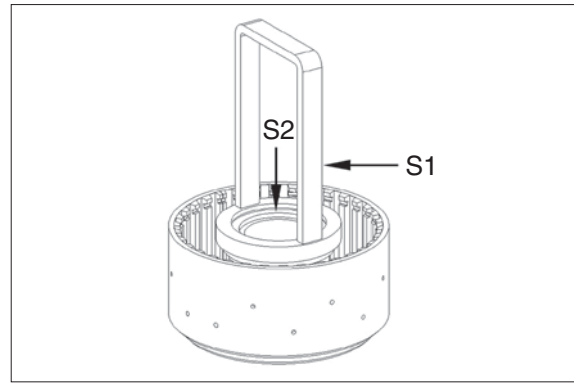

7609ATM228

Disk carrier with piston retraction :

- 1 Cup spring package
- 2 L-ring
- 3 Disk carrier
- 4 Piston with O-rings

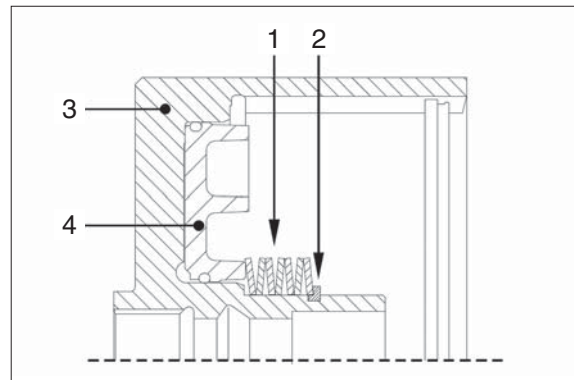

7609ATM229

- ⑧ Install outer and inner disks alternately into the disk carrier (4) as personated in figure TM230.

- 1 Friction disk-coated on one side (1 pcs)
- 2 Outer disks (7 pcs)
- 3 Inner disks (7 pcs)

- ※ Take care that the uncoated (blank) side of the friction disk (1) is showing towards the piston.

Number of friction surfaces : 14

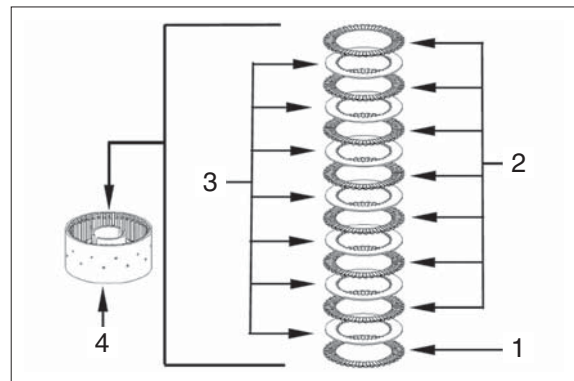

7609ATM230

- ⑨ Mount end plate (1) and fix disk package by means of snap ring (2) (e.g. thickness = 2.65 mm / recommended value).

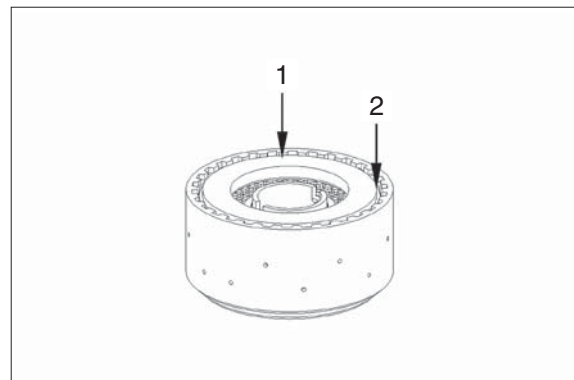

7609ATM231

- ⑩ Press on end plate with F (approx. 100 N = 10 kg) and set dial indicator to "zero".

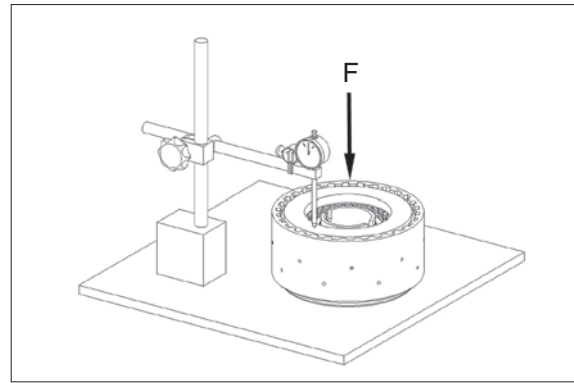

7609ATM232

- ⑪ Then press end plate against the snap ring (upwards) and read disk clearance.

- ※ Disk clearance : 1.75~2.05 mm  
(see figure TM230)
- ※ In case of deviations, the disk clearance must be corrected with an appropriate snap ring (optional thicknesses = 2.1~4.2 mm).

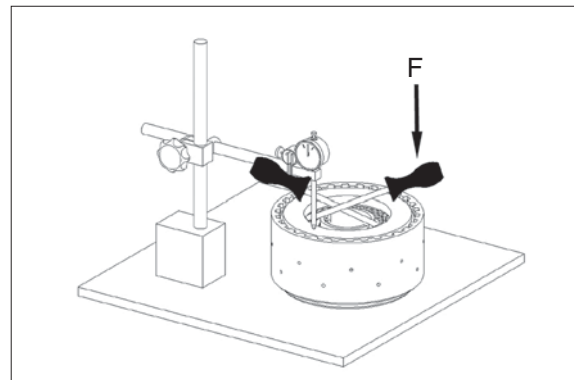

7609ATM233

- ⑫ Heat up clutch inner diameter (approx. 120°C).

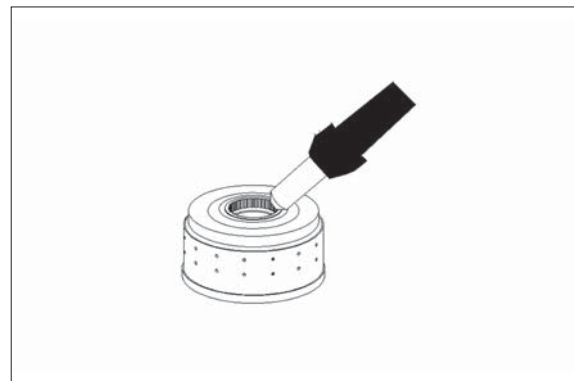

7609ATM234

- ⑬ Mount clutch (1) until contact is obtained.

- ※ Wear protective gloves.

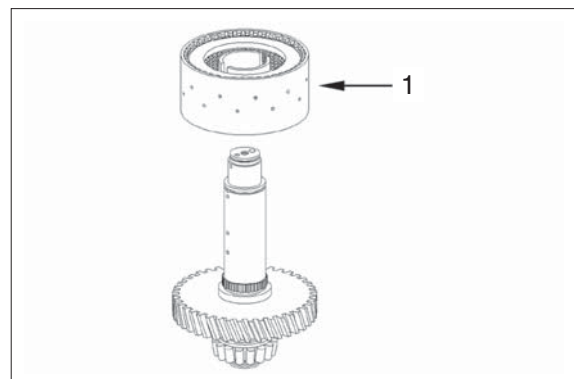

7609ATM235

- ⑭ Mount running disk  $55 \times 78 \times 5$  (1), axial cage  $55 \times 78 \times 3$  (2) and axial washer  $55 \times 78 \times 1$  (3) and oil it.

※ Install chamfer (see arrow) of running disk (1) showing towards the axial cage.

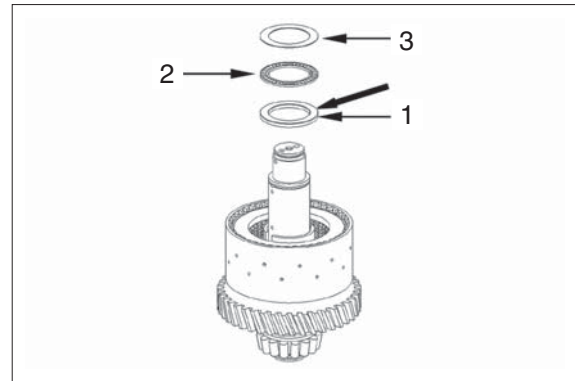

7609ATM236

- ⑮ Mount needle cage  $55 \times 63 \times 50$  (1) and oil it.

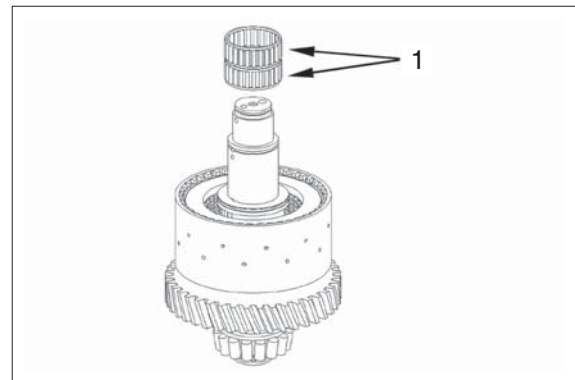

7609ATM237

- ⑯ Install (1) idler.

Mount inner disks onto the inner disk carrier (idler) by means of short left/right rotations.

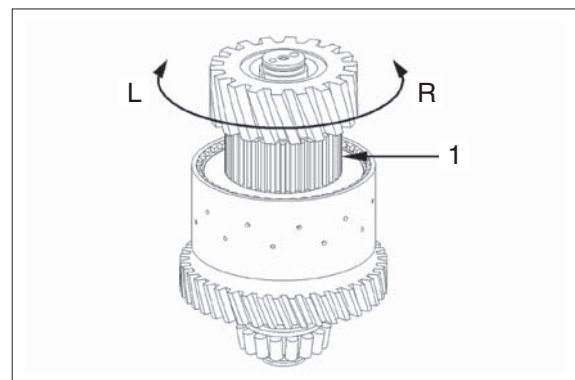

7609ATM238

- ⑰ Mount axial washer  $55 \times 78 \times 1$  (1), axial cage  $55 \times 78 \times 3$  (2) and running disk  $55 \times 78 \times 5$  (3) and oil it.

※ Install chamfer (see arrow) of running disk (3) showing towards the axial cage.

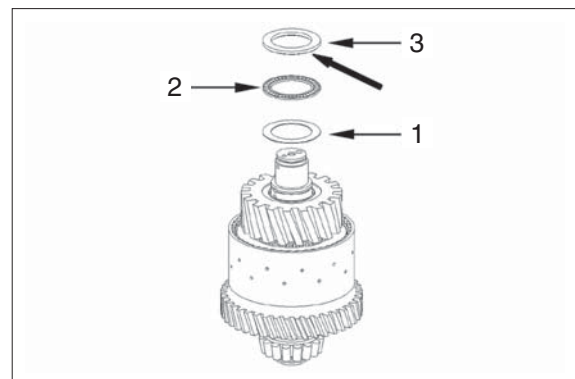

7609ATM239

- ⑱ Fix idler gear (1) and single parts by means of retaining ring (2).

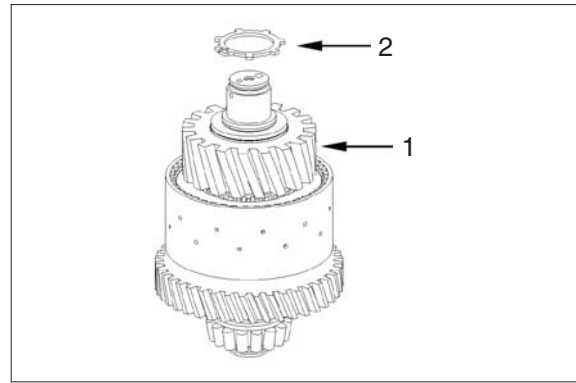

7609ATM240

- ⑲ Heat up bearing inner ring (approx. 120°C).

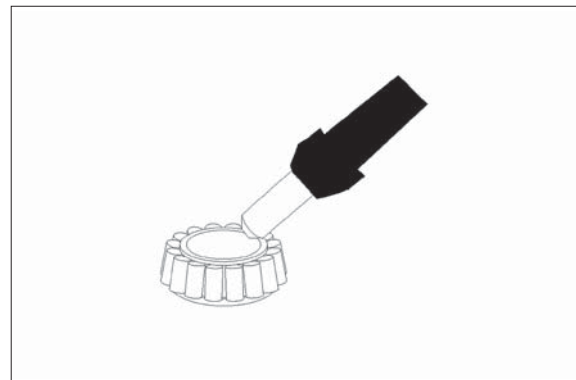

7609ATM241

- ⑳ Mount bearing inner ring (1) until contact is obtained.

- ※ Wear protective gloves.
- ※ Adjust bearing inner ring after cooling-down.

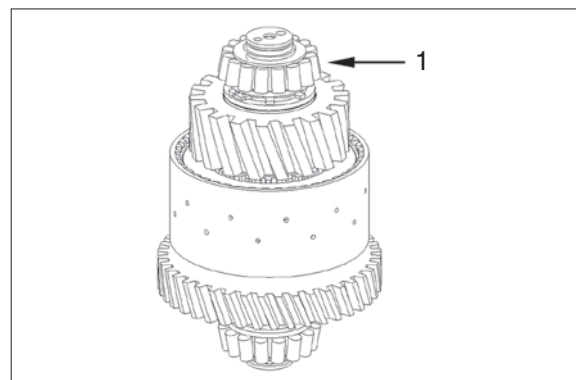

7609ATM242

- ㉑ Mount stud bolt (1).

- Tightening torque (M10/8.8×16) :  
1.73 kgf · m (12.5 lbf · ft)

Fit rectangular ring 40×2.5 (2).

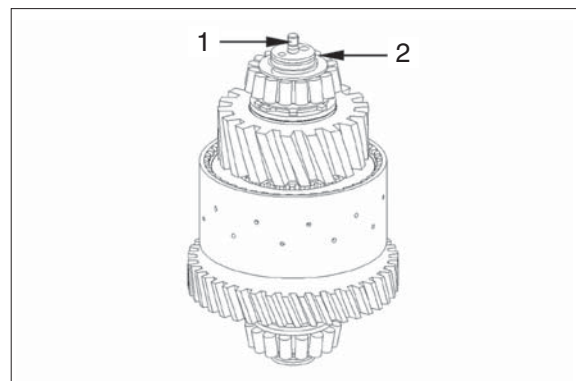

7609ATM243

- ※ Check closing and opening of the clutch by means of compressed air at the hole (see arrow).  
Closing and opening of the clutch must be clearly audible.

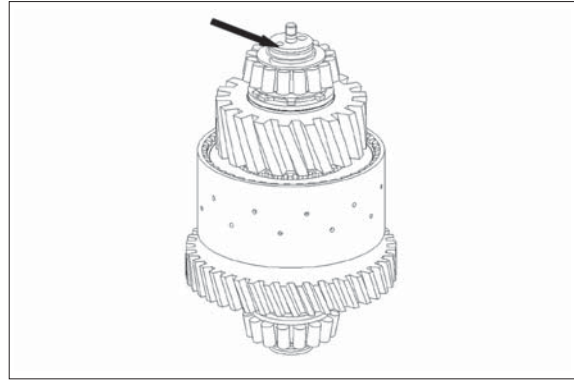

7609ATM244

### (5) Clutch K3

- ① Heat up bearing inner ring (approx. 120°C)

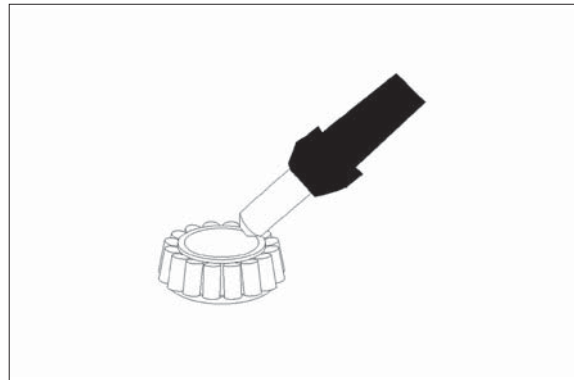

7609ATM245

- ② Mount bearing inner ring (1) until contact is obtained.

Fit rectangular ring 40 × 2.5 (2).

- ※ Wear protective gloves.
- ※ Adjust bearing inner ring after cooling-down.

Mount stud bolt (3).

- Tightening torque (M10/8.8 × 16) :  
1.73 kgf · m (12.5 lbf · ft)

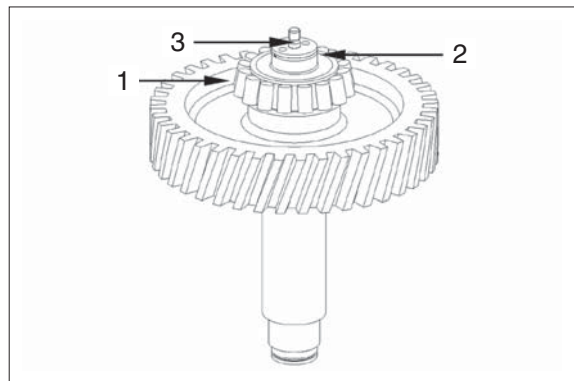

7609ATM246

- ③ Place both O-rings (1 and 2) into the piston grooves and oil them.

- 1 75 × 3
- 2 142 × 3

- ※ Check function of the drain valve (see arrow) - There must be no jamming of the ball.

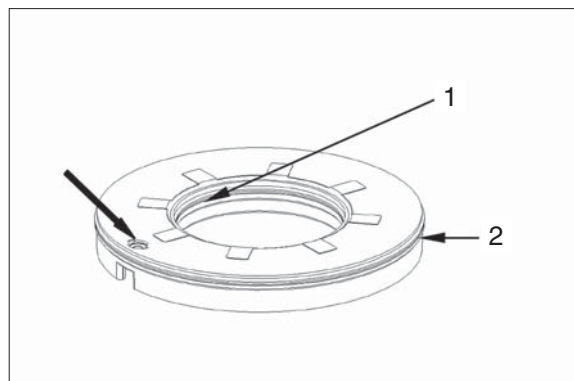

7609ATM247



④ Place piston (1) into the disk carrier.

※ Observe installation position, see figure.

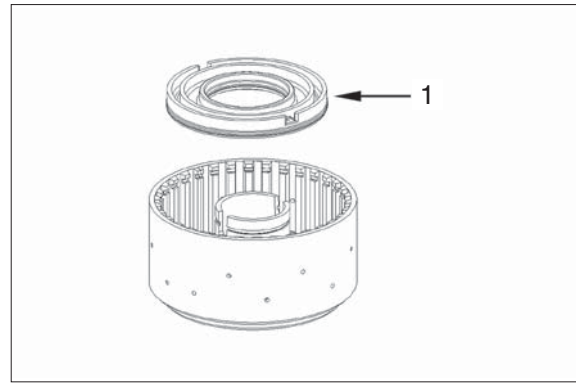

7609ATM248

⑤ Use a hand-operated press to place piston into the disk carrier by means of the assembly aid.

Assembly aid                      5870 345 088

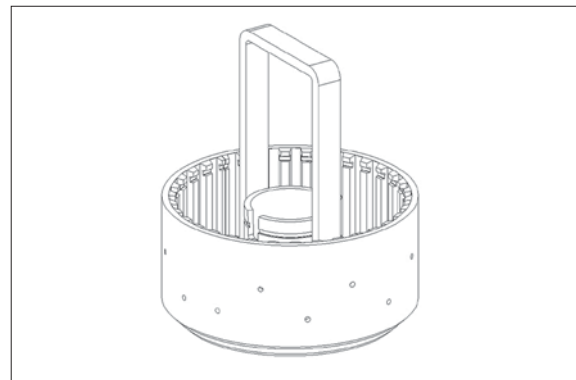

7609ATM249

⑥ Mount inner installer (S) onto the disk carrier.

Install cup spring package (1) and L-ring (2).

※ Installation position cup spring package and L-ring see figure TM252.

Inner installer                      see TM251

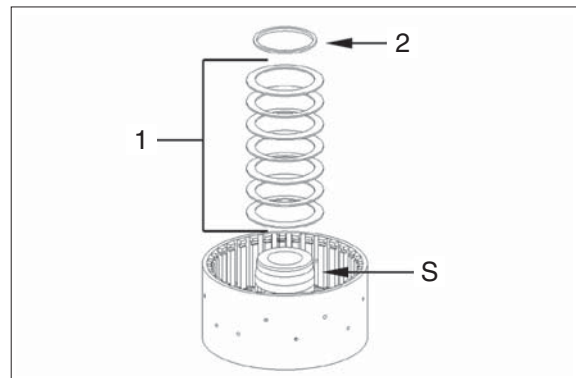

7609ATM250

⑦ Preload cup spring package by means of assembly aid (S1) and pressure piece (S2), until L-ring has engaged into the annular groove.

Assembly aid (S1)                      5870 345 088  
Assembly fixture (S + S2) 5870 345 124  
(Inner installer and pressure piece)

※ It is always necessary to mount a new L-ring.

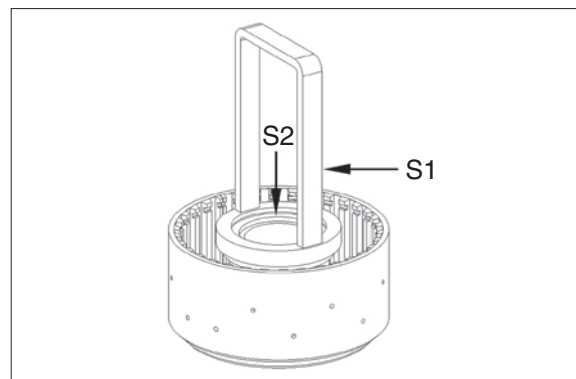

7609ATM251

Disk carrier with piston retraction :

- 1 Cup spring package
- 2 L-ring
- 3 Disk carrier
- 4 Piston with O-rings

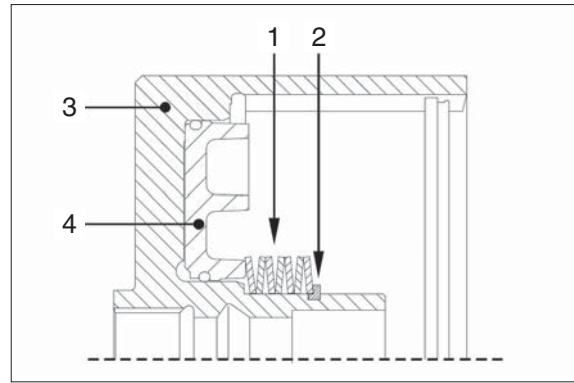

7609ATM252

- ※ Different clutches (disc arrangements with relevant disc clearance) can be installed, depending on the parts manual.
- ※ The actually installed clutch and disc arrangement must be taken from the corresponding parts manual.
- ※ Figure no. : TM253 and TM254 illustrates the different disc arrangements.

⑧ Install outer and inner disks alternately into the disk carrier (4) as personated in figure TM253.

- 1 Friction disk-coated on one side (1 pcs)
- 2 Outer disks (7 pcs)
- 3 Inner disks (7 pcs)

※ Take care that the uncoated (blank) side of the friction disk (1) is showing towards the piston.

Number of friction surfaces : 14

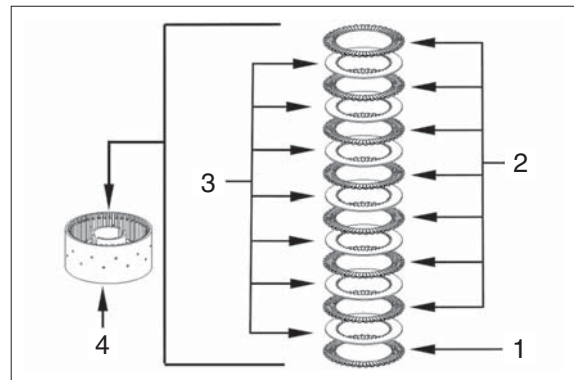

7609ATM253

⑨ Install outer and inner disks alternately into the disk carrier (4) as personated in figure TM254.

- 1 Friction disk-coated on one side (1 pcs)
- 2 Outer disks (7 pcs)
- 3 Inner disks (7 pcs)

Take care that the uncoated (blank) side of the friction disk (1) is showing towards the piston.

Number of friction surfaces : 12

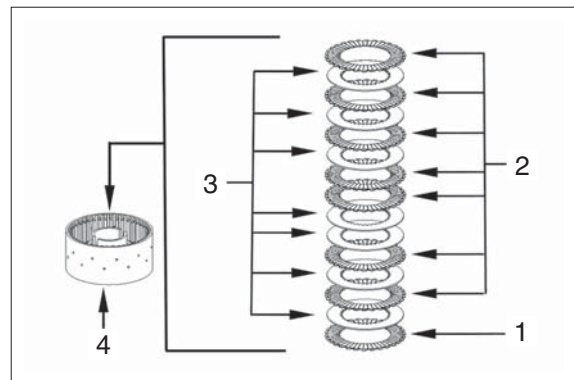

7609ATM254

- ⑩ Mount end plate (1) and fix disk package by means of snap ring (2) (e.g. thickness = 2.65 mm / recommended value).

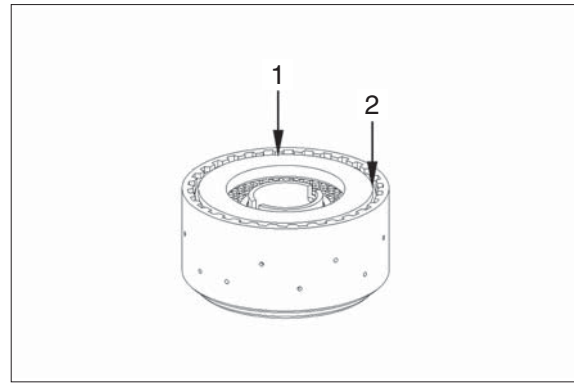

7609ATM255

- ⑪ Press on end plate with F (approx. 100 N = 10 kg) and set dial indicator to "zero".

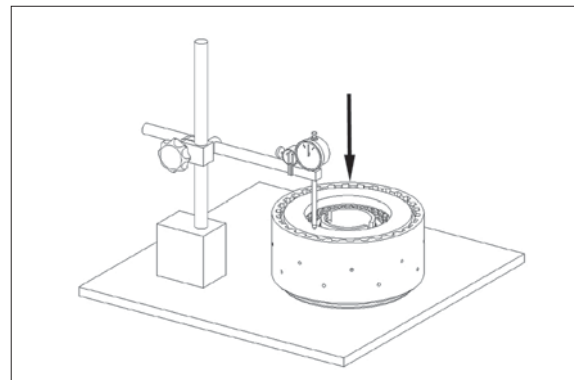

7609ATM256

- ⑫ Then press end plate against the snap ring (upwards) and read disk clearance.

- ※ Disk clearance : 1.75~2.05 mm
- ※ In case of deviations, the disk clearance must be corrected with an appropriate snap ring (optional thicknesses = 2.1~4.2 mm).

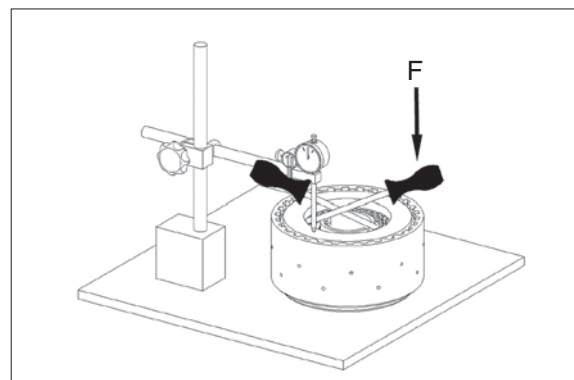

7609ATM257

- ⑬ Heat up clutch inner diameter (approx. 120°C)



7609ATM258

⑭ Mount clutch (1) until contact is obtained.

※ Wear protective gloves.

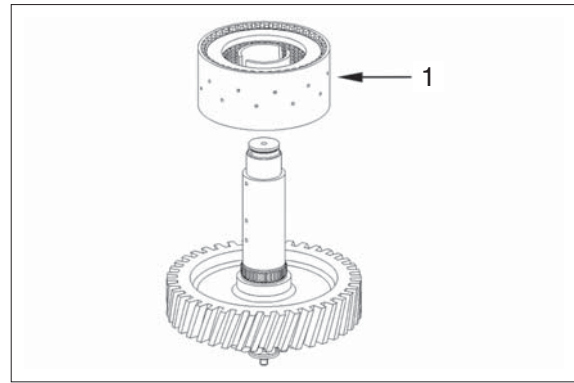

7609ATM259

⑮ Mount running disk  $55 \times 78 \times 5$  (1), axial cage  $55 \times 78 \times 3$  (2) and axial washer  $55 \times 78 \times 1$  (3) and oil it.

※ Install chamfer (see arrow) of running disk (1) showing towards the axial cage.

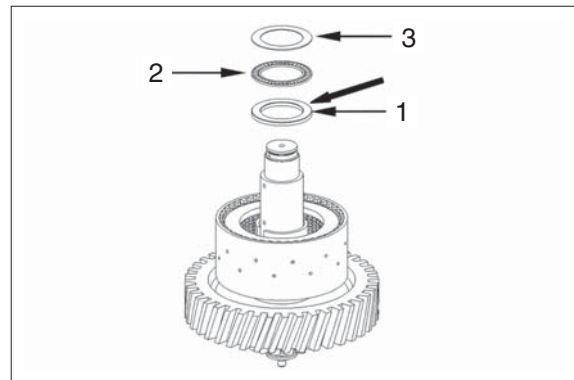

7609ATM260

⑯ Mount needle cage  $55 \times 63 \times 50$  (1) and oil it.

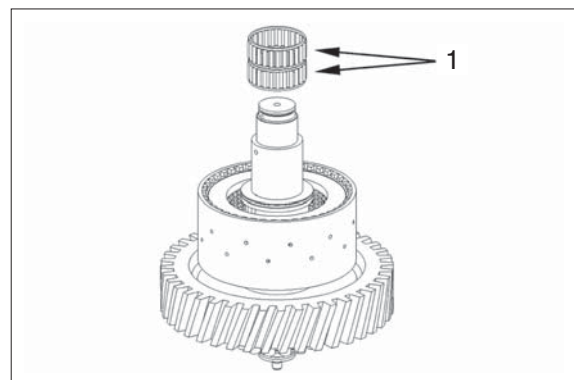

7609ATM261

⑰ Install (1) idler.

Mount inner disks onto the inner disk carrier (idler) by means of short left/right rotations.

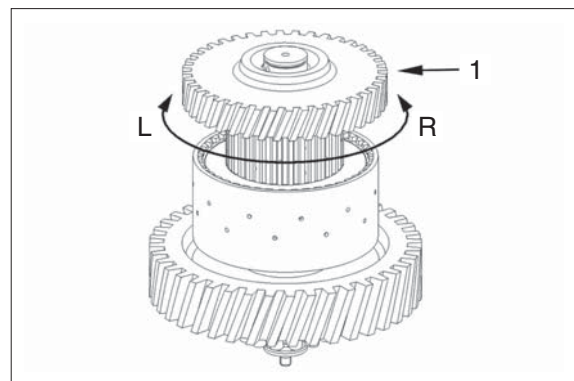

7609ATM262

⑱ Mount axial washer  $55 \times 78 \times 1$  (1), axial cage  $55 \times 78 \times 3$  (2) and running disk  $55 \times 78 \times 5$  (3) and oil it.

※ Install chamfer (see arrow) of running disk (3) showing towards the axial cage.

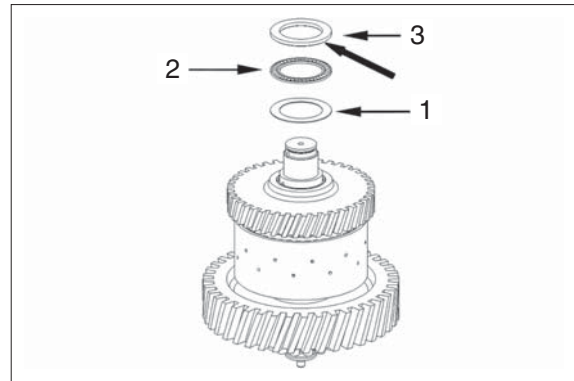

7609ATM263

※ Pay attention that the running disk is flush with the shaft (see arrow) collar to ensure that all inner disks are mounted on the idler gear teeth.

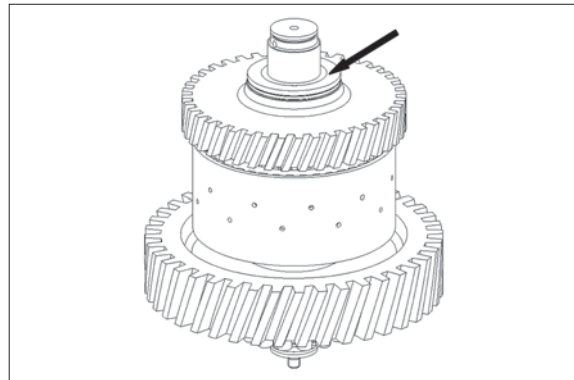

7609ATM264

⑲ Heat up bearing inner ring (approx.  $120^{\circ}\text{C}$ ).

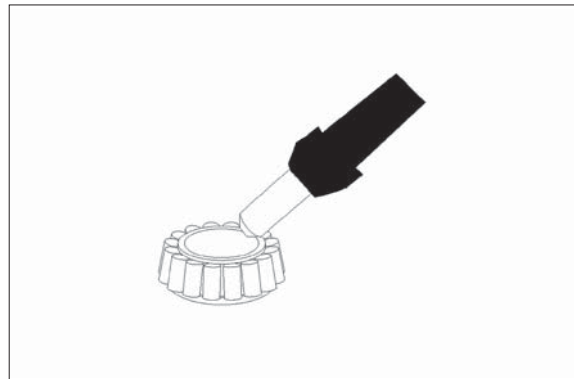

7609ATM265

⑳ Mount bearing inner ring (1) until contact is obtained.

Fit rectangular ring  $40 \times 2.5$  (2).

※ Wear protective gloves.

※ Adjust bearing inner ring after cooling-down.

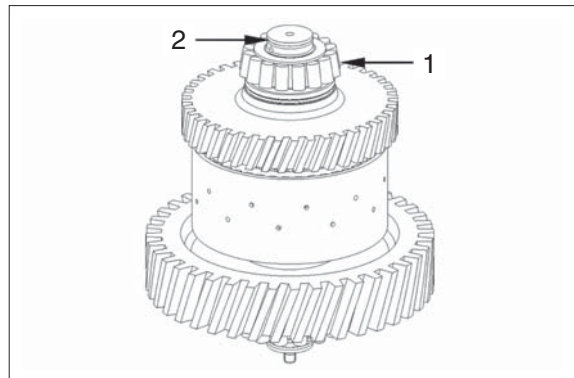

7609ATM266

- ※ Check closing and opening of the clutch by means of compressed air at the hole (see arrow).
- Closing and opening of the clutch must be clearly audible.

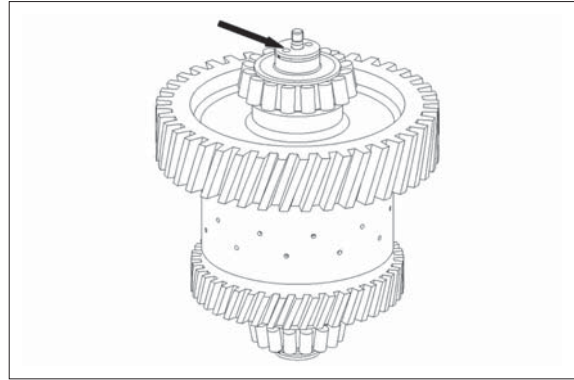

7609ATM267

## (6) K4 Clutch

- ① Heat up bearing inner ring (approx. 120°C)

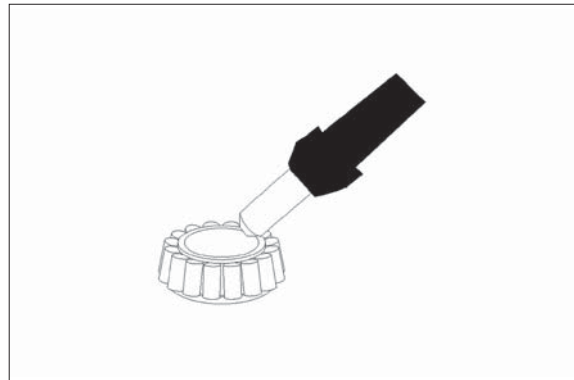

7609ATM268

- ② Mount bearing inner ring (1) until contact is obtained.

Fit rectangular ring 40 × 2.5 (2).

- ※ Wear protective gloves.
- ※ Adjust bearing inner ring after cooling-down.

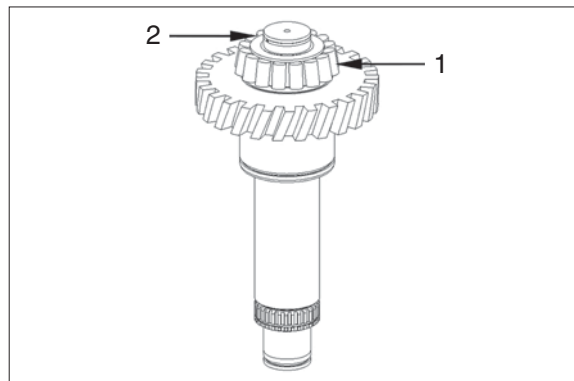

7609ATM269

- ③ Undercool shaft (1) (approx. -80°C), heat up gear (2) (approx. +120°C) and mount until contact is obtained.

- ※ Wear protective gloves.

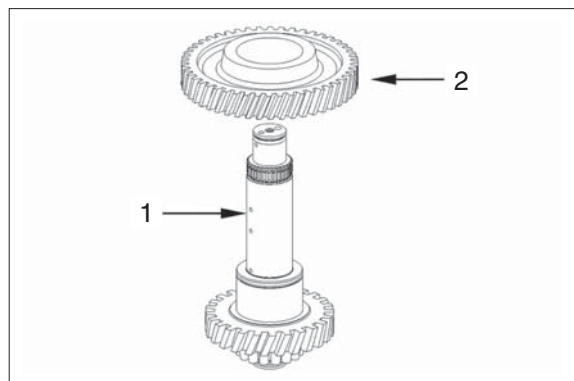

7609ATM270

- ④ Secure gear by means of retaining ring  $80 \times 2.5$  (1).

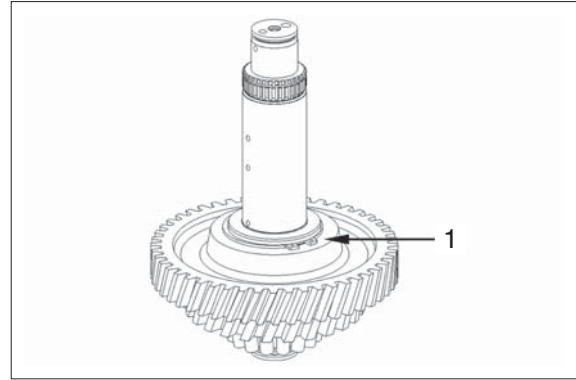

7609ATM271

- ⑤ Mount lower axial washer  $55 \times 78 \times 1$  (1), axial needle cage  $55 \times 78 \times 3$  (2) and upper axial washer  $55 \times 78 \times 1$  (1) and oil it.

※ Upper and lower axial washer are identical.

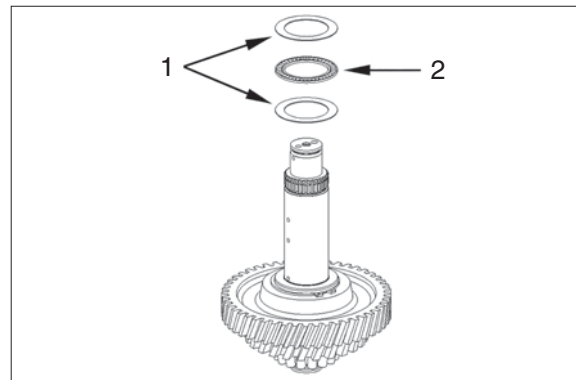

7609ATM272

- ⑥ Mount needle cage  $55 \times 63 \times 50$  (1) and oil it.

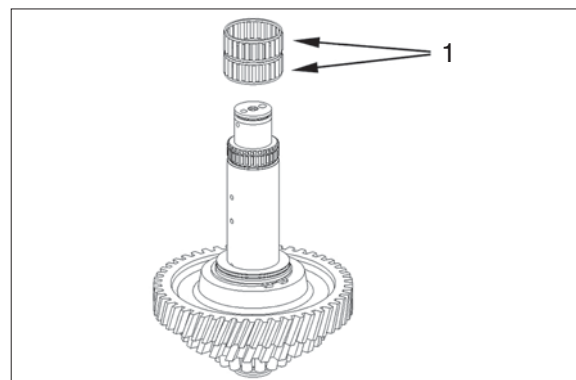

7609ATM273

- ⑦ Mount idler gear (1).

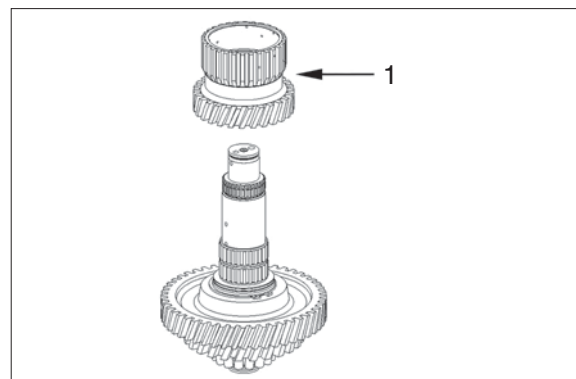

7609ATM274

- ⑧ Mount axial washer 55×78×1 (1), axial needle 55×78×3 cage (2) and running disk 55×78×5 (3) and oil it.

※ Mount running disk (3) with the chamfer (see arrow) showing to the needle cage.

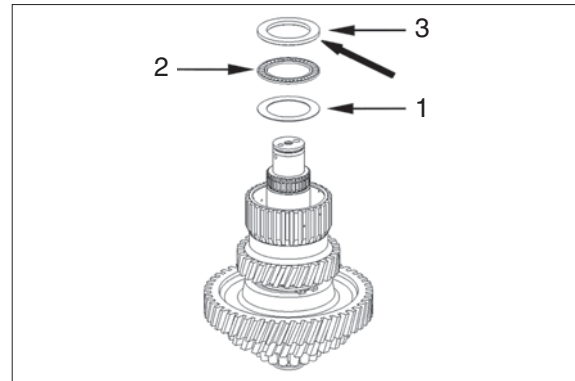

- ⑨ Place both O-rings (1 and 2) into the piston grooves and oil them.

1 75×3

2 142×3

※ Check function of the drain valve (see arrow) - There must be no jamming of the ball.

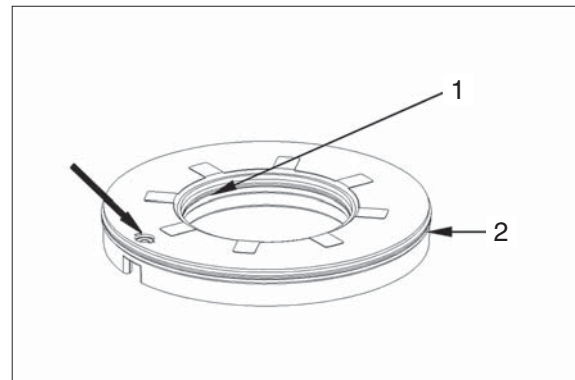

- ⑩ Place piston (1) into the disk carrier.

※ Observe installation position, see figure.

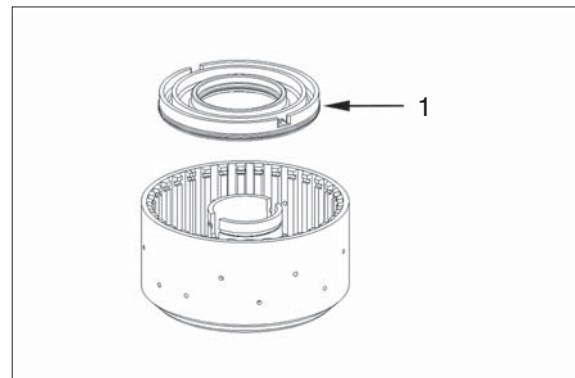

- ⑪ Use a hand-operated press to place piston into the disk carrier by means of the assembly aid.

Assembly aid

5870 345 088

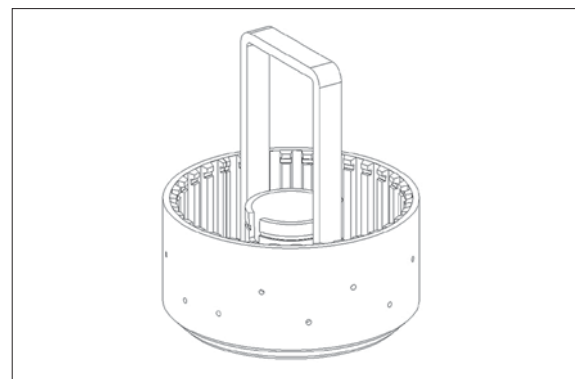



- ⑫ Mount inner installer (S) onto the disk carrier.

Install cup spring package (1) and L-ring (2).

- ※ Installation position cup spring package and L-ring see figure TM281.

Inner installer see figure TM280

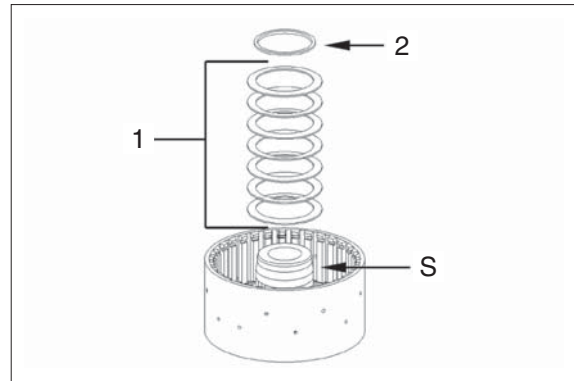

7609ATM279

- ⑬ Preload cup spring package by means of assembly aid (S1) and pressure piece (S2), until L-ring has engaged into the annular groove.

Assembly aid (S1) 5870 345 088

Assembly fixture (S + S2) 5870 345 124  
(Inner installer and pressure piece)

- ※ It is always necessary to mount a new L-ring.

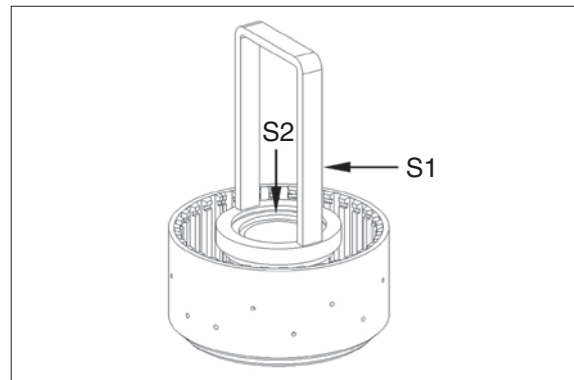

7609ATM280

Disk carrier with piston retraction :

- 1 Cup spring package
- 2 L-ring
- 3 Disk carrier
- 4 Piston with O-rings

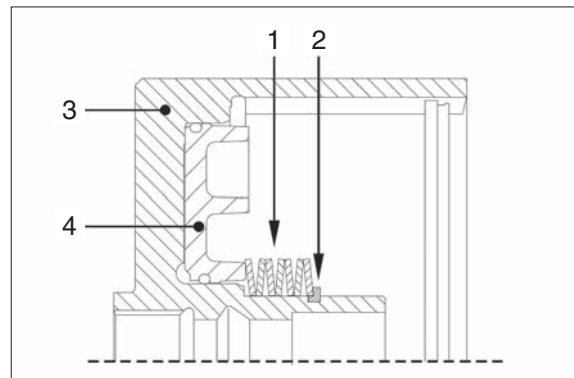

7609ATM281

- ⑭ Install outer and inner disks alternately into the disk carrier (4) as personated in figure TM282.

- 1 Friction disk -coated on one side (1 pcs)
- 2 Outer disks (6 pcs)
- 3 Inner disks (6 pcs)

- ※ Take care that the uncoated (blank) side of the friction disk (1) is showing towards the piston.

Number of friction surfaces : 12

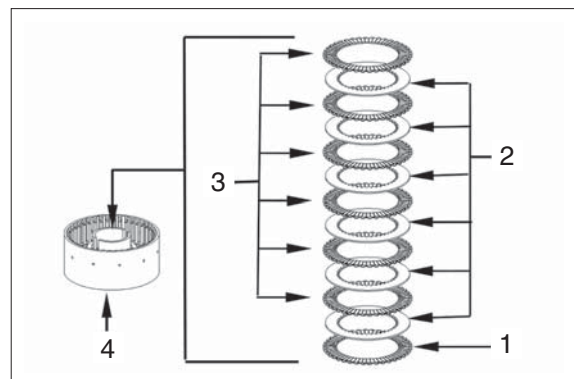

7609ATM282

- ⑮ Mount end plate (1) and fix disk package by means of snap ring (2) (e.g. thickness = 2.65 mm / recommended value).

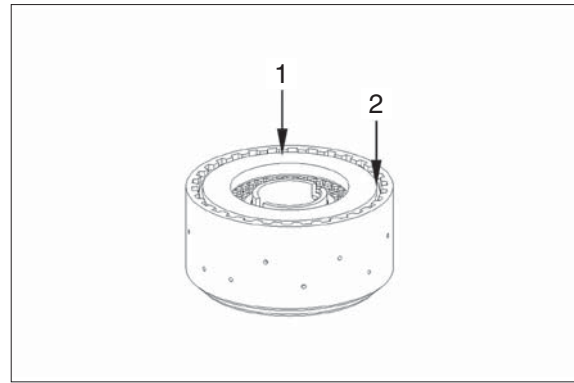

7609ATM283

- ⑯ Press on end plate with F (approx. 100 N = 10 kg) and set dial indicator to "zero".

Magnetic stand                    5870 200 055  
Dial indicator                    5870 200 057

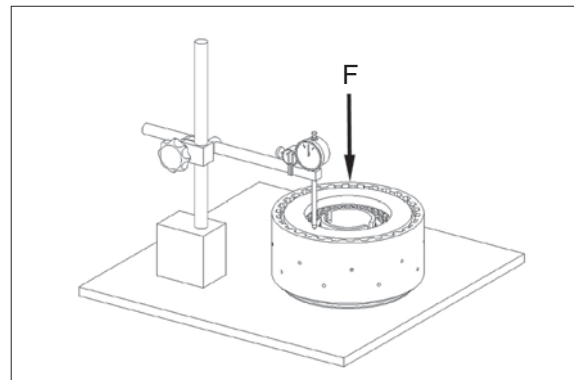

7609ATM284

- ⑰ Then press end plate against the snap ring (upwards) and read disk clearance.

- ※ Disk clearance : 1.35~1.65 mm  
(see figure TM282)
- ※ In case of deviations, the disk clearance must be corrected with an appropriate snap ring (optional thicknesses = 2.1~4.2 mm).

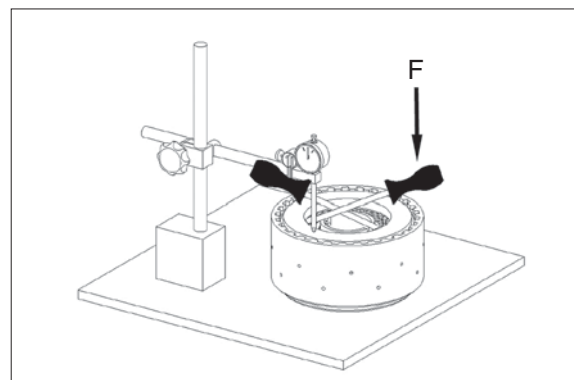

7609ATM285

- ⑱ Heat up bearing inner ring (approx. 120°C)



7609ATM286

⑲ Mount clutch (1) until contact is obtained.

Mount inner disks onto the inner disk carrier by means of short left/right rotations.

※ Wear protective gloves.

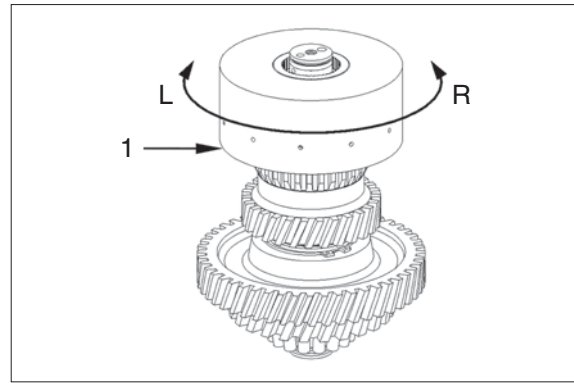

7609ATM287

⑳ Secure clutch by means of retaining ring 55×2 (1).

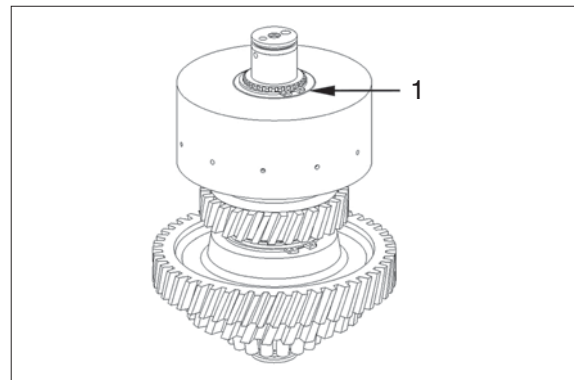

7609ATM288

㉑ Heat up bearing inner ring (approx. 120°C)



7609ATM289

㉒ Mount bearing inner ring (1) until contact is obtained.

※ Wear protective gloves.

※ Adjust bearing inner ring after cooling-down.

Fit rectangular ring 40×2.5 (2).

Mount stud bolt (3).

· Tightening torque (M10/8.8×16) :  
1.73 kgf · m (12.5 lbf · ft)

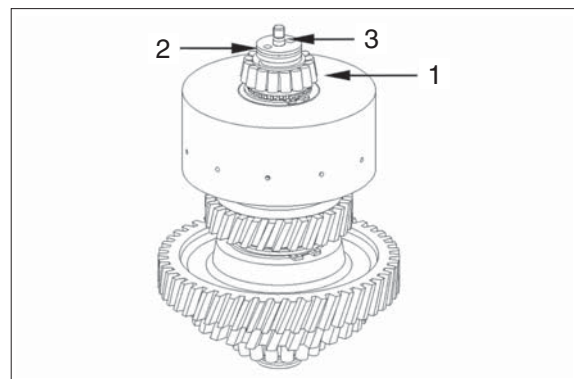

7609ATM290

- ※ Check closing and opening of the clutch by means of compressed air at the hole (see arrow).  
Closing and opening of the clutch must be clearly audible.

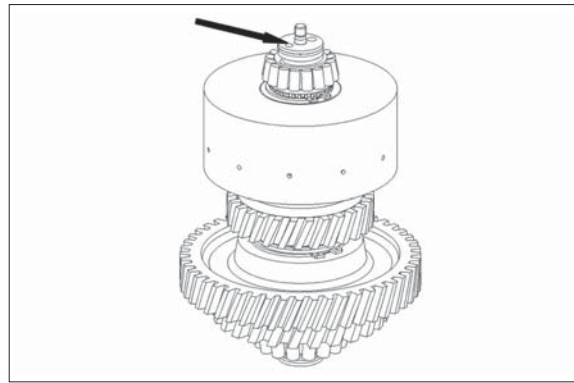

7609ATM291

### (7) Input shaft

- ① Undercool input shaft (1) (approx.  $-80^{\circ}\text{C}$ ), heat up drive gear (2) (approx.  $+120^{\circ}\text{C}$ ) and mount until contact is obtained.
- ※ Wear protective gloves.

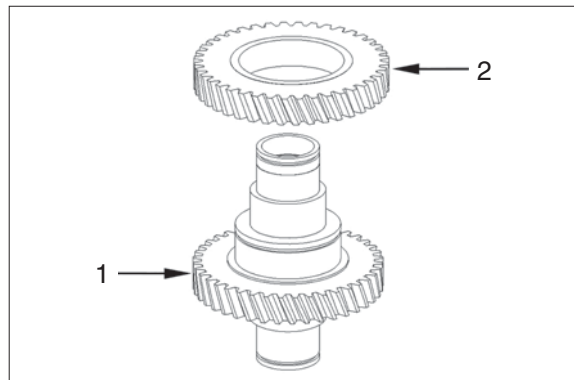

7609ATM292

- ② Secure drive gear by means of retaining ring 100×3 (1).

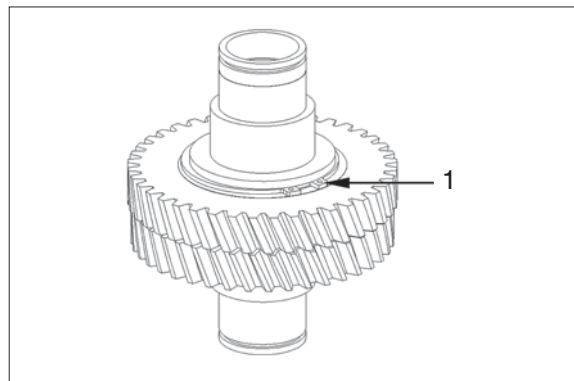

7609ATM293

- ③ Heat up bearing inner ring (approx.  $120^{\circ}\text{C}$ )

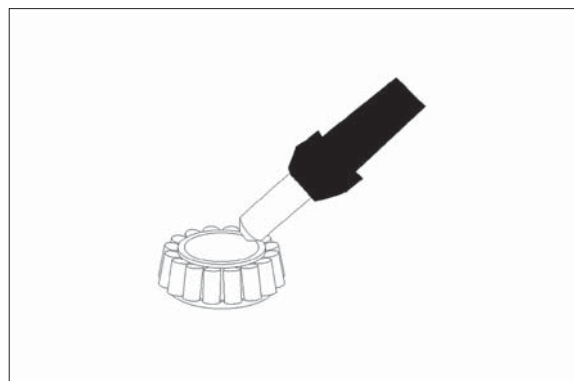

7609ATM294

④ Mount bearing inner ring (1) until contact is obtained.

※ Wear protective gloves.

※ Adjust bearing inner ring after cooling-down.

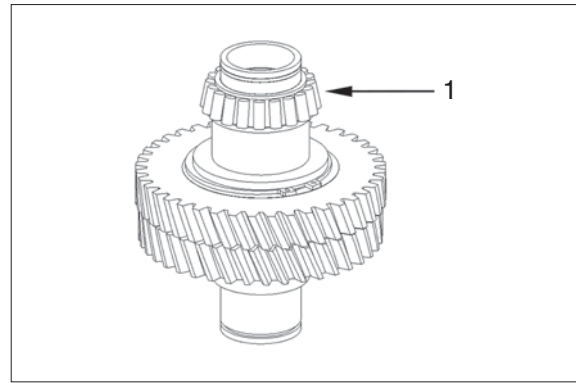

7609ATM295

⑤ Heat up bearing inner ring (approx. 120° C)

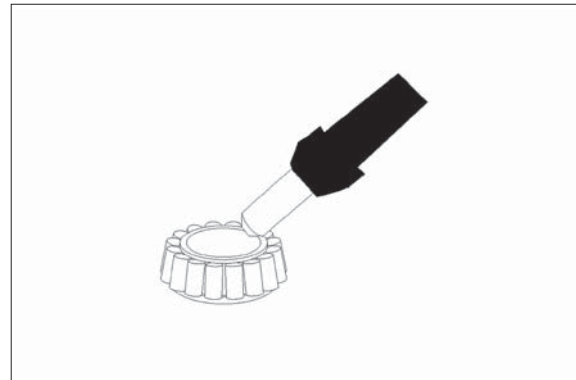

7609ATM296

⑥ Mount bearing inner ring (1) until contact is obtained.

※ Wear protective gloves.

※ Adjust bearing inner ring after cooling-down.

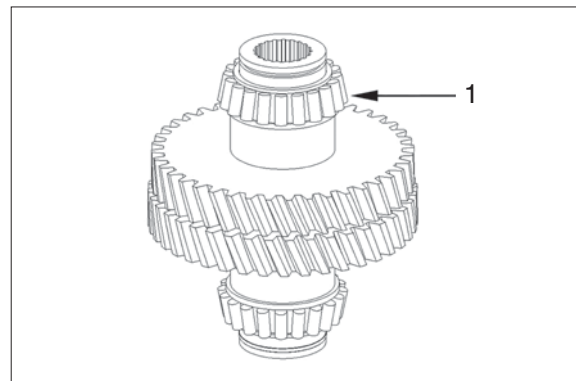

7609ATM297

⑦ Install snap ring (1) into the annular groove (2) of the turbine shaft.

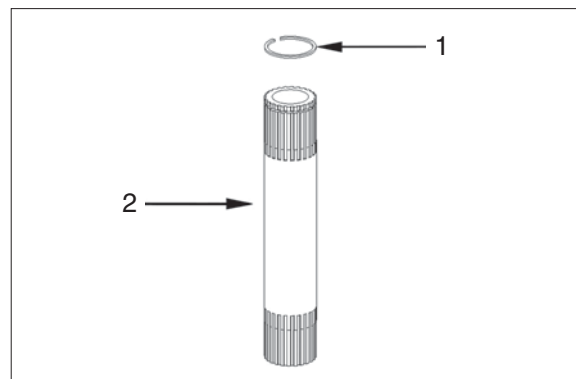

7609ATM298

⑧ Mount turbine shaft (1) until the snap ring engages into the input shaft groove.

※ Turbine shaft is axially fixed.

Snap in and interlock rectangular ring 60 × 3 (2).

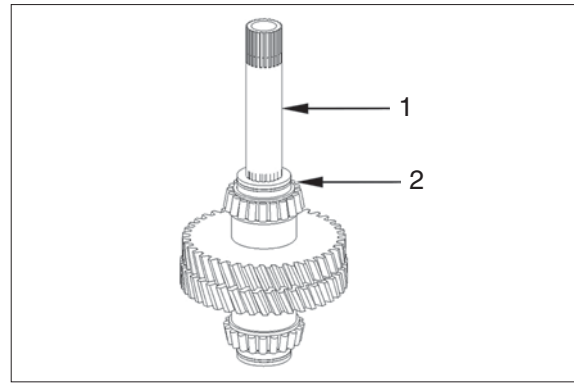

7609ATM299

### (8) Output shaft

① Heat up bearing inner ring (approx. 120°C)

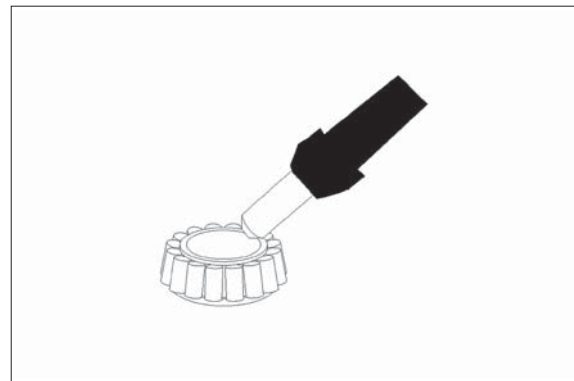

7609ATM301

② Mount bearing inner ring (1) until contact is obtained.

※ Wear protective gloves.

※ Adjust bearing inner ring after cooling-down.

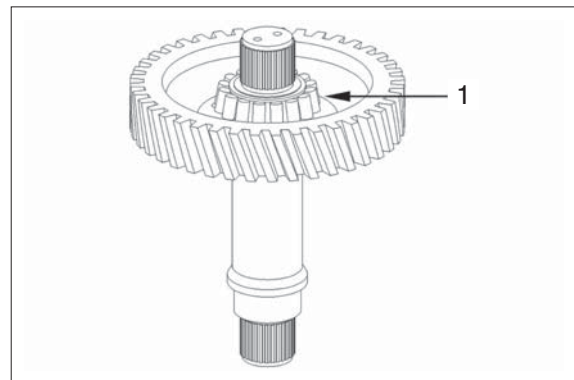

7609ATM302

③ Mount screen sheet (1).

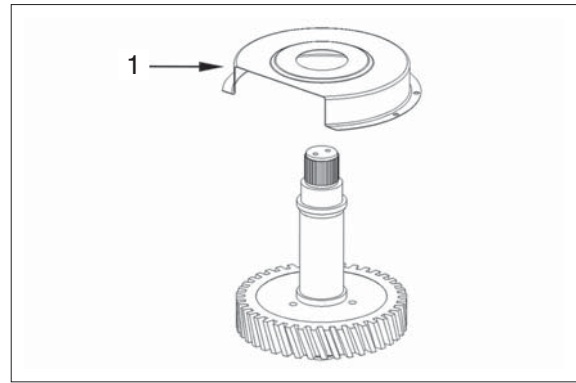

④ Heat up bearing inner ring (approx. 120°C)

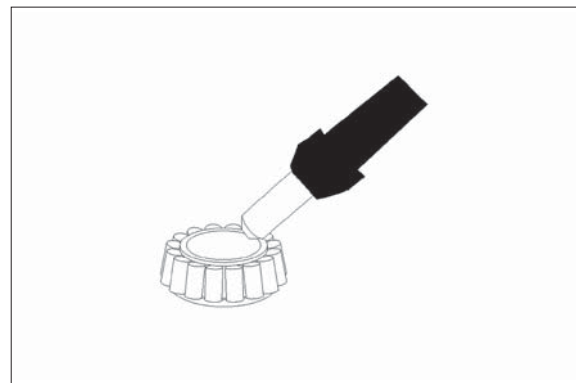

⑤ Mount bearing inner ring (1) until contact is obtained.

※ Wear protective gloves.

※ Adjust bearing inner ring after cooling-down.

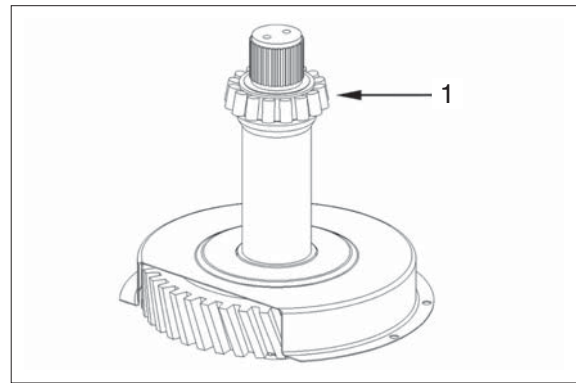

## 9) INSTALLATION OF INPUT SHAFT, OUTPUT SHAFT, PUMP SHAFT (POWER-TAKE OFF SHAFT) AND CLUTCHES

- (1) If the suction tube (1) in the housing front part is to be replaced, it is imperative to use the special tool (rolling tool) for assembly. Then fix the tube with cylindrical screw (2). (Oil cylindrical screw)
- ※ It is always necessary to use new cylindrical screws.

· Tightening torque (M8/8.8×12) :

2.34 kgf · m (17.0 lbf · ft)

Rolling tool 5870 600 003

Lubricant 5870 451 006

- ※ The spare parts service supplies the lubricating oil tube (1) only as a complete package with the housing front part.

- ※ Single parts delivery upon request only.

- ※ Assembly is only possible with the special tool.

Rolling tool 5870 600 005

Lubricant 5870 451 006

- (2) Mount O-rings 22×3 into the annular groove of the oil tubes (1 and 2) and oil them.

Then insert tubes into the housing front part, oil cylindrical screws (3 and 4) and fix them.

- ※ It is always necessary to use new cylindrical screws.

· Tightening torque (M8/8.8×12) :

2.34 kgf · m (17.0 lbf · ft)

· Tightening torque (M8/8.8×50) :

2.34 kgf · m (17.0 lbf · ft)

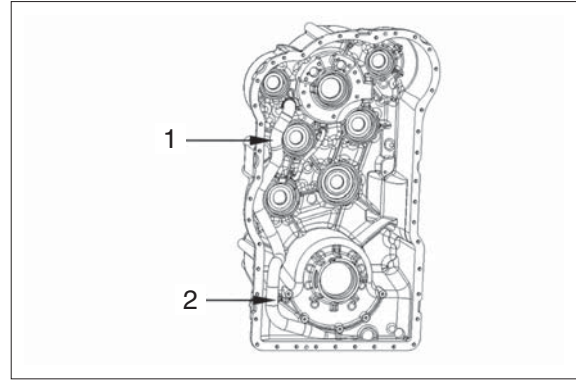

7609ATM306

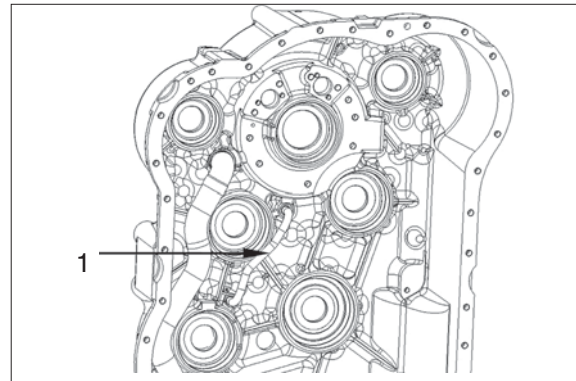

7609ATM307

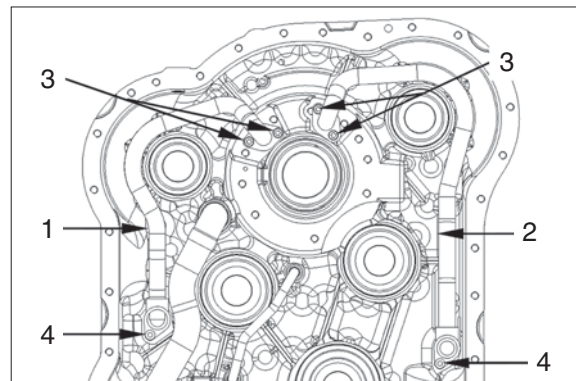

7609ATM308



- (3) Mount O-rings 22×3 into the annular groove of the oil tubes (1 and 2) and oil them.

Then insert tubes into the housing front part.

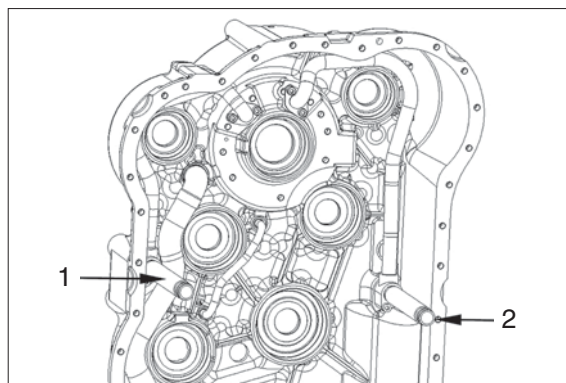

7609ATM309

- ※ The spare parts service supplies the lubricating oil tubes (1 and 2) only as a complete package with the housing rear part.
- ※ Single parts delivery upon request only.
- ※ Assembly is only possible with the special tool.

Rolling tool                      5870 600 006  
 Lubricant                         5870 451 006

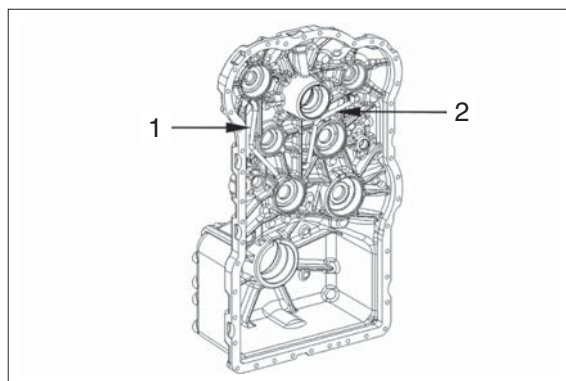

7609ATM310

- (4) Insert all bearing outer rings into the bearing holes of both housing parts.

Housing front part :

- AN Input
- AB Output
- KV Forward clutch
- KR Reverse clutch
- K1 1st gear clutch
- K2 2nd gear clutch
- K3 3rd gear clutch
- K4 4th gear clutch

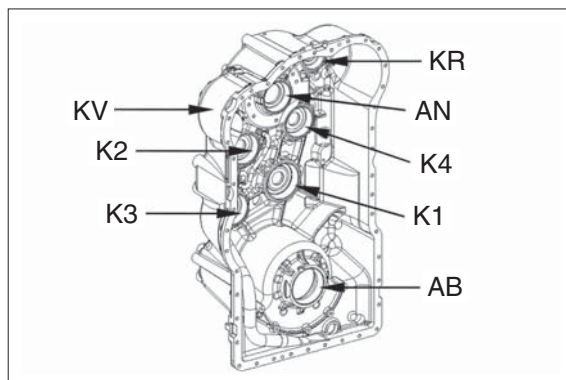

7609ATM311

- ※ Installation position see figure TM311 and TM312.

### Housing rear part :

(5) Legend see figure TM311.

- ※ Place bearing outer rings into the bearing holes using assembly grease.
- ※ If, contrary to the recommendation, the tapered roller bearings of clutches, input and output are not replaced, it is imperative to ensure the previous pairing (bearing inner ring/bearing outer ring).  
See figure TM054 and TM055.

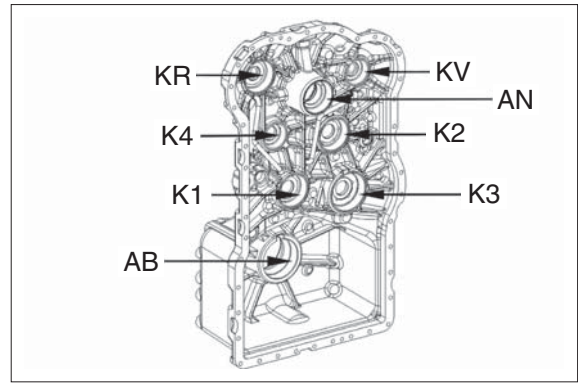

7609ATM312

- ※ Due to the installation conditions, the installation of single clutches without using the special tool is not possible.

#### ▲ Risk of injury.

(6) Install clutches by means of housing rear part (figure TM320 to TM321).

- ※ Housing rear part will be removed again later.

Place KR clutch, AN input shaft and KV clutch into the housing rear part at the same time.

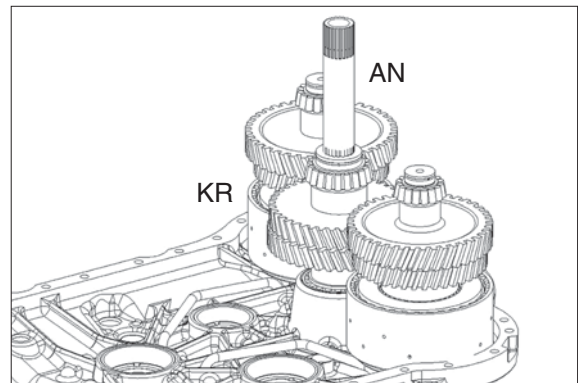

7609ATM313

(7) Slightly lift drive gear and position K4 clutch.

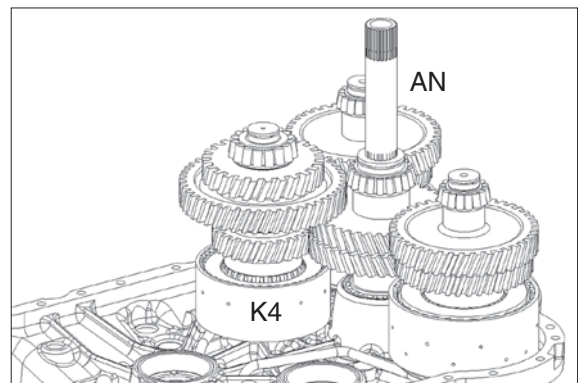

7609ATM314

(8) Mount K3 clutch.

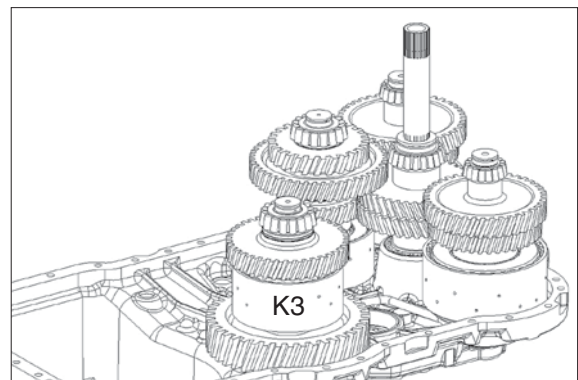

7609ATM315

(9) Position K2 clutch.

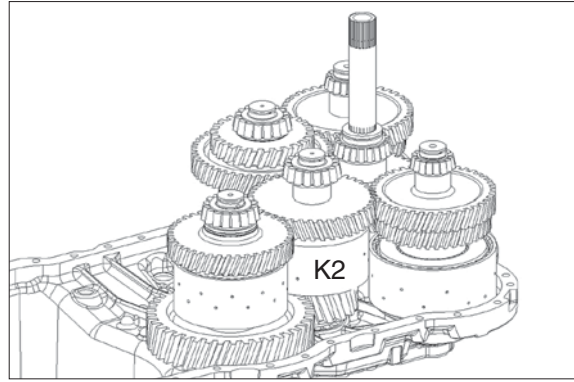

7609ATM316

(10) Slightly lift K4 clutch and position K1 clutch.

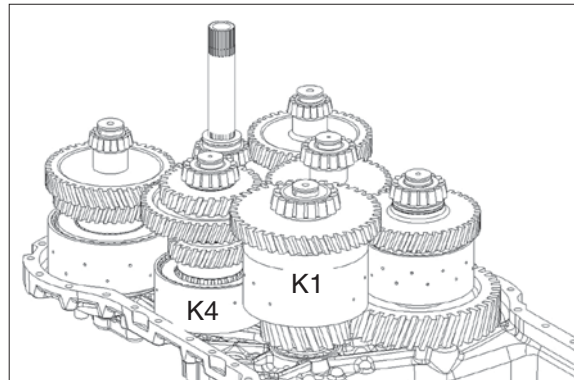

7609ATM317

(11) Press ball bearing 45×85×19 (1) onto the pump shaft (2) until contact is obtained.

Mount rectangular ring 60×3 (3).

Grease and centrally align rectangular ring.

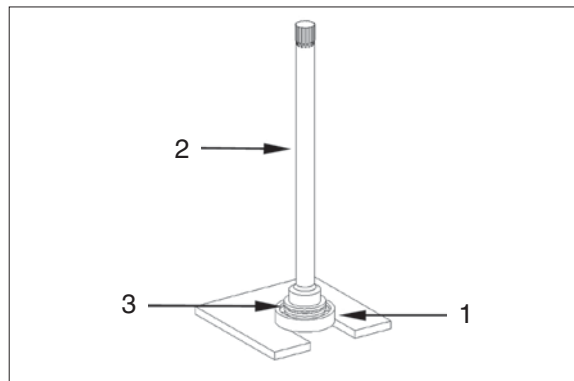

7609ATM318

(12) Mount pump shaft (1) until contact is obtained.

Fix pump shaft by means of retaining ring 85×3 (2).

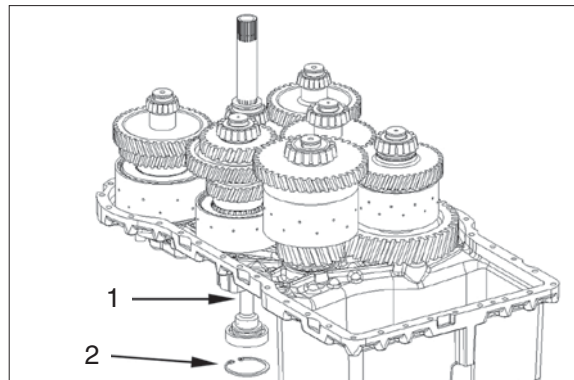

7609ATM319

※ The figure left shows the installation position of the individual clutches in the housing rear part one more time.

(13) Fix clutches K1, K2, K3 and K4 by using a handle.

Handle 5870 260 010

※ Clutches KV, KR and input shaft (2) are only fixed by the gear chain.

Check all rectangular rings, grease and align them centrally.

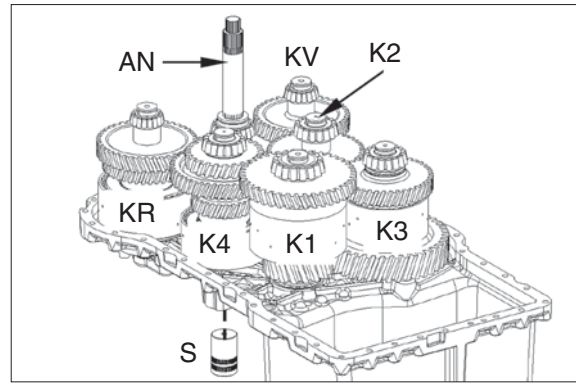

7609ATM320

(14) Pivot housing rear part 180° by using a lifting device.

- 1 Clutch KV
- 2 Input shaft
- 3 Clutch KR
- 4 Pump shaft

※ Clutch KV, KR and input shaft are only fixed by the gear chain.

Attention must be paid that the non-fixed components of the gear chain do not get loose.

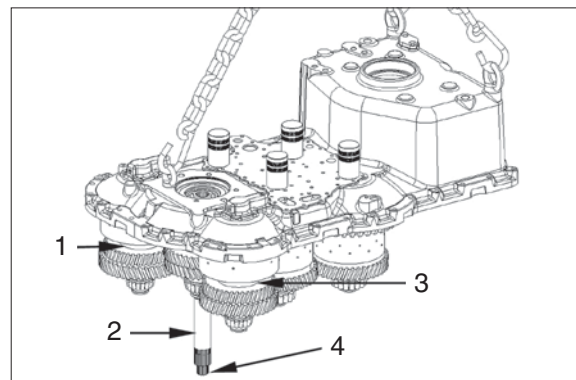

7609ATM321

(15) Use the lifting device to bring the housing rear part into contact position with the housing front part, by cautiously assembling the clutches.

Then remove handles.

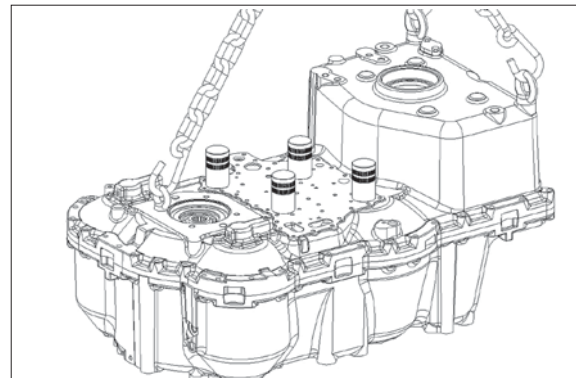

7609ATM322

(16) Remove housing rear part again.

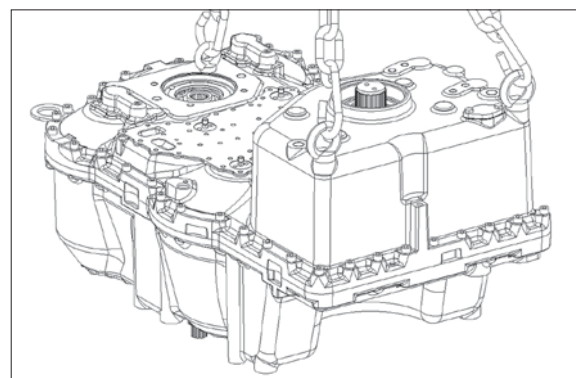

7609ATM323

(17) Put on screen sheet (1).

Install preassembled output shaft (2).

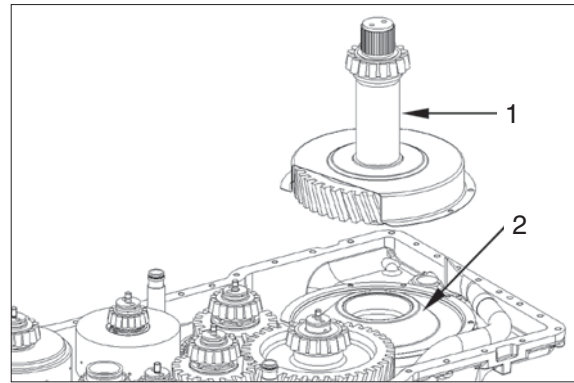

7609ATM324

(18) Oil cylindrical screws (1) and use them to fix screen sheet .

Tightening torque (M8/8.8×12) :

2.35 kgf · m (17.0 lbf · ft)

※ It is always necessary to use new cylindrical screws.

Mount O-rings 22×3 (2) into the annular groove of the oil tubes and oil them.

Mount all rectangular rings (4), grease and align them centrally.

Wet mounting face (3) with sealing agent loctite (type No. 574).

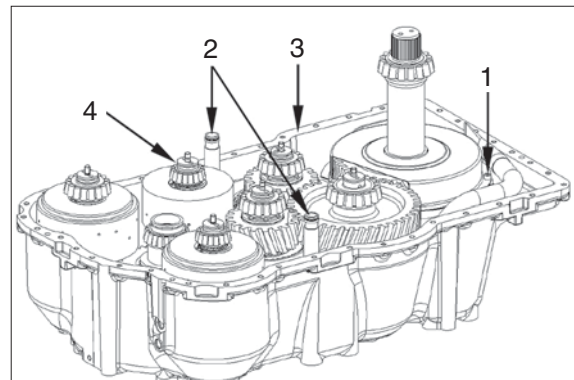

7609ATM325

(19) Carefully bring the housing front part into contact position with the housing rear part by using the lifting device.

※ Pay attention that both oil tubes are aligned with the holes in the housing rear part.

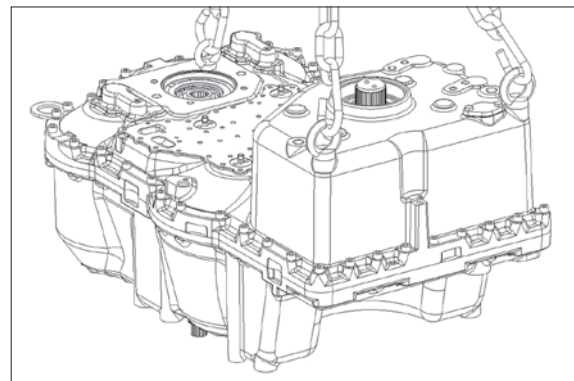

7609ATM326



(20) Fit both cylindrical pins 10×24 (1) centrally to the mounting face.

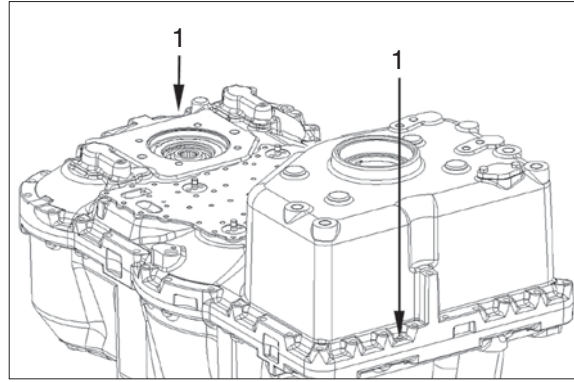

7609ATM327

### Checking of clearance of the gear drive train

(21) Position driving element and rotate KV clutch shaft.

※ If you notice an interference of the movable parts (e.g. on the screen sheet or on the oil tubes), you must correct this fault.

Do this step on all clutch shafts.

Driving element	5870 345 089
Crank handle	5870 280 007

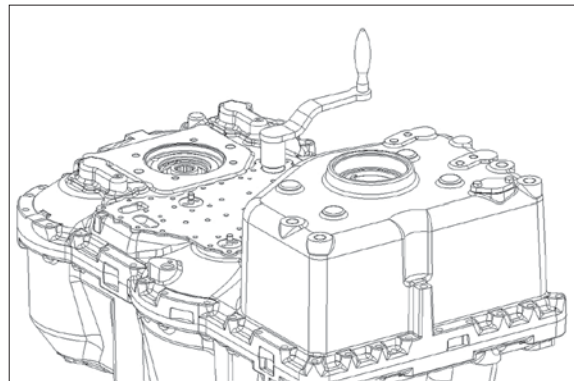

7609ATM328

(22) Fix housing front and rear part by means of cylindrical screws (1).

· Tightening torque (M10/8.8×50) :  
4.69 kgf · m (33.9 lbf · ft)

Mount fixing plate (2).

Mount stud bolts (3).

※ Wet screw-in thread with loctite (type No. 243).

· Tightening torque (M8/10.9×25) :  
1.53 kgf · m (11.1 lbf · ft)

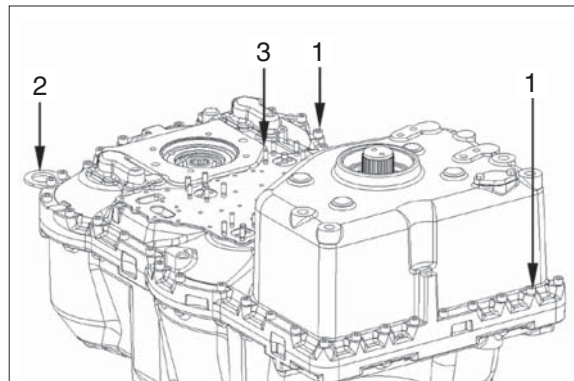

7609ATM329

(23) The screw plugs (1) must be mounted with a hydraulic pneumatic pressing tool.

※ In case of damage the premounted transmission housing rear part should/ must be fully replaced.

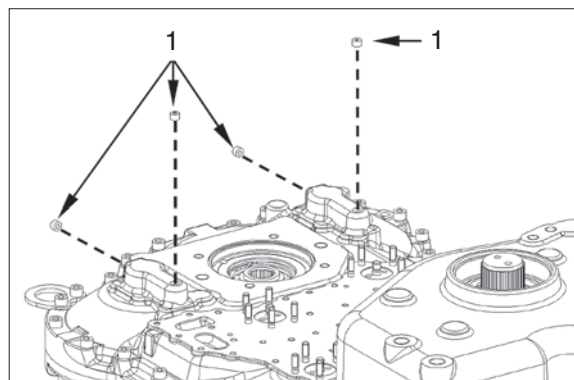

7609ATM330

## 10) ASSEMBLY

### Outputs flange

#### (1) Output flange on output side

- ① Use driver (S) to mount shaft seal  $90 \times 120 \times 13$ , with the sealing lip showing to the oil sump.

Driver 5870 048 237

- ※ Use of the specified driver (S) ensures the exact installation position.
- ※ Fill space between sealing lip and dust lip with grease.  
Wet outer diameter (rubber-coated) with spirit.

- ※ Installation position shaft seal see figure TM332.

- 1 Shaft seal  $90 \times 120 \times 13$
- 2 Gearbox housing - rear section
- 3 Roller bearing
- 4 Output shaft

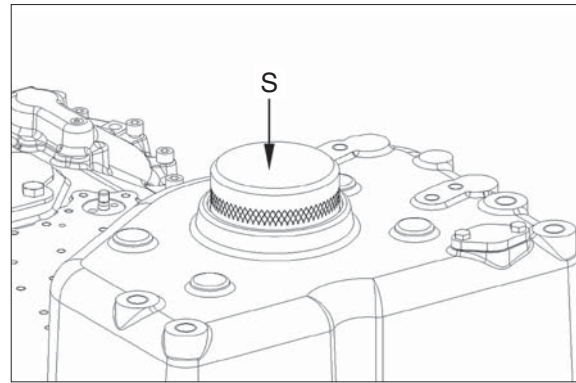

7609ATM331

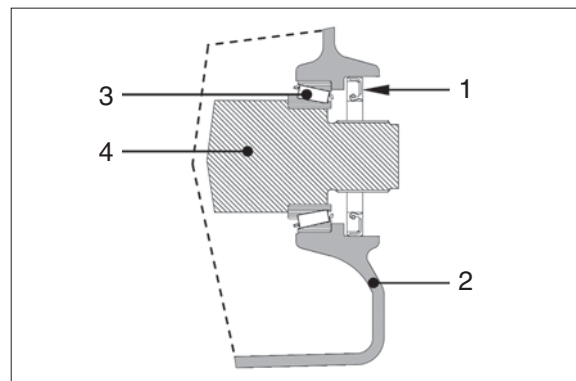

7609ATM332

- ② Press screen sheet (1) onto the input flange (2).

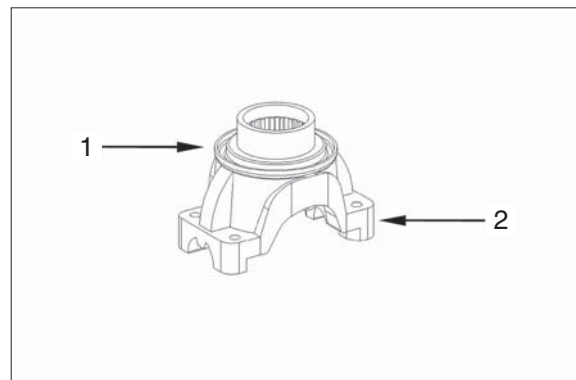

7609ATM333

- ③ Mount output flange (1) until contact is obtained.

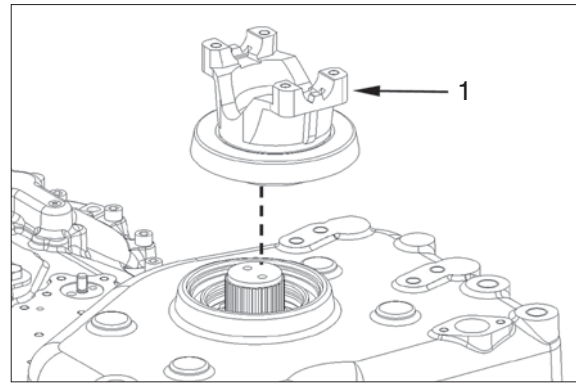

7609ATM334

- ④ Insert O-ring 48×4 into the space between output flange and shaft.

Fix output flange (1) by means of washer (2) and hexagon screws (3).

Oil hexagon screws before the assembly.

· Tightening torque (M10/8.×30) :  
4.69 kgf · m (33.9 lbf · ft)

- ※ It is always necessary to use new hexagon screws.

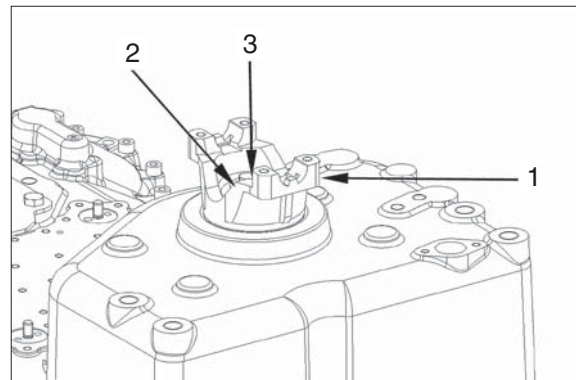

7609ATM335

## (2) Output flange output side with parking brake

- ① Use driver (S) to mount shaft seal 90×120×13, with the sealing lip showing to the oil sump.

Driver 5870 048 237

- ※ Use of the specified driver (S) ensures the exact installation position.
- ※ Fill space between sealing lip and dust lip with grease.
- ※ Wet outer diameter (rubber-coated) with spirit.
- ※ Installation position shaft seal see figure TM332.

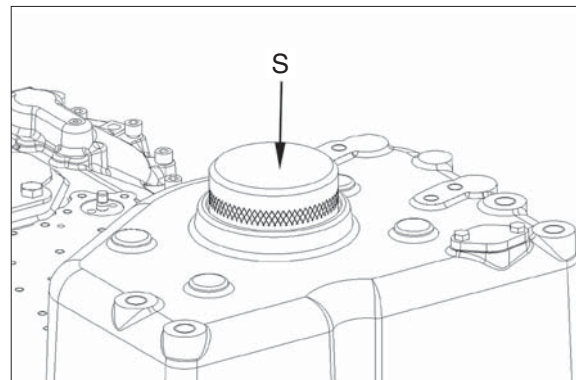

7609ATM336



- ② Press screen sheet (1) onto the input flange (2).

Mount output flange (2) until contact is obtained.

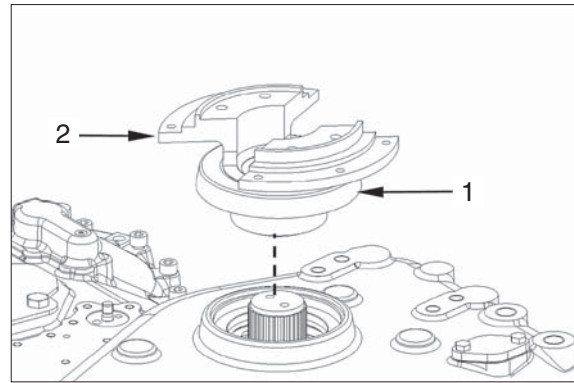

7609ATM337

- ③ Insert O-ring 48×4 into the space between output flange and shaft.

- ※ Fix output flange (1) by means of washer (2) and hexagon screws.

Oil hexagon screws before the assembly.

- Tightening torque (M10/10.9×30) :  
6.93 kgf · m (50.2 lbf · ft)

- ※ It is always necessary to use new hexagon screws.

Mount cylindrical screw with washer (3) for stop of the parking brake setting screw.

- Tightening torque (M10/8.8×16) :  
4.89 kgf · m (35.4 lbf · ft)

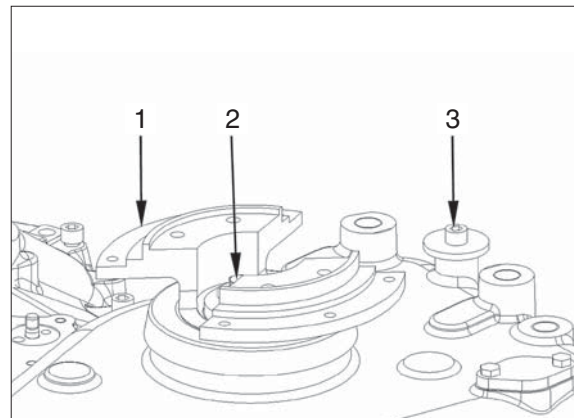

7609ATM338

- ④ Fix brake disk (1) at output flange by means of hexagon screws (2) and washers.

- Tightening torque (M10/10.9×25) :  
6.93 kgf · m (50.2 lbf · ft)

Connect HP pump on port (see arrow) and apply approx. 80 bar pressure to parking brake (3) and bring it in contact position.

HP hand-operated pump 5870 287 007  
MINIMESS coupling 5870 950 101

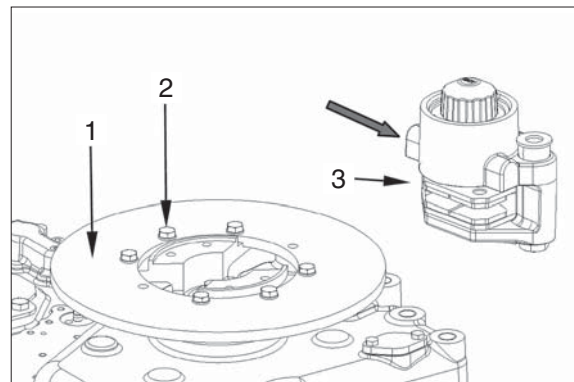

7609ATM339

- ⑤ Fix parking brake (1) on transmission housing using the hexagon screw - guide pin (2).

· Tightening torque (M20×1.5) :  
4.69 kgf · m (33.9 lbf · ft)

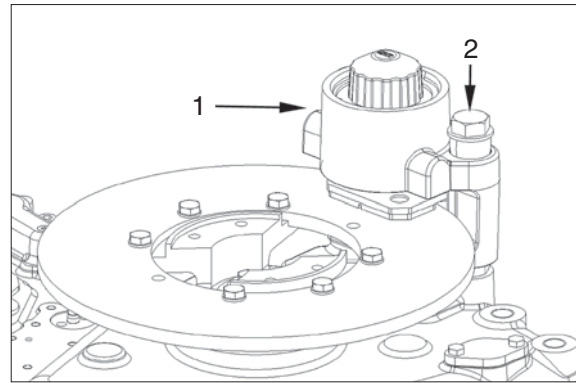

7609ATM340

- ⑥ Fix hexagon nut on brake caliper using the open end wrench insert.

· Tightening torque (M20×1.5) :  
23.5 kgf · m (170 lbf · ft)

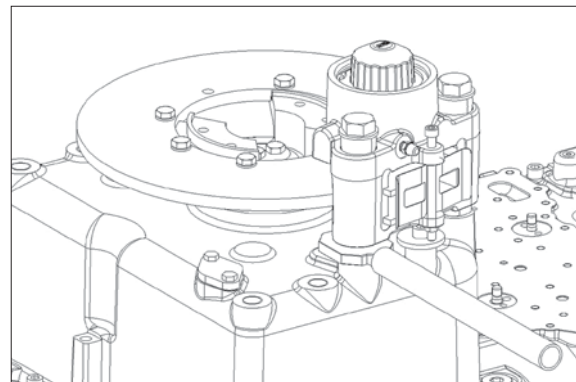

7609ATM341

- ⑦ Insert setting gauge on both sides between base disk and brake disk and hold in its position.

※ All installation, fitting and maintenance instructions, functional characteristics and setting specifications for the parking brake see page 4-22, "PARKING BRAKE SYSTEM".

Clearance : 0.5 - 1.5 mm  
Nom. clearance : 1.0 mm

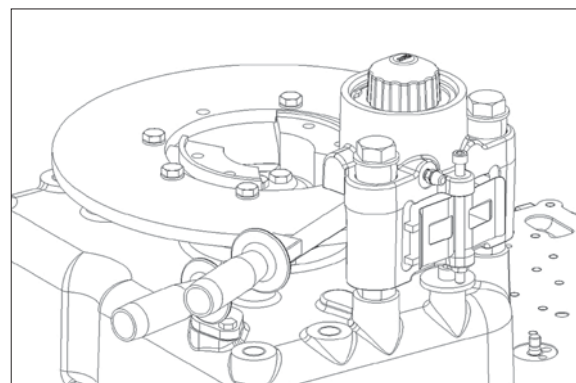

7609ATM342

### (3) Output flange on converter side

- ① Use driver (S) to mount shaft seal 90×120×13, with the sealing lip showing to the oil sump.

Driver 5870 048 237

- ※ Use of the specified driver (S) ensures the exact installation position.  
 ※ Fill space between sealing lip and dust lip with grease.  
 ※ Installation position shaft seal see figure TM344.

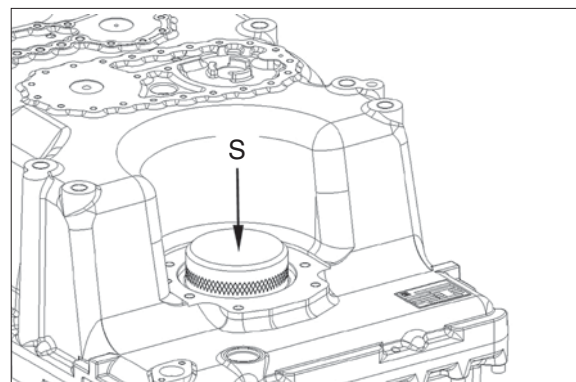

7609ATM343

- 1 Shaft seal  $90 \times 120 \times 13$
- 2 Gearbox housing - rear section
- 3 Roller bearing
- 4 Output shaft
- 5 Screen sheet

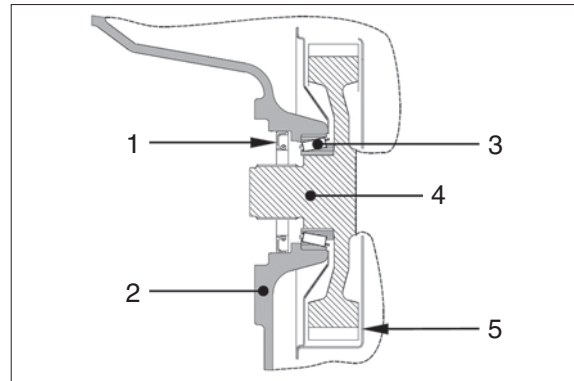

7609ATM344

- ② Press screen sheet (1) onto the input flange (2).
- Mount output flange (2) until contact is obtained.

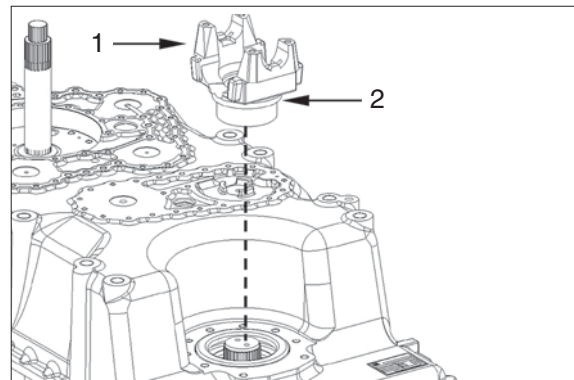

7609ATM345

- ③ Insert O-ring  $48 \times 4$  into the space between output flange and shaft.

Fix output flange (1) by means of washer (2) and hexagon screws (3).

Oil hexagon screws before the assembly.

- Tightening torque (M10/8.8  $\times$  30) :  
4.69 kgf · m (33.9 lbf · ft)

- ※ It is always necessary to use new hexagon screws.

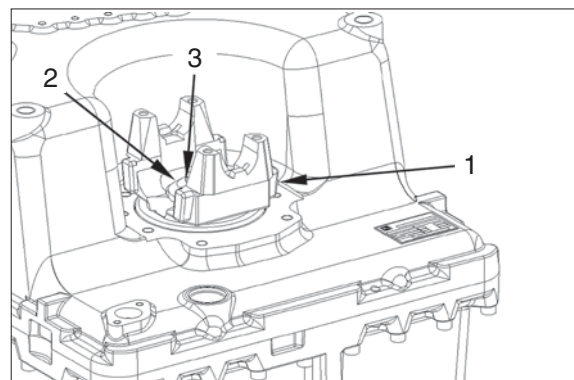

7609ATM346

## 11) REASSEMBLY

Engine connection, oil pressure pump, converter back-pressure valve and temperature sensor (measuring point "63" after the converter).

### (1) Converter back-pressure valve

① The figure shows the single parts of the converter back-pressure valve.

- 1 Oil feed housing
- 2 Piston
- 3 Compression spring
- 4 Pressure plate
- 5 Locking plate

※ Install pressure plate (4), with the pin ( $\varnothing 6$  mm) showing to the locking plate (5).

② Assemble single parts, preload them with assembly aid (S) and fix them by means of locking plate (1).

Assembly aid                      5870 345 107

③ Mount temperature sensor (1) with O-ring  $11 \times 2$ .

· Tightening torque :  
2.55 kgf · m (18.4 lbf · ft)

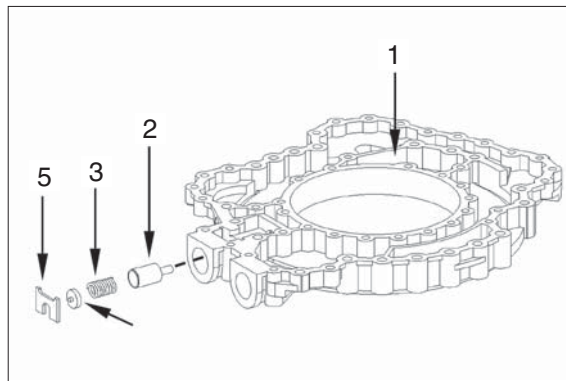

7609ATM347

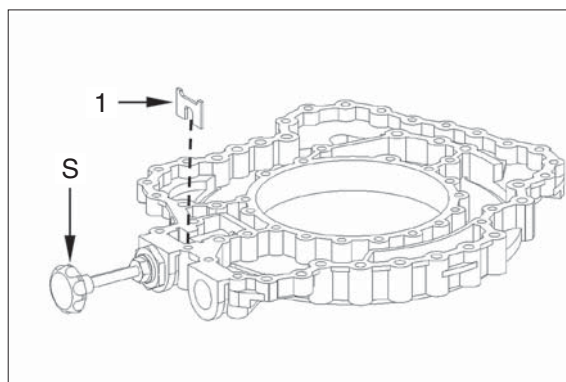

7609ATM348

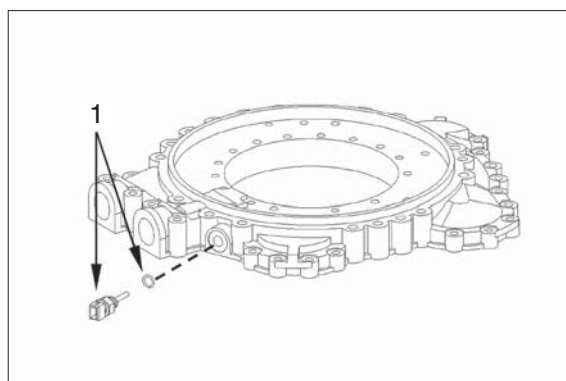

7609ATM349

## (2) Oil pressure pump

- ① Insert pressure relief valve (1) into the housing hole until contact is obtained.

Mount two adjusting screws (S) and place gasket (2) and oil feed housing (3).

- ※ Use assembly grease.

Adjusting screws (M8) 5870 204 011

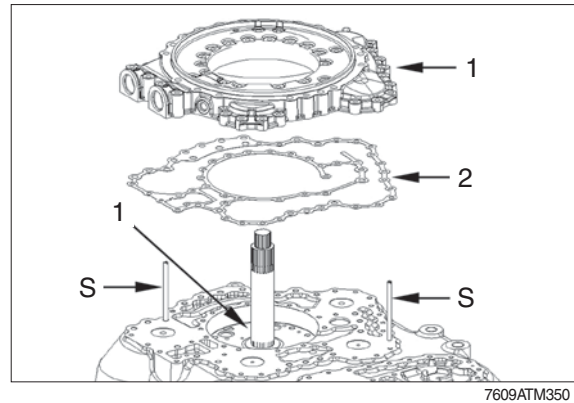

- ② Install two adjusting screws (S) and mount stator shaft (1).

- ※ Pay attention to radial installation position.

Adjusting screws (M10) 5870 204 007

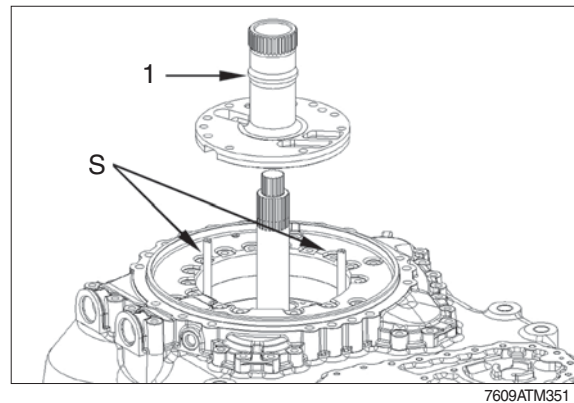

- ※ In case of wear marks in the pump housing or on the control disk, the pump assy must be replaced.

- ③ Install outer rotor.

- ※ Chamfer (see arrow) to show downwards.

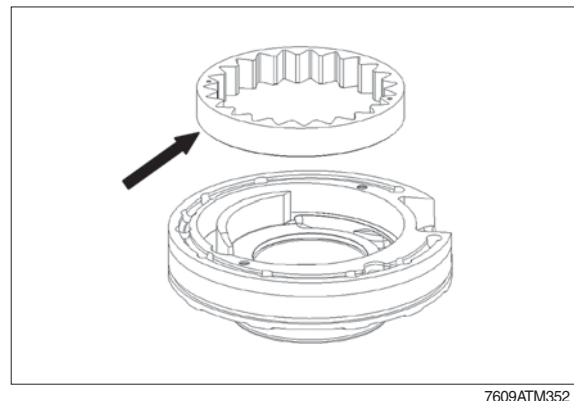

- ④ Install inner rotor.

- ※ Teeth (see arrow) to show upwards.

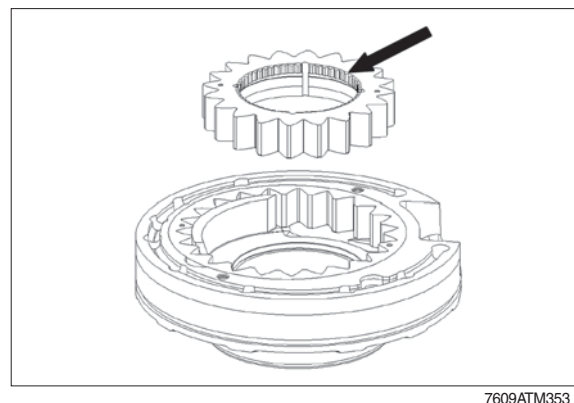

⑤ Place control disk and fix it radially by means of two cylindrical screws M6×12 (1).

※ Do not tighten the cylindrical screws - just turn them in until contact is obtained and then turn them back by approx. 1/2 rotation.

※ Pay attention to the installation position of the control disk, see figure.

Place O-ring 182×3 (2) into the annular groove and oil it.

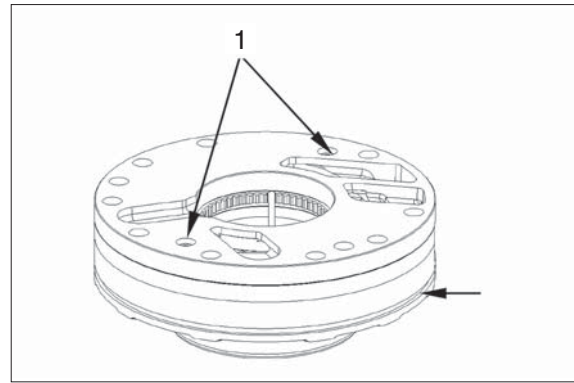

7609ATM354

⑥ With the sealing lip showing downwards, carefully insert the shaft seal 75×905×10 (1) into the pump housing (2) until contact is obtained.

※ Wet outer diameter of shaft seal with spirit.

Driver	5870 055 070
Handle	5870 260 002

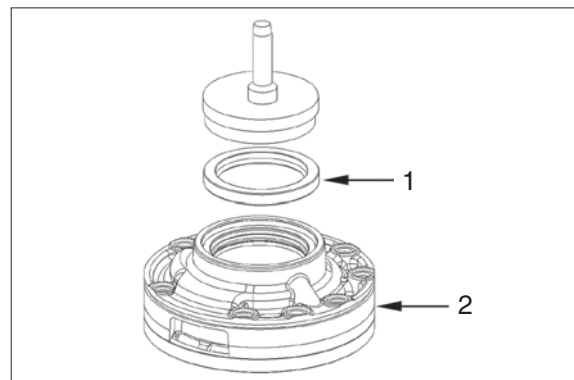

7609ATM355

※ Oil sliding bearing (see arrow) before the assembly.

⑦ Mount inner installer (S) onto the stator shaft.

Mount preassembled transmission pump (1).

※ Pay attention to radial installation position.

Inner installer see figure TM357

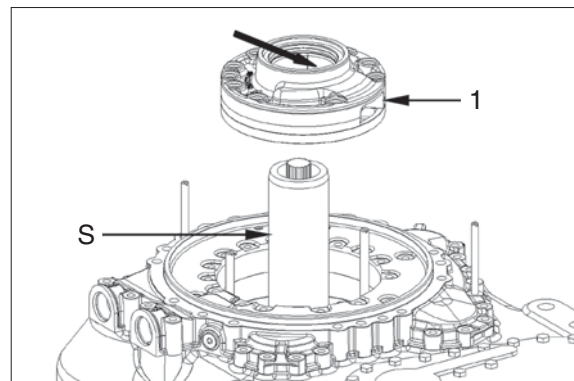

7609ATM356

⑧ Mount preassembled pump with driver (S1) until contact is obtained.

Assembly fixture (S + S1) 5870 345 126  
(Inner installer and driver)

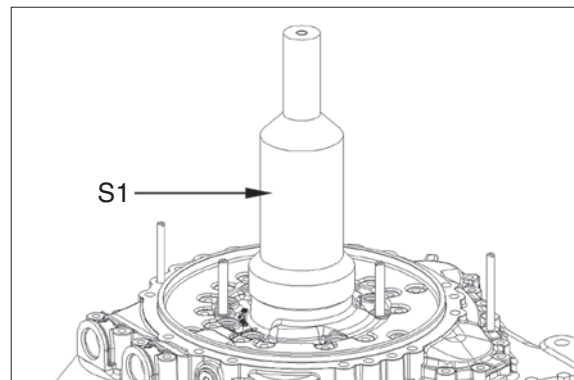

7609ATM357



- ⑨ Fit O-rings 9.5×1.6 to the cylindrical screws 10×75.

※ Grease O-rings.

Fix transmission pump (2) by means of cylindrical screws (1).

- Tightening torque (10/8.8×75) :  
4.69 kgf · m (33.9 lbf · ft)

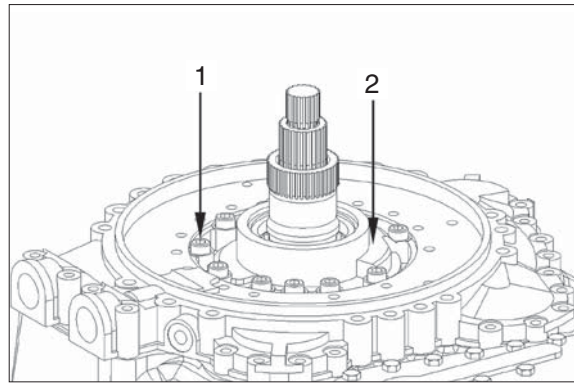

7609ATM358

- ⑩ Fix oil feed housing (1) equally by means of Torx screws (2).

- Tightening torque (M8/10.9×30) :  
2.35 kgf · m (17.0 lbf · ft)
- Tightening torque (M8/10.9×45) :  
2.35 kgf · m (17.0 lbf · ft)
- Tightening torque (M8/10.9×60) :  
2.35 kgf · m (17.0 lbf · ft)

Fasten fixing plate (3) by means of cylindrical screws (4).

- Tightening torque (M8/8.8×40) :  
3.47 kgf · m (25.1 lbf · ft)

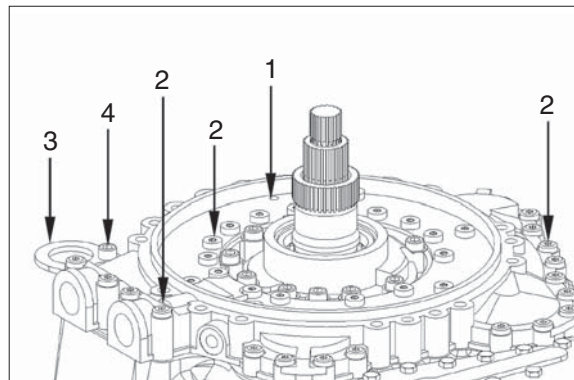

7609ATM359

- ⑪ Fix converter bell housing (1) by means of hexagon screws (2).

- Tightening torque (M10/10.9×65) :  
6.63 kgf · m (47.9 lbf · ft)

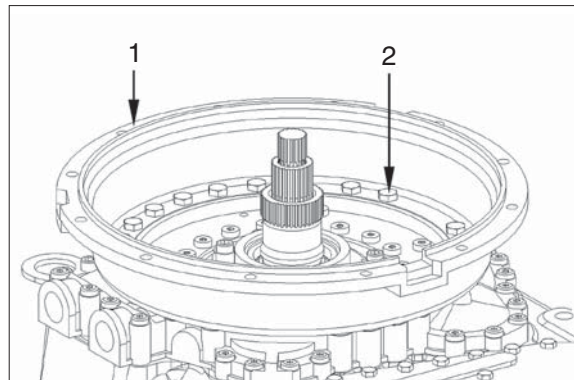

7609ATM360

### (3) Engine connection (direct mount)

- ① Position converter (1) by means of lifting device until contact is obtained.

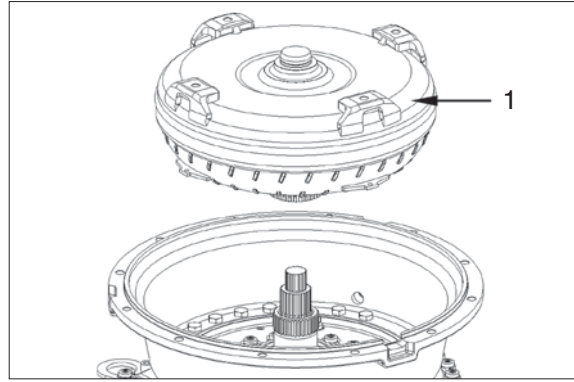

7609ATM361

- ② Position 1 washer/each / thickness = 1.0 mm (4EA) (1) onto the flex plate mounting webs (4EA).  
Place flex plates (2, 3 and 4).

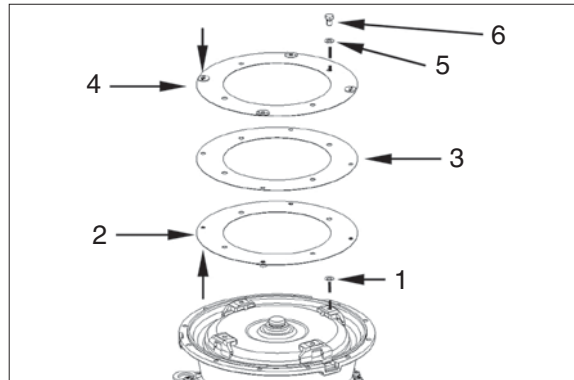

7609ATM362

- ※ Pay attention to the installation position.
  - Spot-welded reinforcing rings with thread of the flex plate (2) to be arranged towards the outside - see arrows.
  - Spot-welded reinforcing disks of the flex plate (3) to be arranged towards the outside - see arrows.

Mount washer (5) onto the hexagon screw M12×18 (6) and fix flex plate.

- ※ Wet threads of hexagon screws with loctite (type No. 262).

- ③ Fix flex plate (1) by means of hexagon screws (2).

- ※ Secure hexagon screws with loctite (type No. 262).

- Tightening torque (M12/10.9×18) :  
11.7 kgf · m (84.8 lbf · ft)

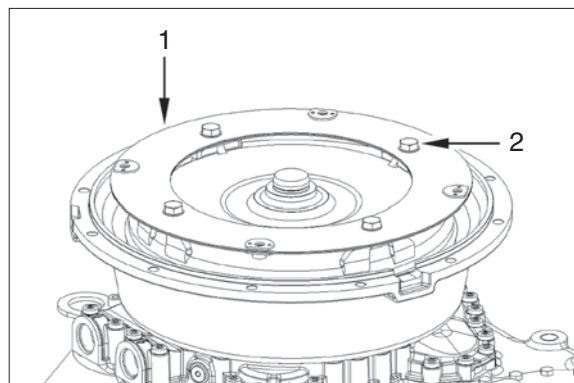

7609ATM363



## 12) REASSEMBLY - without emergency steering

- (1) Fit adjusting screws (S) and assemble seal (1) and cover (2).

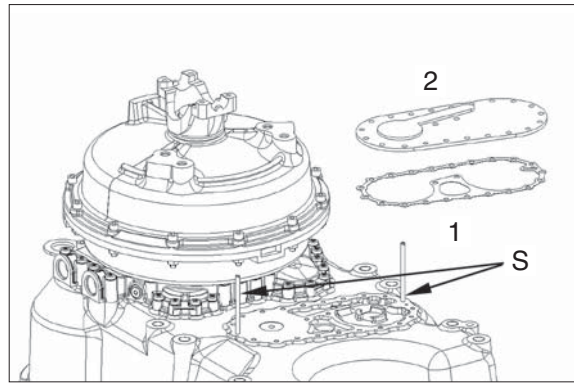

7609ATM364

- (2) Fix cover by means of hexagon screws (1).

- Tightening torque (M8/8.8×18) :  
2.35 kgf · m (17.0 lbf · ft)

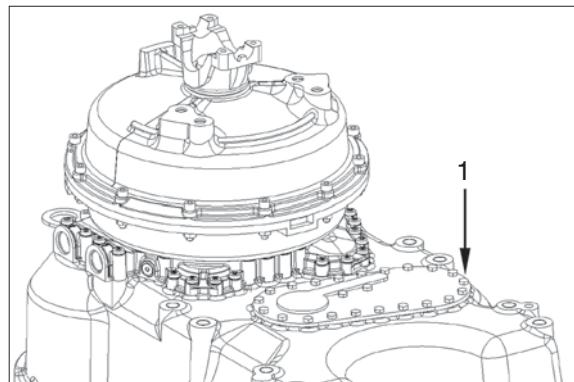

7609ATM365

### 13) REASSEMBLY

#### Inductive sensor, Hall sensor, breather, oil filler and oil drain plug

- (1) Mount inductive sensors (1, 2 and 3) with O-rings 15×2.

- 1 Inductive sensor - turbine speed
- 2 Inductive sensor - speed/central gear chain
- 3 Inductive sensor - engine speed

· Tightening torque :  
3.06 kgf · m (22.1 lbf · ft)

Mount breather (4).

· Tightening torque :  
1.22 kgf · m (8.85 lbf · ft)

Mount speed sensor (5) with O-ring 15.54 ×2.62 and fix it by means of cylindrical screw (6).

- 1 speed sensor (hall sensor) -  
output speed

· Tightening torque (M8/8.8×16) :  
2.35 kgf · m (17.0 lbf · ft)

Mount screw plug M26×1.5 (7) with O-ring 23×2.

· Tightening torque (M8/8.8×16) :  
8.16 kgf · m (59.0 lbf · ft)

Bring cover (8) with seal into contact position with the housing front part and fix it by means of hexagon screws (9).

· Tightening torque (M8/8.8×18) :  
2.35 kgf · m (17.0 lbf · ft)

- (2) Mount oil drain plug with O-ring 35×2 (1).

· Tightening torque (M38×1.5) :  
8.16 kgf · m (59.0 lbf · ft)

Bring oil level tube (2) with seal into contact position with the housing front part and fix it by means of hexagon screws (3).

· Tightening torque (M8/8.8×50) :  
3.47 kgf · m (25.1 lbf · ft)

Fasten dipstick (4) in oil level tube.

Fix identification plate (5) to the housing front part.

※ Use loctite (type No. MS 9360).

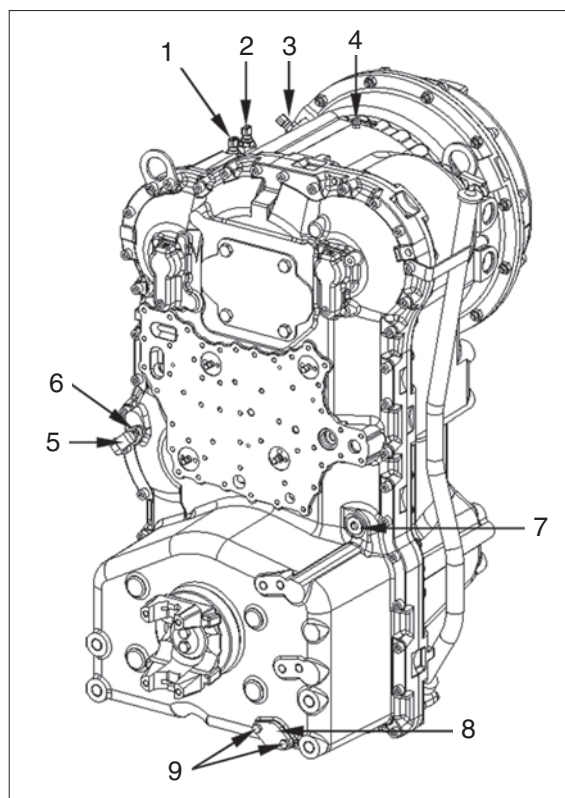

7609ATM366

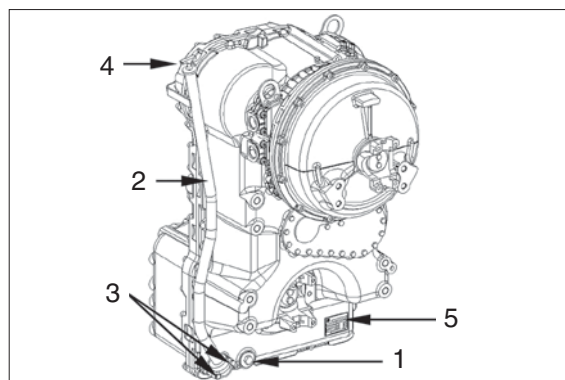

7609ATM367

## 14) REASSEMBLY

### Electro-hydraulic control with proportional valves :

※ The following sketches show the sectional views of the electro-hydraulic control.

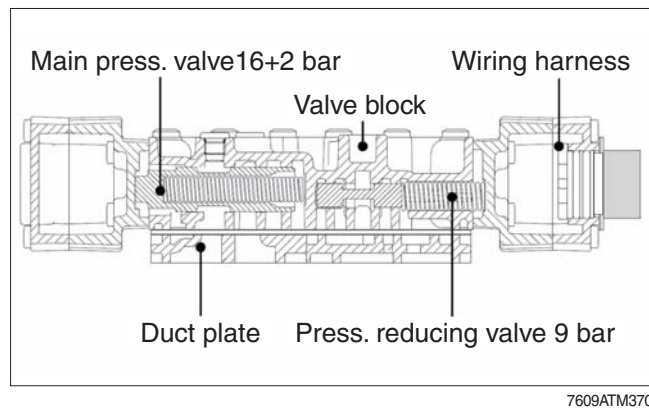
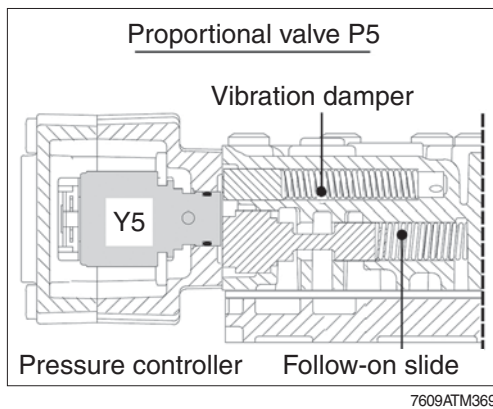
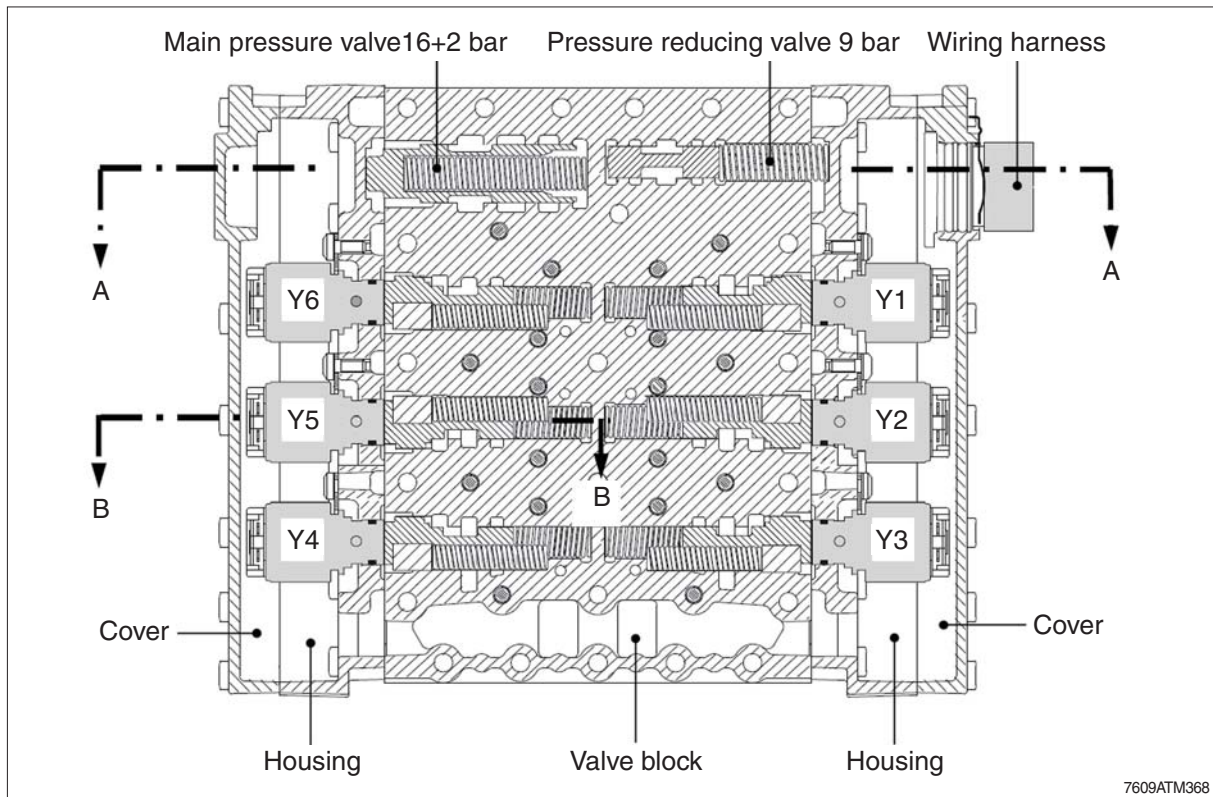

**(1) Fitting of electric control**

- ※ All single parts are to be checked for damage and replaced, if required. Ensure free travel of the moving parts in the valve block prior to installation. Pistons can be exchanged individually. Prior to the installation, oil single parts.

① With the concave side showing upwards, insert orifice (1) until contact is obtained.

- ※ See arrows for installation position.

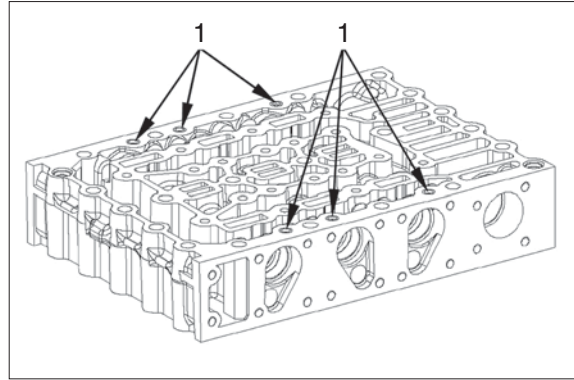

7609ATM371

② The opposite figure shows the following single parts :

- 1 Pressure reducing valve (1EA, piston and compr. spring)
- 2 Vibration damper (3EA, piston and compr. spring)
- 3 Follow-on slide (3EA, piston and compr. spring)

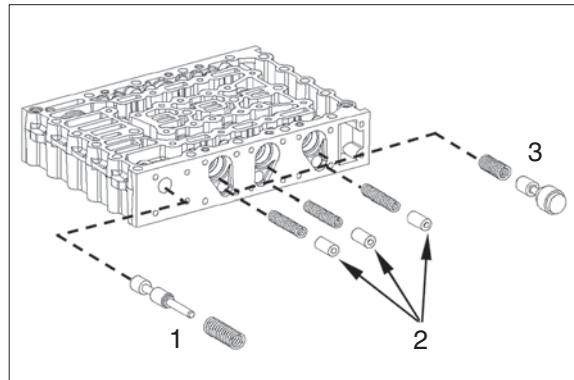

7609ATM372

③ Install the single parts according to figure TM372.

- ※ Preload compression springs of the follow-on slides and preliminarily fix pistons by means of cylindrical pins Ø5.0 mm (assembly aid), see arrows (S).

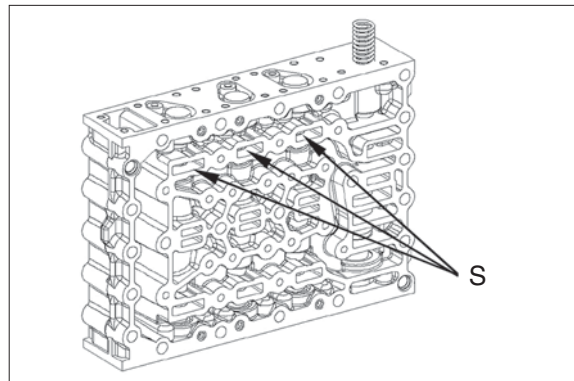

7609ATM373

④ Fit two adjusting screws.

- Mount seal (1) and housing (2).
- Then position housing equally by means of adjusting screws until contact is obtained.

Adjusting screws                      5870 204 036

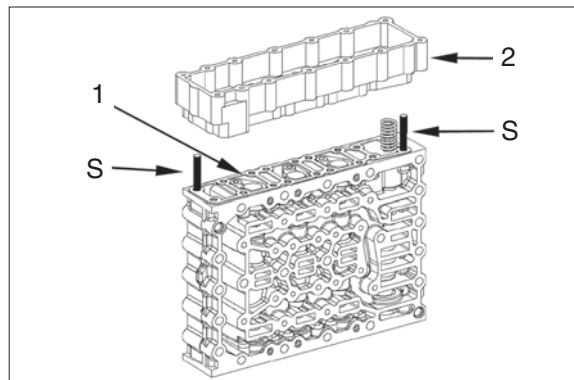

7609ATM374

- ⑤ Bring housing (1) into contact position by means of the Torx screws. This will preload the pistons, and you can remove the cylindrical pins (assembly aid).

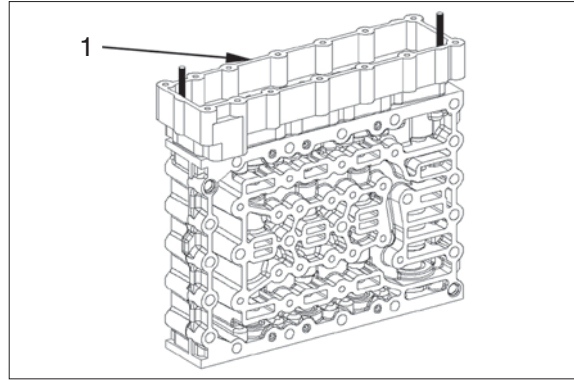

7609ATM375

- ⑥ Fix housing by means of Torx screws (1).

· Tightening torque (M5/10.9 × 30) :  
0.56 kgf · m (4.06 lbf · ft)

Reducing adapter            5870 656 056  
Socket wrench TX-27        5873 042 002

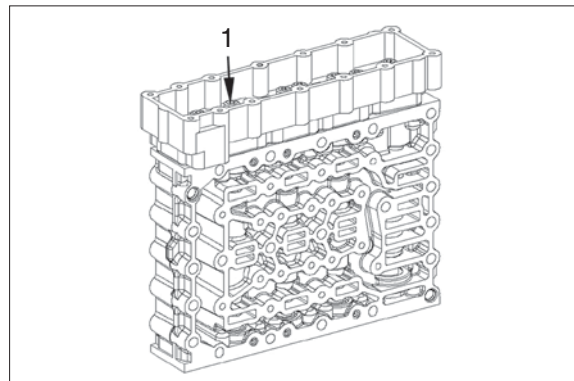

7609ATM376

- ⑦ Mount pressure controllers with O-ring 13.5 × 2 (1) and fasten them by means of fixing plates (2) and Torx screws (3).

※ Install fixing plate, with the claw showing downwards.

Pay attention to the radial installation position of pressure controllers, see figure.

· Tightening torque (M5/8.8 × 12) :  
0.56 kgf · m (4.06 lbf · ft)

Reducing adapter            5870 656 056  
Socket wrench TX-27        5873 042 002

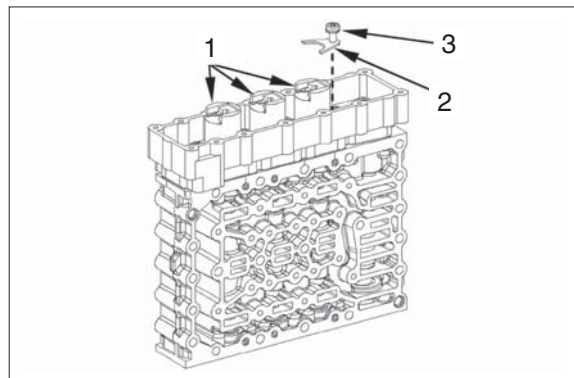

7609ATM377

### Preassemble the opposite side

- ⑧ The figure on the right shows the following single parts :

- 1 Main pressure valve  
(1EA, Piston a. compr.spring)  
2 Vibration damper  
(3EA, Piston a. compr.spring)  
3 Follow-on slide  
(3EA, Piston a. compr.spring)

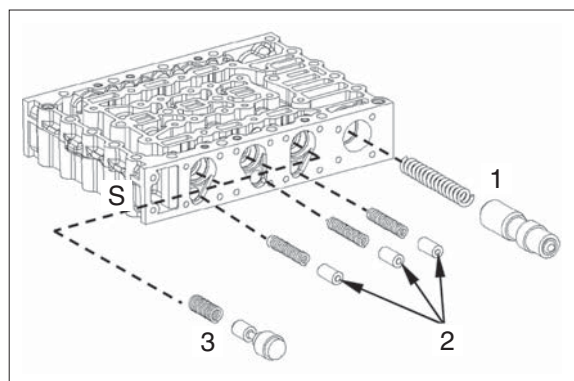

7609ATM378



⑨ Install the single parts according to figure TM378.

※ Preload the compression springs of the follow-on slides and fasten the pistons preliminarily by means of cylindrical pins (S)  $\varnothing 5.0$  mm (assembly aid), see arrows (S).

Install two adjusting screws.

Adjusting screws M5      5870 204 036

Assemble flat gasket (1) and housing cover. Then place the housing cover by means of adjusting screws equally until contact.

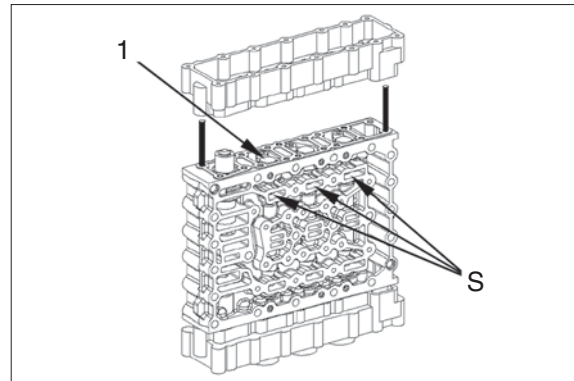

7609ATM379

⑩ Preload the pistons with Torx screws and remove the cyl. pins (assembly aid) again.

Then fasten the housing cover by means of Torx screws (1).

· Tightening torque (M5/10.9  $\times$  30) :  
0.56 kgf  $\cdot$  m (4.06 lbf  $\cdot$  ft)

Adjusting screws      5870 204 036  
Reducer                5870 656 056  
Socket spanner TX-27    5873 042 002

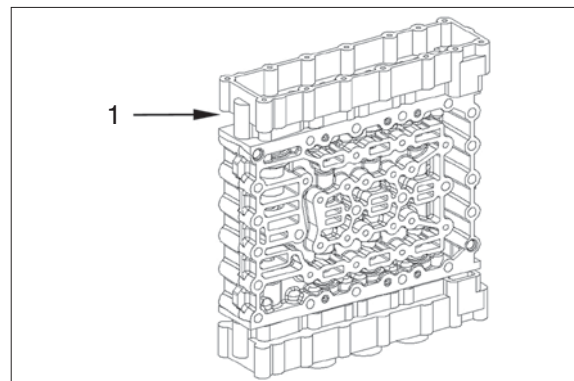

7609ATM380

⑪ Mount the pressure regulators with O-ring 13.5  $\times$  2 (1) and fasten them by means of fixing plates and cap screws.

※ Install the fixing plate with the neck showing downwards.

Observe radial installation position of the pressure regulators, see figure.

· Tightening torque (M5/8.8  $\times$  12) :  
0.56 kgf  $\cdot$  m (4.06 lbf  $\cdot$  ft)

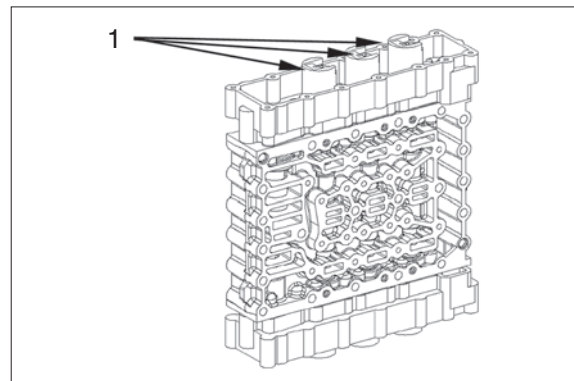

7609ATM381

⑫ Assemble the wiring harness (1) and connect the pressure regulators (6EA).

※ See figure TM368 for installation position of pressure regulators.

※ Pay attention to the installation position of the wiring harness, also see markings (figure TM009).

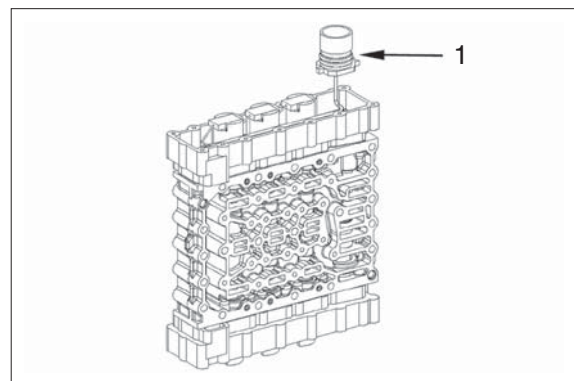

7609ATM382

⑬ Put on the flat gasket (1).

Assemble the plug socket with the slot showing to the lug of the cover until contact.

Fasten the cover by means of cap screws.

- Tightening torque (M5/10.9×30) :  
0.56 kgf · m (4.06 lbf · ft)

Reducer 5870 656 056  
Socket spanner TX-27 5873 042 002

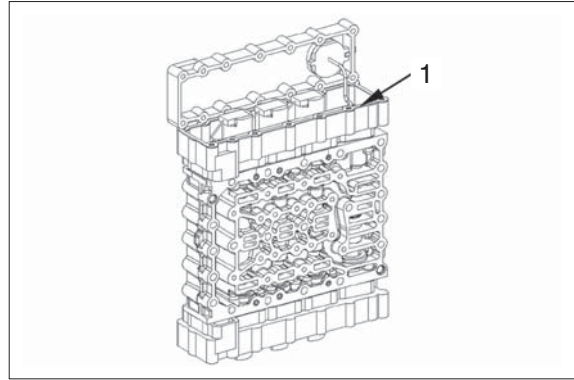

7609ATM383

⑭ Fix the wiring harness by means of retaining clamp (1).

- ※ Install the opposite cover.
- ※ Lock-up clutch solenoid valve, see figure TM396~TM397 (5-speed T/M).

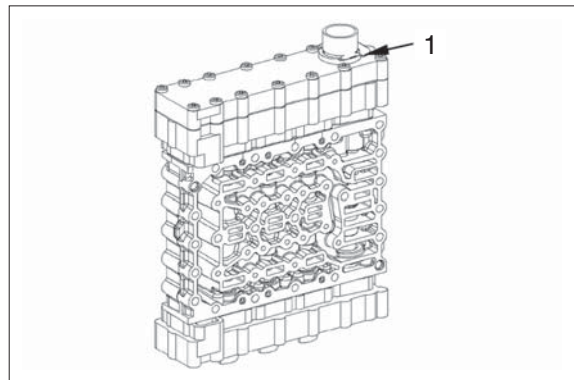

7609ATM384

⑮ Install two adjusting screws.

Adjusting screws 5870 204 063

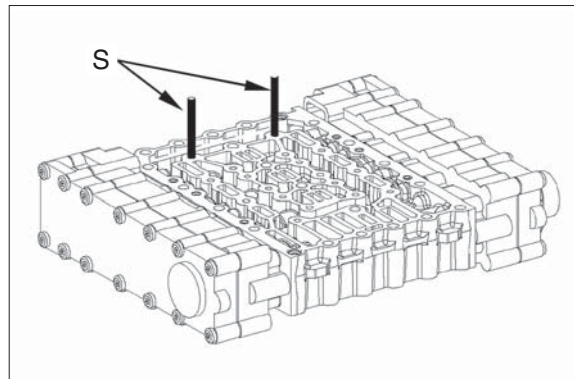

7609ATM385

⑯ Flush-mount screens (1) into the holes of the sealing plate, see arrows.

- ※ Pay attention to the installation position - screens to show upwards (towards the duct plate).

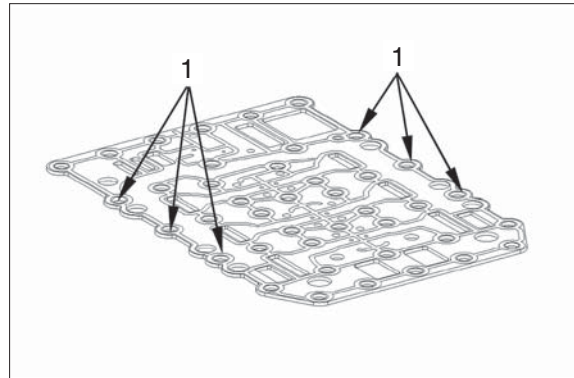

7609ATM386

⑰ Put on sealing plate (1) and duct plate (2).

※ Screens (3) to show upwards.

※ It is not permitted to reassemble the seal plate after opening the threaded joint shift unit/duct plate.

In case of repair it is always necessary to mount a new seal plate.

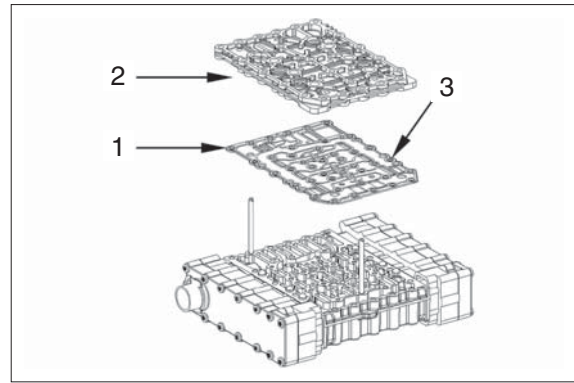

7609ATM387

⑱ Place duct plate (1) and fix it equally by means of Torx screws (2).

· Tightening torque (M6/10.9×23) :  
1.07 kgf · m (7.74 lbf · ft)

Socket wrench TX-27      5873 042 002

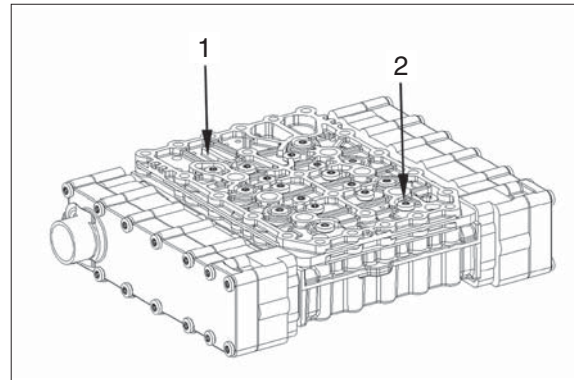

7609ATM388

⑲ Provide the screw plugs M10×1 with O-rings 8×1.5 (1) and install them.

· Tightening torque :  
0.61 kgf · m (4.43 lbf · ft)

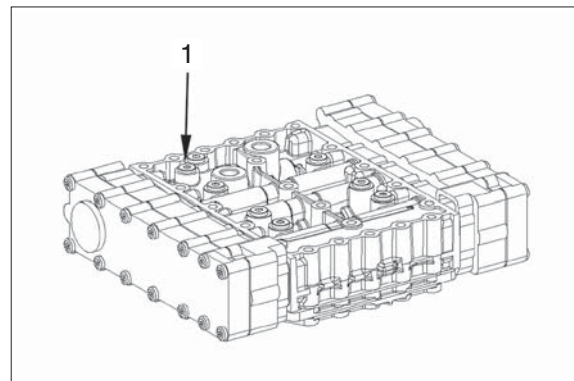

7609ATM389

⑳ Insert converter safety valve (1) into the housing hole until contact is obtained.

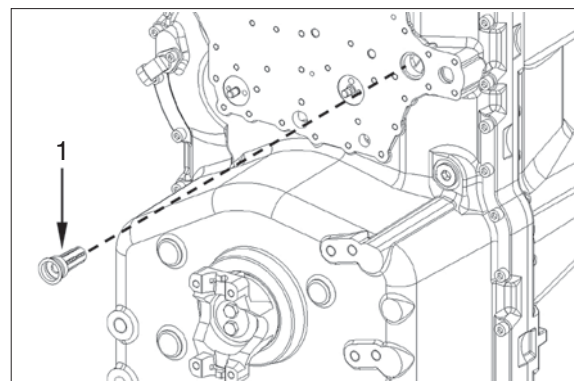

7609ATM390



㉑ Mount stud bolts (1).

※ Wet screw-in thread with loctite (type No. 243).

· Tightening torque (M8/10.9×25) :  
1.53 kgf · m (11.1 lbf · ft)

Place seal (2) and duct plate (3) at the housing rear part until contact is obtained.

※ Use assembly grease.

㉒ Fix duct plate (1) by means of Torx screws (2) and hexagon nuts (3).

· Tightening torque (M8/10.9×30) :  
2.35 kgf · m (17.0 lbf · ft)

· Tightening torque (M8) :  
2.35 kgf · m (17.0 lbf · ft)

Mount screw plug (4) with new O-ring 13 × 2.

· Tightening torque (M16×1.5) :  
3.06 kgf · m (22.1 lbf · ft)

Socket wrench TX-40 5873 042 004

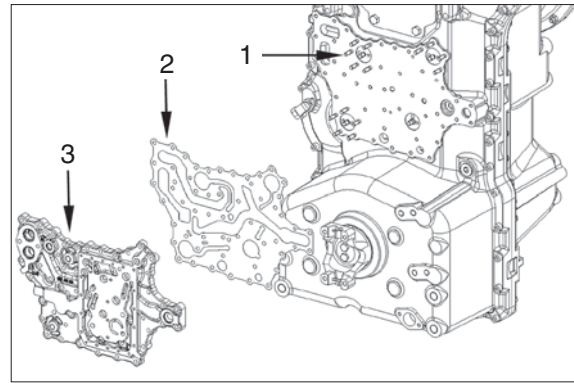

7609ATM391

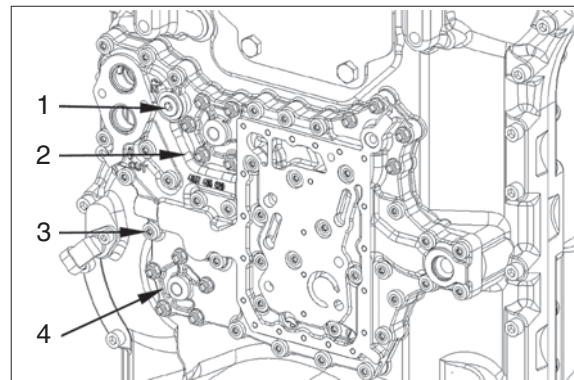

7609ATM392

㉓ Mount compression spring (4), piston (3) and switch (2) with new O-ring 13 × 2.

- 1 Filter differential pressure valve
- 2 Switch with O-ring
- 3 Piston
- 4 Compression spring

· Tightening torque :  
3.06 kgf · m (22.1 lbf · ft)

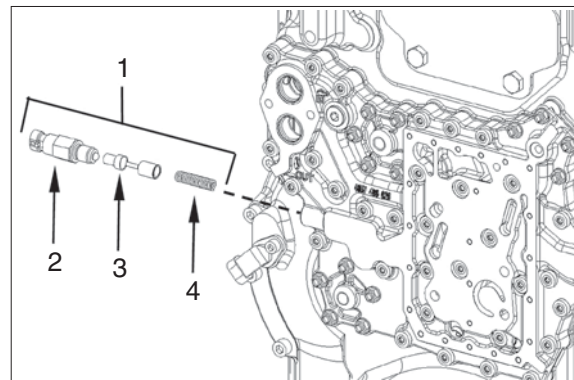

7609ATM393

㉔ Fit two adjusting screws.

Adjusting screws 5870 204 063

Mount sealing plate (1) and electro-hydraulic control unit (2).

※ It is not permitted to reassemble the seal plate after opening the threaded joint shift unit/gearbox housing.  
In case of repair it is always necessary to mount a new seal plate.

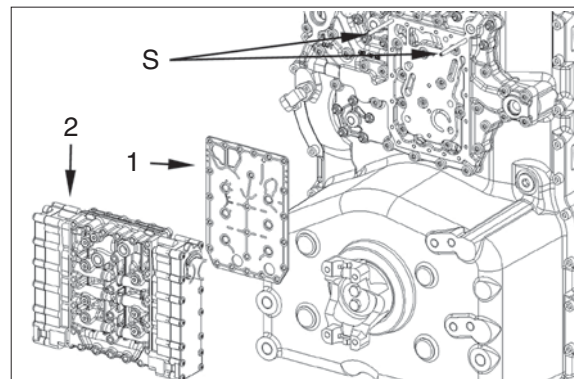

7609ATM394

② Fix electro-hydraulic control unit (1)  
equally by means of Torx screws (2).

· Tightening torque (M6/10.9×76) :  
3.06 kgf · m (22.1 lbf · ft)

Socket wrench TX-27      5873 042 002

Reducing adapter        5870 656 056

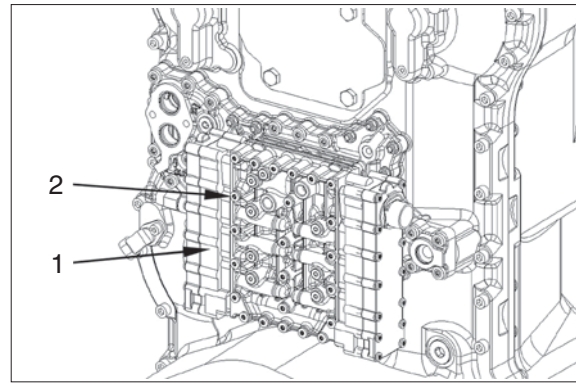

7609ATM395

### (3) Fitting of fine filter (pressure filter)

- ① Fix filter head (1) with new O-rings  $34.2 \times 3$  to the housing rear part by means of Torx screws (2).

· Tightening torque (M8/10.9  $\times$  60) :  
3.47 kgf · m (25.1 lbf · ft)

Socket wrench TX-40      5870 042 004

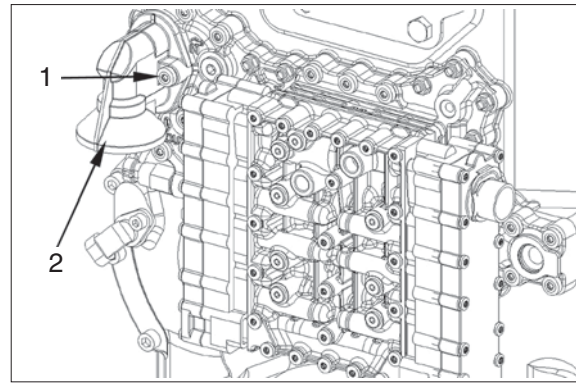

7609ATM400

- ※ The opposite figure shows the following single parts :
  - Slightly oil the seal
  - Turn in the filter until contact with the sealing surface is obtained, and then tighten it by hand with approx. 1/3 to 1/2 rotation.
- ※ Before putting the transmission into operation, fill it with oil according to operation manual.

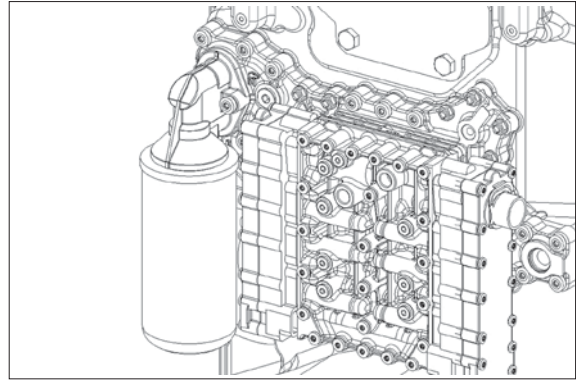

7609ATM401

## 2. AXLE (FRONT AND REAR)

### 1) DISASSEMBLY

#### (1) Disassembly output and brake

- ① Fix axle to assembly truck.

Assembly truck	5870 350 000
Fixtures	5870 350 077
Clamping brackets	5870 350 075
Support	5870 350 125

- ※ Before clamping the axle fully turn in the support. Position axle first onto the two fixtures, secure with clamping brackets and then unbolt the support until contact with the axle is obtained.

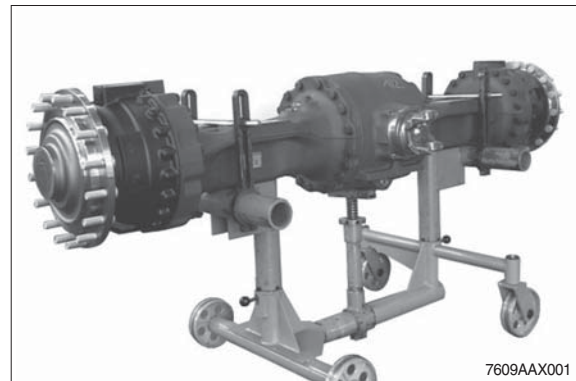

- ② Loosen screw plugs (3EA, see AX002 and AX003) and drain oil from the axle.

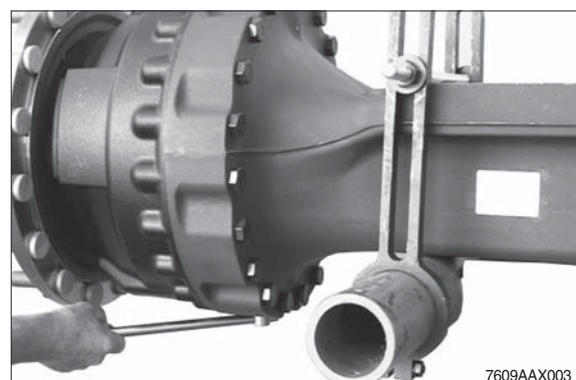
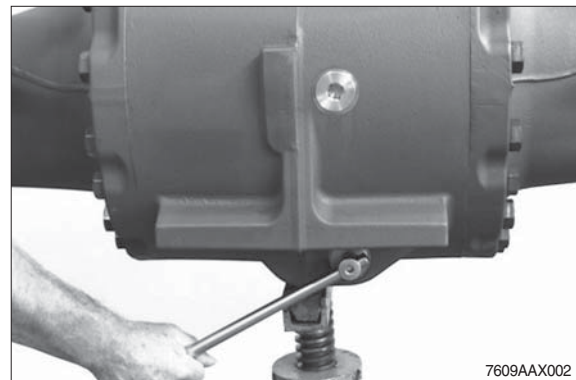

③ Remove the breather valve (see arrow).

※ To avoid any damage, the breather valve must be removed when separating the output.

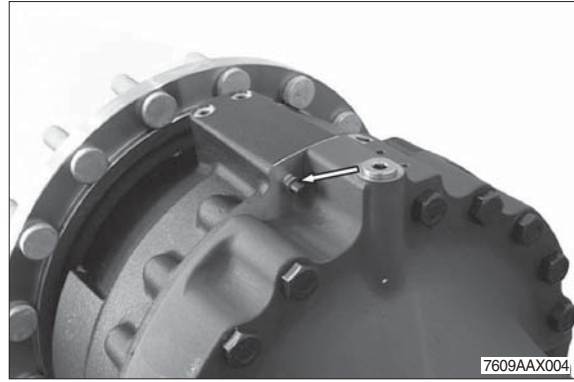

④ Secure the output with the lifting device and loosen hexagon screws.

Then separate the output assy from the axle housing.

Load carrying device      5870 281 043

※ Fix the load carrying device with a wheel nut.

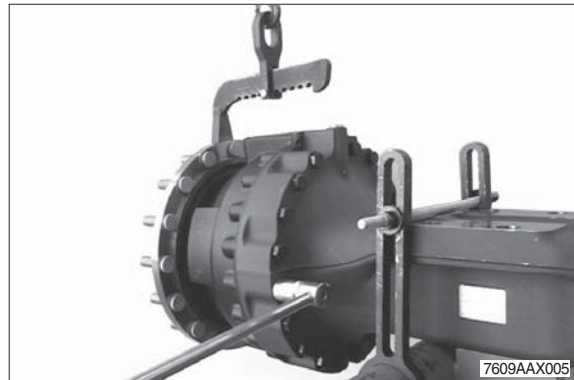

⑤ Pull stub shaft and sun gear shaft.

※ Pay attention to potentially releasing shim.

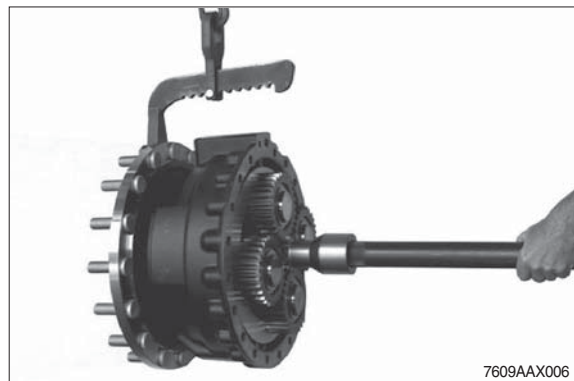

⑥ Fix output to assembly truck.

Assembly truck      5870 350 000

Fixture      5870 350 113

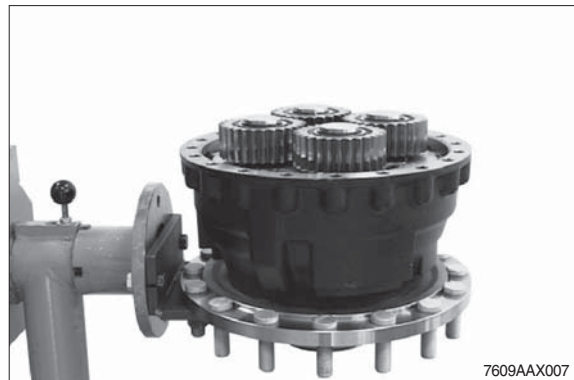



- ⑦ Use a lever to remove the cover from the output shaft.

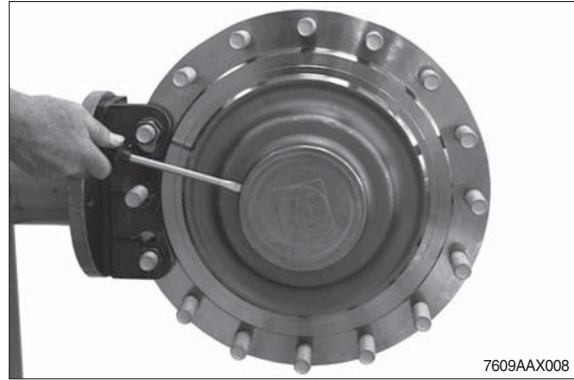

- ⑧ Loosen locking screws and remove the releasing cover.

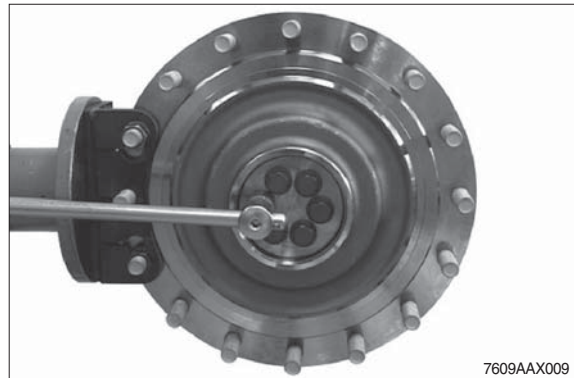

- ⑨ Press planetary carrier with a two-armed puller out of the profile of the output shaft.



- ⑩ Lift the planetary carrier out of the brake housing by means of the lifting device.

Rear axle

(planetary carrier with 3 planetary gears)

Inner extractor 5870 300 019

Eye bolt 5870 204 073

Front axle

(planetary carrier with 4 planetary gears)

Inner extractor 5870 300 017

Eye nut 5870 204 076

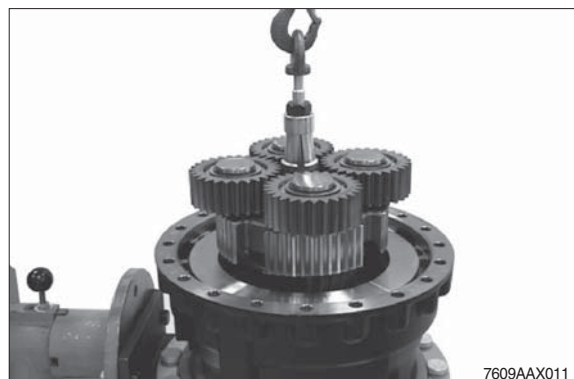

- ⑪ Pull the tapered roller bearing from the planetary carrier.

Rapid grip

5873 014 016

Basic tool

5873 004 001



- ⑫ Disengage retaining ring.



- ⑬ Pull off planetary gear.



- ⑭ Lift the end plate out of the brake housing.

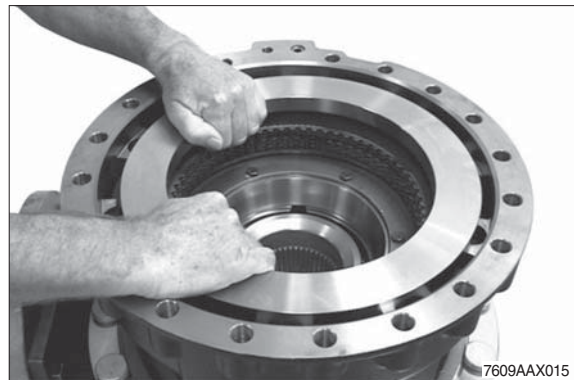



- ⑮ Lift the disk package out of the brake housing.

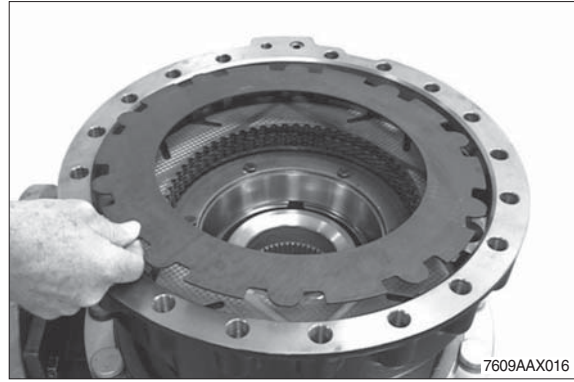

- ⑯ Loosen hexagon screws, remove releasing cover and cup spring.

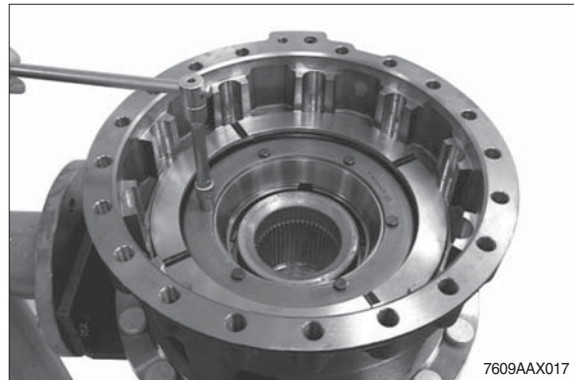

- ⑰ Mount breather valve and press piston out of the brake housing by means of compressed air.

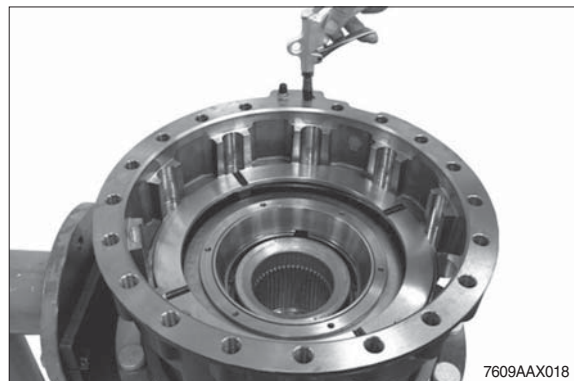

- ⑱ If necessary, remove guide ring, back-up rings and grooved rings out of the annular grooves of the brake housing (see arrows).

- ※ For the installation position of the single parts please also refer to the following sketch.

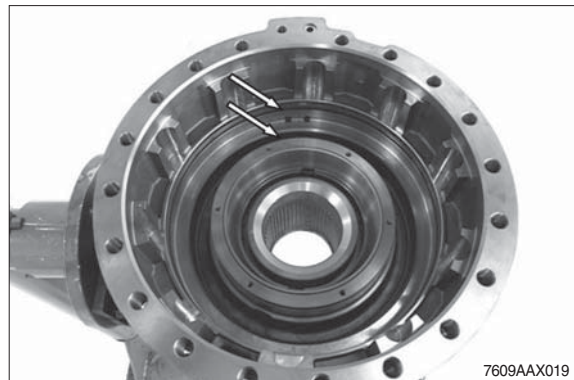

- 1 Brake housing
- 2 Guide ring
- 3 Back-up ring
- 4 Grooved ring
- 5 Grooved ring
- 6 Back-up ring
- 7 Slide ring seal
- 8 Output shaft

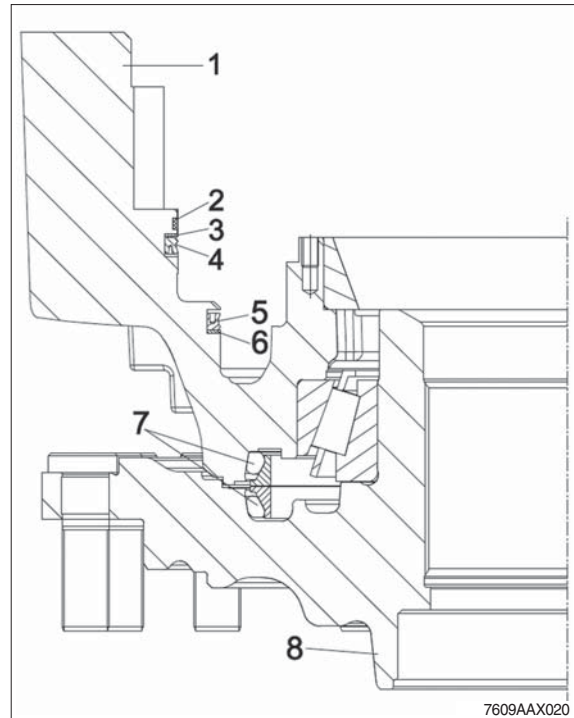

7609AAX020

- ①⑨ Lift the brake housing from the output shaft by means of the lifting device.



7609AAX021

- ②⑩ Use a lever to remove the slide ring seal from the brake housing.

If necessary, force out both bearing outer rings.

Resetting device                      5870 400 001



7609AAX022

- ① Use a lever to remove the slide ring seal from the output shaft.

Resetting device                      5870 400 001

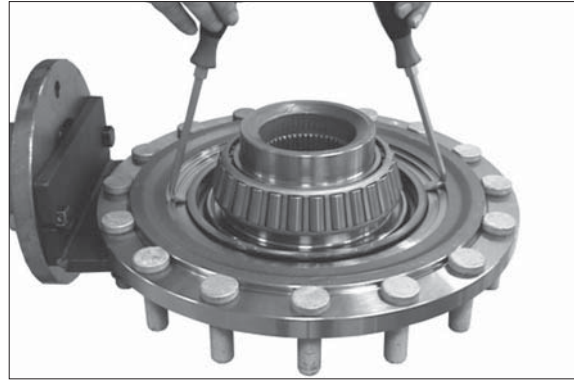

7609AAX023

- ② Pull the tapered roller bearing from the output shaft.

Rapid grip                              5873 014 013  
Basic tool                                5873 004 001

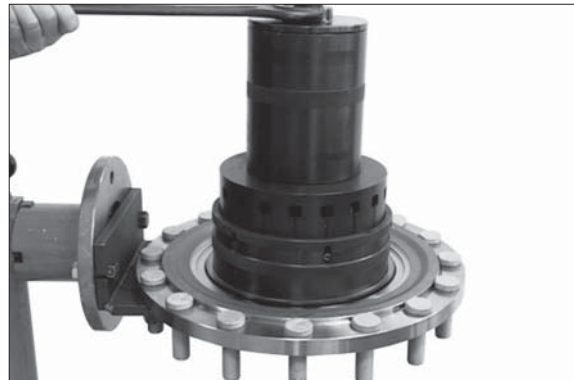

7609AAX024

## (2) Disassembly axle housing

- ① Secure axle housing with the lifting device and loosen the hexagon screws.

Then separate the axle housing from the axle drive housing.

- ※ Pay attention to releasing differential.

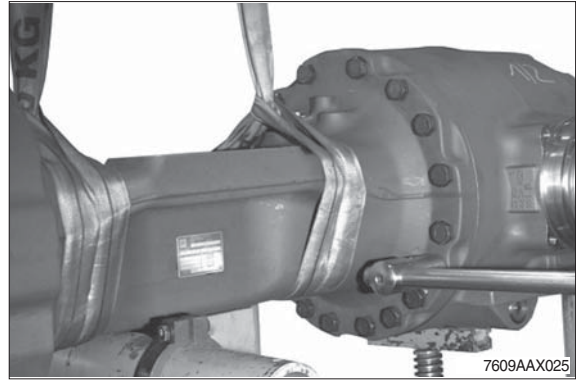

- ② Loosen the threaded connections and remove the releasing brake tube.

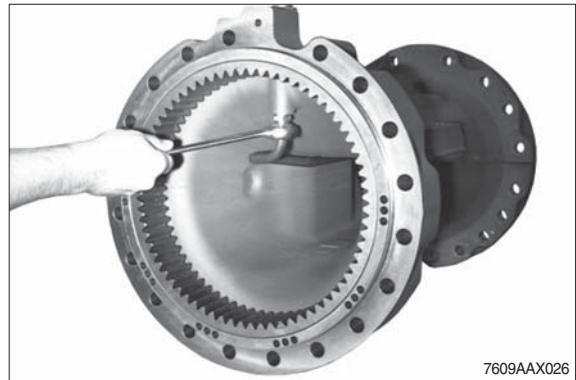

- ③ Loosen screw neck.

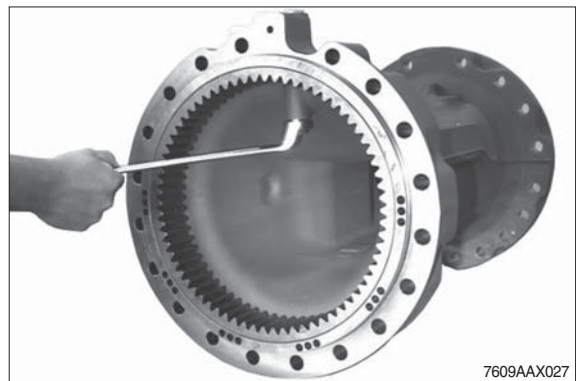

- ④ Pull the bearing outer ring out of the bearing hole and remove the shim behind.

Then remove the O-ring (see arrow).

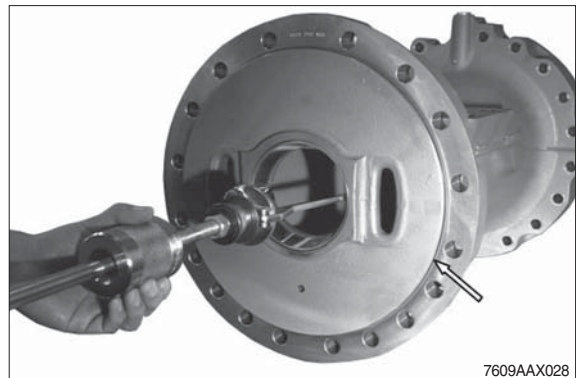

### (3) Disassembly input

- ① Use the lifting device to lift the differential out of the axle drive housing.

Load carrying fixture      5870 281 083

- ※ Disassembly of the differential is described as of page 3-213.

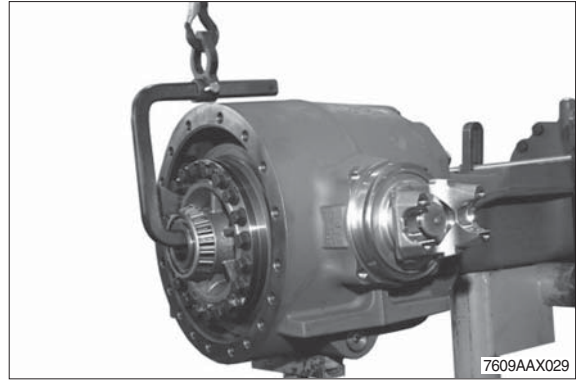

- ② Pull the bearing outer ring (see arrow) out of the housing hole and remove the shim behind.

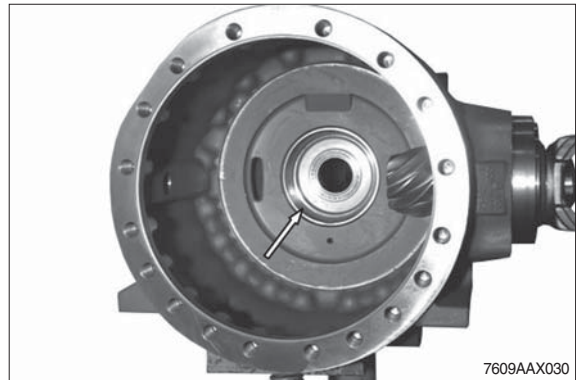

- ③ Press piston (see arrow) out of the axle housing (see subsequent figure) by means of compressed air.

- ※ This operation is only necessary for the hydraulic lock differential (option).

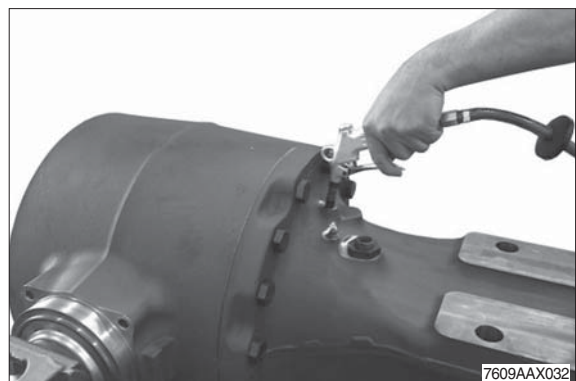
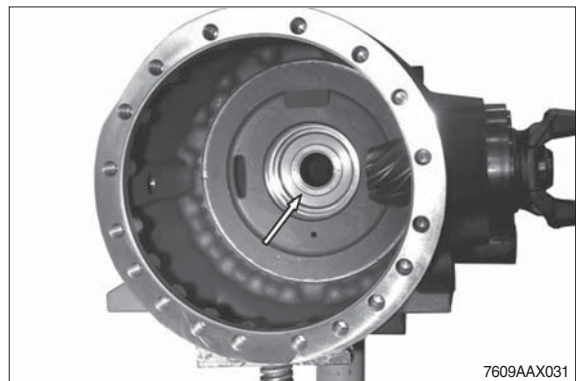



④ Heat slotted nut by means of hot air blower.

※ Slotted nut is secured with loctite (type No. : 262).

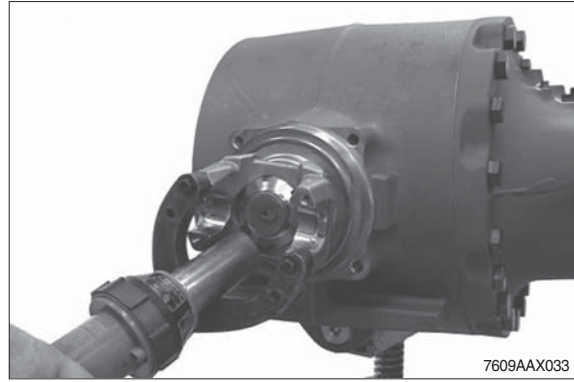

⑤ Loosen slotted nut and remove the shim behind.

Slotted nut wrench            5870 401 139  
Clamping device            5870 240 002



⑥ Pull the input flange from the input pinion and use a lever to remove the shaft seal behind from the axle drive housing.

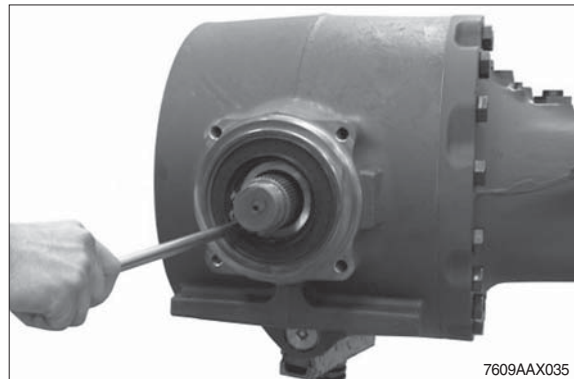

⑦ Press input pinion from the axle drive housing and remove the releasing tapered roller bearing.

Extractor            5870 000 065  
Hexagon screw (2EA)    AA00 331 360

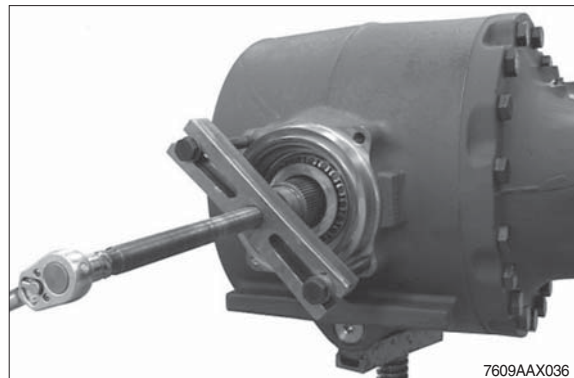

- ⑧ Remove spacer ring and pull the tapered roller bearing from the input pinion.

Gripping device            AA00 684 425  
Basic tool                    5873 002 000



- ⑨ If necessary, force both bearing outer rings out of the axle drive housing.

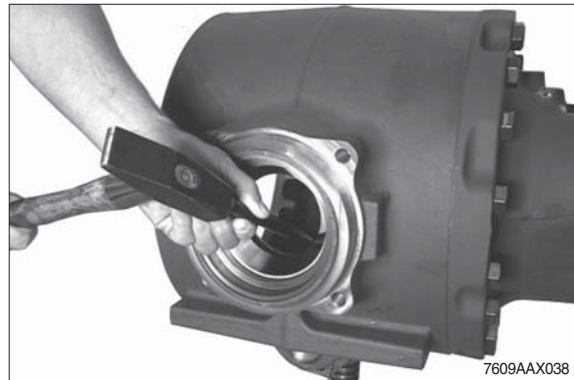

#### (4) Disassembly differentials

##### Disassembly hydraulic lock differential (option)

- ① Remove axial roller cage (arrow).



- ② Pull both tapered roller bearings from the differential.

##### Crown wheel side

Grab sleeve 5873 012 016

Basic tool 5873 002 001

##### Opposite side

Grab sleeve 5873 003 029

Basic tool 5873 002 001

Reduction 5873 003 011

Pressure piece 5870 100 075



- ③ Preload the differential by means of the press, loosen the hexagon screws and remove the releasing housing cover.

Pressure piece 5870 100 075

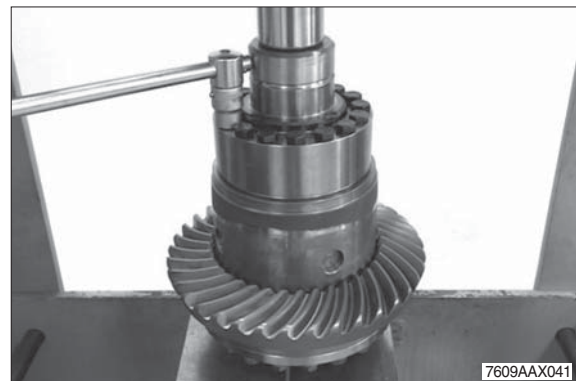

- ④ Preload the housing cover/compression spring by means of the press and disengage the retaining ring.

Then remove sliding sleeve and compression spring from the housing cover.





⑤ Remove single parts.

- 1 Pressure piece
- 2 Cage
- 3 Lever (12EA)
- 4 Disk carrier
- 5 Disk package

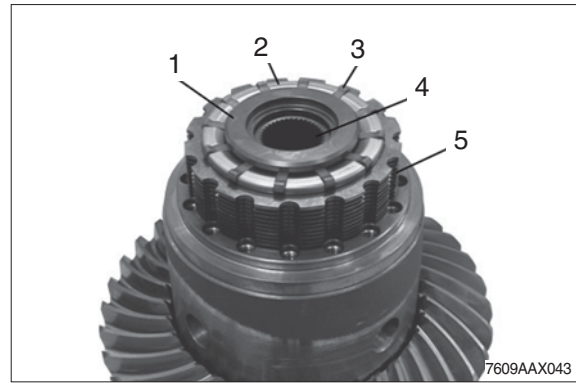

⑥ Preload differential by means of the press, loosen locking screws and housing cover.

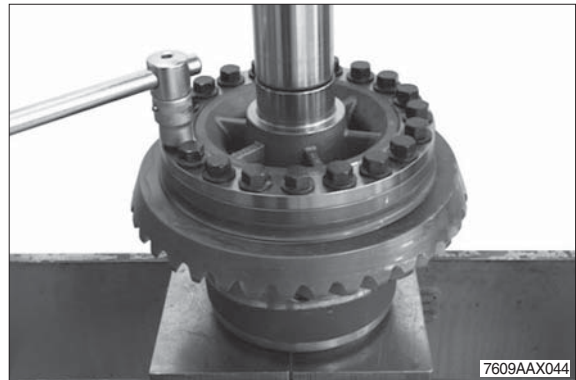

⑦ Remove axle bevel gear with thrust washers from the differential housing.



⑧ Force out both slotted pins.



- ⑨ Force out both differential axles (short) and remove the releasing spider gears with thrust washers from the differential housing.

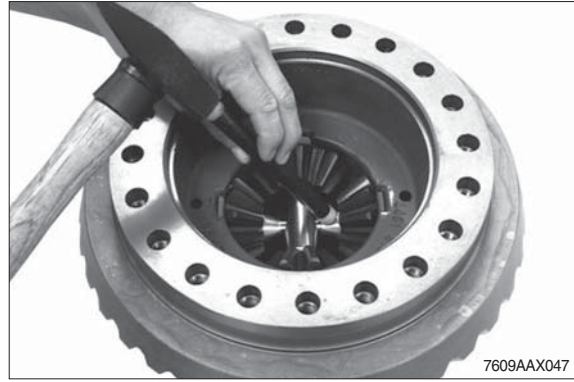

- ⑩ Pull the differential axle (long) and remove the releasing spider gears with thrust washers from the differential housing.



- ⑪ Remove the axle bevel gear and the shim behind.



- ⑫ Press crown wheel from the differential carrier.

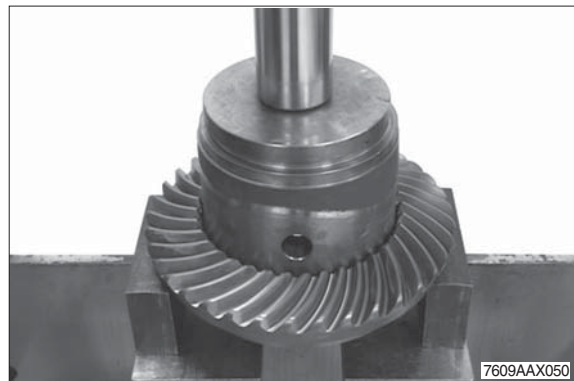

**Disassembly conventional differential (if equipped)**

- ① Pull both tapered roller bearings from the differential.

Grab sleeve 5873 012 016

Basic tool 5873 002 001



- ② Preload the differential by means of the press, loosen the hexagon screws and remove the releasing housing cover.



- ③ Preload the differential by means of the press, loosen locking screws and housing cover.

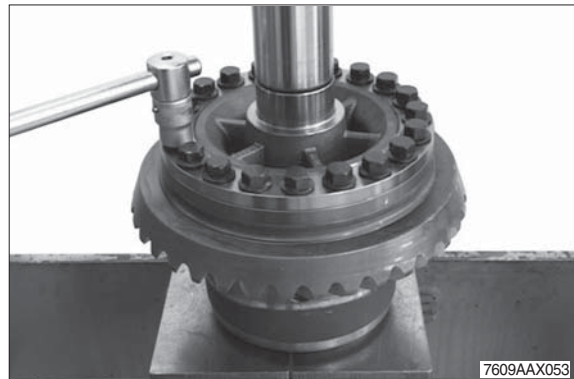

- ④ Remove axle bevel gear with thrust washers from the differential housing.



- ⑤ Force out both slotted pins.



- ⑥ Force out both differential axles (short) and remove the releasing spider gears with thrust washers from the differential housing.



- ⑦ Pull the differential axle (long) and remove the releasing spider gears with thrust washers from the differential housing.



- ⑧ Remove the axle bevel gear and the shim behind.



- ⑨ Press crown wheel from the differential carrier.

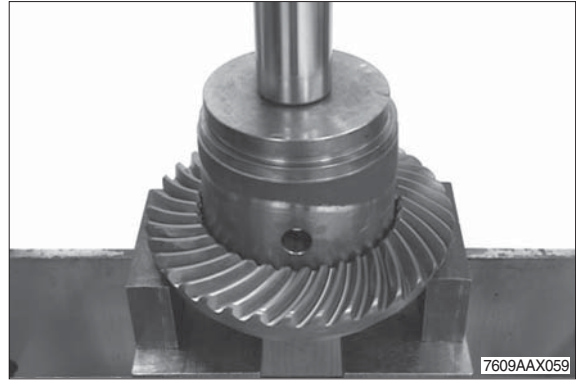

### Disassembly limited slip differential (standard)

- ① Pull both tapered roller bearings from the differential.

Grab sleeve                    5873 012 016  
Basic tool                    5873 002 001



- ② Preload the differential by means of the press, loosen locking screws and housing cover.

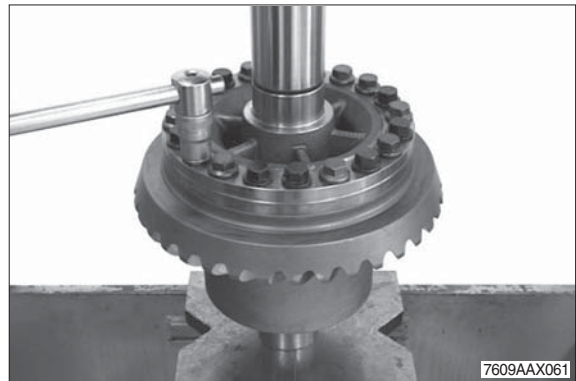

- ③ Lift the axle bevel gear with pressure ring, disk package and thrust washers out of the differential housing.





- ④ Remove spider shafts and axle bevel gears (see figure) out of the differential housing.



- ⑤ Remove the second axle bevel gear.



- ⑥ Lift the pressure ring out of the differential housing and remove the disk package and thrust washers behind.



- ⑦ Press crown wheel from the differential carrier.

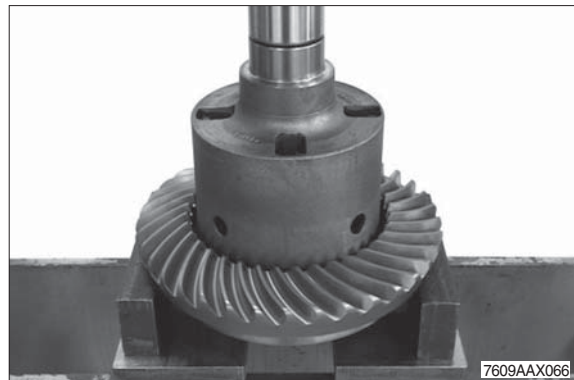

## (5) Reassembly differentials

### Reassembly hydraulic lock differential (option)

- ① Mount two locating pins and press the heated crown wheel onto the differential housing until contact is obtained.

Locating pins                      5870 204 040

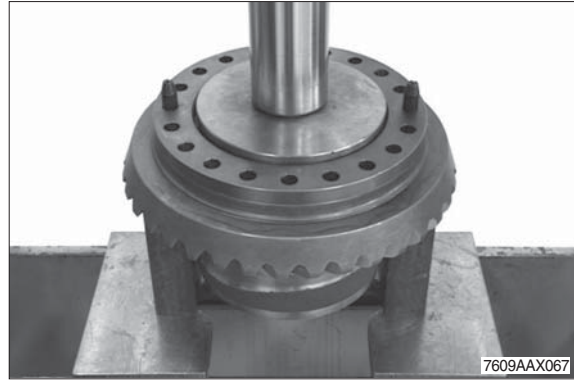

- ② Insert thrust washer into the differential housing.



- ③ Insert axle bevel gear.



- ④ Insert spider gears with thrust washers into the differential housing and fix them with the spider shaft (long).

※ Thrust washers must be positioned with the tabs (see arrow) being located in the recesses of the differential housing.





⑤ Insert spider gears with thrust washers into the differential housing and fix them with the two spider shafts (short).

※ Thrust washers must be positioned with the tabs (see arrow 1) being located in the recesses of the differential housing.

※ Pay attention to radial installation position of the spider shafts (fixing holes, arrow 2).

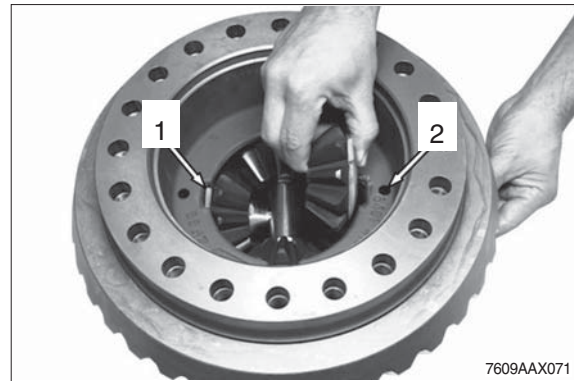

⑥ Fix spider shafts (short) with slotted pins.

※ Flush mount slotted pins.

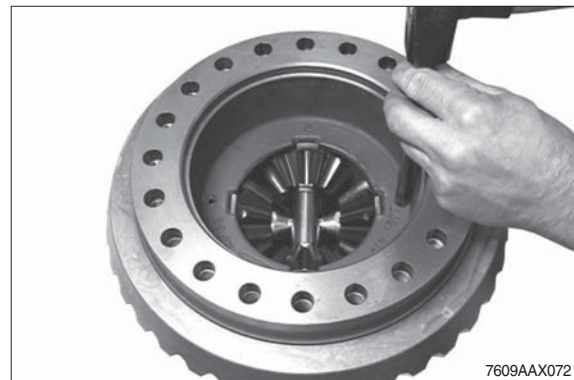

⑦ Mount second axle bevel gear.

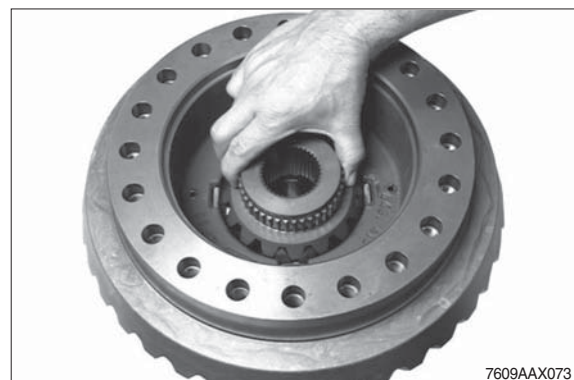

⑧ Fix the thrust washers into the housing cover by means of grease.

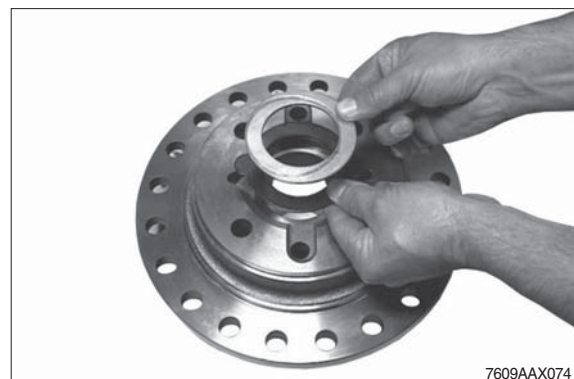

- ⑨ Mount two adjusting screws and insert the housing cover until contact with the differential housing is obtained.

Locating pins 5870 204 040

Preload the differential by means of the press and bolt with new locking screws.

- Tightening torque (M16/12.9) :  
40.8 kgf · m (295 lbf · ft)

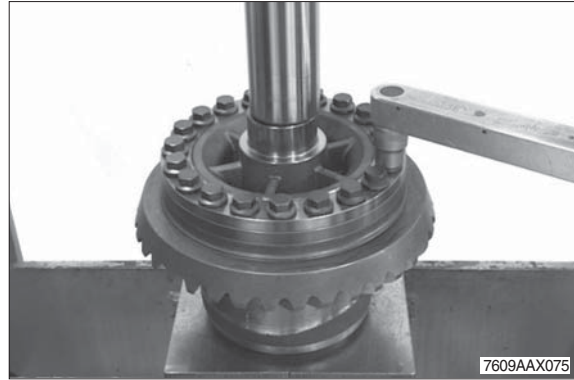

- ⑩ Install compression spring onto the sliding sleeve.



- ⑪ Insert the premounted sliding sleeve into the housing cover.

Preload the compression spring by means of the press and engage the retaining ring into the annular groove of the sliding sleeve.



### Setting of disk package

- ⑫ Premount single parts according to the adjacent sketch.

- 1 Housing cover
- 2 Pressure piece
- 3 Cage
- 4 Lever (12EA)
- 5 Disk carrier
- 6 Pressure ring
- 7 Inner disks
- 8 Outer disks (optional)
- 9 Snap ring

- ※ For the number of disks and the disk arrangement please refer to the relating parts manual.

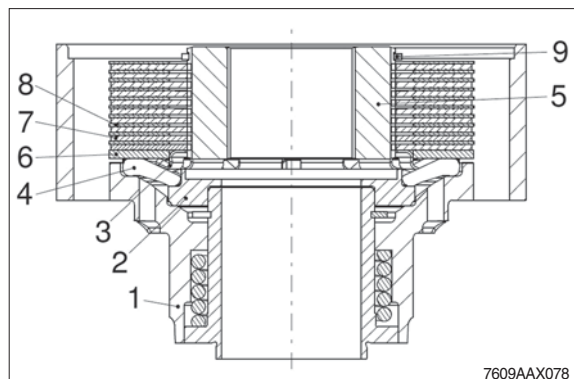

- ⑬ Preload disk package with an axial force of  $F = 50^{+30}$  kN.  
Then check the setting dimension "A" =  $1.05 \pm 0.1$  mm from the collar of the differential cover to the plane face of the outer disk (see also below sketch).

Pressure piece                    5870 100 069  
Load cell                            5870 700 004

- ※ Any deviation from the specified setting dimension must be corrected with a corresponding outer disk.

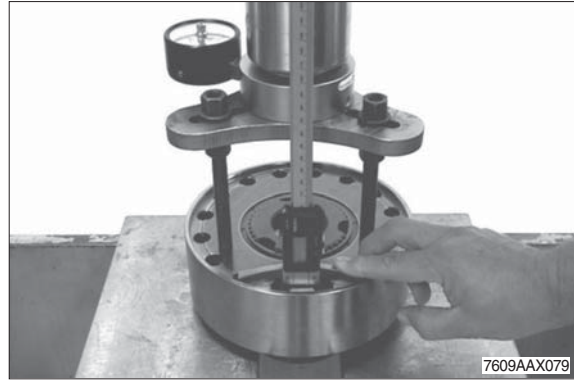

7609AAX079

A = Setting dimension =  $1.05 \pm 0.1$  mm  
B = Contact face

- ⑭ To obtain a correct measuring result :  
The housing cover may only be supported on the contact face (B).  
Ensure that the assembly fixture is only supported on the disk package and not on the disk carrier (5).

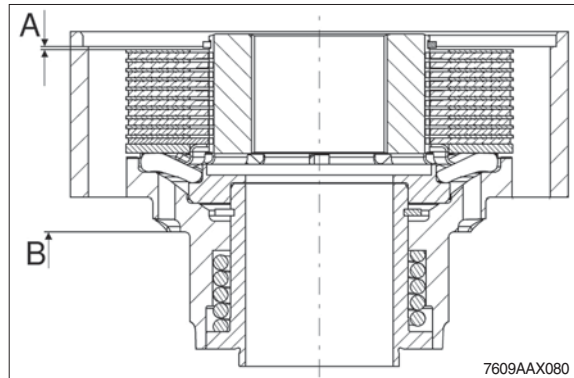

7609AAX080

- ⑮ Position housing cover onto pressure piece (see arrow).  
Insert two hexagon screws into the housing cover to radially fix the disk package.

Pressure piece                    5870 100 075



7609AAX081

- ⑯ Position the premounted differential with the lifting device onto the housing cover and preliminarily fix with hexagon screws.

Lifting device                    AA00 331 446



7609AAX082

- ⑰ Preload the differential by means of the press and the pressure piece.

Then finally tighten the housing cover with hexagon screws.

· Tightening torque (M14/10.9) :  
18.9 kgf · m (136 lbf · ft)

Pressure piece 5870 100 075

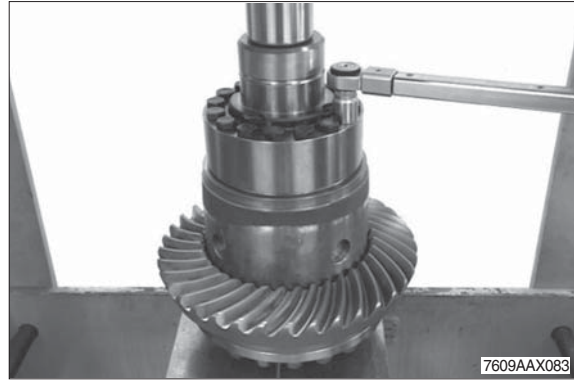

- ⑱ Heat both tapered roller bearings and insert until contact is obtained.

※ Adjust tapered roller bearing after cooling down.



- ⑲ Fix axial roller cage (see arrow) to the sliding sleeve by means of grease.



**Reassembly conventional differential (if equipped)**

- ① Mount two locating pins and press the heated crown wheel onto the differential housing until contact is obtained.

Locating pins                      5870 204 040

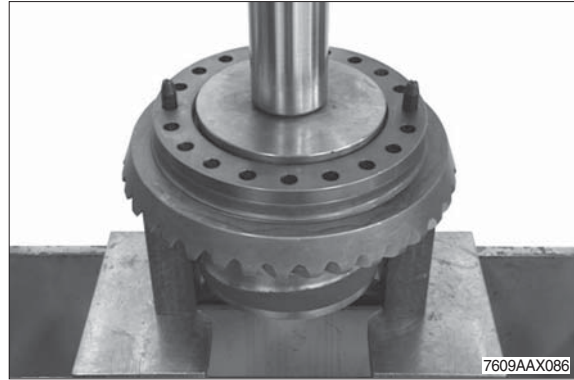

- ② Insert thrust washer into the differential housing.



- ③ Insert axle bevel gear.



- ④ Insert spider gears with thrust washers into the differential housing and fix them with the spider shaft (long).

※ Thrust washers must be positioned with the tabs (see arrow) being located in the recesses of the differential housing.





⑤ Insert spider gears with thrust washers into the differential housing and fix them with the two spider shafts (short).

※ Thrust washers must be positioned with the tabs (see arrow 1) being located in the recesses of the differential housing.

※ Pay attention to radial installation position of the spider shafts (fixing holes, arrow 2).

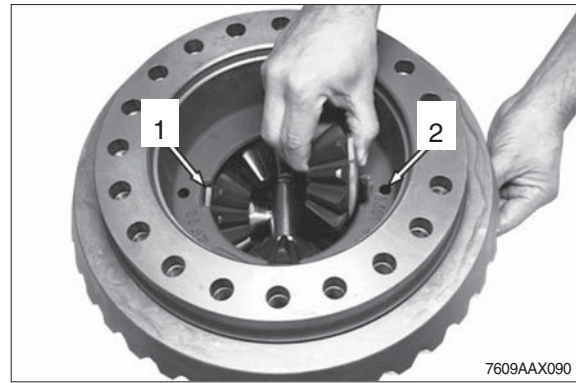

⑥ Fix spider shafts (short) with slotted pins.

※ Flush mount slotted pins.



⑦ Mount second axle bevel gear.

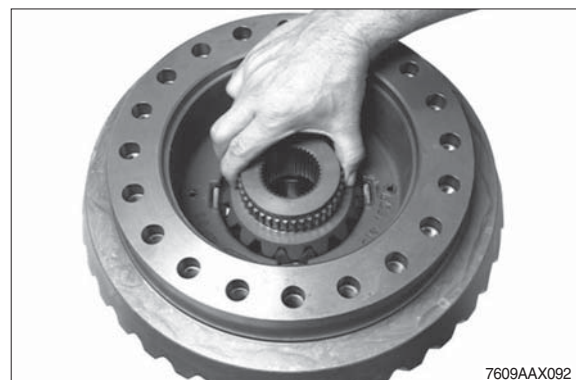

⑧ Fix the thrust washers into the housing cover by means of grease.

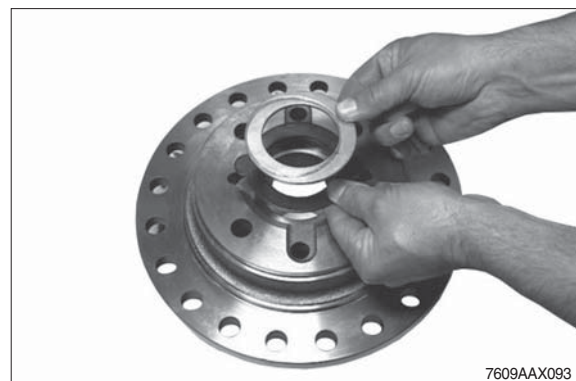

- ⑨ Mount two adjusting screws and insert the housing cover until contact with the differential housing is obtained.

Locating pins 5870 204 040

Preload the differential by means of the press and bolt with new locking screws.

- Tightening torque (M16/12.9) :  
40.8 kgf · m (295 lbf · ft)

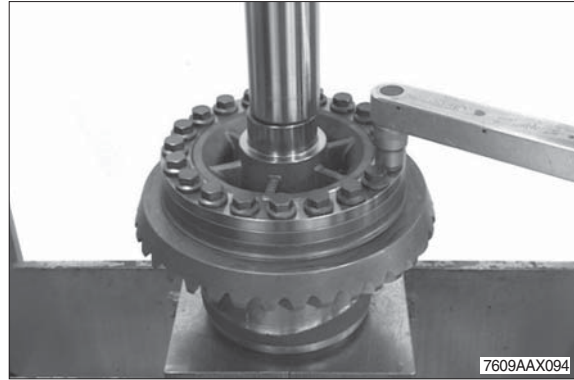

- ⑩ Attach the housing cover and preload the differential with the press.

Then fix the housing cover with hexagon screws.

- Tightening torque (M14/10.9) :  
18.9 kgf · m (136 lbf · ft)

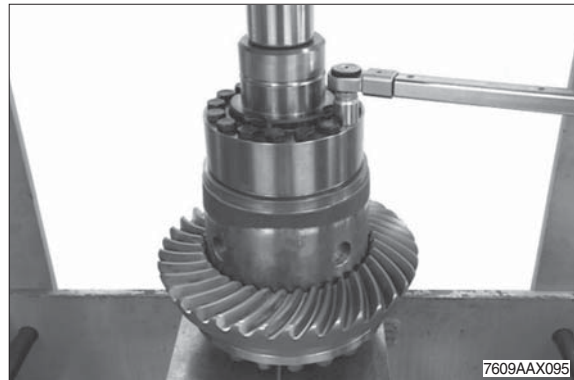

- ⑪ Heat both tapered roller bearings and insert until contact is obtained.

- ※ Adjust tapered roller bearing after cooling down.





## Reassembly limited slip differential (standard)

- ① Mount two locating pins and press the heated crown wheel onto the differential housing until contact is obtained.

Locating pins                      5870 204 040

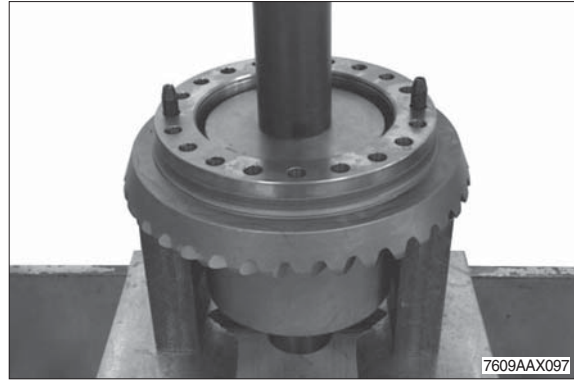

- ② Insert thrust washer into the differential housing.



- ③ Mount outer and inner disks in alternating order, starting with an outer disk.

※ The installation clearance of the internal parts is corrected by mounting outer disks with different thicknesses.

**▲ The difference in thickness between the left and the right disk package must only be 0.1 mm at maximum.**



- ④ Place the pressure ring.



- ⑤ Insert the axle bevel gear until contact is obtained and install the inner disks with the teeth.



- ⑥ Preassemble the differential spider and insert it into the differential housing/into the pressure ring.



- ⑦ Mount second axle bevel gear.



- ⑧ Insert the second pressure ring into the differential housing.



- ⑨ Mount outer and inner disks in alternating order, starting with an inner disk.

The installation clearance of the internal parts is corrected by mounting outer disks with different thicknesses.

**▲ The difference in thickness between the left and the right disk package must only be 0.1 mm at maximum.**

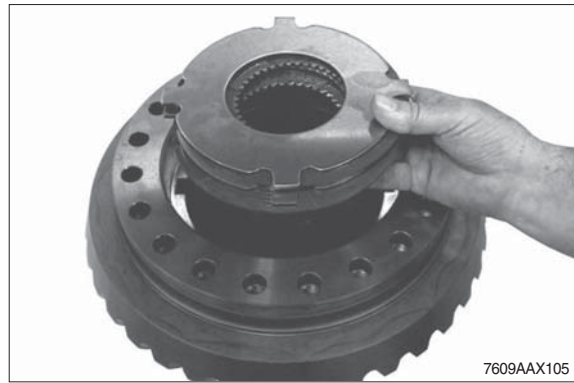

**Determine the installation clearance 0.2~0.7 mm**

- ⑩ Measure dimension I, from the mounting face of the differential housing to the plane face of the outer disk.

Dimension I e.g. .... 44.30 mm



- ⑪ Measure dimension II, from the contact face of the outer disk to the mounting face on the housing cover.

Dimension II e.g. .... 43.95 mm

**CALCULATION EXAMPLE :**

Dimension I ..... 44.30 mm

Dimension II ..... - 43.95 mm

**Difference = disk clearance = 0.35 mm**

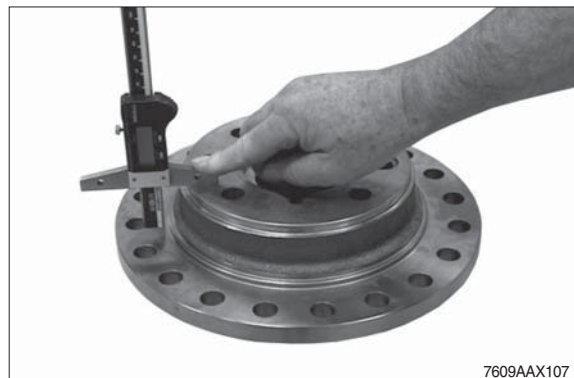

※ Any deviation from the required installation clearance is to be corrected with corresponding outer disks (s = 2.7, s = 2.9, s = 3.0, s = 3.1, s = 3.2, s = 3.3 or s = 3.5 mm), taking care that the difference in thickness between the left and the right disk package must only be 0.1 mm at maximum.

- ⑫ Fix the thrust washers into the housing cover by means of grease.



- ⑬ Mount two adjusting screws and insert the housing cover until contact with the differential housing is obtained.

Locating pins                      5870 204 040

Preload the differential by means of the press and bolt with new locking screws.

- Tightening torque (M16/12.9) :  
40.8 kgf · m (295 lbf · ft)

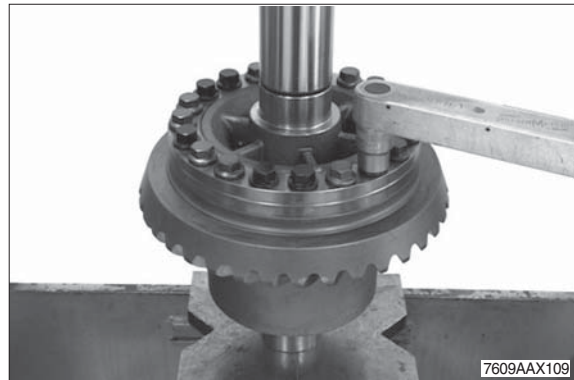

- ⑭ Heat both tapered roller bearings and insert until contact is obtained.

- ※ Adjust tapered roller bearing after cooling down.



## (6) Reassembly input

※ If crown wheel or input pinion are damaged, both parts must be jointly replaced.

In case of a new installation of a complete bevel gear set pay attention to an identical mating number of input pinion and crown wheel.

### Determination of shim thickness to obtain a correct contact pattern

※ The following measuring procedures must be carried out with utmost accuracy.

Inaccurate measurements lead to an incorrect contact pattern requiring an additional disassembly and reassembly of input pinion and differential.

① Read dimension I from the axle drive housing.

Dimension I e.g. .... 221.10 mm

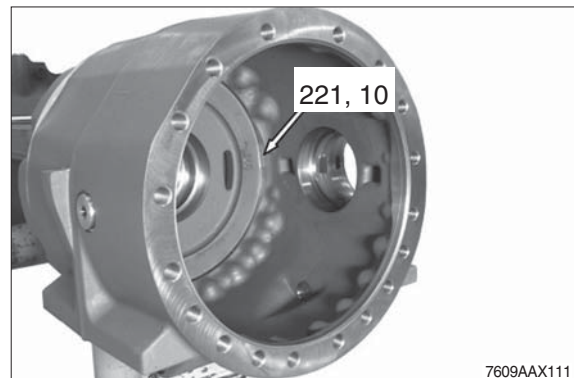

② Read dimension II (pinion dimension).

Dimension II e.g. .... 181.00 mm



- ③ Determine dimension III (bearing width).

Dimension III e.g. .... 39.10 mm

CALCULATION EXAMPLE "A<sub>11</sub>":

Dimension I ..... 221.10 mm

Dimension II ..... - 181.00 mm

Dimension III ..... - 39.10 mm

**Difference = shim                      s = 1.00 mm**

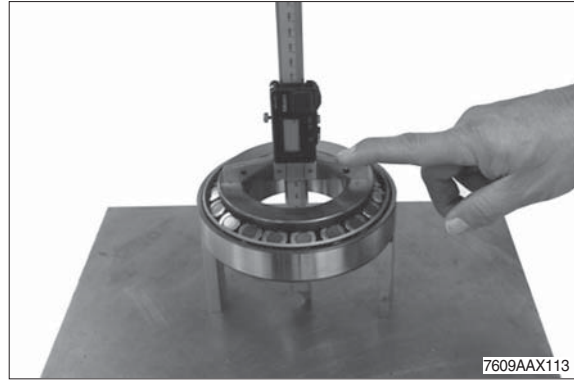

### Reassembly of input pinion

- ④ Undercool the external bearing outer ring and insert it into the axle drive housing until contact is obtained.

Driver tool                                      5870 058 079

Handle    5870 260 004

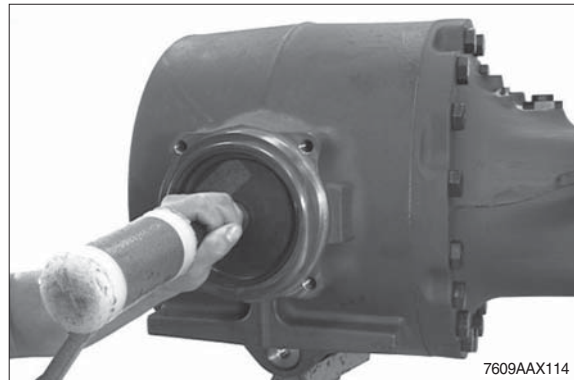

- ⑤ Insert the determined shim e.g. s = 1.00 mm into the housing hole.

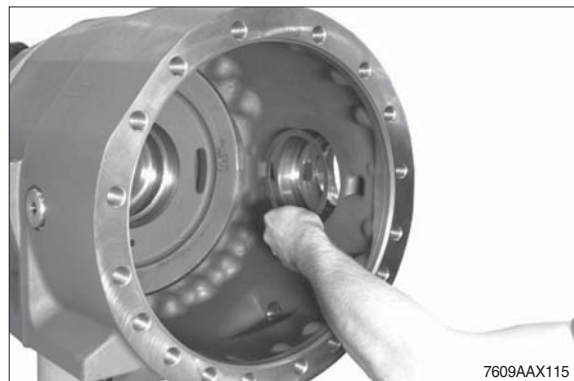

- ⑥ Undercool the internal bearing outer ring and bring it into contact position in the housing hole by using the assembly fixture.

Assembly fixture                                5870 345 080





- ⑦ Heat the tapered roller bearing and insert it into the input pinion until contact is obtained.



**Setting of rolling torque of input pinion bearing 0.15~0.41 kgf · m (1.11~2.95 lbf · ft) (without shaft seal)**

- ⑧ Insert spacer (e.g.  $s = 8.18$  mm).
- ※ According to our experience the necessary rolling torque is obtained when reusing the spacer which has been removed during disassembly (e.g.  $s = 8.18$  mm).  
A later check of the rolling torque, however, is absolutely necessary.



- ⑨ Insert the preassembled input pinion into the axle drive housing and insert the heated tapered roller bearing until contact is obtained.

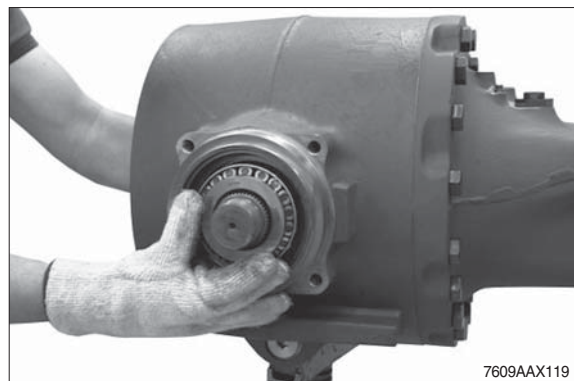

- ⑩ Press the protection plate onto the input flange (see arrow) until contact is obtained.
- ※ Do not fit the shaft seal until the contact pattern has been checked.

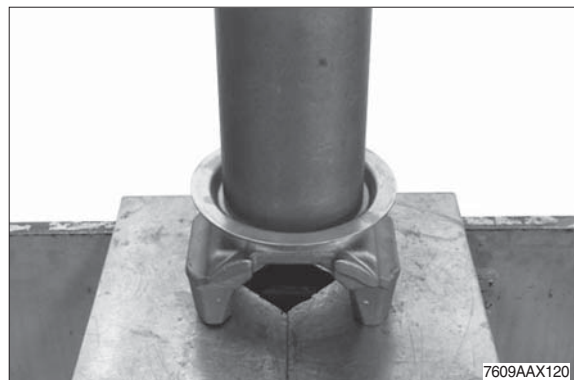



- ⑪ Insert input flange and fix it by means of disk and slotted nut.

· Tightening torque :

122 kgf · m (885 lbf · ft)

Slotted nut wrench            5870 401 139

Clamping device                5870 240 002

- ※ Preliminarily mount slotted nut without loctite.

**▲ While tightening rotate the input pinion several times in both directions.**

- ⑫ Check rolling torque (0.15~0.41 kgf · m without shaft seal).

- ※ When installing new bearings try to achieve the upper value of the rolling torque.

**▲ In case of deviations from the necessary rolling torque correct with a corresponding spacer (AX118, page 3-234) as specified below.**

**Insufficient rolling torque**

**install thinner spacer ring**

**Excessive rolling torque**

**install thicker spacer ring**

- ⑬ Grease O-rings (2EA, see arrows) and insert them into the annular grooves of the piston.

- ※ Operation figure AX123 and AX124 is only necessary for hydraulic lock differential (option).



- ⑭ Insert piston (see arrow) into the bearing housing until contact is obtained.

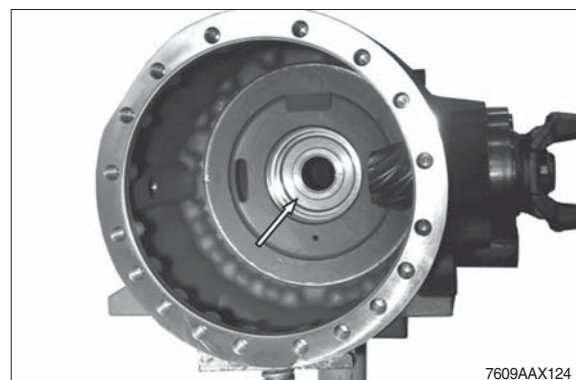

**Determination of shims for setting of bearing rolling torque (differential housing) and backlash (bevel gear set)**

- ※ Determine the required shims on the basis of the read value (deviation/test dimension) and the corresponding specifications of the table below :  
 (KRS – SET – RIGHT)  
 (KRS = bevel gear set)



⑮ Deviation see crown wheel rear side.

- ※ The test dimension “101,, is stamped into the crown wheel rear side. If no + or – deviation is indicated, this value corresponds to the actual value “0” in the table below.  
 According to this value, the required shims are allocated in the table below.

Any + or – deviation of the test dimension caused by production is also marked on the crown wheel rear side (e.g. - 20 or - 10 or 10 or 20).  
 In accordance with this deviation, the required shims are allocated in the table below.

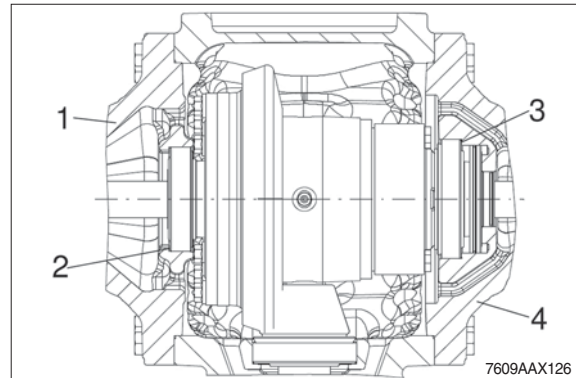

- 1 Axle housing
- 2 Shim (crown wheel side)
- 3 Shim (differential carrier side)
- 4 Axle housing

Shims for differential				
Crown wheel marking	- 20	- 10	-	10
Deviation	- 0.2	- 0.1	0	0.1
<b>Shim Differential cage side Shim thickness</b>	<b>0.7</b>	<b>0.8</b>	<b>0.9</b>	<b>1.0</b>
Shim Hydraulic lock differential	ZGAQ-04367	ZGAQ-04167	ZGAQ-04168	ZGAQ-04169
Shim Conventional, L/slip differential	ZGAQ-04368	ZGAQ-03896	ZGAQ-03897	ZGAQ-03898
<b>Shim Crown wheel side Shim thickness</b>	<b>1.3</b>	<b>1.2</b>	<b>1.1</b>	<b>1.0</b>
Shim	ZGAQ-04369	ZGAQ-03900	ZGAQ-03899	ZGAQ-03898

- ⑩ Insert the determined shim (e.g.  $s = 0.9 \text{ mm}$ ) into the hole of the axle housing and adjust the bearing outer ring (see arrow) until contact is obtained.

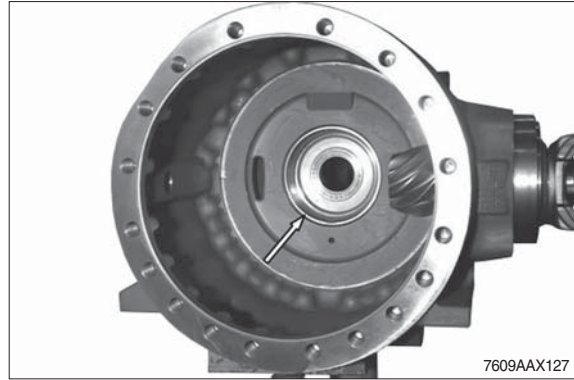

- ⑪ Cover some drive and coast flanks of the crown wheel with marking ink.  
Then insert the premounted differential into the axle drive housing.

Load carrying device      5870 281 083

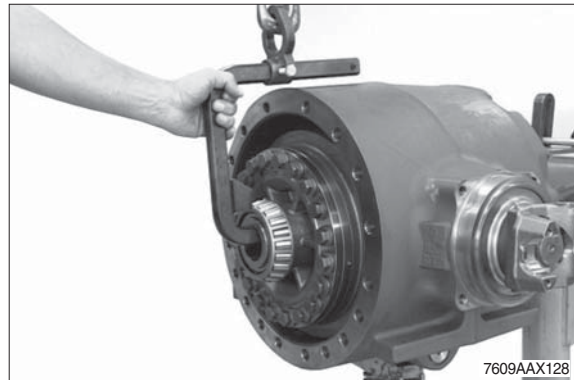

- ⑫ Insert the determined shim (e.g.  $s = 1.1 \text{ mm}$ ) into the hole of the axle housing and adjust the bearing outer ring (see arrow) until contact is obtained.

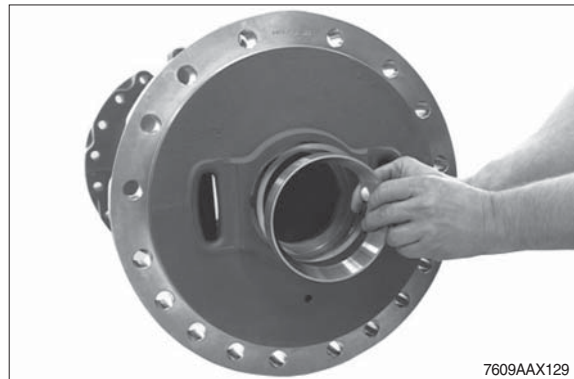

- ⑬ Mount two locating pins and bring the axle housing into contact position with the axle drive housing by means of the lifting device.

Locating pins      5870 204 024

Then preliminarily fix the axle housing with 4 hexagon screws.

- Tightening torque (M20/10.9) :  
 $57.1 \text{ kgf} \cdot \text{m}$  (413 lbf · ft)

- ※ Preliminarily mount the axle housing without O-ring.

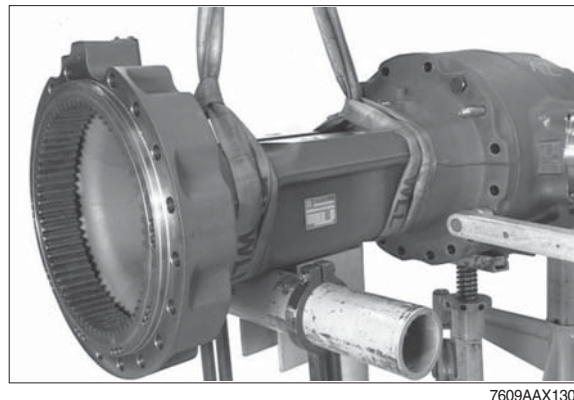

### Leakage test of lock

① Pressurize the lock ( $p = 1 \text{ bar}$ ), close shut-off valve and remove air line.

**▲ No noticeable pressure loss is allowed to occur within 10 sec.**

※ This operation is only necessary for hydraulic lock differential (option).

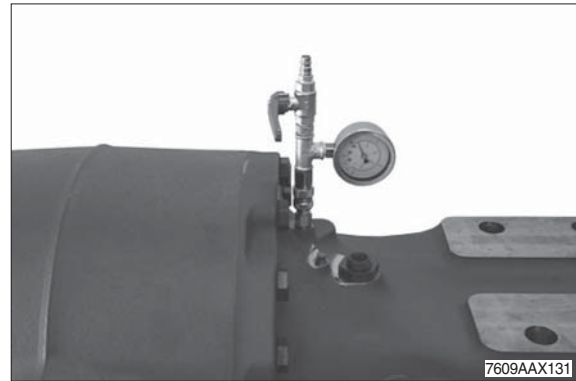

② By rotating the input flange, roll crown wheel over the input pinion in both directions several times.

Then remove the axle housing again and lift the differential out of the axle drive housing.

Compare the obtained contact pattern.

**▲ In case of any contact pattern deviation, a measuring error was made when determining the shim (AX115, page 3-233), which must be corrected by all means.**

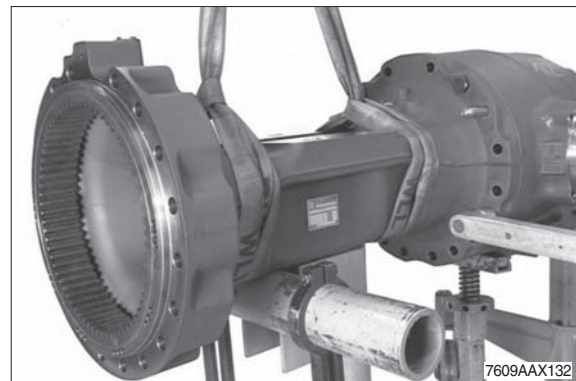

③ After the contact pattern check insert the differential again into the axle drive housing.

Load carrying device      5870 281 083

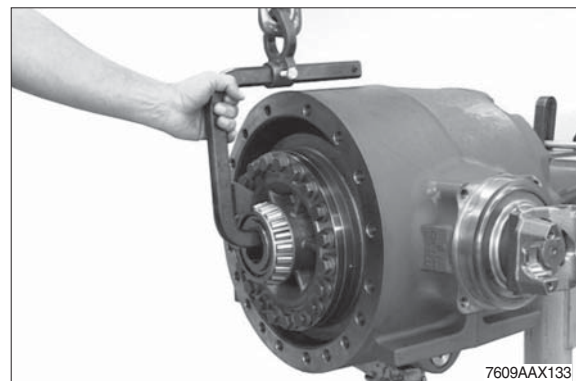

### Reassembly of shaft seal (figure AX134~136)

- ②③ Loosen the slotted nut and pull the input flange from the input pinion.

Slotted nut wrench            5870 401 139  
Clamping device                5870 240 002

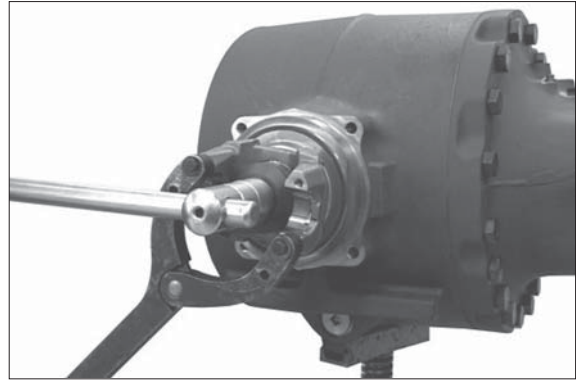

7609AAX134

- ②④ Mount the shaft seal with the seal lip showing to the oil chamber.

Driver tool                        5870 048 233

- ※ The exact installation position of the shaft seal is obtained when using the specified driver tool.
- ※ Wet the outer diameter of the shaft seal with spirit directly before installation and fill the space between seal and dust lip with grease.

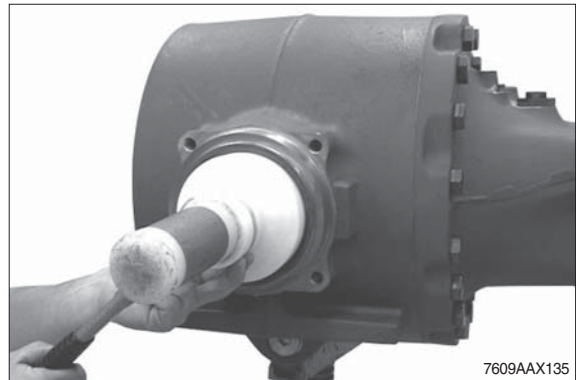

7609AAX135

- ②⑤ Insert input flange and finally tighten by means of disk and slotted nut.

· Tightening torque :  
122 kgf · m (885 lbf · ft)

Slotted nut wrench            5870 401 139  
Clamping device                5870 240 002

- ※ Cover the thread of the slotted nut with loctite (type no. : 262).



7609AAX136



## (7) Reassembly axle housing

- ① Grease O-ring (see arrow) and insert it into the axle housing.

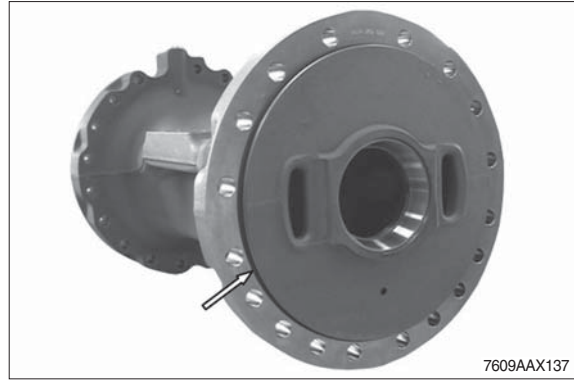

- ② Mount two locating pins and bring the axle housing into contact position with the axle drive housing by using the lifting device.

Then fix the axle housing by means of hexagon screws.

- Tightening torque (M20/10.9) :  
57.1 kgf · m (413 lbf · ft)

Locating pins                      5870 204 024

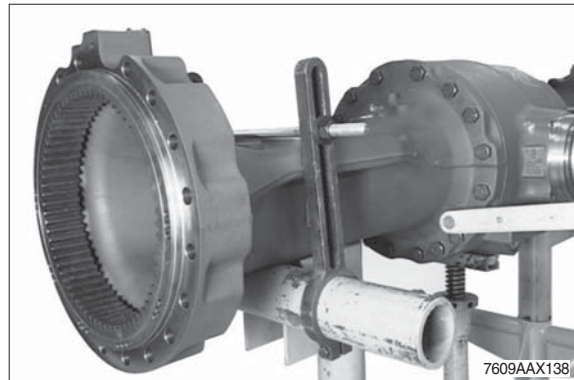

- ※ After assembling the axle housing secure the axle with clamping brackets.

- ③ Mount fitting.

- Tightening torque :  
3.67 kgf · m (26.6 lbf · ft)

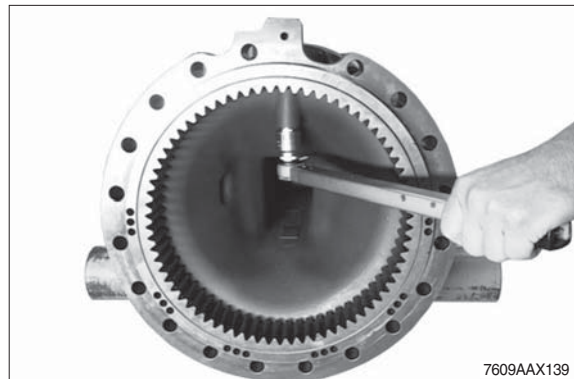

- ④ Grease O-ring and insert it into the annular groove of the brake tube (see arrow).

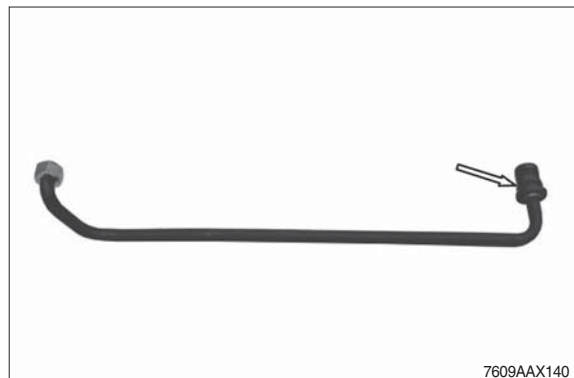

- ⑤ Mount brake tube with threaded connection and hexagon nut (see arrow).

· Tightening torque :  
10.2 kgf · m (73.8 lbf · ft)

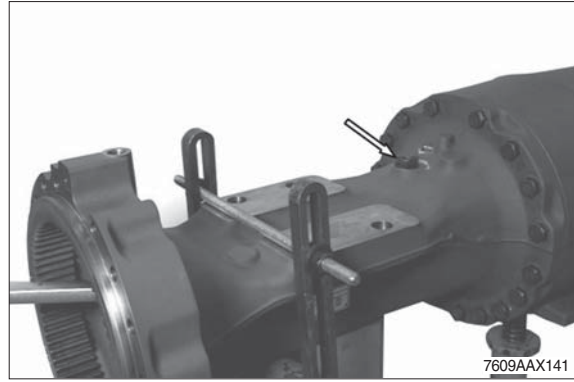

- ⑥ Provide screw plug with a new O-ring and fit it.

Flush mount slotted pins.

· Tightening torque :  
5.1 kgf · m (36.9 lbf · ft)

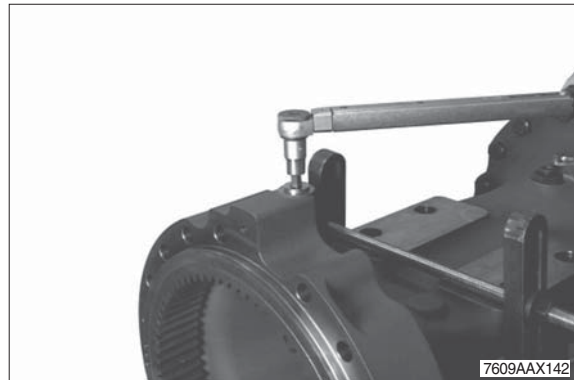



## (8) Reassembly output and brake

- ① Pull in wheel stud into the output shaft until contact is obtained.

Wheel stud puller-basic tool

5870 610 001

Insert (M22×1.5) 5870 610 002

Special tool may only be used for repair solution when exchanging individual wheel studs with mounted output shaft. When using a new output shaft, mount the wheel studs with the press.

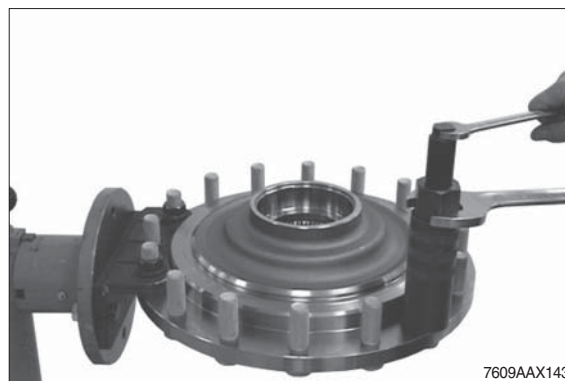

- ② Heat tapered roller bearing and insert it into the output shaft until contact is obtained.

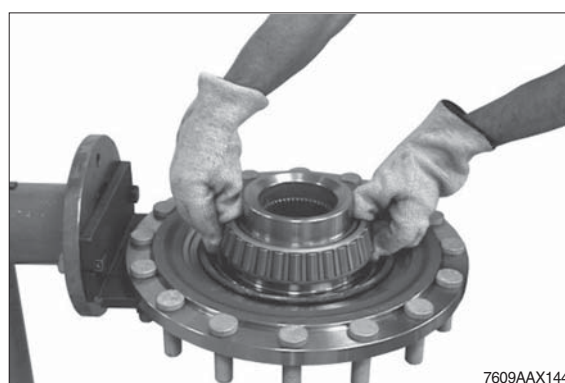

- ③ Wet O-ring of slide ring seal and locating hole with spirit.

Snap **new** slide ring seal (part 1) into the output shaft.

Then mount **new** slide ring seal (part 2) accordingly into the brake housing.

- ※ For the installation position of the seal please also refer to sketch, page 3-244.

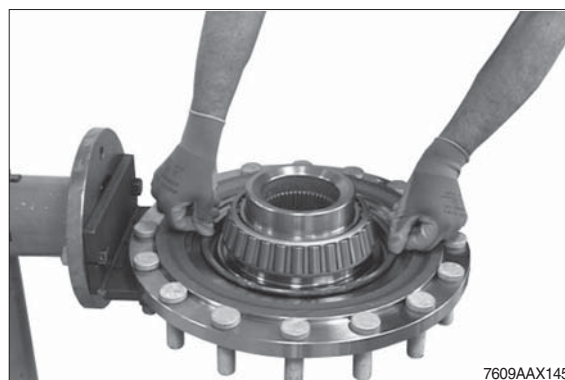

- ※ The surface of the slide ring seal may not have any grooves, scratches or other types of damage.

Take care that the sealing surface is parallel to the housing face.

The O-rings must be mounted evenly into the locating hole and must not bulge out of the hole.

- ▲ **Risk of injury-Metal rings have extremely sharp edges. Wear protective gloves.**



- ④ Insert both bearing outer rings (see arrows) into the brake housing until contact is obtained.



- ⑤ Insert the premounted brake housing by means of the lifting device over the output shaft until contact is obtained.

- ※ Before clamping the seal rings (slide ring seal) to installation dimension, clean the sliding surfaces and apply an oil film. We recommend to use a leather cloth soaked with oil.



- ⑥ Insert back-up rings and grooved rings into the annular grooves of the brake housing (see arrows).

- ※ Pay attention to the installation position; please also refer to sketch, page 3-244.

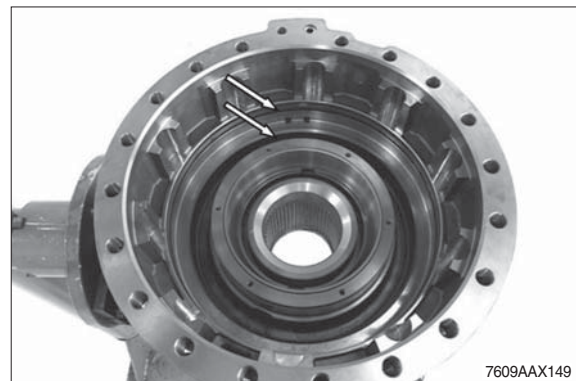

- ⑦ Clean the annular groove of the brake housing with spirit.

Then insert the guide ring into the annular groove (see also the following sketch) and fix it with loctite (type No. : 415) at its extremities (see arrows).

- ※ The full circumference of the guide ring must be in an exact contact position.

- ※ Upon installation the orifice of the guide ring must show upwards (12 o'clock).



- 1 Brake housing
- 2 Guide ring
- 3 Back-up ring
- 4 Grooved ring
- 5 Grooved ring
- 6 Back-up ring
- 7 Slide ring seal
- 8 Output shaft

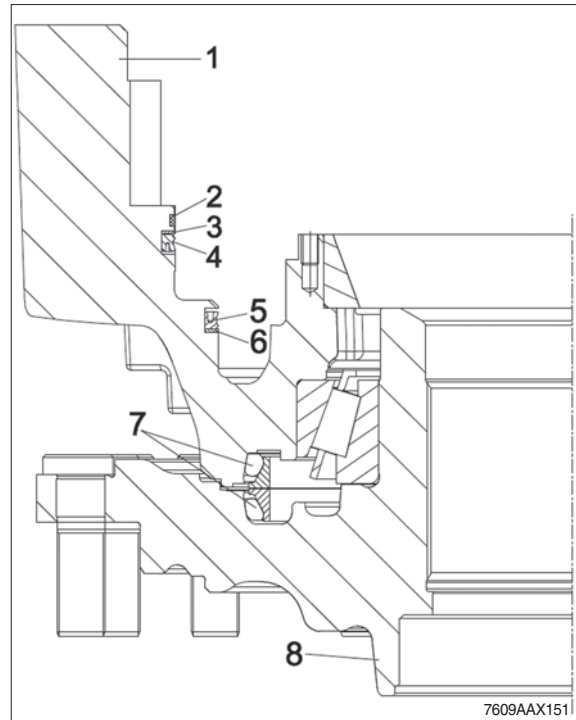

- ⑧ Flush-mount the slotted pins (6EA) into the holes of the piston.



- ⑨ Insert the piston into the brake housing and carefully install with the fixing device until contact is obtained.

Fixing device                      AA00 680 530

- ※ Sufficiently oil seal surface of piston/  
back-up rings, grooved rings and guide  
ring.

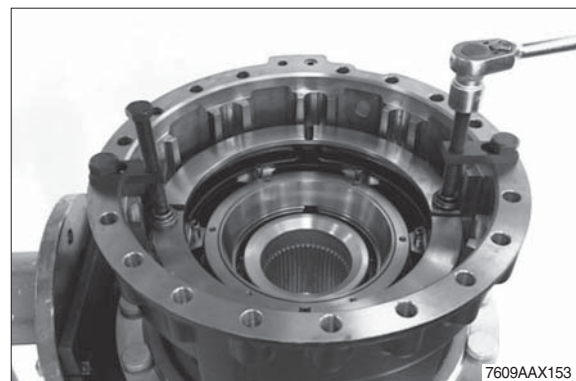

- ⑩ Insert disk and cup spring with the convex side showing upwards into the piston.

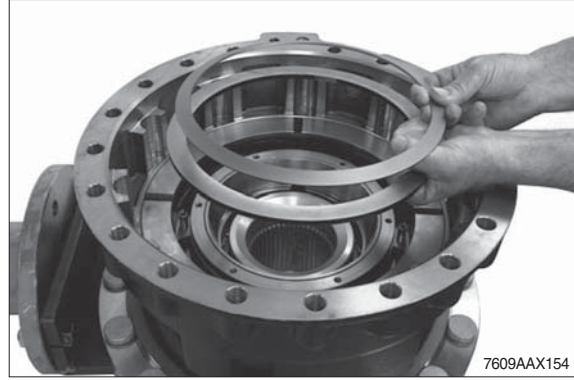

- ⑪ Insert cover and fix it by means of hexagon screws.

- Tightening torque (M8/10.9) :  
3.47 kgf · m (25.1 lbf · ft)

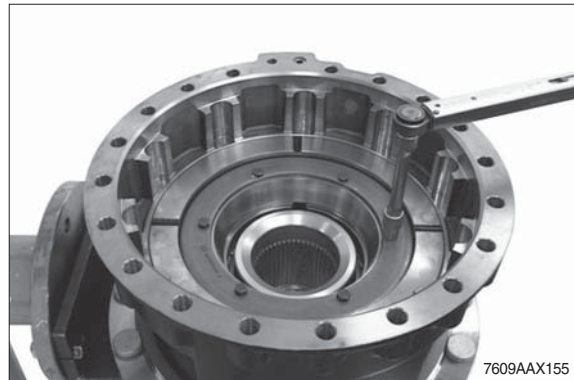

- ⑫ Mount outer and inner disks.

- ※ For the number of disks and the disk arrangement please refer to the relating parts manual.

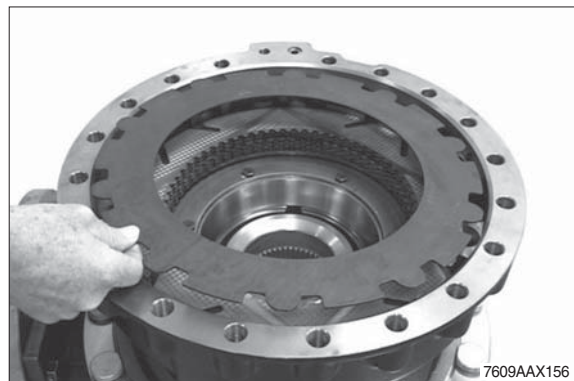

- ⑬ Insert end plate.

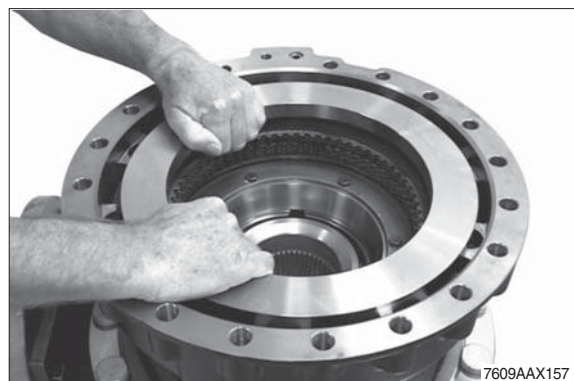



- ⑭ Press stop bolt into the planetary carrier until contact is obtained.

- 1 Stop bolt
- 2 Planetary carrier

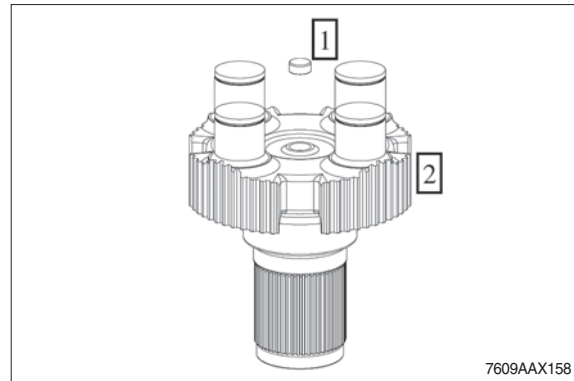

7609AAX158

- ⑮ Insert the cylindrical roller bearing into the planetary gear – for this purpose press the cylindrical roller bearing through the packaging sleeve until the snap ring engages into the annular groove of the planetary gear.

※ Use packaging sleeve to facilitate assembly.

- 1 Cylindrical roller bearing
- 2 Packaging sleeve
- 3 Snap ring
- 4 Planetary gear

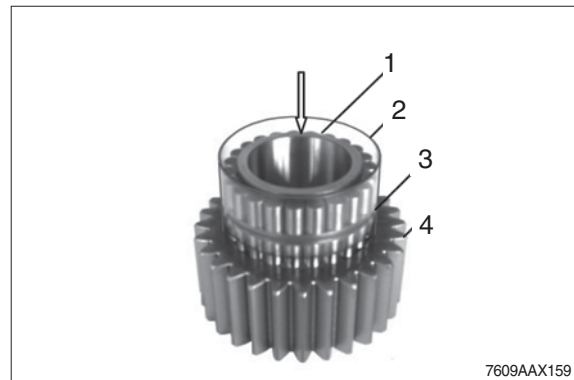

7609AAX159

- ⑯ Heat bearing inner rings and insert the premounted planetary gears with large radius facing the planetary carrier (downwards) until contact is obtained.

※ Adjust bearing inner rings after cooling down.

Then fix planetary gears by means of retaining rings.



7609AAX160

- ⑰ Heat tapered roller bearing and install it to the planetary carrier until contact is obtained.



7609AAX161

- ⑱ Wet front face (contact face bearing inner ring, arrow 1) and profile (teeth, arrow 2) in the output shaft with anti-corrosive agent.

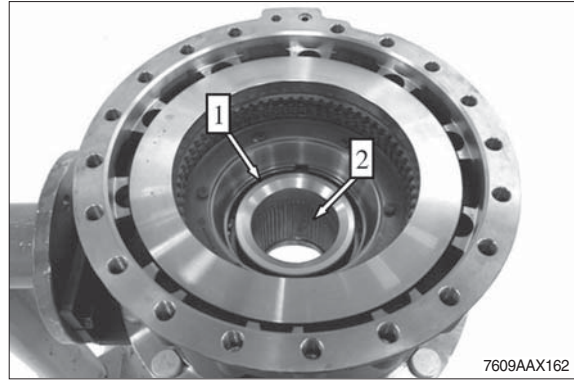

7609AAX162

- ⑲ Align disk package centrally and radially.  
Then insert the planetary carrier by means of the lifting device into the teeth of the output shaft.

Rear axle  
(planetary carrier with 3 planetary gears)  
Inner extractor 5870 300 019  
Eye bolt 5870 204 073

Front axle  
(planetary carrier with 4 planetary gears)  
Inner extractor 5870 300 017  
Eye nut 5870 204 076

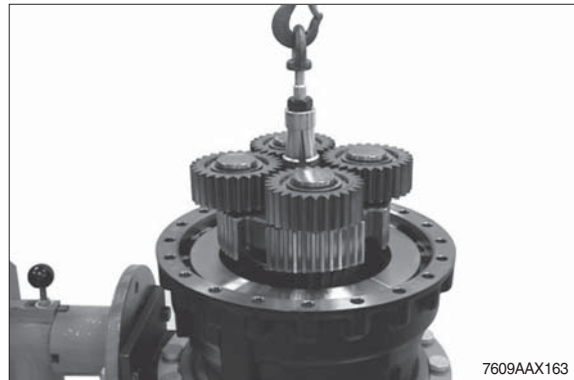

7609AAX163

### Setting of gap width output shaft / planetary carrier

- ⑳ Bring planetary carrier with measuring disk and three old locking screws, which were removed during disassembly, into contact position.

· Tightening torque :  
20.4 kgf · m (148 lbf · ft)

Measuring disk AA00 360 730

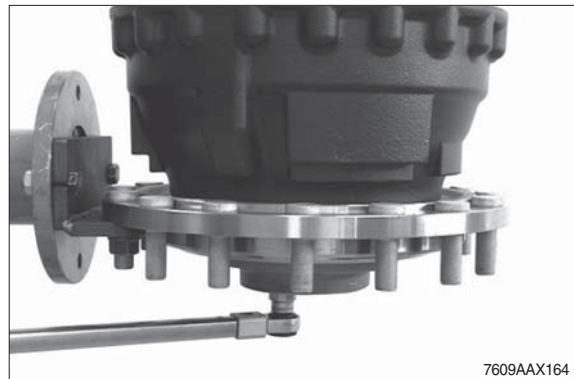

7609AAX164

- ㉑ Pivot output 180° and measure gap width from the output shaft to the planetary carrier (see also subsequent sketch).

Gap width e.g. .... 0.21 mm

Then remove the locking screws and the measuring disk again.

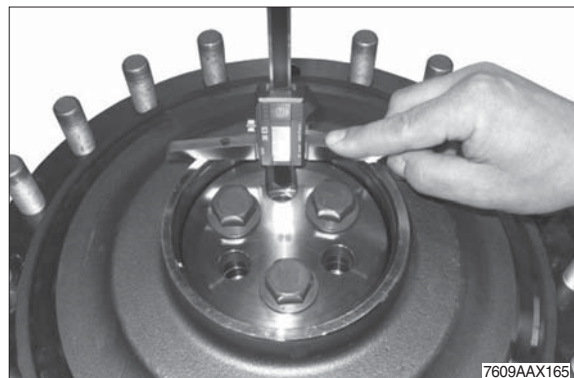

7609AAX165

- 1 Planetary carrier
- 2 Output shaft
- X Gap width

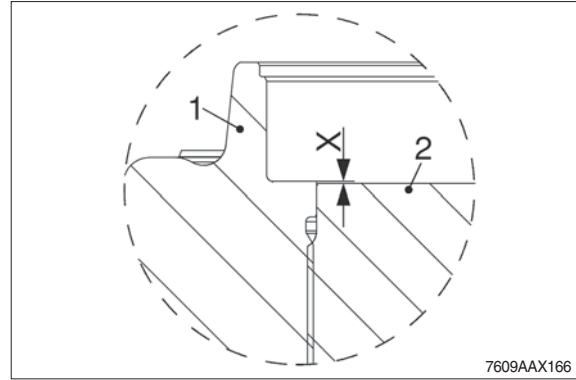

7609AAX166

② Select the cover (optional) on the basis of the following table.

Determined gap width (Delta)	Offset to be used on the cover	P/No.
0.30~0.24 mm	$0.13 \pm 0.01$ mm	ZGAQ-04137
0.239~0.18 mm	$0.07 \pm 0.01$ mm	ZGAQ-04370
0.179~0.10 mm	0.0 mm	ZGAQ-03909

※ Cover (ZGAQ-04370) has an offset of 0.07 mm on one side and an offset of 0.13 mm on the other side.

※ Offset 0.13 mm is visually marked with an annular groove (see arrow).

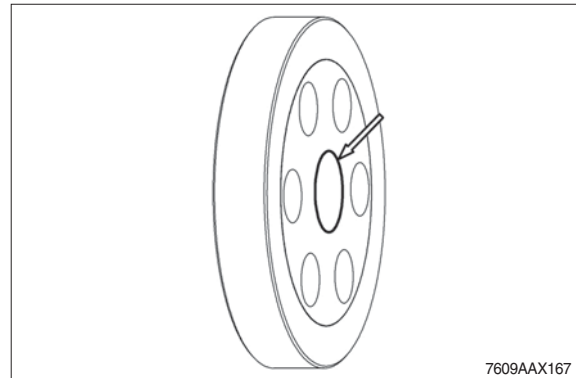

7609AAX167

③ Insert the cover with the offset e.g. 0.07 mm showing to the planetary carrier and tighten with **new** locking screws.

※ When using the cover with offset 0.07 mm, the groove (figure AX167) must be visible when the cover is installed.

※ Tighten locking screws successively with a tightening torque of 20.4 kgf · m (148 lbf · ft).

Then retighten the locking screws successively with a tightening torque of 51 kgf · m (369 lbf · ft).

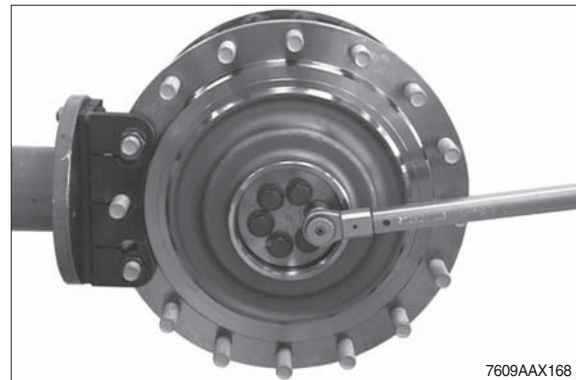

7609AAX168

④ Install O-ring (see arrow 1) to the cover.

Then wet contact face (arrow 2).

※ Use new cover and O-ring.



7609AAX169



- ②5 Insert the cover into the output shaft until contact is obtained.

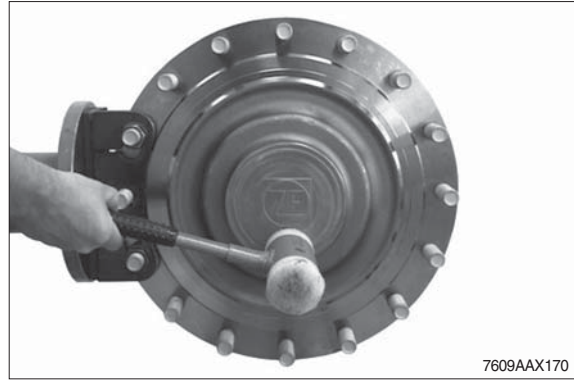

**Set the axial play of the sun gear shaft 0.5~2.0 mm**

- ②6 Determine dimension I, from the mounting face of the brake housing to the front face of the stop bolt.

Dimension I e.g. .... 19.75 mm

Gauge blocks                      5870 200 066  
 Straightedge                      5870 200 022

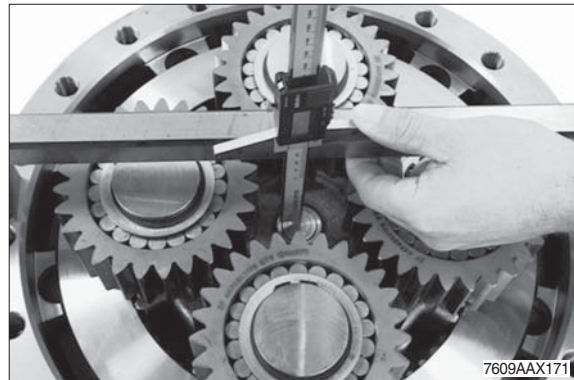

- ②7 Insert stub shaft into the teeth of the axle bevel gear until contact is obtained.

※ Pay attention to the installation position ;  
 mount the stub shaft with the long teeth showing to the differential.

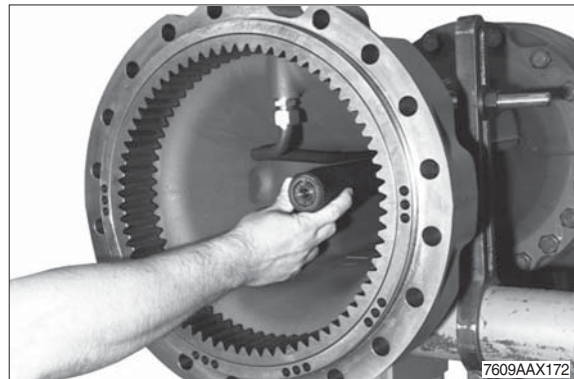

- ②8 Insert the sun gear shaft until contact is obtained.

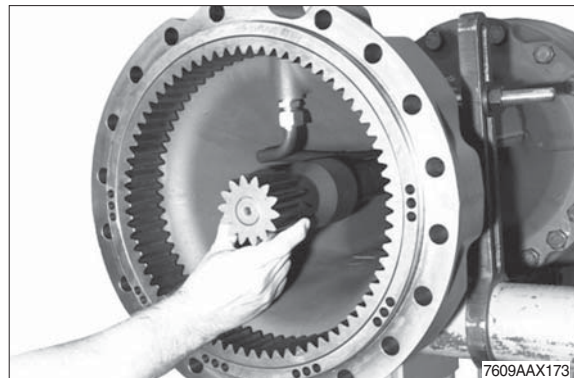

- ② Measure dimension II, from the front face of the sun gear shaft to the mounting surface of the axle housing.

Dimension II e.g. .... 17.15 mm

Straightedge 5870 200 022

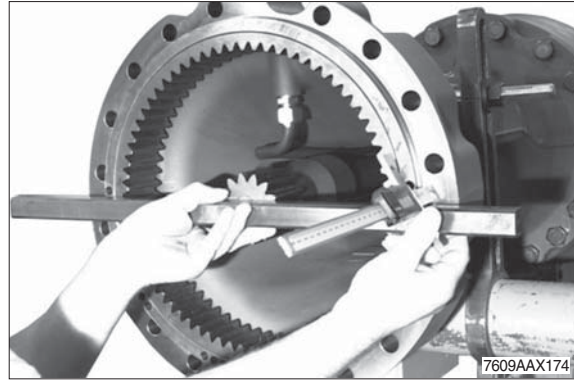

**CALCULATION EXAMPLE :**

Dimension I ..... 19.75 mm

Dimension II ..... - 17.15 mm

Difference ..... 2.60 mm

Required axial play e.g. .... - 1.00 mm

**Difference = shim e.g. s = 1.60 mm**

- ③ Insert sun gear shaft into the planetary carrier.

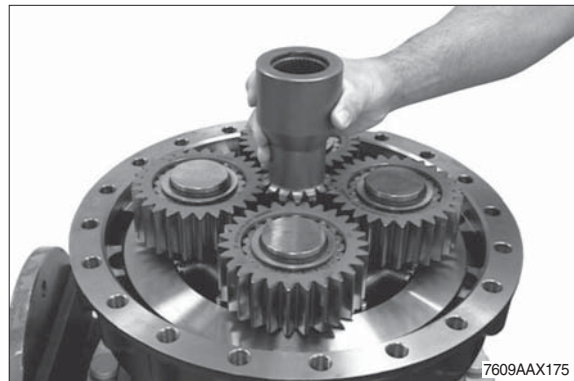

- ④ Fix determined shim (s) e.g. s = 1.60 mm with grease into the sun gear shaft.



- ③② Fix O-ring (see arrow) with grease into the countersink of the brake housing.

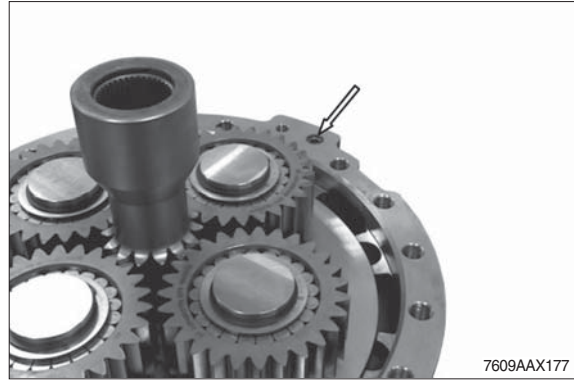

- ③③ Grease O-ring (see arrow) and install it to the axle housing.

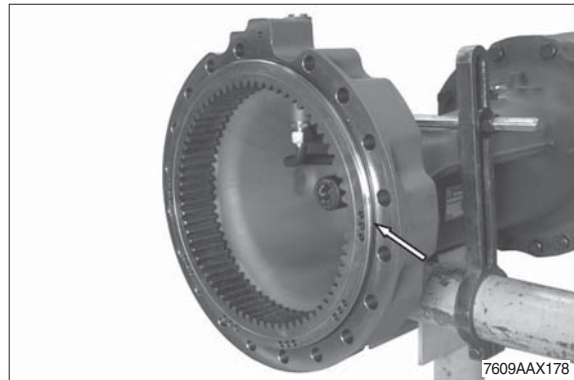

- ③④ Mount two adjusting screws and use the lifting device to bring the output into contact position with the axle housing.

Then fix the output by means of hexagon screws.

- Tightening torque (M18/10.9) :  
39.8 kgf · m (288 lbf · ft)

Adjusting screws (M18 × 15) 5870 204 029

Load carrying device 5870 281 043

- ※ Fix load carrying device with wheel stud.

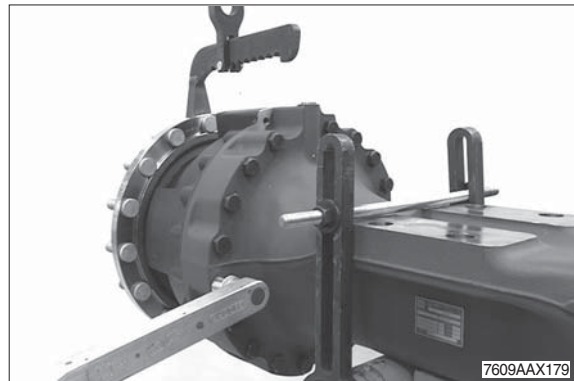

- ③⑤ Mount breather (see arrow).

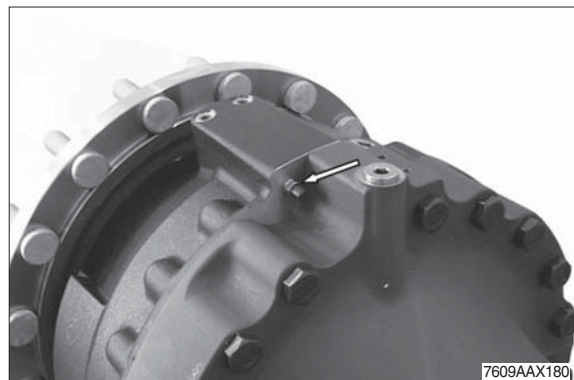

### Check brake hydraulics for leakages

- ※ Before starting the test, completely breathe the brake hydraulics.

Then pressurize the brake temporarily (5EA) with  $p = 100$  bar max.

### High-pressure test :

Build up test pressure  $p = 100-10$  bar max and close connection to HP pump via shut-off valve.

A pressure drop of max 2 % (2 bar) is permissible during a 5-minute testing time.

### Low-pressure test :

Reduce test pressure  $p = 5$  bar and close shut-off valve.

No pressure drop is allowed during a 5-minute testing time.

### Test media :

Engine oil SAE 10W

HP pump	5870 287 007
Clutch	0501 207 939
Reduction (M18 × 1.5)	5870 950 161
Oil collector bottle	5870 286 072

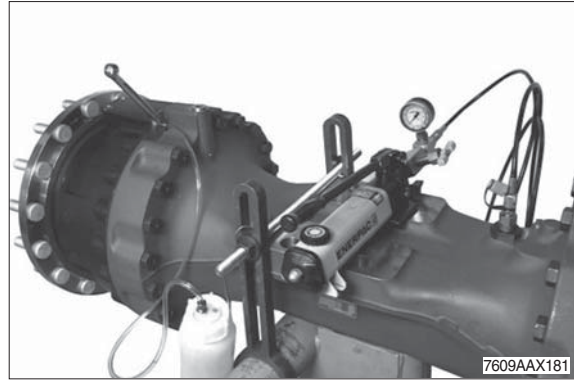

### Check operability of hydraulic lock differential (opt)

Build up pressure  $p = 20$  bar max and close connection to HP pump via shut-off valve.

### Lock on :

When rotating the input flange, both outputs must have the same direction of rotation.

### Lock off :

When rotating the input flange, one side has no movement or has the opposite direction of rotation.

Prior to putting the axle into operation, fill it with oil according to the related lubrication and maintenance instructions.

