

SECTION 6 WORK EQUIPMENT

Group 1 Structure and Function	6-1
Group 2 Operational Checks and Troubleshooting	6-30
Group 3 Tests and Adjustments	6-41
Group 4 Disassembly and Assembly	6-54

SECTION 6 WORK EQUIPMENT

GROUP 1 STRUCTURE AND FUNCTION

1. HYDRAULIC SYSTEM OUTLINE

The loader hydraulic system is a pilot operated, closed center system which is supplied with flow from the variable displacement piston main hydraulic pump.

The loader system components are :

- Loader pump
- Main control valve
- Bucket cylinder
- Boom cylinders
- Remote control valve (Pilot control valve)
- Safety valve

Flow from the steering pump not used by the steering system leaves the flow amplifier EF port. It flows to the inlet port plate of two section or three section block type main control valve.

The main control valve is load pressure independent flow distribution system which routes flow to the boom, bucket or auxiliary cylinders (not shown) when the respective spools are shifted.

Flow from the loader pump is routed to the main control valve where pump outlet pressure is reduced to pilot circuit pressure. The main control valve flow to the remote control valve.

The remote control valve routed flow to either end of each spool valve section in the main control valve to control spool stroke.

A accumulator mounted on safety valve supplies a secondary pressure source to operated remote control valve so the boom can be lowered if the engine is off.

The return circuit for the main hydraulic system have return filter inside the hydraulic tank. The return filter uses a filter element and a bypass valve. The bypass valve is located in the upside of filter.

2. HYDRAULIC CIRCUIT (-#0182)

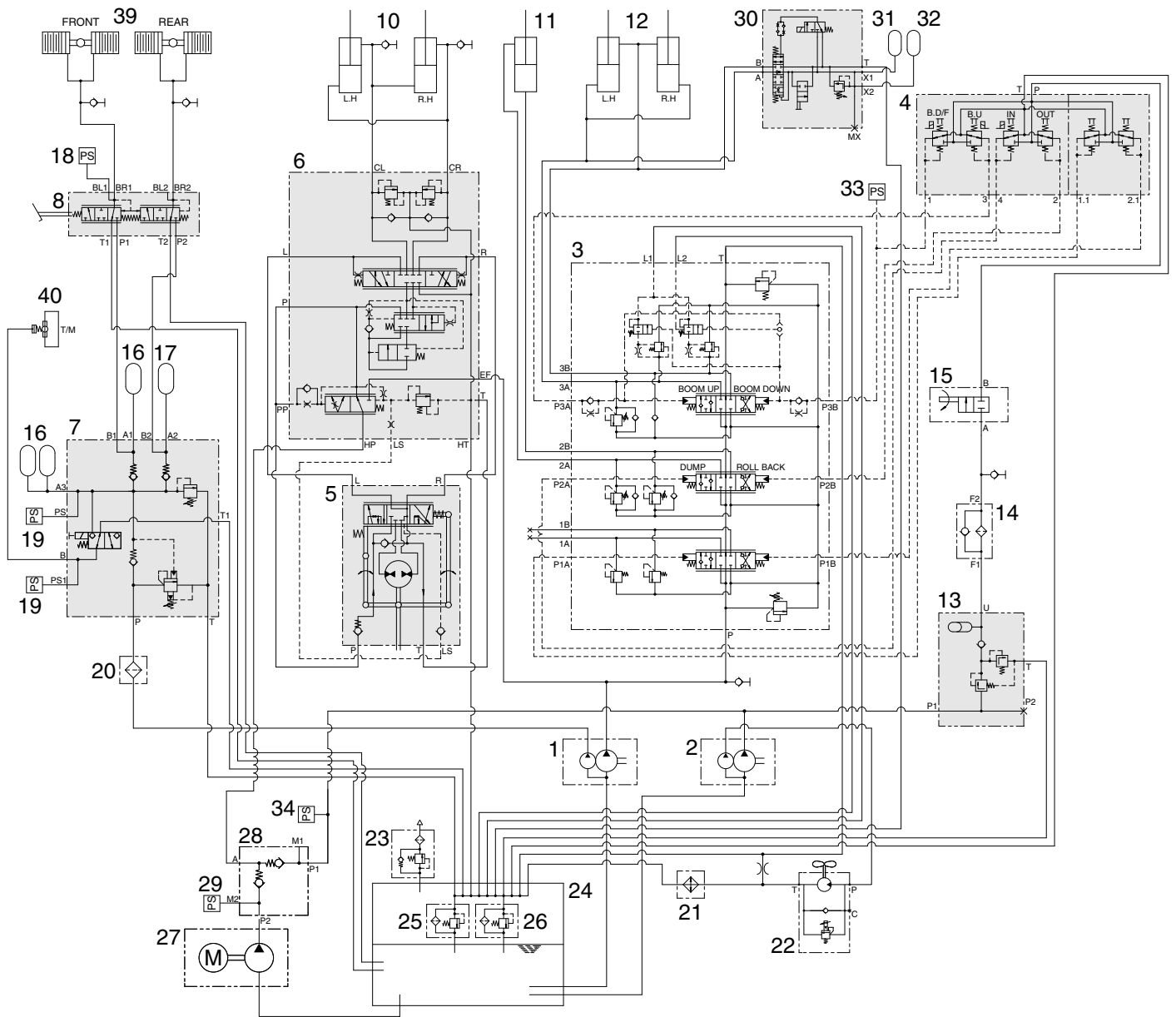

7809S6WE01

- | | | | | | |
|----|----------------------|----|-----------------|----|--------------------------|
| 1 | Main pump (+brake) | 14 | Line filter | 26 | Bypass valve |
| 2 | Steering & fan pump | 15 | Safety valve | 27 | Pump motor (opt) |
| 3 | Main control valve | 16 | Accumulator | 28 | Check valve block (opt) |
| 4 | Remote control valve | 17 | Accumulator | 29 | Pressure sensor (opt) |
| 5 | Steering unit | 18 | Pressure sensor | 30 | Ride control valve (opt) |
| 6 | Flow amplifier | 19 | Pressure sensor | 31 | Accumulator (opt) |
| 7 | Cut-off valve | 20 | Line filter | 32 | Accumulator (opt) |
| 8 | Brake valve | 21 | Oil cooler | 33 | Pressure sensor (opt) |
| 10 | Steering cylinder | 22 | Fan motor | 34 | Pressure sensor |
| 11 | Bucket cylinder | 23 | Air breather | 39 | Axle |
| 12 | Boom cylinder | 24 | Hydraulic tank | 40 | Parking brake at T/M |
| 13 | Pilot supply unit | 25 | Return filter | | |

HYDRAULIC CIRCUIT (#0183~)

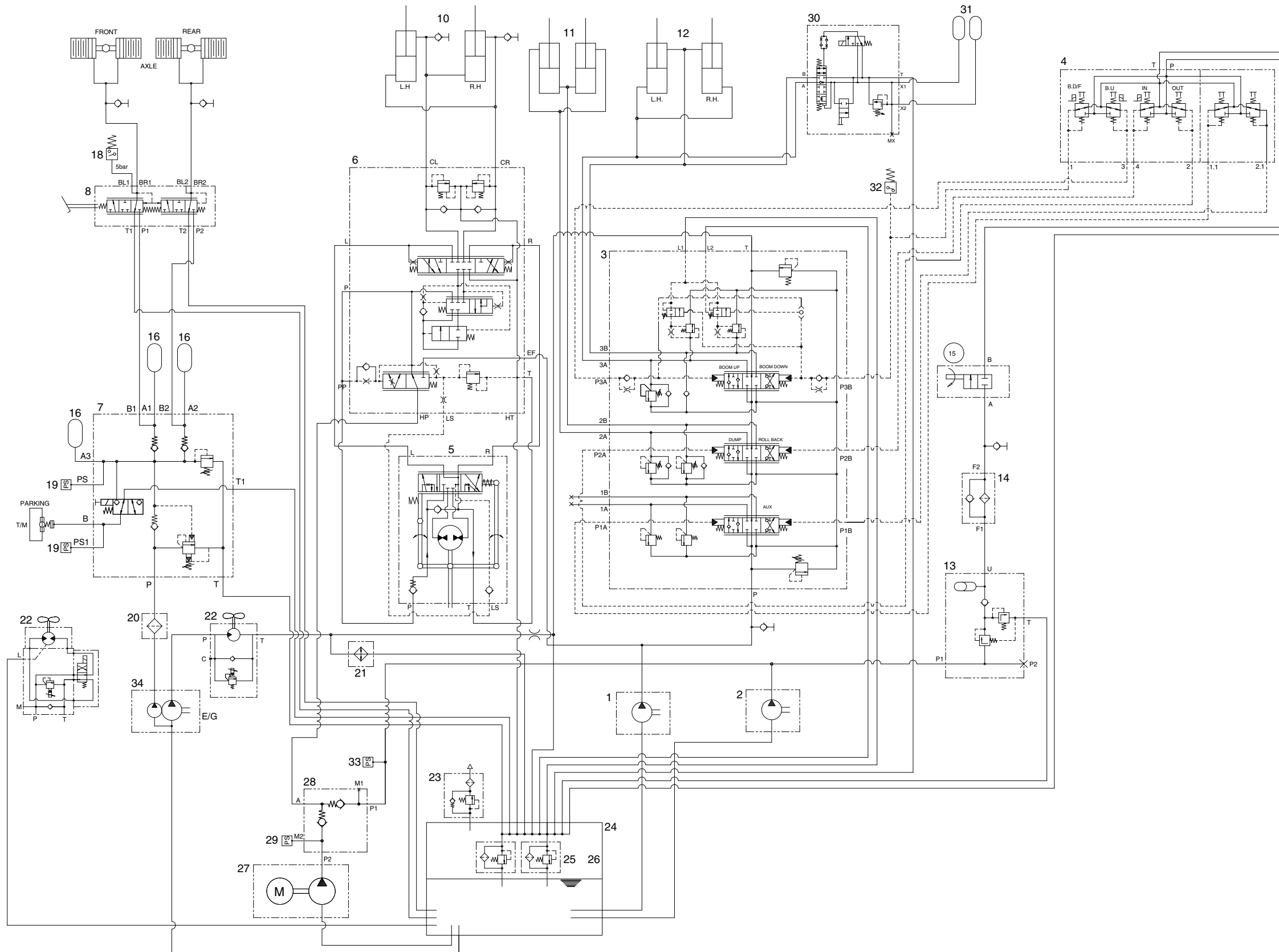

- 1 Main pump
- 2 Steering pump
- 3 Main control valve
- 4 Remote control valve
- 5 Steering unit
- 6 Flow amplifier
- 7 Cut-off valve
- 8 Brake valve
- 10 Steering cylinder
- 11 Bucket cylinder
- 12 Boom cylinder
- 13 Pilot supply unit
- 14 Line filter
- 15 Safety valve
- 16 Accumulator
- 18 Pressure switch
- 19 Pressure sensor
- 20 Line filter
- 21 Oil cooler
- 22 Fan motor
- 23 Air breather
- 24 Hydraulic tank
- 25 Return filter
- 26 Bypass valve
- 27 Motor pump (opt)
- 28 Check valve (opt)
- 29 Pressure sensor (opt)
- 30 Ride control valve (opt)
- 31 Accumulator (opt)
- 32 Pressure switch (opt)
- 33 Pressure sensor
- 34 Fan and brake pump

7809S6WE01A

3. WORK EQUIPMENT HYDRAULIC CIRCUIT

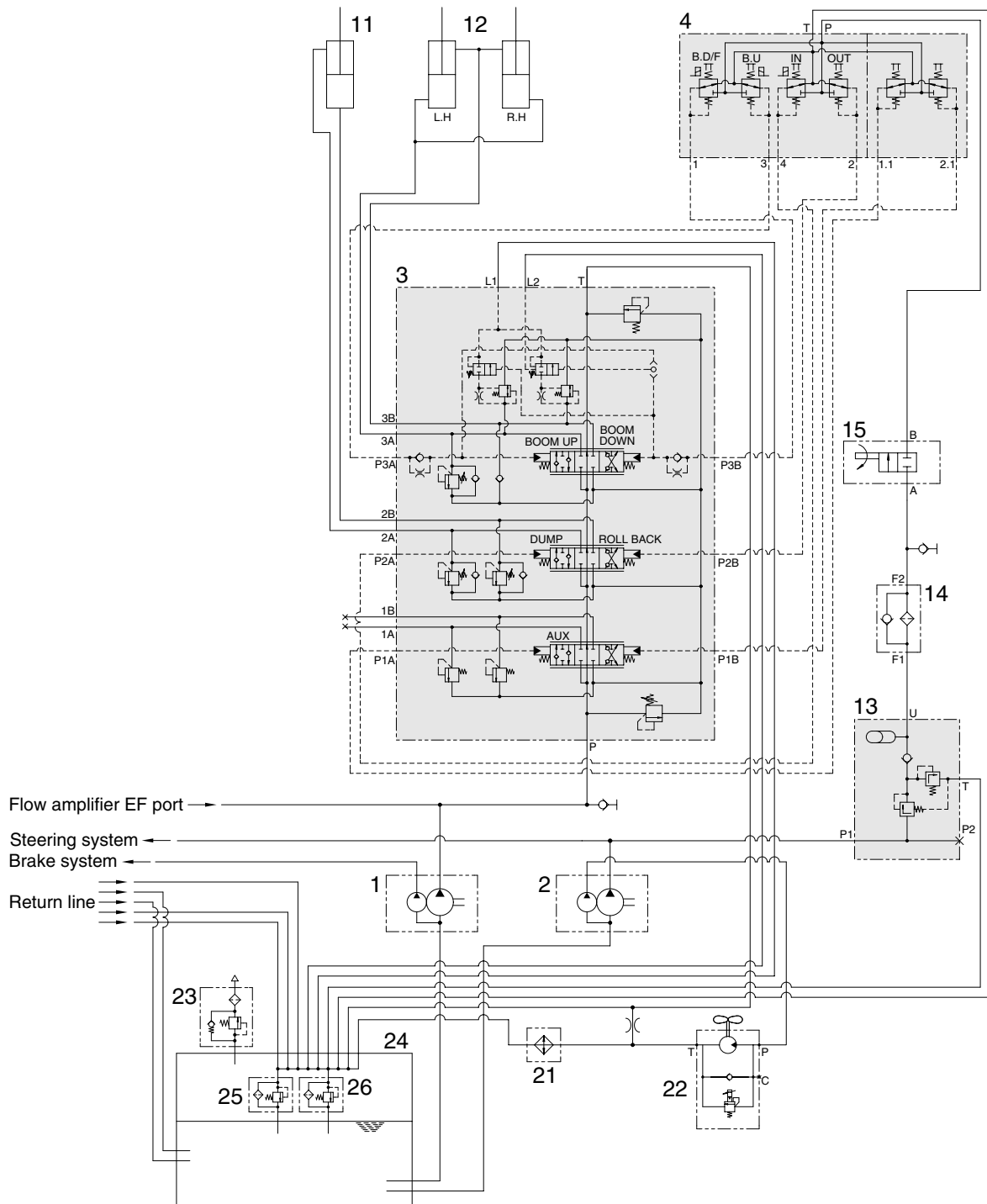

7809S6WE02

- | | | | | | |
|----|----------------------|----|-------------------|----|----------------|
| 1 | Main pump (+brake) | 12 | Boom cylinder | 23 | Air breather |
| 2 | Steering & fan pump | 13 | Pilot supply unit | 24 | Hydraulic tank |
| 3 | Main control valve | 15 | Safety valve | 25 | Return filter |
| 4 | Remote control valve | 21 | Oil cooler | 26 | Bypass valve |
| 11 | Bucket cylinder | 22 | Fan motor | | |

1) WHEN THE RCV LEVER IS IN THE RAISE POSITION

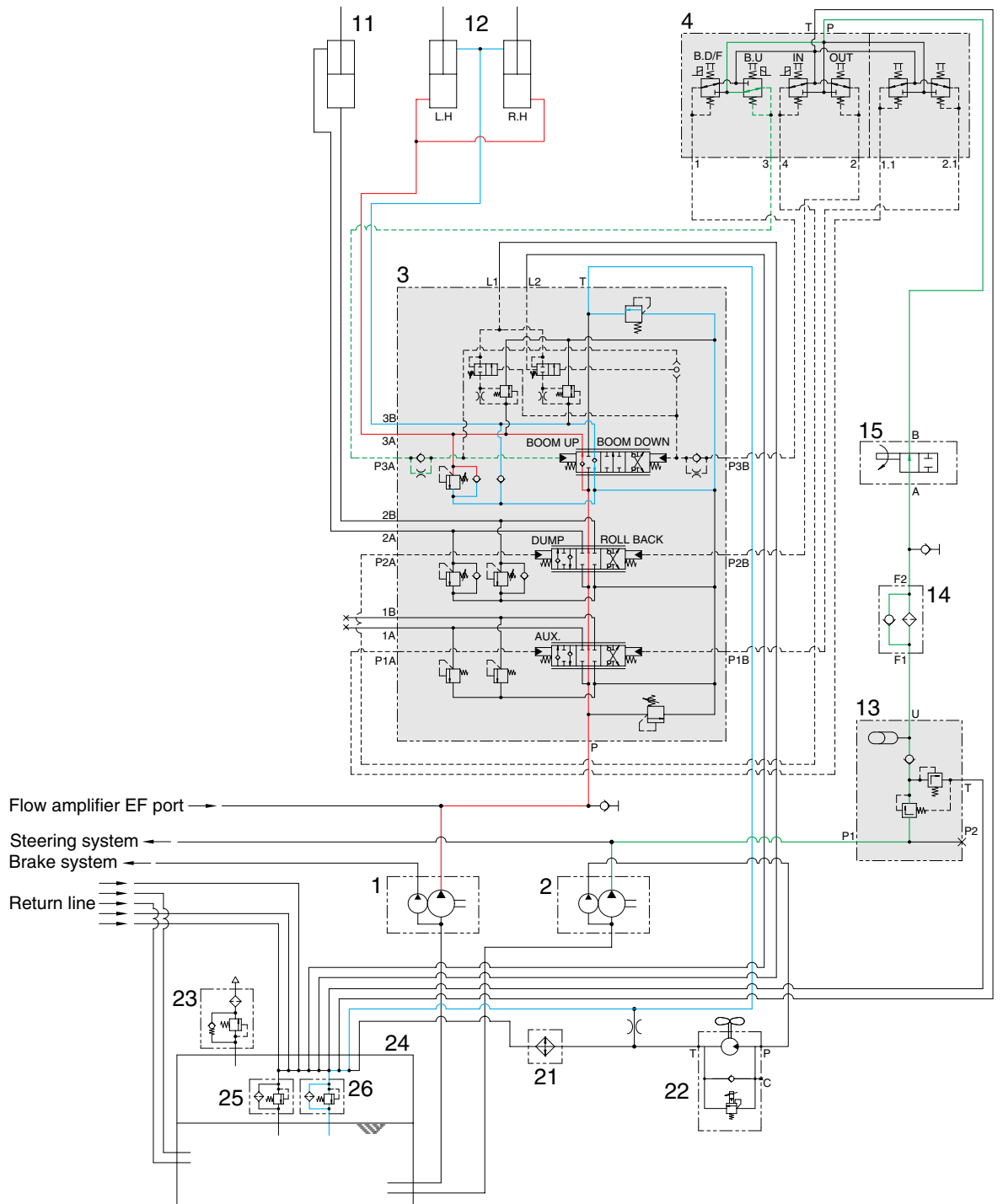

7809S6WE03

- When the RCV lever (4) is pulled back, the boom spool is moved to raise position by pilot oil pressure from port 3 of RCV.
- The oil from main pump (1) flows into main control valve (3) and then goes to the large chamber of boom cylinder (12) by pushing the load check valve of the boom spool through center bypass circuit of the bucket spool.
- The oil from the small chamber of boom cylinder (12) returns to hydraulic oil tank (24) through the boom spool at the same time.
- When this happens, the boom goes up.

2) WHEN THE RCV LEVER IS IN THE LOWER POSITION

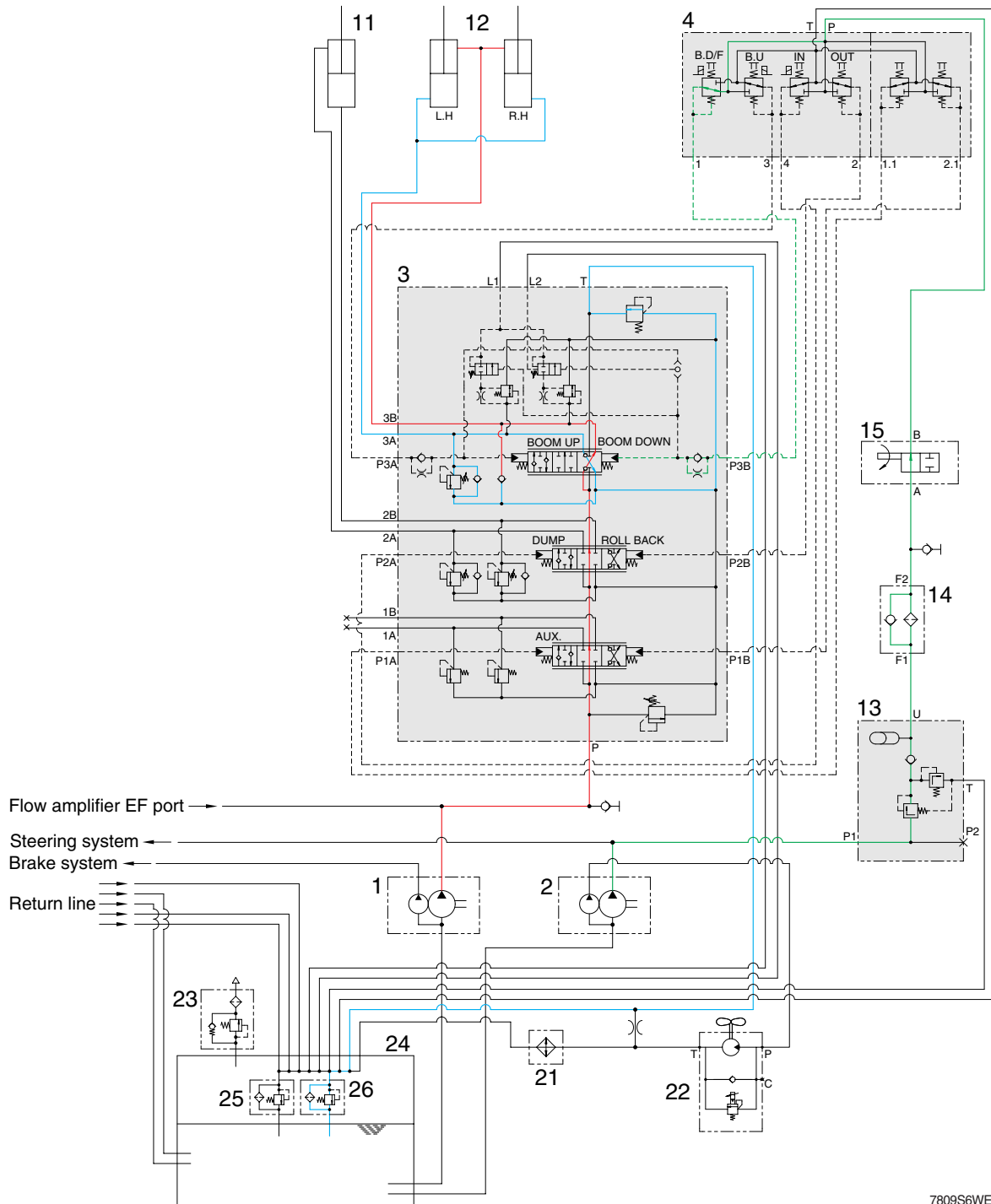

7809S6WE04

- When the RCV lever (4) is pushed forward, the boom spool is moved to lower position by pilot pressure from port 1 of RCV.
- The oil from main pump (1) flows into main control valve and then goes to small chamber of boom cylinder (12) by pushing the load check valve of the boom spool through center bypass circuit of the bucket spool.
- The oil returned from large chamber of boom cylinder (12) returns to hydraulic tank (24) through the boom spool at the same time.
- When the lowering speed of boom is faster, the return oil from the large chamber of boom cylinder combines with the oil from the pump, and flows into the small chamber of the cylinder. This prevents cylinder cavitation by the negative pressure when the pump flow cannot match the boom down speed.

3) WHEN THE RCV LEVER IS IN THE FLOAT POSITION

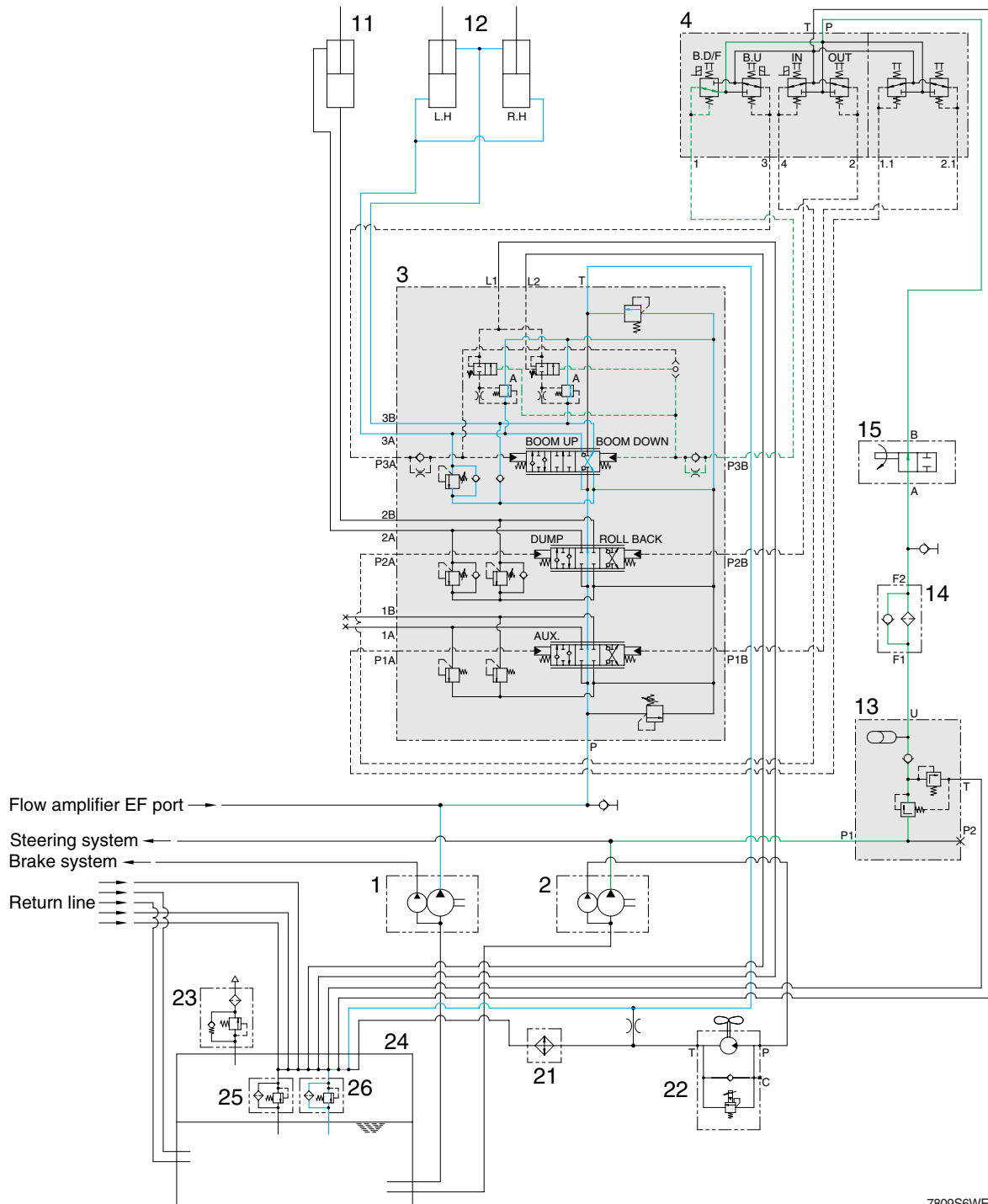

7809S6WE05

Float is achieved by opening 2 large capacity check valves (A) fitted into the bolt on float check block. These check valves connect each of the boom service ports (3A, 3B) to the tank gallery. Opening of these valves is controlled by pilot pressure from the hydraulic pilot control valve (4). As the hydraulic control lever is selected in the power down direction the pressure at the spool pilot end can on the main valve increases and at some point the spool starts to move progressively through its stroke. This pilot pressure is also connected, internally within the valve, onto a separate pilot spool which controls the opening and closing of the pilot check valves (A). As the pilot pressure operates the main spool up to its maximum stroke the pilot spool then selects at some pressure beyond that and the check valves open, operating a separate connection between the large chamber and small chamber ports L and tank.

Subsequent deselection of the control lever allows the pilot spool to deselect, the check valves close, followed by the main spool returning to neutral, all with minimal hysteresis.

On a four position spool, when selecting the spool in one direction, it has to control both power down and float. This means that the spool stroke for the power down part of the stroke is limited and so the metering length is shortened, giving limited control on the service.

Because float is achieved by separate check valves, the whole of the spool selection in that direction can be used for power down and so the metering performance can be maximized.

Because the float is achieved by opening two large capacity check valves, the ability of the valve to 'make up' any cavitation during power down is greatly improved over that of a standard 4 position spool. The original benchmark of no dead time(cavitation in the boom cylinder small chamber) while floating down from full lift height at mid engine speed, has been surpassed. The achievement that has been measured with this product is that there is less than 1 second dead time when floating down from full height at low idle.

4) WHEN THE RCV LEVER IS IN THE DUMP POSITION

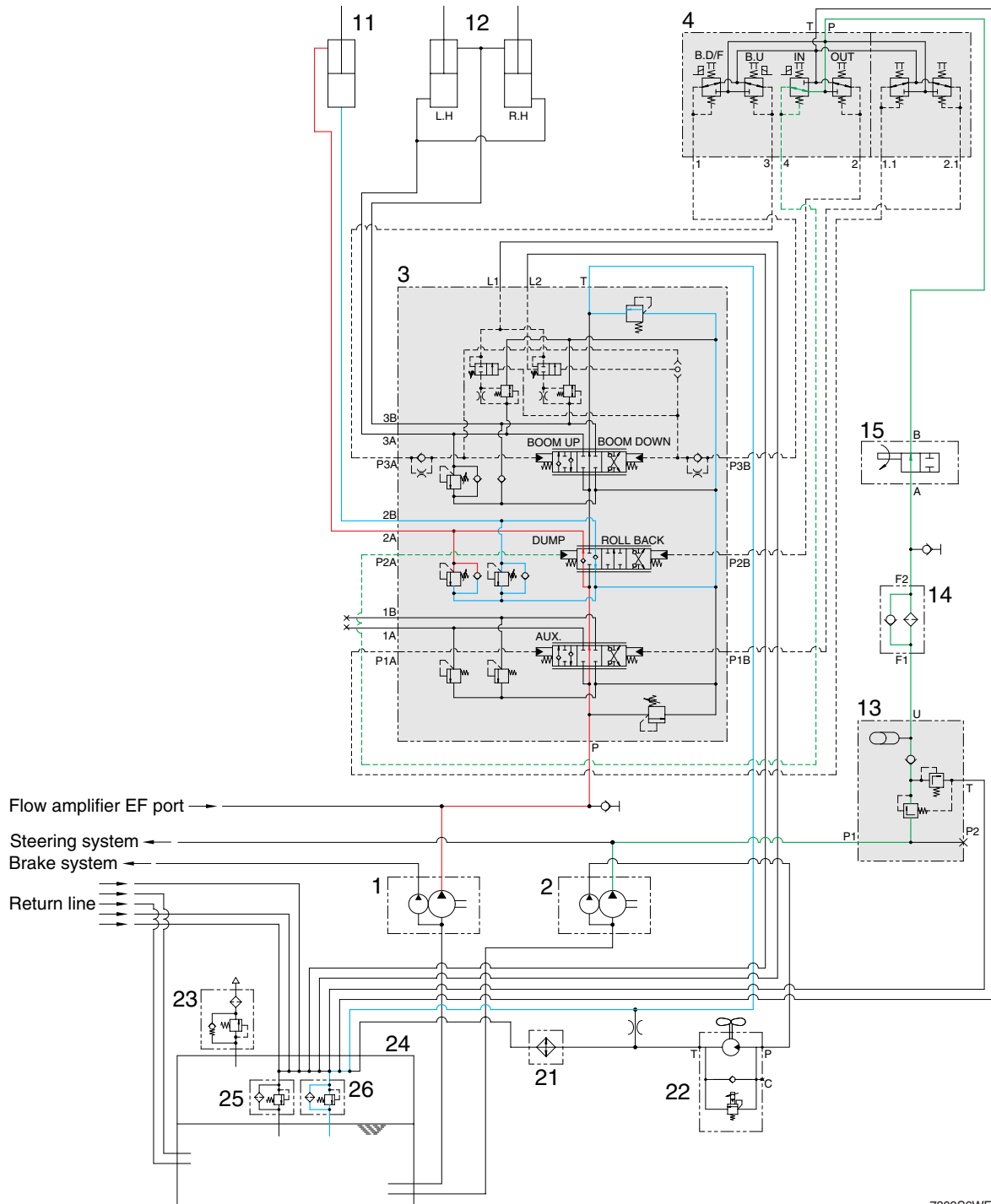

7809S6WE06

- If the RCV lever (4) is pushed right, the bucket spool is moved to dump position by pilot oil pressure from port 2 of RCV.
- The oil from main pump (1) flows into main control valve (3) and then goes to the small chamber of bucket cylinder (11) by pushing the load check valve of the bucket spool.
- The oil at the large chamber of bucket cylinder (11) returns to hydraulic tank (24) through the bucket spool.
- When this happens, the bucket is dumped.
- When the dumping speed of bucket is faster, the oil returned from the large chamber of bucket cylinder combines with the oil from the pump, and flows into the small chamber of the cylinder. This prevents cylinder cavitation by the negative pressure when the pump flow cannot match the bucket dump speed.

5) WHEN THE RCV LEVER IS IN THE ROLL BACK (retract) POSITION

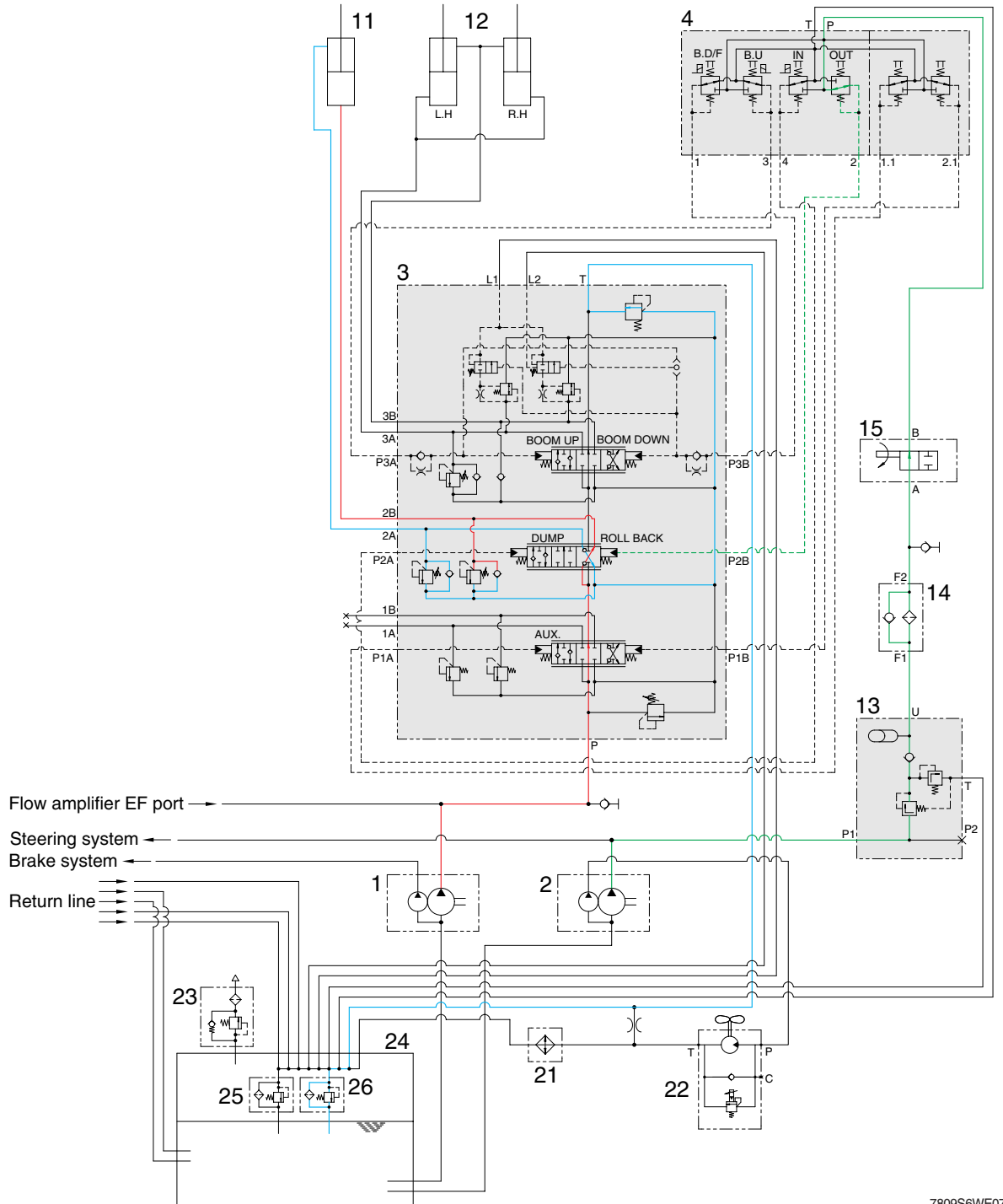

7809S6WE07

- If the RCV lever (4) is pulled left, the bucket spool is moved to roll back position by pilot oil pressure from port 4 of RCV.
- The oil from main pump (1) flows into main control valve (3) and then goes to the large chamber of bucket cylinder by pushing the load check valve of the bucket spool.
- The oil at the chamber of bucket cylinder (11) returns to hydraulic tank (24) through the bucket spool.
- When this happens, the bucket roll back.
- When the rolling speed of bucket is faster, the return oil from the small chamber of bucket cylinder combines with the oil from the pump, and flows into the large chamber of the cylinder. This prevents cylinder cavitation by the negative pressure when the pump flow cannot match the bucket rolling speed.

4. MAIN PUMP (+BRAKE PUMP) : ~#0182

1) STRUCTURE (1/2)

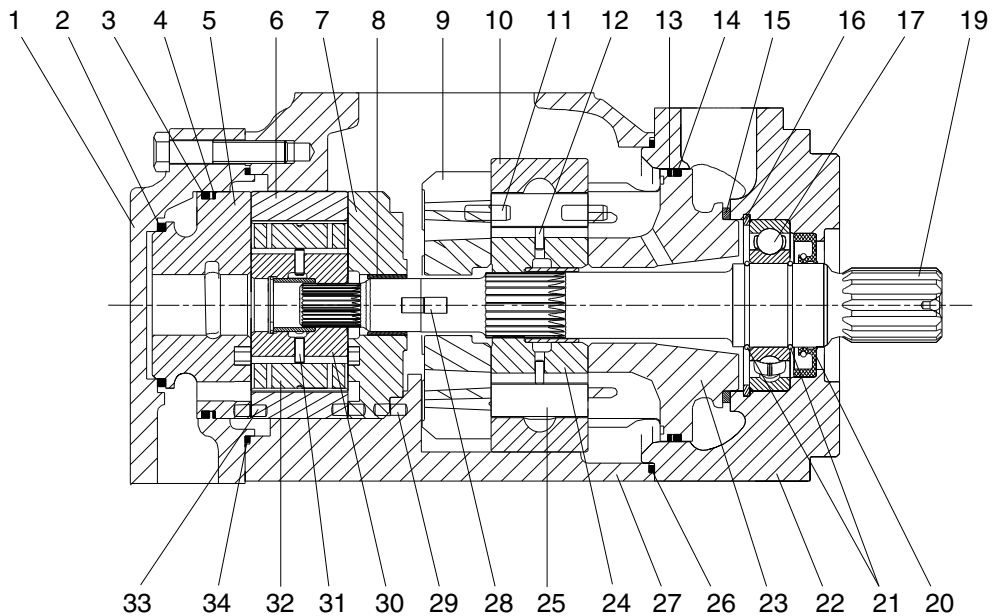
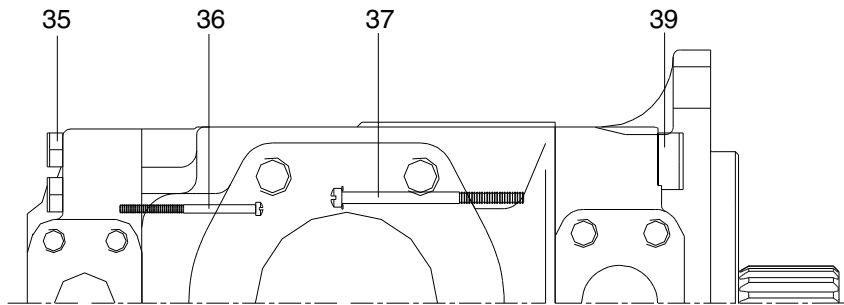

7807AWE09

- | | | | | | |
|----|---------------------|----|---------------------|----|------------------|
| 1 | End cap | 14 | Section seal | 28 | Dowel pin |
| 2 | Section seal | 15 | Section seal | 29 | Dowel pin |
| 3 | Section seal | 16 | Retaining ring | 30 | Rotor assembly |
| 4 | Back up ring | 17 | Ball bearing | 31 | Vane holdout pin |
| 5 | Pressure port plate | 19 | Shaft | 32 | Vane |
| 6 | Camring | 20 | Shaft seal | 33 | Dowel pin |
| 7 | Rear port plate | 21 | Round section ring | 34 | Section seal |
| 8 | Bushing | 22 | Mounting cap | 35 | Screw |
| 9 | Rear port plate | 23 | Pressure port plate | 36 | Screw |
| 10 | Camring | 24 | Rotor assembly | 37 | Screw |
| 11 | Dowel pin | 25 | Vane | 39 | Screw |
| 12 | Vane holdout pin | 26 | Section seal | | |
| 13 | Back up ring | 27 | Housing | | |

2) DESCRIPTION

The main vane pump consist of six basic components : end cap (2), **P2** section unitized cartridge (4) consisting of ; rotor, vanes, vane holdout pins, cam ring, port plate, and pressure plate, center housing (5), **P1** section unitized cartridge (6) consisting of ; rotor, vanes, vane holdout pins, cam ring, port plate, pressure plate, shaft (11) and bearing and mounting cap (14).

The main vane pump features the use of unitized pumping cartridge for both the **P1** and **P2** pump section.

The unitized cartridge assemblies are pretested and provide for ease of disassembly and assembly in the event it becomes necessary or desirable to make repairs, overhaul or revise the flow delivery.

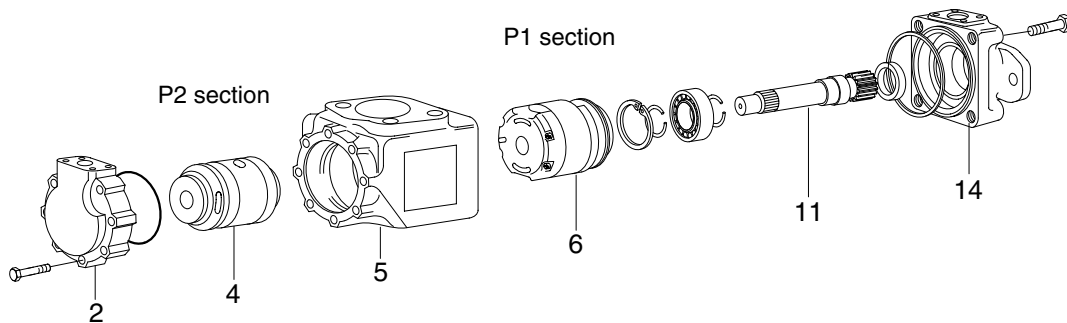

7707WE10

3) OPERATION

The pumping operation of this unit(each cartridge) is obtained by providing a fixed interior cam surface and a rotating inner member(rotor) containing vanes which held in contact with the inner cam surface. As the rotor is rotated by the drive shaft, the vanes are urged outward against the outward sloping cam surface, forming a cavity at the inlet ports of the port plates. Atmospheric pressure and suction created by the expanding cavity between the rotating vanes fill the inlet cavity with fluid. As the rotation continues and the vanes that had previously moved outward and now have fluid trapped between them and the port plates, follow the inward slope of the cam which decreases the cavity containing the trapped fluid and discharges the fluid at system pressure through the pressure port openings in the port plates.

The rotating portion of the unitized cartridges feature the use of pressure actuated vanes which are urged against the cam ring by pins located in the bottom of each rotor vane slot. Initial force to bring the vanes in contact with the cam ring contour during start up is provided by centrifugal force. When pumping operation starts and pressure is established, fluid under pressure fills the pin cavity through the feed holes.

The feed holes open to the pressure port twice every revolution. All other times they are closed off by the port plate. This pressure under the pin provides the force necessary to keep the vanes in contact with the cam contour.

- ※ When operating the pump at the maximum outlet pressure, the pump shaft rotation should not be allowed to fall below 600rpm in order to maintain proper vane to cam ring contact. The inlet or suction flow for both the **P1** cartridge and **P2** cartridge feeds through a common 3 port in the center housing, through the large ports of each port plate for each cartridge and through the center hole in the suction zone of each cam ring.

MAIN PUMP : #0183~

1) STRUCTURE

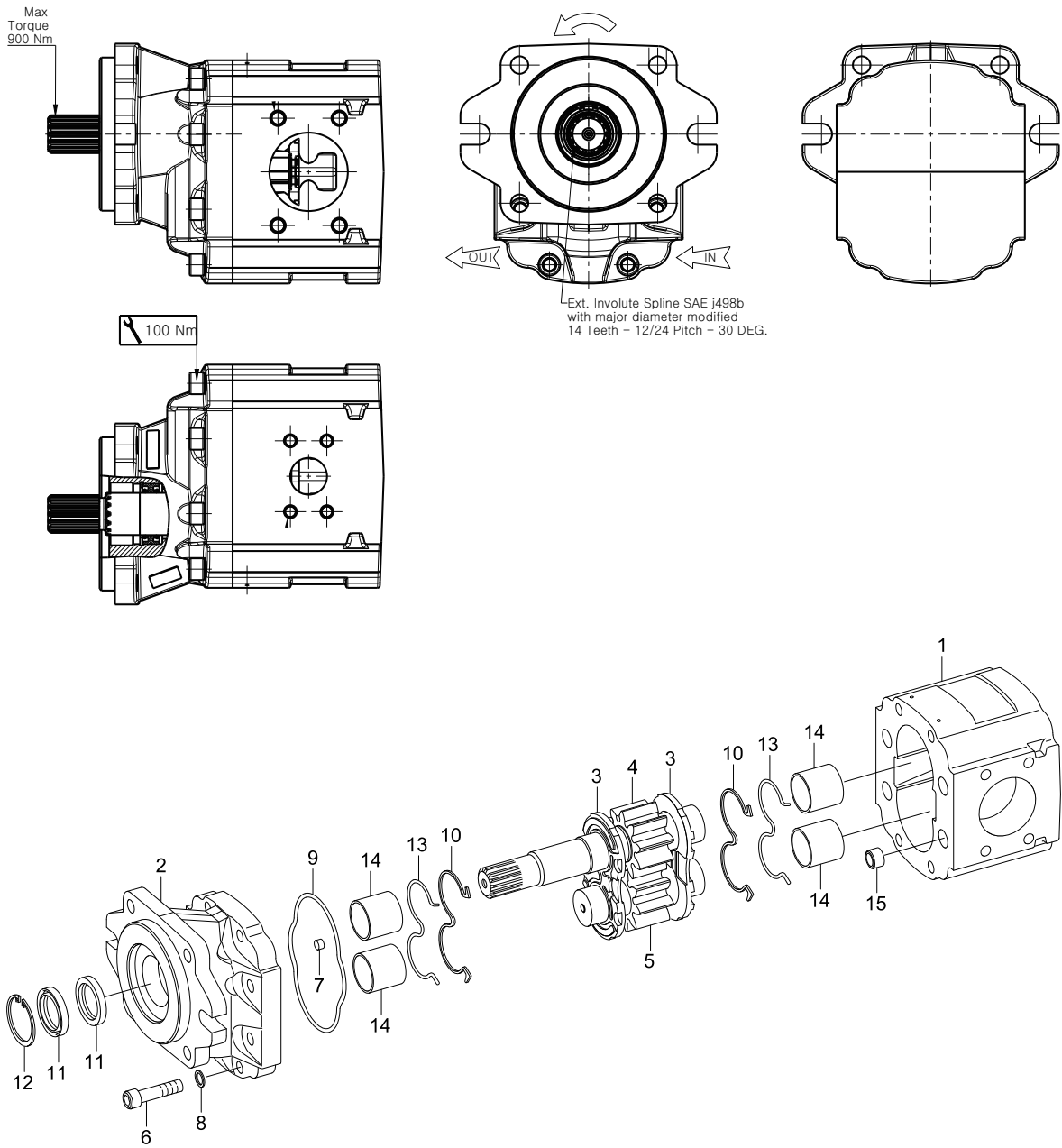

7809SWE50

- | | | | | | |
|---|--------------|----|--------|----|----------------|
| 1 | Gear housing | 6 | Screw | 11 | Shaft seal |
| 2 | Front cover | 7 | Screw | 12 | Ring |
| 3 | Thrust plate | 8 | Washer | 13 | Back up ring |
| 4 | Drive shaft | 9 | O-ring | 14 | Sleeve bearing |
| 5 | Driven gear | 10 | Seal | 15 | Steel bushing |

5. REMOTE CONTROL VALVE

1) STRUCTURE

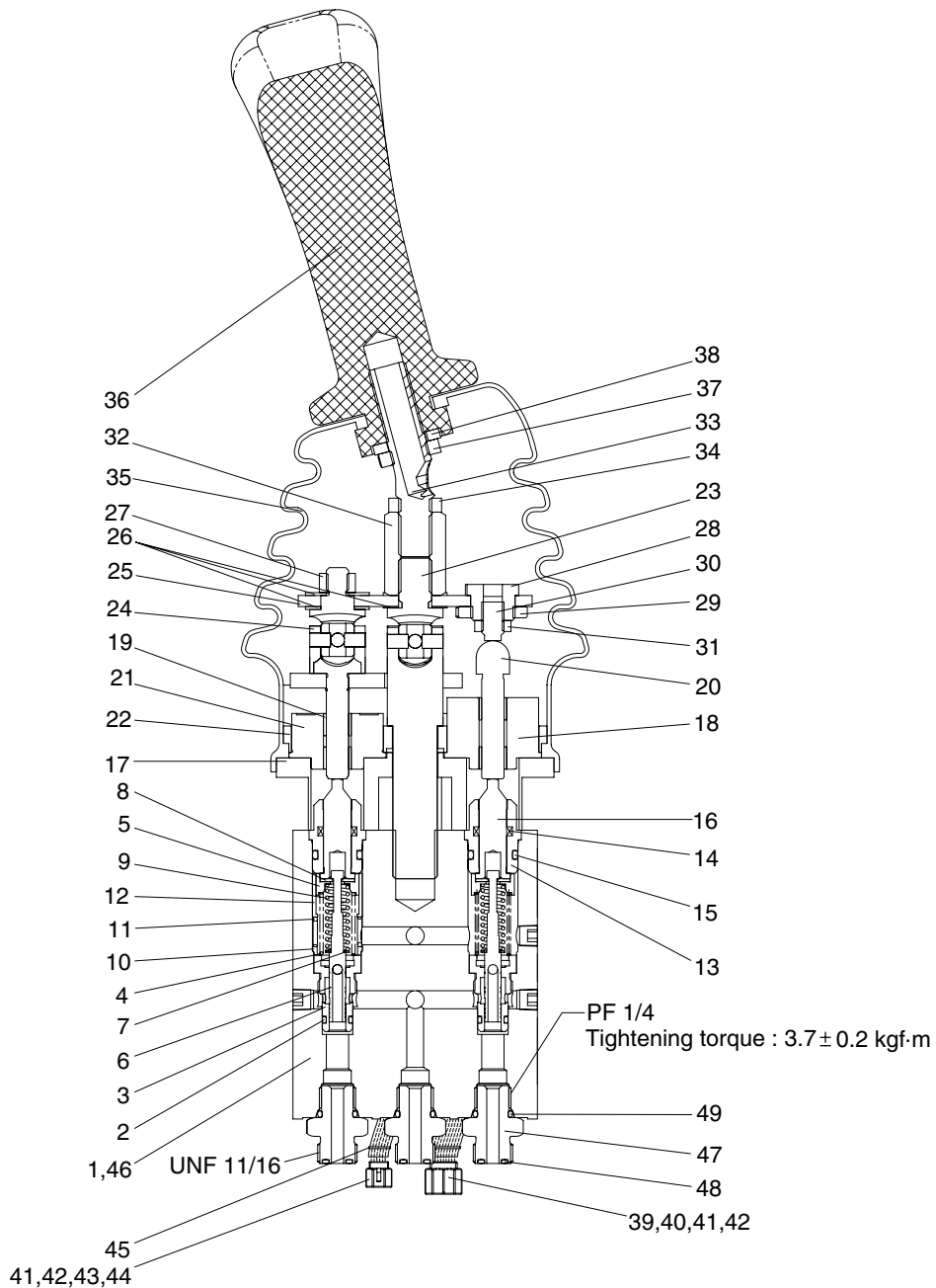

1	Body	14	Rod seal	27	Nut	40	Rear holder
2	O-ring	15	O-ring	28	Plug	41	Terminal
3	Plug	16	Push rod	29	Nut	42	Seal wire
4	Spring	17	Plate	30	Set screw	43	Housing
5	Spring seat	18	Rod stopper	31	Nut	44	Rear holder
6	Spool	19	Bushing	32	Nut	45	Clip band
7	Spring seat	20	Rod	33	Handle bar	46	Plug
8	Stopper	21	Magnet	34	Nut	47	Connector
9	Spring	22	Plate	35	Boot	48	O-ring
10	Spring seat	23	Joint assy	36	Handle assy	49	O-ring
11	Spring	24	Joint assy	37	Nut		
12	Spring seat	25	Plate	38	Spring washer		
13	Plug	26	Washer	39	Housing		

7809S6WE28

2) OPERATION

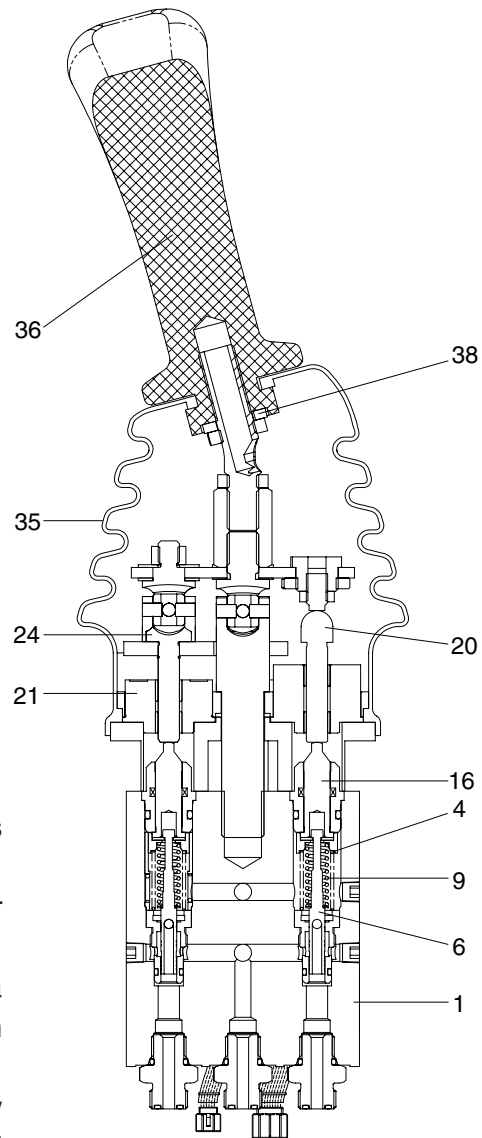
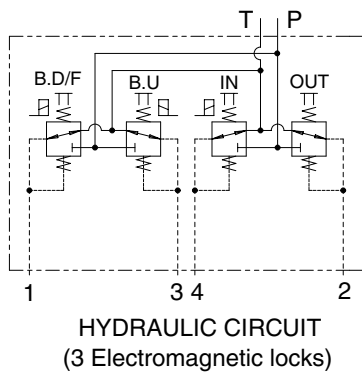

7407S6WE27

(1) Hydraulic functional principle

Pilot devices with end position locks operate as direct operated pressure reducing valves.

They basically comprise of handle (36), four pressure reducing valves, body (1) and locks.

Each pressure reducing valve comprises of a control spool (6), a control spring (9), a return spring (4), push rod (16) and rod (20).

At rest, handle (36) is held in its neutral position by return springs (4). Ports (1, 2, 3, 4) are connected to tank port T via drilling.

When handle (36) is deflected, rod (20) is pressed against return spring (4) and control spring (9). Control spring (9) initially moves control spool (6) downwards and closes the connection between the relevant port and tank port T. At the same time the relevant port is connected to port P via drilling. The control phase starts as soon as control spool (6) finds its balance between the force from control spring (9) and the force, which results from the hydraulic pressure in the relevant port (ports 1, 2, 3 or 4).

Due to the interaction between control spool (6) and control spring (9) the pressure in the relevant port is proportional to the stroke of rod (20) and hence to the position of handle (36).

This pressure control which is dependent on the position of the handle (36) and the characteristics of the control spring permits the proportional hydraulic control of the main directional valves and high response valves for hydraulic pumps.

A rubber boot (35) protects the mechanical components in the housing from contamination.

(2) End position lock

Only those control ports, for which it is necessary to hold the handle in a deflected position are equipped with end position locks.

Electromagnetic lock

When this threshold is overcome, a joint assy (24) contacts the magnet (21); if the magnet (21) is energized, then handle (36) is held in its end position by magnetic force.

This lock is released automatically when the solenoid is deenergized.

6. MAIN CONTROL VALVE

1) STRUCTURE

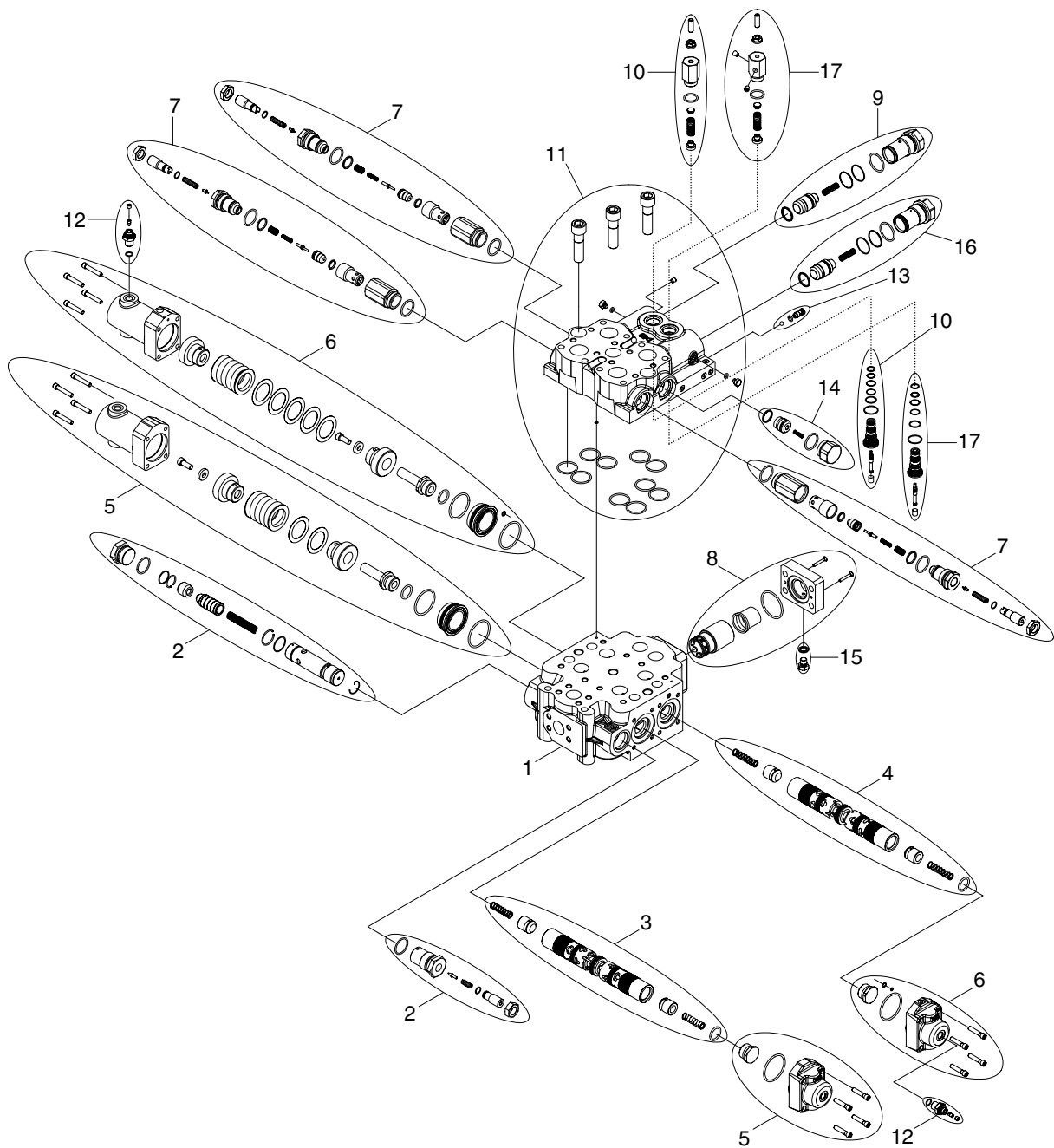

7707WE30

- | | | | |
|---|--|----|---|
| 1 | Housing group | 10 | Pilot valve assembly |
| 2 | Main relief valve assembly | 11 | Pilot operated float check block assembly |
| 3 | Double acting spool(Bucket) | 12 | Adaptor & check valve |
| 4 | Double acting spool(Boom) | 13 | Shuttle valve assembly |
| 5 | Bucket spool centering | 14 | Anti-cavitation check valve assembly |
| 6 | Boom spool centering | 15 | 1/4" BSPP plug |
| 7 | Combined overload & anti-cavitation assembly | 16 | Check valve assembly |
| 8 | Back pressure valve | 17 | Pilot valve assembly |
| 9 | Check valve assembly | | |

STRUCTURE

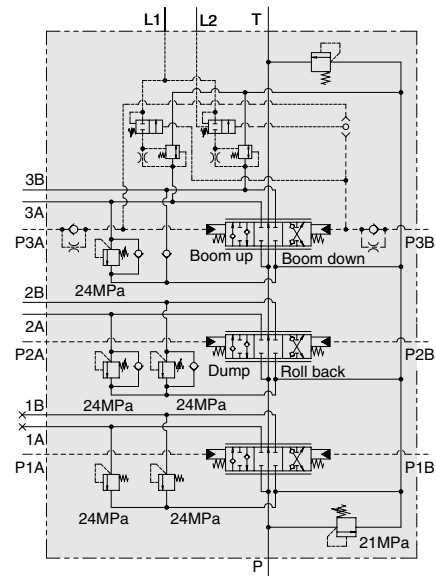
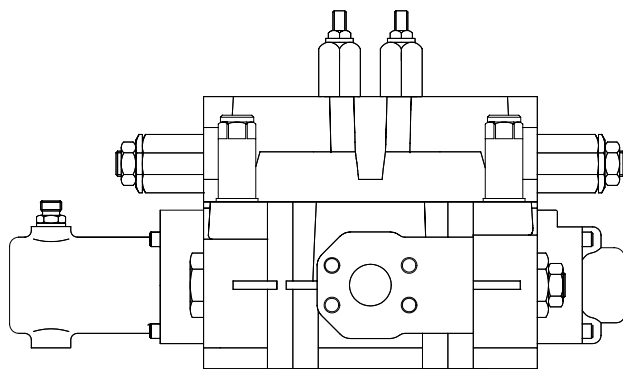
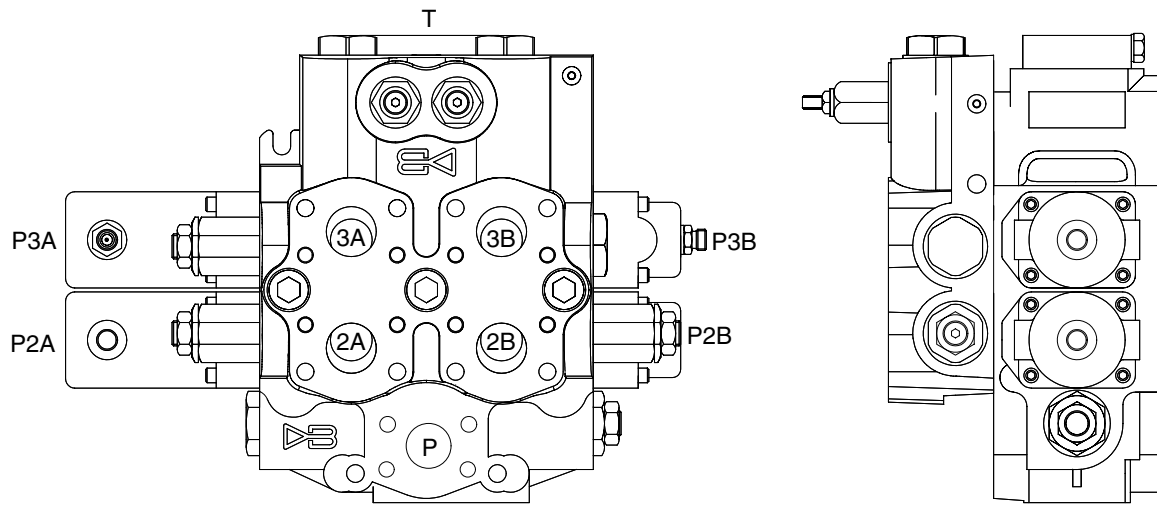

7707WE71

Port	Port name	Port size
P	From main pump	1-1/4" SAE split flange
T	To hydraulic tank	2" SAE split flange
2A, 2B	To bucket cylinder port	1-1/2" split flange
3A, 3B	To boom cylinder port	1-1/2" split flange
P3A, P3B	Boom pilot port	PF 3/8" fitting
P2A, P2B	Bucket pilot port	9/16" -18 UNF

2) BOOM SECTION OPERATION

(1) Spool in neutral

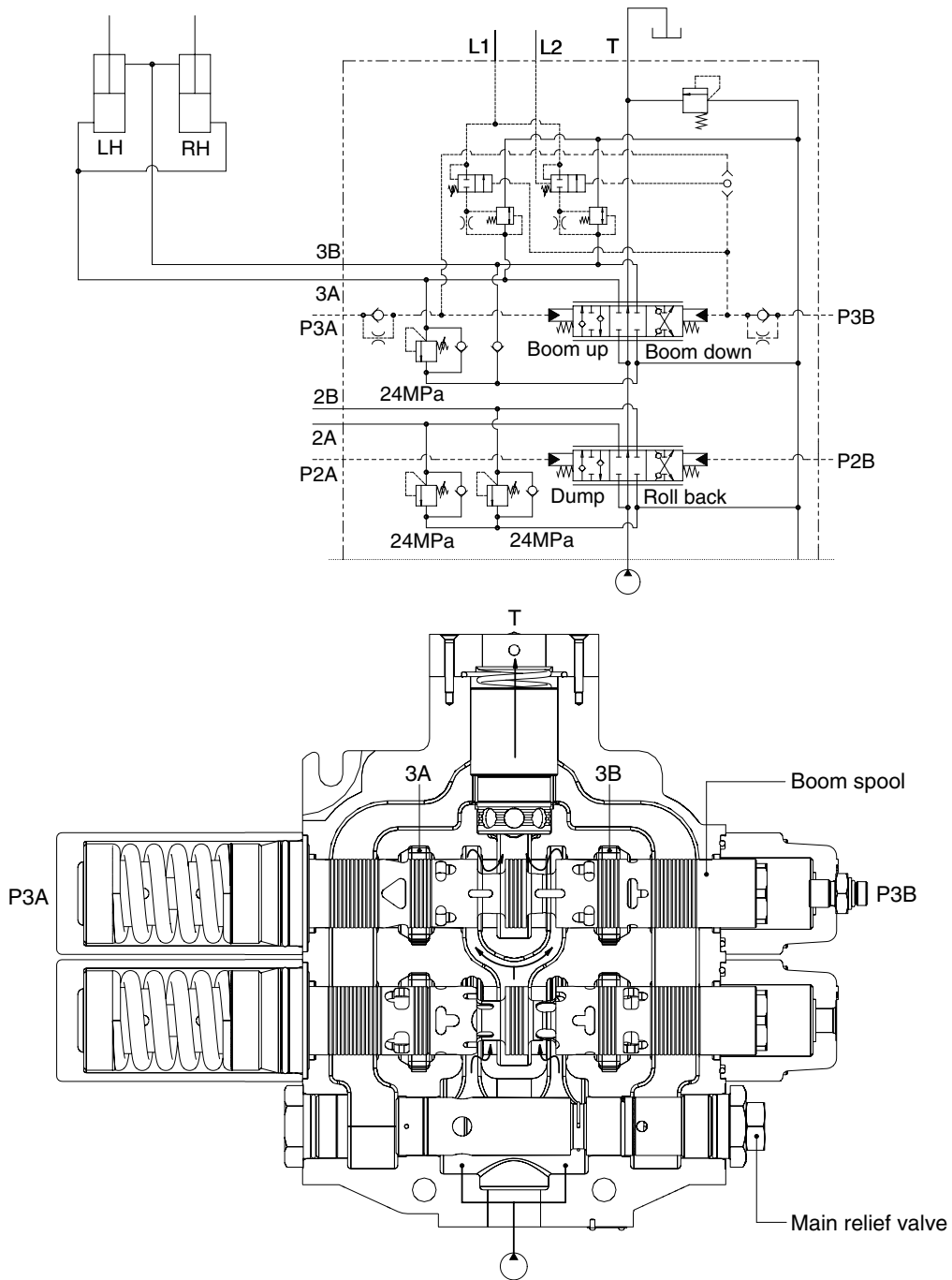

7707WE72

If the remote control valve is not operated, the oil supplied from the pump port passes through the neutral passage to the low pressure passage at the outlet section, and then returns to the tank port.

(2) Boom raise position

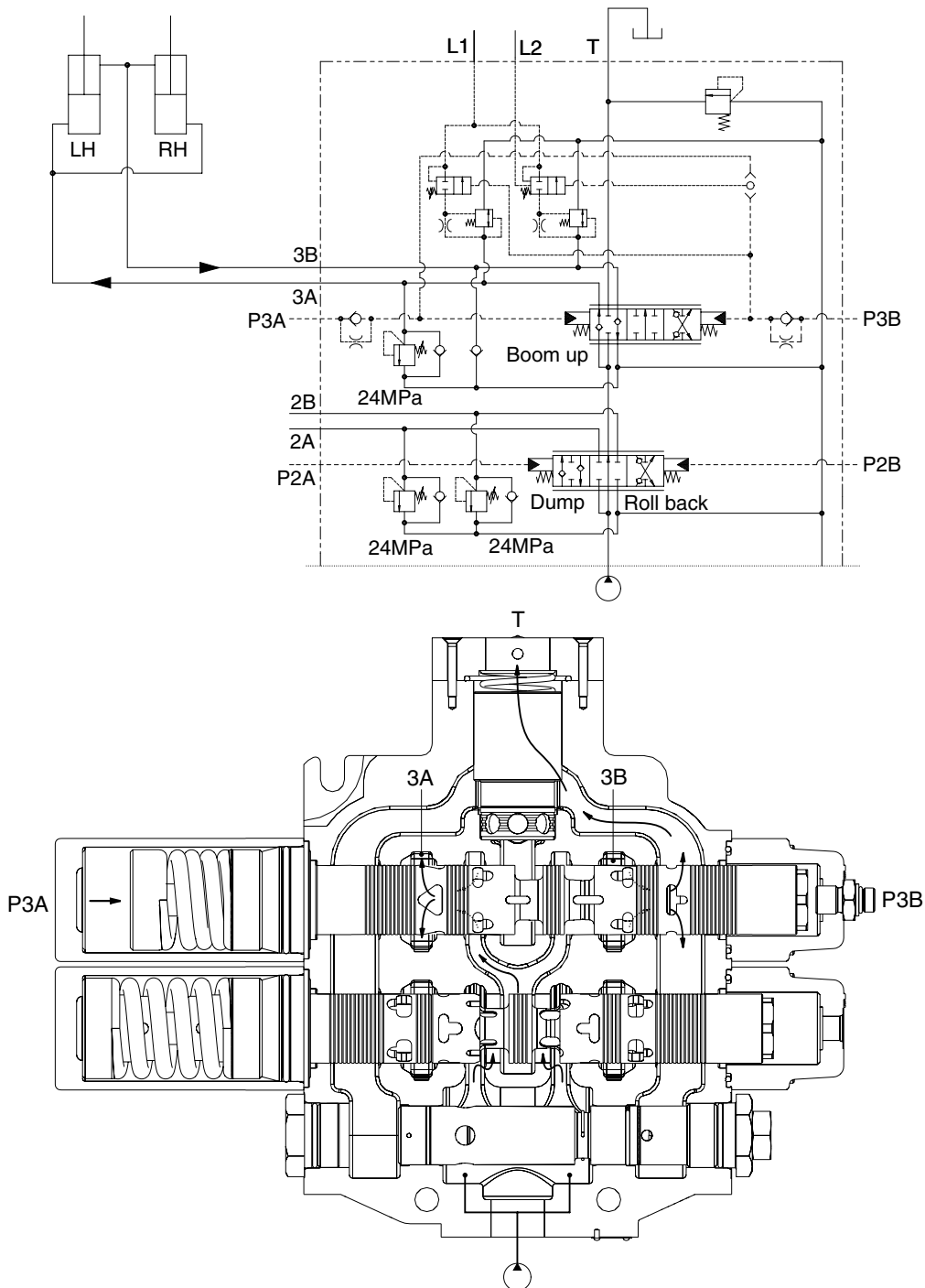

7707WE73

When the pilot pressure from remote control valve is supplied to the pilot port (P3A), the spool moves to the right and the neutral passage is closed.

The oil supplied from the pump flow into boom cylinder port (3A).

The pump pressure reaches proportionally the load of cylinder and fine control finished by shut off of the neutral passage.

The return oil from cylinder port (3B) flows into the tank via the low pressure passage.

(3) Boom lower position

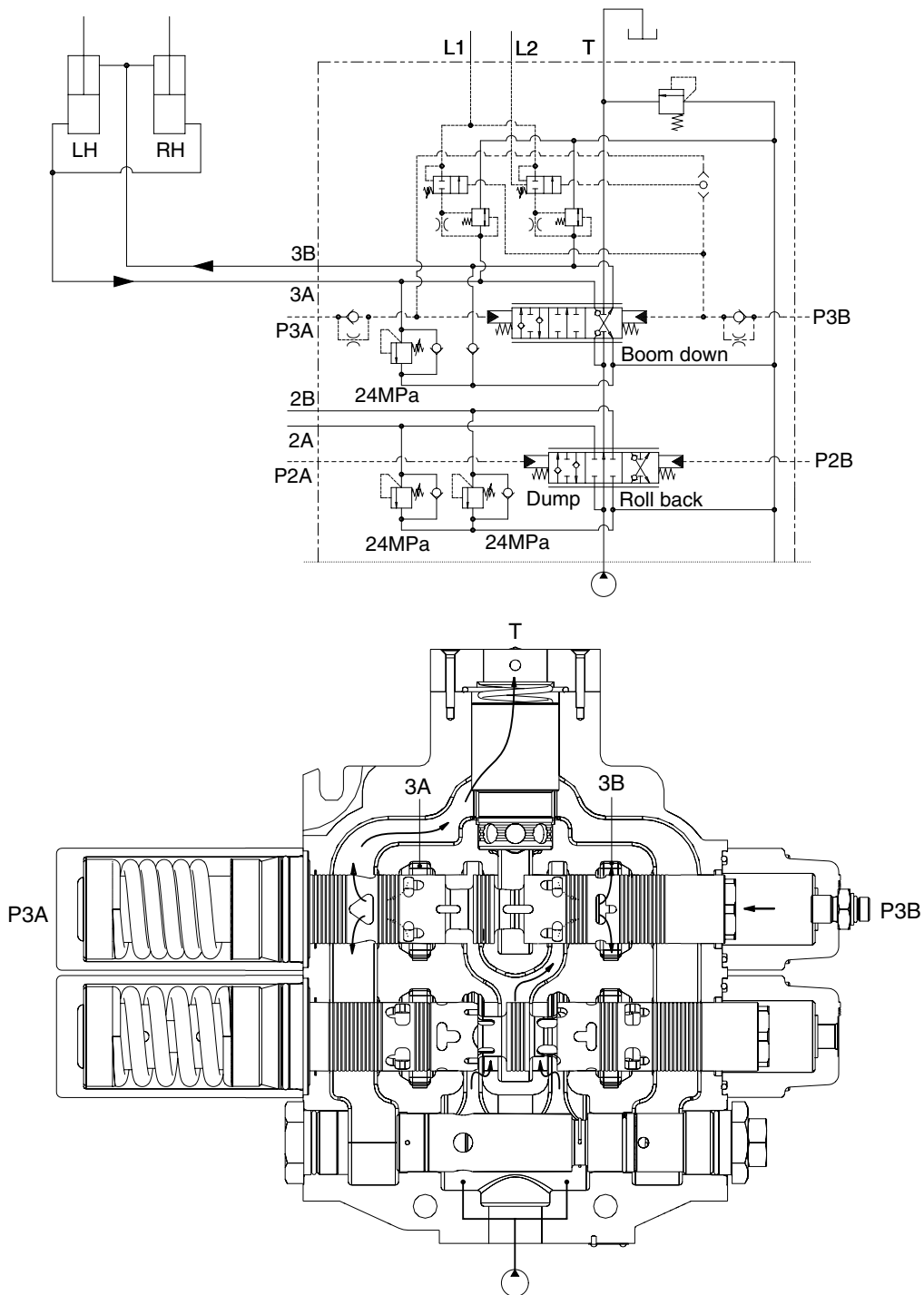

7707WE74

When the pilot pressure from remote control valve is supplied to the pilot port (P3B), the spool moves to the left and the neutral passage is closed.

The oil supplied from the pump flow into boom cylinder port (3B).

The pump pressure reaches proportionally the load of cylinder and fine control finished by shut off of the neutral passage.

The return oil from cylinder port (3A) flows into the tank via the low pressure passage.

※ **Boom float position** : Refer to page 6-6.

3) BUCKET SECTION OPERATION

(1) Spool in neutral

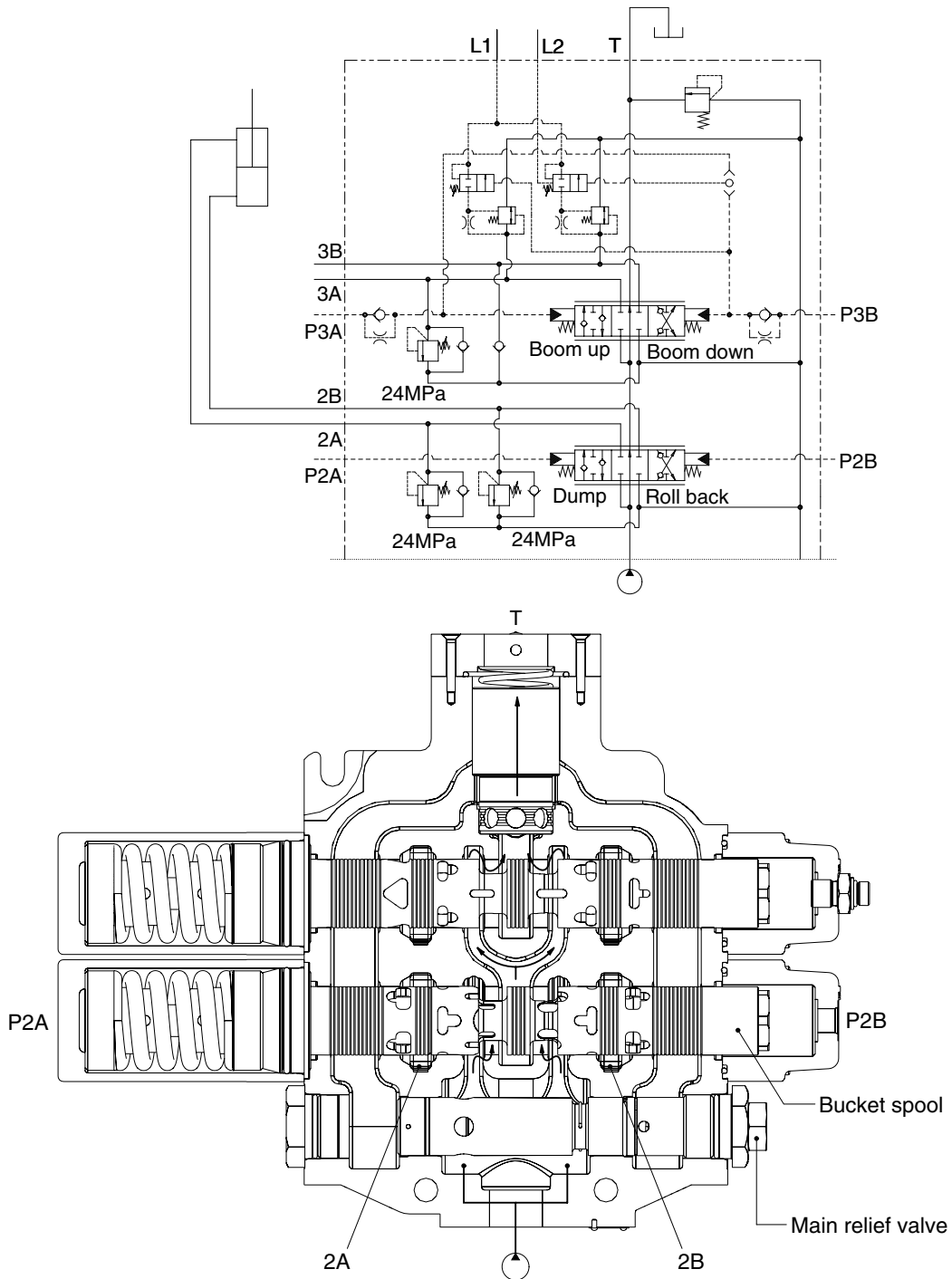

7707WE75

If the remote control valve is not operated, the oil supplied from the pump port passage through the neutral passage to the low pressure passage at the outlet section, and then return to the tank port.

(2) Retract (Roll back) position

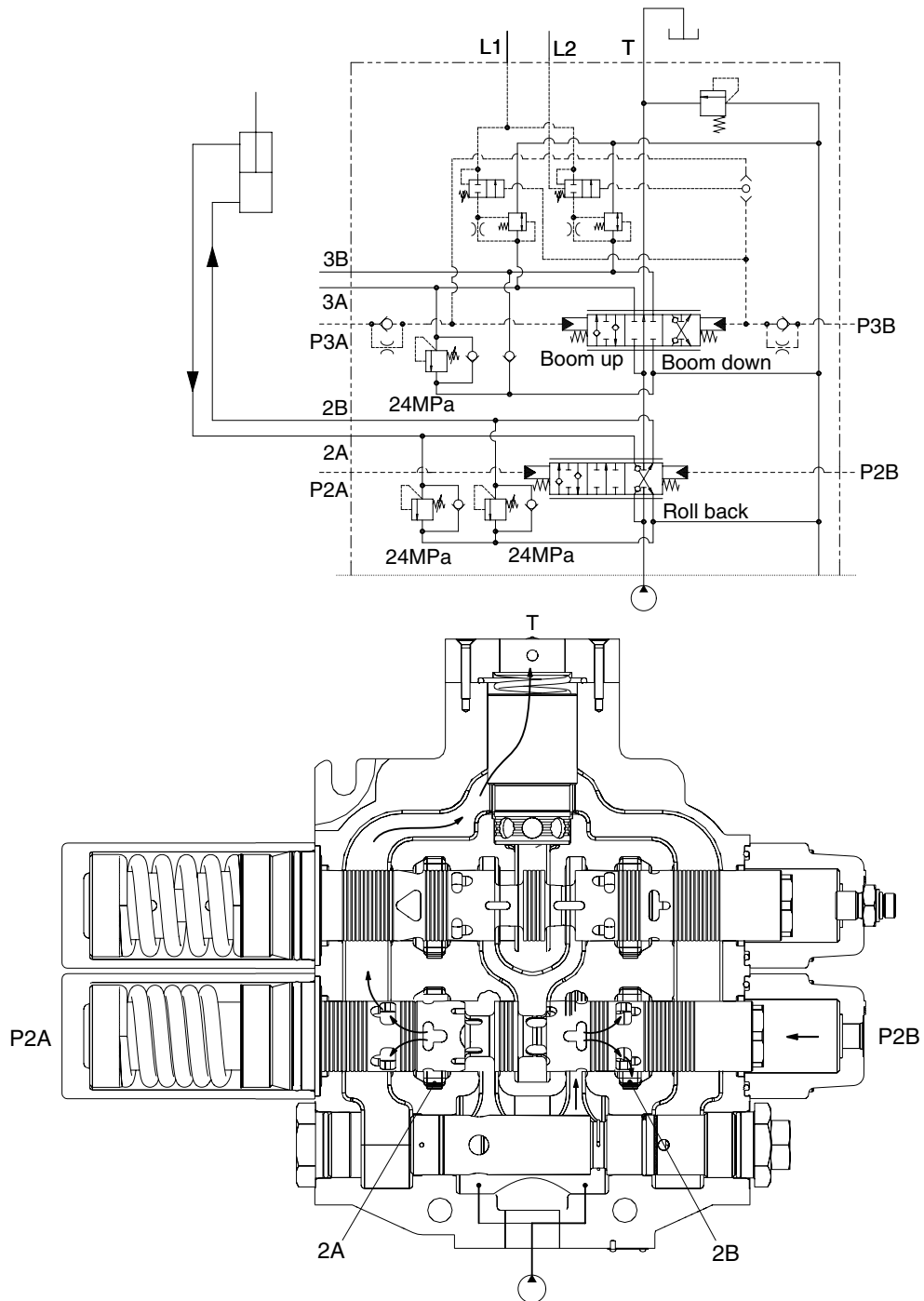

7707WE77

When the pilot pressure from remote control valve is supplied to the pilot port(P2B), the spool moves to the left and the neutral passage is closed.

The oil supplied from the pump flow into bucket cylinder port(2B).

The pump pressure reaches proportionally the load of cylinder and fine control finished by shut off of the neutral passage.

The return oil from cylinder port(2A) flows into the tank via the low pressure passage.

(3) Dump position

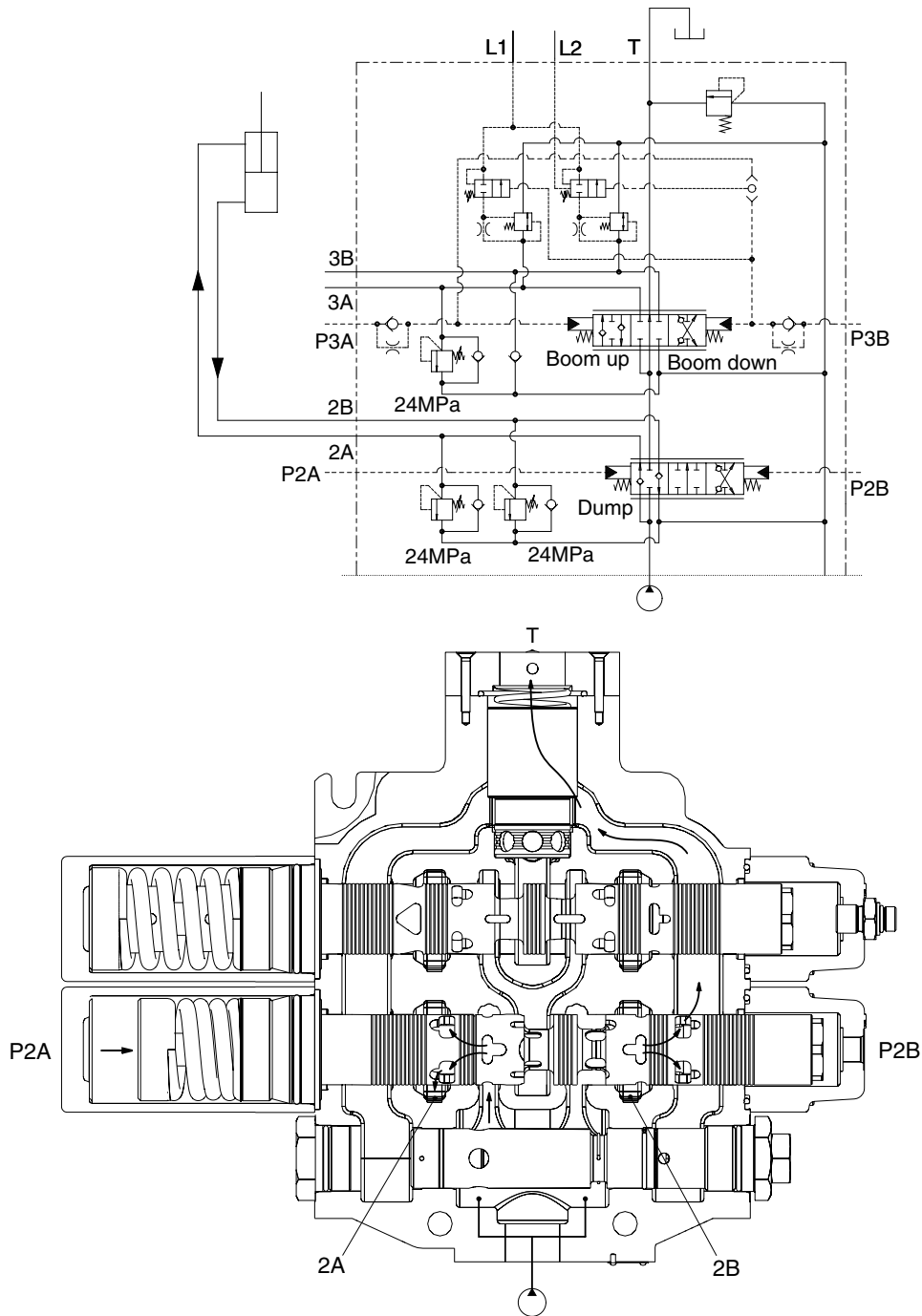

7707WE76

When the pilot pressure from remote control valve is supplied to the pilot port (P2A), the spool moves to the right and the neutral passage is closed.

The oil supplied from the flow into boom cylinder port (2A).

The pump pressure reaches proportionally the load of cylinder and fine control finished by shut off of the neutral passage.

The return oil from cylinder port (2B) flows into the tank via the low pressure passage.

7. PILOT OIL SUPPLY UNIT

1) STRUCTURE

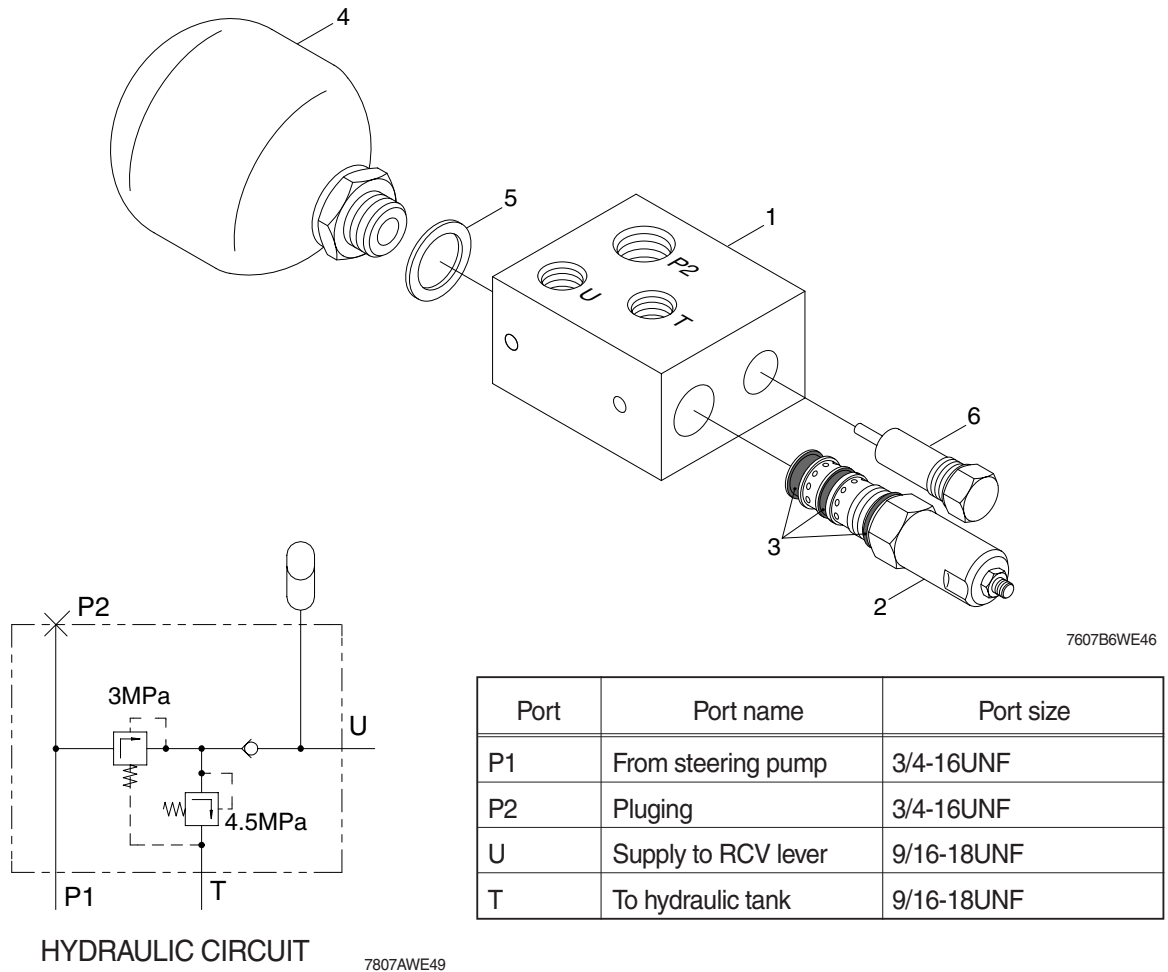

- | | |
|---|---|
| <ul style="list-style-type: none"> 1 Manifold complete 2 Reducing valve 3 Seal kit | <ul style="list-style-type: none"> 4 Accumulator 5 Gasket 6 Relife valve |
|---|---|

(2) OPERATION

The pilot supply manifold reduces the pressure from the high pressure circuit to a low pressure circuit in order to supply the remote control valve.

The accumulator satisfies short term peak power demands and is a source of emergency power in case of main circuit pressure failures.

The unit consists of the housing, the accumulator(4), the relief valve (6), the check valve and the reducing valve (2).

The flow path is from the high pressure circuit through port P2 to the pressure reducing valve (2). The pressure is reduced in the reducing valve (2) and oil passes the check valve into the accumulator (4) and to the port U, which is connected with the remote control valve.

The pressure relief valve (6) protects the pilot circuit in case of the reducing valve (2) failures or external increase of pressure.

8. BOOM AND BUCKET CYLINDER

The boom cylinders and the bucket cylinders are two unit. They use a bolt on rod guide.

The piston (12) threads on to the rod (2) and is retained by a nut (18) and set screw (19).

The piston seals against the tube (1) with piston seal (15). Two wear rings (16) are located on each side of the piston seal.

The gland (3, the rod guide) seals against the tube with an O-ring (10). The cylinder thread seals against the rod with a lip type buffer ring (7) and a rod seal (5). A dust wiper (8) cleans the rod when it is retracted.

1) BOOM CYLINDER

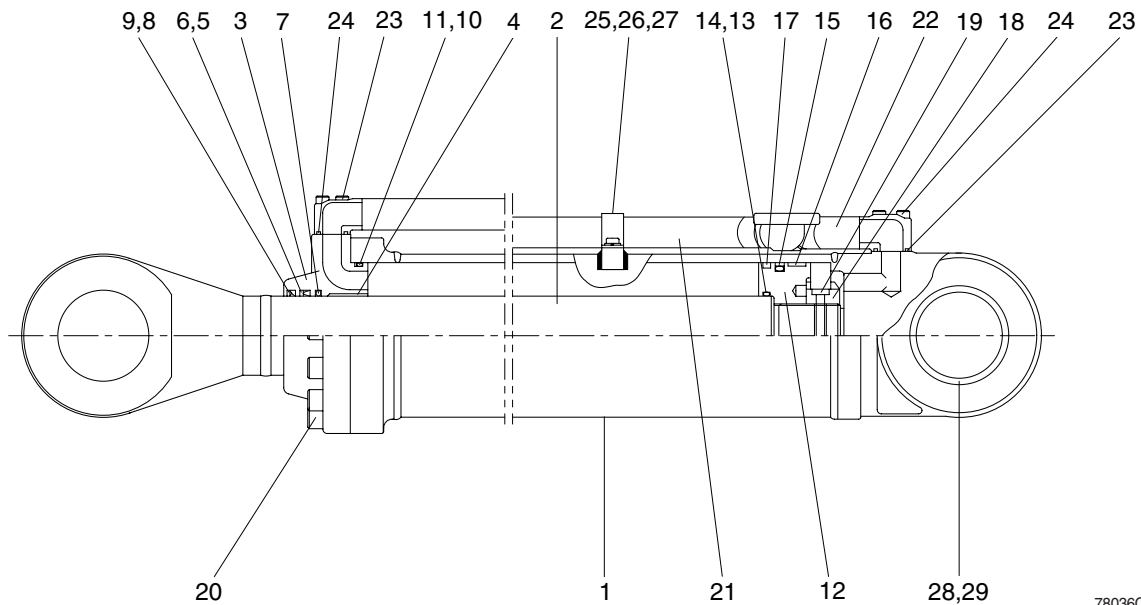

78036CY02

1	Tube assy	11	Back up ring	21	Pipe assy
2	Rod assy	12	Piston	22	Pipe assy
3	Gland	13	O-ring	23	O-ring
4	Bushing	14	Back up ring	24	Bolt
5	Rod seal	15	Piston seal	25	Clamp
6	Back up ring	16	Wear ring	26	Bolt
7	Buffer ring	17	Dust ring	27	Spring washer
8	Dust wiper	18	Lock nut	28	Bushing
9	Snap ring	19	Set screw	29	Dust seal
10	O-ring	20	Bolt		

2) BUCKET CYLINDER

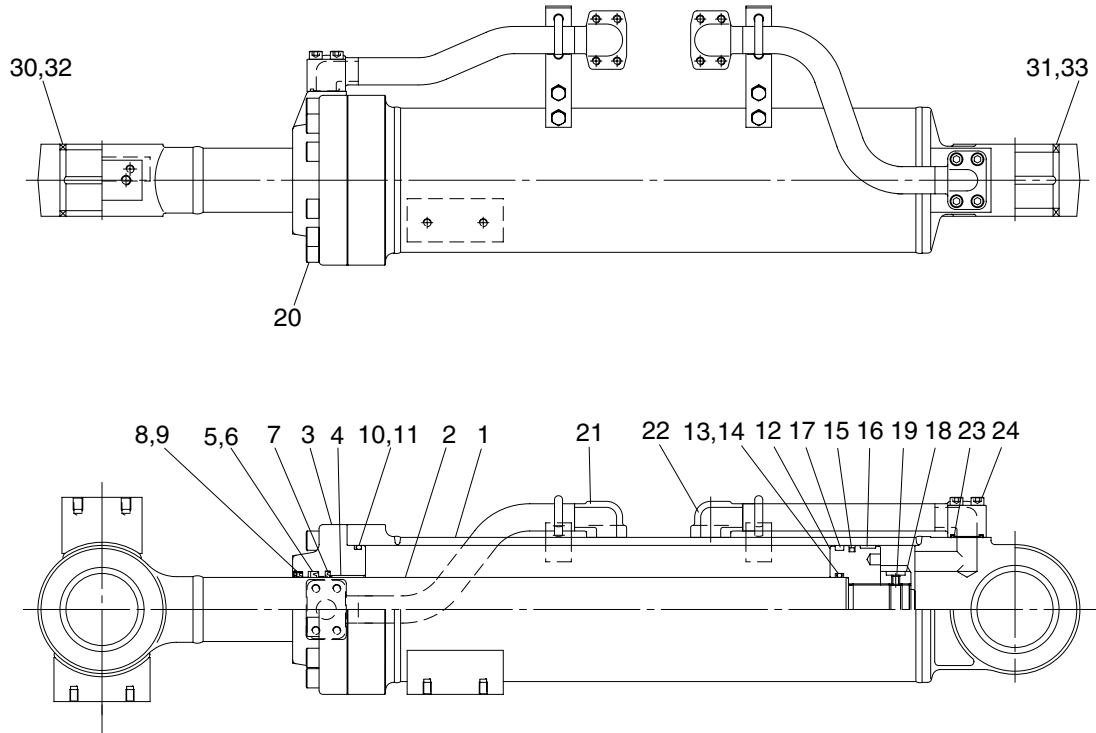

7807AWE13

1	Tube assy	12	Piston	23	O-ring
2	Rod assy	13	O-ring	24	Bolt
3	Gland	14	Back up ring	25	Bracket
4	Du bush	15	Piston seal	26	Bolt
5	Rod seal	16	Wear ring	27	Spring washer
6	Back up ring	17	Dust ring	28	U-bolt
7	Buffer ring	18	Lock nut	29	Nut
8	Dust wiper	19	Screw	30	Pin bush
9	Snap ring	20	Bolt	31	Pin bush
10	O-ring	21	Pipe assy	32	Dust seal
11	Back up ring	22	Pipe assy	33	Dust seal

9. HYDRAULIC OIL TANK

1) STRUCTURE

- The oil from the hydraulic tank is sent from the pump through main control valve to the cylinders. In the return circuit, the oil from various parts merges.
- A part of oil is cooled in the oil cooler, passes through the hydraulic filter and returns to the hydraulic tank (1).
- If the hydraulic return oil filter becomes clogged, return filter bypass valve (7) acts to allow the oil to return directly to the hydraulic tank (1). This prevents damage to the hydraulic filter (6). The bypass valve (7) is also actuated when negative pressure is generated in the circuit.

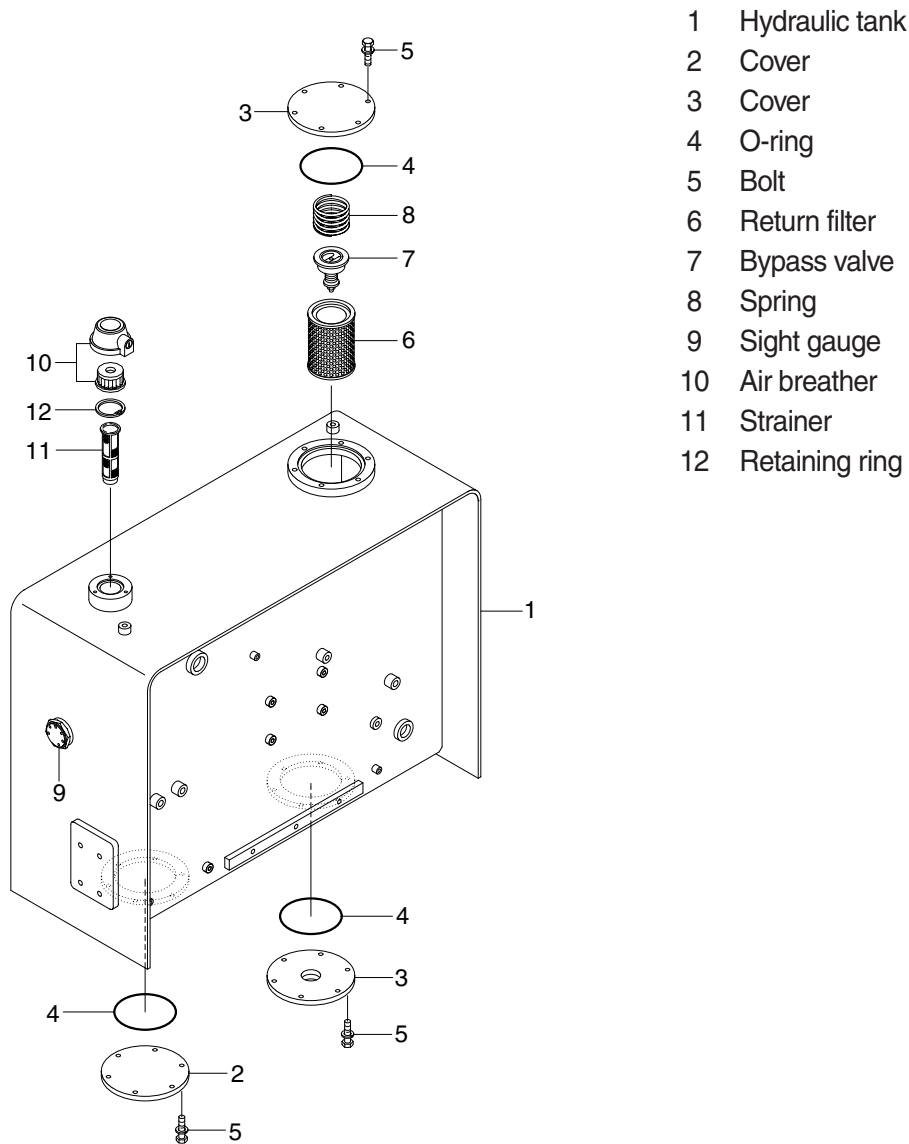

7809S6WE22

2) RETURN OIL FILTER BYPASS VALVE

(1) When the filter is clogged

Bypass valve (1) is opened and the oil returns directly to the tank without passing through the filter.

- Bypass valve set pressure : 1.36 kg/cm²
(19.3 psi)

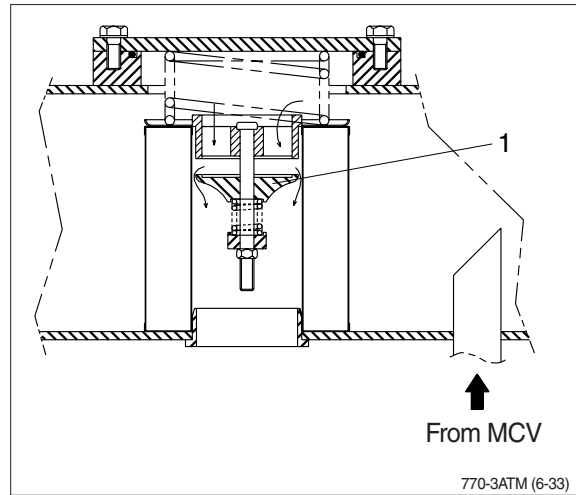

3) AIR BREATHER

The air breather is equipped with the capacity to perform three functions simultaneously-as an air filter, breathing valve, and as a lubrication opening.

(1) Preventing negative pressure inside the tank

The tank is a pressurized sealed type, so negative pressure is formed inside the hydraulic tank when the oil level drops during operations. When this happens, the difference in pressure between the tank and the outside atmospheric pressure opens the poppet in the breather, and air from the outside is let into the tank or prevent negative pressure.

(2) Preventing excessive pressure inside the tank

When the hydraulic cylinder is being used, the oil level in the hydraulic system increases and as temperature rises. If the hydraulic pressure rises above the set pressure, breather is actuated to release the hydraulic pressure inside the tank.

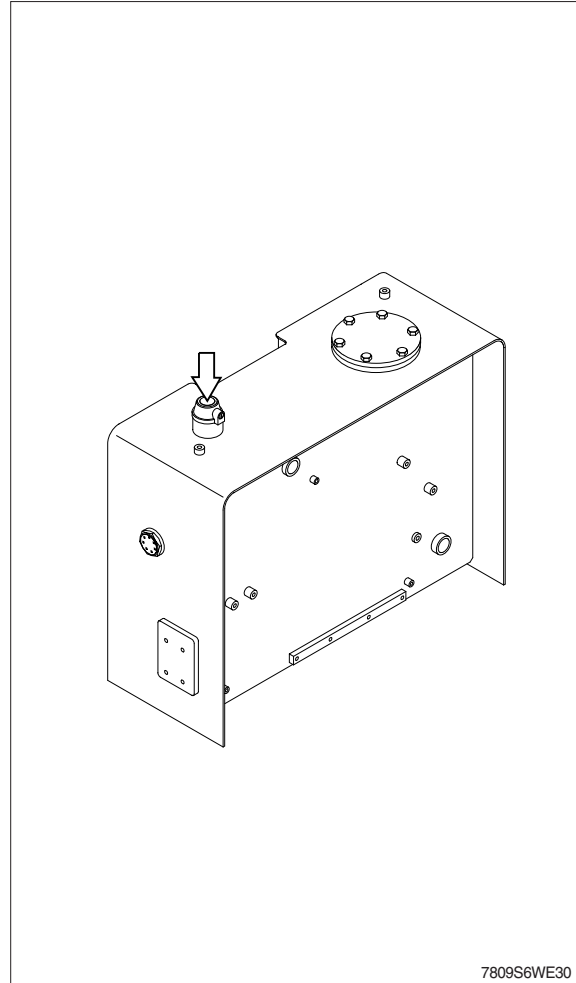

10. ACCUMULATOR

The accumulator is installed at the safety valve. When the boom is left the raised position, and the control levers are operated with the engine stopped the pressure of the compressed nitrogen gas inside the accumulator sends pilot pressure to the control valve to actuate it and allow the boom and bucket to come down under their own weight.

Type of gas	Nitrogen gas (N ₂)
Volume of gas	0.75 l (0.2 U.S.gal)
Charging pressure of gas	16 kg/cm ² (228 psi)
Max actuating pressure	128 kg/m ² (1820 psi)

