

GROUP 2 SPECIFICATION

1. MAJOR COMPONENT

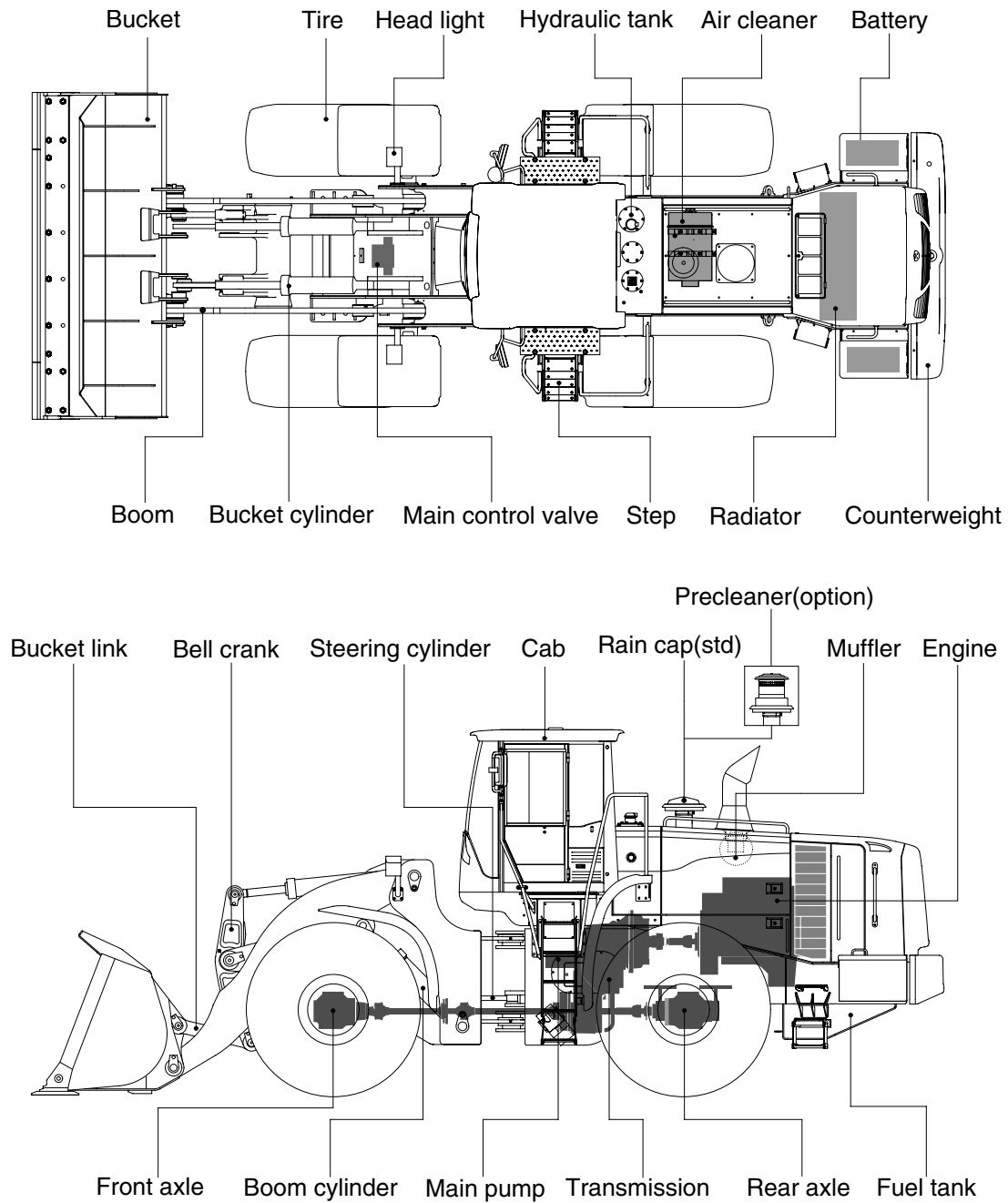

7809S2SE01

2. SPECIFICATIONS

1) WITH BOLT-ON CUTTING EDGE TYPE BUCKET (HL780-9S)

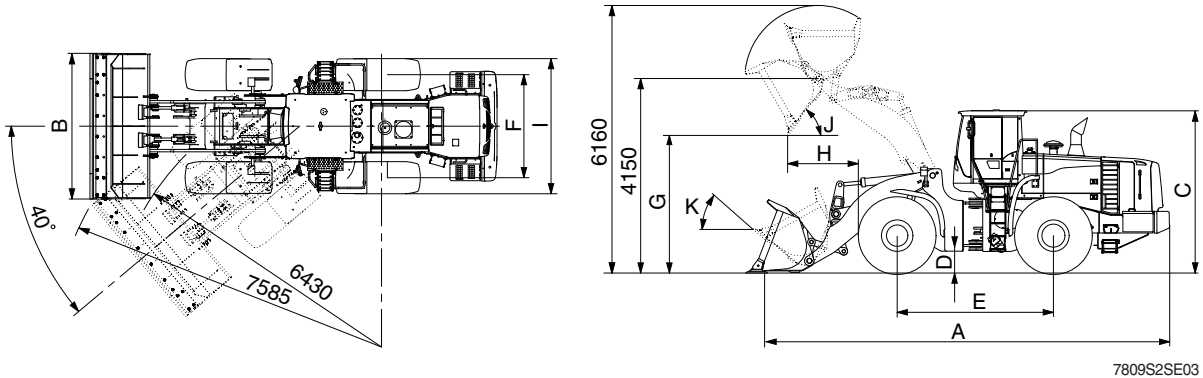

Description		Unit	Specification	
Operating weight		kg (lb)	29500 (65040)	
Bucket capacity	Struck	m ³ (yd ³)	4.3 (5.6)	
	Heaped		5.1 (6.7)	
Overall length	A	mm (ft-in)	9475 (31' 1")	
Overall width	B		3450 (11' 4")	
Overall height	C		3880 (12' 9")	
Ground clearance	D		495 (1' 7")	
Wheelbase	E		3700 (12' 2")	
Tread	F		2440 (8' 0")	
Dump clearance at 45°	G		3300 (10' 10")	
Dump reach (full lift)	H		1365 (4' 6")	
Width over tires	I		3220 (10' 7")	
Dump angle	J		degree (°)	47
Roll back angle (carry position)	K			48
Cycle time	Lift (with load)	sec	6.7	
	Dump (with load)		1.4	
	Lower (empty)		3.0	
Maximum travel speed		km/hr (mph)	36.5 (22.7)	
Braking distance		m (ft-in)	12 (39' 4")	
Minimum turning radius (center of outside tire)			6.43 (21' 1")	
Gradeability		degree (°)	30	
Brakeout force		kg (lb)	24820 (54720)	
Travel speed	Forward	First gear	6.1 (3.8)	
		Second gear	11.5 (7.1)	
		Third gear	18.0 (11.2)	
		Fourth gear	36.5 (22.7)	
	Reverse	First gear	6.1 (3.8)	
		Second gear	11.5 (7.1)	
Third gear		25.0 (15.5)		

WITH BOLT-ON CUTTING EDGE TYPE BUCKET (HL780XTD-9S)

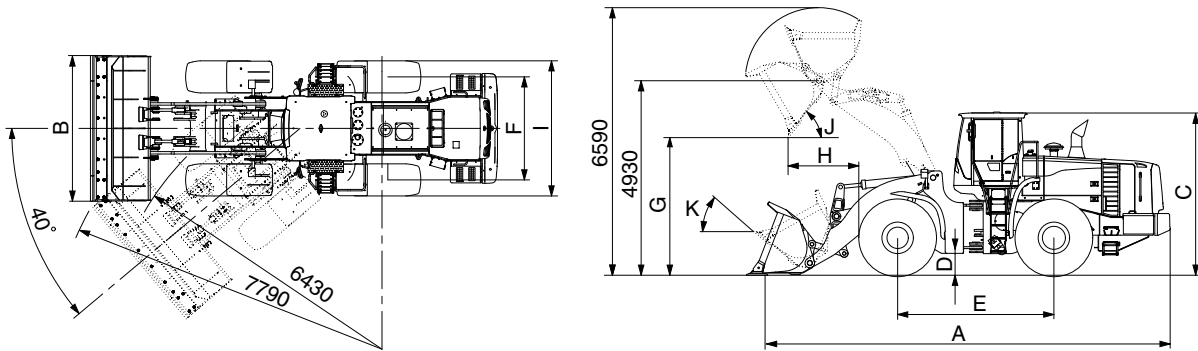

7809S2SE03-1

Description		Unit	Specification	
Operating weight		kg (lb)	30200 (66580)	
Bucket capacity	Struck	m ³ (yd ³)	4.3 (5.6)	
	Heaped		5.1 (6.7)	
Overall length	A	mm (ft-in)	9970 (32' 9")	
Overall width	B		3450 (11' 4")	
Overall height	C		3880 (12' 9")	
Ground clearance	D		495 (1' 7")	
Wheelbase	E		3700 (12' 2")	
Tread	F		2440 (8' 0")	
Dump clearance at 45°	G		3720 (12' 2")	
Dump reach (full lift)	H		1430 (4' 8")	
Width over tires	I		3220 (10' 7")	
Dump angle	J		degree (°)	47
Roll back angle (carry position)	K			49
Cycle time	Lift (with load)	sec	6.7	
	Dump (with load)		1.4	
	Lower (empty)		3.0	
Maximum travel speed		km/hr (mph)	36.5 (22.7)	
Braking distance		m (ft-in)	12 (39' 4")	
Minimum turning radius (center of outside tire)			6.43 (21' 1")	
Gradeability		degree (°)	30	
Brakeout force		kg (lb)	23880 (52650)	
Travel speed	Forward	First gear	6.1 (3.8)	
		Second gear	11.5 (7.1)	
		Third gear	18.0 (11.2)	
		Fourth gear	36.5 (22.7)	
	Reverse	First gear	6.1 (3.8)	
		Second gear	11.5 (7.1)	
Third gear		25.0 (15.5)		

2) WITH TOOTH TYPE BUCKET (HL780-9S)

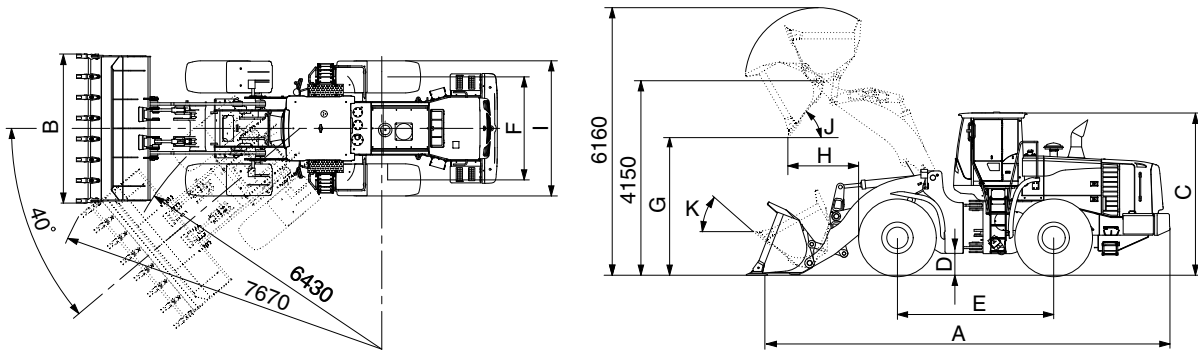

7809S2SE04

Description		Unit	Specification	
Operating weight		kg (lb)	29500 (65040)	
Bucket capacity	Struck	m ³ (yd ³)	4.1 (5.4)	
	Heaped		4.8 (6.3)	
Overall length	A	mm (ft-in)	9655 (31' 8")	
Overall width	B		3500 (11' 6")	
Overall height	C		3880 (12' 9")	
Ground clearance	D		495 (1' 7")	
Wheelbase	E		3700 (12' 2")	
Tread	F		2440 (8' 0")	
Dump clearance at 45°	G		3140 (10' 4")	
Dump reach (full lift)	H		1485 (4' 10")	
Width over tires	I		3220 (10' 7")	
Dump angle	J		degree (°)	47
Roll back angle (carry position)	K			48
Cycle time	Lift (with load)	sec	6.7	
	Dump (with load)		1.4	
	Lower (empty)		3.0	
Maximum travel speed		km/hr (mph)	36.5 (22.7)	
Braking distance		m (ft-in)	12 (39' 4")	
Minimum turning radius (center of outside tire)			6.43 (21' 1")	
Gradeability		degree (°)	30	
Brakeout force		kg (lb)	26340 (58070)	
Travel speed	Forward	First gear	6.1 (3.8)	
		Second gear	11.5 (7.1)	
		Third gear	18.0 (11.2)	
		Fourth gear	36.5 (22.7)	
	Reverse	First gear	6.1 (3.8)	
		Second gear	11.5 (7.1)	
Third gear		25.0 (15.5)		

WITH TOOTH TYPE BUCKET (HL780XTD-9S)

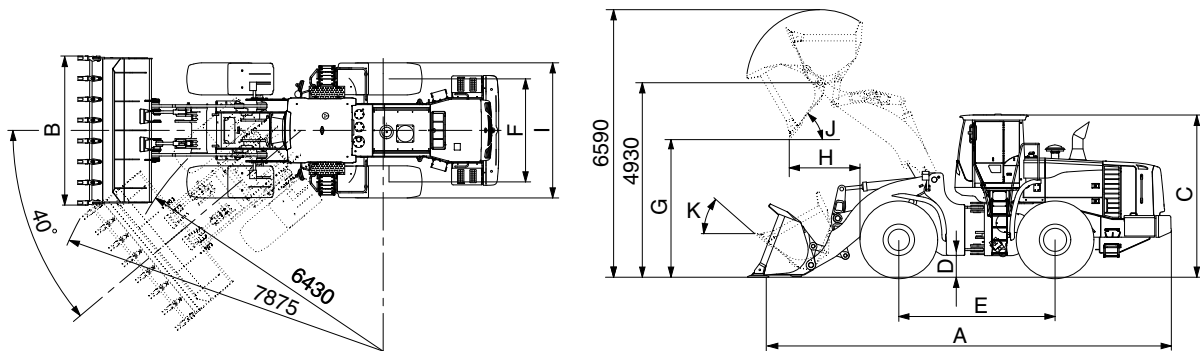

7809S2SE04-1

Description		Unit	Specification	
Operating weight		kg (lb)	30200 (66580)	
Bucket capacity	Struck	m ³ (yd ³)	4.1 (5.4)	
	Heaped		4.8 (6.3)	
Overall length	A	mm (ft-in)	10150 (33' 4")	
Overall width	B		3500 (11' 6")	
Overall height	C		3880 (12' 9")	
Ground clearance	D		495 (1' 7")	
Wheelbase	E		3700 (12' 2")	
Tread	F		2440 (8' 0")	
Dump clearance at 45°	G		3565 (11' 8")	
Dump reach (full lift)	H		1545 (5' 1")	
Width over tires	I		3220 (10' 7")	
Dump angle	J		degree (°)	47
Roll back angle (carry position)	K			49
Cycle time	Lift (with load)	sec	6.7	
	Dump (with load)		1.4	
	Lower (empty)		3.0	
Maximum travel speed		km/hr (mph)	36.5 (22.7)	
Braking distance		m (ft-in)	12 (39' 4")	
Minimum turning radius (center of outside tire)			6.43 (21' 1")	
Gradeability		degree (°)	30	
Brakeout force		kg (lb)	25520 (56260)	
Travel speed	Forward	First gear	6.1 (3.8)	
		Second gear	11.5 (7.1)	
		Third gear	18.0 (11.2)	
		Fourth gear	36.5 (22.7)	
	Reverse	First gear	6.1 (3.8)	
		Second gear	11.5 (7.1)	
Third gear		25.0 (15.5)		

3. WEIGHT

Item	kg	lb	
Front frame assembly	2697	5950	
Rear frame assembly	3595	7930	
Front fender (LH & RH)	48	106	
Counterweight	1300	2870	
Additional counterweight (HL780XTD-9S)	552	1220	
Cab assembly	780	1720	
Engine assembly	984	2170	
Transmission assembly	780	1720	
Drive shaft (front)	25	55	
Drive shaft (center)	48	106	
Drive shaft (rear)	30	66	
Drive shaft (upper)	14	31	
Front axle (include differential)	1814	4000	
Rear axle (include differential)	1805	3980	
Tire (29.5-25, 22PR, L3)	430	948	
Hydraulic tank assembly	300	661	
Fuel tank assembly	374	825	
Main pump	38.6	85	
Steering pump	38.6	85	
Main control valve (2 / 3 spool)	95 / 115	209 / 254	
Flow amplifier	29	64	
Boom assembly	HL780-9S	2060	4540
	HL780XTD-9S	2260	4980
Bell crank assembly	282	620	
Bucket link	55	120	
5.1 m ³ bucket, with bolt on cutting edge	2590	5710	
4.8 m ³ bucket, with tooth	2460	5420	
Boom cylinder assembly (2EA)	290	639	
Bucket cylinder assembly (2EA)	130	287	
Steering cylinder assembly (2EA)	60	132	
Seat	40	88	
Battery	55	121	

4. SPECIFICATION FOR MAJOR COMPONENTS

1) ENGINE

Item	Specification
Model	Cummins QSM 11
Type	4-cycle turbocharged, charge air cooled diesel engine
Control type	Electronic control
Cooling method	Water cooling
Number of cylinders and arrangement	6 cylinders, in-line
Firing order	1-5-3-6-2-4
Combustion chamber type	Direct injection type
Cylinder bore × stroke	125 × 147 mm (4.92" × 5.79")
Piston displacement	10800 cc (659 cu in)
Compression ratio	16.3 : 1
Rated gross horse power	353 ps at 2000 rpm
Maximum gross torque at 1400 rpm	171 kgf · m (1235 lbf · ft)
Engine oil quantity	38 l (10 U.S. gal)
Wet weight	984 kg (2170 lb)
High idling speed	2130 ± 50 rpm
Low idling speed	800 ± 50 rpm
Rated fuel consumption	218 g/kw-hr
Starting motor	Delco Remy 39MT (24 V)
Alternator	Delco Remy 24SI (24 V - 70 Amp)
Battery	2 × 12V × 220Ah

2) MAIN PUMP + BRAKE PUMP (MACHINE SERIAL NO. : -#0182)

Item	Specification	
	Main pump	Brake pump
Type	Fixed displacement double vane pump	
Capacity	113.5 cc/rev	15.9 cc/rev
Maximum operating pressure	210 kgf/cm ² (2990 psi)	150 kgf/cm ² (2130 psi)
Rated oil quantity	212 l /min (56 U.S.gpm)	30 l /min (7.9 U.S.gpm)
Rated speed	2000 rpm	

3) STEERING PUMP + FAN PUMP (MACHINE SERIAL NO. : -#0182)

Item	Specification	
	Steering	Fan pump
Type	Fixed displacement double vane pump	
Capacity	137.5 cc/rev	24.9 cc/rev
Maximum operating pressure	210 kgf/cm ² (2990 psi)	140 kgf/cm ² (1990 psi)
Rated oil quantity	270 l /min (71.3 U.S.gpm)	49 l /min (12.9 U.S.gpm)
Rated speed	2000 rpm	

4) MAIN PUMP (MACHINE SERIAL NO. : #0183-)

Item	Specification
Type	Single spur gear pump
Capacity	112 cc/rev
Maximum operating pressure	220 kgf/cm ² (3130 psi)
Rated speed	2000 rpm

5) STEERING PUMP (MACHINE SERIAL NO. : #0183-)

Item	Specification
Type	Single spur gear pump
Capacity	139 cc/rev
Maximum operating pressure	220 kgf/cm ² (3130 psi)
Rated speed	2000 rpm

6) FAN + BRAKE PUMP (MACHINE SERIAL NO. : #0183-)

Item	Specification	
	Fan	Brake
Type	Tandem spur gear pump	
Capacity	26 cc/rev	26 cc/rev
Maximum operating pressure	280 kgf/cm ² (3980 psi)	170 kgf/cm ² (2420 psi)
Rated speed	2000 rpm	

7) MAIN CONTROL VALVE

Item	Specification
Type	2 spool
Operating method	Hydraulic pilot assist
Main relief valve pressure	210 kgf/cm ² (2990 psi)
Overload relief valve pressure	240 kgf/cm ² (3140 psi)

8) REMOTE CONTROL VALVE

Item	Specification	
Type	Pressure reducing type	
Operating	Minimum	5 kgf/cm ² (71 psi)
	Maximum	30 kgf/cm ² (427 psi)
Single operation angle	Degree	17

9) CYLINDER

Item		Specification
Boom cylinder	Bore dia × Rod dia × Stroke	∅ 200 × ∅ 110 × 863 mm
Bucket cylinder	Bore dia × Rod dia × Stroke	∅ 160 × ∅ 80 × 580 mm
Steering cylinder	Bore dia × Rod dia × Stroke	∅ 110 × ∅ 55 × 480 mm

10) DYNAMIC POWER TRANSMISSION DEVICES

Item		Specification	
Transmission	Model	ZF 4WG310	
	Type	Converter	Single-stage, double-phase
		Transmission	Full-automatic power shift
	Converter stall ratio	2.51 : 1	
	Gear shift	Forward fourth gear, reverse third gear	
	Control	Electrical single lever type, kick-down system, Automatic kick down from 2nd to 1st gear FNR Switch on joystick lever (option)	
	Pump rated flow	105 ℓ /min (27.7 U.S.gpm) at 2000 rpm	
Axle	Drive devices	4-wheel drive	
	Front	Front fixed location	
	Rear	Oscillation ± 13° of center pin-loaded	
Wheels	Tires	29.5-25, 22PR (L3)	
Brakes	Travel	Four-wheel, wet-disc type, full hydraulic	
	Parking	Spring applied, hydraulic released brake	
Steering	Type	Full hydraulic, articulated	
	Steering angle	40° to both right and left angle, respectively	

5. TIGHTENING TORQUE OF MAJOR COMPONENT

No.	Descriptions	Bolt size	Torque		
			kgf · m	lbf · ft	
1	Engine	Engine mounting bolt, nut (rubber, 4EA)	M24 × 3.0	100 ± 15.0	723 ± 108
2		Engine mounting bolt (flywheel housing, 14EA)	M10 × 1.5	4.6 ± 0.7	33.3 ± 5.1
3		Engine mounting bolt (coupling, 8EA)	1/2-13UNC	8.37 ± 0.41	53.3 ± 3.0
4		Engine mounting bolt (gear housing, 6EA)	M10 × 1.5	4.6 ± 0.7	33.3 ± 5.1
5		Radiator mounting bolt	M20 × 2.5	57.9 ± 8.7	419 ± 62.9
6		Fuel tank mounting bolt, nut	M16 × 2.0	29.7 ± 4.5	215 ± 32.5
7	Hydraulic system	Main pump housing mounting bolt	M16 × 2.0	29.7 ± 4.5	215 ± 32.5
8		Steering pump housing mounting bolt	M16 × 2.0	29.7 ± 4.5	215 ± 32.5
9		Main control valve mounting bolt	M12 × 1.75	12.8 ± 3.0	92.6 ± 21.7
10		Steering unit mounting bolt	M10 × 1.5	6.9 ± 1.4	49.9 ± 10.1
11		Flow amplifier mounting bolt	M10 × 1.5	6.9 ± 1.4	49.9 ± 10.1
12		Brake valve mounting bolt	M8 × 1.25	2.5 ± 0.5	18.1 ± 3.6
13		Cut-off valve mounting bolt	M12 × 1.75	12.3 ± 2.0	89.0 ± 14
14		Remote control lever mounting bolt	M6 × 1.0	1.1 ± 0.2	8.0 ± 1.4
15		Safety valve	M8 × 1.25	2.5 ± 0.5	18.1 ± 3.6
16		Hydraulic oil tank mounting bolt	M20 × 2.5	57.9 ± 8.7	419 ± 62.9
17	Power train system	Transmission mounting bolt, nut (rubber, 4EA)	M24 × 3.0	100 ± 15.0	723 ± 108
18		Transmission mounting bolt (bracket, 8EA)	M20 × 2.5	24.0 ± 2.4	174 ± 18.1
19		Transmission bolt (bracket, converter side)	M16 × 2.0	18.4 ± 2.0	133 ± 14.5
20		Front axle mounting bolt, nut	M36 × 3.0	270 ± 30	1950 ± 217
21		Rear axle support mounting bolt, nut	M36 × 3.0	270 ± 30	1950 ± 217
22		Tire mounting nut	M22 × 1.5	79 ± 2.5	571 ± 18
23		Drive shaft joint mounting bolt (front, center, rear)	1/2-20UNF	15.5 ± 0.5	112 ± 3.6
24		Drive shaft joint mounting bolt (upper)	1/2-20UNF	10.5 ± 0.5	75.9 ± 3.6
25	Others	Counterweight mounting bolt	M30 × 2.0	199 ± 30	1439 ± 217
26		Counterweight mounting bolt	M24 × 3.0	100 ± 15	723 ± 108
27		Operator's seat mounting bolt	M8 × 1.25	3.4 ± 0.8	24.6 ± 5
28		Cab mounting bolt (4EA)	M20 × 2.5	58 ± 8.7	419 ± 63

6. TORQUE CHART

Use following table for unspecified torque.

1) BOLT AND NUT

(1) Coarse thread

Bolt size	8T		10T	
	kg · m	lb · ft	kg · m	lb · ft
M 6 × 1.0	0.85 ~ 1.25	6.15 ~ 9.04	1.14 ~ 1.74	8.2 ~ 12.6
M 8 × 1.25	2.0 ~ 3.0	14.5 ~ 21.7	2.73 ~ 4.12	19.5 ~ 29.8
M10 × 1.5	4.0 ~ 6.0	28.9 ~ 43.4	5.5 ~ 8.3	39.8 ~ 60
M12 × 1.75	7.4 ~ 11.2	53.5 ~ 79.5	9.8 ~ 15.8	71 ~ 114
M14 × 2.0	12.2 ~ 16.6	88.2 ~ 120	16.7 ~ 22.5	121 ~ 167
M16 × 2.0	18.6 ~ 25.2	135 ~ 182	25.2 ~ 34.2	182 ~ 247
M18 × 2.5	25.8 ~ 35.0	187 ~ 253	35.1 ~ 47.5	254 ~ 343
M20 × 2.5	36.2 ~ 49.0	262 ~ 354	49.2 ~ 66.6	356 ~ 482
M22 × 2.5	48.3 ~ 63.3	350 ~ 457	65.8 ~ 98.0	476 ~ 709
M24 × 3.0	62.5 ~ 84.5	452 ~ 611	85.0 ~ 115	615 ~ 832
M30 × 3.0	124 ~ 168	898 ~ 1214	169 ~ 229	1223 ~ 1655
M36 × 4.0	174 ~ 236	1261 ~ 1703	250 ~ 310	1808 ~ 2242

(2) Fine thread

Bolt size	8T		10T	
	kg · m	lb · ft	kg · m	lb · ft
M 8 × 1.0	2.17 ~ 3.37	15.7 ~ 24.3	3.04 ~ 4.44	22.0 ~ 32.0
M10 × 1.25	4.46 ~ 6.66	32.3 ~ 48.2	5.93 ~ 8.93	42.9 ~ 64.6
M12 × 1.25	7.78 ~ 11.58	76.3 ~ 83.7	10.6 ~ 16.0	76.6 ~ 115
M14 × 1.5	13.3 ~ 18.1	96.2 ~ 130	17.9 ~ 24.1	130 ~ 174
M16 × 1.5	19.9 ~ 26.9	144 ~ 194	26.6 ~ 36.0	193 ~ 260
M18 × 1.5	28.6 ~ 43.6	207 ~ 315	38.4 ~ 52.0	278 ~ 376
M20 × 1.5	40.0 ~ 54.0	289 ~ 390	53.4 ~ 72.2	386 ~ 522
M22 × 1.5	52.7 ~ 71.3	381 ~ 515	70.7 ~ 95.7	512 ~ 692
M24 × 2.0	67.9 ~ 91.9	491 ~ 664	90.9 ~ 123	658 ~ 890
M30 × 2.0	137 ~ 185	990 ~ 1338	182 ~ 248	1314 ~ 1795
M36 × 3.0	192 ~ 260	1389 ~ 1879	262 ~ 354	1893 ~ 2561

2) PIPE AND HOSE (FLARE type)

Thread size	Width across flat (mm)	kgf · m	lbf · ft
1/4"	19	4	28.9
3/8"	22	5	36.2
1/2"	27	9.5	68.7
3/4"	36	18	130
1"	41	21	152
1-1/4"	50	35	253

3) PIPE AND HOSE (ORFS type)

Thread size	Width across flat (mm)	kgf · m	lbf · ft
9/16-18	19	4	28.9
11/16-16	22	5	36.2
13/16-16	27	9.5	68.7
1-3/16-12	36	18	130
1-7/16-12	41	21	152
1-11/16-12	50	35	253

4) FITTING

Thread size	Width across flat (mm)	kgf · m	lbf · ft
1/4"	19	4	28.9
3/8"	22	5	36.2
1/2"	27	9.5	68.7
3/4"	36	18	130
1"	41	21	152
1-1/4"	50	35	253

7. RECOMMENDED LUBRICANTS

Use only oils listed below or equivalent.

Do not mix different brand oil.

Service point	Kind of fluid	Capacity l (U.S. gal)	Ambient temperature °C (°F)						
			-20 (-4)	-10 (14)	0 (32)	10 (50)	20 (68)	30 (86)	40 (104)
Engine oil pan	Engine oil	38 (10.0)	SAE 30						
			SAE 10W						
			SAE 10W-30						
						SAE 15W-40			
Transmission	Engine oil	43 (11.4)	SAE 10W-30						
						SAE 15W-40			
Axle	UTTO	Front : 58 (15.3) Rear : 58 (15.3)	*Refer to below list						
Hydraulic tank	Hydraulic oil	Tank : 203 (53.6) System : 336 (88.8)	ISO VG 32						
						ISO VG 46			
						ISO VG 68			
Fuel tank	Diesel fuel	450 (118.8)	ASTM D975 NO.1						
						ASTM D975 NO.2			
Fitting (grease nipple)	Grease	As required	NLGI NO.1						
						NLGI NO.2			
Radiator	Mixture of antifreeze and water 50 : 50	65 (17.2)	Ethylene glycol base permanent type						

- SAE : Society of Automotive Engineers
- API : American Petroleum Institute
- ISO : International Organization for Standardization
- NLGI : National Lubricating Grease Institute
- ASTM : American Society of Testing and Material
- UTTO : Universal Tractor Transmission Oil

- * Recommended oil list
- BP TERRAC SUPER TRANSMISSION 10W-30
- CASTROL AGRI TRANS PLUS 10W-30
- MOBILFLUID 426
- SHELL DONAX TD 10W-30
- TOTAL DYNATRANS MPV