

GROUP 6 TROUBLESHOOTING

1. WHEN STARTING SWITCH IS TURNED ON, CLUSTER AND MONITOR LAMP DOES NOT LIGHT UP

- Before carrying out below procedure, check all the related connectors are properly inserted and the fuse [CN-36] No.12 is not blown out and ON/OFF of bulb.
- After checking, connect the disconnected connectors again immediately unless otherwise specified.

	Cause	Remedy
Check voltage between CN-56 (1), CN-57(1) and chassis	Defective cluster	Replace
	Defective monitor	Replace
	Disconnection in wiring harness or poor contact between CN-56 (1), CN-57 (1) and fuse No. 12	Repair or replace (after clean)

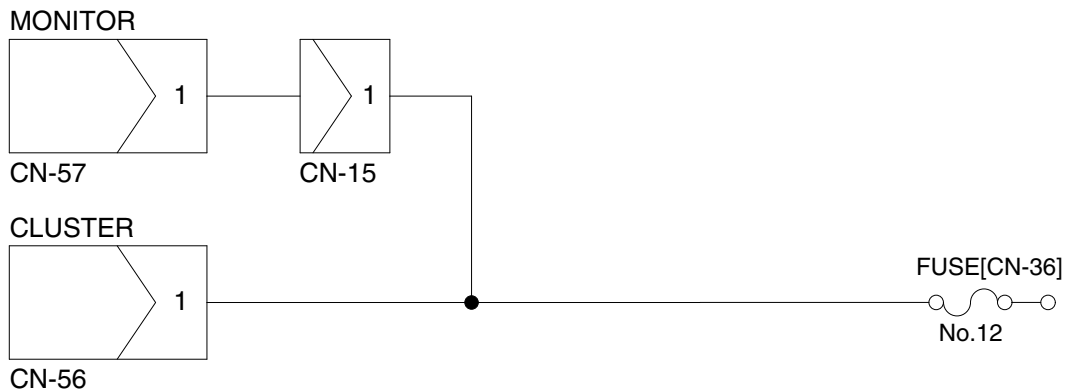

Check voltage

YES	20 ~ 30 V
NO	0 V

7809SU7EL24

2.  **WHEN BATTERY LAMP LIGHTS UP** (engine is started)

- Before carrying out below procedure, check all the related connectors are properly inserted.
- After checking, connect the disconnected connectors again immediately unless otherwise specified.

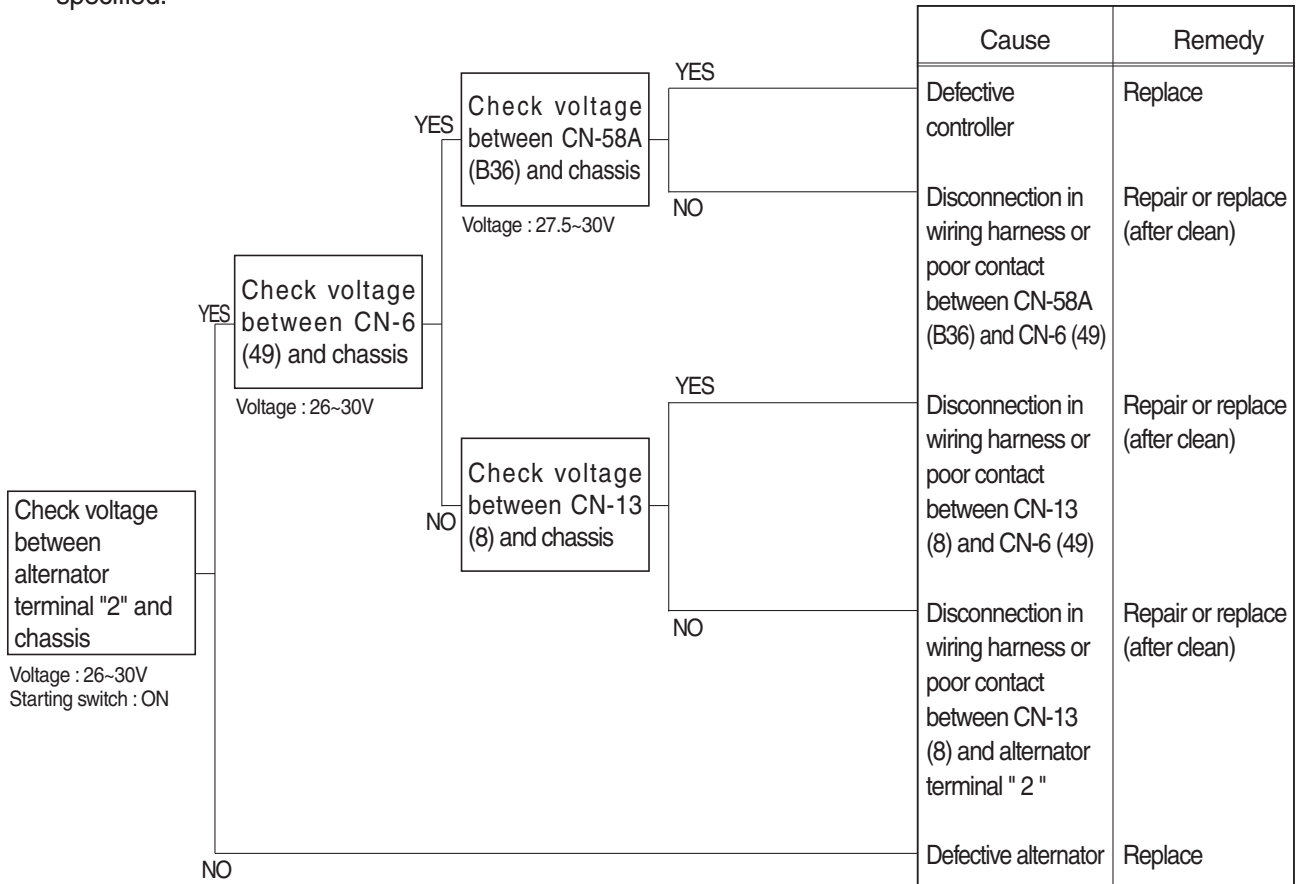

CONTROLLER(MCU)

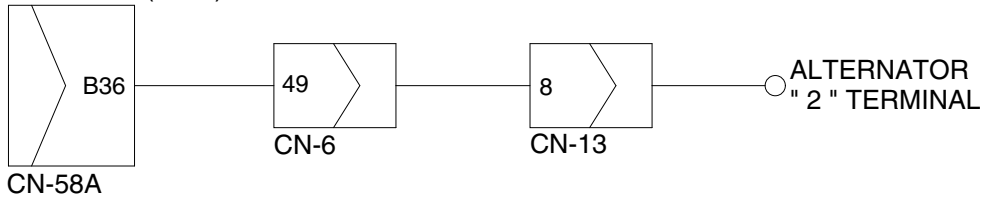

Check valtage

YES	20 ~ 30 V
NO	0 V

7809SU7EL30

3. WHEN PARKING SOLENOID DOES NOT WORK

- Before carrying out below procedure, check all the related connectors are properly inserted and the fuse [CN-36] No.29 is not blown out.
- After checking, connect the disconnected connectors again immediately unless otherwise specified.

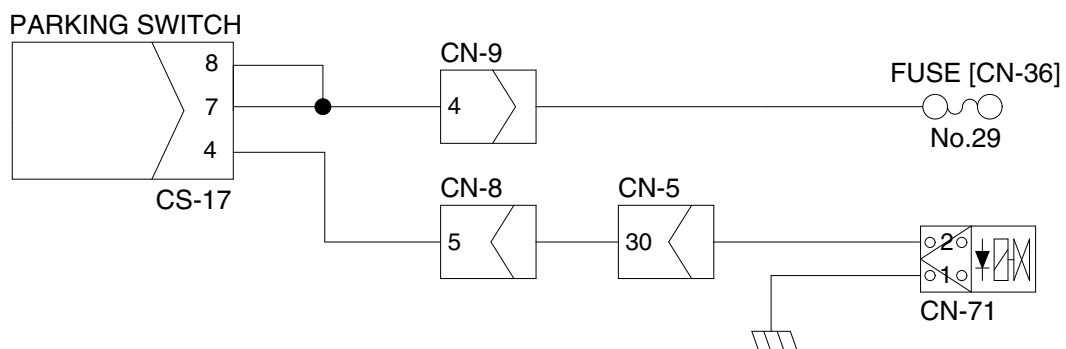
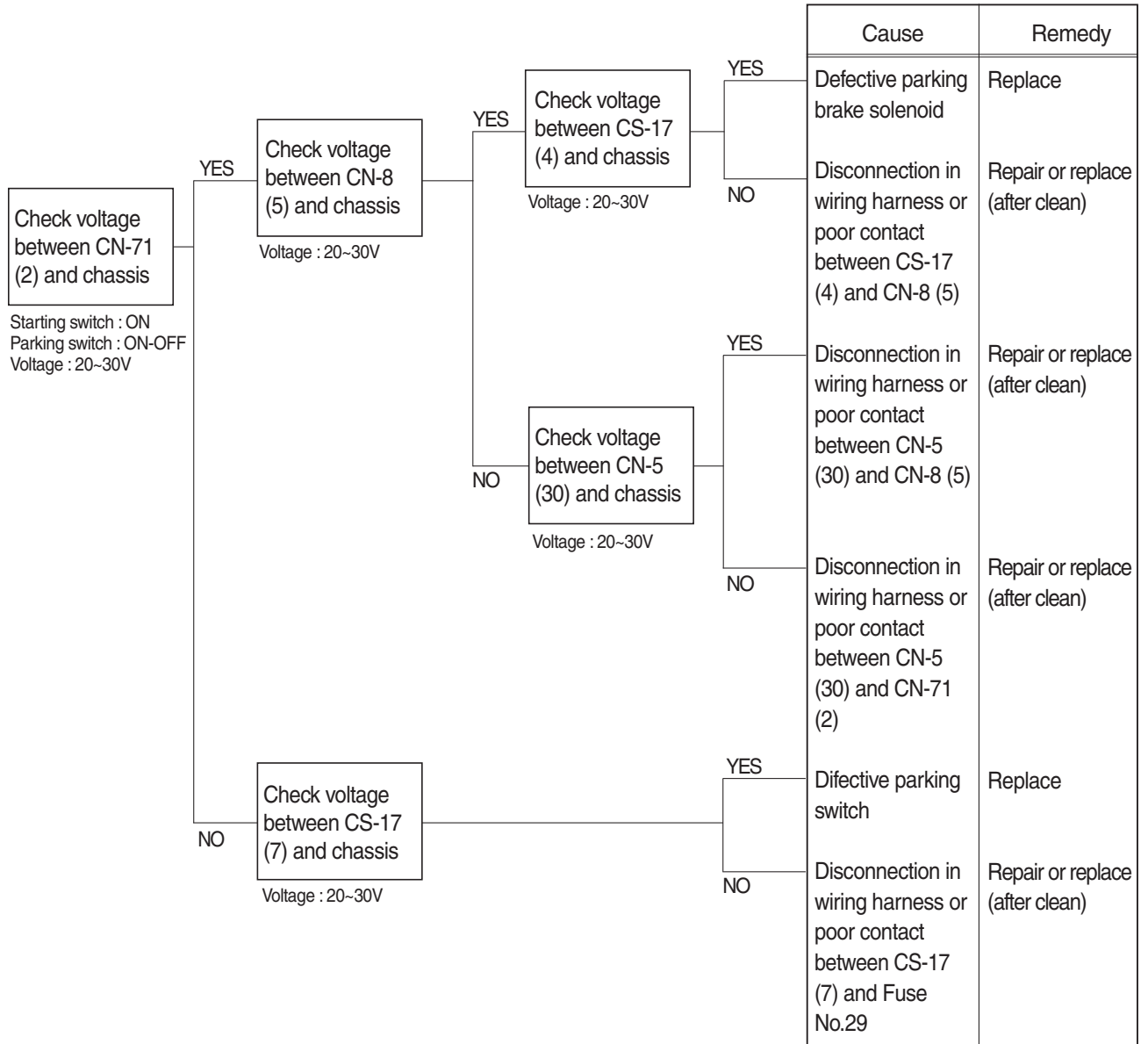

4. TRANSMISSION IS NOT RETURNED TO NEUTRAL WHEN PARKING BRAKE IS APPLIED

- Before carrying out below procedure, check all the related connectors are properly inserted and the fuse [CN-36] No.29 is not blown out.
- After checking, connect the disconnected connectors again immediately unless otherwise specified.

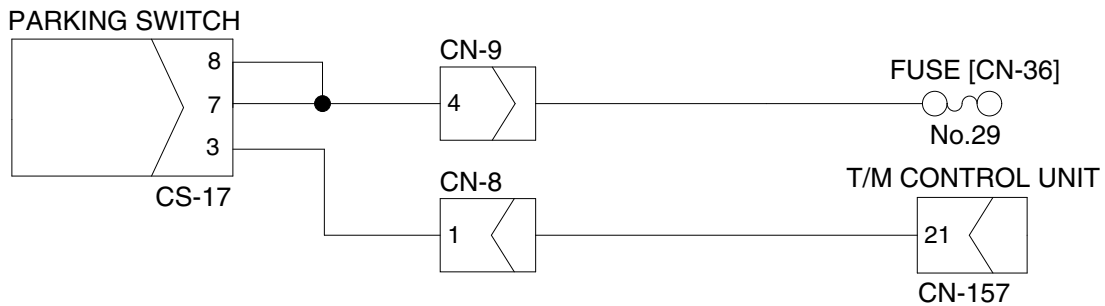
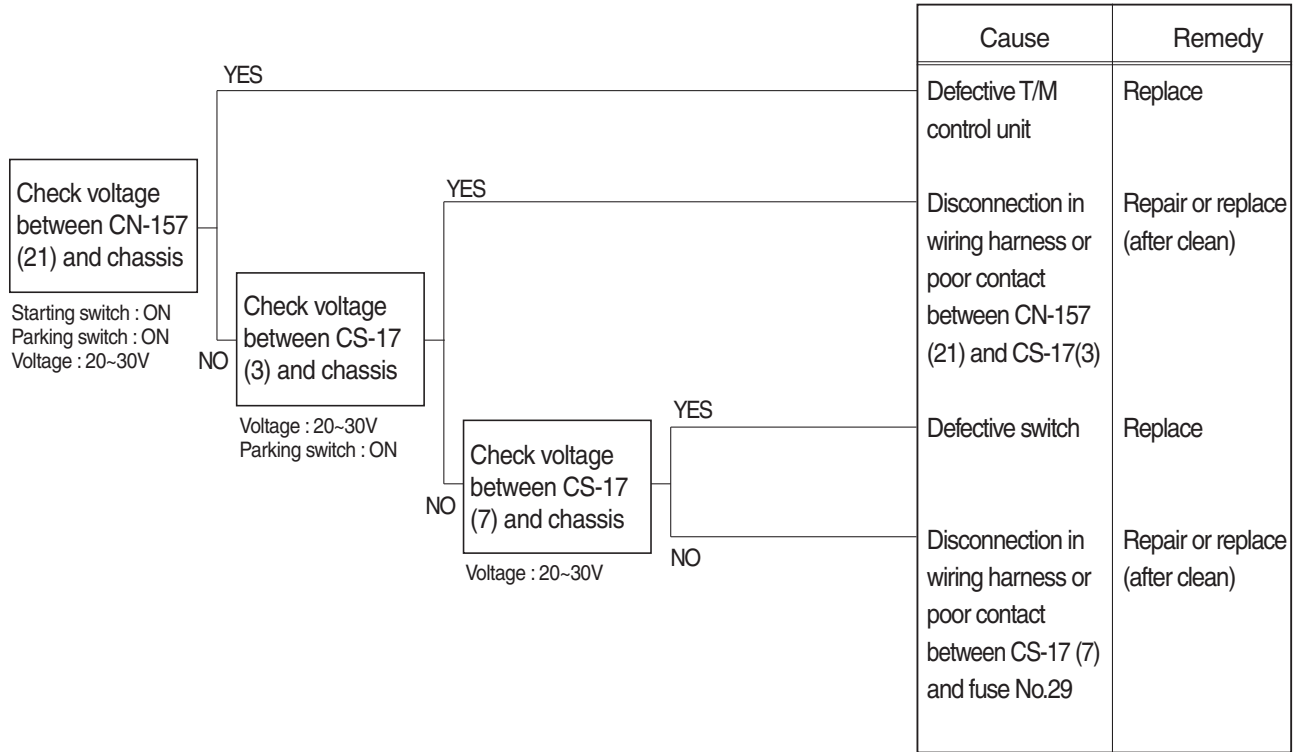

Check resistance

YES	MAX 1 Ω
NO	MIN 1M Ω

7809SU7EL32

5. MACHINE DOES NOT TRAVEL

- Before carrying out below procedure, check all the related connectors are properly inserted and the fuse [CN-36] No.11 (transmission controller) is not blown out.
- After checking, connect the disconnected connectors again immediately unless otherwise specified.
- Wiring diagram : See page 7-17.

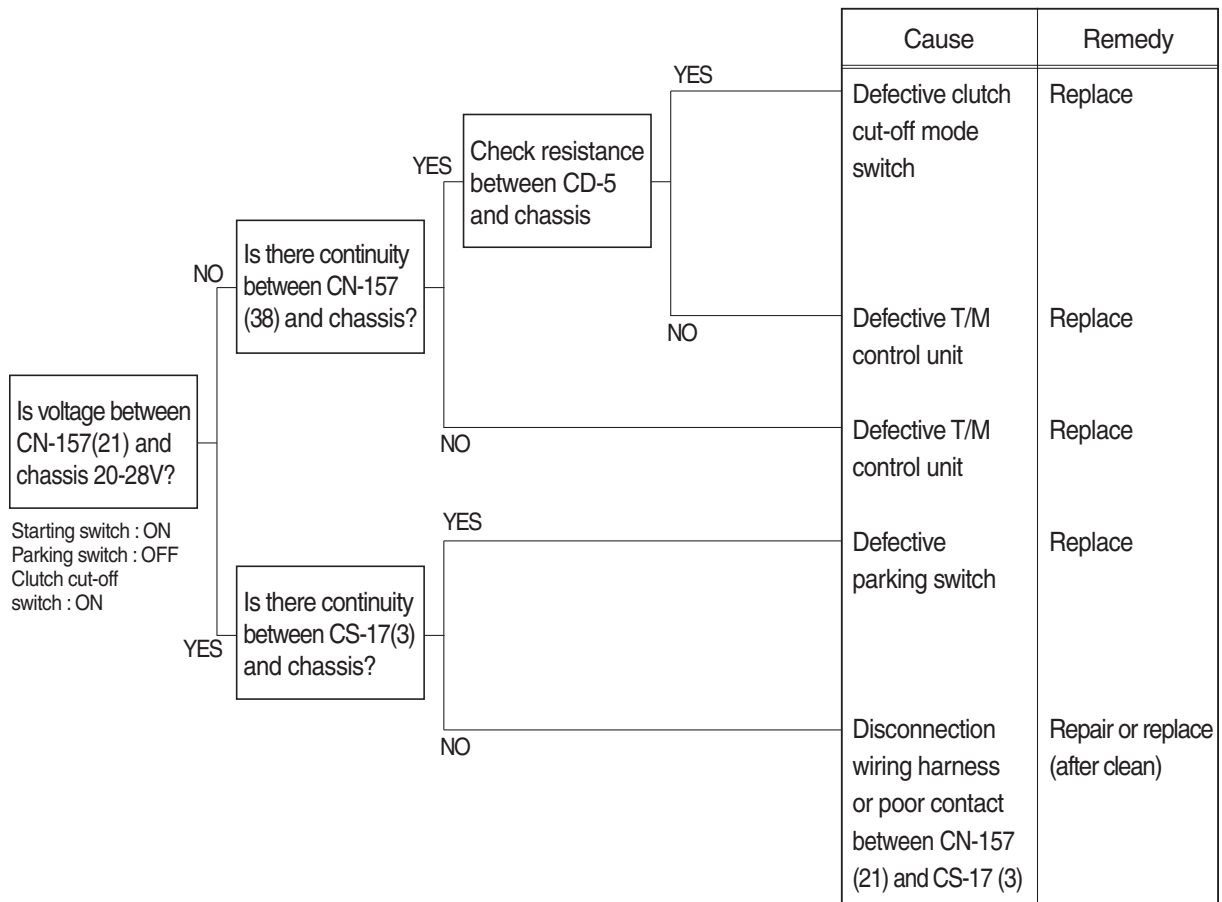

Check resistance

YES	MAX 1 Ω
NO	MIN 1M Ω

6. WHEN STARTING SWITCH IS TURNED ON, WIPER MOTOR DOES NOT OPERATE

- Before carrying out below procedure, check all the related connectors are properly inserted and the fuse No.28 is not blown out.
- After checking, connect the disconnected connectors again immediately unless otherwise specified.

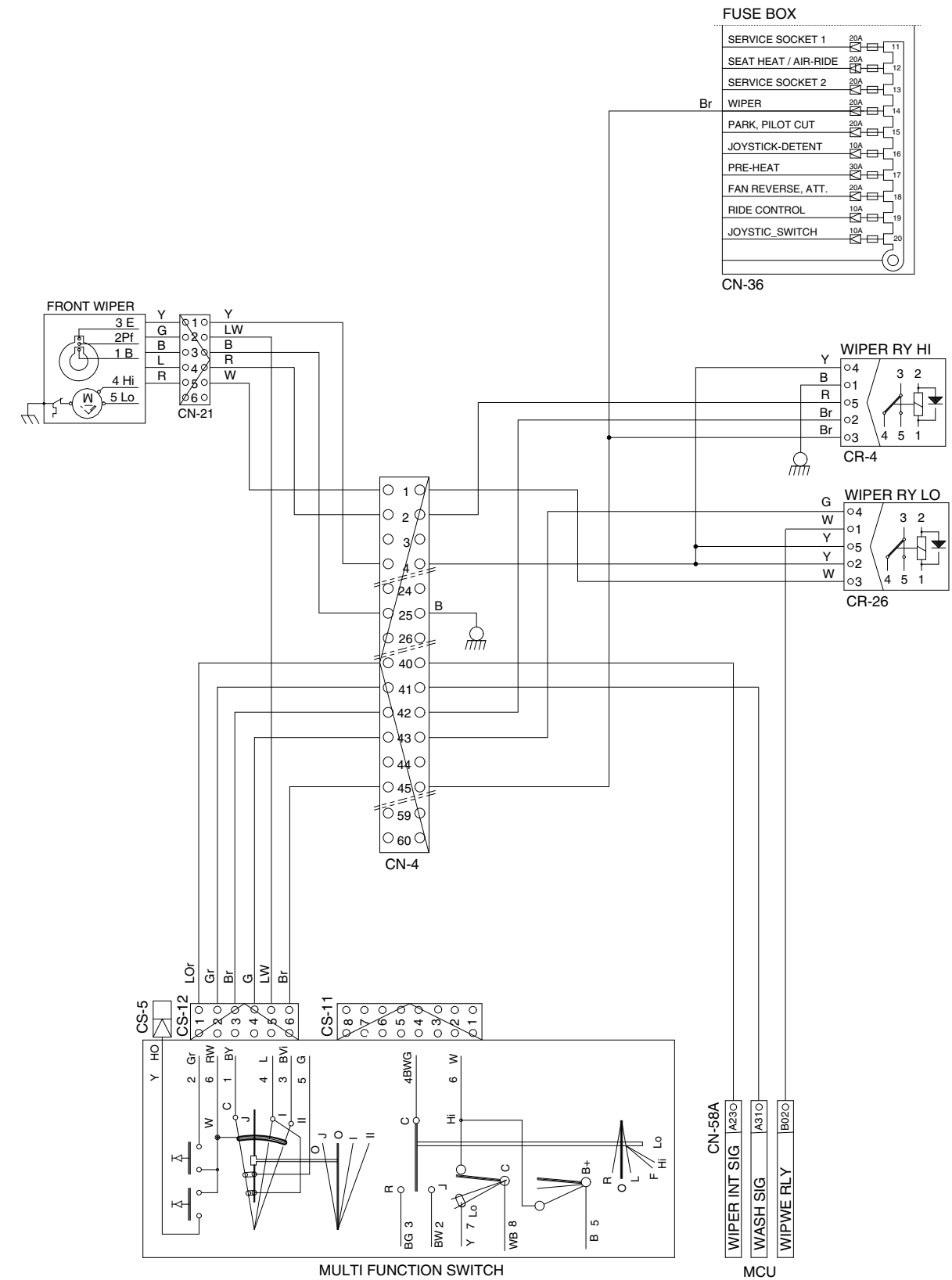
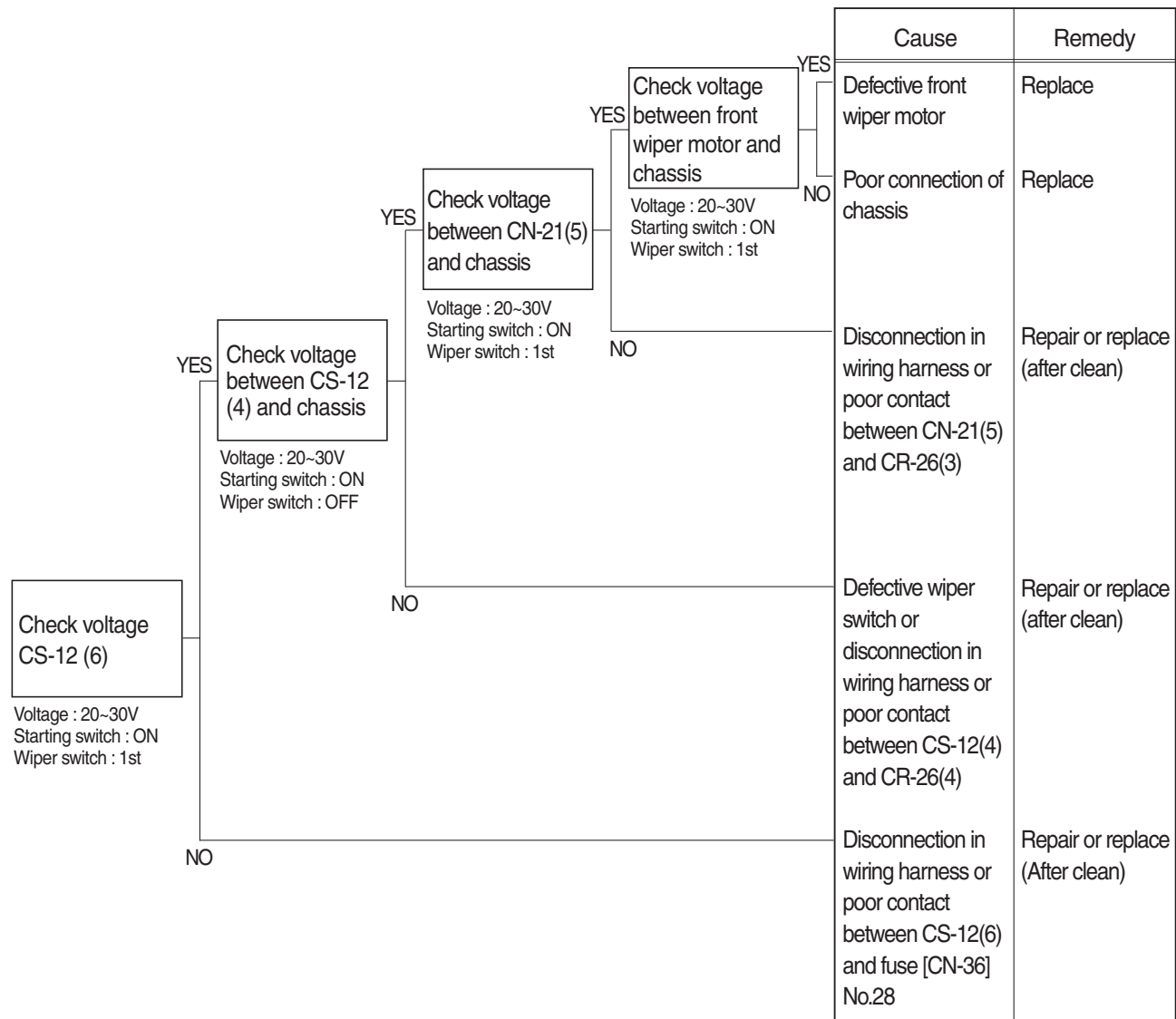

7. WHEN STARTING SWITCH "ON" DOES NOT OPERATE

- Before carrying out below procedure, check all the related connectors are properly inserted and the fuse No.3 is not blown out.
- After checking, connect the disconnected connectors again immediately unless otherwise specified.

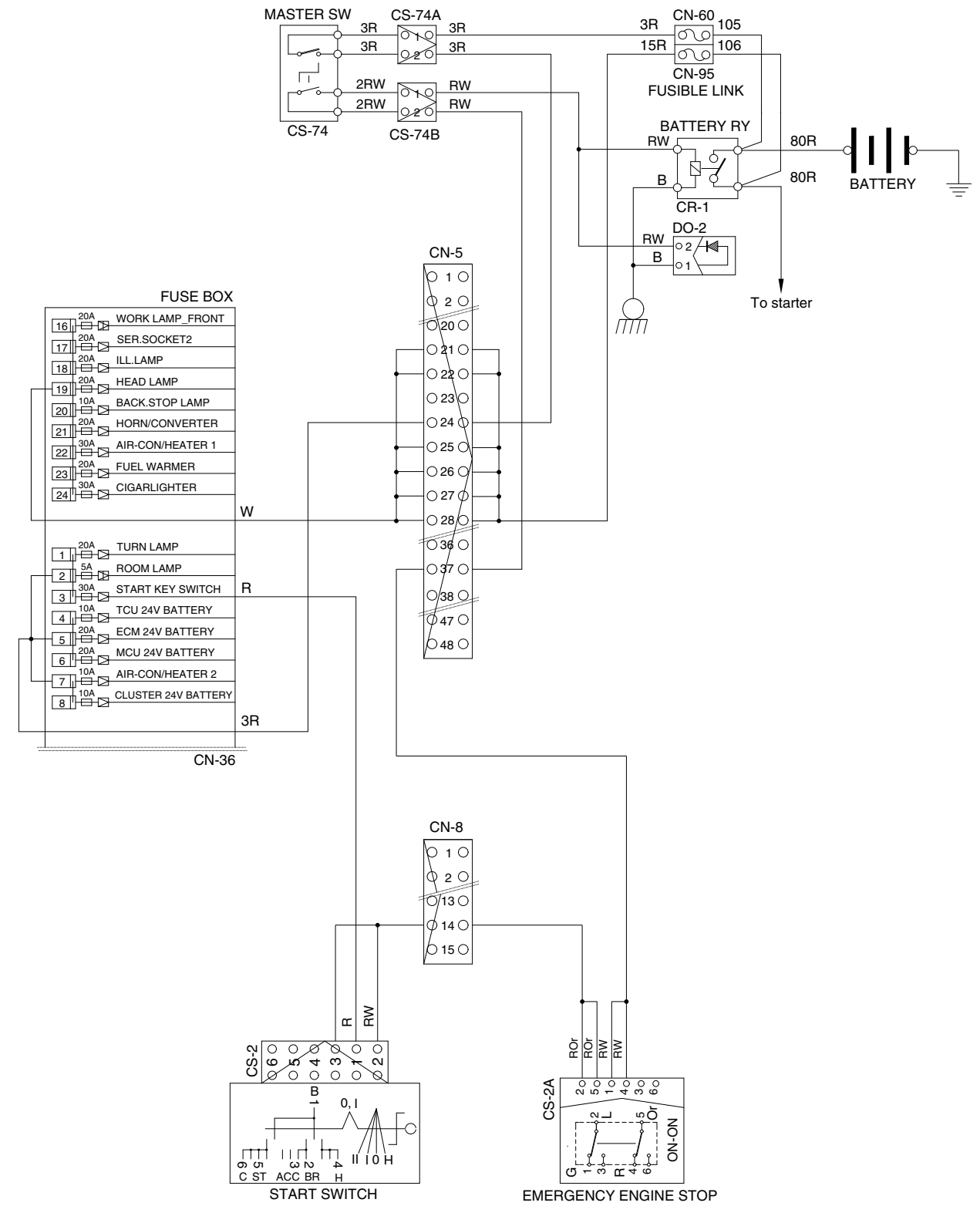
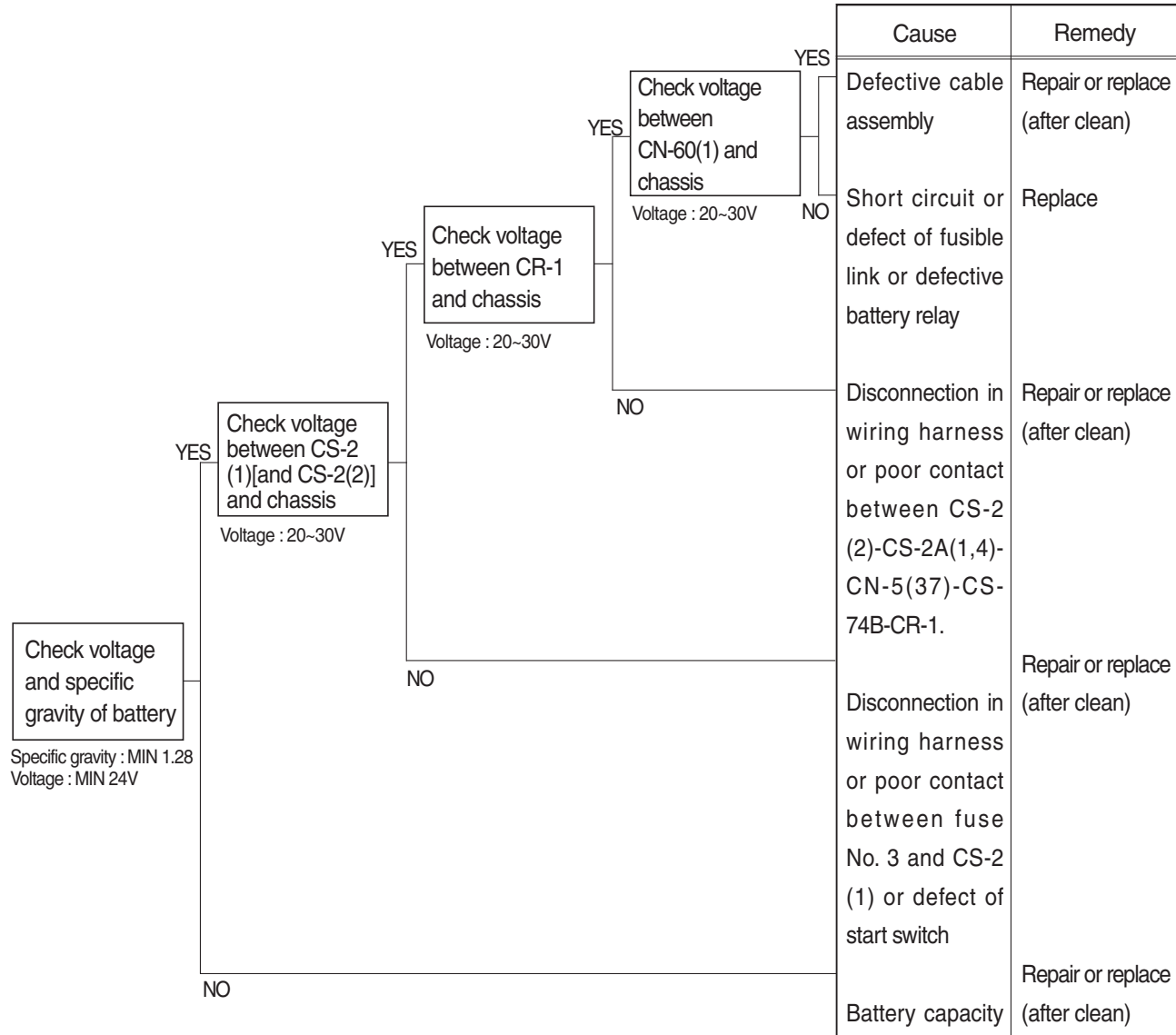

8. WHEN STARTING SWITCH IS TURNED ON, WORK LAMP DOES NOT LIGHTS UP

- Before carrying out below procedure, check all the related connectors are properly inserted, and the fuse [CN-36] No. 16, 27 is not blown out.
- After checking, connect the disconnected connectors again immediately unless otherwise specified.

