

## SECTION 6 WORK EQUIPMENT

Group 1 Structure and Function .....	6-1
Group 2 Operational Checks and Troubleshooting .....	6-31
Group 3 Tests and Adjustments .....	6-42
Group 4 Disassembly and Assembly .....	6-54

# SECTION 6 WORK EQUIPMENT

## GROUP 1 STRUCTURE AND FUNCTION

### 1. HYDRAULIC SYSTEM OUTLINE

The loader hydraulic system is a pilot operated, closed center system which is supplied with flow from the variable displacement piston main hydraulic pump.

The loader system components are :

- Loader pump
- Main control valve
- Bucket cylinder
- Boom cylinders
- Remote control valve (Pilot control valve)
- Safety valve

Flow from the steering pump not used by the steering system leaves the flow amplifier EF port. It flows to the inlet port plate of two section or three section block type main control valve.

The main control valve is load pressure independent flow distribution system which routes flow to the boom, bucket or auxiliary cylinders (not shown) when the respective spools are shifted.

Flow from the loader pump is routed to the main control valve where pump outlet pressure is reduced to pilot circuit pressure. The main control valve flow to the remote control valve.

The remote control valve routed flow to either end of each spool valve section in the main control valve to control spool stroke.

A accumulator mounted on safety valve supplies a secondary pressure source to operated remote control valve so the boom can be lowered if the engine is off.

The return circuit for the main hydraulic system have return filter inside the hydraulic tank. The return filter uses a filter element and a bypass valve. The bypass valve is located in the upside of filter.

## 2. HYDRAULIC CIRCUIT (machine serial No. : ~#0012)

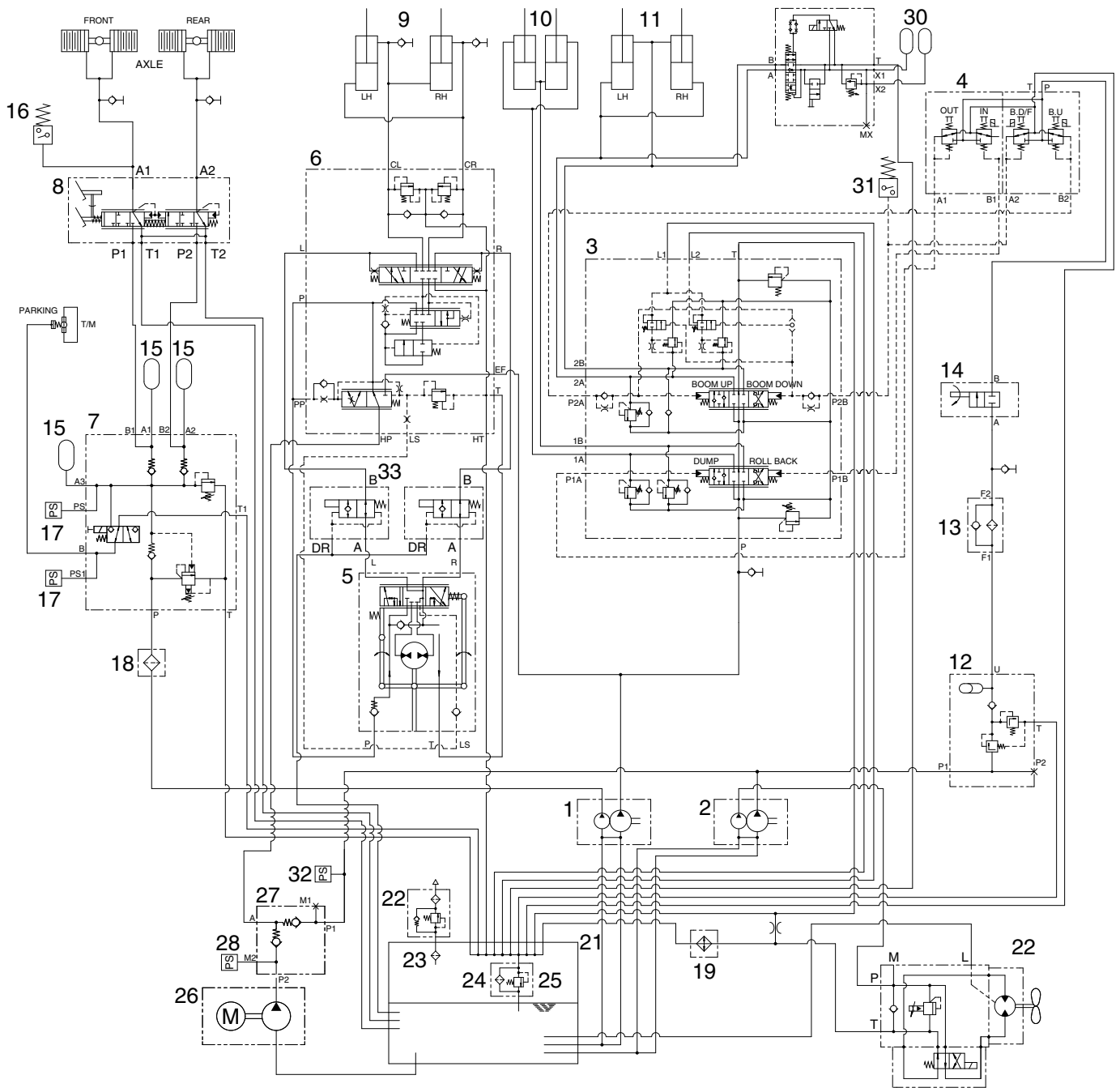

7809SU6WE01

- |    |                      |    |                   |    |                          |
|----|----------------------|----|-------------------|----|--------------------------|
| 1  | Main & brake pump    | 12 | Pilot supply unit | 23 | Strainer                 |
| 2  | Steering & fan pump  | 13 | Line filter       | 24 | Return filter            |
| 3  | Main control valve   | 14 | Safety valve      | 25 | Bypass valve             |
| 4  | Remote control valve | 15 | Accumulator       | 26 | Pump motor (opt)         |
| 5  | Steering unit        | 16 | Pressure switch   | 27 | Check valve block (opt)  |
| 6  | Flow amplifier       | 17 | Pressure sensor   | 28 | Pressure sensor (opt)    |
| 7  | Cut-off valve        | 18 | Line filter       | 29 | Ride control valve (opt) |
| 8  | Brake valve          | 19 | Oil cooler        | 30 | Accumulator (opt)        |
| 9  | Steering cylinder    | 20 | Fan motor         | 31 | Pressure sensor (opt)    |
| 10 | Bucket cylinder      | 21 | Hydraulic tank    | 32 | Pressure sensor          |
| 11 | Boom cylinder        | 22 | Air breather\     | 33 | Stop valve               |

# HYDRAULIC CIRCUIT (machine serial No. : #0013~)

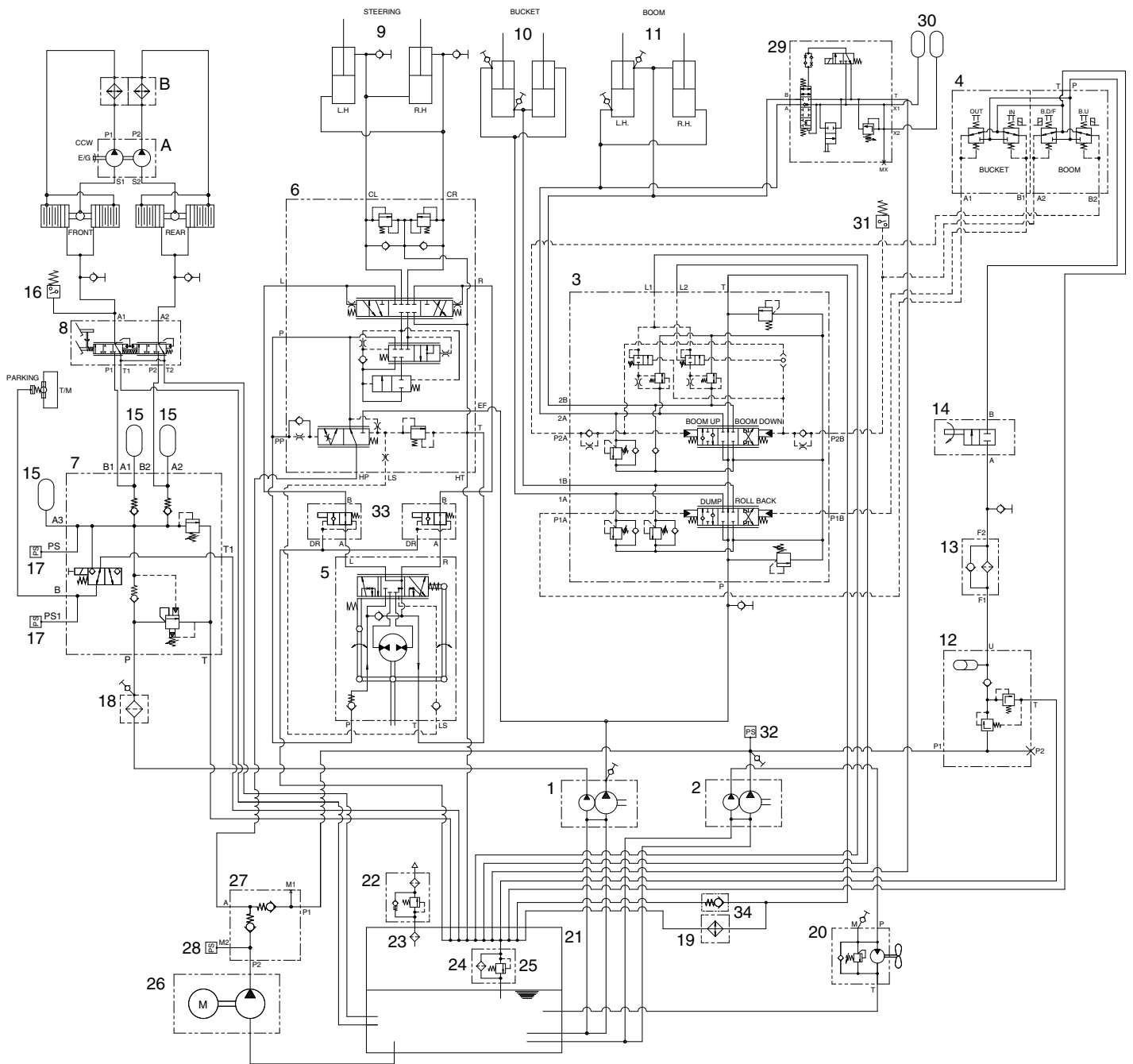

7809SU6WE01A

- |    |                      |    |                   |    |                          |
|----|----------------------|----|-------------------|----|--------------------------|
| 1  | Main & brake pump    | 12 | Pilot supply unit | 23 | Strainer                 |
| 2  | Steering & fan pump  | 13 | Line filter       | 24 | Return filter            |
| 3  | Main control valve   | 14 | Safety valve      | 25 | Bypass valve             |
| 4  | Remote control valve | 15 | Accumulator       | 26 | Pump motor (opt)         |
| 5  | Steering unit        | 16 | Pressure switch   | 27 | Check valve block (opt)  |
| 6  | Flow amplifier       | 17 | Pressure sensor   | 28 | Pressure sensor (opt)    |
| 7  | Cut-off valve        | 18 | Line filter       | 29 | Ride control valve (opt) |
| 8  | Brake valve          | 19 | Oil cooler        | 30 | Accumulator (opt)        |
| 9  | Steering cylinder    | 20 | Fan motor         | 31 | Pressure sensor (opt)    |
| 10 | Bucket cylinder      | 21 | Hydraulic tank    | 32 | Pressure sensor          |
| 11 | Boom cylinder        | 22 | Air breather      | 33 | Stop valve               |
|    |                      |    |                   | 34 | Return check valve       |

### 3. WORK EQUIPMENT HYDRAULIC CIRCUIT

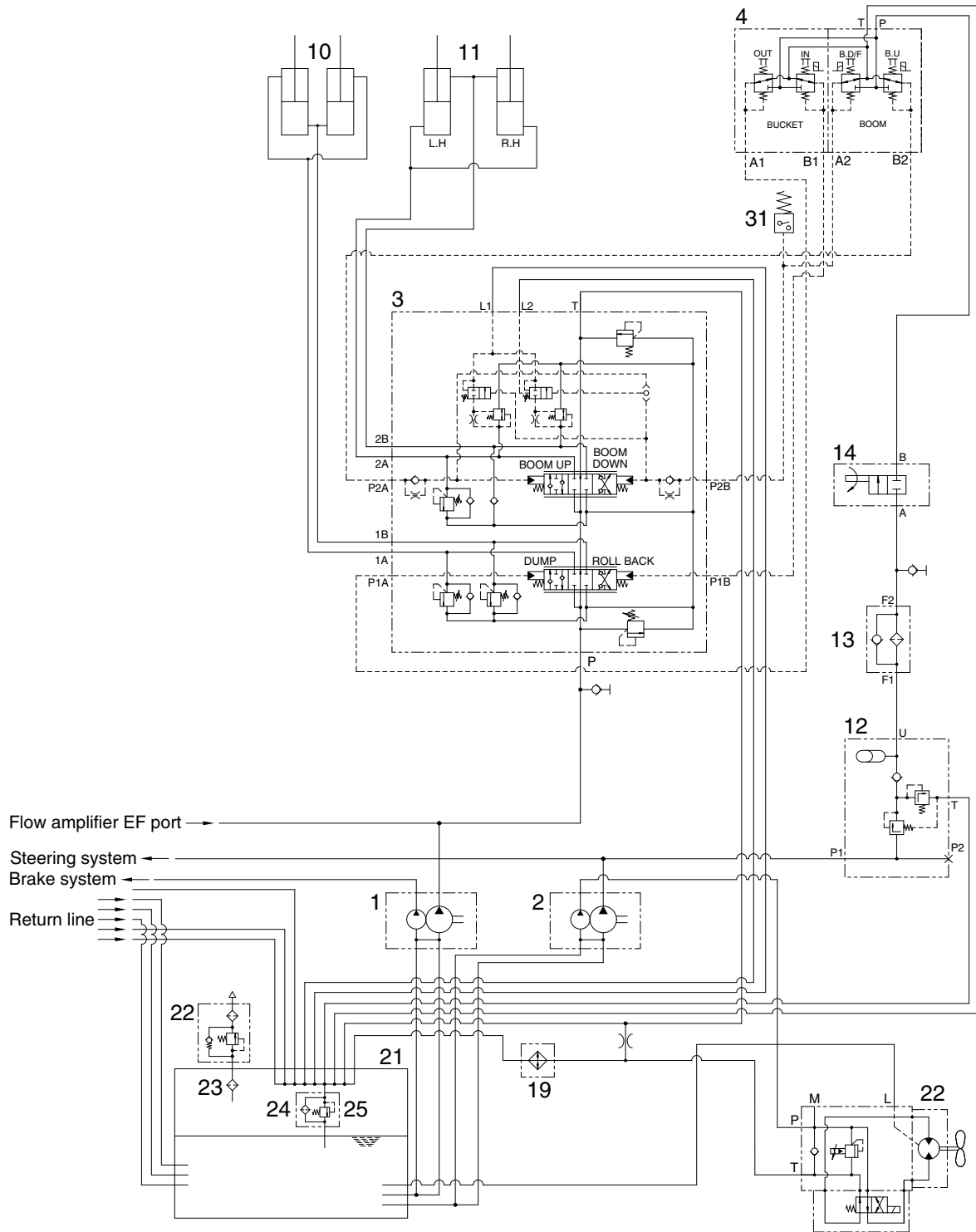

7809SU6WE02

- |    |                      |    |                   |    |                |
|----|----------------------|----|-------------------|----|----------------|
| 1  | Main & breke pump    | 11 | Boom cylinder     | 21 | Hydraulic tank |
| 2  | Steering & fan pump  | 12 | Pilot supply unit | 22 | Air breather   |
| 3  | Main control valve   | 14 | Safety valve      | 23 | Strainer       |
| 4  | Remote control valve | 19 | Oil cooler        | 24 | Return filter  |
| 10 | Bucket cylinder      | 20 | Fan motor         | 25 | Bypass valve   |

## 1) WHEN THE RCV LEVER IS IN THE RAISE POSITION

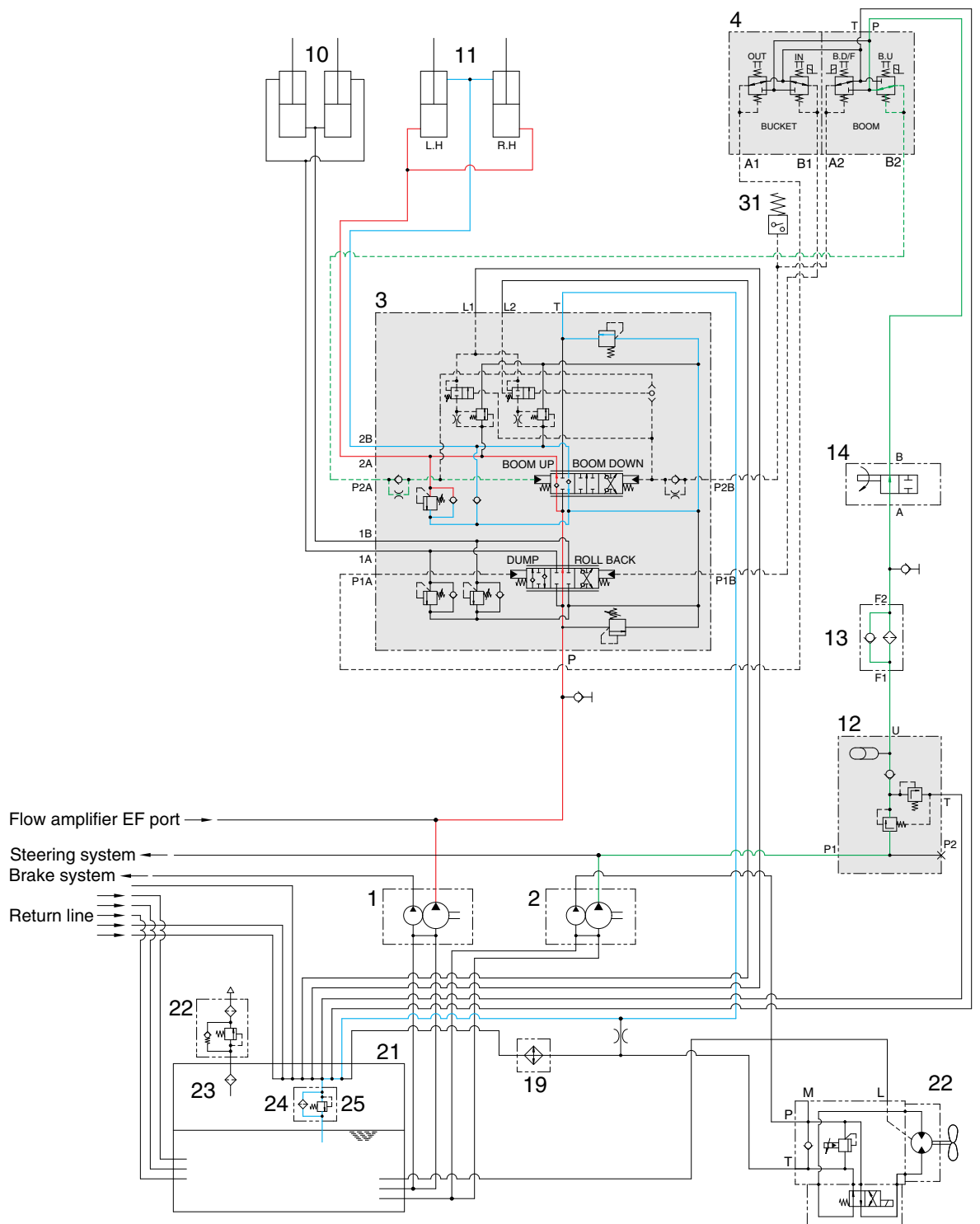

7809SU6WE03

- When the boom RCV lever (4) is pulled back, the boom spool is moved to raise position by pilot oil pressure from port B2 of RCV.
- The oil from main pump (1) flows into main control valve (3) and then goes to the large chamber of boom cylinder (11) by pushing the load check valve of the boom spool through center bypass circuit of the bucket spool.
- The oil from the small chamber of boom cylinder (11) returns to hydraulic oil tank (21) through the boom spool at the same time.
- When this happens, the boom goes up.

## 2) WHEN THE RCV LEVER IS IN THE LOWER POSITION

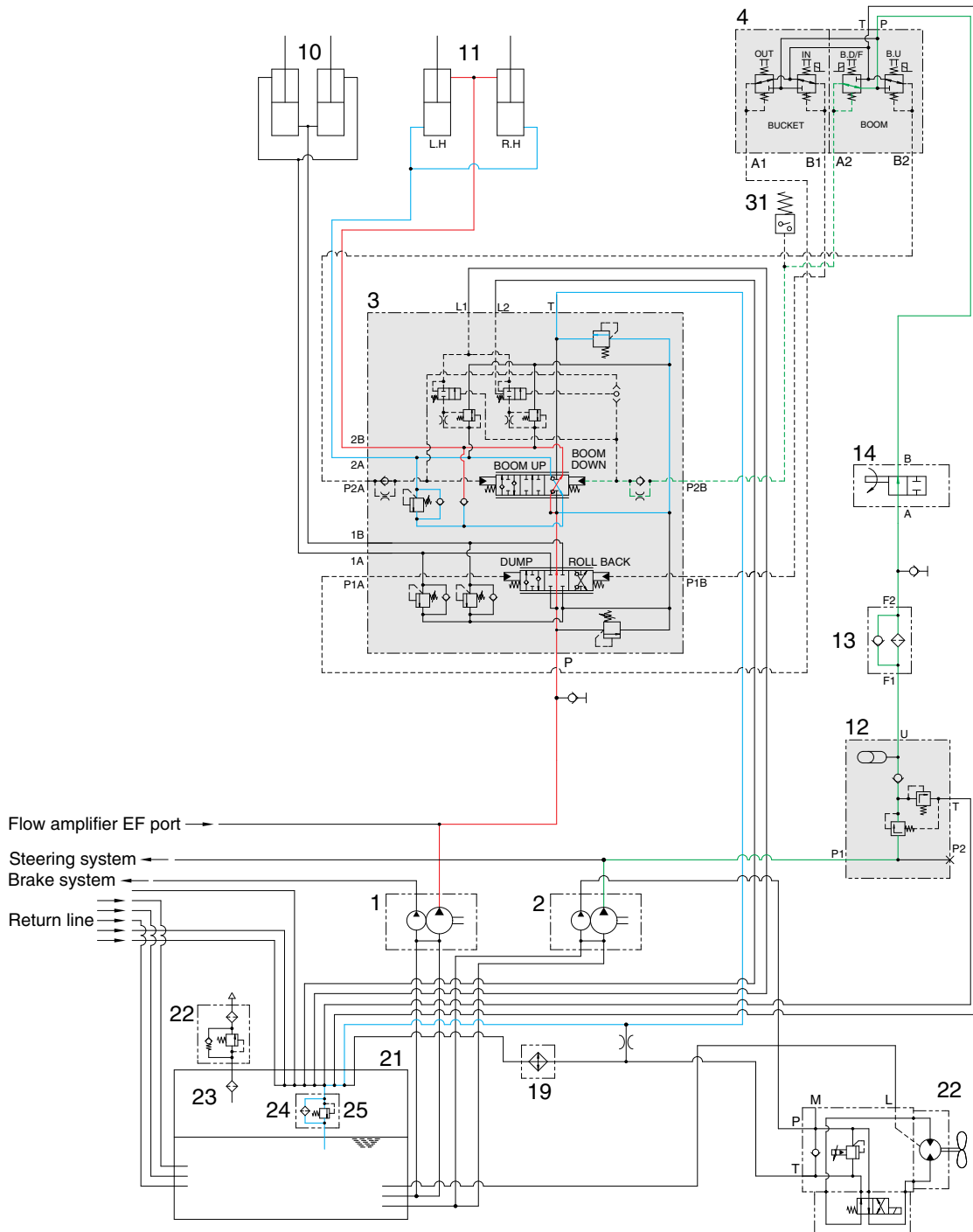

7809SU6WE04

- When the boom RCV lever (4) is pushed forward, the boom spool is moved to lower position by pilot pressure from port A2 of RCV.
- The oil from main pump (1) flows into main control valve and then goes to small chamber of boom cylinder (11) by pushing the load check valve of the boom spool through center bypass circuit of the bucket spool.
- The oil returned from large chamber of boom cylinder (11) returns to hydraulic tank (21) through the boom spool at the same time.
- When the lowering speed of boom is faster, the return oil from the large chamber of boom cylinder combines with the oil from the pump, and flows into the small chamber of the cylinder. This prevents cylinder cavitation by the negative pressure when the pump flow cannot match the boom down speed.

### 3) WHEN THE RCV LEVER IS IN THE FLOAT POSITION

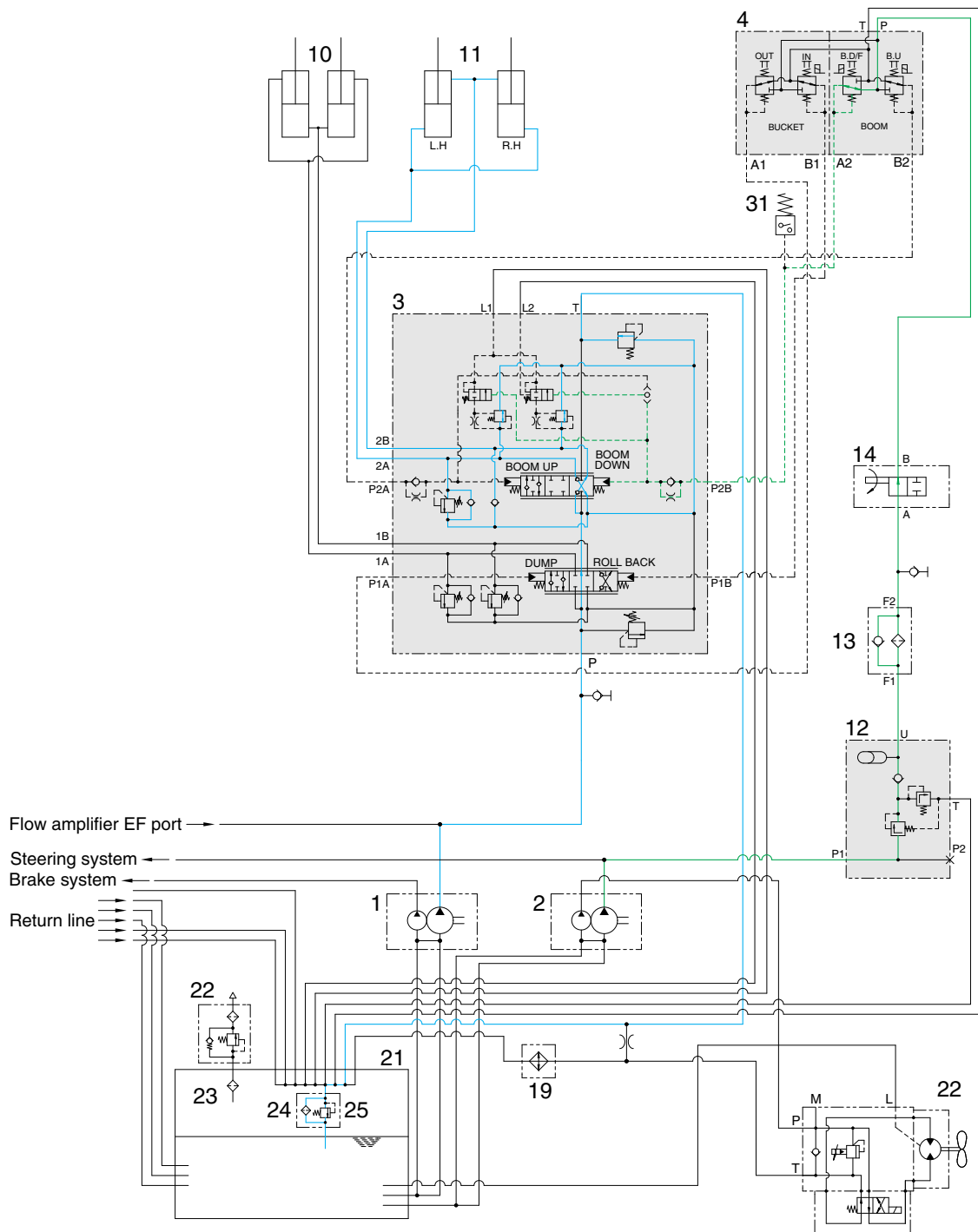

7809SU6WE05

Float is achieved by opening 2 large capacity check valves (A) fitted into the bolt on float check block. These check valves connect each of the boom service ports (2A, 2B) to the tank gallery. Opening of these valves is controlled by pilot pressure from the hydraulic pilot control valve (4). As the hydraulic control lever is selected in the power down direction the pressure at the spool pilot end can on the main valve increases and at some point the spool starts to move progressively through its stroke. This pilot pressure is also connected, internally within the valve, onto a separate pilot spool which controls the opening and closing of the pilot check valves (A). As the pilot pressure operates the main spool up to its maximum stroke the pilot spool then selects at some pressure beyond that and the check valves open, operating a separate connection between the large chamber and small chamber ports and tank.



Subsequent deselection of the control lever allows the pilot spool to deselect, the check valves close, followed by the main spool returning to neutral, all with minimal hysteresis.

On a four position spool, when selecting the spool in one direction, it has to control both power down and float. This means that the spool stroke for the power down part of the stroke is limited and so the metering length is shortened, giving limited control on the service.

Because float is achieved by separate check valves, the whole of the spool selection in that direction can be used for power down and so the metering performance can be maximized.

Because the float is achieved by opening two large capacity check valves, the ability of the valve to 'make up' any cavitation during power down is greatly improved over that of a standard 4 position spool. The original benchmark of no dead time(cavitation in the boom cylinder small chamber) while floating down from full lift height at mid engine speed, has been surpassed. The achievement that has been measured with this product is that there is less than 1 second dead time when floating down from full height at low idle.

#### 4) WHEN THE RCV LEVER IS IN THE DUMP POSITION

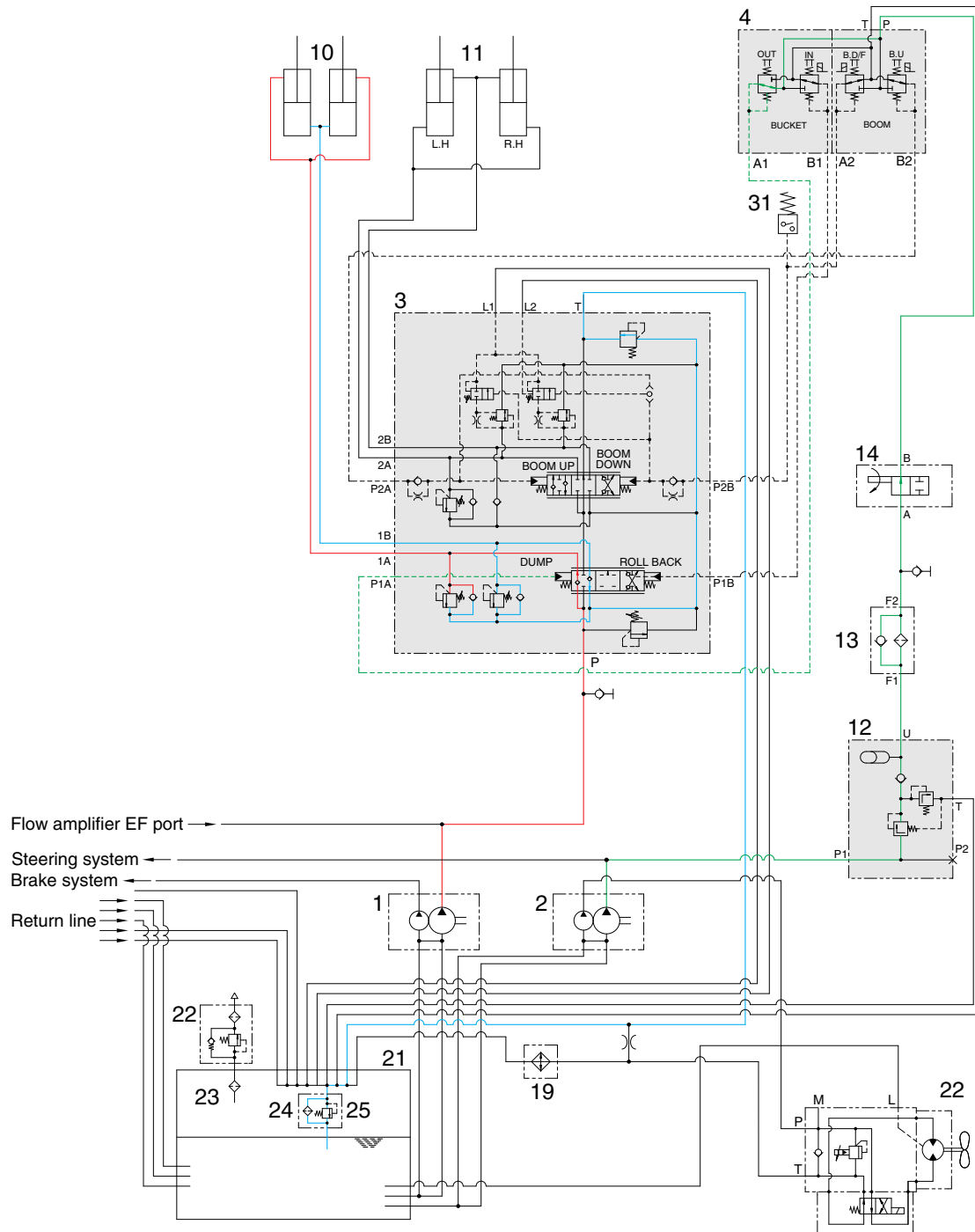

7809SU6WE06

- If the bucket RCV lever (4) is pushed forward, the bucket spool is moved to dump position by pilot oil pressure from port A1 of RCV.
- The oil from main pump (1) flows into main control valve (3) and then goes to the small chamber of bucket cylinder (10) by pushing the load check valve of the bucket spool.
- The oil at the large chamber of bucket cylinder (10) returns to hydraulic tank (21) through the bucket spool.
- When this happens, the bucket is dumped.
- When the dumping speed of bucket is faster, the oil returned from the large chamber of bucket cylinder combines with the oil from the pump, and flows into the small chamber of the cylinder. This prevents cylinder cavitation by the negative pressure when the pump flow cannot match the bucket dump speed.

## 5) WHEN THE RCV LEVER IS IN THE ROLL BACK (retract) POSITION

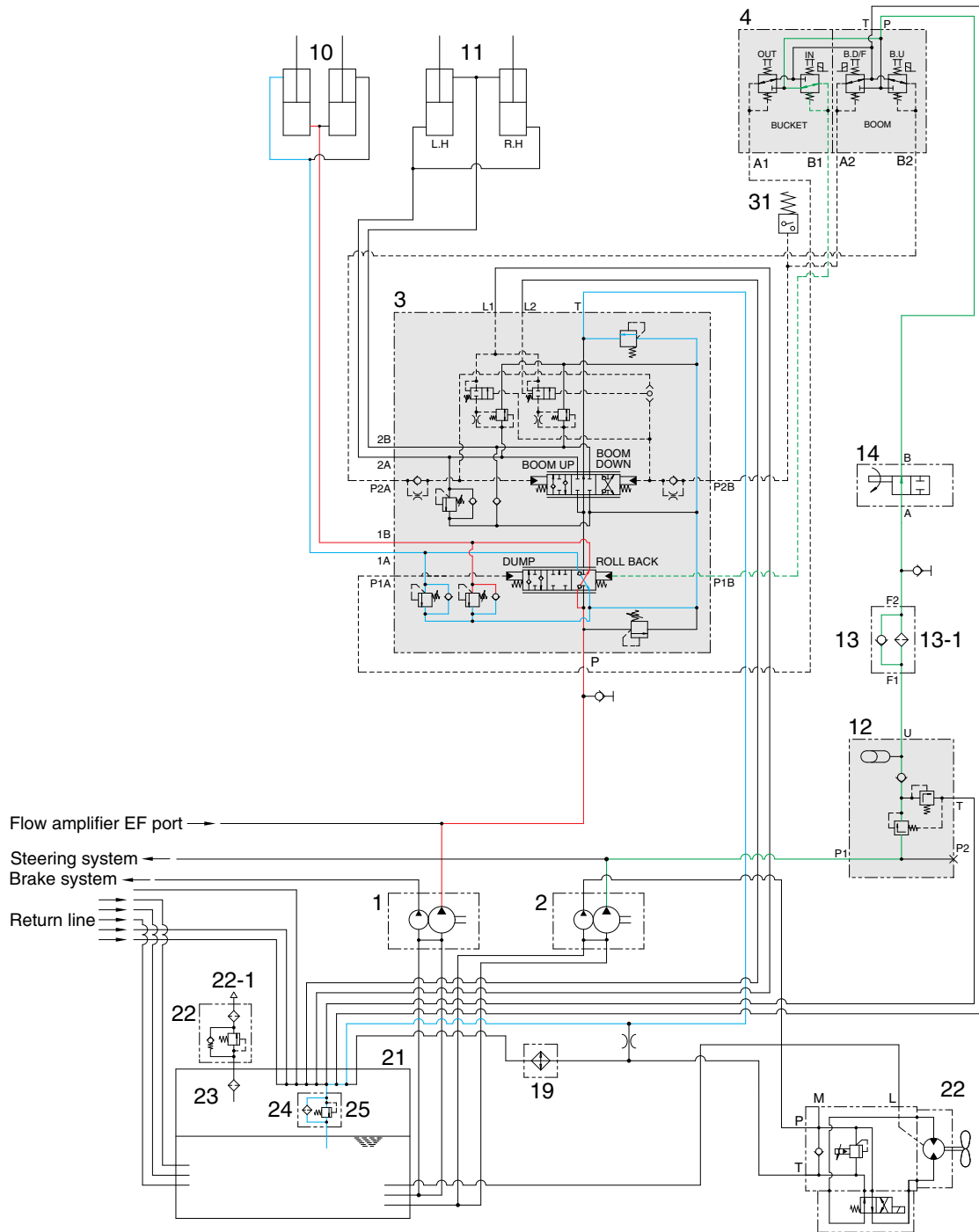

7809SU6WE07

- If the bucket RCV lever (4) is pulled back, the bucket spool is moved to roll back position by pilot oil pressure from port B1 of RCV.
- The oil from main pump (1) flows into main control valve (3) and then goes to the large chamber of bucket cylinder by pushing the load check valve of the bucket spool.
- The oil at the chamber of bucket cylinder (10) returns to hydraulic tank (21) through the bucket spool.
- When this happens, the bucket roll back.
- When the rolling speed of bucket is faster, the return oil from the small chamber of bucket cylinder combines with the oil from the pump, and flows into the large chamber of the cylinder. This prevents cylinder cavitation by the negative pressure when the pump flow cannot match the bucket rolling speed.

## 4. MAIN PUMP (+BRAKE PUMP)

### 1) STRUCTURE

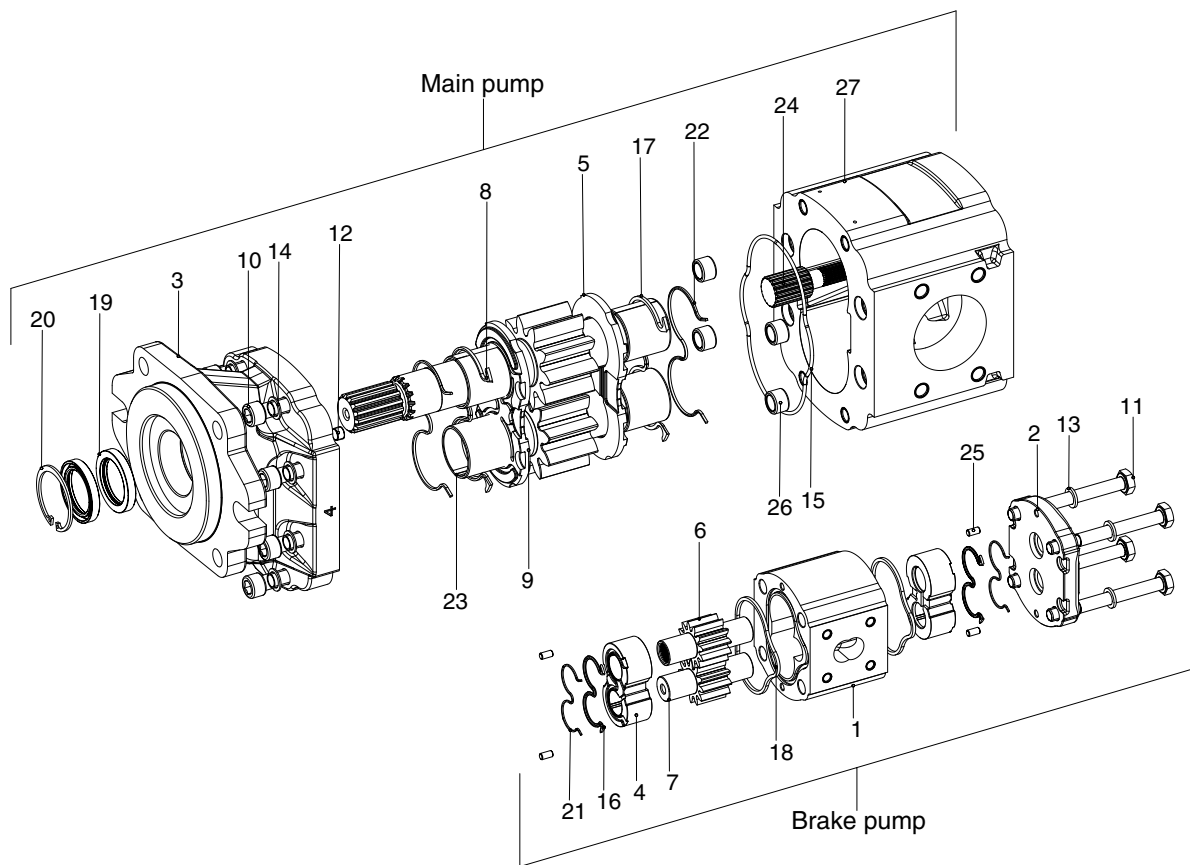

7809SU4BS07

1	Body	11	Screw	21	Shaft seal
2	Rear cover	12	Screw	22	Ring
3	Front cover	13	Nut	23	Ring
4	Thrust plate	14	Screw	24	Ring
5	Bushing	15	Washer	25	Sleeve bearing
6	Drive gear	16	Washer	26	Hub
7	Driven gear	17	Seal	27	Dowel pin
8	Drive shaft	18	Seal	28	Steel bushing
9	Driven gear	19	Seal	29	Housing
10	Stud bolt	20	Seal		

This main pump have a maximum delivery pressure of 210 kgf/cm<sup>2</sup>. (Brake pump : 150 kgf/cm<sup>2</sup>)

The pressure loaded type gear pump is designed so that the clearance between the gear and the bushing can be automatically adjusted according to the delivery pressure. Therefore, the oil leakage from the bushing is less than that in the case of the fixed bushing type under a high discharge pressure. Consequently, no significant reduction of the pump delivery occurs, even when the pump is operated under pressure.

## 2) PRINCIPLE OF OPERATION

### (1) Mechanism for delivering oil

The drawing at right shows the operational principle of an external gear pump in which two gears are rotating in mesh.

The oil entering through the suction port is trapped in the space between two gear teeth, and is delivered to the discharge port as the gear rotates.

Except for the oil at the bottom of the gear teeth, the oil trapped between the gear teeth, is prevented from returning to the suction side with the gears in mesh.

Since the gears are constantly delivering oil, the oil delivered to the discharge port is forced out of the port.

The amount of discharge increases with the speed of rotation of the gear.

If there is no resistance in the oil passage into which the discharged oil flows, the oil merely flows through the passage, producing no increase in pressure.

If however, the oil passage is blocked with something like a hydraulic cylinder, there will be no other place for the oil to flow, so the oil pressure will rise. But the pressure which rises in this way will never go higher, once the hydraulic cylinder piston starts moving because of the oil pressure. As described earlier, the pump produces the oil flow, but not the oil pressure. We can therefore conclude that pressure is a consequence of load.

In other words, the pressure depends on a counterpart.

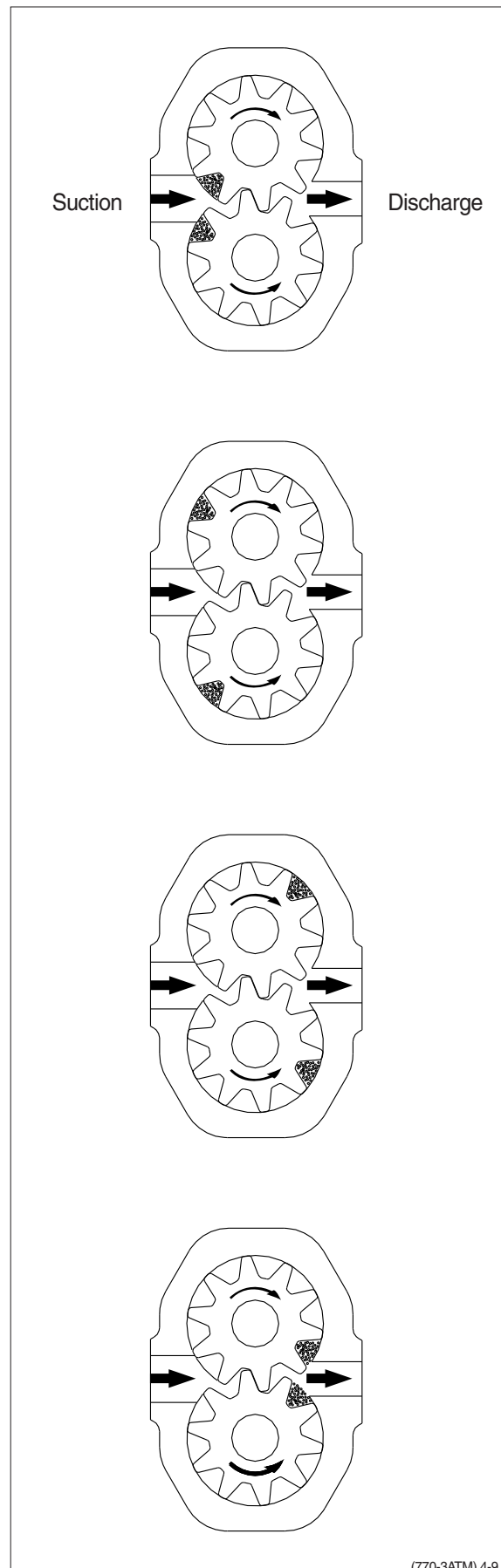

## (2) Internal oil leakage

Oil leaks from a place under higher pressure to a place under lower pressure, provided that a gap or a clearance exists in between.

In the gear pump, small clearances are provided between the gear and the case and between the gear and the side plate to allow the oil to leak out and to serve as a lubricant so that the pump will be protected from seizure and binding.

The drawing at right shows how the leaked oil flows in the pump. As such, there is always oil leakage in the pump from the discharge side (under higher pressure) to the suction side. The delivery of the pump is reduced by an amount equal to the pump discharge.

In addition, the delivery of the pump will also decrease as the amount of oil leakage increases because of expanded radial clearance resulting from the wear of pump parts, the lower oil viscosity resulting from increases in the oil temperature, and the initial use of low viscosity oil.

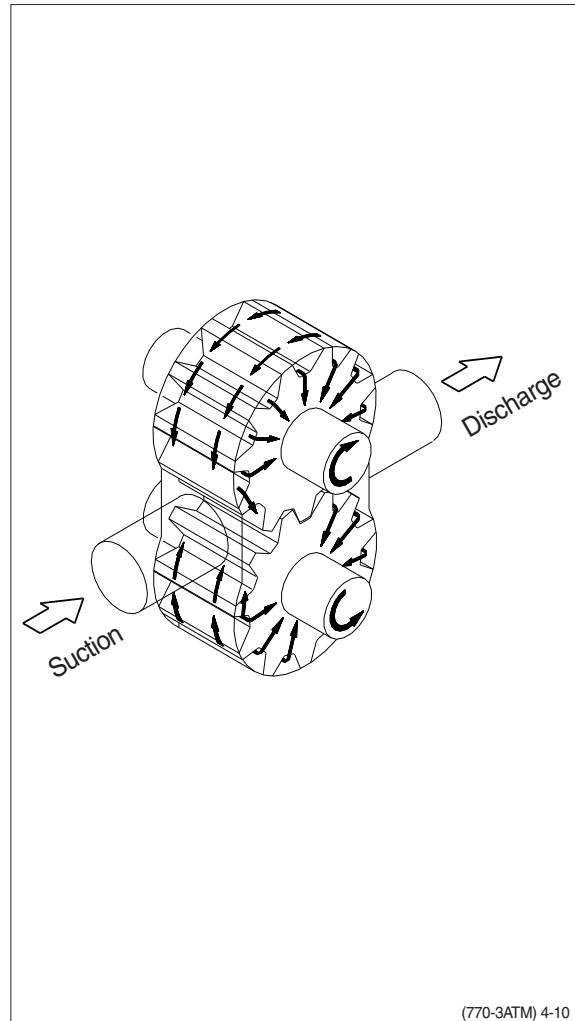

### (3) Forces acting on the gear

The gear, whose outer surface is subjected to oil pressure, receives forces jointing towards its center.

Due to the action of the delivery pressure, the oil pressure is higher on the delivery side of the pump, and due to suction pressure, is lower on the suction side.

In the intermediate section, the pressure will gradually lower as the position moves from the delivery side to the suction side.

This phenomenon is shown in the drawing at right.

In addition, the gears in mesh will receive interacting forces.

These forces pushing the gears toward the suction side are received by the bearings. Since the gears are pressed toward the suction side by these forces, the radial clearance becomes smaller on the suction side in the case. In some pumps, the clearance may become zero, thus allowing the gear teeth and the case to come into light contact.

For this reason, an excessive increase in the delivery pressure must be avoided, since it will produce a large force which will act on the gears, placing an overload on the bearings, and resulting in a shortened service life of the bearing or interference of the gear with the case.

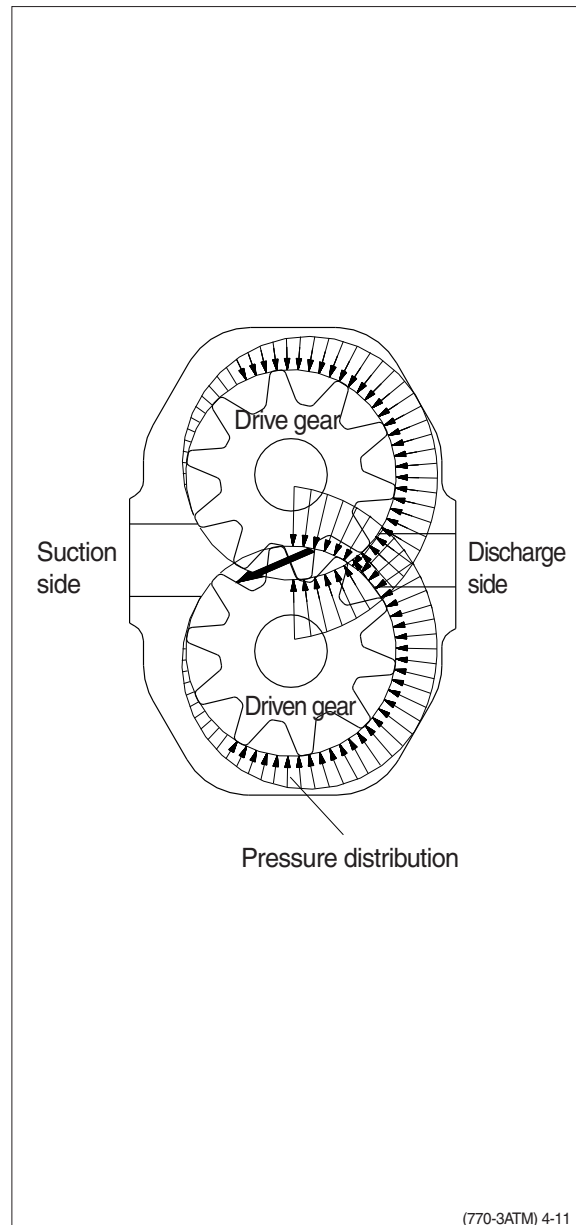

## 5. MAIN CONTROL VALVE

### 1) STRUCTURE

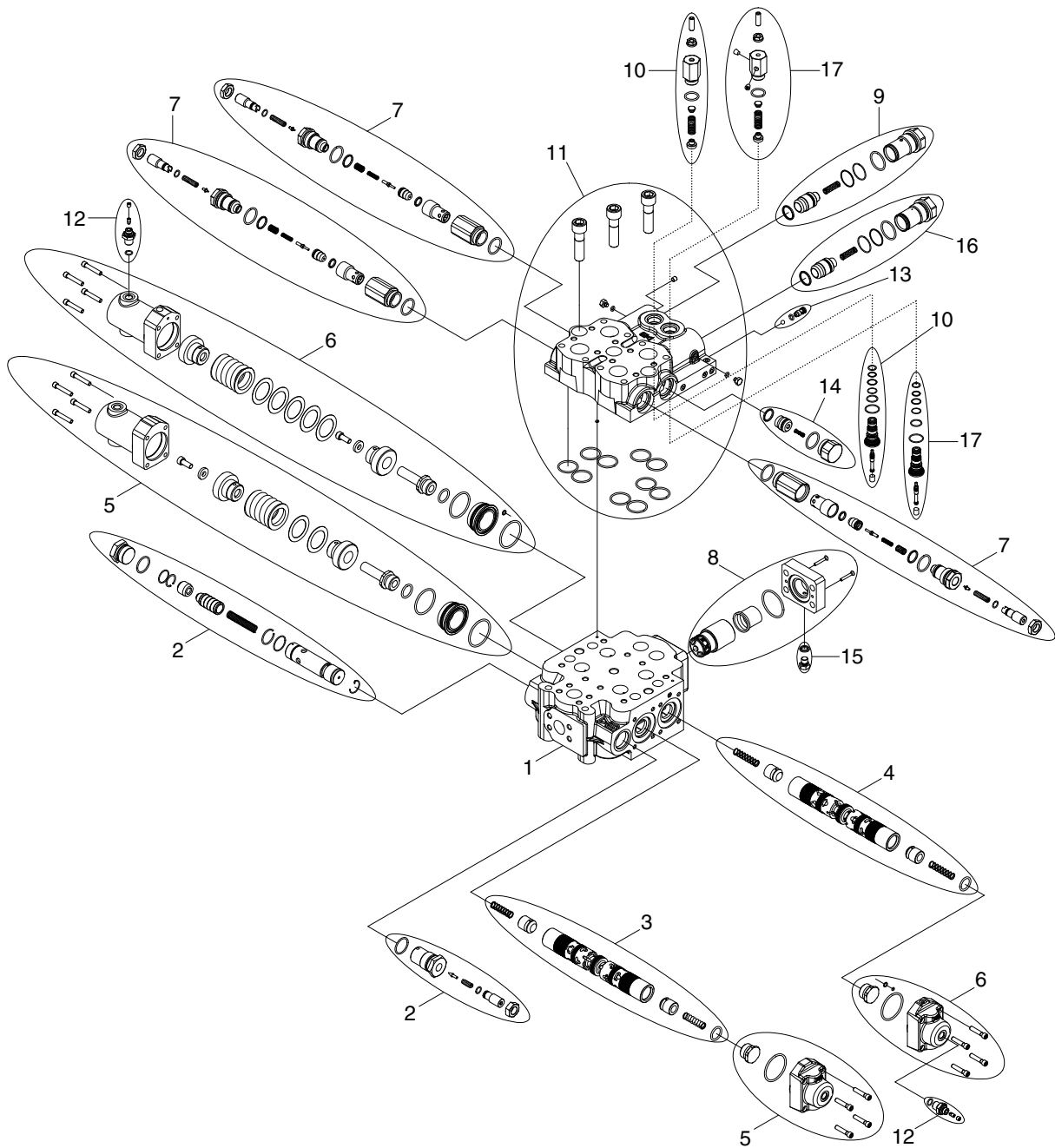

7707WE30

- |   |  |    |   |
|---|--|----|---|
| 1 | Housing group                                | 10 | Pilot valve assembly                      |
| 2 | Main relief valve assembly                   | 11 | Pilot operated float check block assembly |
| 3 | Double acting spool(Bucket)                  | 12 | Adaptor & check valve                     |
| 4 | Double acting spool(Boom)                    | 13 | Shuttle valve assembly                    |
| 5 | Bucket spool centering                       | 14 | Anti-cavitation check valve assembly      |
| 6 | Boom spool centering                         | 15 | 1/4" BSPP plug                            |
| 7 | Combined overload & anti-cavitation assembly | 16 | Check valve assembly                      |
| 8 | Back pressure valve                          | 17 | Pilot valve assembly                      |
| 9 | Check valve assembly                         |    |   |



# STRUCTURE

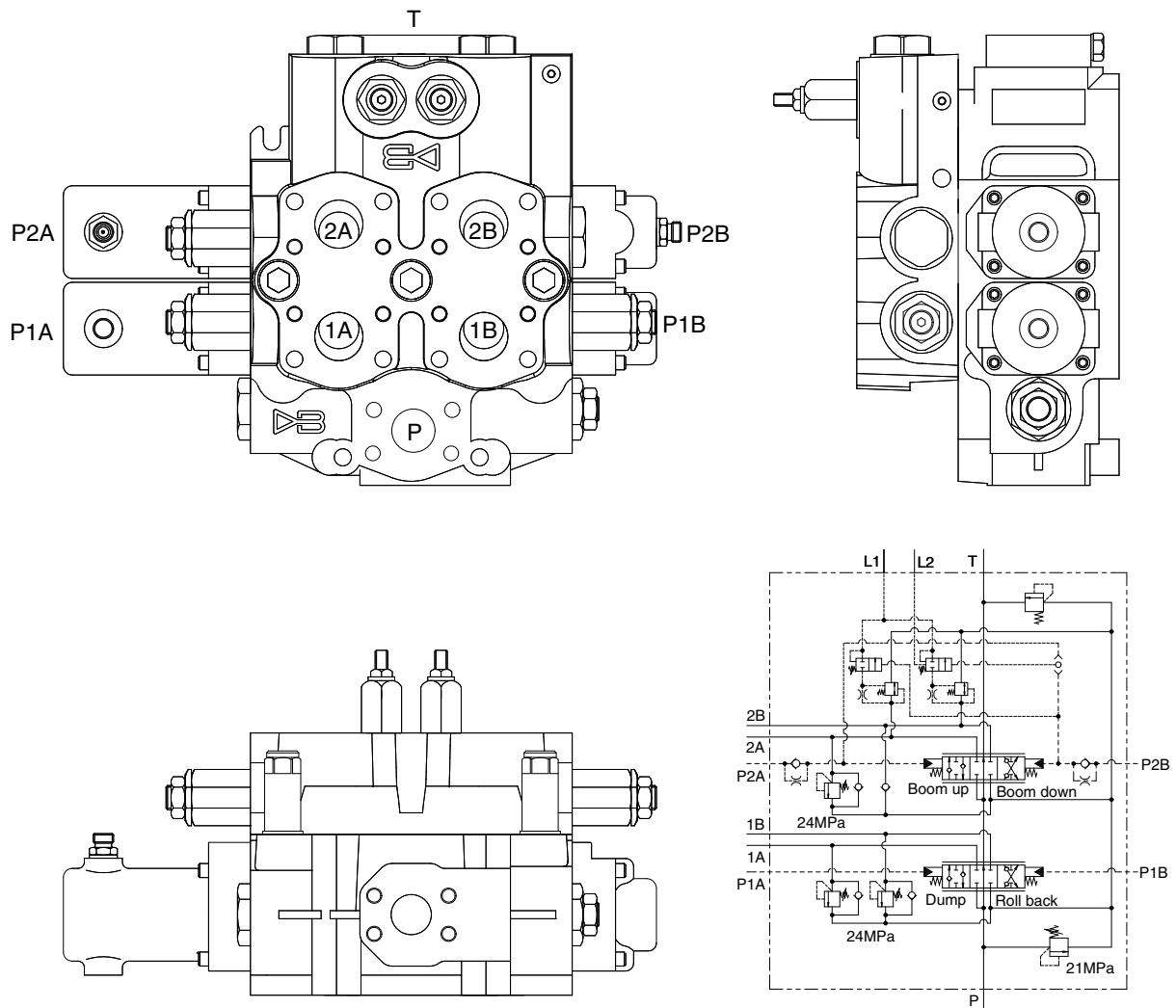

7809SUWE71

Port	Port name	Port size
P	From main pump	1-1/4" SAE split flange
T	To hydraulic tank	2" SAE split flange
1A, 1B	To bucket cylinder port	1-1/2" split flange
2A, 2B	To boom cylinder port	1-1/2" split flange
P2A, P2B	Boom pilot port	PF 3/8" fitting
P1A, P1B	Bucket pilot port	9/16" -18 UNF

## 2) BOOM SECTION OPERATION

### (1) Spool in neutral

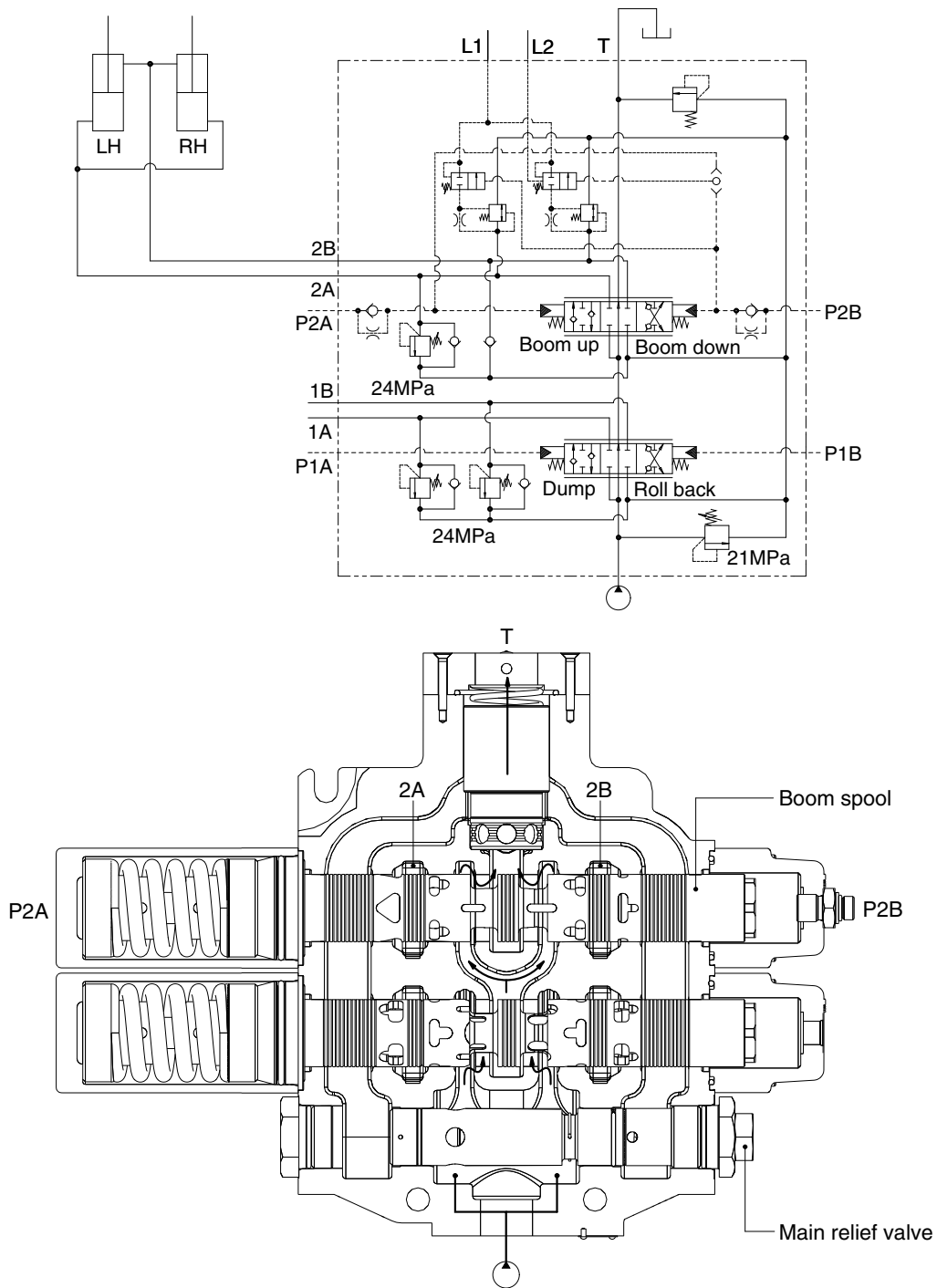

7809SU6WE72

If the remote control valve is not operated, the oil supplied from the pump port passes through the neutral passage to the low pressure passage at the outlet section, and then returns to the tank port.

## (2) Boom raise position

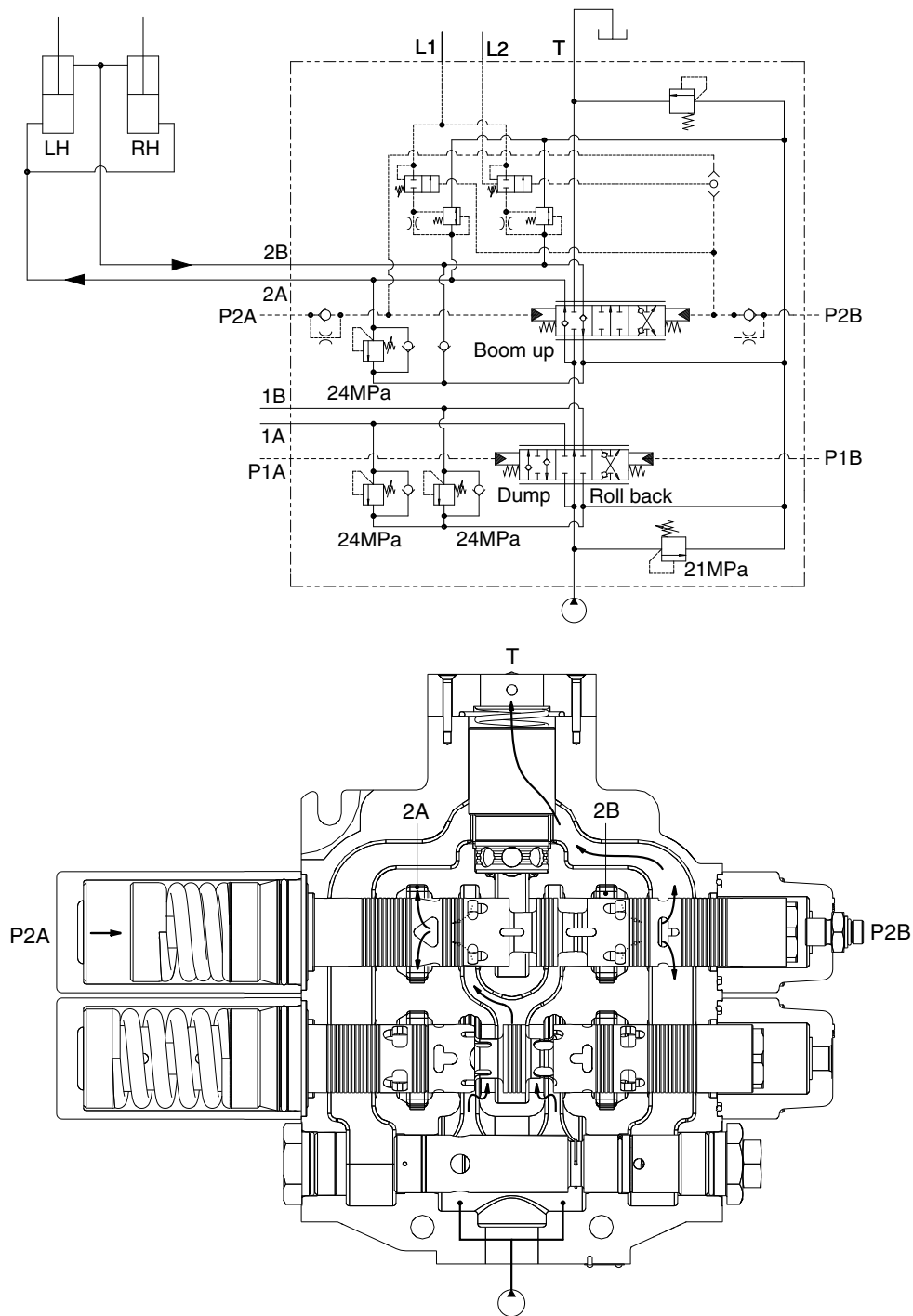

7809SU6WE73

When the pilot pressure from remote control valve is supplied to the pilot port (P3A), the spool moves to the right and the neutral passage is closed.

The oil supplied from the pump flow into boom cylinder port (3A).

The pump pressure reaches proportionally the load of cylinder and fine control finished by shut off of the neutral passage.

The return oil from cylinder port (3B) flows into the tank via the low pressure passage.

### (3) Boom lower position

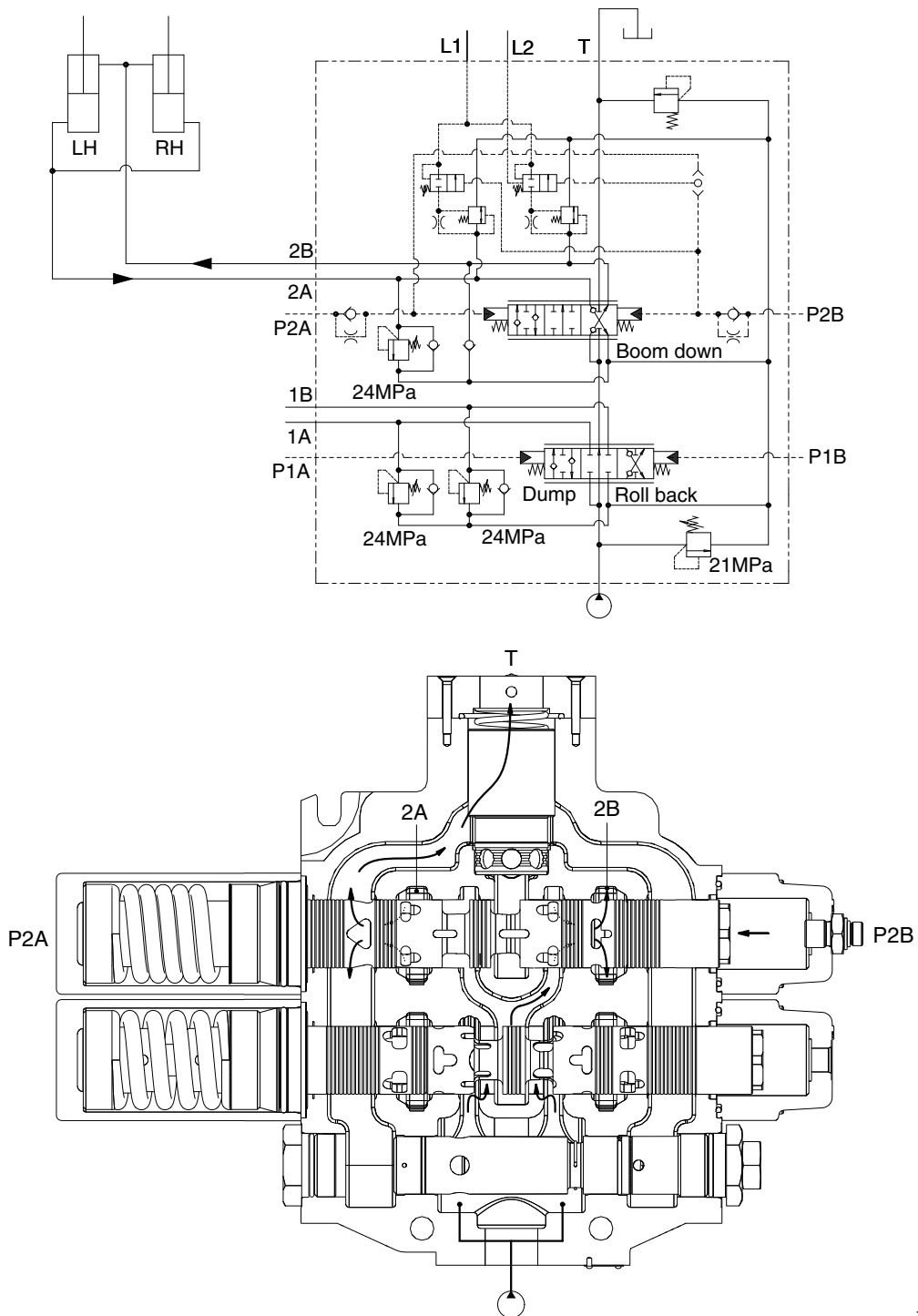

7809SU6WE74

When the pilot pressure from remote control valve is supplied to the pilot port (P3B), the spool moves to the left and the neutral passage is closed.

The oil supplied from the pump flow into boom cylinder port (3B).

The pump pressure reaches proportionally the load of cylinder and fine control finished by shut off of the neutral passage.

The return oil from cylinder port (3A) flows into the tank via the low pressure passage.

※ **Boom float position** : Refer to page 6-6.

### 3) BUCKET SECTION OPERATION

#### (1) Spool in neutral

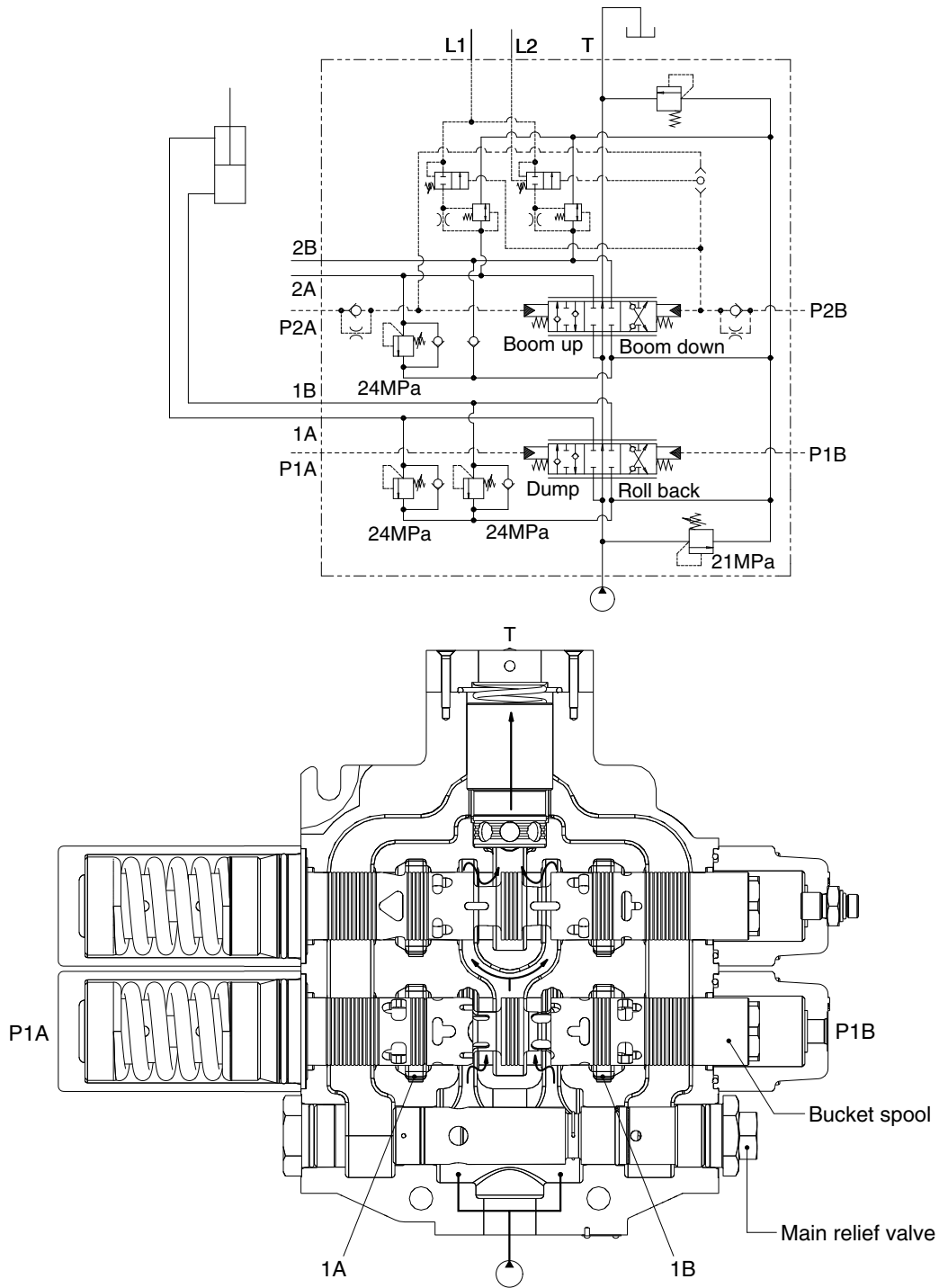

7809S6WE75

If the remote control valve is not operated, the oil supplied from the pump port passage through the neutral passage to the low pressure passage at the outlet section, and then return to the tank port.

(2) Retract (Roll back) position

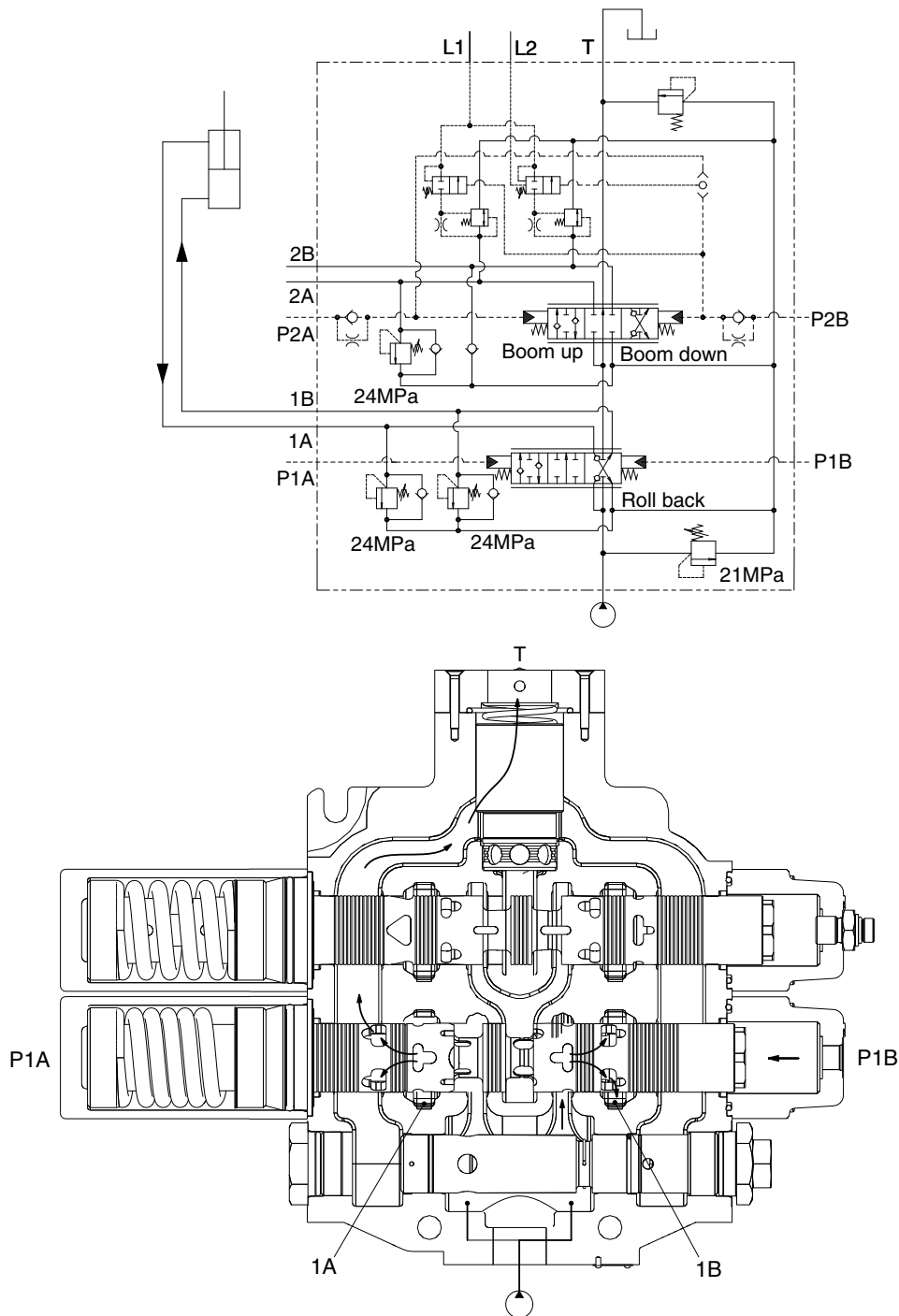

7809SU6WE77

When the pilot pressure from remote control valve is supplied to the pilot port(P2B), the spool moves to the left and the neutral passage is closed.

The oil supplied from the pump flow into bucket cylinder port(2B).

The pump pressure reaches proportionally the load of cylinder and fine control finished by shut off of the neutral passage.

The return oil from cylinder port(2A) flows into the tank via the low pressure passage.

### (3) Dump position

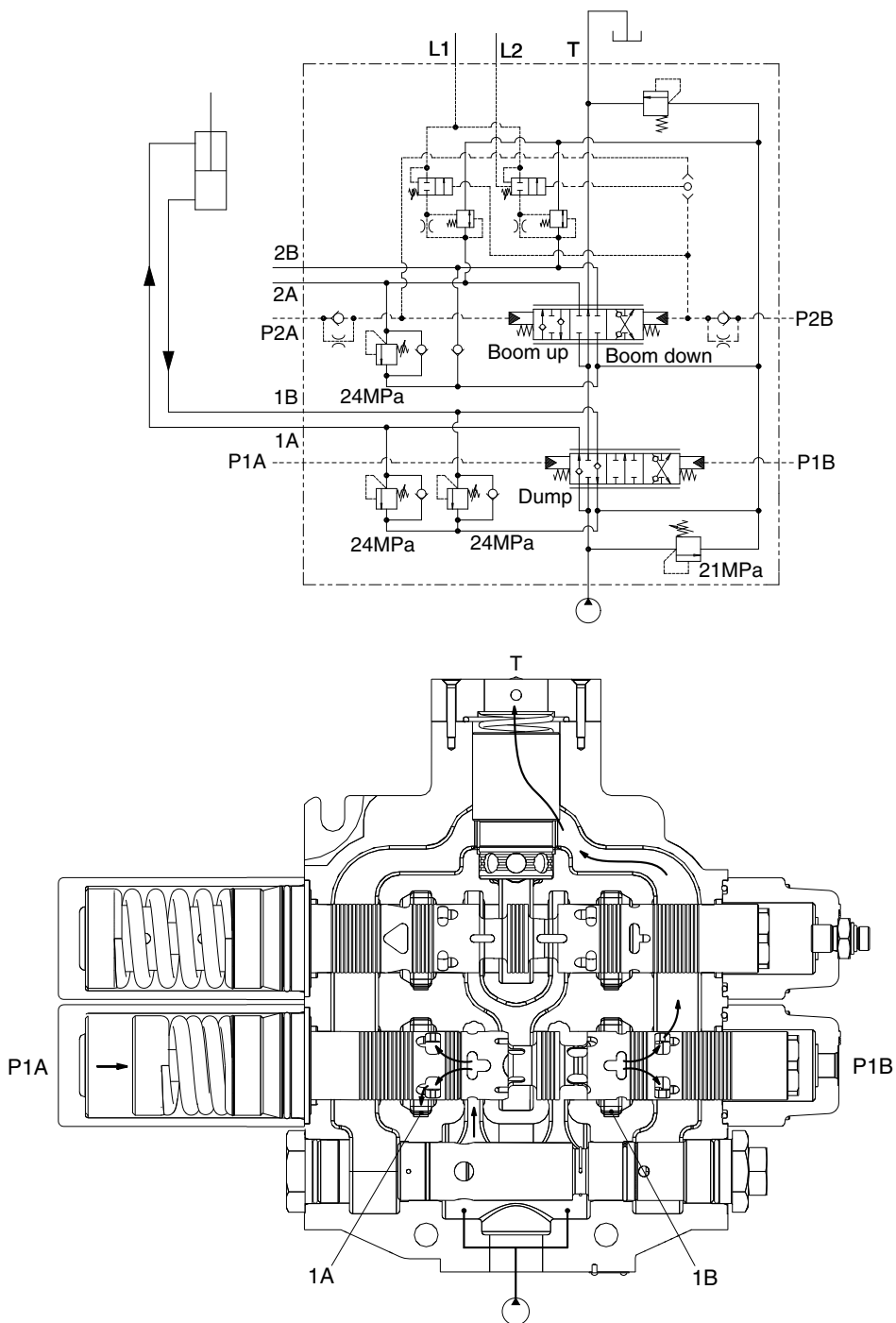

7809SU6WE76

When the pilot pressure from remote control valve is supplied to the pilot port (P2A), the spool moves to the right and the neutral passage is closed.

The oil supplied from the flow into boom cylinder port (2A).

The pump pressure reaches proportionally the load of cylinder and fine control finished by shut off of the neutral passage.

The return oil from cylinder port (2B) flows into the tank via the low pressure passage.

## 6. PILOT OIL SUPPLY UNIT

### 1) STRUCTURE

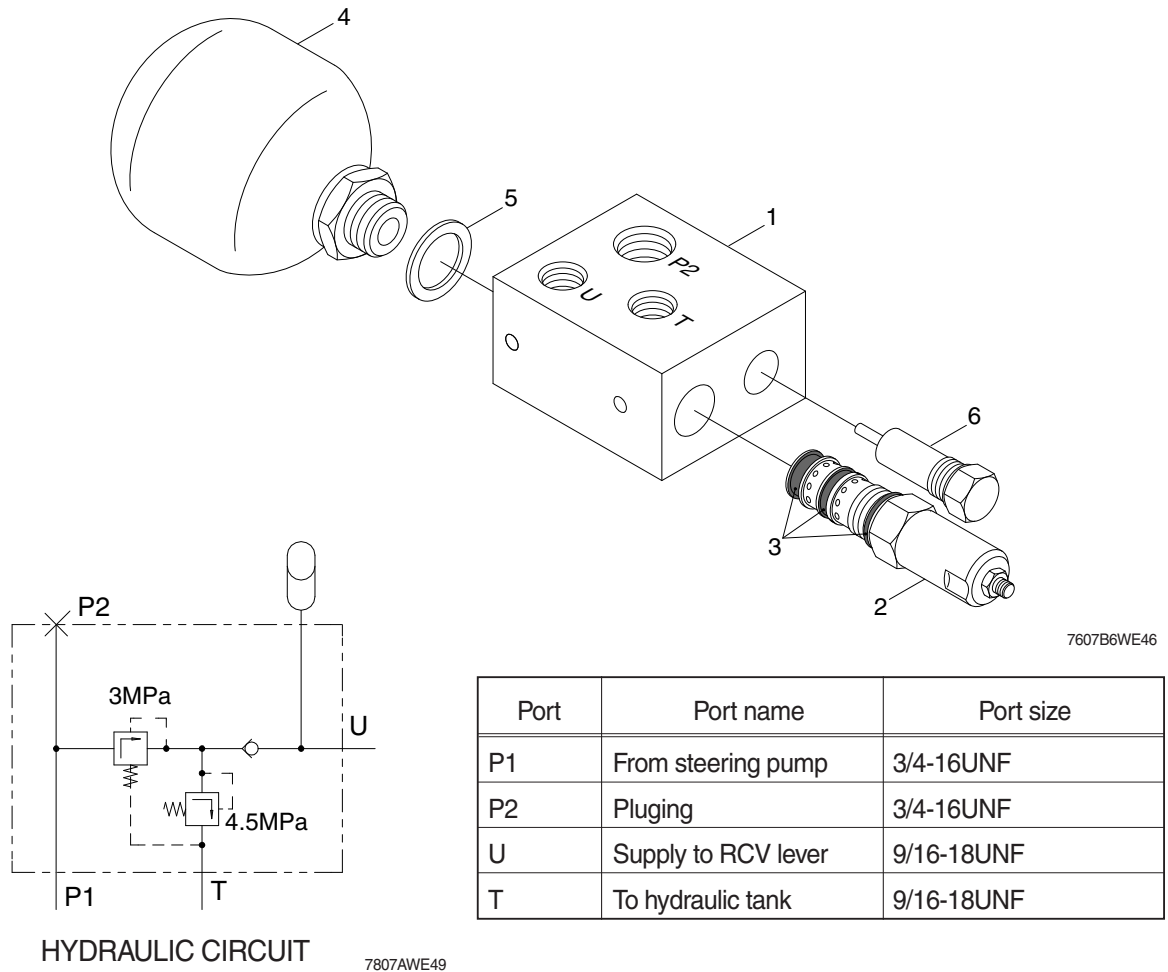

- |   |   |
|---|---|
| <ul style="list-style-type: none"> <li>1 Manifold complete</li> <li>2 Reducing valve</li> <li>3 Seal kit</li> </ul> | <ul style="list-style-type: none"> <li>4 Accumulator</li> <li>5 Gasket</li> <li>6 Relife valve</li> </ul> |
|---|---|

### (2) OPERATION

The pilot supply manifold reduces the pressure from the high pressure circuit to a low pressure circuit in order to supply the remote control valve.

The accumulator satisfies short term peak power demands and is a source of emergency power in case of main circuit pressure failures.

The unit consists of the housing, the accumulator(4), the relief valve (6), the check valve and the reducing valve (2).

The flow path is from the high pressure circuit through port P2 to the pressure reducing valve (2). The pressure is reduced in the reducing valve (2) and oil passes the check valve into the accumulator (4) and to the port U, which is connected with the remote control valve.

The pressure relief valve (6) protects the pilot circuit in case of the reducing valve (2) failures or external increase of pressure.



## 7. BOOM AND BUCKET CYLINDER

The boom cylinders and the bucket cylinders are two unit. They use a bolt on rod guide.

The piston (12) threads on to the rod (2) and is retained by a nut (18) and set screw (19).

The piston seals against the tube (1) with piston seal (15). Two wear rings (16) are located on each side of the piston seal.

The gland (3, the rod guide) seals against the tube with an O-ring (10). The cylinder thread seals against the rod with a lip type buffer ring (7) and a rod seal (5). A dust wiper (8) cleans the rod when it is retracted.

### 1) BOOM CYLINDER

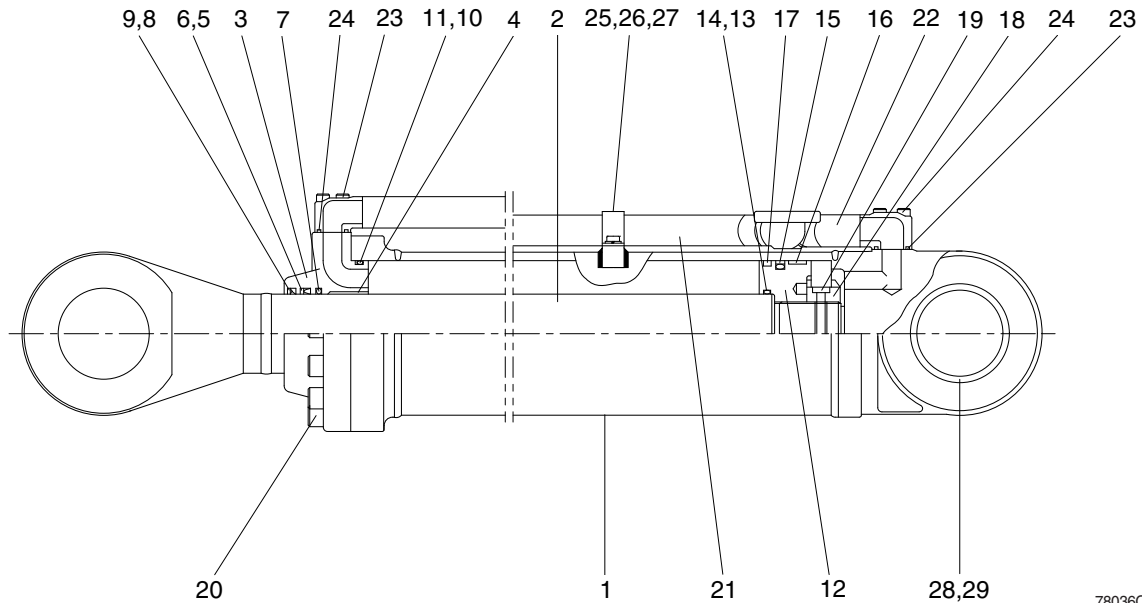

78036CY02

1	Tube assy	11	Back up ring	21	Pipe assy
2	Rod assy	12	Piston	22	Pipe assy
3	Gland	13	O-ring	23	O-ring
4	Bushing	14	Back up ring	24	Bolt
5	Rod seal	15	Piston seal	25	Clamp
6	Back up ring	16	Wear ring	26	Bolt
7	Buffer ring	17	Dust ring	27	Spring washer
8	Dust wiper	18	Lock nut	28	Bushing
9	Snap ring	19	Set screw	29	Dust seal
10	O-ring	20	Bolt		

## 2) BUCKET CYLINDER

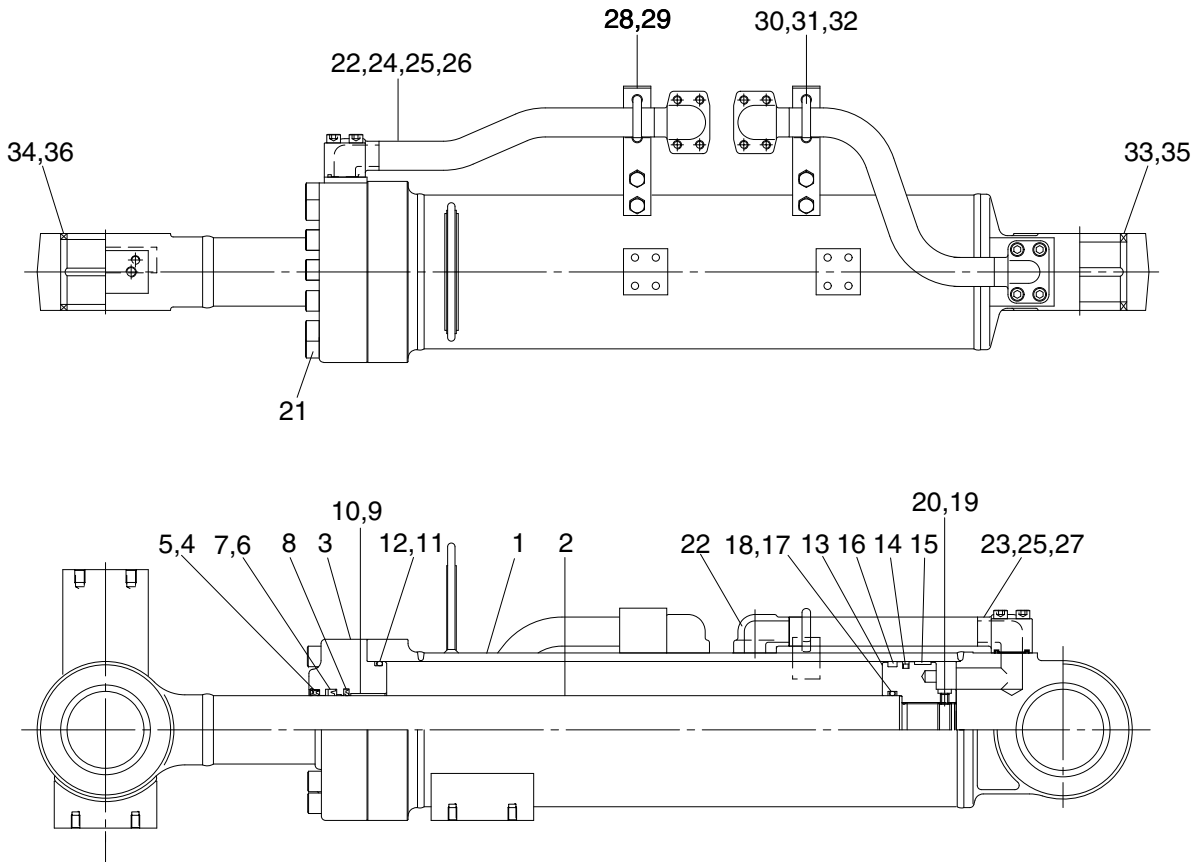

7809SU6WE18

1	Tube assy	13	Piston	25	O-ring
2	Rod assy	14	Piston seal	26	Bolt
3	Gland	15	Wear ring	27	Bolt
4	Dust wiper	16	Dust ring	28	Plate
5	Retaining ring	17	O-ring	29	Bolt
6	Rod seal	18	Back up ring	30	U-bolt
7	Back up ring	19	Steel ball	31	Nut
8	Buffer ring	20	Set screw	32	Spring washer
9	Dry bearing	21	Bolt	33	Pin bush
10	Retaining ring	22	Block	34	Pin bush
11	O-ring	23	Pipe assy	35	Dust seal
12	Back up ring	24	Pipe assy	36	Dust seal

## 8. HYDRAULIC OIL TANK

### 1) STRUCTURE

- The oil from the hydraulic tank is sent from the pump through main control valve to the cylinders. In the return circuit, the oil from various parts merges.
- A part of oil is cooled in the oil cooler, passes through the hydraulic filter and returns to the hydraulic tank (1).
- If the hydraulic return oil filter becomes clogged, return filter bypass valve (7) acts to allow the oil to return directly to the hydraulic tank (1). This prevents damage to the hydraulic filter (6). The bypass valve (7) is also actuated when negative pressure is generated in the circuit.

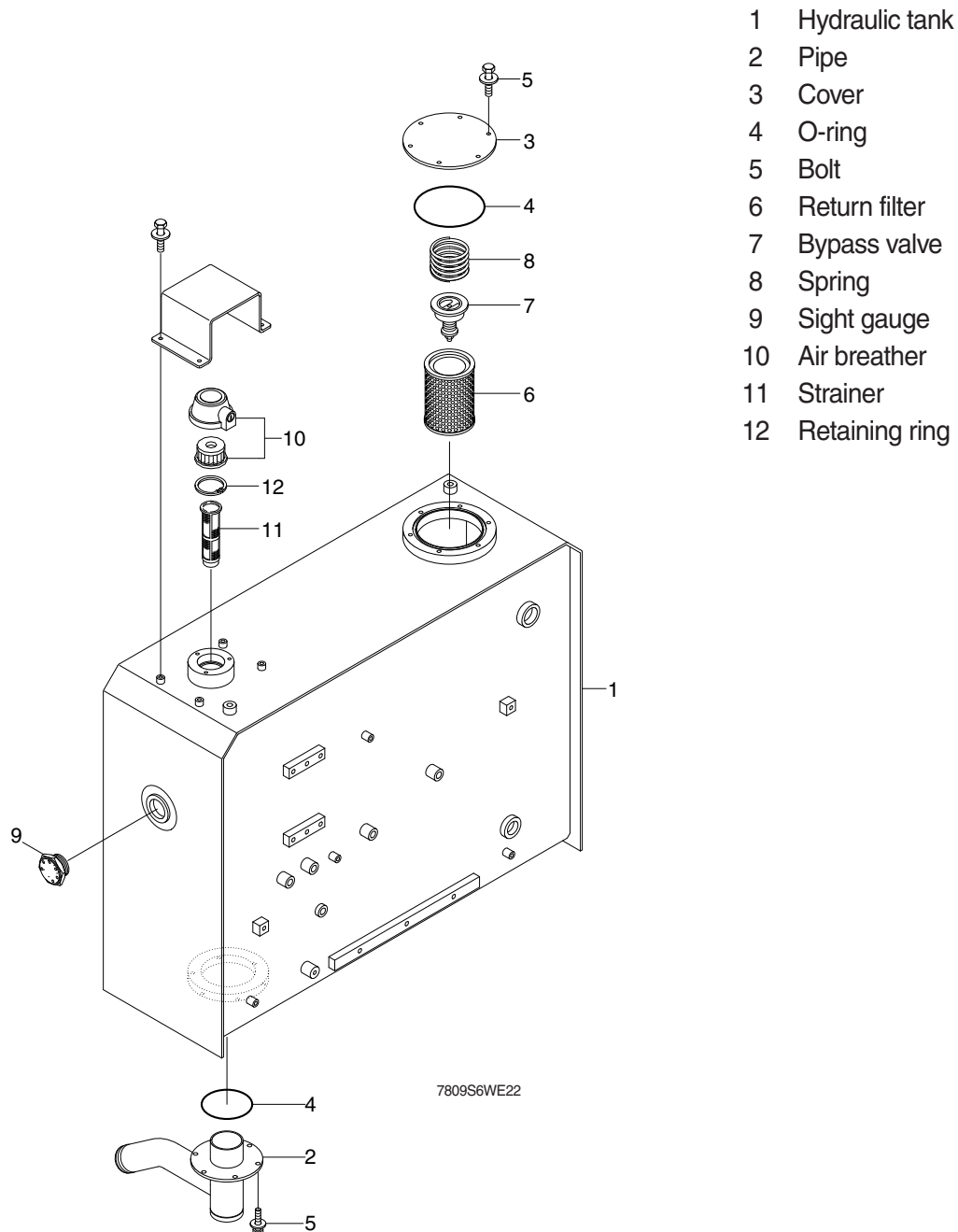

## 2) RETURN OIL FILTER BYPASS VALVE

### (1) When the filter is clogged

Bypass valve (1) is opened and the oil returns directly to the tank without passing through the filter.

- Bypass valve set pressure : 1.36 kg/cm<sup>2</sup>  
(19.3 psi)

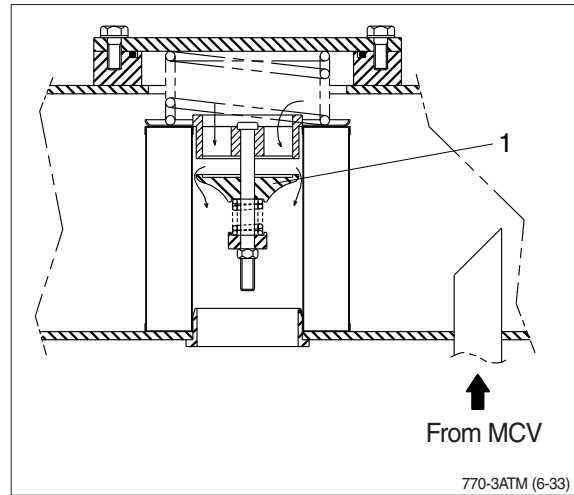

### 3) AIR BREATHER

The air breather is equipped with the capacity to perform three functions simultaneously-as an air filter, breathing valve, and as a lubrication opening.

#### (1) Preventing negative pressure inside the tank

The tank is a pressurized sealed type, so negative pressure is formed inside the hydraulic tank when the oil level drops during operations. When this happens, the difference in pressure between the tank and the outside atmospheric pressure opens the poppet in the breather, and air from the outside is let into the tank or prevent negative pressure.

#### (2) Preventing excessive pressure inside the tank

When the hydraulic cylinder is being used, the oil level in the hydraulic system increases and as temperature rises. If the hydraulic pressure rises above the set pressure, breather is actuated to release the hydraulic pressure inside the tank.

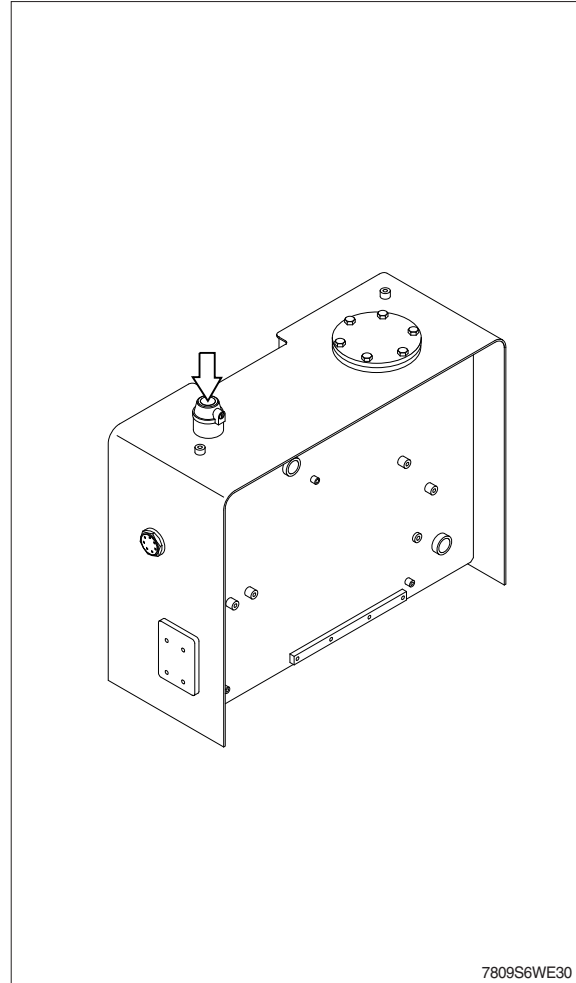

## 9. ACCUMULATOR

The accumulator is installed at the safety valve. When the boom is left the raised position, and the control levers are operated with the engine stopped the pressure of the compressed nitrogen gas inside the accumulator sends pilot pressure to the control valve to actuate it and allow the boom and bucket to come down under their own weight.

Type of gas	Nitrogen gas (N <sub>2</sub> )
Volume of gas	0.75 l (0.2 U.S.gal)
Charging pressure of gas	16 kg/cm <sup>2</sup> (228 psi)
Max actuating pressure	128 kg/m <sup>2</sup> (1820 psi)

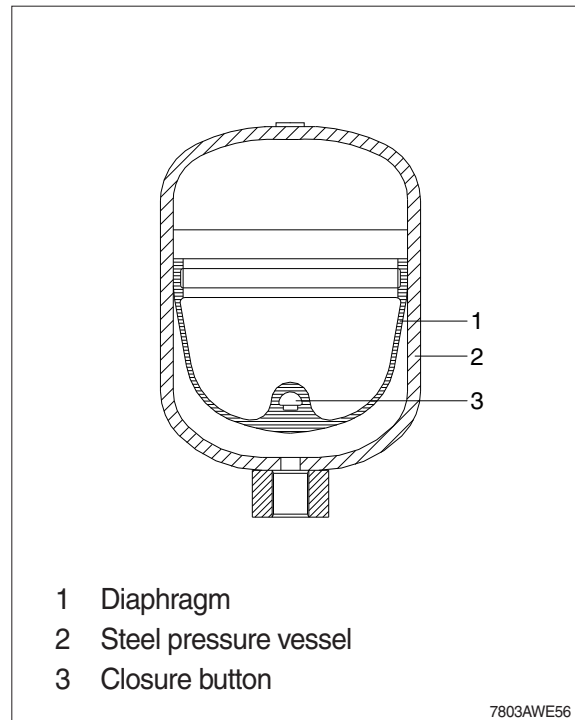

## 10. RIDE CONTROL SYSTEM

### 1) ACCUMULATORS

#### (1) Pre-charging

Use an inert gas such as nitrogen for pre-charging accumulator.

- ※ Do not use oxygen or shop air.
- ※ Nitrogen source and all components must be rated for a pressure at least as high as the nitrogen source.

#### Accumulator having gas valve as per figure 1.

- ① Remove gas valve guard and gas valve cap.
- ② Back gas chuck "T" handle (A) all the way out (counter clockwise) before attaching charging & gauging kit to accumulator gas valve.
- ③ Close bleed valve (B).
- ④ Making sure not to loop or twist the hose, attach swivel nut (C) to gas valve and tighten 11.5~17 kgf·cm (10~15 lbf·ft).
- ⑤ Turn gas chuck "T" handle (A) until the gauge starts showing the pressure in the accumulator. Do not turn the "T" handle all the way down, as it will damage the valve core.
- ⑥ Crack open nitrogen bottle valve (D) and **slowly** fill accumulator. Shut off when gauge indicates desired pre-charge.
- ⑦ Let the pre-charge set for 10 to 15 minutes. This will allow the gas temperature to stabilize. If the desired pre-charge is exceeded, close nitrogen bottle valve (D), then slowly open bleed valve (B). Do not reduce pre-charge by depressing valve core with a foreign object. High pressure may rupture rubber valve seat.
- ⑧ When finished pre-charging accumulator, turn "T" handle (A) all the way out on gas chuck, then open bleed valve (B).
- ⑨ Hold gas valve to keep from turning, loosen swivel nut (C), remove assembly. Check for pre-charge leak using a common leak reactant.
- ⑩ Replace gas valve cap 11.5~17 kgf·cm (10~15 lbf·ft) and valve guard. (Gas valve cap serves as a secondary seal.)

#### (2) Pre-charge checking procedure

Using appropriate valve in the hydraulic system, discharge all oil from accumulator and allow piston to bottom against hydraulic end cap.

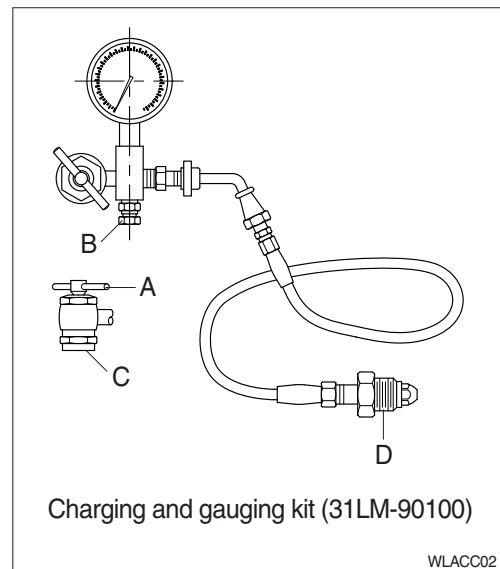
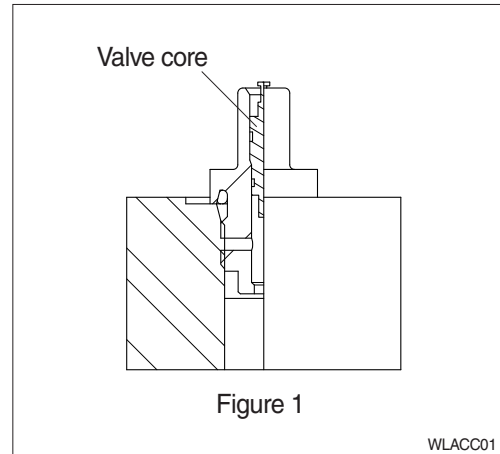

### (3) Structure

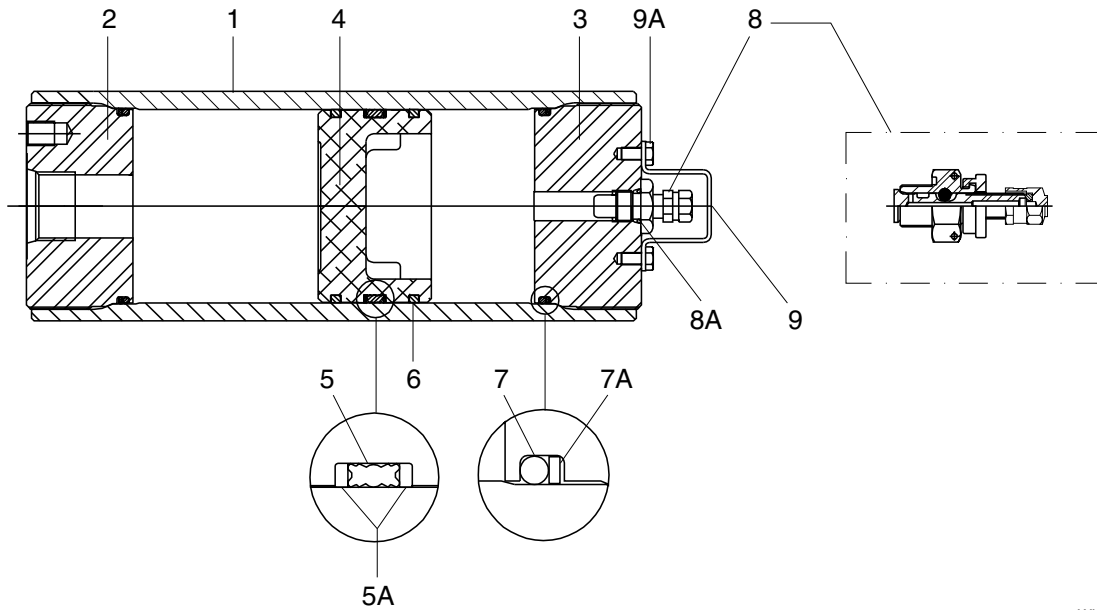

WLACC03

- 1 Body
- 2 Hydraulic cap
- 3 Gas cap
- 4 Piston
- 5 V-O-ring
- 5A V-O-ring back-up washers
- 6 Piston ring (piston)
- 7 O-ring
- 7A O-ring back-up washer
- 8 Gas valve
- 8A Gas valve O-ring
- 9 Gas valve guard
- 9A Screw

#### Specification for accumulator

Item	31LB-94000
Length	635.51 mm
Norminal volume	4.0 l
Precharge pressure	20±0.9 bar
Operating medium	Oil
Weight	21.31 kg
Priming gas	Nitrogen

**▲ Before carrying out any maintenance work the accumulators must be unloaded (zero pressure). Refer to the page 6-56.**