

SECTION 7 ELECTRICAL SYSTEM

Group 1 Component Location	7-1
Group 2 Electrical Circuit	7-3
Group 3 Monitoring System	7-21
Group 4 Electrical Component Specification	7-50
Group 5 Connectors	7-57
Group 6 Troubleshooting	7-77

SECTION 7 ELECTRICAL SYSTEM

GROUP 1 COMPONENT LOCATION

1. LOCATION 1

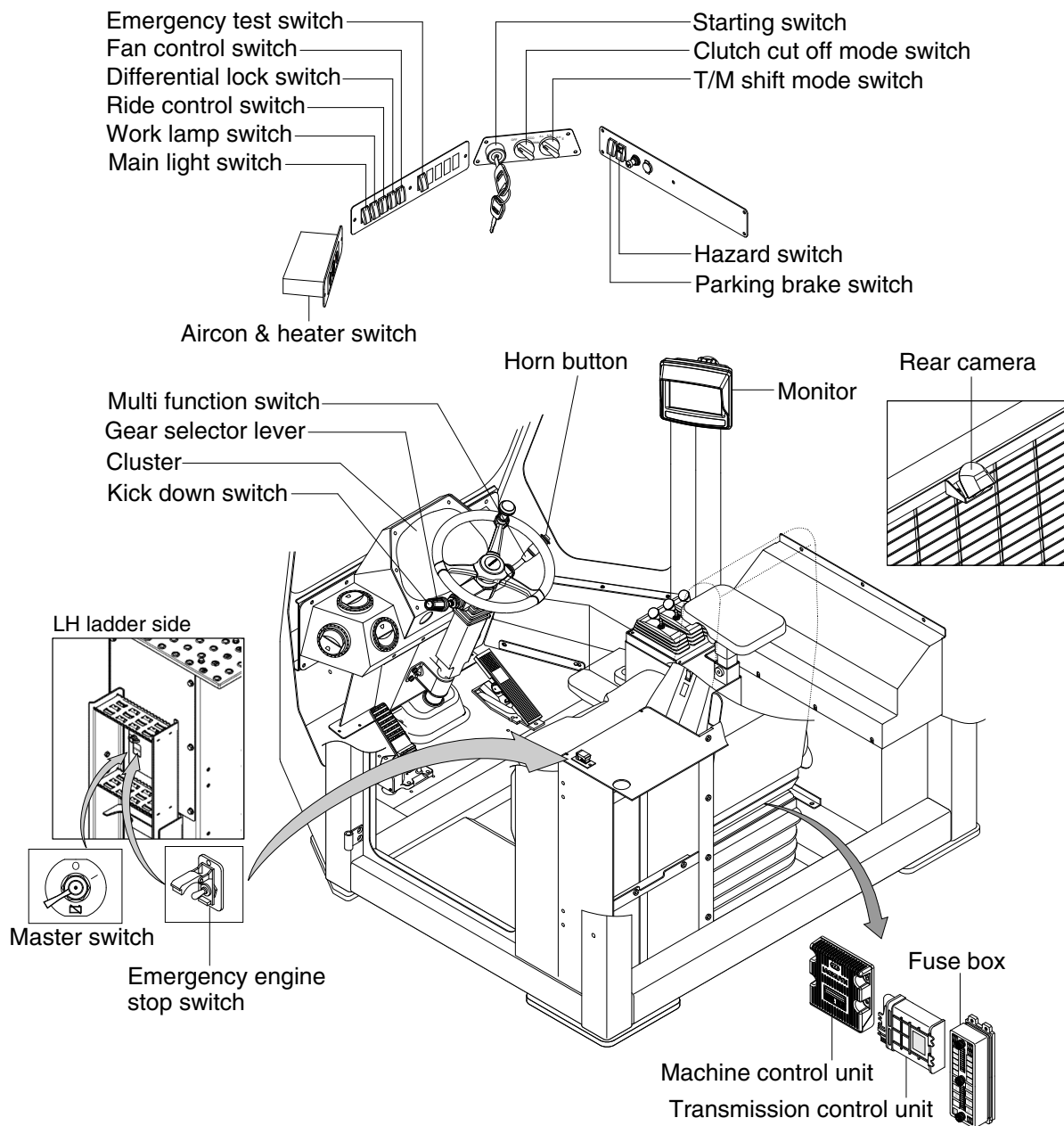

7809SU7EL02

2. LOCATION 2

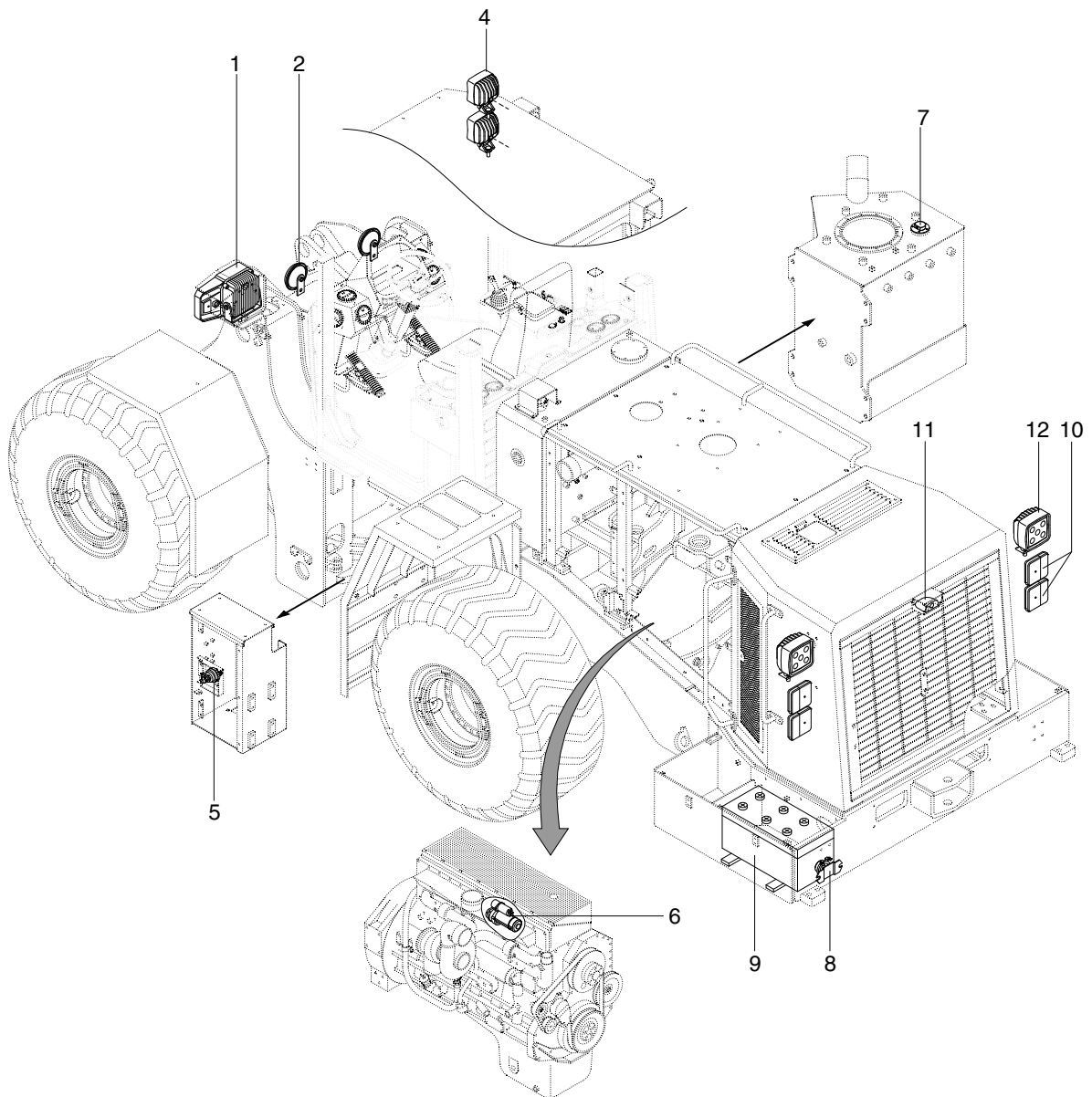

7809SU7EL02-1

- | | | | | | |
|---|---------------|---|---------------|----|---------------------|
| 1 | Head lamp | 6 | Start relay | 10 | Rear combi lamp-LED |
| 2 | Horn | 7 | Fuel sender | 11 | Camera |
| 4 | Work lamp | 8 | Battery relay | 12 | Work lamp |
| 5 | Master switch | 9 | Battery | | |