

## GROUP 6 TROUBLESHOOTING

### 1. WHEN STARTING SWITCH IS TURNED ON, CLUSTER LAMP DOES NOT LIGHT UP

- Before carrying out below procedure, check all the related connectors are properly inserted and the fuse No.25 is not blown out and ON/OFF of bulb.
- After checking, connect the disconnected connectors again immediately unless otherwise specified.

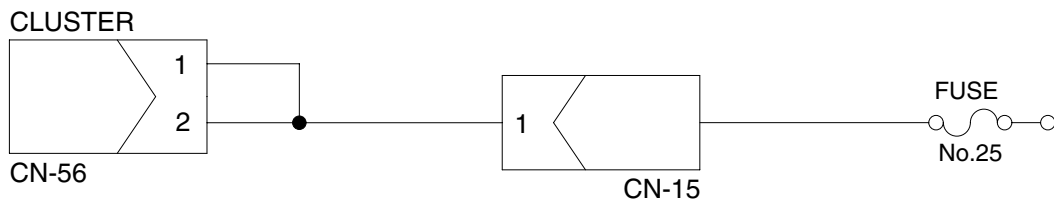
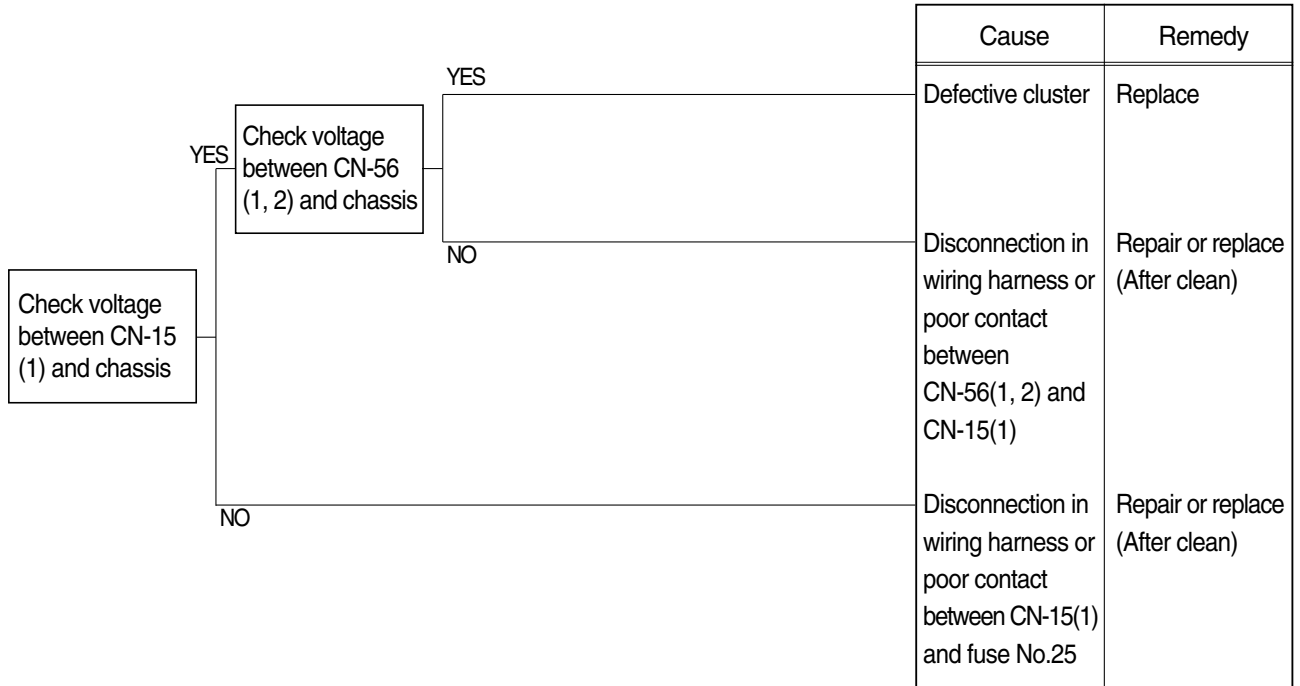

#### Check voltage

YES	20 ~ 30V
NO	0V

7807AEL15

## 2. WHEN BATTERY LAMP LIGHTS UP (Engine is started)

- Before carrying out below procedure, check all the related connectors are properly inserted.
- After checking, connect the disconnected connectors again immediately unless otherwise specified.

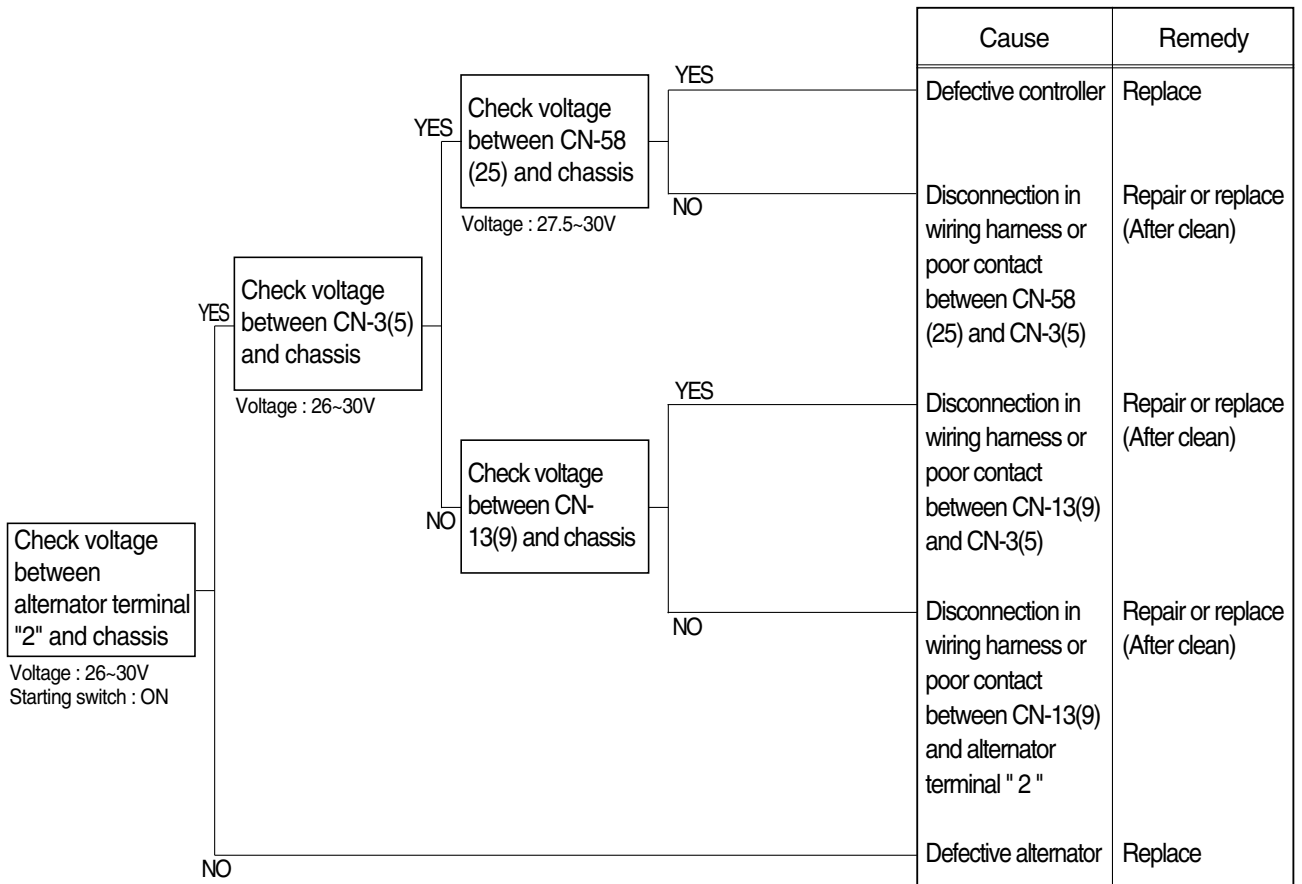

### CONTROLLER(MCU)

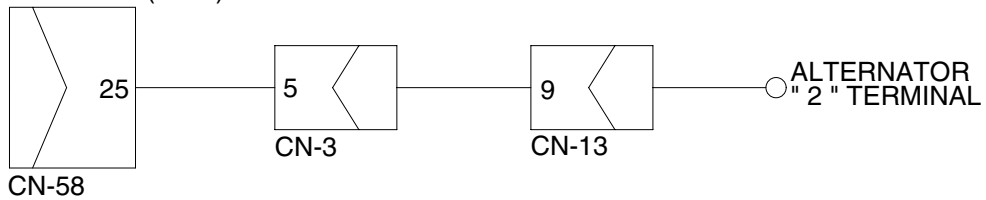

### Check valtage

YES	20 ~ 30V
NO	0V

7807AEL16

### 3. WHEN PARKING SOLENOID DOES NOT WORK

- Before carrying out below procedure, check all the related connectors are properly inserted and the fuse No.8 is not blown out.
- After checking, connect the disconnected connectors again immediately unless otherwise specified.

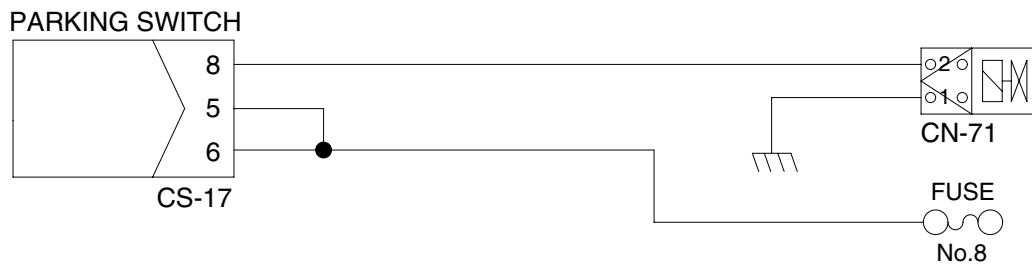
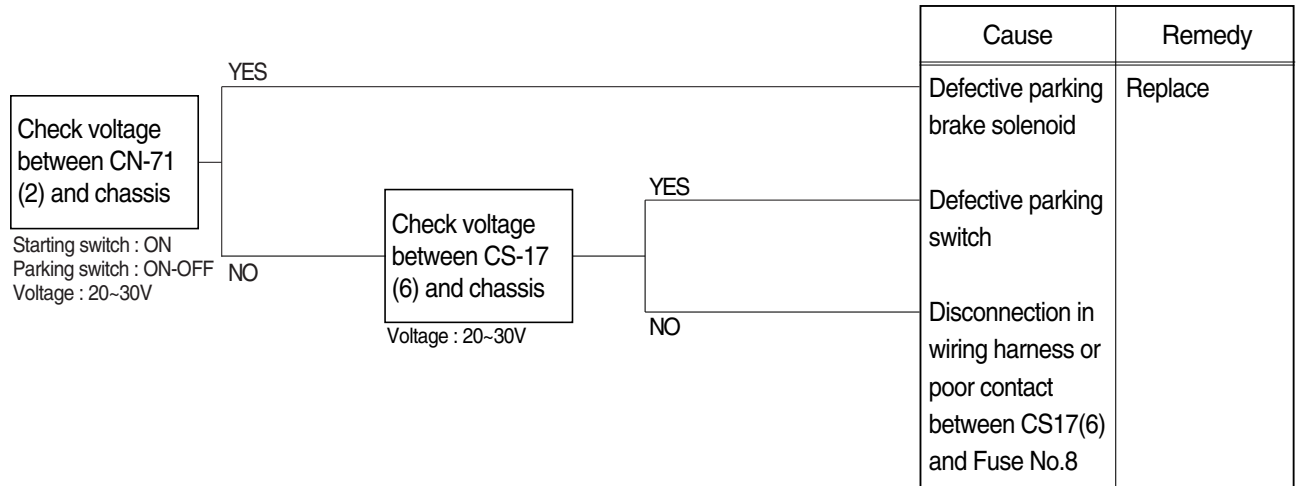

7707EL24

#### 4. TRANSMISSION IS NOT RETURNED TO NEUTRAL WHEN PARKING BRAKE IS APPLIED

- Before carrying out below procedure, check all the related connectors are properly inserted and the fuse No.17(T/M control unit) and No.8 are not blown out.
- After checking, connect the disconnected connectors again immediately unless otherwise specified.

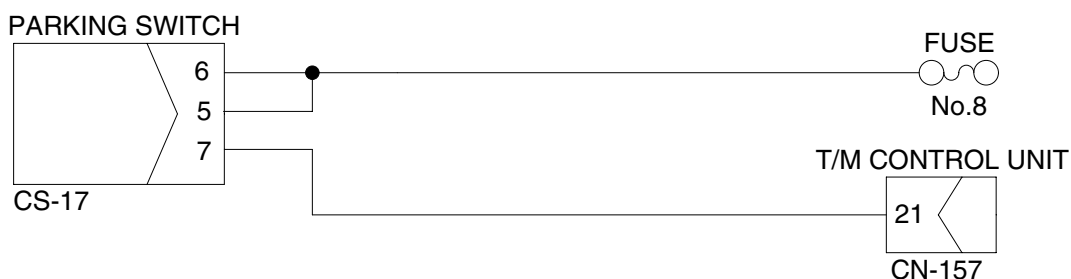
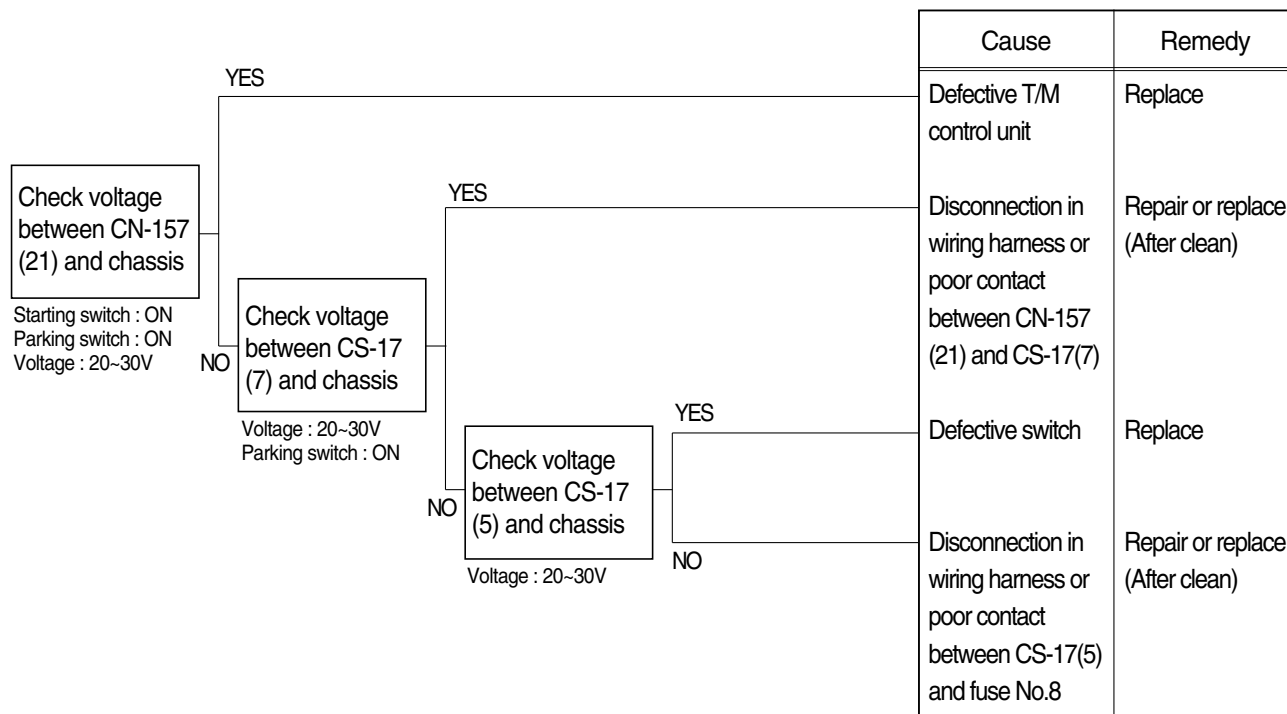

#### Check resistance

YES	MAX 1 Ω
NO	MIN 1M Ω

7807AEL17

## 5. MACHINE DOES NOT TRAVEL

- Before carrying out below procedure, check all the related connectors are properly inserted and the fuse No.17(Transmission controller) is not blown out.
- After checking, connect the disconnected connectors again immediately unless otherwise specified.
- Wiring diagram : **See page 7-16.**

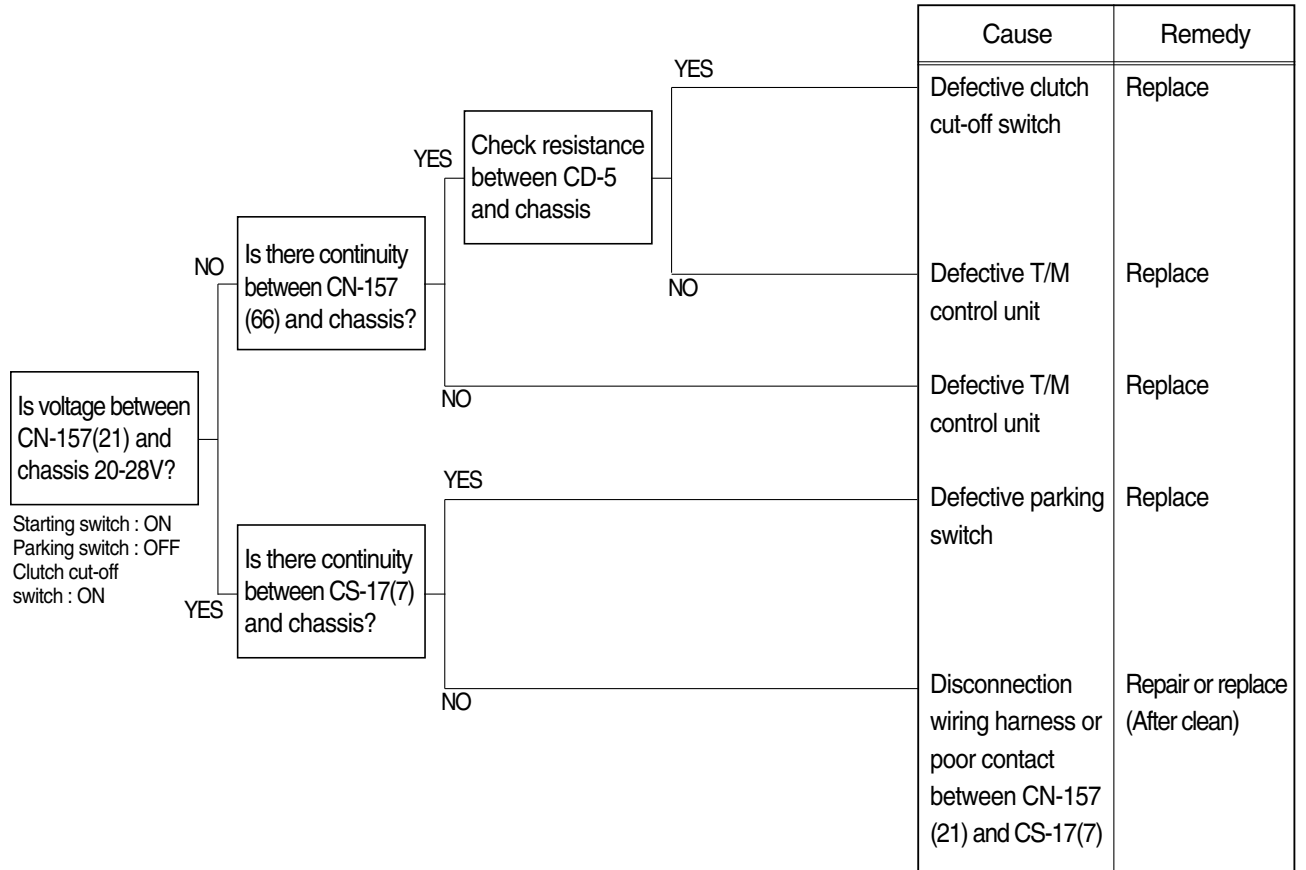

### Check resistance

YES	MAX 1 Ω
NO	MIN 1M Ω

## 6. WHEN STARTING SWITCH IS TURNED ON, WIPER MOTOR DOES NOT OPERATE

- Before carrying out below procedure, check all the related connectors are properly inserted and the fuse No.9 is not blown out.
- After checking, connect the disconnected connectors again immediately unless otherwise specified.

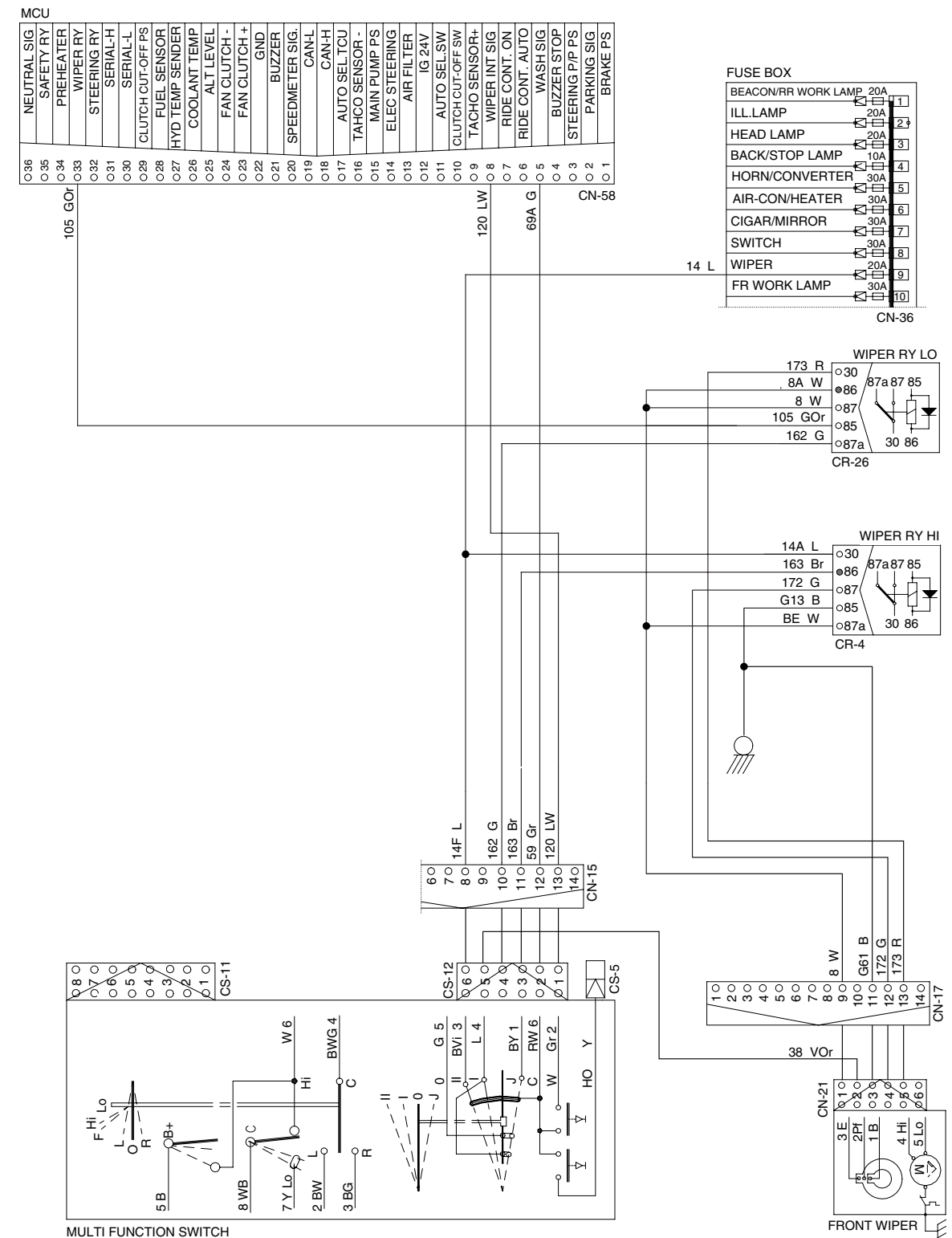
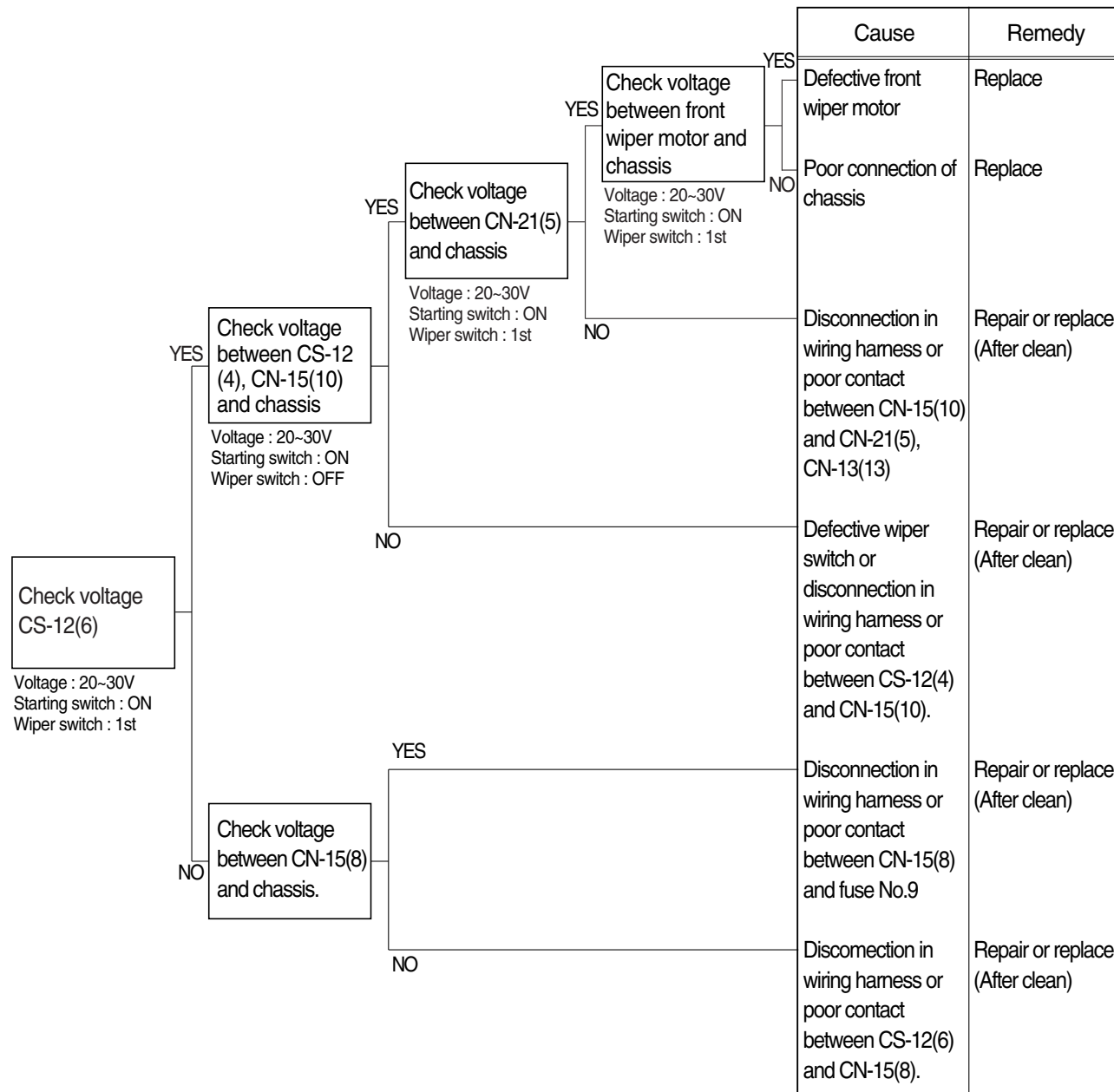



## 8. WHEN STARTING SWITCH IS TURNED ON, WORK LAMP DOES NOT LIGHTS UP

- Before carrying out below procedure, check all the related connectors are properly inserted, and the fuse No.1, 10 is not blown out.
- After checking, connect the disconnected connectors again immediately unless otherwise specified.

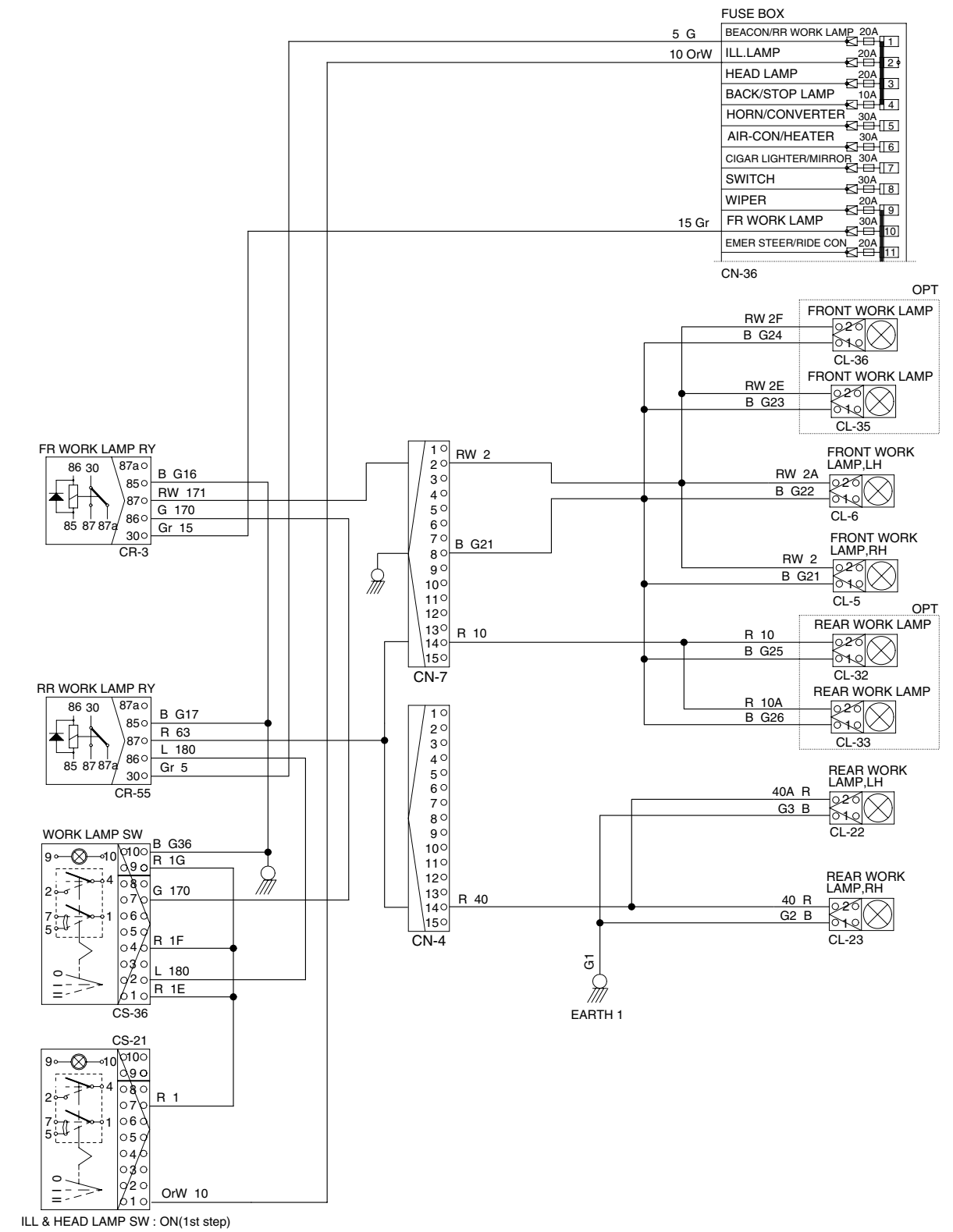
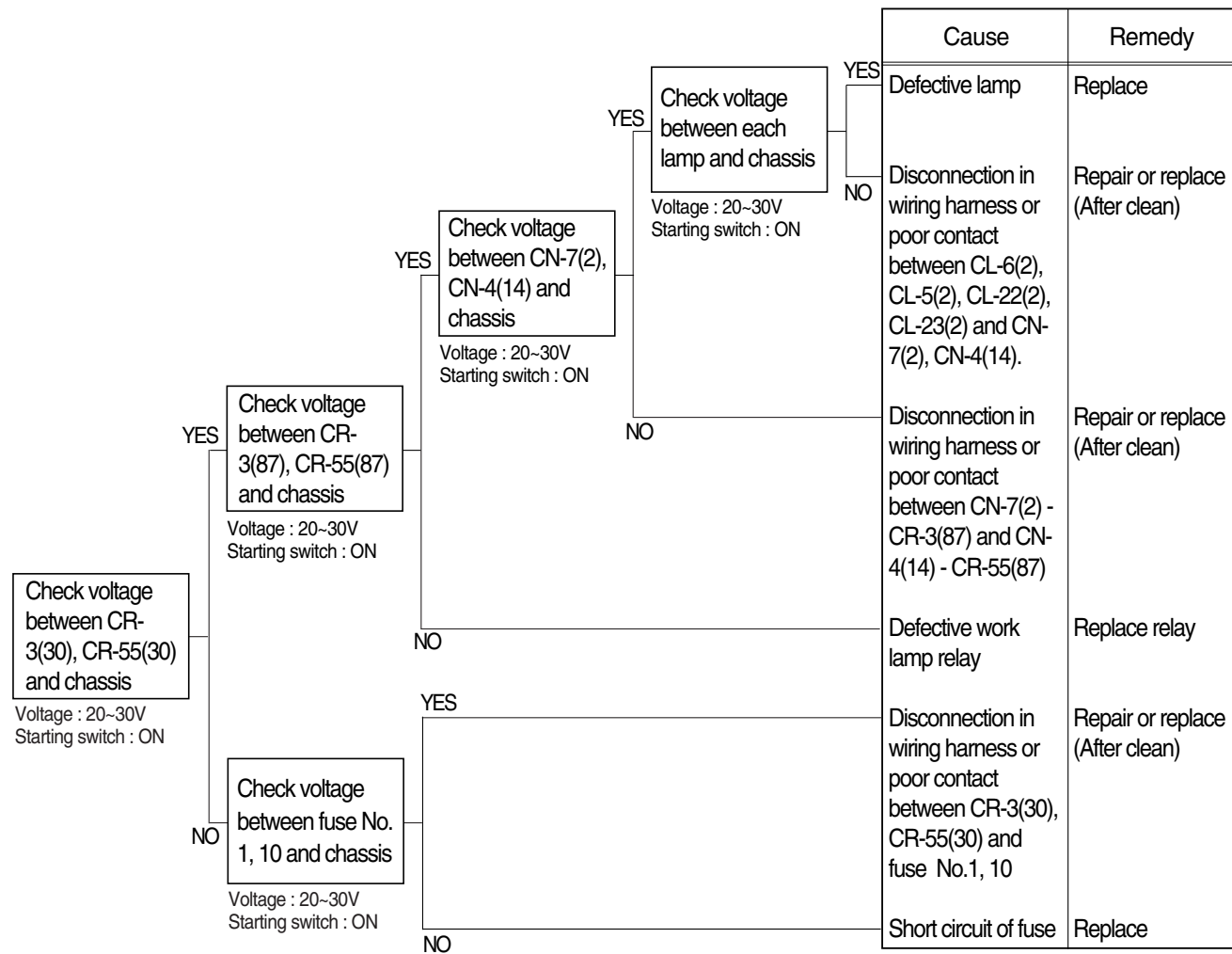



## 9. WHEN ENGINE DOES NOT START

- Check supply of the power at engine stop solenoid while starting switch is ON.
- Before carrying out below procedure, check all the related connectors are properly inserted.
- After checking, connect the disconnected connectors again immediately unless other wise specified.
- Check forward reverse switch at neutral position.

