

GROUP 4 DISASSEMBLY AND ASSEMBLY

1. MAIN PUMP

1) STRUCTURE(1/2)

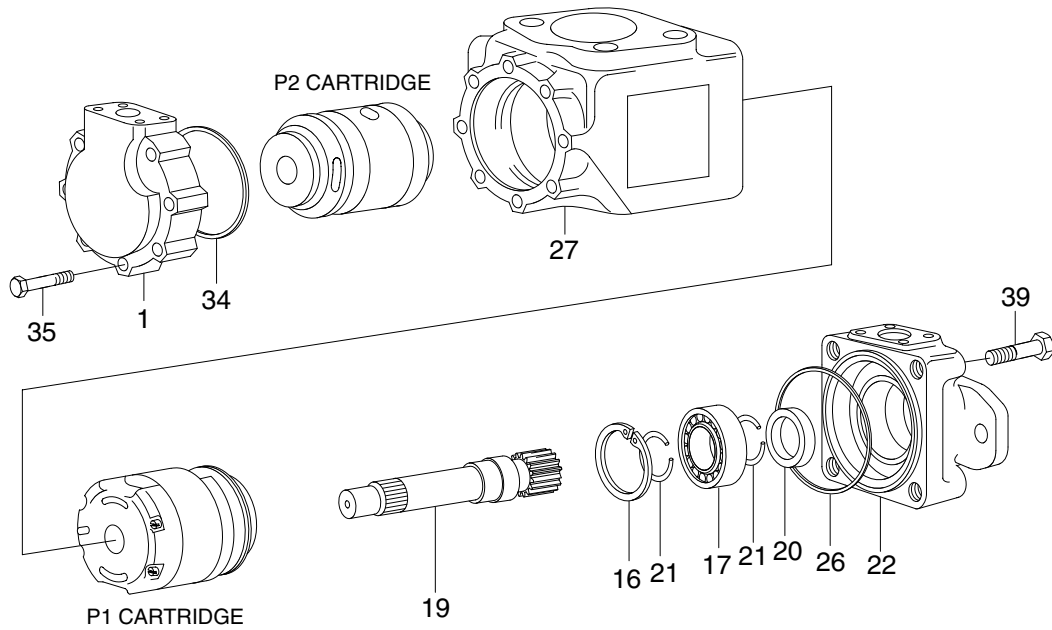

7807WE28

- | | | | |
|----|--------------------|----|----------------|
| 1 | End cap | 22 | Mounting cap |
| 2 | Bushing | 26 | Section seal |
| 16 | Internal snap ring | 27 | Center housing |
| 17 | Ball bearing | 34 | Section seal |
| 19 | Splined shaft | 35 | Cap screw |
| 20 | Shaft seal | 39 | Cap screw |
| 21 | Internal snap ring | | |

STRUCTURE(2/2)

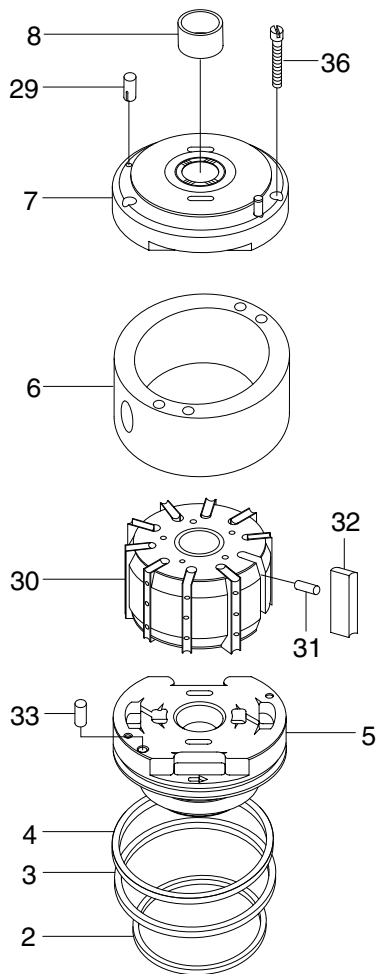

P2 CARTRIDGE

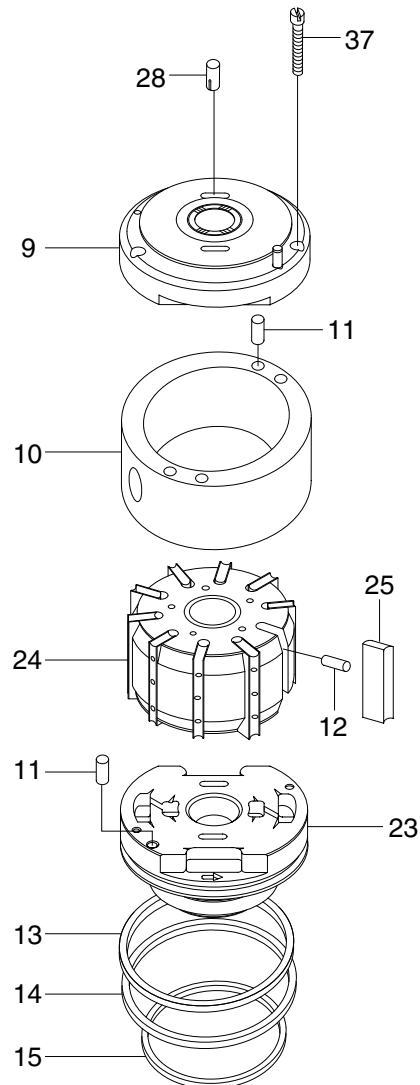

P1 CARTRIDGE

7807AWE29

- | | | | | | |
|----|---------------------|----|---------------------|----|------------------|
| 2 | Section seal | 11 | Dowel pin | 29 | Lock pin |
| 3 | Section seal | 12 | Vane holdout pin | 30 | Rotor assembly |
| 4 | Back up ring | 13 | Back up ring | 31 | Vane holdout pin |
| 5 | Pressure port plate | 14 | Section seal | 32 | Vane |
| 6 | Camring | 15 | Section seal | 33 | Dowel pin |
| 7 | Rear port plate | 23 | Pressure port plate | 36 | Screw |
| 8 | Bush bearing | 24 | Rotor assembly | 37 | Screw |
| 9 | Rear port plate | 25 | Vane | | |
| 10 | Camring | 28 | Lock pin | | |

2) GENERAL INSTRUCTION

(1) Preliminary

- ※ Any servicing work done on main pump is to be done in a clean environment to prevent potential contamination by foreign particles.
- ※ Appropriate tools and equipment are required in order to insure proper disassembly and reassembly in suitable conditions. In case of repetitive service, a specific working bench is recommended.
- ※ To prevent oil leakage and body tilting during assembly, housing bolts are to be tightened as per the following pattern !

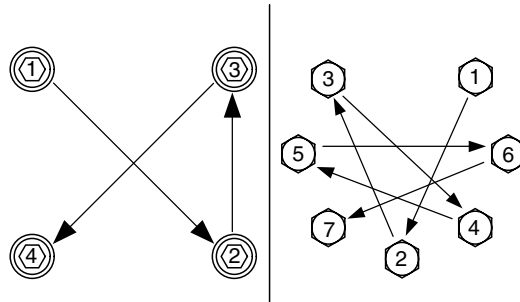

7803AWE05

(2) Parts

- ※ Parts must be kept clean at all time. If cleaning is needed, solvent is to be used. It is needed to check and oil the inner parts before assembly.
- ※ In case of replacement of parts with multiple numbers, such as vanes and holdout pins, all the parts are to be changed.

① Vanes

The faces and edges should be free of scratch from contamination. Vanes should move smoothly in the rotor slots, without excessive clearance. Edges may be stoned with a fine India stone to remove burrs.

② Vane holdout pins :

Holdout pins should have no matting marks.

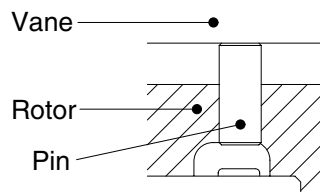

7803AWE50

③ Rotor :

Side surfaces and vane slots should be free of scratches. Side feeds, vane slots and holdout pin orifices should be free of any contamination. Serration(driving splines) should not be deformed by the shaft.

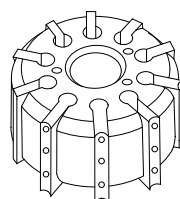

7803AWE51

④ **Camring :**

No scratches or vane shock marks(waves) should be seen. Visual axial waves on new camring are from grinding process and therefore normal.

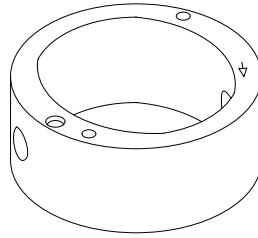

7803ASE06

⑤ **Port plates :**

Faces should not be scratched. No cavitation/aeration/fretting corrosion marks should be seen. When there, the bronze bushing should be clean, with no abnormal wear sign.

- ※ Bi-directional cartridges use same port plates for CW and CCW rotation. **Unit-directional** cartridges require different port plates.

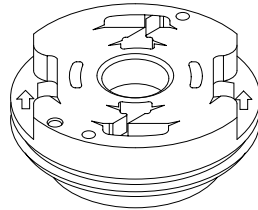

7803ASE08

⑥ **Seals :**

- All oil seals must be cleaned, with no wear or cutting mark. When servicing a pump from field operation, it is highly recommended to change all seals. All seals are to be greased lightly before assembly.
- Use seal driver tool to install shaft seal, and protective cone to install shaft assembly.
- Backup rings(1) on pressure plates are to be replaced, anytime a cartridge is taken out of a pump. Backup rings are to be installed as follow, behind the square seal :

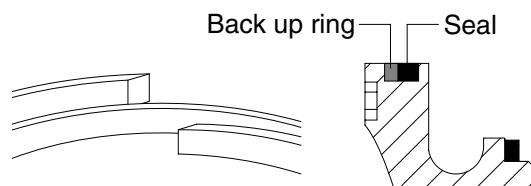

7803ASE07

⑦ **Shaft :**

- Key-way should be clean and not worn on the sides by excessive torque. No fretting corrosion due to poor coupling should be visible. On spline shaft, splines should not be deformed.
- No axial scratch should be on the sealing area(1). The shaft seal lip contact line may be visible, but should not be a groove. Bronze-bushing contact area(2) should be clean and cylindrical, without scratch marks.

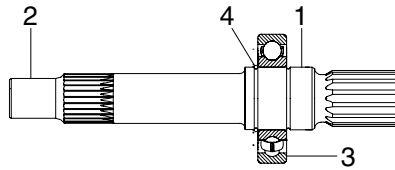

7803ASE10

- Ball bearing(3) should turn freely and snap ring(4) should be in place. Some shaft assemblies have 2 snap rings, before and after the ball bearing.

※ **Never insert a snap ring from shaft seal side, to avoid scratching the sealing surface.**

- ※ Use protective cone to install shaft assembly. If not available, make sure not to damaged the shaft seal lips.

(3) Pre start check and priming.

① Before operating the pump again, the following points are to be checked :

- Pump rotation is as per electric motor or engine.
- All fittings are properly connected and tight. No oil-leak and/or air intake being allowed.
- If any, valve on suction line is to be fully opened.

② When electric motor or engine is started up, the pump should prime immediately. However, depending on installation and amount of air in the discharge lines, priming may take a few seconds.

③ In case priming does not occur within 15 seconds, equipment should be switched off at once.

- Then :
- Manually fill the pump housing with fluid.
- Bleed off air that may be trapped in the pump.
- Check air bleed-off valves.
- Start rotation in a jogging manner until a prime is picked up.

3) DISASSEMBLY

- (1) Install the pump on the table.
 - ※ Two bolts will help to unscrew the 4 pump bolts.
- (2) Unscrew the bolts.

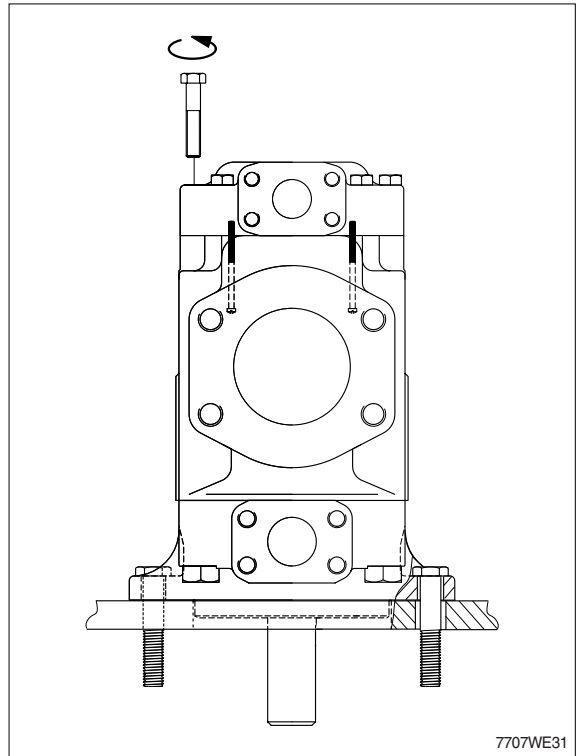

- (3) Remove the end cap (P2 cartridge will come with it).
 - ※ Cartridge : Be careful as some items could fall if the retaining cartridge bolts are totally loose or broken.
 - ※ The seal(34) usually stays in the rear cap.

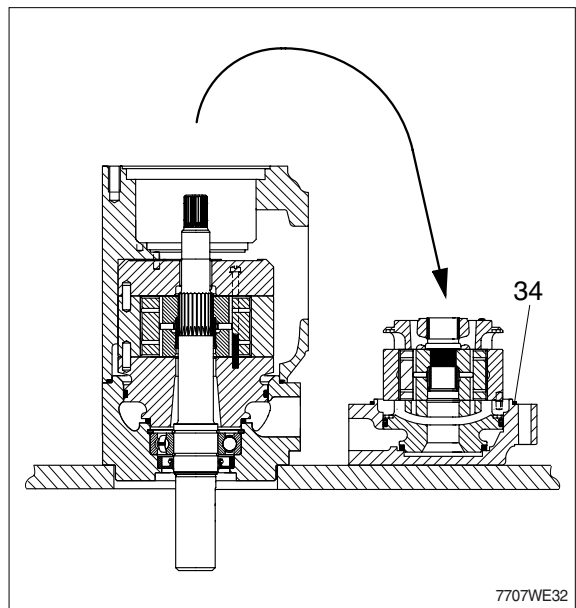

(4) Disassemble the P2 cartridge/end cap with an extractor.

※ If you want to continue the pump disassembly(P1 & shaft), go to page 6-65.

※ If you want to reassemble the P2 cartridge, go to page 6-66.

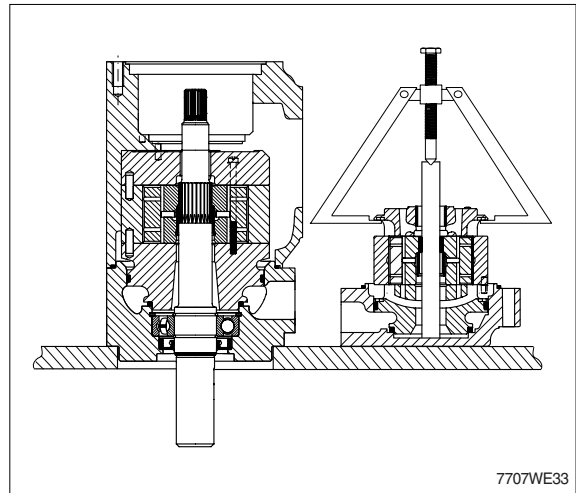

(5) Put two screws in the housing and flip the pump (housing + P1 assy).

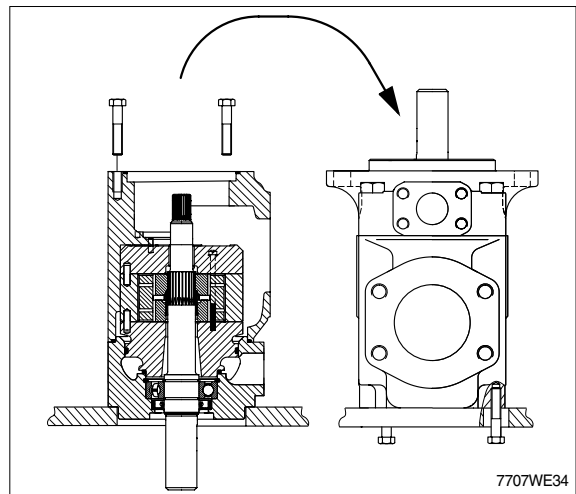

(6) Remove the bolts.

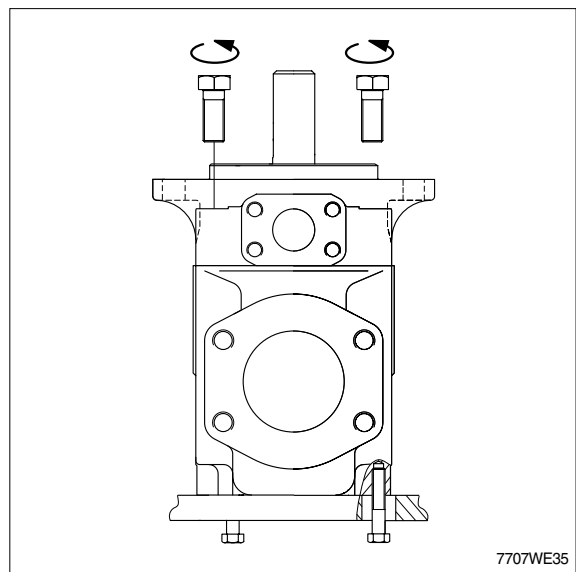

(7) Remove the front cap.

- ※ P1 cartridge will come with the front cap / shaft assembly.

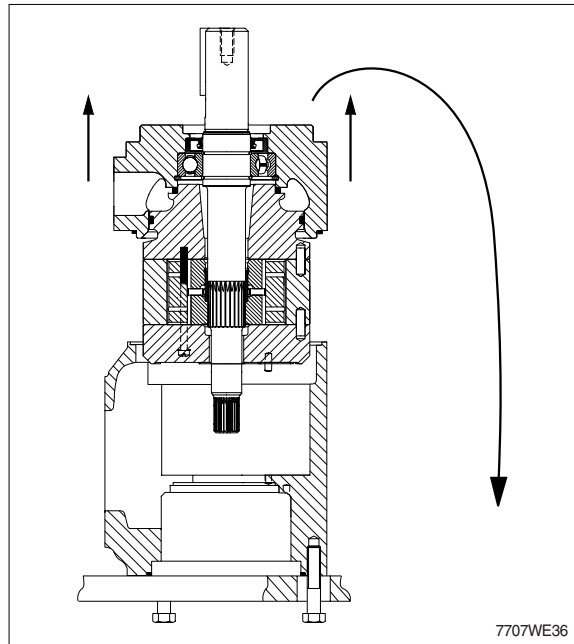

(8) Disassemble the P1 cartridge / front cap with an extractor.

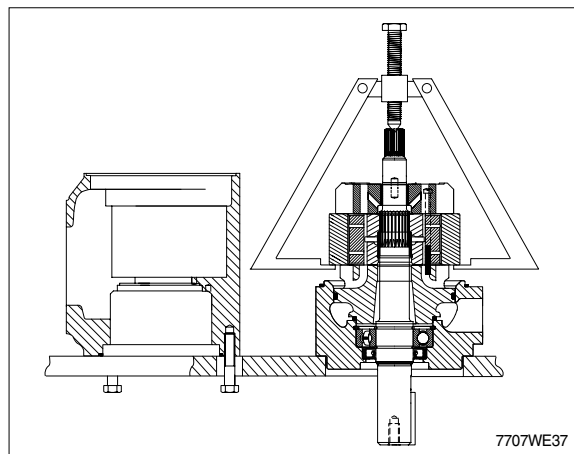

A : Remove the retaining ring

B : Extract the shaft / bearing assembly.

- ※ Take a protection cone to prevent seal damage.
If you don't, change the shaft seal.
- ※ If not new, the shaft seal should be replaced.
- ※ If the shaft \varnothing is bigger than the shaft seal \varnothing , please contact HYUNDAI.

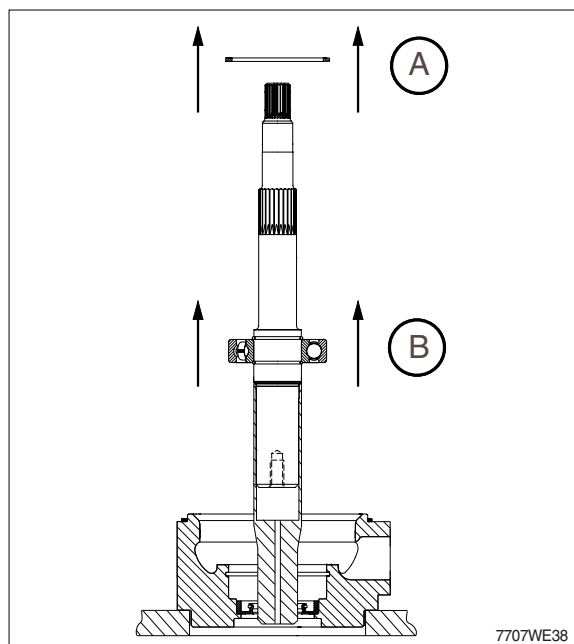

(9) The pump is now disassembled.

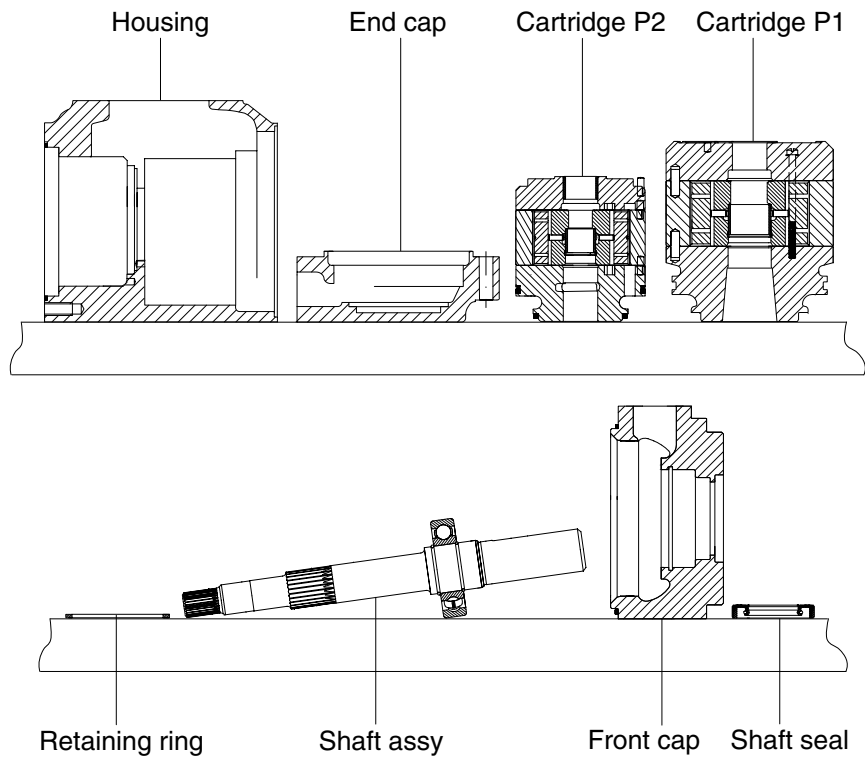

7707WE39

4) ASSEMBLY

(1) Fit the cartridge P1 into the housing.

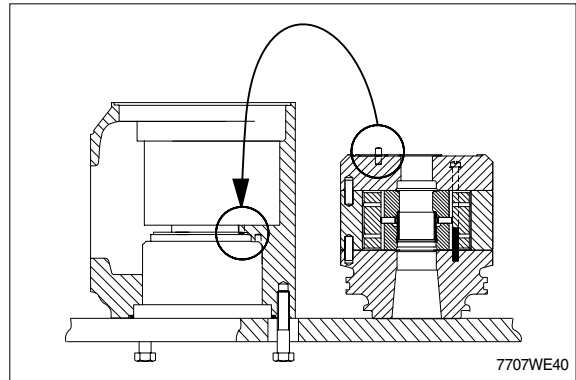

7707WE40

(2) Check if the dowel pin is in its position in the housing by trying to rotate the cartridge.

- ※ If the cartridge does rotate, the dowel pin is not in the hole.
Take the cartridge out and try again.

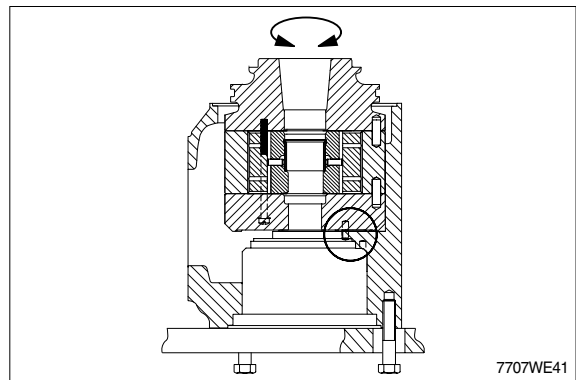

7707WE41

- A : Protective cone on the shaft assembly.
 - B : Shaft assembly + protective cone into the front cap. Slightly rotate the shaft to avoid the shaft seal lip(s) to be deteriorated.
 - C Retaining ring into the front cap.
- To avoid damaging the shaft seal do not
- ※ forget to put a protective cone on the shaft.

Push on the external bearing cage.

- ※ If the shaft ϕ is bigger than the shaft seal
- ※ ϕ , please contact HYUNDAI.

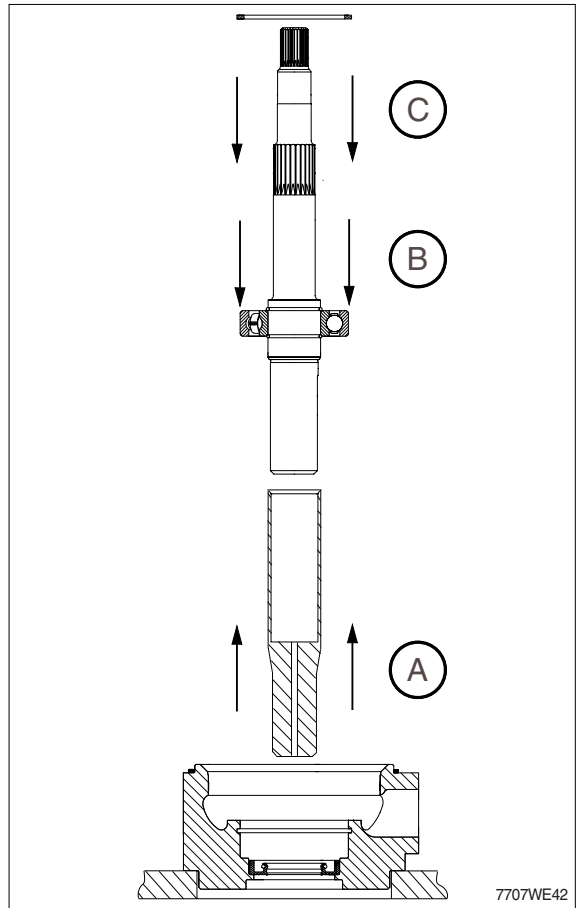

(3) Assemble the front cap assy on the housing & cartridge assy.

- ※ Position the shaft / front cap assy only if the cartridge is well positioned, dowel pin in the housing dowel pin hole.
- ※ Put some grease on the seals to prevent them from moving.

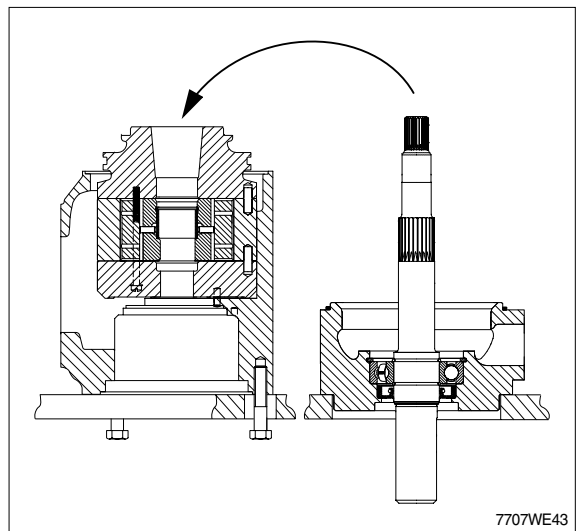

- ① Always check if the shaft rotates freely.
If not, disassemble and go back to the previous step.
- ② Check the porting configuration.
- ③ Tighten the 4 bolts.

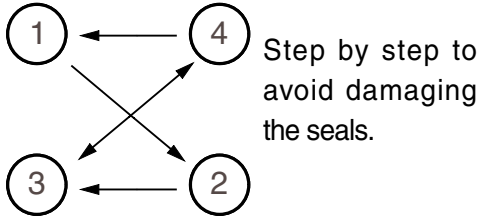

- ④ Always check if the shaft rotates freely.
If not, disassemble and go back to the previous step.

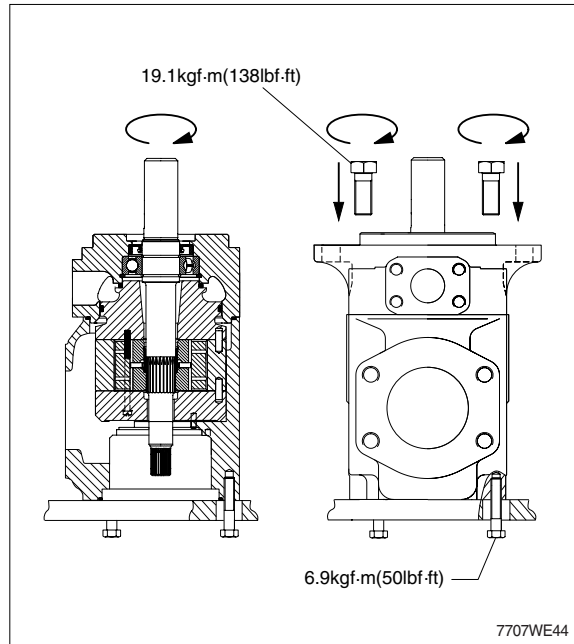

- (4) Fit the cartridge(P2) into the housing.
 - (5) Check if the dowel pin is in its position in the housing by trying to rotate the cartridge.
- ※ If the cartridge does rotate, the dowel pin is not in the hole. Take the cartridge out and try again.

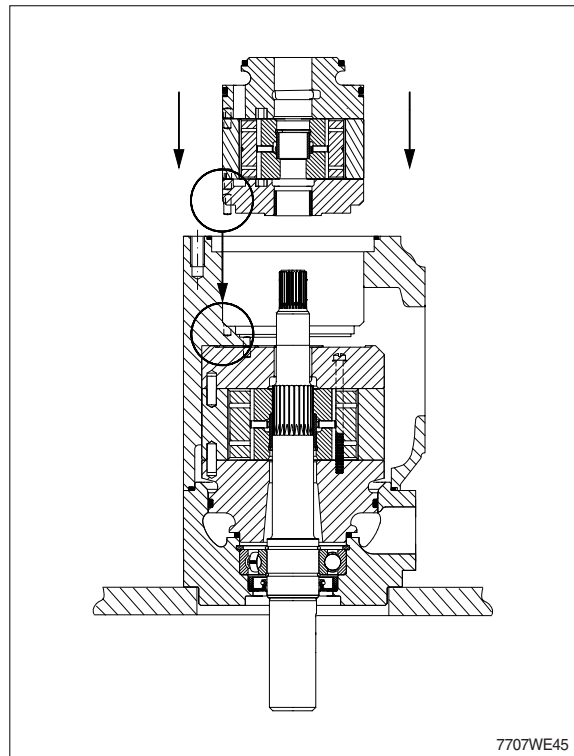

(6) Assemble the end cap on the housing assy.

- ※ Position the shaft / front cap assy only if the cartridge is well positioned, dowel pin in the housing dowel pin hole.
- ※ Put some grease on the seals to prevent them from moving.
- ※ Always check if the shaft rotates freely. If not, disassemble and go back to the

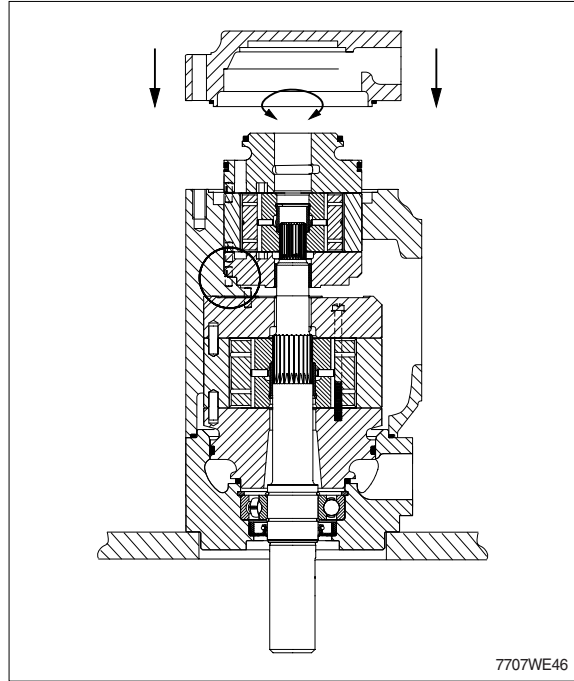

(7) Final assembly

- ① Always check if the shaft rotates freely. If not, disassemble and go back to the previous step.
- ② Check the porting configuration.
- ③ Tighten the 4 or 7 bolts.

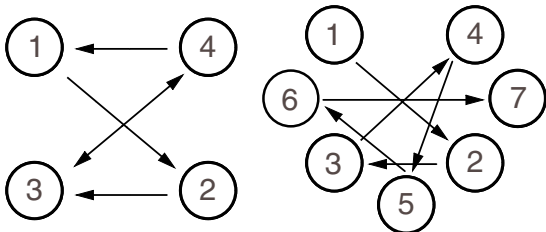

- ④ Step by step to avoid damaging the seals.
 - Tightening torque
 - Mounting cap : 19.1kgf · m(138lbf · ft)
 - End cap : 6.9kgf · m(50lbf · ft)
- ⑤ Always check if the shaft rotates freely. If not, disassemble and go back to the previous step.

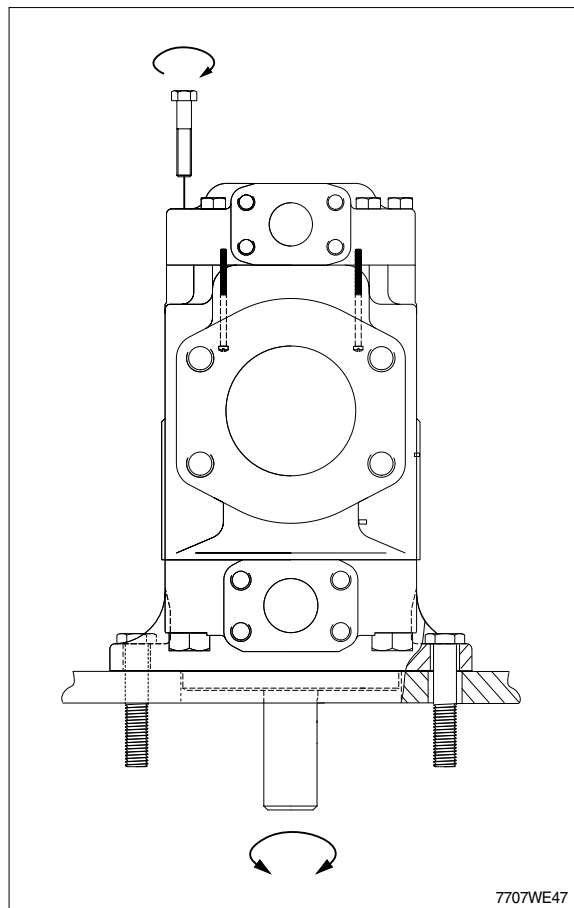

2. MAIN CONTROL VALVE

1) STRUCTURE

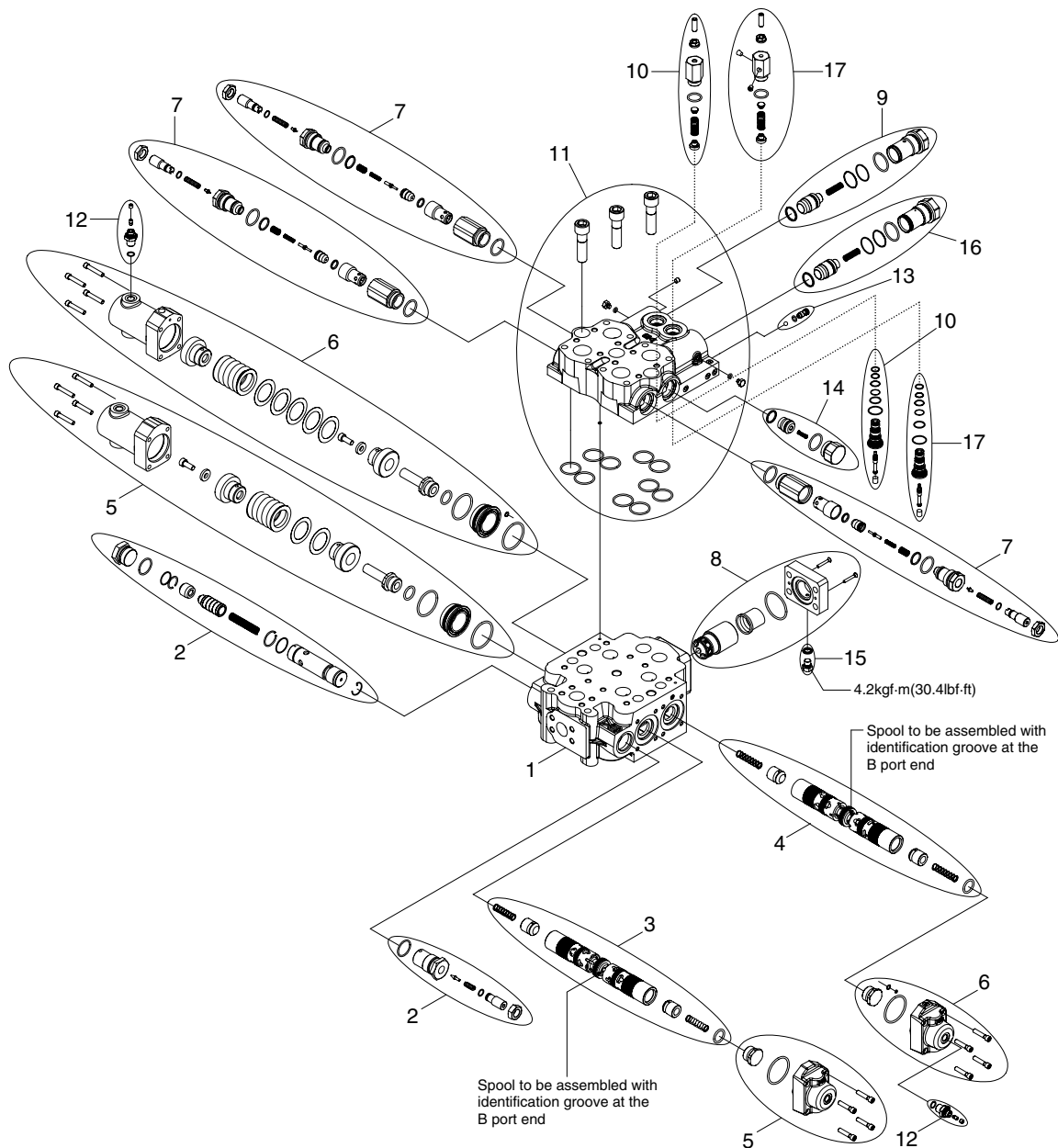

7707WE50

- | | | | |
|---|--|----|---|
| 1 | Housing group | 10 | Pilot valve assembly |
| 2 | Main relief valve assembly | 11 | Pilot operated float check block assembly |
| 3 | Double acting spool(Bucket) | 12 | Adaptor & check valve |
| 4 | Double acting spool(Boom) | 13 | Shuttle valve assembly |
| 5 | Bucket spool centering | 14 | Anti-cavitation check valve assembly |
| 6 | Boom spool centering | 15 | 1/4 " BSPP plug |
| 7 | Combined overload & anti-cavitation assembly | 16 | Check valve assembly |
| 8 | Back pressure valve | 17 | Pilot valve assembly |
| 9 | Check valve assembly | | |

2) DISASSEMBLY AND ASSEMBLY

- ※ Ensure that the machine is in a safe condition with no suspended loads or trapped pressure within the system before removing any pipework or component.
Servicing must only be carried out by trained personnel.

(1) MAIN RELIEF VALVE (Item 2)

① Removal

Unscrew both the pilot assembly and the plug from both ends of the relief valve. The main stage assembly must be driven or pressed out in the direction of the pilot assembly using a soft drift.

② Refitting

Lubricate sleeve and assemble by pressing into housing until detent ring (12) locates on housing. Fit the pilot assembly and end cap.

③ Adjusting

The main relief valve must be adjusted to the required setting when the machine is recommissioned.

Adjustment is made by first unscrewing the adjuster (1) until there is no load on the pilot spring (10).

Select a machine service to its end stop.

Screw in the adjuster until the correct pressure setting is measured at the valve inlet, account must be taken for the effect of back pressure on the measured setting.

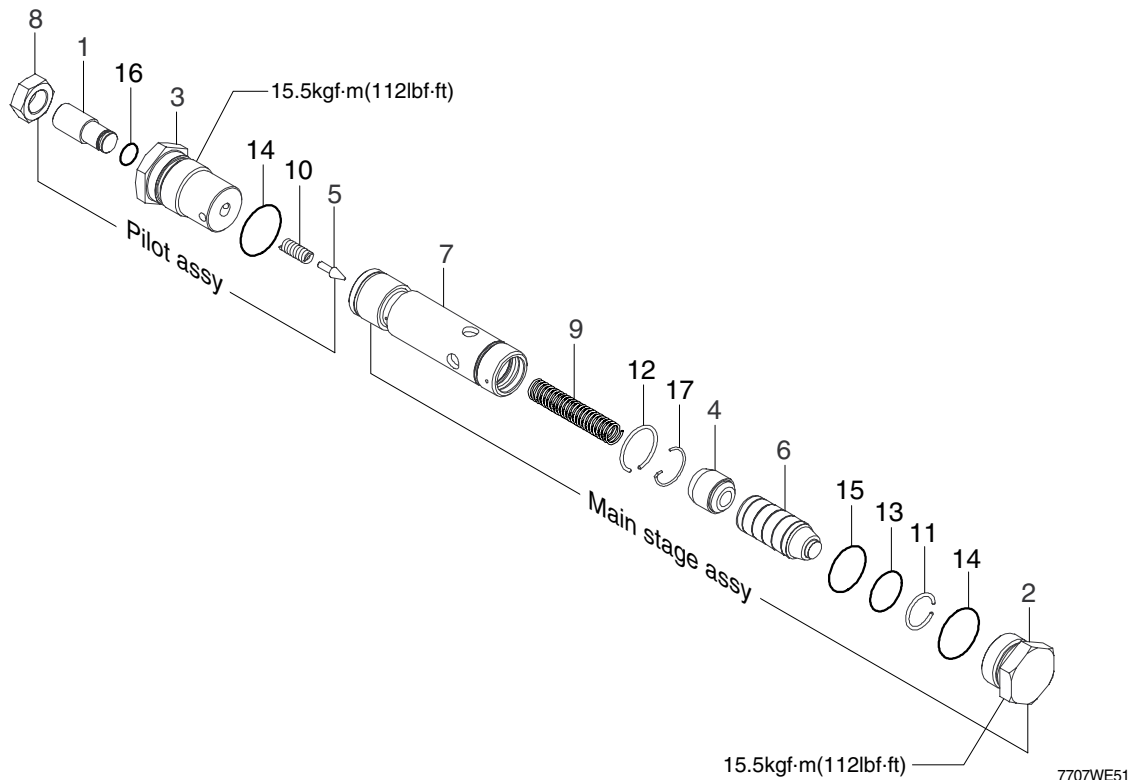

1	Adjusting screw	7	Sleeve	13	O-ring
2	Plug cap	8	Lock nut	14	O-ring
3	Cap	9	Spring	15	O-ring
4	Seat	10	Spring	16	O-ring
5	Poppet	11	Detent ring	17	Orifice wire
6	Plunger	12	Detent ring		

(2) DOUBLE ACTING SPOOL(Item 3, 4)

Control spools are not replaceable as they are individually sized to suit the housing. When removing and refitting spools ensure that they are refitted into the correct bore and correctly orientated as shown by the identification groove location on the valve assembly drawing.

- | | |
|-----------|----------|
| 1 Spool | 3 Spring |
| 2 Plunger | 4 O-ring |

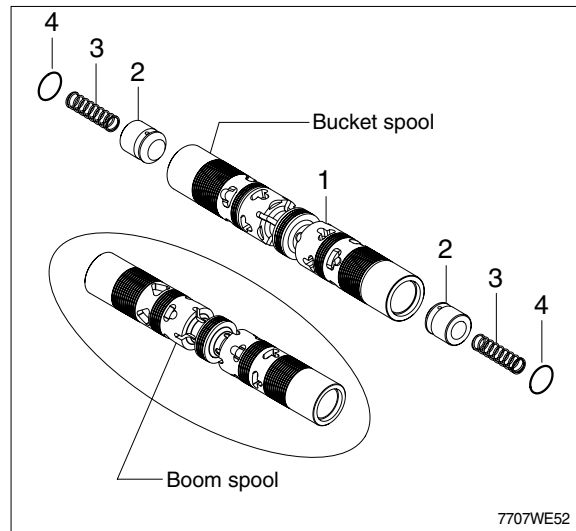

(3) BUCKET SPOOL CENTERING(Item 5)

Remove 4 retaining screws(8) from the spring centring end. Remove the cover(1) and withdraw the spring pack and spool from the valve.

Hold the spool in a suitable soft clamp being careful not to damage the spool surface or bend the spool. Remove the spool caps from the spool. The replacement assembly is supplied with the spring set to the correct load. Refit the spool caps to the specified torque using Loctite 542 or similar medium strength oil tolerant thread locking product.

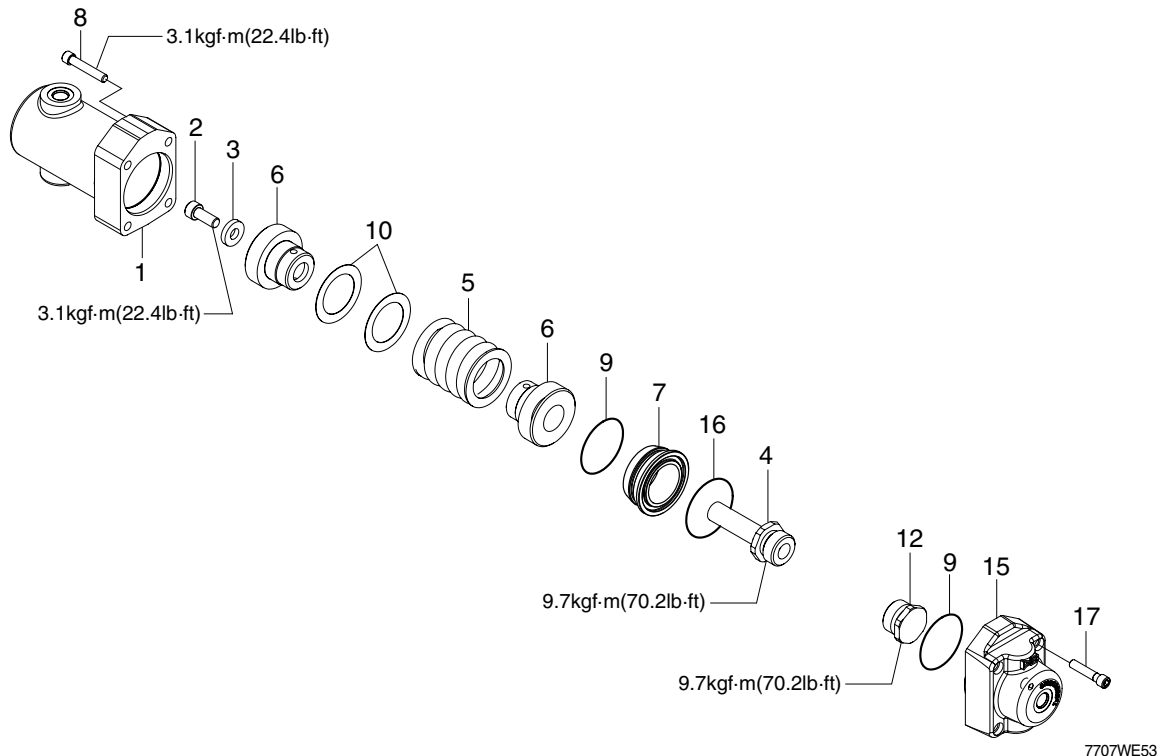

- | | | |
|-------------|---|--------------|
| 1 Cover | 6 Spring retainer | 12 Spool cap |
| 2 Cap screw | 7 Seal retainer | 15 Cover |
| 3 Washer | 8 Cap screw | 16 O-ring |
| 4 Spool cap | 9 O-ring | 17 Cap screw |
| 5 Spring | 10 Shim(0.020, 0.010, 0.005, 0.002inch) | |

(4) BOOM SPOOL CENTERING(Item 6)

Remove 4 retaining screws(8) from the spring centering end. Remove the cover(1) and withdraw the spring pack and spool from the valve.

Hold the spool in a suitable soft clamp being careful not to damage the spool surface or bend the spool. Remove the spool caps from the spool. The replacement assembly is supplied with the spring set to the correct load. Refit the spool caps to the specified torque using loctite 542 or similar medium strength oil tolerant thread locking product.

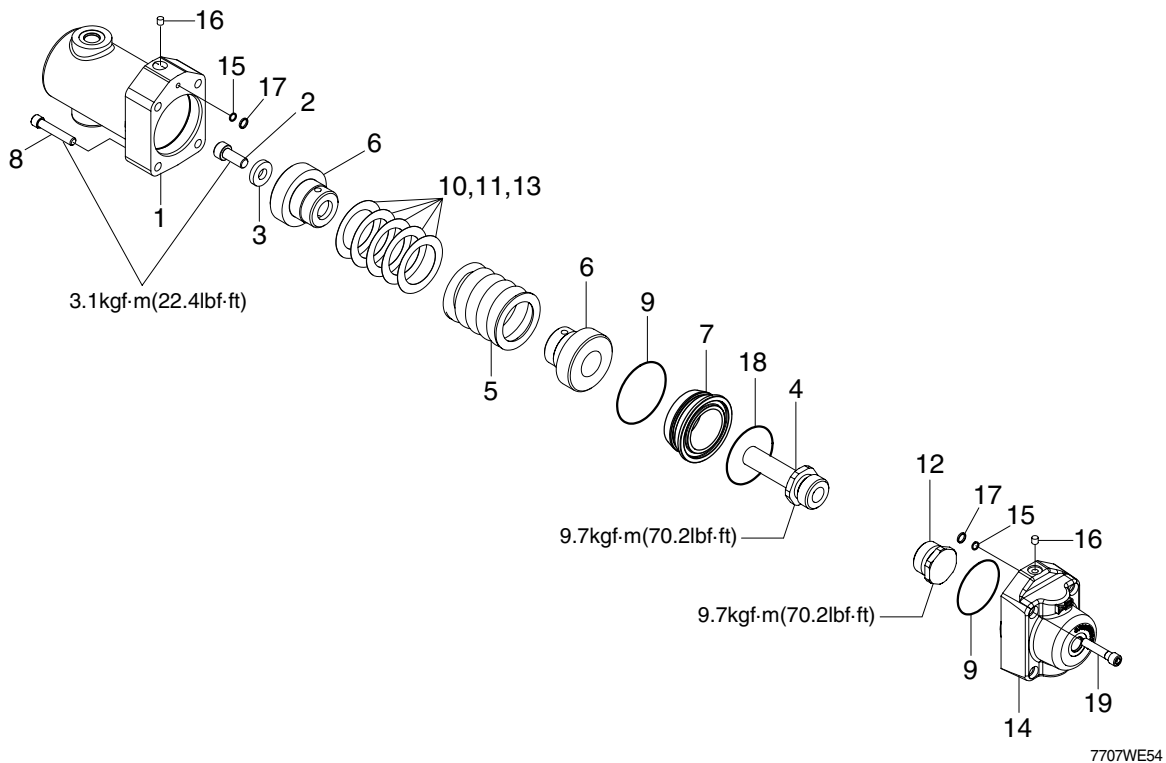

- | | | | | | |
|---|-----------------|----|----------------------|----|--------------|
| 1 | Cover | 8 | Cap screw | 14 | Cover |
| 2 | Cap screw | 9 | O-ring | 15 | O-ring |
| 3 | Washer | 10 | Shim(0.020inch, 2EA) | 16 | Plug |
| 4 | Spool cap | 11 | Shim(0.005inch, 2EA) | 17 | Back up ring |
| 5 | Spring | 12 | Spool cap | 18 | O-ring |
| 6 | Spring retainer | 13 | Shim(0.005inch, 1EA) | 19 | Cap screw |
| 7 | Seal retainer | | | | |

(5) COMBINED OVERLOAD AND ANTI-CAVITATION(Item 7)

This is a non servicable item and a replacement unit factory set to the correct setting should be fitted. Inspect seat in valve housing for damage before refitting.

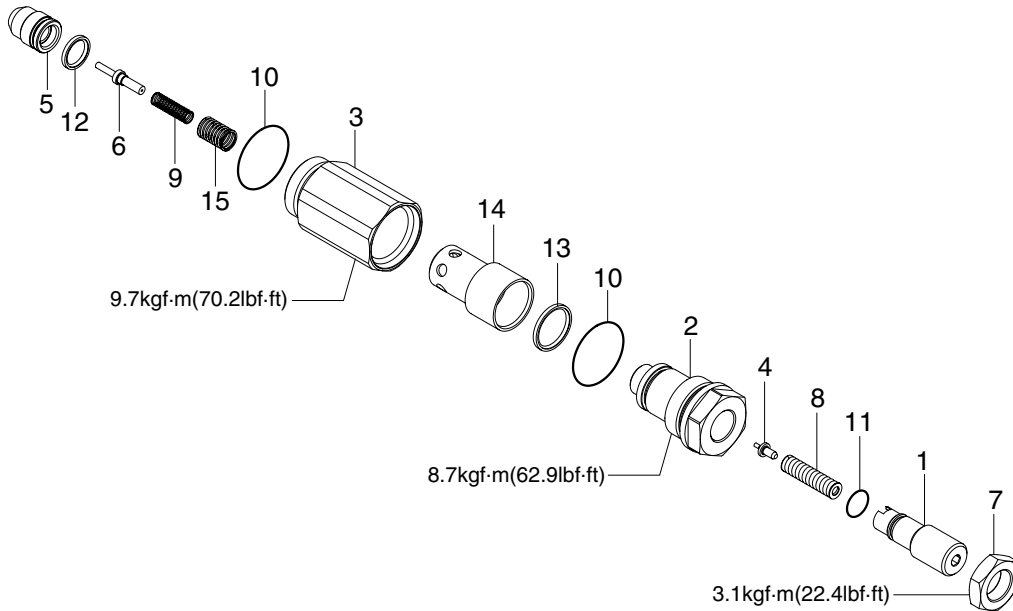

7707WE55

- | | | | | | |
|---|-----------------|----|--------------|----|----------------------------|
| 1 | Adjusting screw | 6 | Pilot pin | 11 | O-ring |
| 2 | Pilot housing | 7 | Thin nut | 12 | Composite piston seal |
| 3 | A/C housing | 8 | Pilot spring | 13 | Composite piston seal |
| 4 | Pilot poppet | 9 | Spring | 14 | A/C check and main housing |
| 5 | Main plunger | 10 | O-ring | 15 | Return spring |

(6) BACK PRESSURE VALVE(Item 8)

This assembly is retained by screws(5) when replacing the check valve(2) ensure that it is free to slide in the housing before refitting the blanking plate.

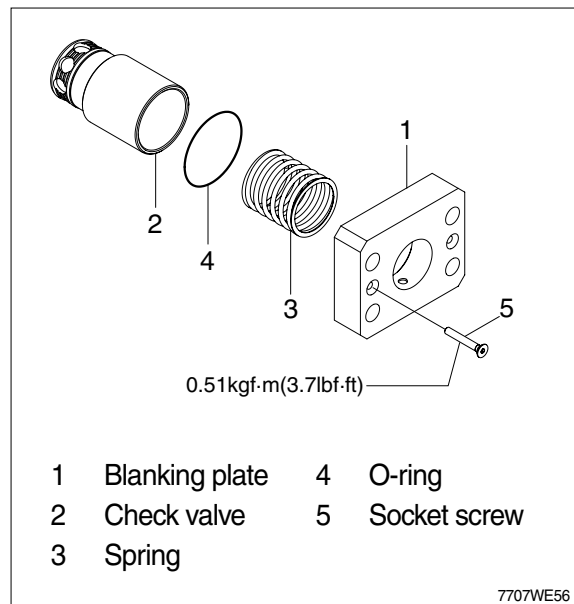

- | | | | |
|---|----------------|---|--------------|
| 1 | Blanking plate | 4 | O-ring |
| 2 | Check valve | 5 | Socket screw |
| 3 | Spring | | |

7707WE56

(7) CHECK VALVE ASSEMBLY (Item 9, 16)

This is a non servicable item and a replacement unit should be fitted.

Ensure that orifice in check valve(1) is clear when refitting. Inspect seat in float check block for damage before refitting.

- | | | | |
|---|-------------------|---|-----------------------|
| 1 | Float check valve | 6 | Spring |
| 2 | Housing | 7 | Composite piston seal |
| 4 | O-ring | 8 | O-ring |
| 5 | Back up ring | | |

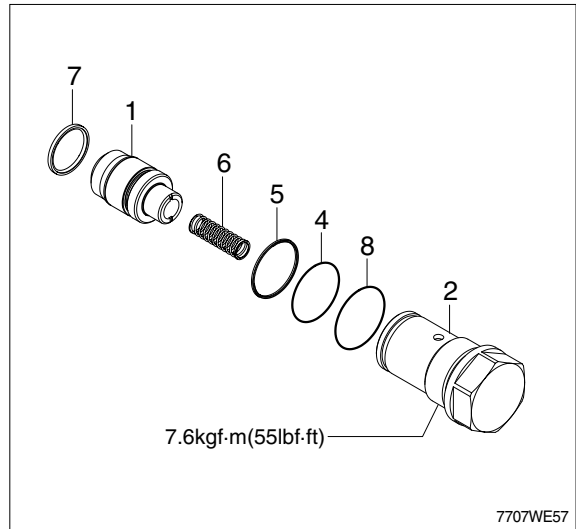

(8) PILOT VALVE ASSEMBLY (Item 10)

The replacement of this item requires that the float check block is first removed from the valve.

This is a non servicable item and a replacement unit should be fitted.

The logic spool is individually sized to the housing bore in item 12.

Replacement assemblies are supplied factory set.

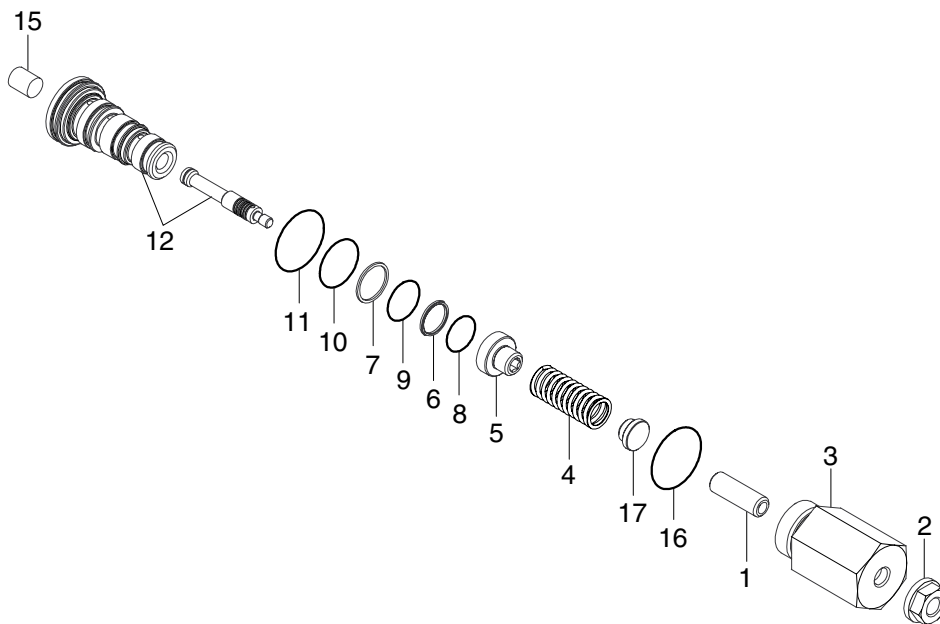

- | | | | | | |
|---|------------------|----|--------------|----|----------------------|
| 1 | Socket set screw | 6 | Back up ring | 11 | O-ring |
| 2 | Lock nut | 7 | Back up ring | 12 | Logic seat and spool |
| 3 | Spring body | 8 | O-ring | 15 | Plug |
| 4 | Spring | 9 | O-ring | 16 | O-ring |
| 5 | Spring retainer | 10 | O-ring | 17 | Spring guide |

(9) PILOT OPERATED FLOAT CHECK BLOCK ASSEMBLY (Item 11)

Remove the three retaining screws(2) and lift the block from the main housing.
Do not slide the block across the face as this may damage the sealing face and seals.

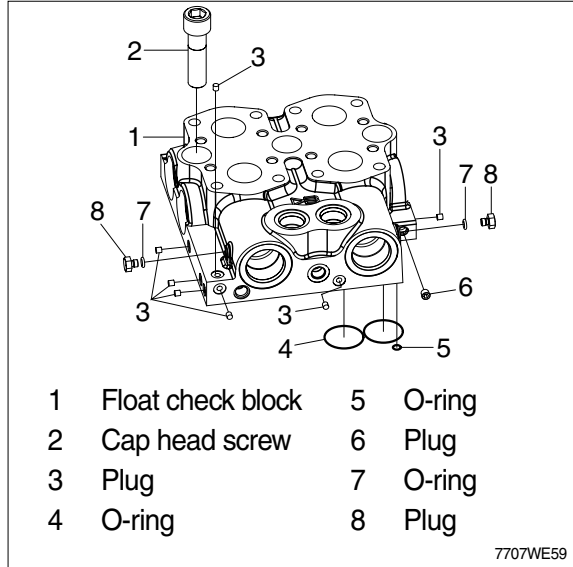

(10) ADAPTER+ORIFICE SCREW+CHECK VALVE (Item 12)

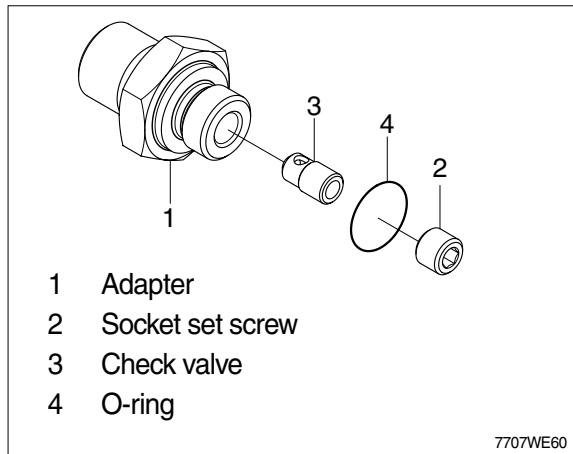

(11) SHUTTLE VALVE ASSEMBLY (Item 13)

This is non servicable item and a replacement unit should be fitted.
Inspect seat in float check block for damage before refitting.

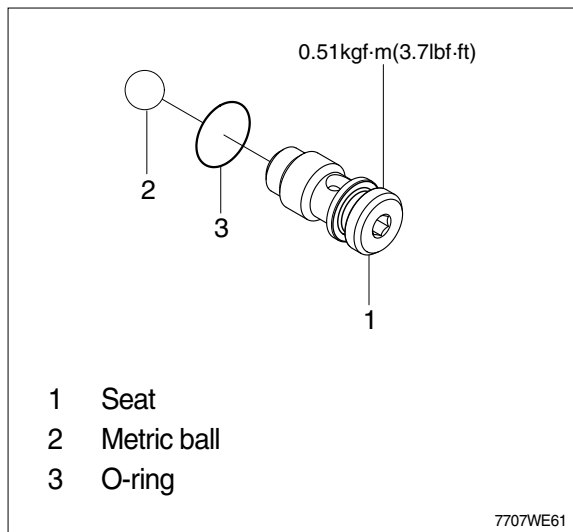

(12) A/C CHECK VALVE ASSEMBLY (Item 14)

This is a non servicable item and a replacement unit should be fitted. Inspect seat in float check block for damage before refitting.

- | | | | |
|---|-------------|---|-------------|
| 1 | Body | 4 | Piston seal |
| 2 | Check valve | 5 | O-ring |
| 3 | Spring | | |

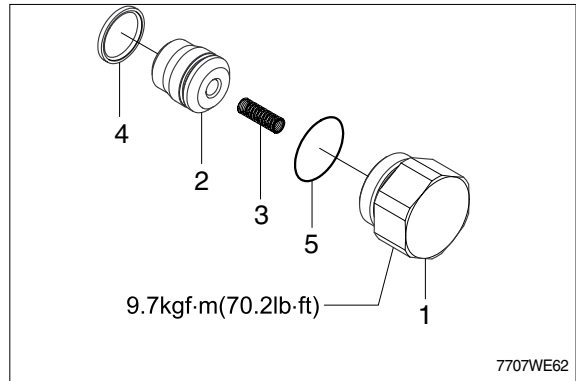

(13) PILOT VALVE ASSEMBLY (Item 17)

The replacement of this item requires that the float check block is first removed from the valve.

This is a non servicable item and a replacement unit should be fitted. The logic spool is individually sized to the housing bore in item 12.

Replacement assemblies are supplied factory set.

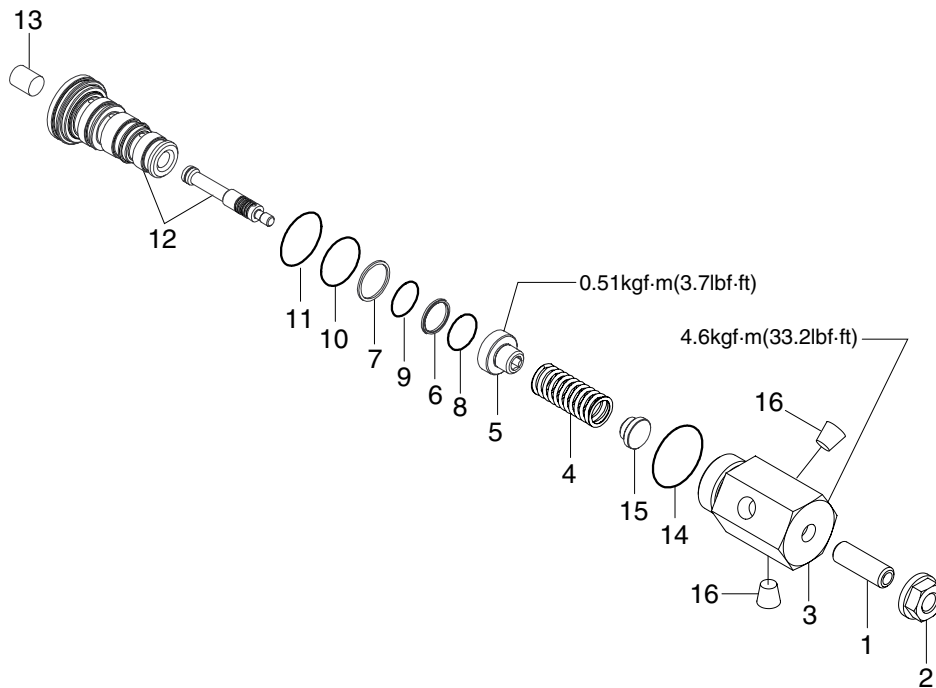

- | | | | | | |
|---|------------------|----|--------------|----|----------------------|
| 1 | Socket set screw | 7 | Back up ring | 12 | Logic seat and spool |
| 2 | Hexagon nut | 8 | O-ring | 13 | Plug |
| 3 | Spring body | 9 | O-ring | 14 | O-ring |
| 4 | Spring | 10 | O-ring | 15 | Spring guide |
| 5 | Spring retainer | 11 | O-ring | 16 | Plug |
| 6 | Back up ring | | | | |

3. REMOTE CONTROL VALVE

1) STRUCTURE

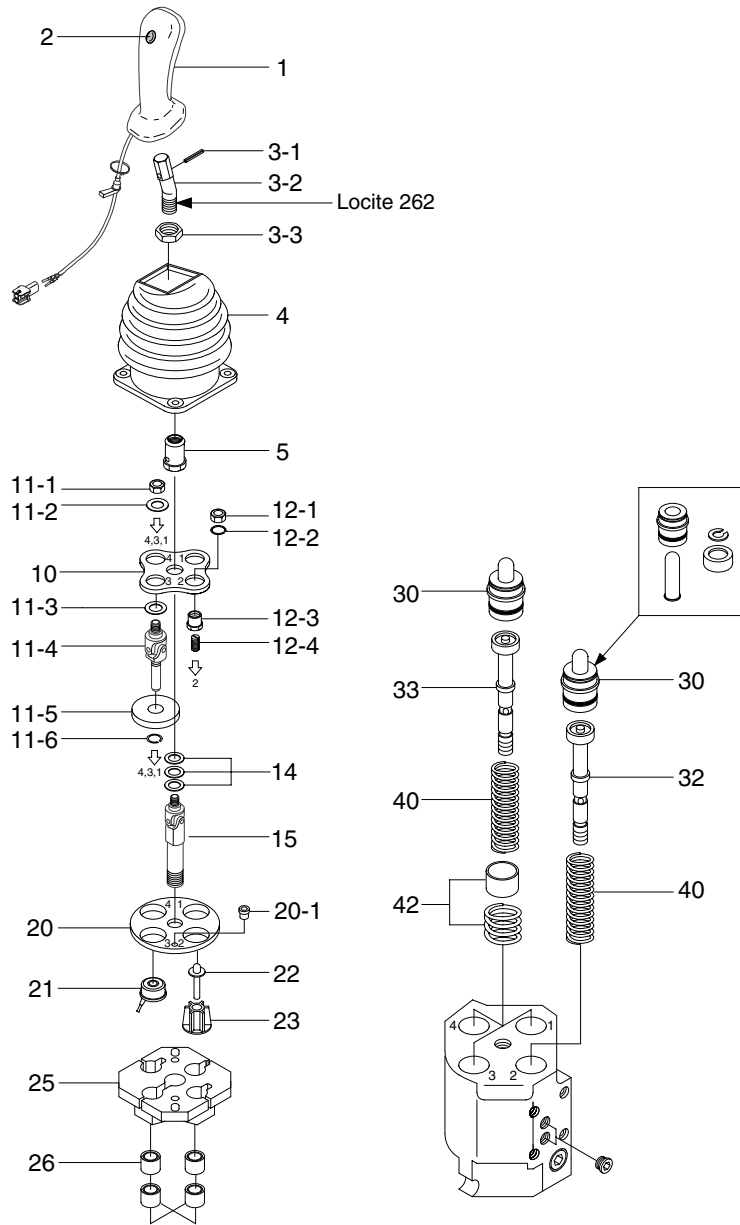

7707WE64

- | | | | | | |
|------|------------------|------|------------------------|-------|--------------------------|
| 1 | Handle | 11-4 | Cardan | 21 | Solenoid |
| 2 | Push button | 11-5 | Armature | 22 | Intermediary plunger kit |
| 3-1 | Locking pin | 11-6 | Spring ring | 23 | Intermediary plunger |
| 3-2 | Bent lever | 12-1 | Counter nut | guide | |
| 3-3 | Nut | 12-2 | Spring ring | 25 | Electric bracket |
| 4 | Rubber boot | 12-3 | Switch plate screw | 26 | Bushing |
| 5 | Locking nut | 12-4 | Press screw | 30 | Plunger kit |
| 10 | Cardan bracket | 14 | Shims(0.1, 0.2, 0.5mm) | 32 | Regulation unit |
| 11-1 | Self-locking nut | 15 | Cardan | 40 | Return spring |
| 11-2 | Washer | 20 | Flange | 42 | Prefeeling point kit |
| 11-3 | Washer | | | | |

2) DISASSEMBLY AND ASSEMBLY

(1) PUSH BUTTEN

- ※ The remote control valve does not need to be removed from the machine to perform this operation.
Remove worn pushbutton using a small screwdriver.
The installation of new elements is performed without any special tools; the parts are simply pressed into place.

(2) RUBBER BOOT

- ① Remove the remote control valve from the machine or free the valve by unscrewing the 4 screws fixing the plate in order to release the electrical cable.
 - Assembly
Torque : 1.02kgf · m(7.4lbf · ft)Hold the remote control valve using a vice or a vice-grip wrench(clamp onto the body).
- ※ The pilot unit does not need to be removed from the machine to release the cable. However, it is recommended to lift the control unit by undoing the 4 fixing screws on the arm rest.
- ※ It is unnecessary to remove the units with no electrical functions.
- ② Lift and turn the boot inside out.
- ③ Remove the grommet(7) from its emplacement to free the cable.
- ④ Loosen the handle mounting nut(3-3) using a 19mm open-end wrench.
 - Assembly : torque 4.08kgf · m(29.5lbf · ft)
- ⑤ Unscrew and remove the handle(1).
 - Assembly
- Add loctite 262 onto the lever thread
- Torque : 4.08kgf · m(29.5lbf · ft)
- ⑥ Replace the faulty rubber boot(4) with a new one.
- ⑦ Replace the handle(1) following the disassembly instructions in reverse order.

(3) HANDLE

- ① Clamp the threaded section of the lever(3-2) in a vice fitted with V-shaped vice clamp.
- ② Remove the pin(3-1) using a 5mm pin driver.
- ③ Replace the lever(3-2) onto the new handle(1) and secure it with the pin(3-1) using a 5mm pin driver.
- ※ Respect the position of the curved lever to ensure that the handle is correctly oriented as indicated by the machine's technical specifications.
- ④ Replace the nut(3-3) on the threaded section and replace the boot(4).

(4) DETENT CARDAN BRACKET KIT

- ※ Remove the 2 grommets(20-1) from the flange (20).
- ※ Place centering sleeves V & W to avoid damaging the cardan knuckles while loosening the nuts.
- ※ Unscrew the locking nut(5) using a 23mm open-end wrench.
 - Assembly : Torque $4.08 \pm 0.4 \text{kgf} \cdot \text{m}$
($29.5 \pm 2.9 \text{lbf} \cdot \text{ft}$)

- ① Unscrew the self-locking nut(11-1) using a 13mm open-end wrench.
 - Assembly
 - Torque $1.02 \text{kgf} \cdot \text{m}$ ($7.4 \text{lbf} \cdot \text{ft}$)
 - Place centering sleeves(V-W) to avoid damaging the cardan knuckles while screwing the nuts.
- ② Remove : - Friction washer(11-2)
 - Friction washer(11-3)
 - Cardan/armature assembly (11-4 ~ 11-6)

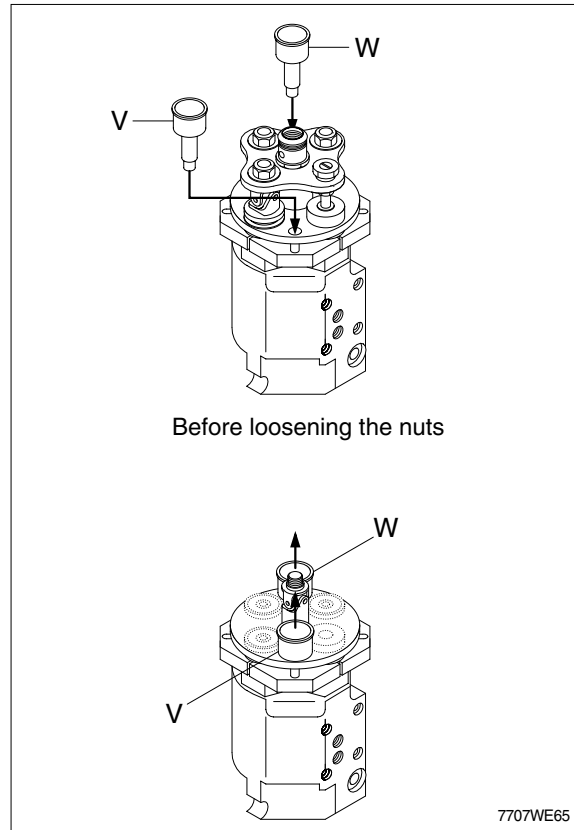

(5) NON-DETENT PLUNGER KIT

- ① Unscrew the self-locking nut(12-1) using a 13mm open-end wrench.
 - Reassembly : - Torque $1.02 \text{kgf} \cdot \text{m}$ ($7.4 \text{lbf} \cdot \text{ft}$)
 - Place centering sleeves(V-W) to avoid damaging the cardan knuckles while screwing the nuts.
- ② Undo the snap ring(12-2) using a flat-end screwdriver.
- ③ Remove the screw assembly(12-3, 12-4)

(6) CARDAN

- ① Remove the centering sleeves **V** & **W**.
- ② Remove the cardan bracket(10) and the shims(14).
- ③ Unscrew the cardan(15) using a 17mm open-end wrench.
 - Reassembly : - Ungrease the cardan threads
 - Add loctite 262 onto the cardan threads(both end)
 - Torque $4.08 \text{kgf} \cdot \text{m}$ ($29.5 \text{lbf} \cdot \text{ft}$)

(7) SOLENOID AND CONNECTOR

- ※ It is advised to mount the connector onto the solenoid cable once the remote control valve is assembled.
- ① Remove the flange(20) and the electrical bracket(25),
 - ② Remove the protecting bushes(26) from the electrical bracket(25).
 - ③ Undo the solenoid(21) from the electric bracket(25).
 - ④ Replace the solenoid.
 - ※ Clean the polar face using a piece of cloth and pay attention not to hit them.
 - ⑤ Assembly : Place the solenoid cable in its emplacement on the electric bracket before fitting the protection bushes.

(8) INTERMEDIARY PLUNGER KIT

- ① Undo the intermediary plunger guide(23).
- ② Remove and replace the intermediary plunger kit assembly(22).

(9) GUIDE / PLUNGER AND REGULATION UNIT

- ※ Beware of the plungers that might jump out due to the spring return.
- ① Remove : - Guide/plunger assembly(30).
 - Regulation unit(32/33).
 - Return spring(40).
 - Pre-feeling point kit(42).
 - ② The remote control valve is now totally disassembled.
Assemble in reverse order following the torque specification.