

SECTION 7 ELECTRICAL SYSTEM

Group 1 Component Location	7-1
Group 2 Electrical Circuit	7-3
Group 3 Monitoring System	7-21
Group 4 Electrical Component Specification	7-48
Group 5 Connectors	7-56
Group 6 Troubleshooting	7-77

SECTION 7 ELECTRICAL SYSTEM

GROUP 1 COMPONENT LOCATION

1. LOCATION 1

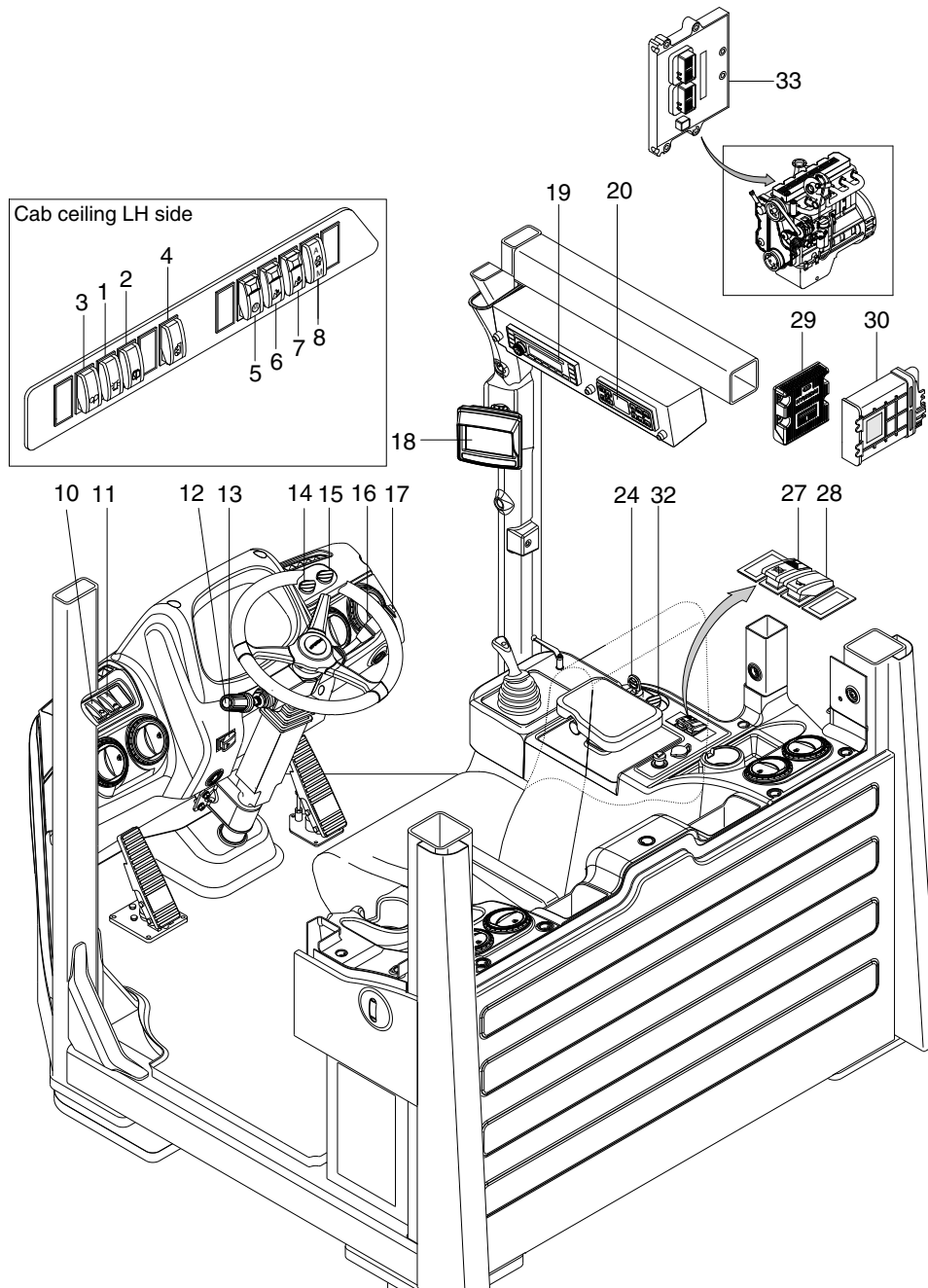

7759S7EL02B

- | | | |
|---|-------------------------------|-------------------------------|
| 1 Beacon switch (opt) | 11 Work lamp switch | 20 Aircon & heater switch |
| 2 Rear wiper / washer switch | 12 Kick down switch | 24 Starting switch |
| 3 Central grease lubrication switch (opt) | 13 Hazard switch | 27 Parking brake switch |
| 4 Mirror defrost switch | 14 T/M shift mode switch | 28 Ride control switch (opt) |
| 5 Emergency test switch (opt) | 15 Clutch cut off mode switch | 29 Machine control unit (MCU) |
| 6 Attachment lock switch (opt) | 16 Multi function switch | 30 T/M control unit (TCU) |
| 7 Attachment unlock switch (opt) | 17 Horn switch | 32 Engine mode switch |
| 8 Fan control switch | 18 Monitor | 33 Engine control unit(ECU) |
| 10 Main light switch | 19 Radio & USB player | |

2. LOCATION 2

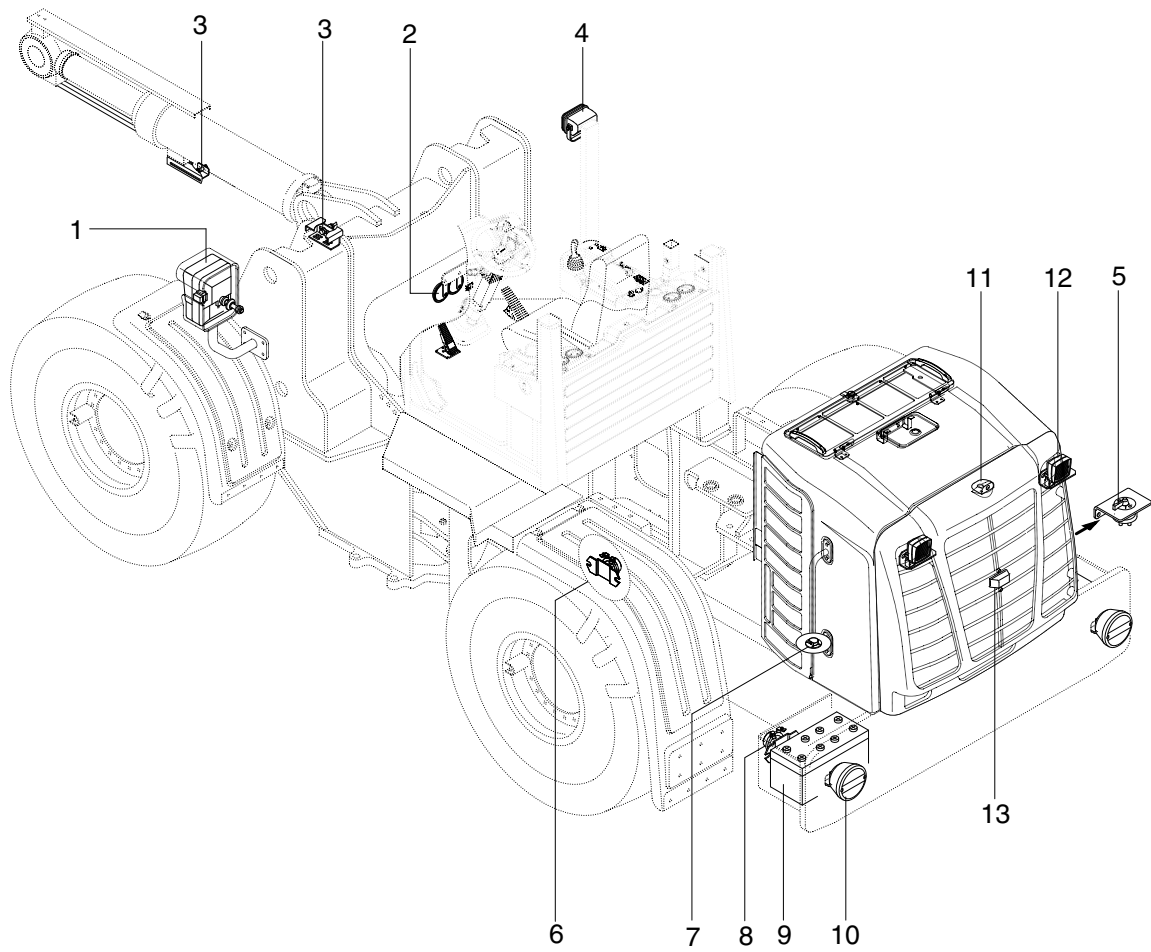

7609S7EL02-1

- | | | | | | |
|---|------------------|----|-----------------|----|-------------------|
| 1 | Head lamp | 6 | Start relay | 11 | Camera (opt) |
| 2 | Horn | 7 | Fuel sender | 12 | Work lamp |
| 3 | Proximity switch | 8 | Battery relay | 13 | Number plate lamp |
| 4 | Work lamp | 9 | Battery | | |
| 5 | Master switch | 10 | Rear combi lamp | | |