

## SECTION 6 WORK EQUIPMENT

Group 1 Structure and Function -----	6-1
Group 2 Operational Checks and Troubleshooting -----	6-35
Group 3 Tests and Adjustments -----	6-46
Group 4 Disassembly and Assembly -----	6-62

# SECTION 6 WORK EQUIPMENT

## GROUP 1 STRUCTURE AND FUNCTION

### 1. HYDRAULIC SYSTEM OUTLINE

The loader hydraulic system is a pilot operated, open center system which is supplied with flow from the fixed displacement main hydraulic pump.

The pilot control system is a low pressure, closed center hydraulic system which is supplied with flow from the first(Steering) pump.

The loader system components are :

- Main pump
- Main control valve
- Bucket cylinder
- Boom cylinders
- Pilot supply unit
- Remote control valve(Pilot control valve)
- Safety valve

The pilot unit supply consists of the pressure reducing valve, relief valve and accumulator.

Flow from the main hydraulic pump not used by the steering system leaves the flow amplifier EF port. It flows to the inlet port plate of a mono block type main control valve.

The main control valve is a tandem version spool type, open center valve which routes flow to the boom, bucket or auxiliary cylinders(Not shown) when the respective spools are shifted.

Flow from the steering pump(The first pump) is routed to the pilot supply unit where the steering pump outlet pressure is reduced to pilot circuit pressure. The pilot supply unit flow to the remote control valve.

The remote control valve routed flow to either end of each spool valve section in the main control valve to control spool stroke.

A accumulator mounted on pilot supply unit supplies a secondary pressure source to operated remote control valve so the boom can be lowered if the engine is off.

The return circuit for the main hydraulic system have return filter inside the hydraulic tank. The return filter uses a filter element and a bypass valve. The bypass valve is located in the upside of filter.

## 2. HYDRAULIC CIRCUIT

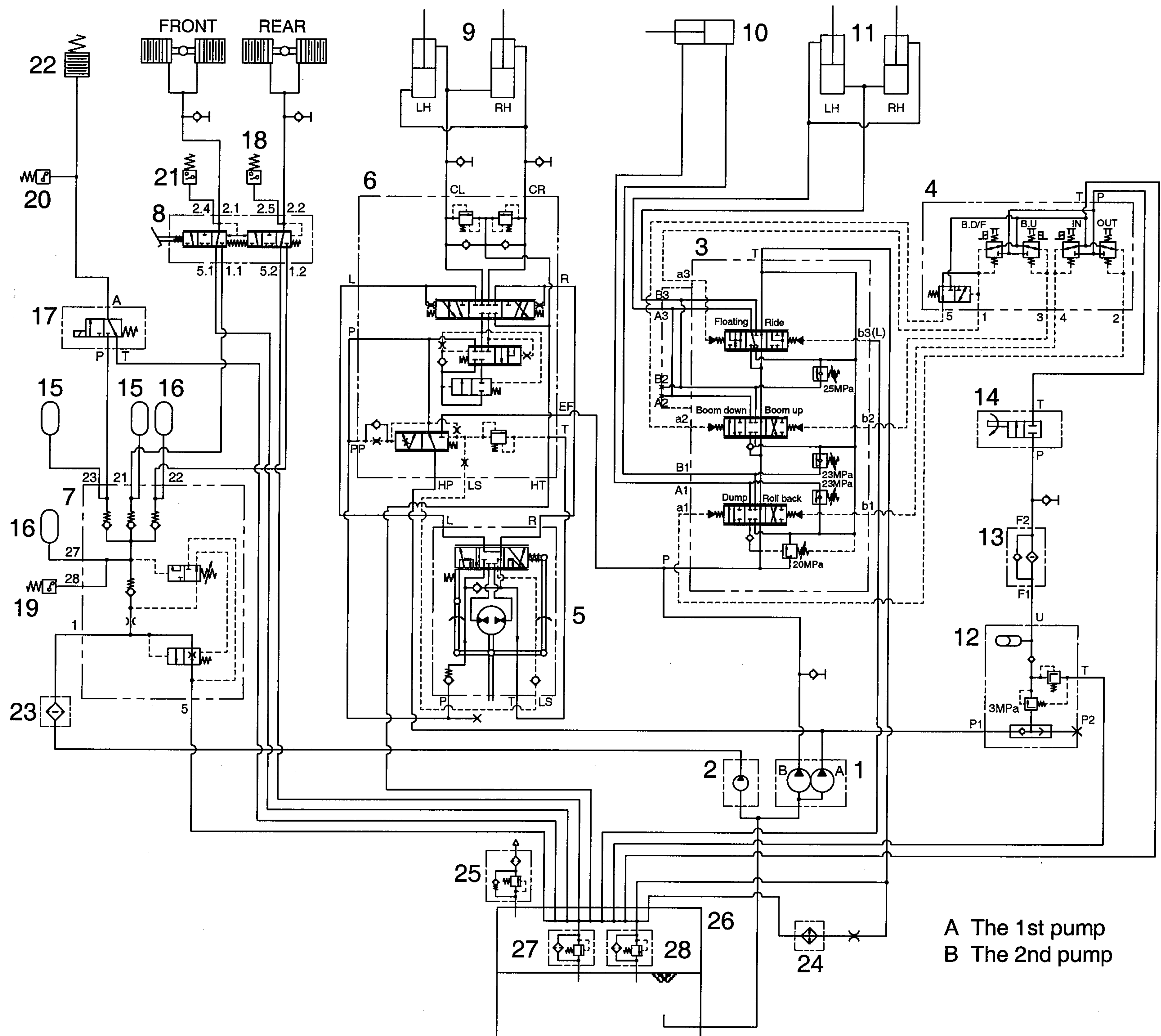

A The 1st pump  
B The 2nd pump

- |    |                      |    |                   |    |                 |
|----|----------------------|----|-------------------|----|-----------------|
| 1  | Main pump            | 11 | Boom cylinder     | 20 | Pressure switch |
| 2  | Brake pump           | 12 | Pilot supply unit | 21 | Pressure switch |
| 3  | Main control valve   | 13 | Line filter       | 22 | Parking brake   |
| 4  | Remote control valve | 14 | Safety valve      | 23 | Line filter     |
| 5  | Steering unit        | 15 | Accumulator       | 24 | Oil cooler      |
| 6  | Flow amplifier       | 16 | Accumulator       | 25 | Air breather    |
| 7  | Cut off valve        | 17 | Solenoid valve    | 26 | Hydraulic tank  |
| 8  | Brake valve          | 18 | Pressure switch   | 27 | Return filter   |
| 9  | Steering cylinder    | 19 | Pressure switch   | 28 | Bypass valve    |
| 10 | Bucket cylinder      |    |                   |    |                 |



### 3. WORK EQUIPMENT HYDRAULIC CIRCUIT

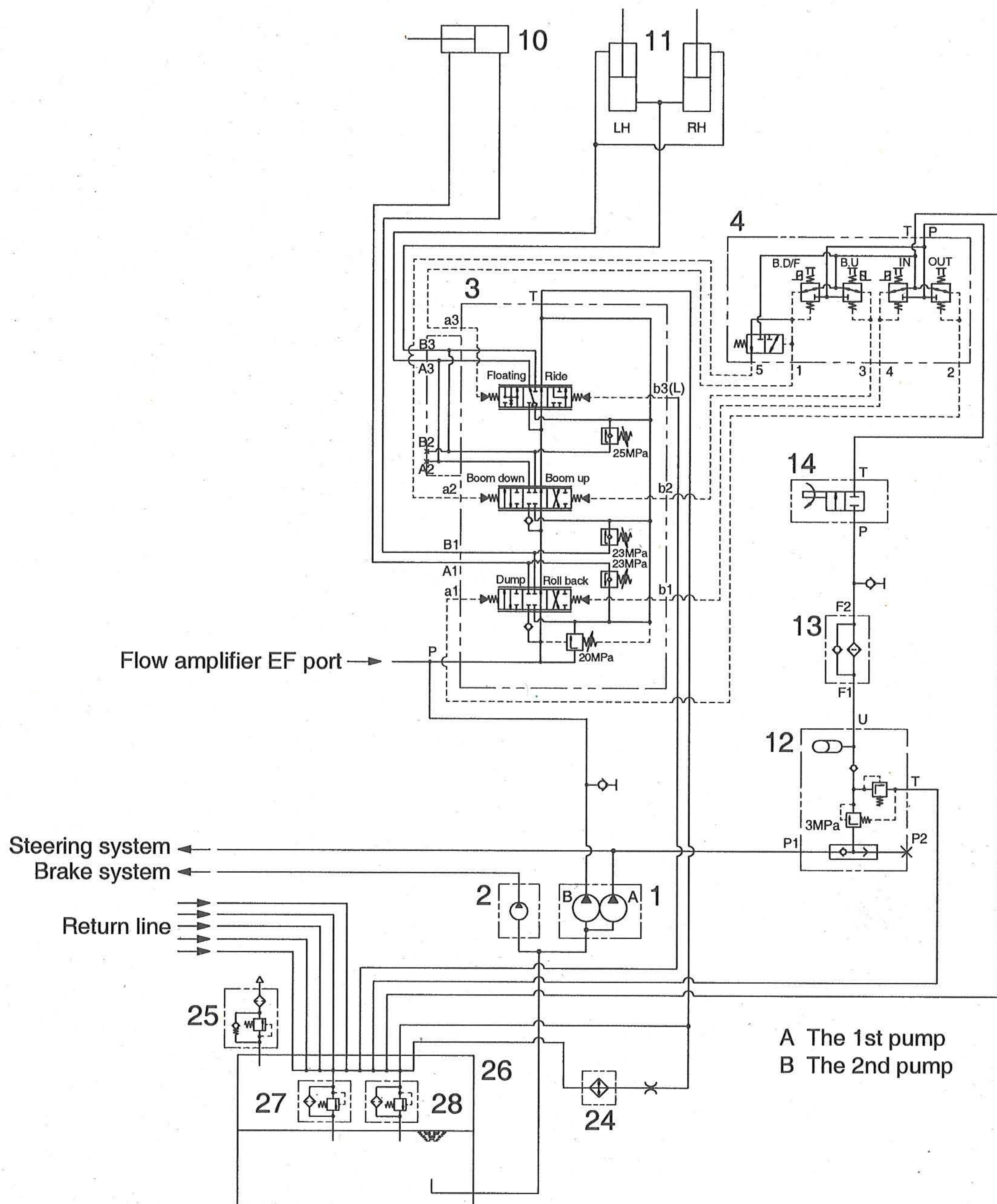

- |    |                      |    |                   |    |                |
|----|----------------------|----|-------------------|----|----------------|
| 1  | Main pump            | 11 | Boom cylinder     | 25 | Air breather   |
| 2  | Brake pump           | 12 | Pilot supply unit | 26 | Hydraulic tank |
| 3  | Main control valve   | 13 | Line filter       | 27 | Return filter  |
| 4  | Remote control valve | 14 | Safety valve      | 28 | Check valve    |
| 10 | Bucket cylinder      | 24 | Oil cooler        |    |                |



# 1) WHEN THE RCV LEVER IS IN THE RAISE POSITION

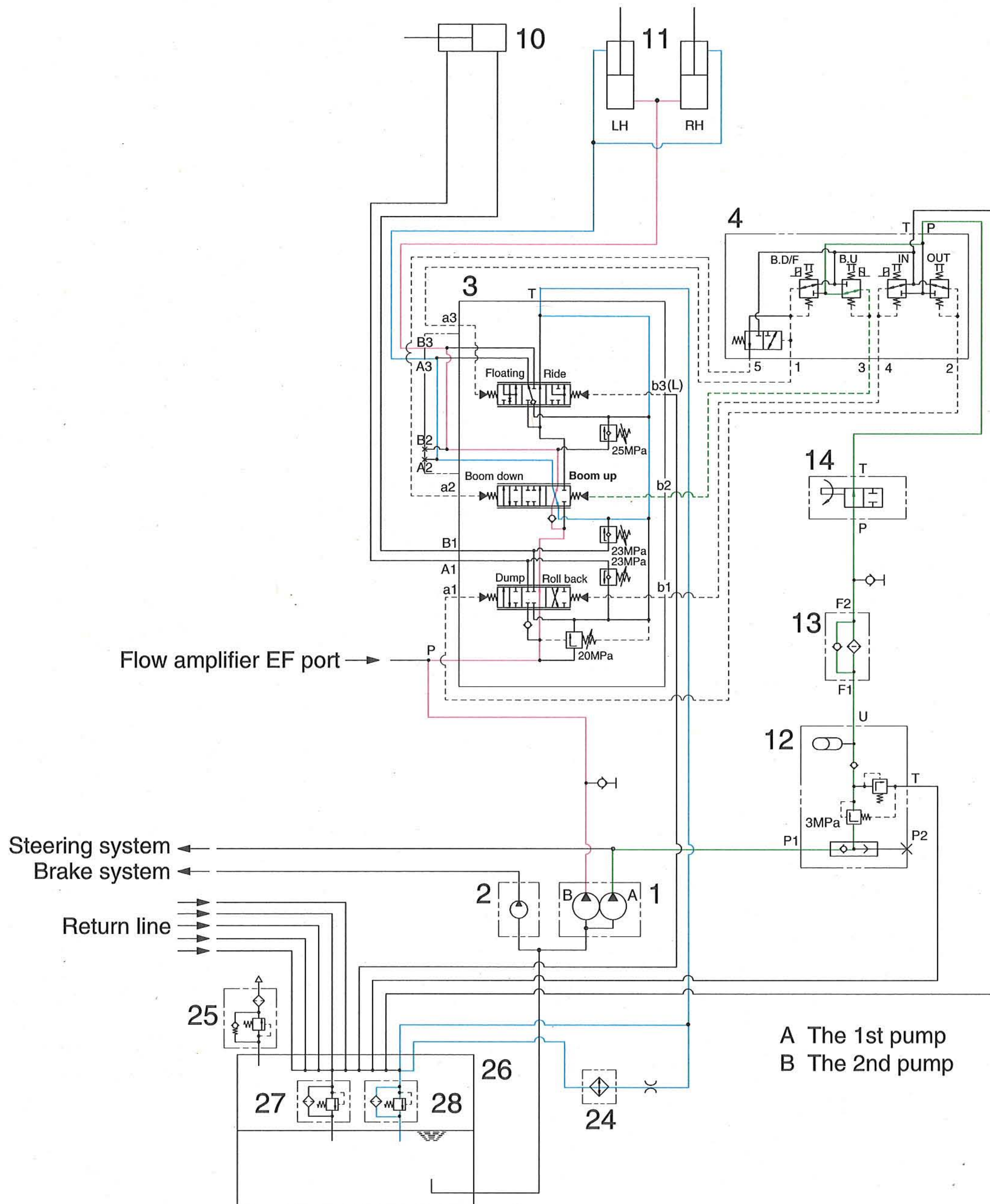

- When the RCV lever(4) is pulled back, the boom spool on the second block is moved to raise position by pilot oil pressure from port 3 of RCV.
- The oil from main pump(1) flows into main control valve(3) and then goes to the large chamber of boom cylinder(11) by pushing the load check valve of the boom spool through center bypass circuit of the bucket spool.
- The oil from the small chamber of boom cylinder(11) returns to hydraulic oil tank(26) through the boom spool at the same time.
- When this happens, the boom goes up.



## 2) WHEN THE RCV LEVER IS IN THE LOWER POSITION

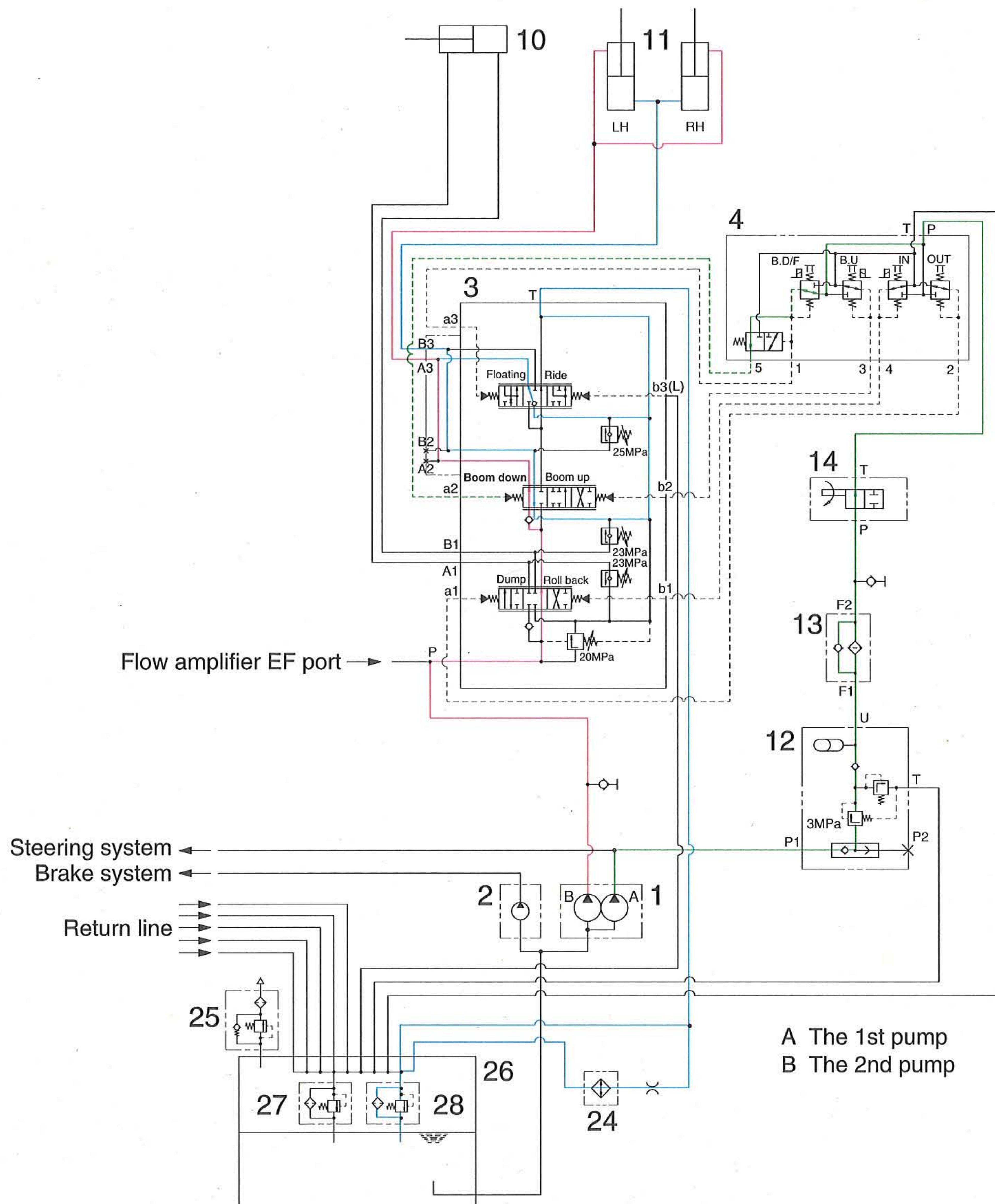

- When the RCV lever(4) is pushed forward, the boom spool on the second block is moved to lower position by pilot pressure from port 5 of RCV.
  - The oil from main pump(1) flows into main control valve and then goes to small chamber of boom cylinder(11) by pushing the load check valve of the boom spool through center bypass circuit of the bucket spool.
  - The oil returned from large chamber of boom cylinder(11) returns to hydraulic tank(26) through the boom spool at the same time.
  - When the lowering speed of boom is faster, the return oil from the large chamber of boom cylinder combines with the oil from the pump through the boom float spool on the third block, and flows into the small chamber of the cylinder.
- This prevents cylinder cavitation by the negative pressure when the pump flow cannot match the boom down speed.



### 3) WHEN THE RCV LEVER IS IN THE FLOAT POSITION

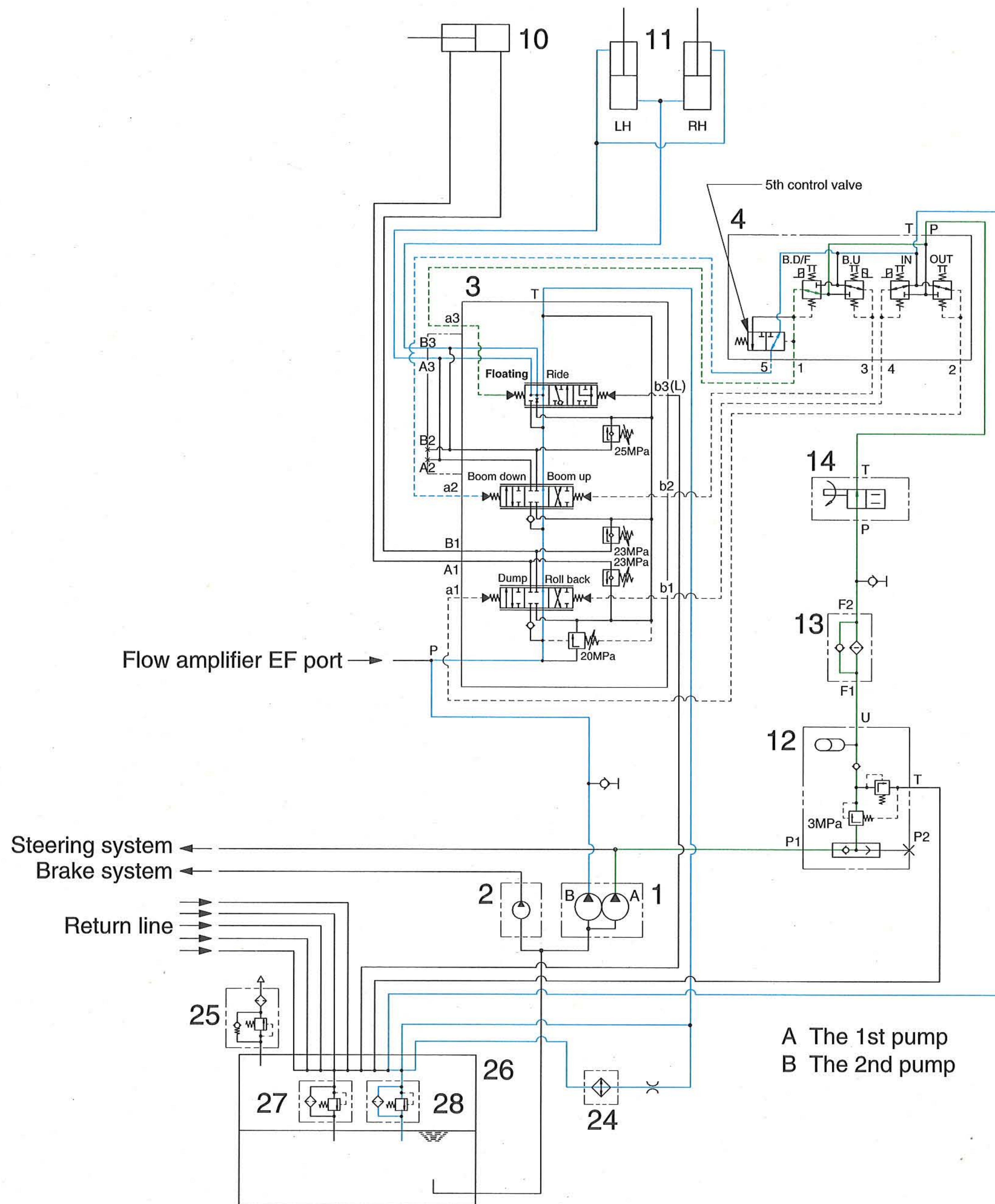

- When the RCV lever(4) is pushed further forward from the lower position, the boom down pilot port(5) is connected with tank port(T) by shift of 5th control valve. Thus, the boom spool is return to neutral position and the boom float spool is moved to float position by pilot oil pressure from port 1 of RCV.
- The work ports(A3), (B3) and the small chamber and the large chamber are connected to the return passage, so the boom will be lowered due to it's own weight.
- In this condition, when the bucket is in contact with the ground, it can be move up and down in accordance with the shape of the ground.



#### 4) WHEN THE RCV LEVER IS IN THE DUMP POSITION

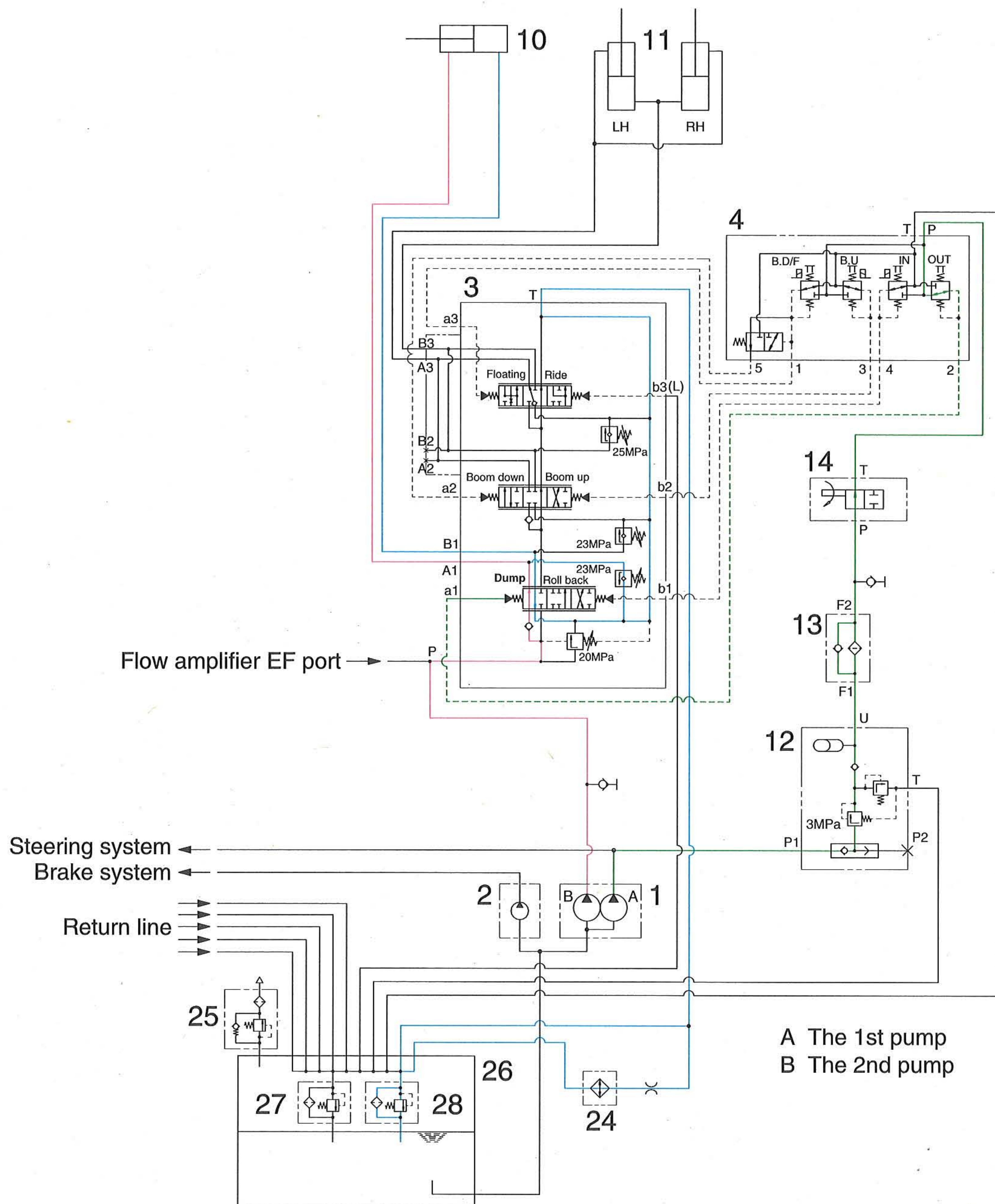

- If the RCV lever(4) is pushed right, the bucket spool on the first block is moved to dump position by pilot oil pressure from port 2 of RCV.
- The oil from main pump(1) flows into main control valve(3) and then goes to the small chamber of bucket cylinder(10) by pushing the load check valve of the bucket spool.
- The oil at the large chamber of bucket cylinder(10) returns to hydraulic tank(26) through the bucket spool.
- When this happens, the bucket is dumped.
- When the dumping speed of bucket is faster, the oil returned from the large chamber of bucket cylinder combines with the oil from the pump, and flows into the small chamber of the cylinder. This prevents cylinder cavitation by the negative pressure when the pump flow cannot match the bucket dump speed.



5) WHEN THE RCV LEVER IS IN THE ROLL BACK(RETRACT) POSITION

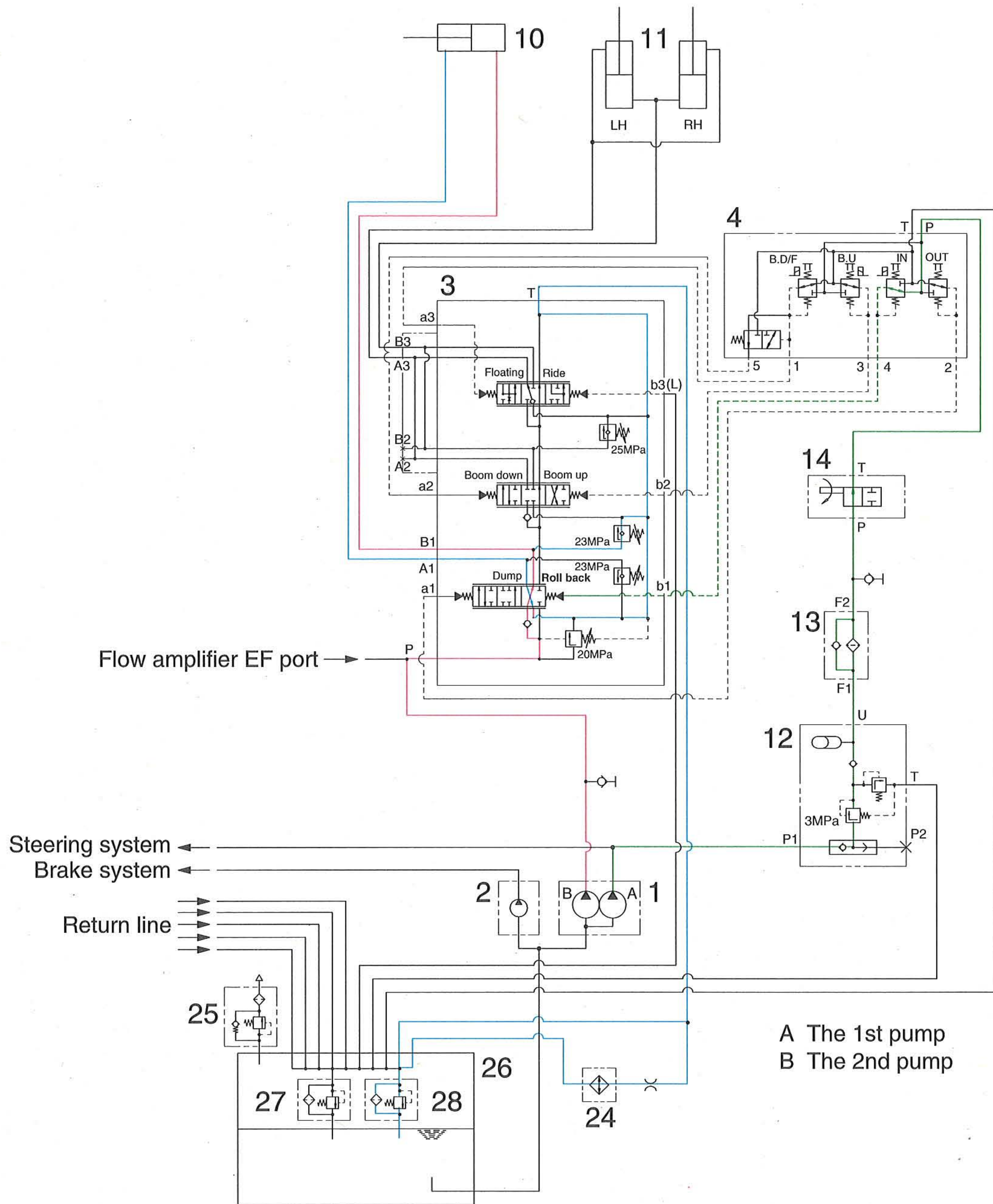

- If the RCV lever(4) is pulled left, the bucket spool on the first block is moved to roll back position by pilot oil pressure from port 4 of RCV.
- The oil from main pump(1) flows into main control valve(3) and then goes to the large chamber of bucket cylinder by pushing the load check valve of the bucket spool.
- The oil at the chamber of bucket cylinder(10) returns to hydraulic tank(26) through the bucket spool.
- When this happens, the bucket roll back.
- When the rolling speed of bucket is faster, the return oil from the small chamber of bucket cylinder combines with the oil from the pump, and flows into the large chamber of the cylinder. This prevents cylinder cavitation by the negative pressure when the pump flow cannot match the bucket rolling speed.



6) WHEN THE RCV LEVER IS IN THE HOLD POSITION

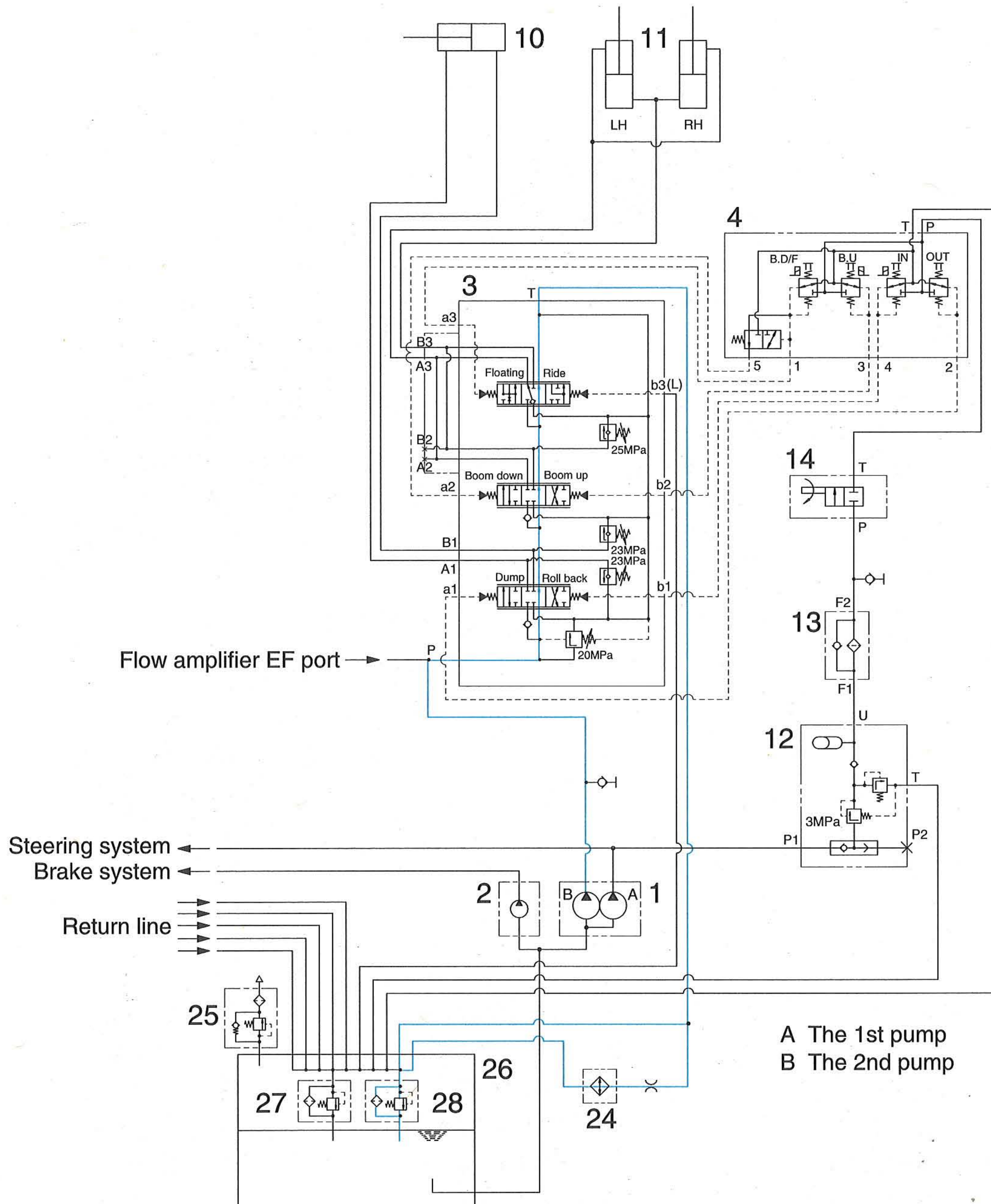

- The oil from main pump(1) flows into main control valve(3).
- In this time, the bucket spool, the boom spool and the boom float spool are in neutral position, then the oil supplied to main control valve(3) returns into hydraulic tank(26) through center bypass circuit of each spool.
- In this condition, each cylinder keeps the neutral position, so the boom and the bucket is holded.



### 3. MAIN PUMP OPERATION

#### 1) STRUCTURE

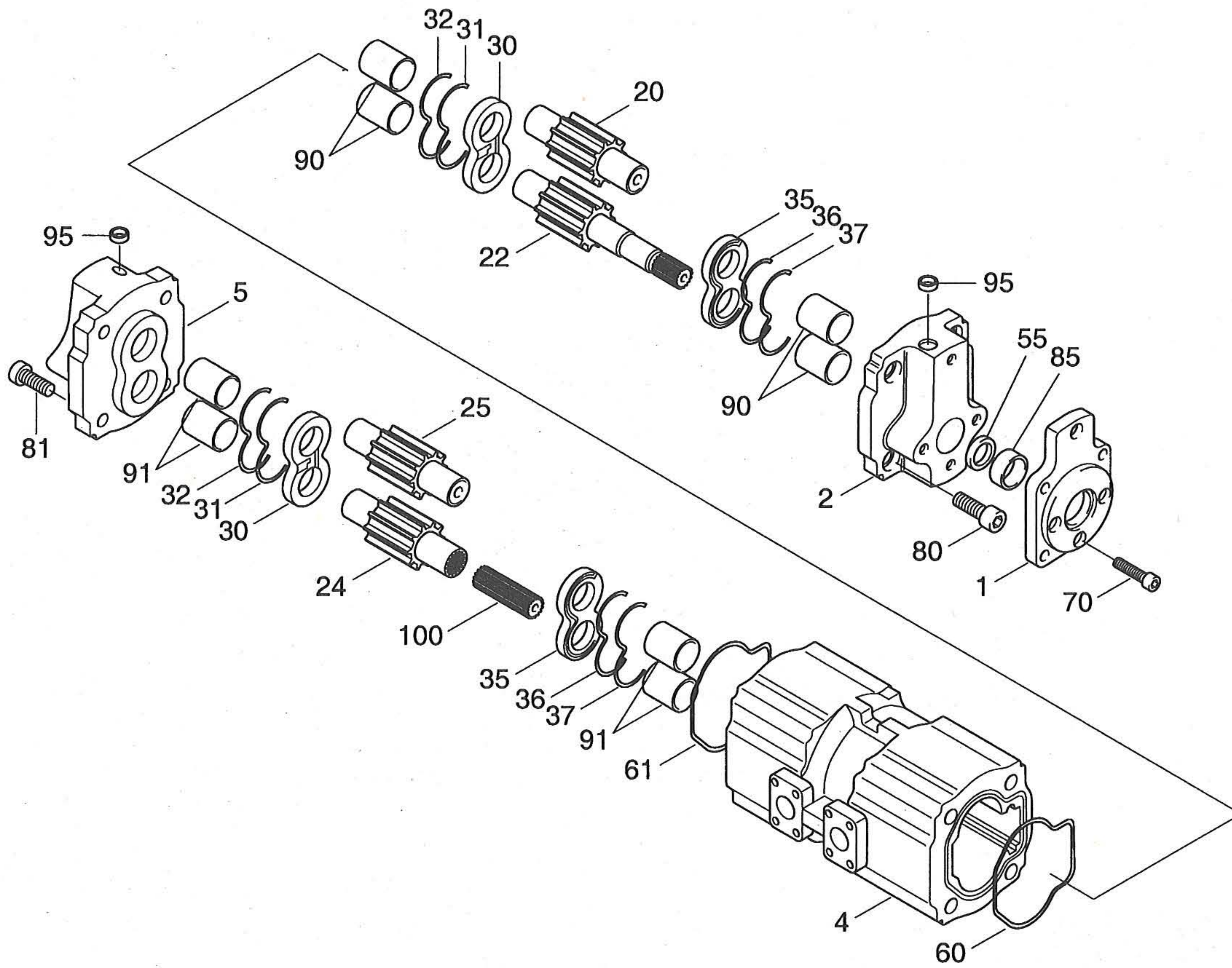

1	Flange	31	Moulded seal	80	Screw
2	Front cover	32	Back up seal	81	Screw
4	Dual body	35	Wear plate	85	Ring
5	Rear cover	36	Moulded seal	90	Bearing
20	Driven gear	37	Back up seal	91	Bearing
22	Front drive gear	55	Shaft seal	95	Seal
24	Rear drive gear	60	O-ring	100	Coupling
25	Driven gear	61	O-ring		
30	Wear plate	70	Screw		



## 2) OPERATION

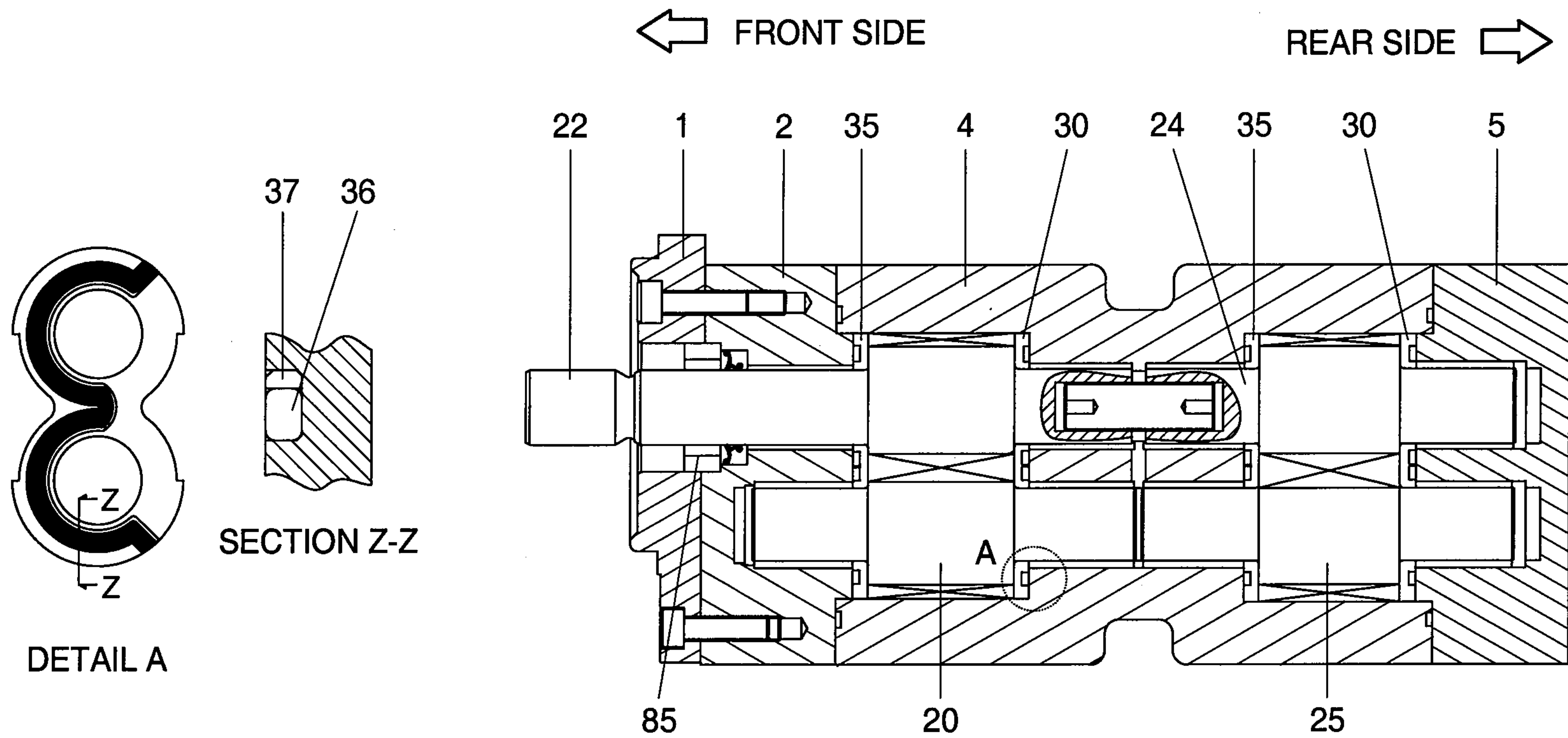

The main hydraulic pump is a fixed displacement gear type pump. The pump is drive at engine speed by the transmission. The pump shafts are supported by location ring(85) in the flange(1), front cover(2), dual body(4) and rear cover(5). The wear plates(30, 35) are located between the gear surface and covers(2, 5) and dual body(4).

As the drive gear(22) and (24) turns the idler gear(20) and (25), the gear teeth come out of mesh. Oil flows from the hydraulic tank through the inlet the cavity between the gear teeth. As the gears continue to rotate, the oil becomes trapped between the gear teeth and the dual body(4). The trapped oil is then carried to the pump outlet. Oil is forced out the outlet to supply the hydraulic function. As the gears re-mesh, they form a seal to prevent oil from flowing between the gears and back to the inlet.

The pump uses outlet pressure oil to load the wear plates(30, 35) against the gear faces. This controls internal leakage to maintain pump displacement.

Outlet pressure fills the area bounded by the pressure balance moulded seals(31, 36) to force the wear plate against the high pressure area or the gear faces. Pump shaft lubrication is achieved by routing outlet pressure oil into the area between the gear shafts and the bearings. The oil is collected at the end of the shafts in the hollow areas in the port and flange plates and routed back to return.



## 4. REMOTE CONTROL VALVE

### 1) STRUCTURE

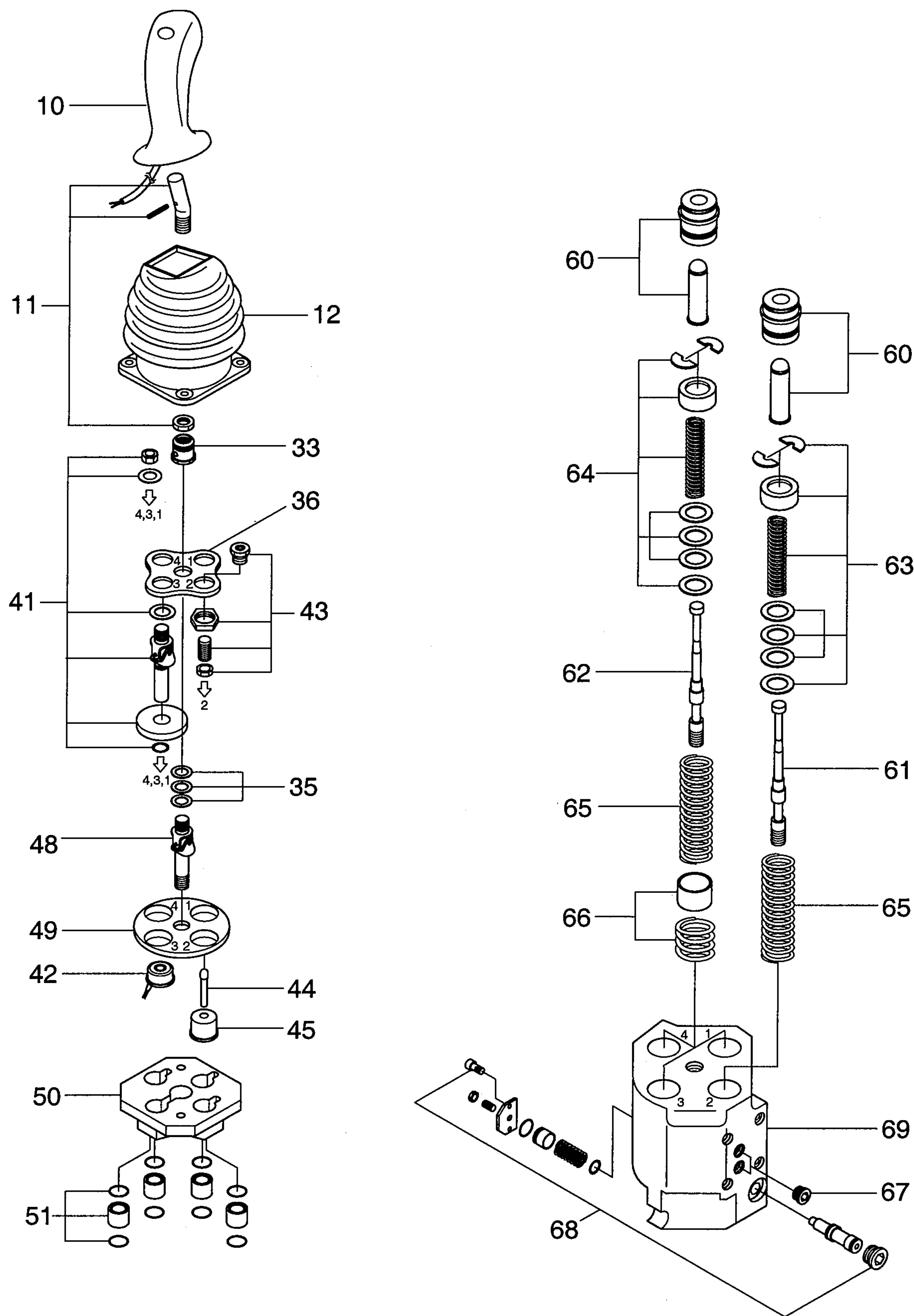

10	Handle	44	Intermediary plunger	63	Regulating sub assy
11	Lever kit	45	Plunger guide assy	64	Regulating sub assy
12	Bellows	48	Joint	65	Spring set
33	Nut	49	Flange	66	Freefeel point kit
35	Shim kit	50	Electric bracket	67	Plug kit
36	Bracket	51	Bushing kit	68	5th control port kit
41	Joint kit	60	Plunger kit	69	Body
42	Solenoid complete	61	Spool		
43	Plunger kit	62	Spool		



## 2) OPERATION

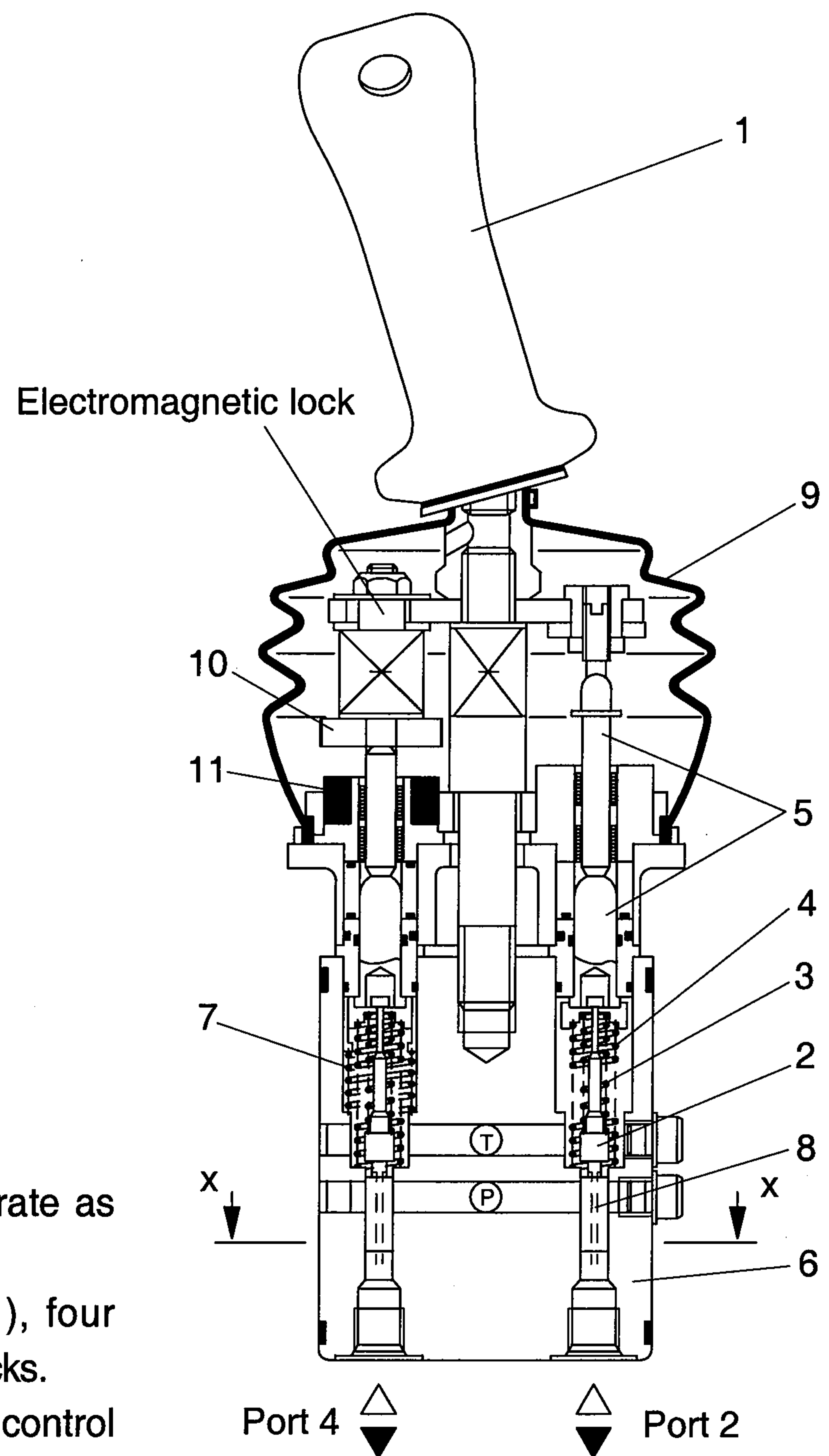
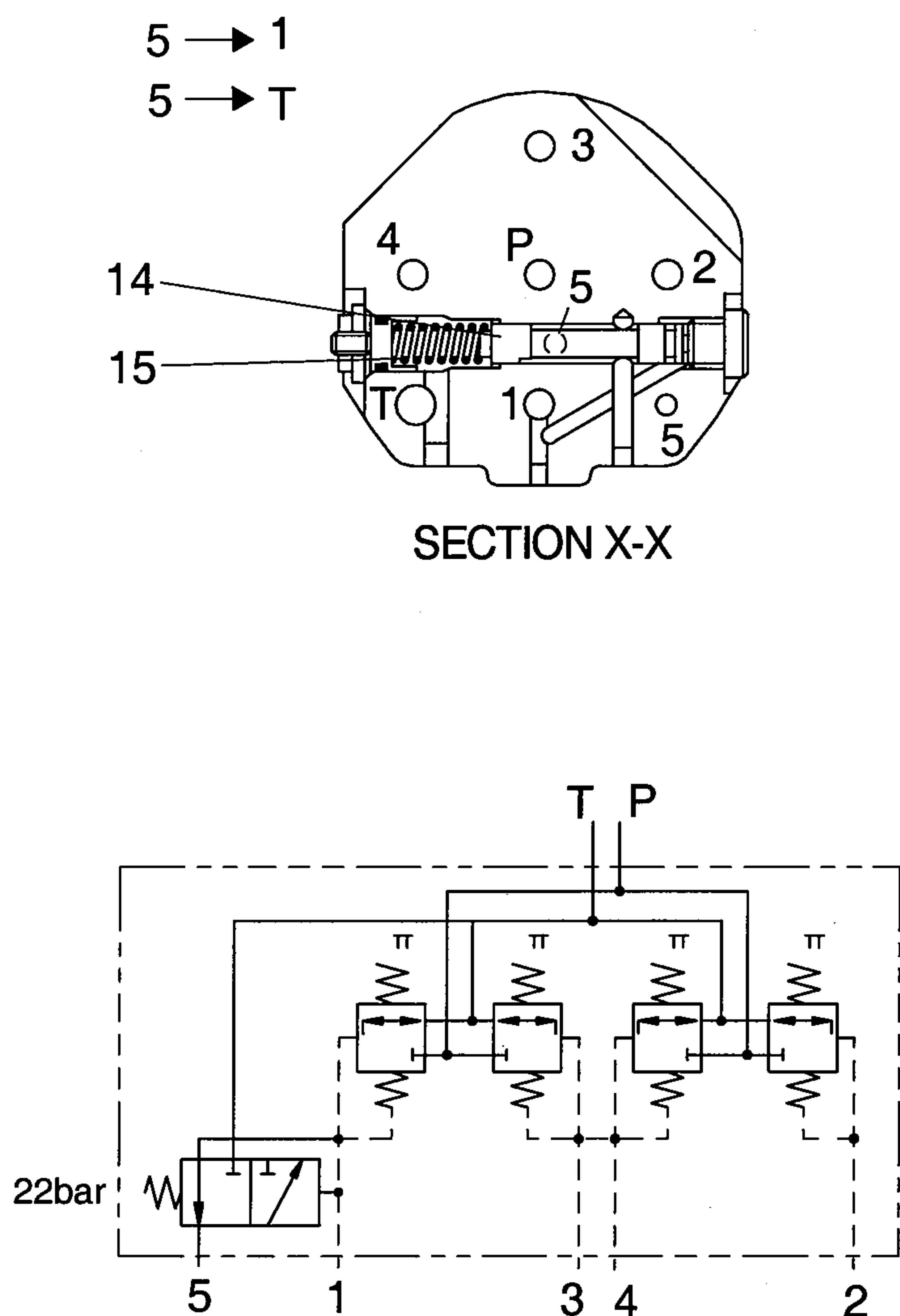

### (1) Hydraulic functional principle

Pilot devices with end position locks operate as direct operated pressure reducing valves.

They basically comprise control lever(1), four pressure reducing valves, housing(6) and locks.

Each pressure reducing valve comprises control spool(2), control spring(3), return spring(4) and push rod(5).

At rest control lever(1) is held in its neutral position by return springs(4). Ports(1, 2, 3, 4) are connected to tank port T via bore(8).

When control lever(1) is deflected push rod(5) is pressed against return spring(4) and control spring(3).

Control spring(3) initially moves control spool(2) downwards and closes the connection between the relevant port and tank port T. At the same time the relevant port is connected to port P via bore(8). The closed loop control phase starts, as soon as control spool(2) finds its balance between the force from control spring(3) and the force, which results from the hydraulic pressure in the relevant port(port 1, 2, 3 or 4).

Due to the interaction between control spool(2) and control spring(3) the pressure in the relevant port is proportional to the stroke of push rod(5) and hence to the position of control lever(1).

This closed loop pressure control dependent on the position of the control lever and the characteristics of the control spring permits the proportional hydraulic control of the main directional valve.

Rubber sleeve(9) protects the mechanical components in the housing from contamination.



**(2) End position lock**

Only those control ports, for which it is necessary to hold the control lever in a deflected position are equipped with end position locks.

**Electromagnetic lock**

An additional spring(7) under push rod(5) warns, due to the increase in force which is required to keep this spring compressed, that the stroke of push rod(5) and control lever(1) is nearly at its end.

Once this point has been exceeded ring(10) is placed in contact with solenoid armature(11).

If the solenoid is energized, control lever(1) is held in its end position by means of the electromagnetic force.

The lock is released automatically when the solenoid is deenergized.

**(3) Fifth control port**

This remote control valve is equipped with a fifth control port, which is used to control the boom floating function. This function may be operated by moving spool(14) against spring(15) under the influence of the pressure acting in port 1.

As soon as this pressure reaches 22bar, control port 5 is connected with T.



# 5. MAIN CONTROL VALVE

## 1) STRUCTURE

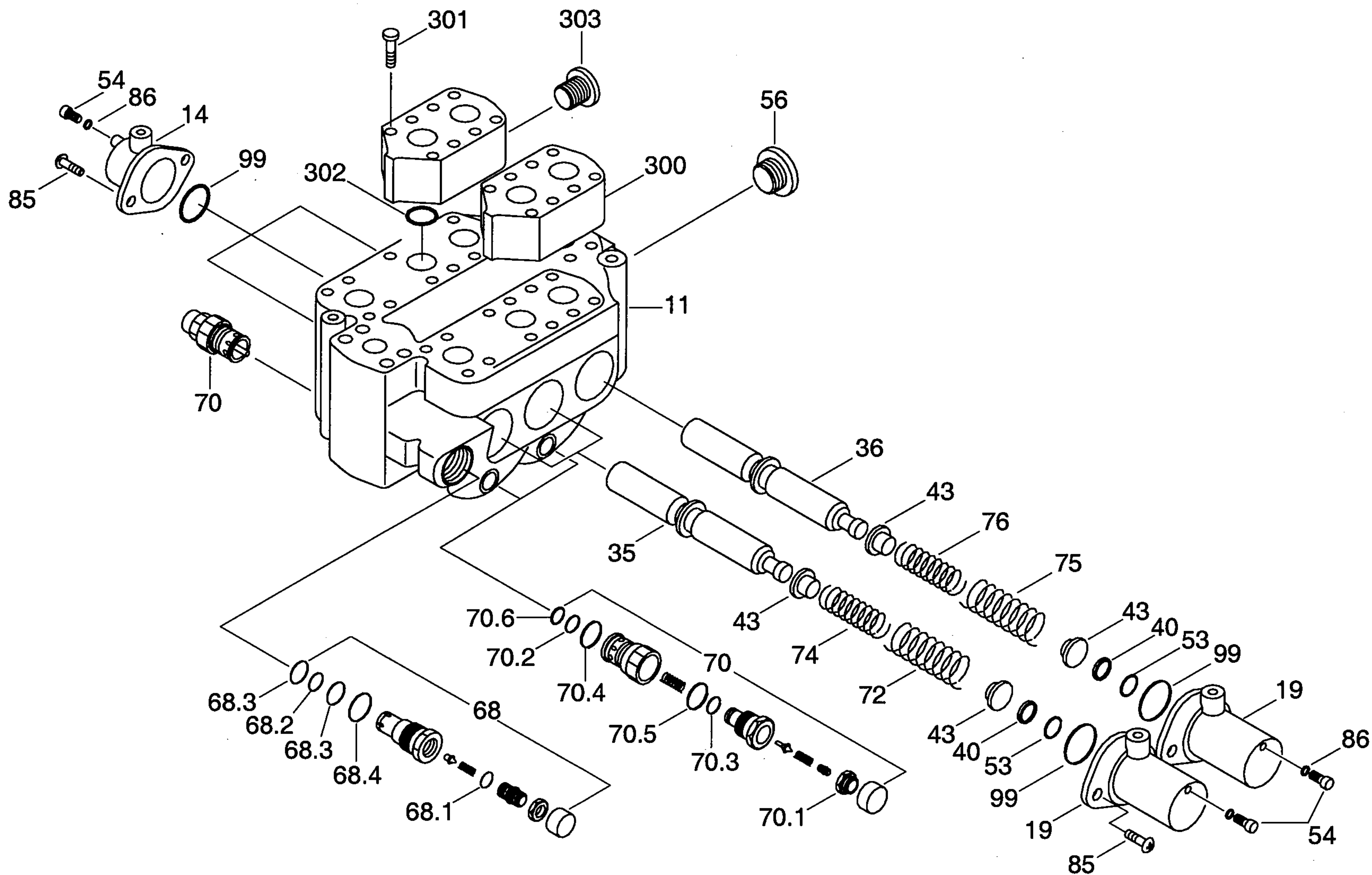

11	Housing	68.1	O-ring	72	Spring
14	Short cover	68.2	O-ring	74	Spring
19	Long cover	68.3	Thrust ring	75	Spring
35	Spool	68.4	O-ring	76	Spring
36	Spool	70	Overload relief valve	85	Screw
40	Ring	70.1	Seal	86	Seal ring
43	Spring retainer	70.2	O-ring	99	O-ring
53	Snap ring	70.3	Piston seal	300	Plate
54	Bleed screw	70.4	O-ring	301	Bolt
56	Locking screw	70.5	O-ring	302	O-ring
68	Main relief valve	70.6	Thrust ring	303	Locking screw



# STRUCTURE

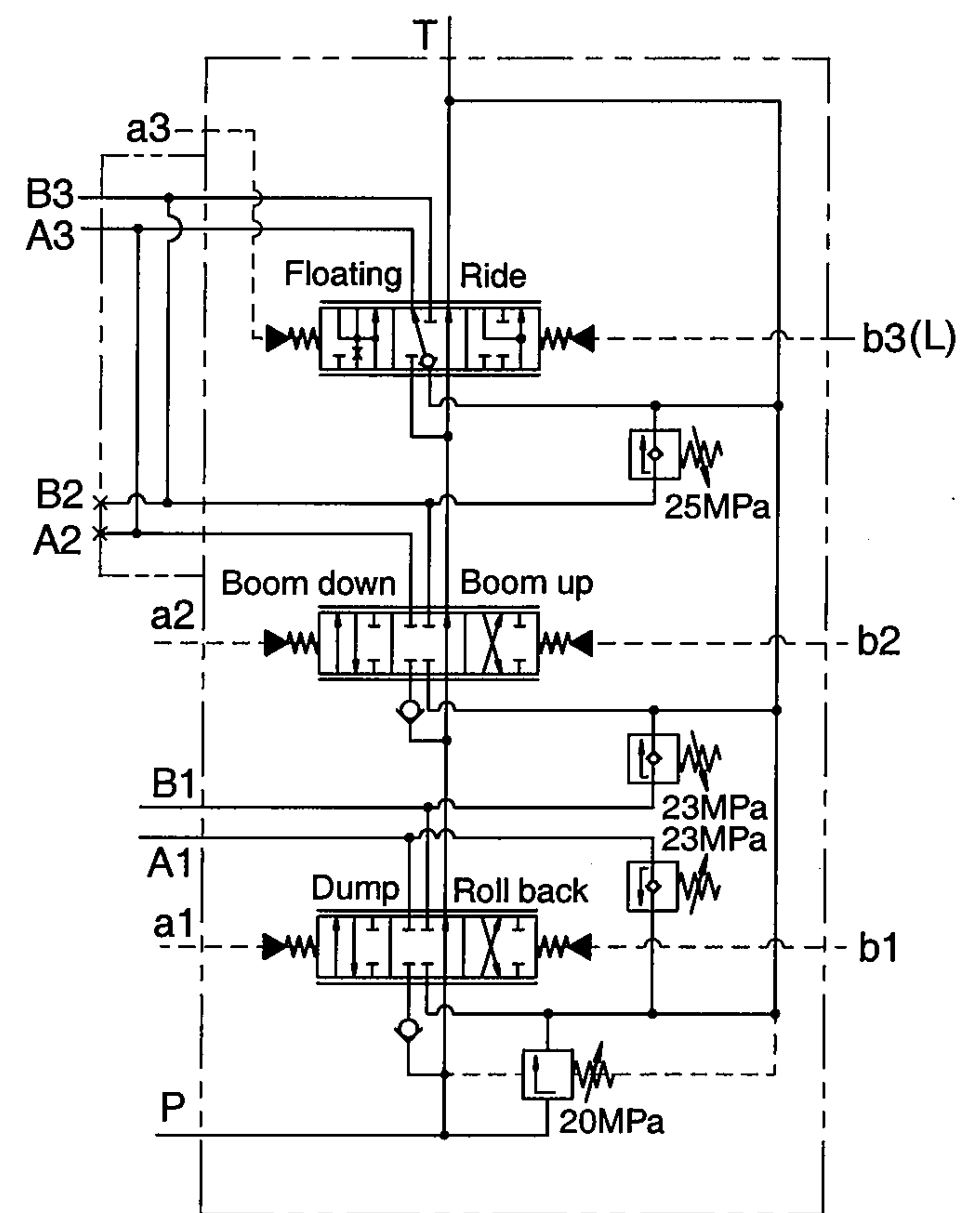
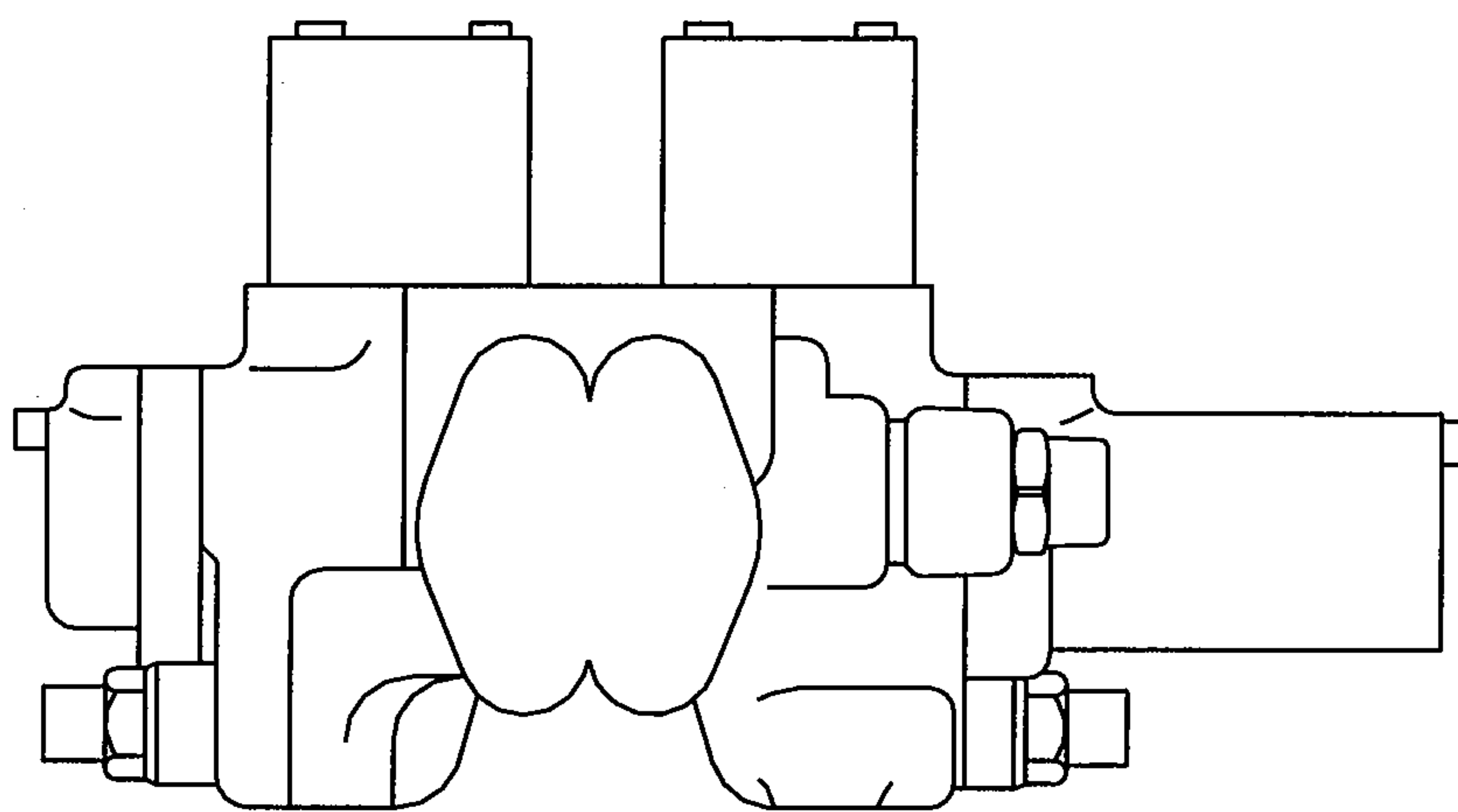
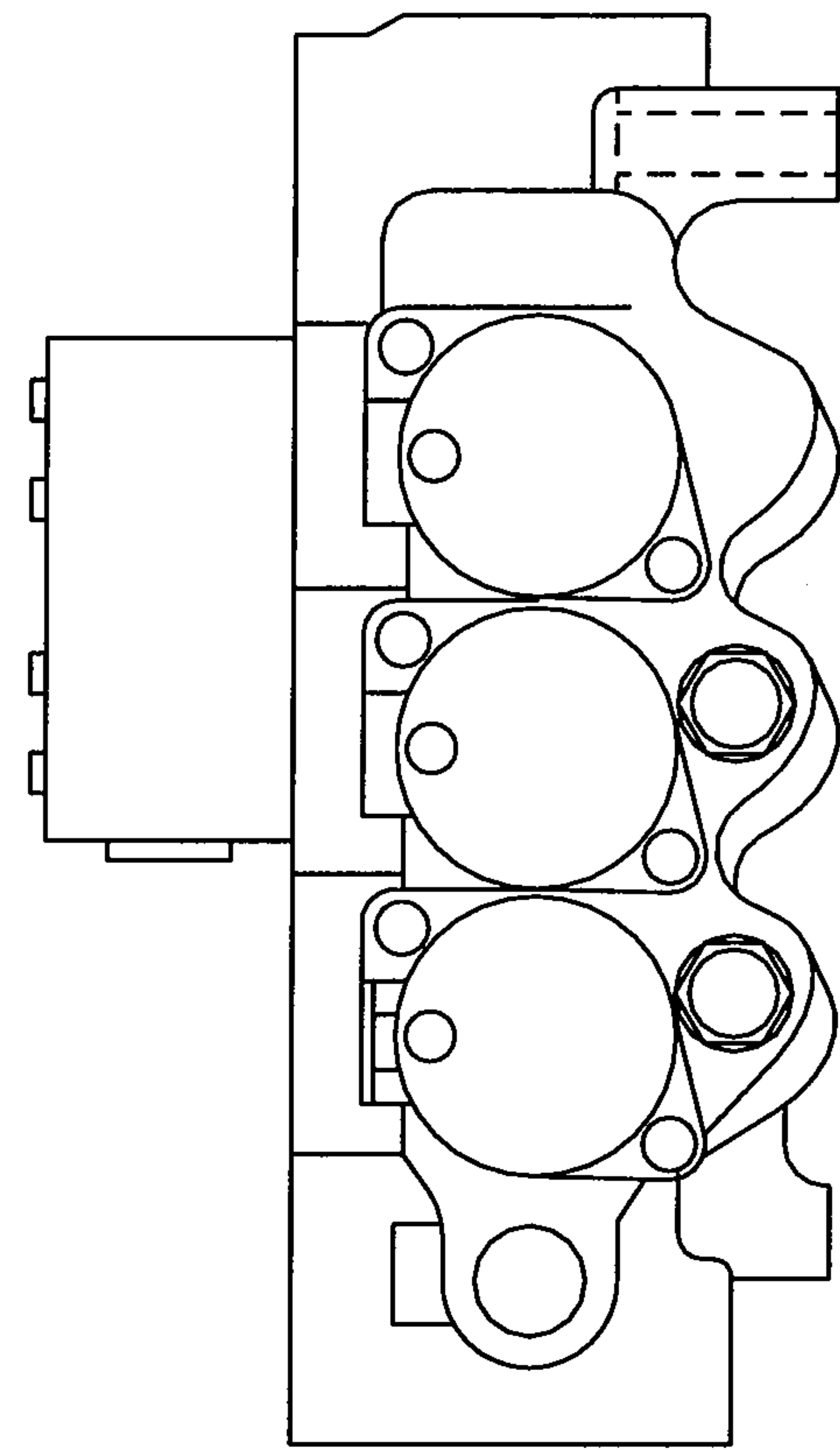
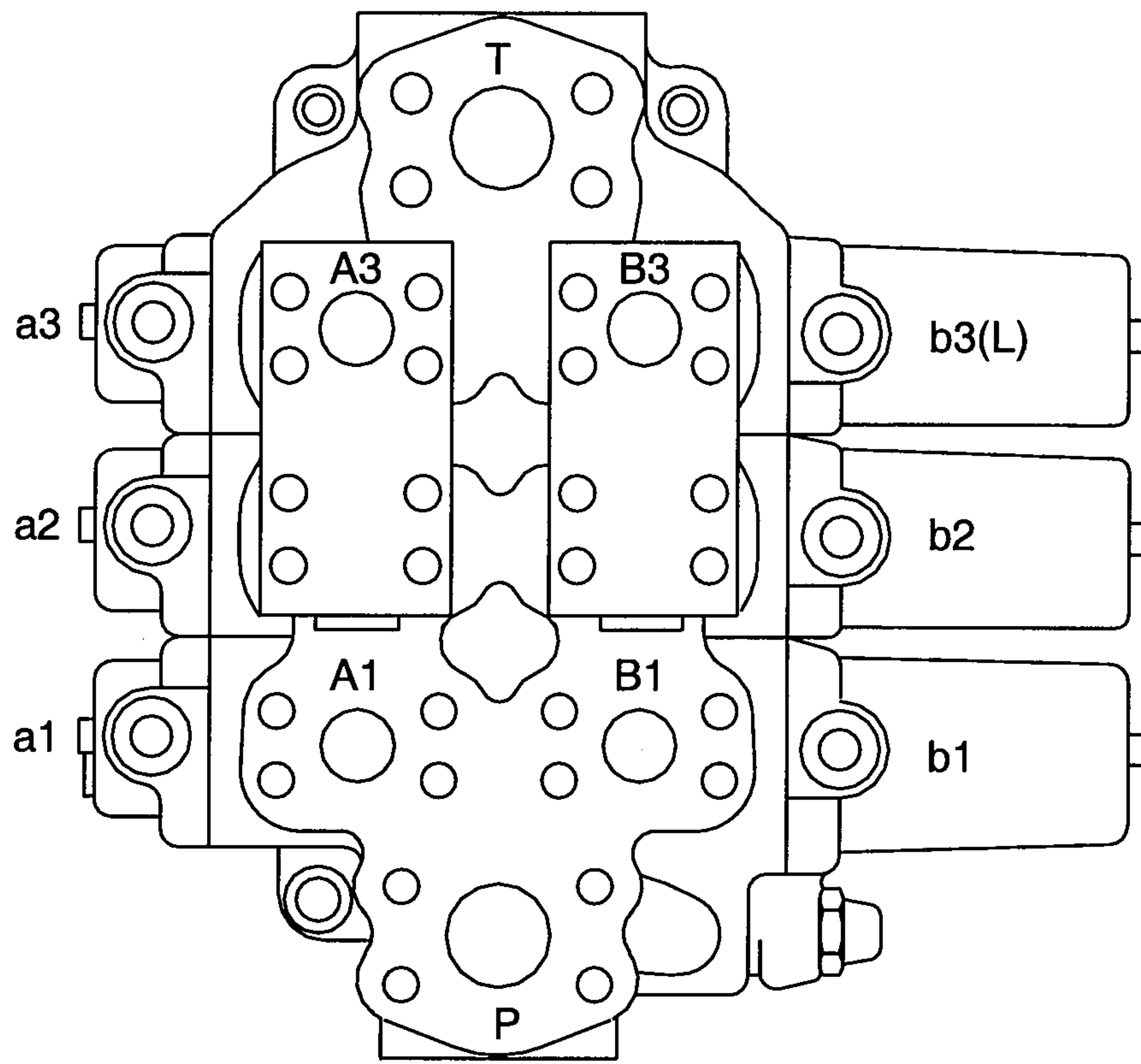

Port	Port name	Port size
P	From main pump	SAE 6000psi 1 1/2"
T	To hydraulic tank	SAE 6000psi 1 1/2"
A1, B1	To bucket cylinder port	SAE 6000psi 1 1/4"
A3, B3	To boom cylinder port	SAE 6000psi 1 1/4"
a1, b1	Bucket pilot port	PF 1/4
a2, a3, b2, b3	Boom pilot port	PF 1/4



## 2) BOOM SECTION OPERATION

### (1) Spool in neutral

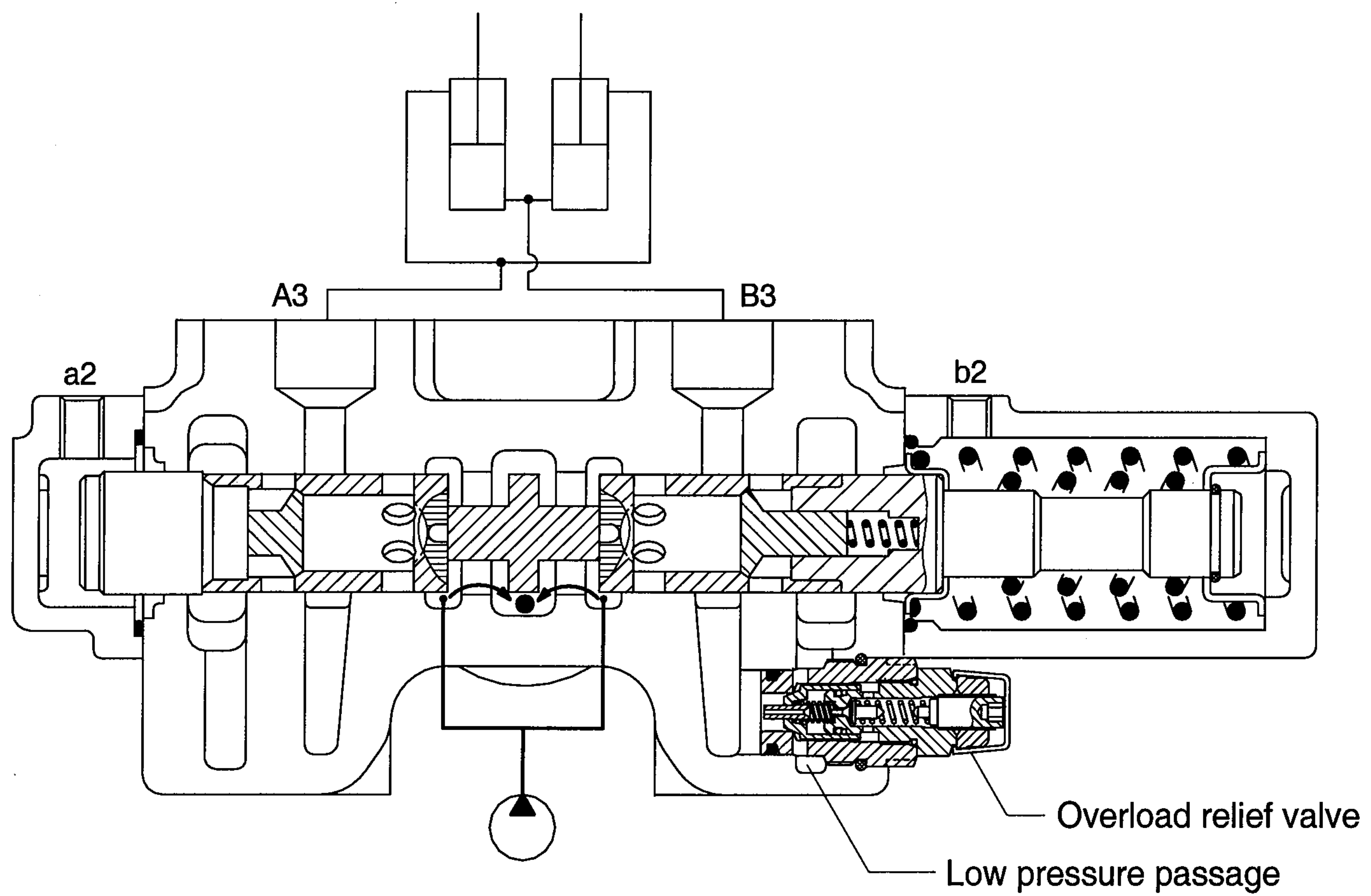
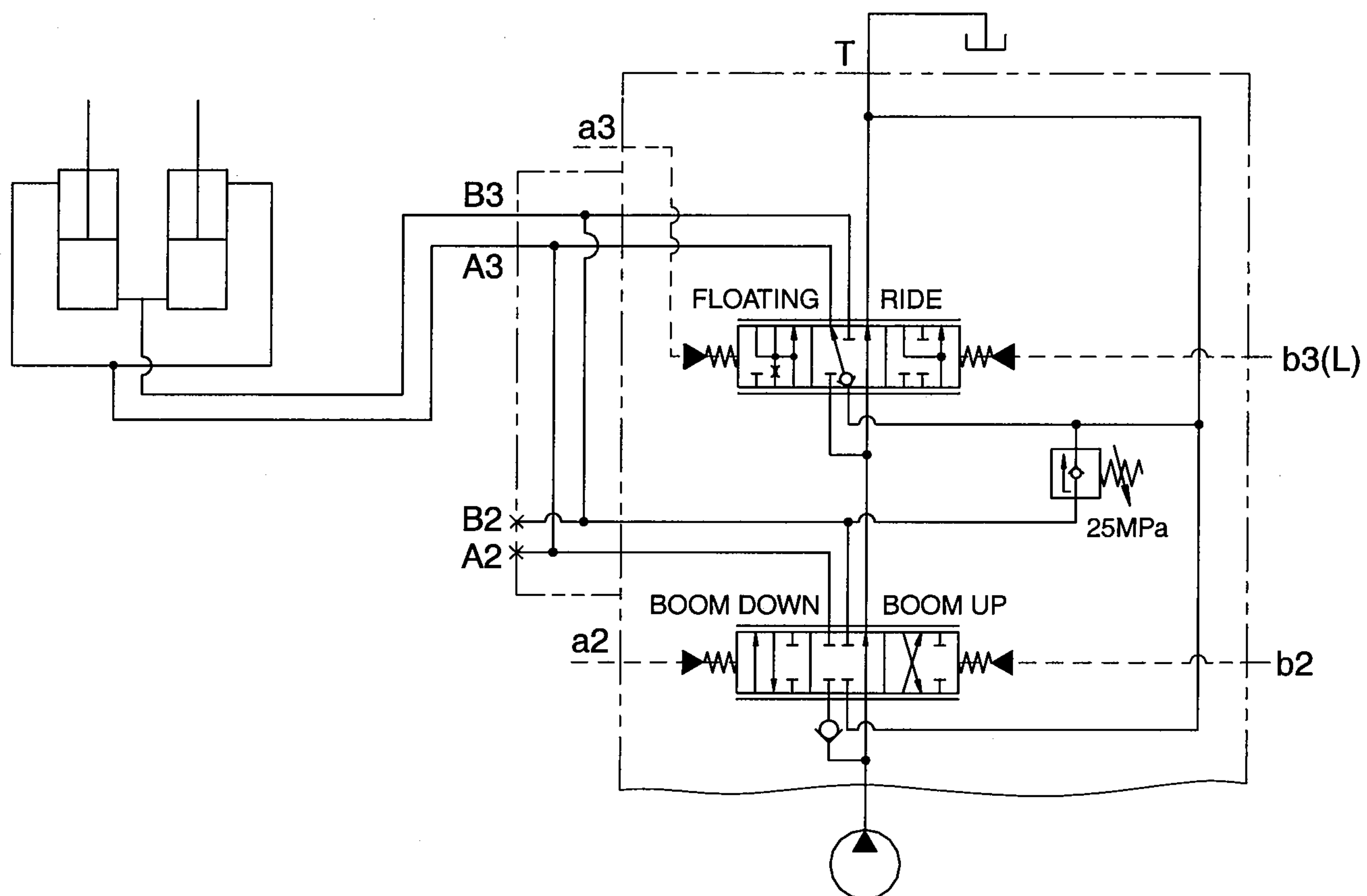

If the remote control valve is not operated, the oil supplied from the pump port passes through the neutral passage to the low pressure passage at the outlet section, and then returns to the tank port.



**(2) Boom raise position**

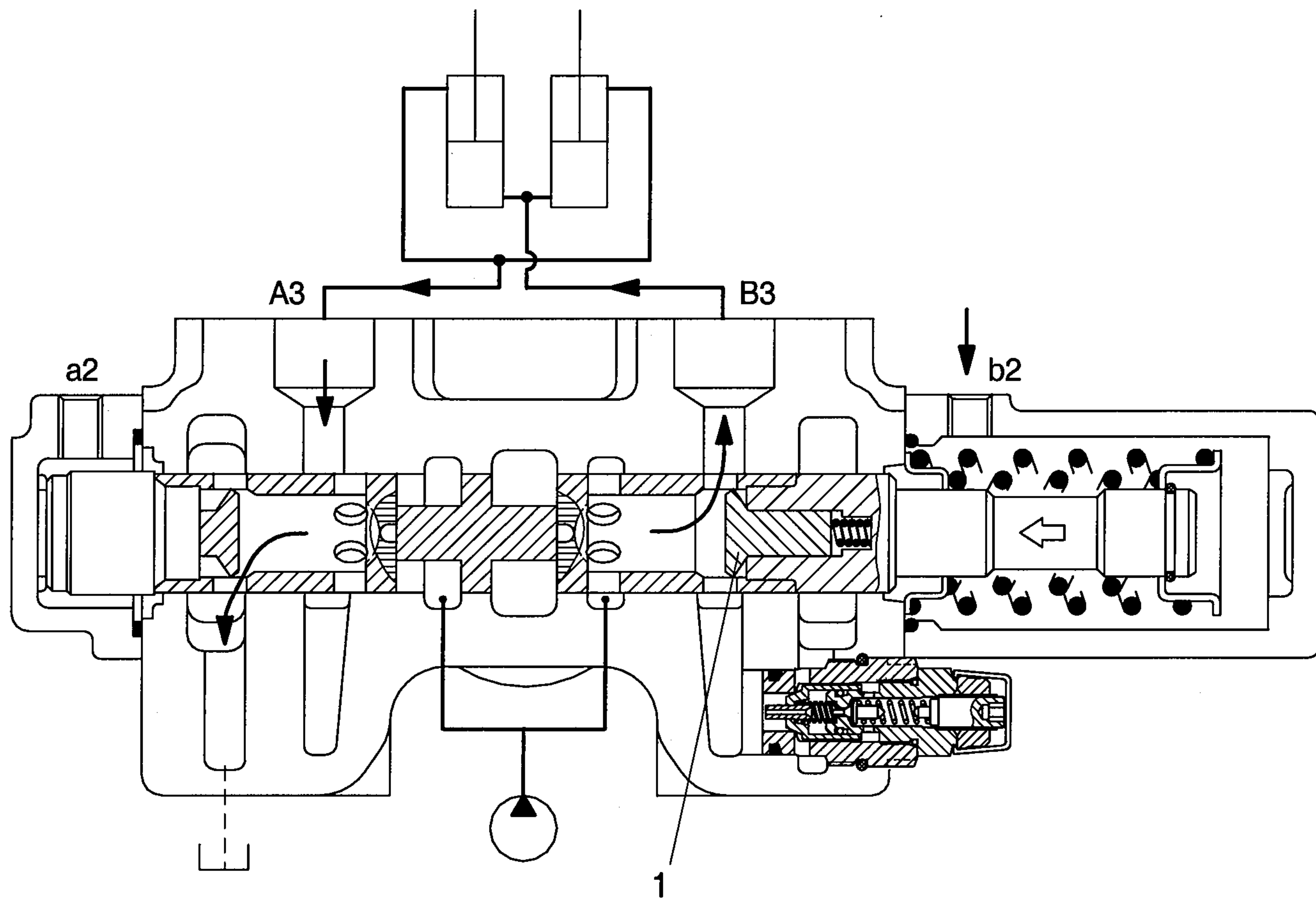
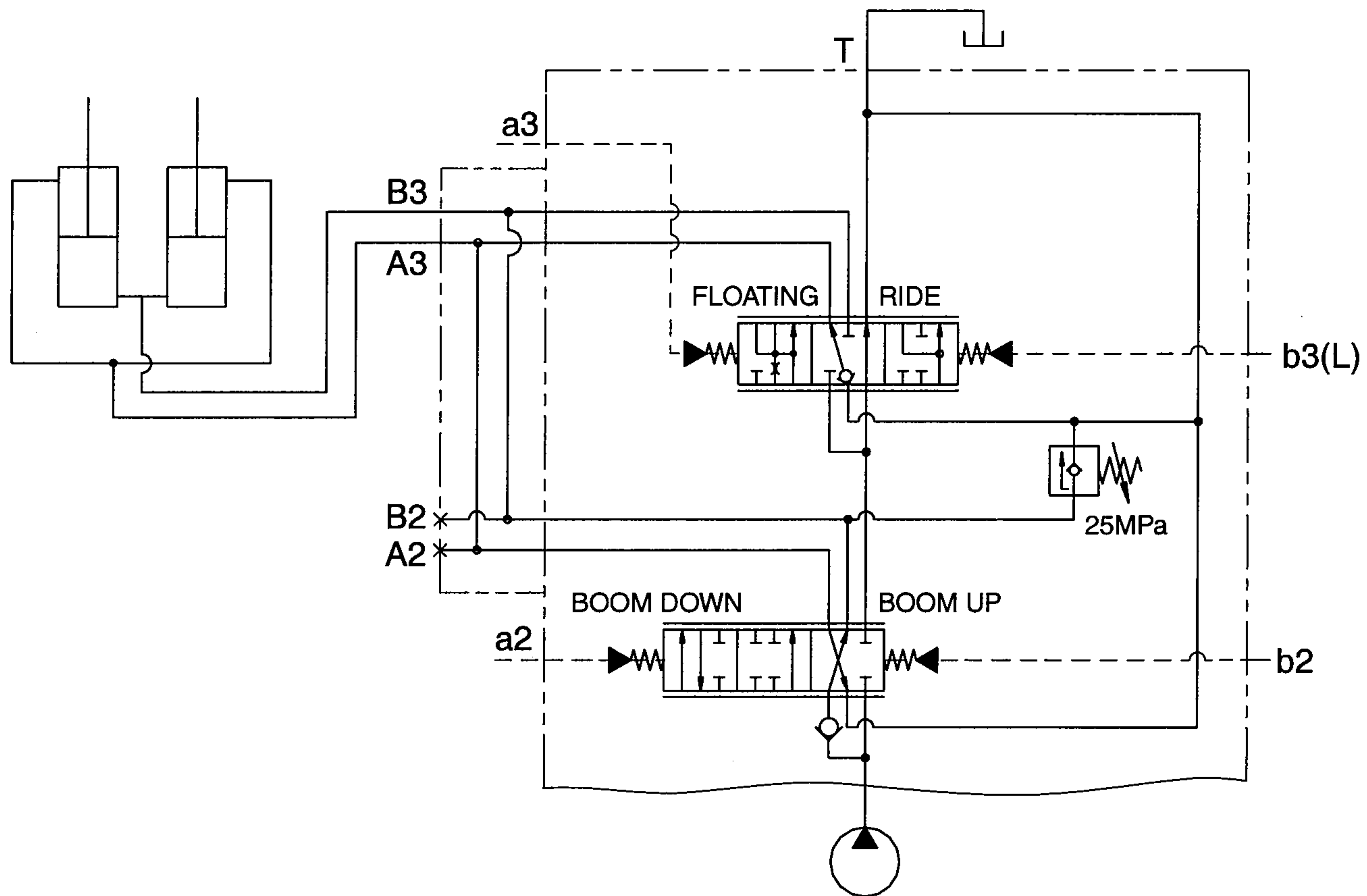

When the pilot pressure from remote control valve is supplied to the pilot port(b2), the spool moves to the left and the neutral passage is closed.

The oil supplied from the pump pushes up the load check valve(1) and flow into boom cylinder port(B3). The pump pressure reaches proportionally the load of cylinder and fine control finished by shut off of the neutral passage.

The return oil from cylinder port(A3) flows into the tank via the low pressure passage.



**(3) Boom lower position**

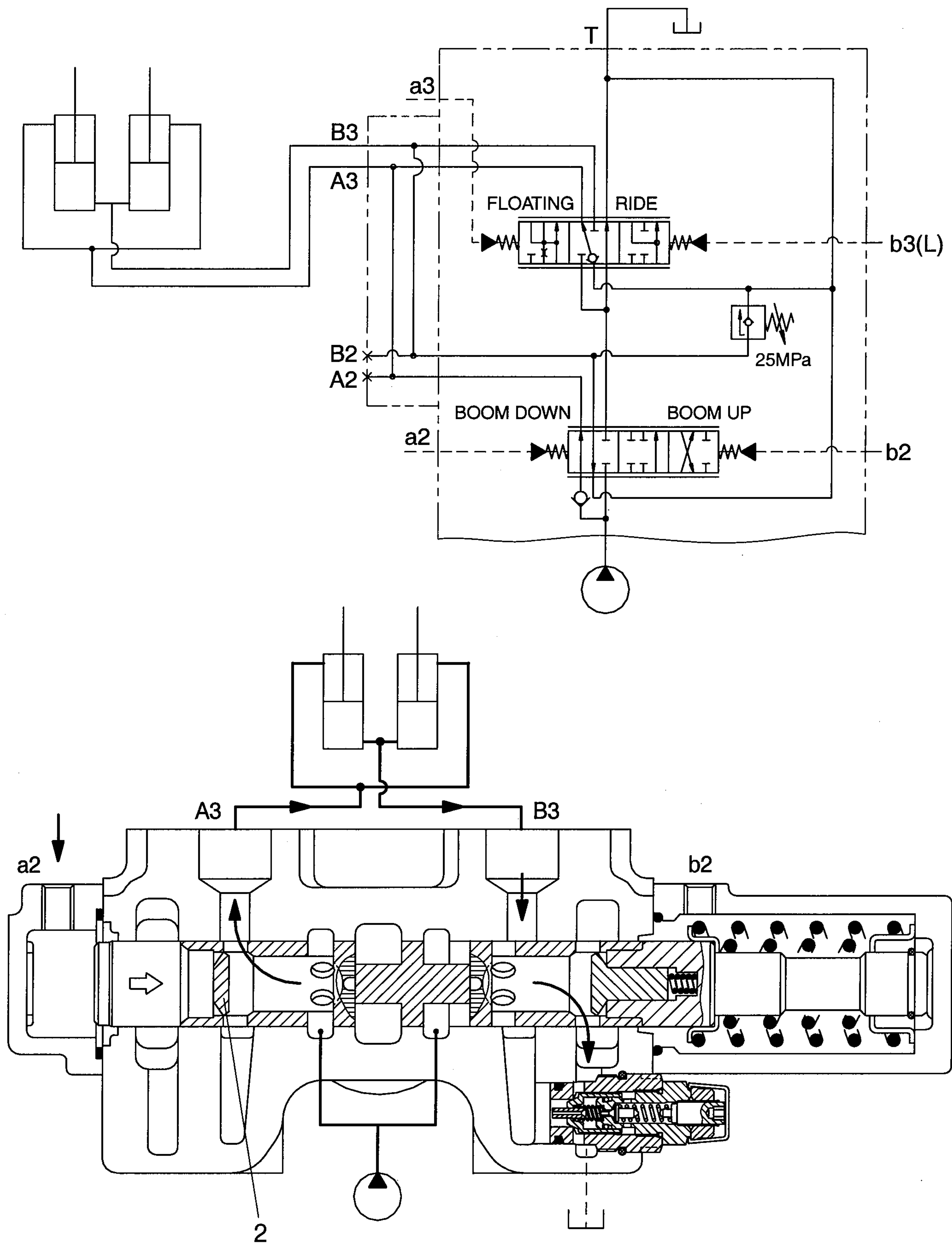

When the pilot pressure from remote control valve is supplied to the pilot port(a2), the spool moves to the right and the neutral passage is closed.

The oil supplied from the pump pushes up the load check valve(2) and flow into boom cylinder port(A3). The pump pressure reaches proportionally the load of cylinder and fine control finished by shut off of the neutral passage.

The return oil from cylinder port(B3) flows into the tank via the low pressure passage.



#### (4) Boom float position

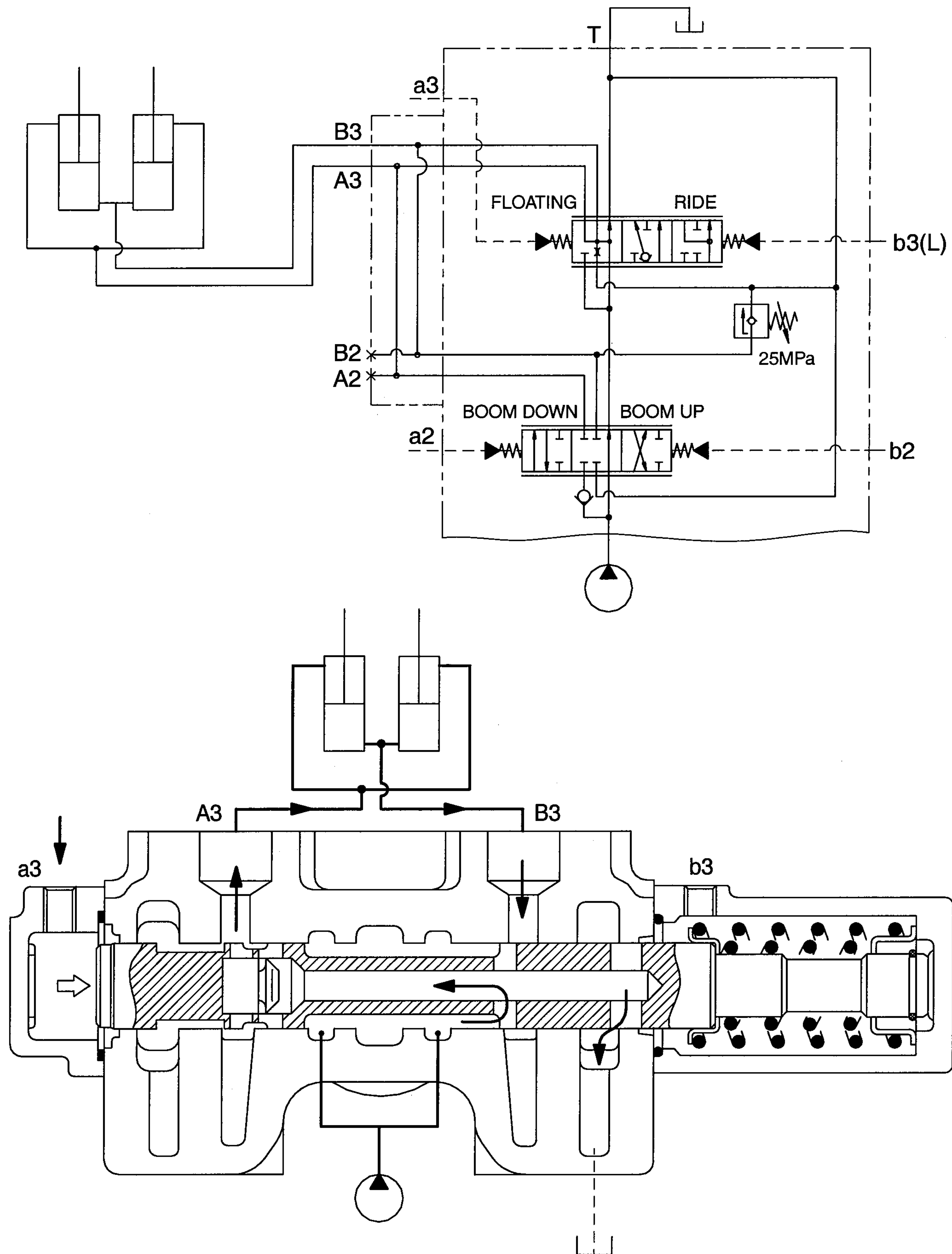

If the operator overrides the additional spring(7) in the RCV lower position, the pilot pressure from remote control valve rises further and then the boom float spool is pushed to the end position, opening up the neutral passage to tank and simultaneously(A3), (B3) → T.

Parallel the boom down spool will be released to neutral, because of moving spool in the remote control valve at 22bar(Refer to page 6-14).

In float position the boom drops quickly due to its own weight.

When the bucket touches the ground and the wheeled loader is moving, the bucket raised or lowered following the unevenness of the ground due to the (A3), (B3) → T connecting.



### 3) BUCKET SECTION OPERATION

#### (1) Spool in neutral

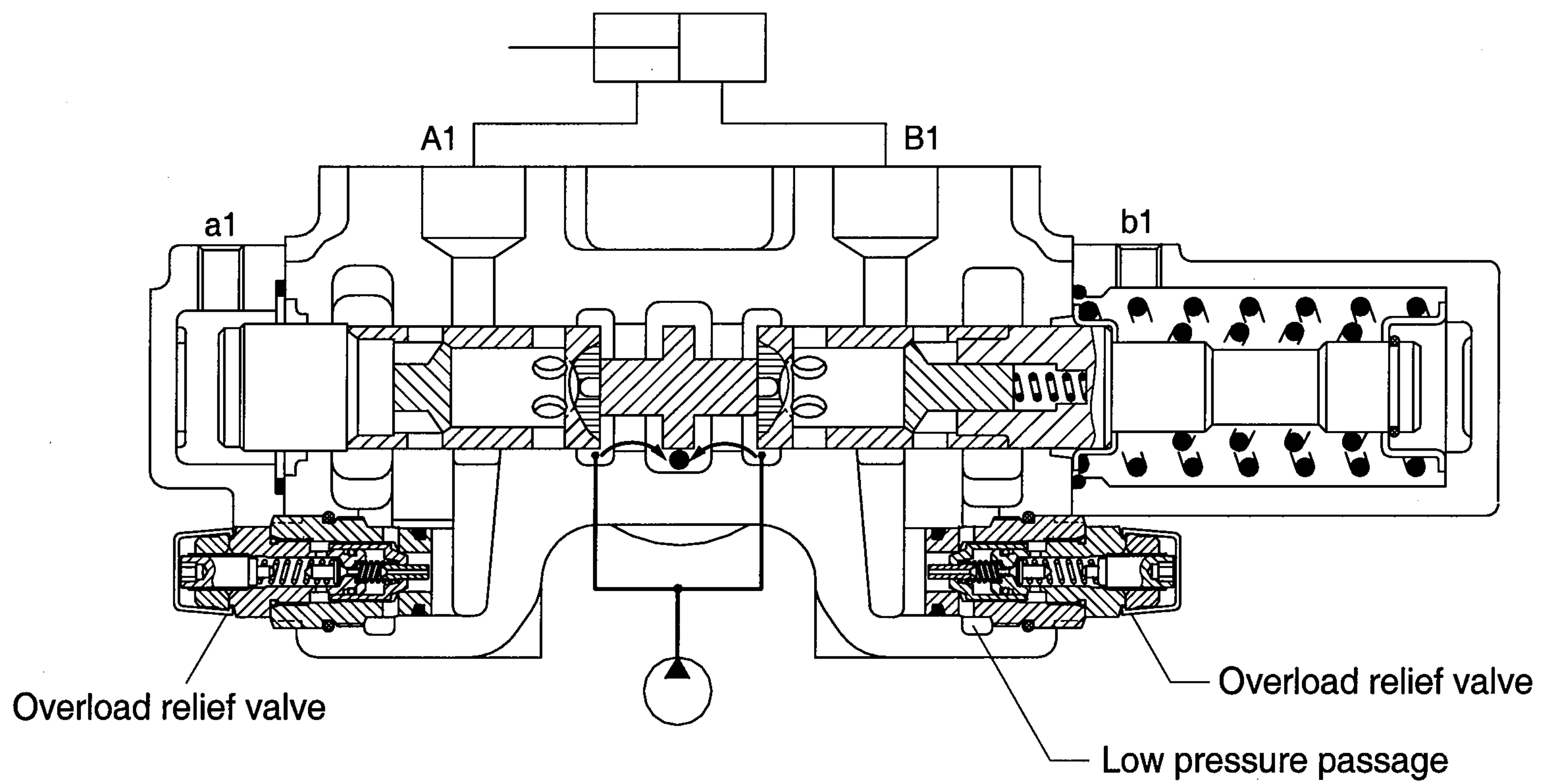
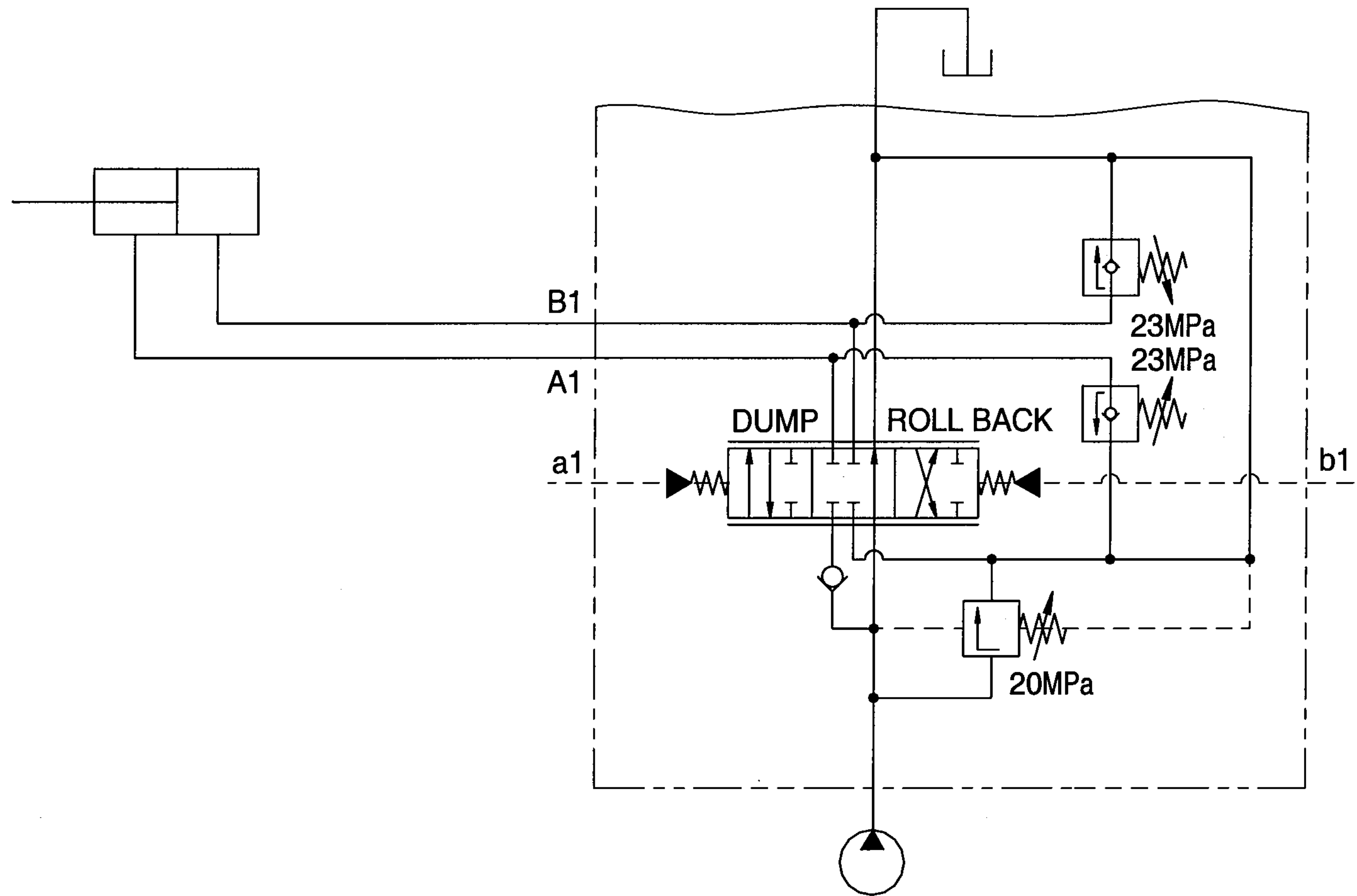

If the remote control valve is not operated, the oil supplied from the pump port passage through the neutral passage to the low pressure passage at the outlet section, and then return to the tank port.



**(2) Retract (Roll back) position**

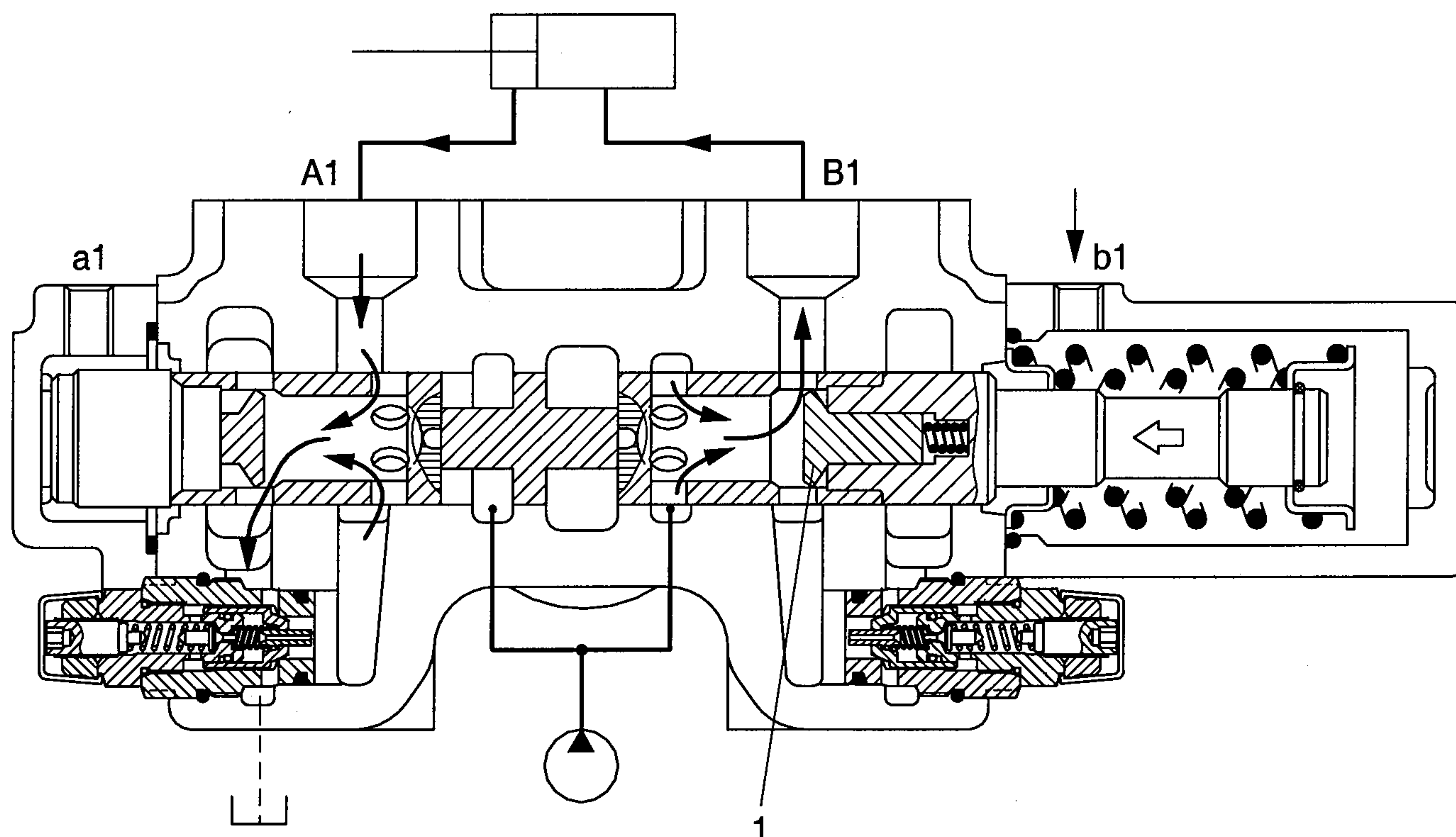
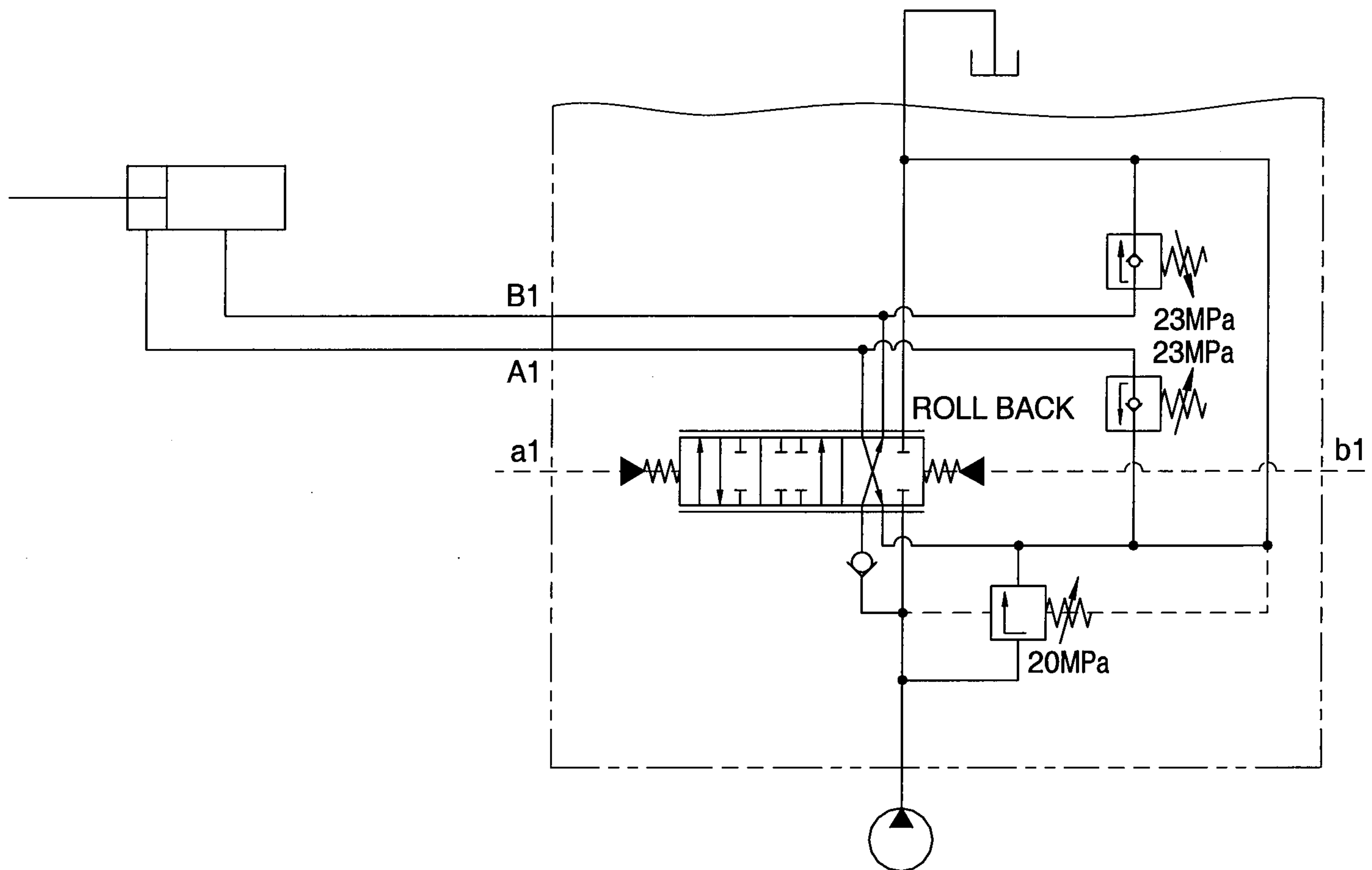

When the pilot pressure from remote control valve is supplied to the pilot port(b1), the spool moves to the left and the neutral passage is closed.

The oil supplied from the pump pushes up the load check valve(1) and flow into boom cylinder port(B1). The pump pressure reaches proportionally the load of cylinder and fine control finished by shut off of the neutral passage.

The return oil from cylinder port(A1) flows into the tank via the low pressure passage.



### (3) Dump position

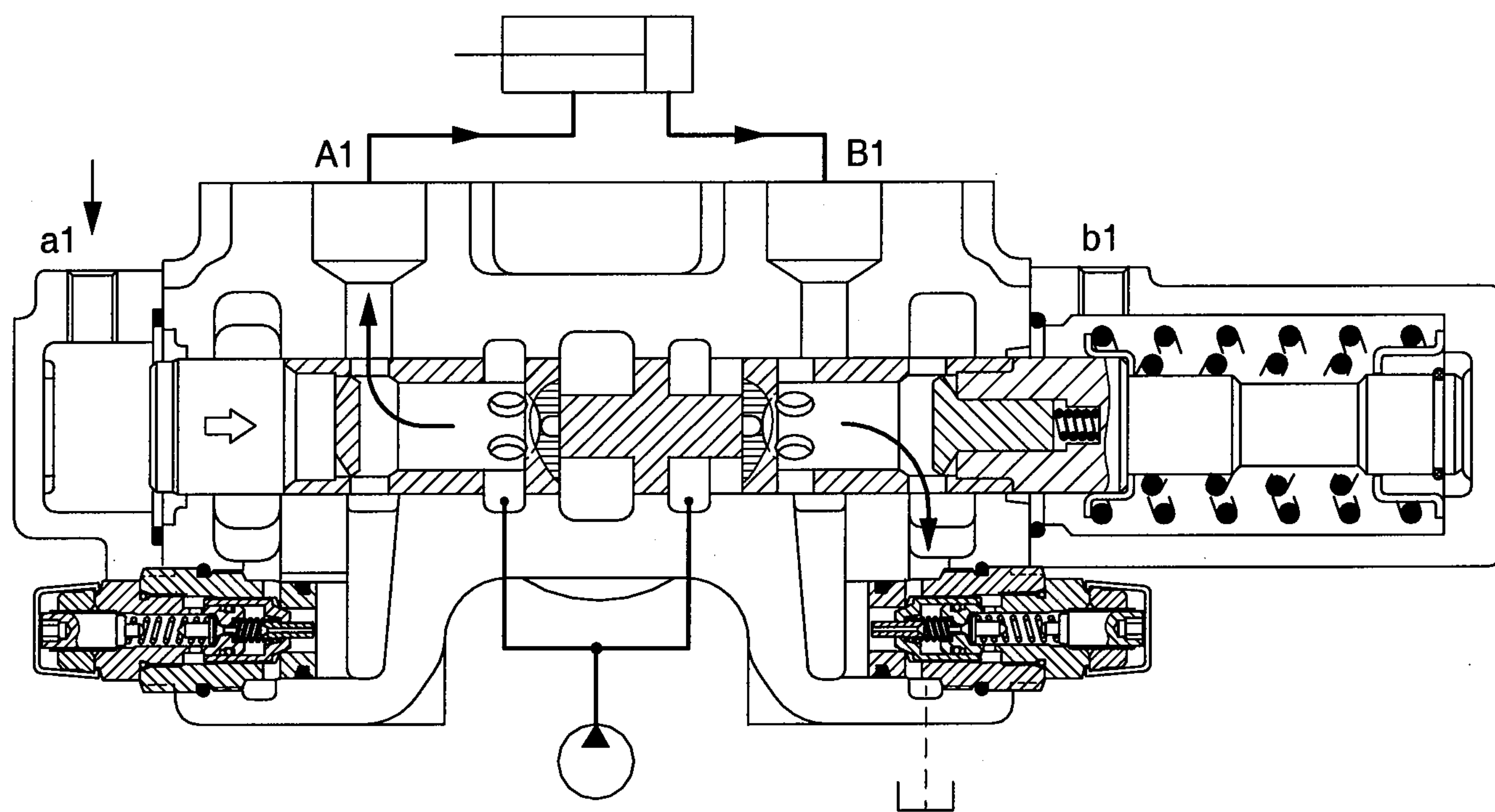
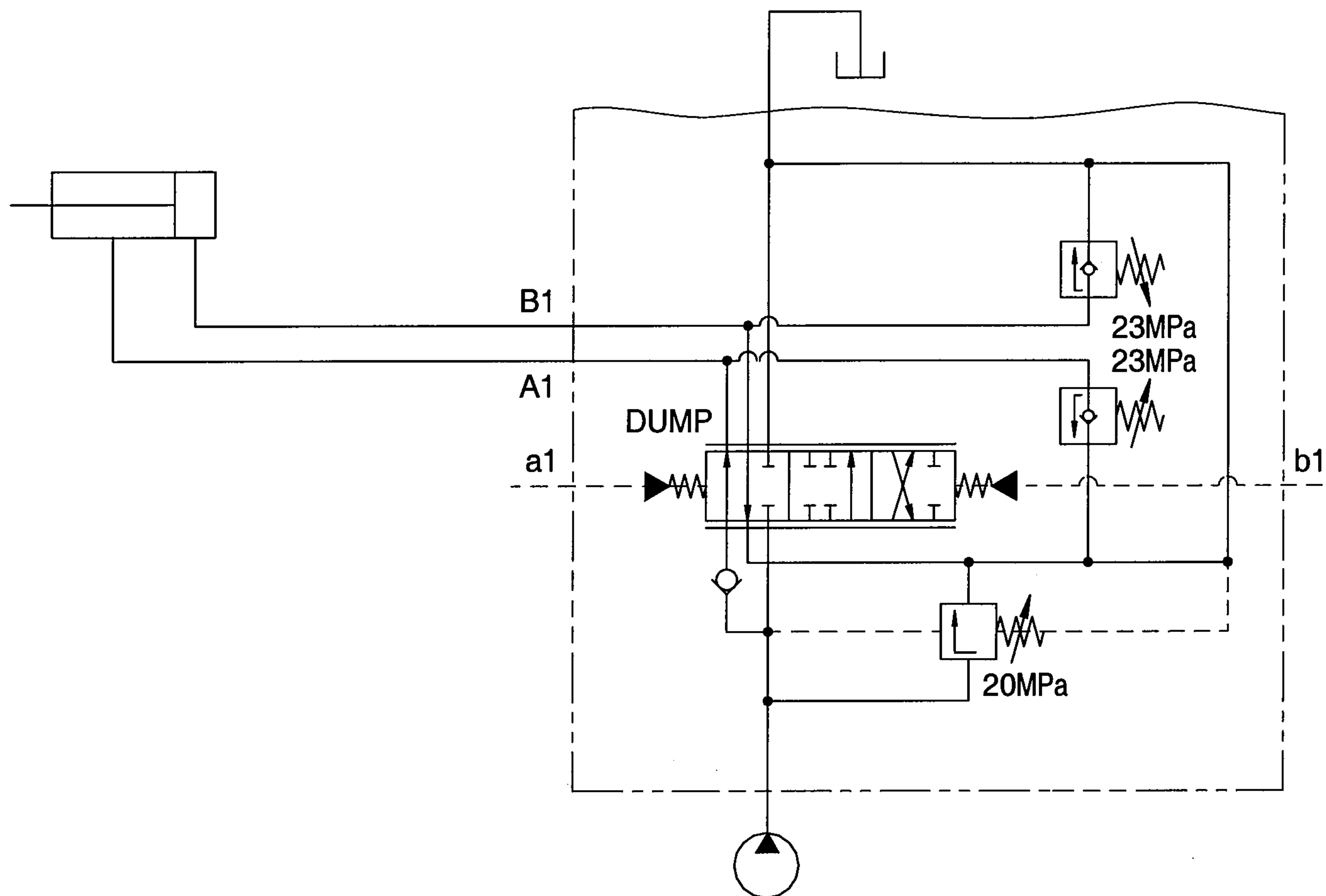

When the pilot pressure from remote control valve is supplied to the pilot port(a1), the spool moves to the right and the neutral passage is closed.

The oil supplied from the pump pushes up the load check valve(1) and flow into boom cylinder port(A1).

The pump pressure reaches proportionally the load of cylinder and fine control finished by shut off of the neutral passage.

The return oil from cylinder port(B1) flows into the tank via the low pressure passage.



### 3) MAIN RELIEF VALVE

- The main relief valve is installed at the inlet of the main control valve. When the oil goes above the set pressure, the relief valve drains the oil to the tank. In this way, it sets the maximum pressure in the hydraulic circuit and protects the circuit.
- The valve poppet(C) is connected via the throttle drillings(D1) and (D2) with the P port. If static pressure increases above the set pressure value, the valve poppet(C) opens and allows oil to flow freely to tank (Y). This oil generates a pressure drop in the spring chamber of the main poppet, the closing force of the spring(Z) is cancelled, and the main poppet(A) opens to allow the pump flow to flow to tank(T). Damped opening and closing is obtained by the throttled volumetric change.
- The set pressure can be varied by changing the tension of pressure spring (F). To change the set pressure, remove cap nut, loosen lock nut and turn adjustments screw(E) and follows.

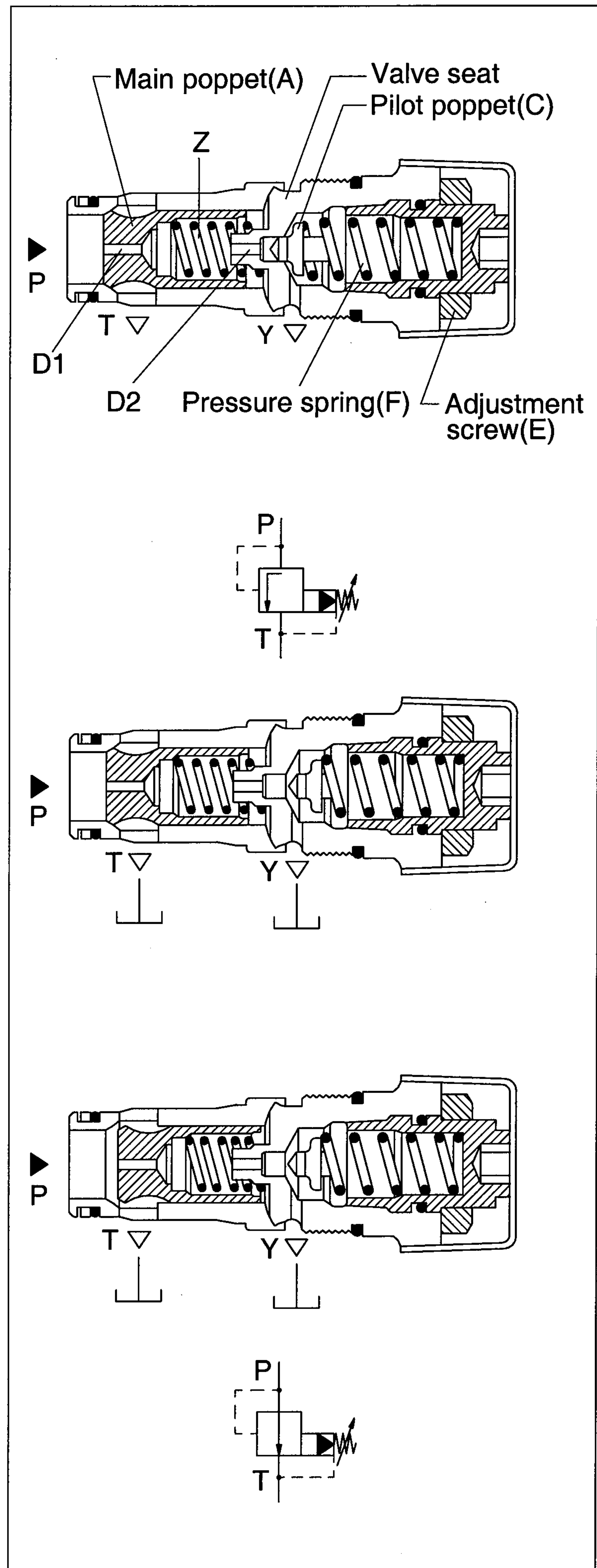



#### 4) OVERLOAD RELIEF VALVE

- The overload relief valve(Combined relief/ anticavitation valve) is in the boom cylinder and bucket cylinder circuit in the main control valve.

If shock causes any abnormally high pressure in the cylinder when the main valves is at neutral, the overload relief valve releases the abnormal pressure and protects the cylinder from damage.

- During normal operation, the poppet(2) is positioned against the body(1) to seal the workport(A) oil from the return(T) passage.
- As the circuit pressure approach the relief pressure setting, the pressure forces the pilot poppet(3) off its seat and allows oil to flow freely via the annular passage to tank. This oil generates a pressure drop in the spring chamber of the main poppet(2), the closing force of the spring(4) is cancelled. The main poppet(2) opens to allow flow from P to T.
- If cavitation in the workport occurs, the oil pressure in the workport drop below return pressure. Tank line return pressure oil works against the shoulder(A3) of the poppet to force it open against the spring and the workport pressure at (A2)-(A1).

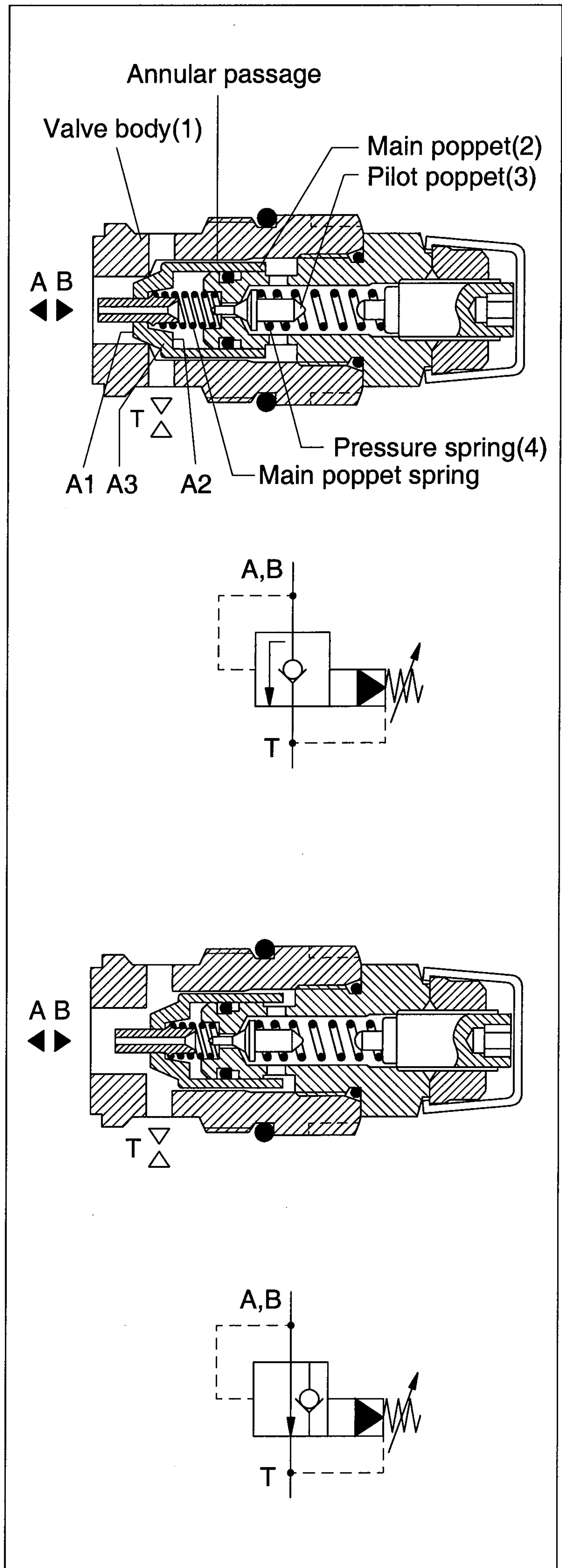



## 6. PILOT OIL SUPPLY UNIT

### 1) STRUCTURE

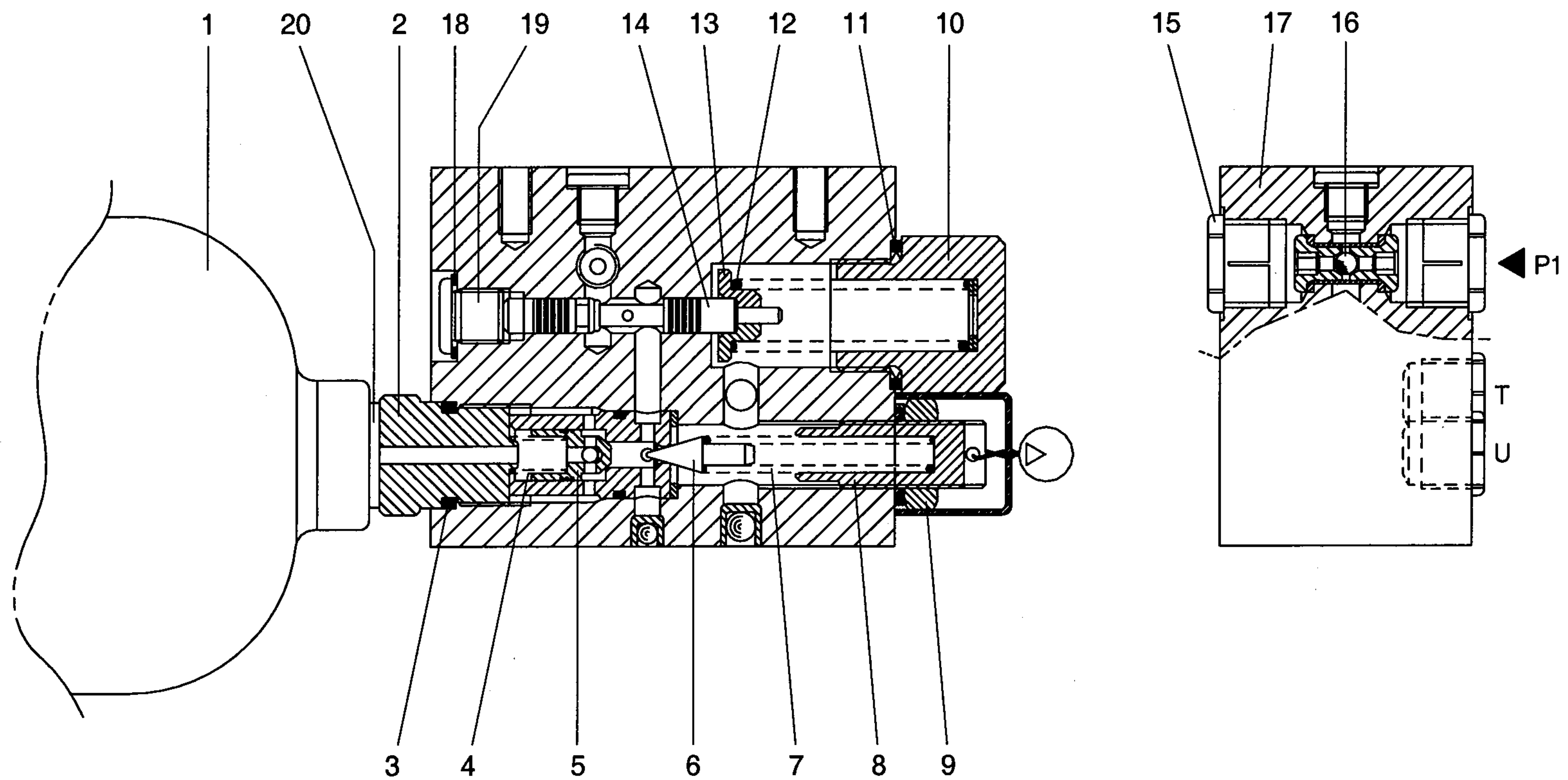

Port	Size
P1, P2	3/4" UNF
U, T	9/16" UND

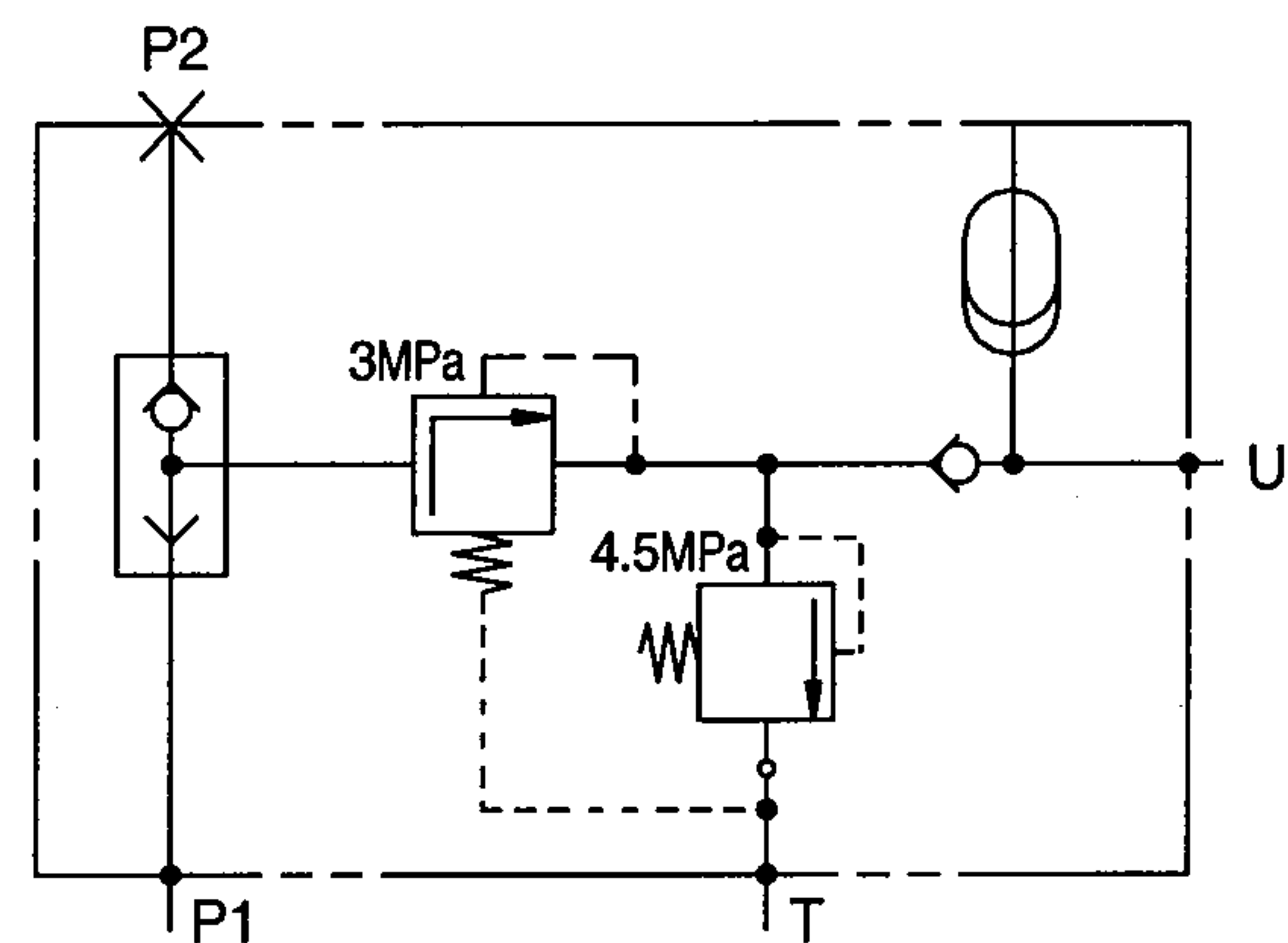

CIRCUIT DIAGRAM

- |   |             |    |                 |    |               |
|---|-------------|----|-----------------|----|---------------|
| 1 | Accumulator | 8  | Plug            | 15 | Plug          |
| 2 | Connector   | 9  | Nut             | 16 | Shuttle valve |
| 3 | O-ring      | 10 | Plug            | 17 | Housing       |
| 4 | Spring      | 11 | Seal            | 18 | O-ring        |
| 5 | Valve       | 12 | Spring          | 19 | Plug          |
| 6 | Valve       | 13 | Spring retainer | 20 | Washer        |
| 7 | Spring      | 14 | Spool           |    |               |



## (2) OPERATION

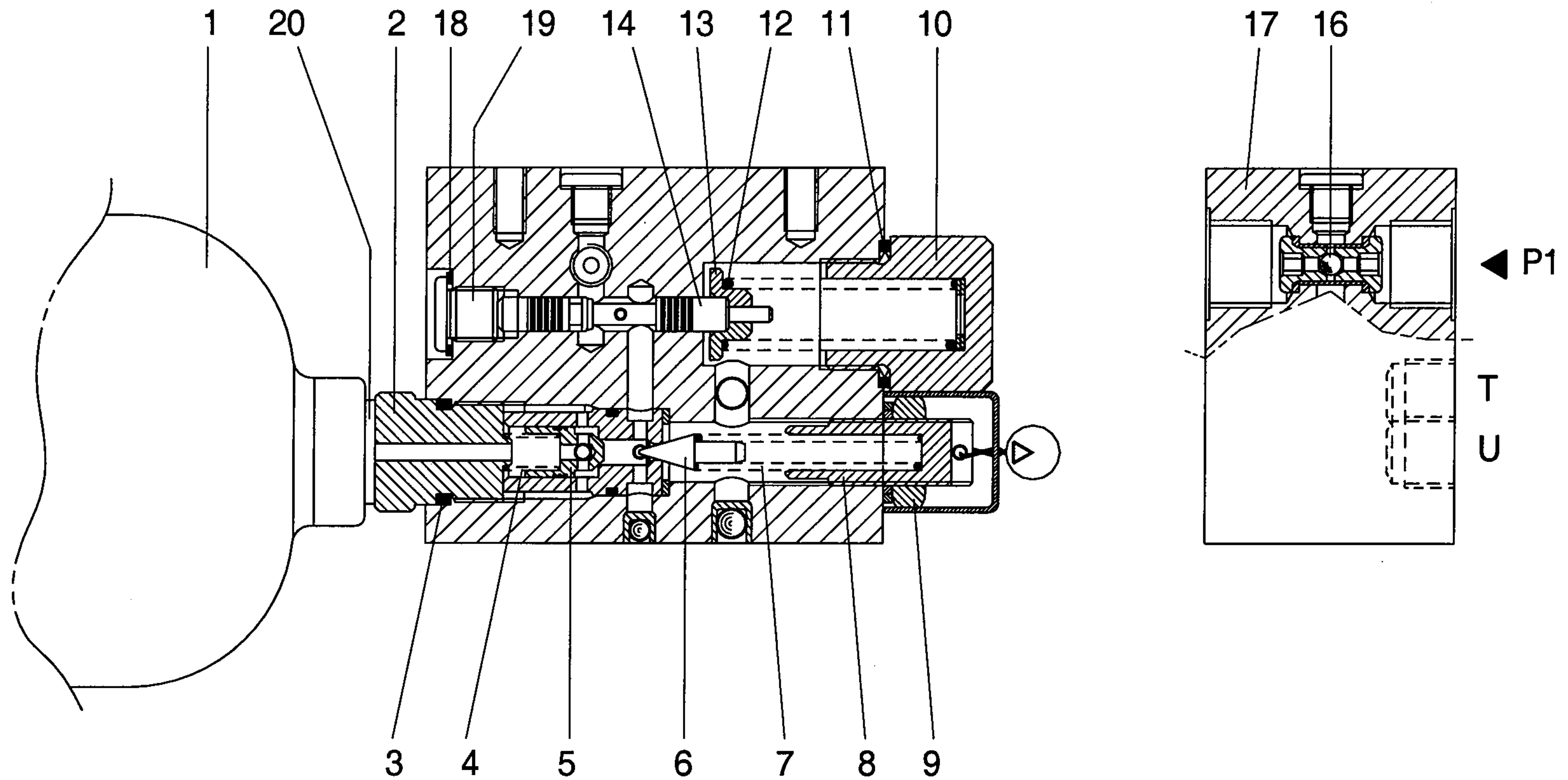

Pilot oil supply units are a combination of valves which reduce the pressure of medium and high pressure circuits in order to supply remote control valves with a low pressure supply of oil. They basically consist of the accumulator (1), the housing (17), a shuttle valve (16), a direct operated pressure relief valve (6) and a check valve (5).

Fluid flows from the high pressure via the shuttle valve (16) through port P1 into the unit and then to the secondary circuit. The pressure is reduced to the required level by means of spool (14) and passes via the check valve (5) into the accumulator (1) thus ensuring through port U greater control power and when necessary emergency operation should the main circuit be switched off or become defective.

Pressure relief valve (6) protects the pilot circuit should the spool (14) fail to operate. Check valve (5) prevents the accumulator emptying into the primary circuit.

Accumulator satisfies short term peak power demands and is a source of emergency power should the main circuit pressure fail.



## 7. SAFETY VALVE UNIT

### 1) STRUCTURE

The safety valve locks or permits pilot oil flow to the main control valve operation.

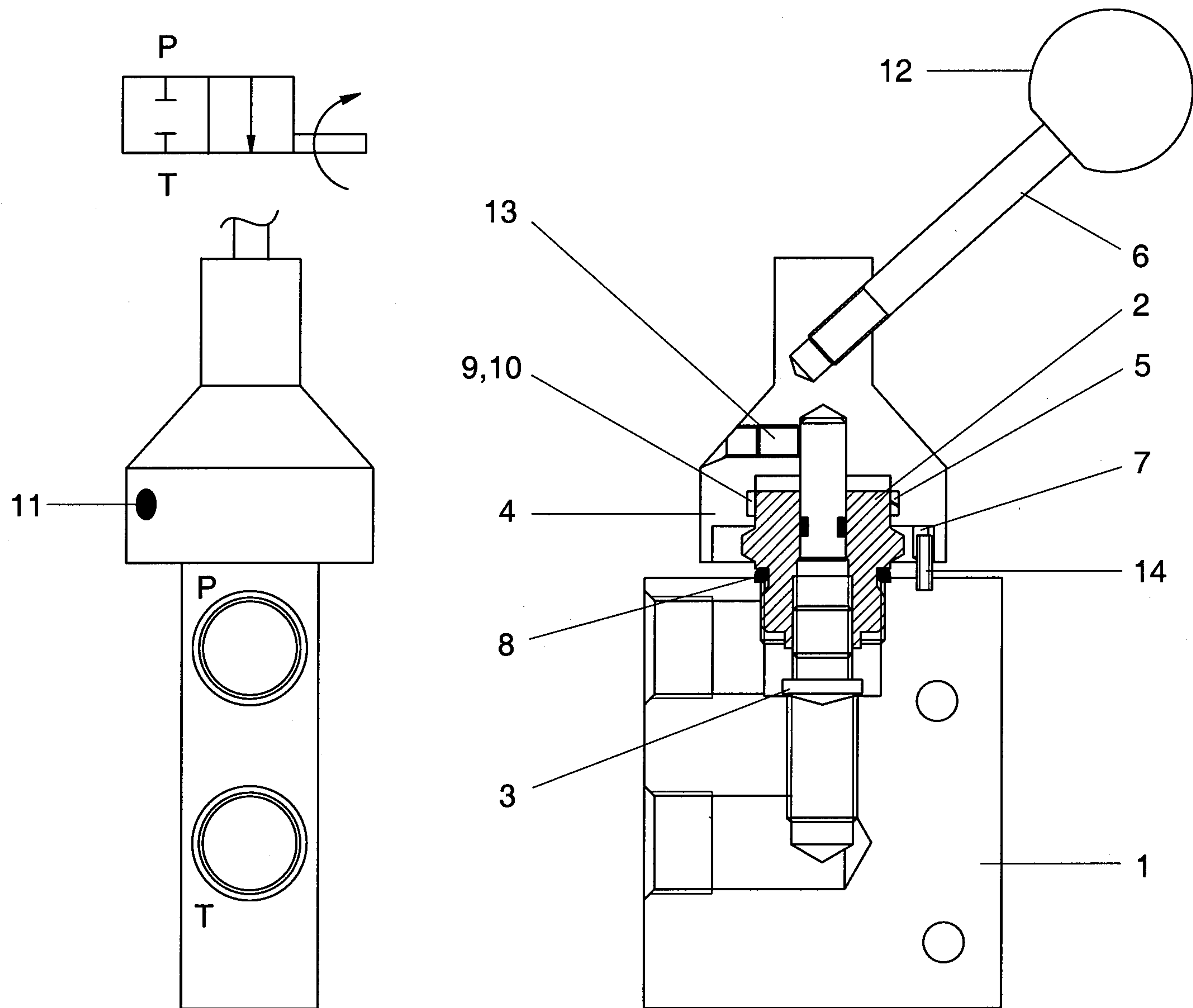

- |   |             |    |              |    |                  |
|---|-------------|----|--------------|----|------------------|
| 1 | Body        | 6  | Handle       | 11 | Spring plunger   |
| 2 | Retainer    | 7  | Spring ring  | 12 | Knob             |
| 3 | Adjust stem | 8  | O-ring       | 13 | Socket set screw |
| 4 | Housing     | 9  | O-ring       | 14 | Spring pin       |
| 5 | Clutch ring | 10 | Back up ring |    |                  |



## 8. BOOM AND BUCKET CYLINDER

The boom cylinders are two unit and the bucket cylinder is one unit. They use a bolt on rod guide.

The piston(12) threads on to the rod(2) and is retained by a nut(17) and set screw(18).

The piston seals against the tube(1) with piston seal(15). Two wear rings(16) are located on each side of the piston seal.

The gland(3, the rod guide) seals against the tube with an O-ring(10). The cylinder thread seals against the rod with a lip type buffer ring(7) and a rod seal(5). A dust wiper(8) cleans the rod when it is retracted.

### 1) BOOM CYLINDER

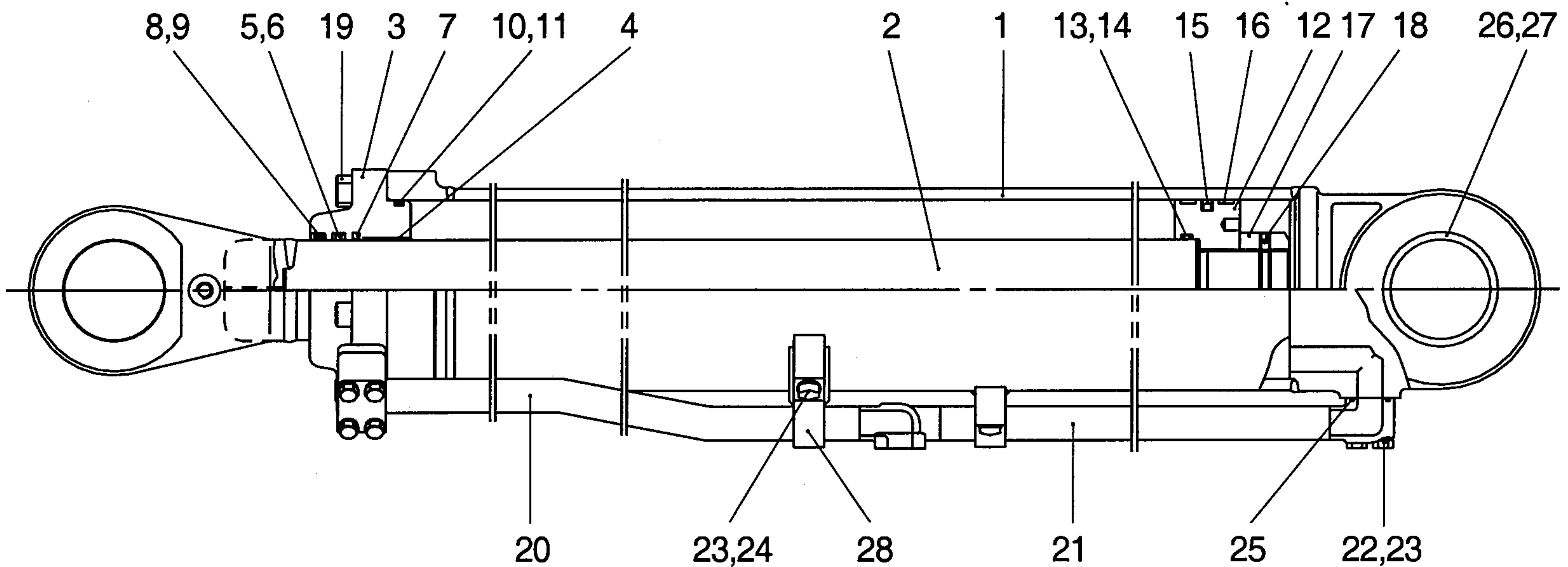

1	Tube assy	11	Back up ring	21	Pipe assy
2	Rod assy	12	Piston	22	Bolt
3	Gland	13	O-ring	23	Spring washer
4	Bushing	14	Back up ring	24	Bolt
5	Rod seal	15	Piston seal	25	O-ring
6	Back up ring	16	Wear ring	26	Bushing
7	Buffer ring	17	Piston nut	27	Dust seal
8	Dust wiper	18	Screw	28	Clamp
9	Snap ring	19	Bolt		
10	O-ring	20	Pipe assy		



## 2) BUCKET CYLINDER

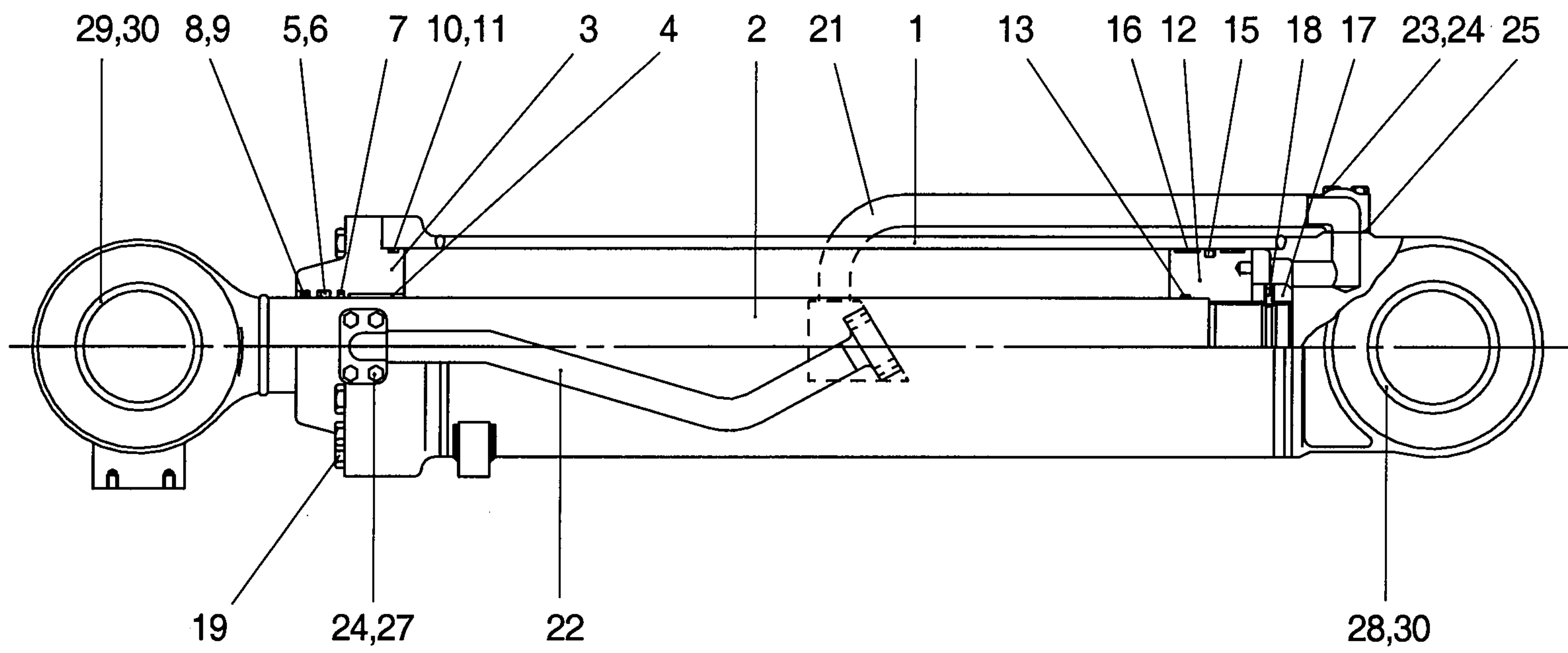

1	Tube assy	10	O-ring	21	Pipe assy
2	Rod assy	11	Back up ring	22	Pipe assy
3	Gland	12	Piston	23	Bolt
4	Bushing	13	O-ring	24	Spring washer
5	Rod seal	15	Piston	25	O-ring
6	Back up ring	16	Wear ring	27	Bolt
7	Buffer ring	17	Piston nut	28	Bushing
8	Dust wiper	18	Screw	29	Bushing
9	Snap ring	19	Bolt	29	Dust seal



## 9. HYDRAULIC OIL TANK

### 1) STRUCTURE

- The oil from the hydraulic tank is sent from the pump through control valve to the cylinders. In the return circuit, the oil from various parts merges.
- A part of oil is cooled in the oil cooler, passes through the hydraulic filter and returns to the hydraulic tank(1).
- If the hydraulic return oil filter becomes clogged, return filter bypass valve(3) acts to allow the oil to return directly to the hydraulic tank(1). This prevents damage to the hydraulic filter(2). The bypass valve(3) is also actuated when negative pressure is generated in the circuit.

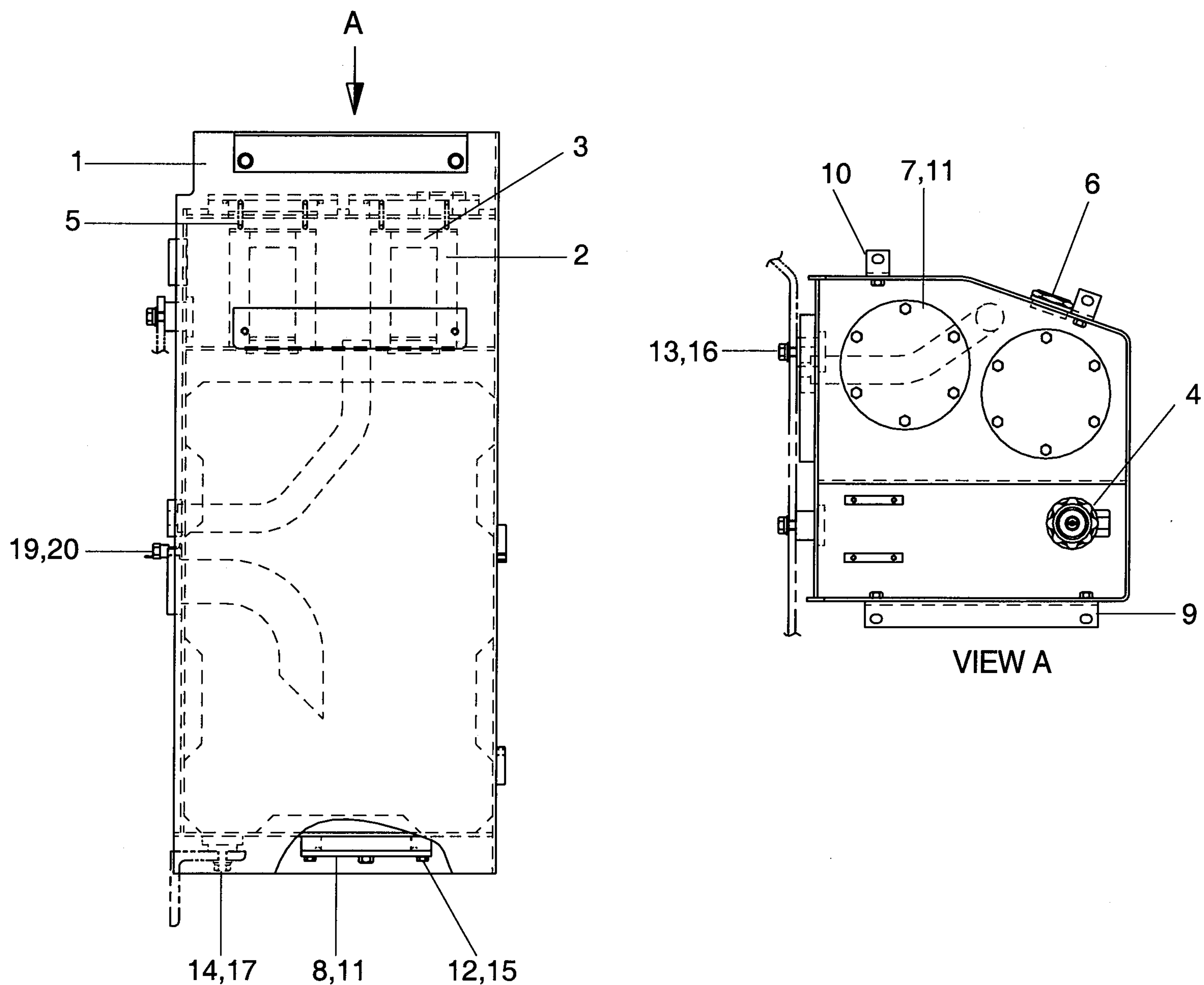

1	Hydraulic tank wa	8	Cover	15	Spring washer
2	Element	9	Plate	16	Hardened washer
3	By pass valve	10	Plate	17	Hardened washer
4	Air breather	11	O-ring	19	Overheat switch
5	Spring	12	Bolt	20	O-ring
6	Sight gauge	13	Bolt		
7	Cover	14	Bolt		



## 2) RETURN OIL FILTER BYPASS VALVE

### (1) When the filter is clogged

Bypass valve(1) is opened and the oil returns directly to the tank without passing through the filter.

Bypass valve set pressure :  $1.36\text{kg/cm}^2$   
(19.3psi)

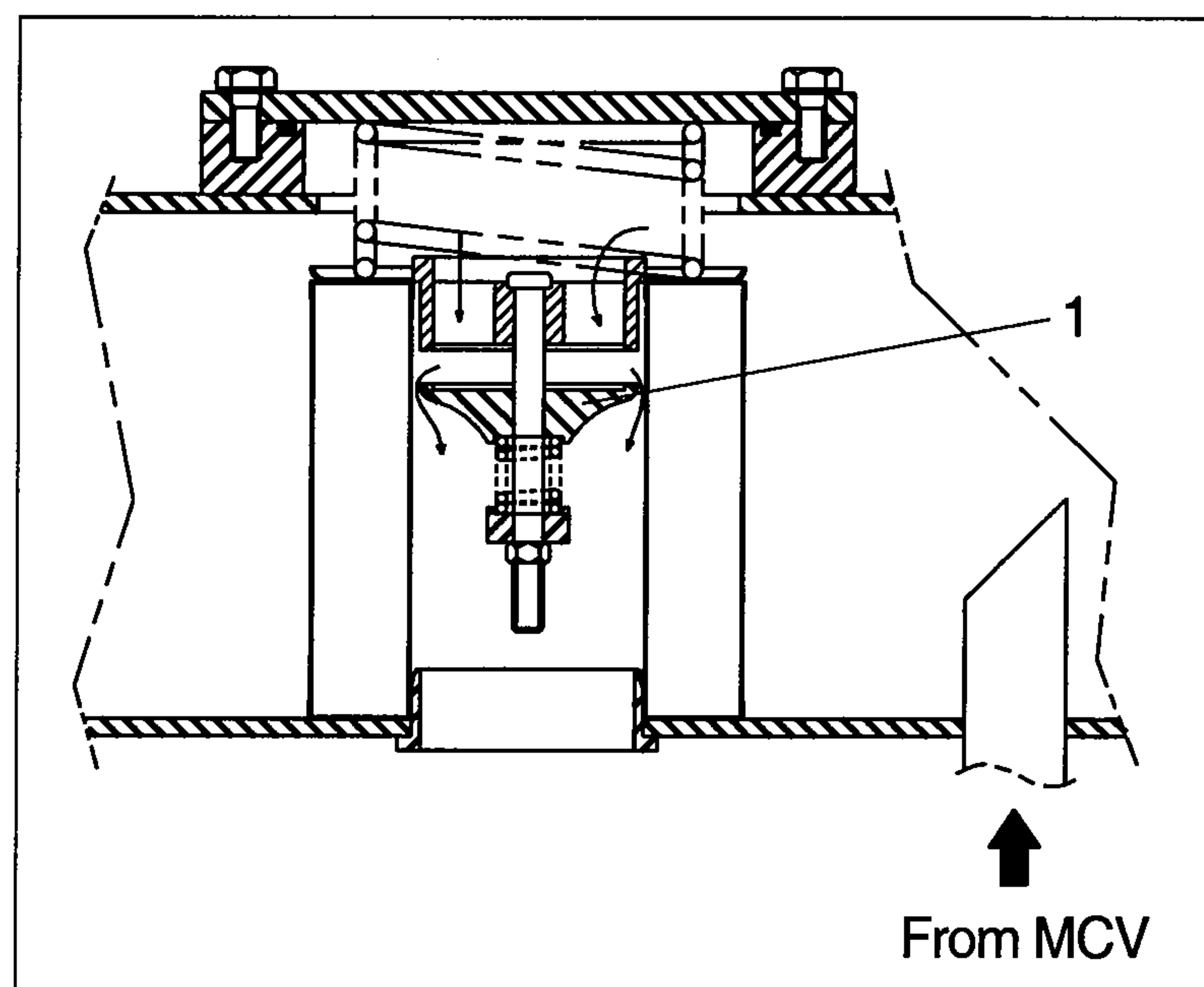



### 3) AIR BREATHER

The air breather is equipped with the capacity to perform three functions simultaneously-as an air filter, breathing valve, and as a lubrication opening.

#### (1) Preventing negative pressure inside the tank

The tank is a pressurized sealed type, so negative pressure is formed inside the hydraulic tank when the oil level drops during operations. When this happens, the difference in pressure between the tank and the outside atmospheric pressure opens the poppet in the breather, and air from the outside is let into the tank or prevent negative pressure.

#### (2) Preventing excessive pressure inside the tank

When the hydraulic cylinder is being used, the oil level in the hydraulic system increases and as temperature rises. If the hydraulic pressure rises above the set pressure, breather is actuated to release the hydraulic pressure inside the tank.

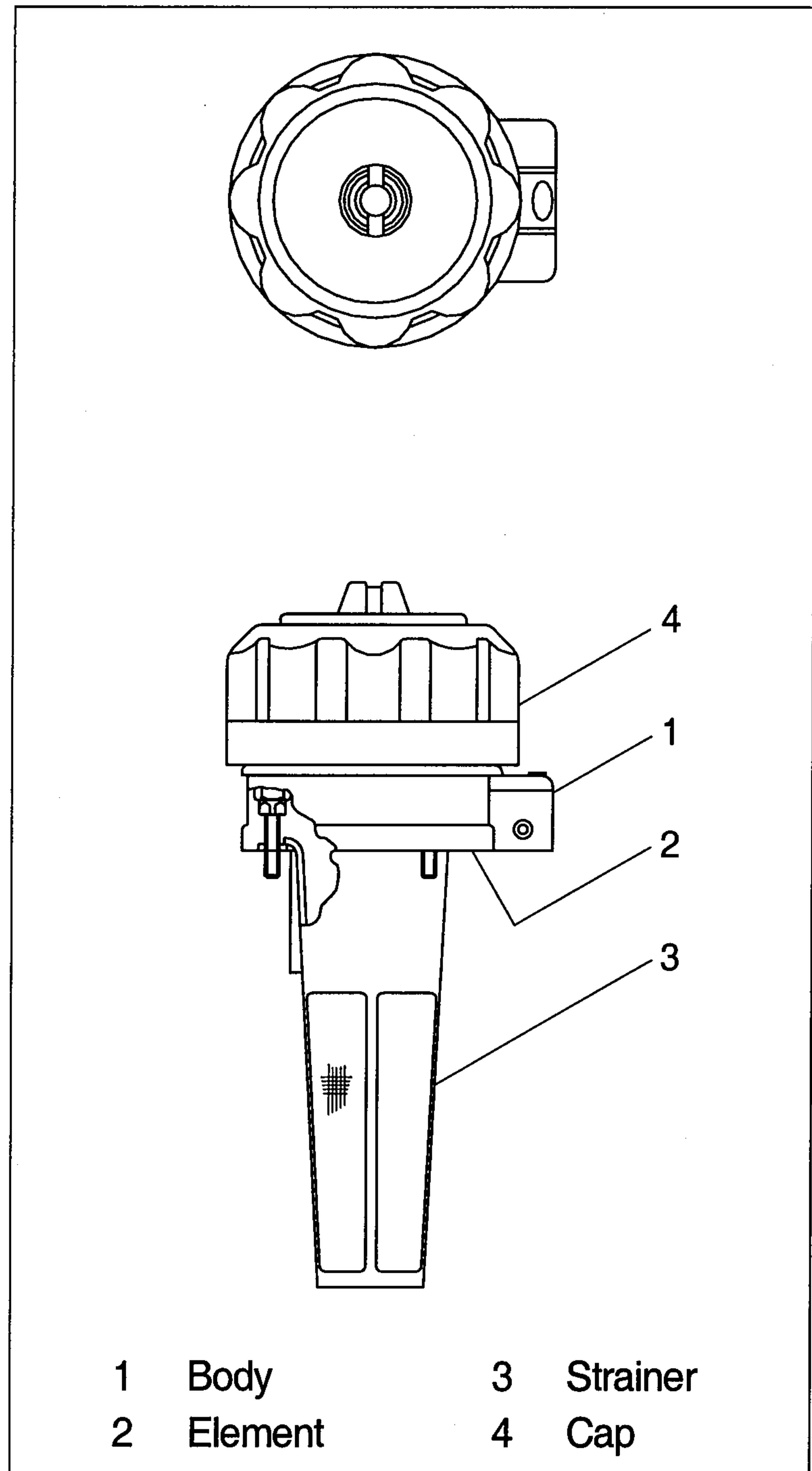



## 10. ACCUMULATOR

The accumulator is installed at the pilot oil supply unit. When the boom is left the raised position, and the control levers are operated with the engine stopped the pressure of the compressed nitrogen gas inside the accumulator sends pilot pressure to the control valve to actuate it and allow the boom and bucket to come down under their own weight.

Type of gas	Nitrogen gas(N <sub>2</sub> )
Volume of gas	0.75 l (0.2 U.S.gal)
Charging pressure of gas	16kg/cm <sup>2</sup> (228psi)
Max actuating pressure	30kg/cm <sup>2</sup> (427psi)

