

GROUP 2 ELECTRICAL CIRCUIT

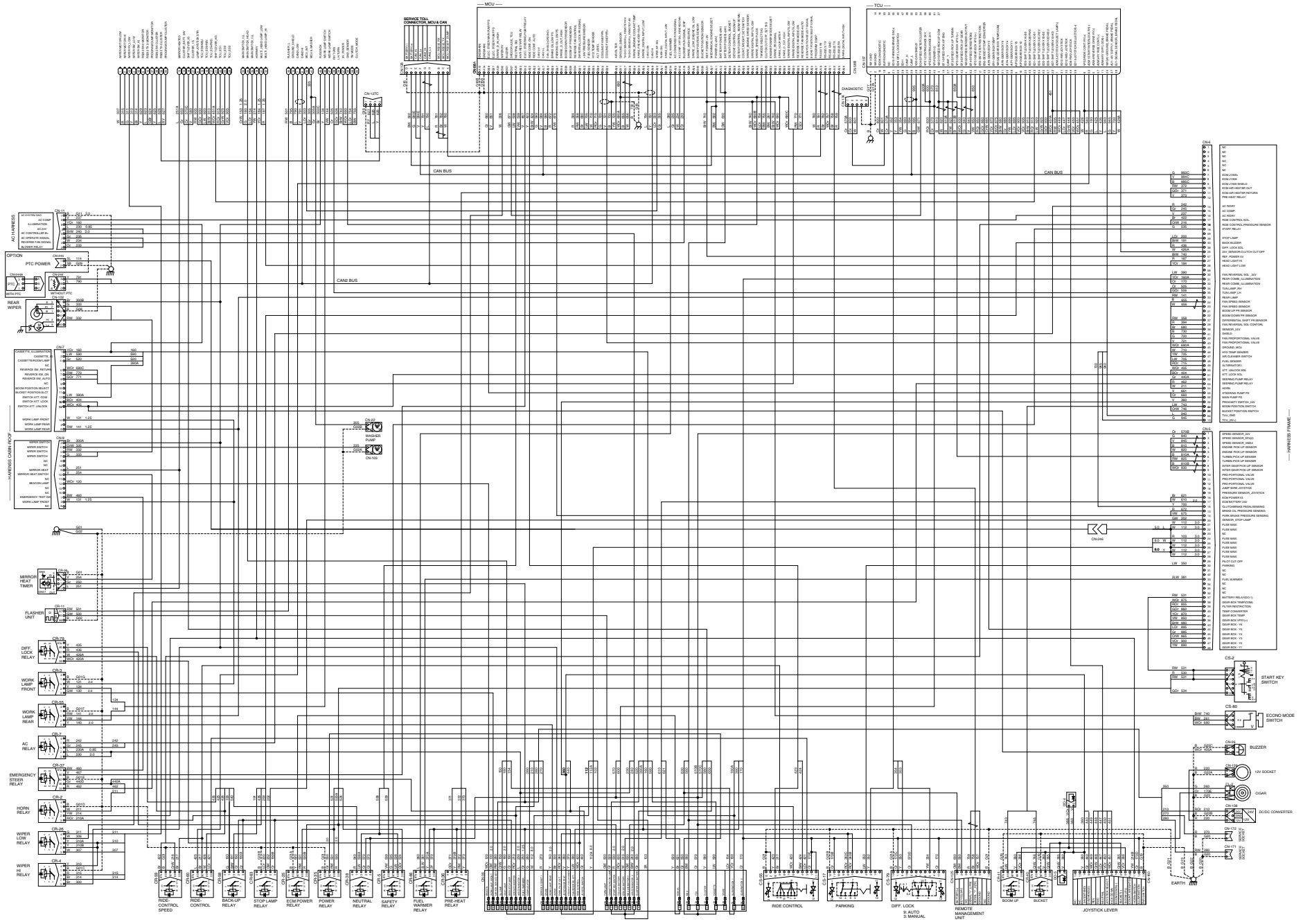

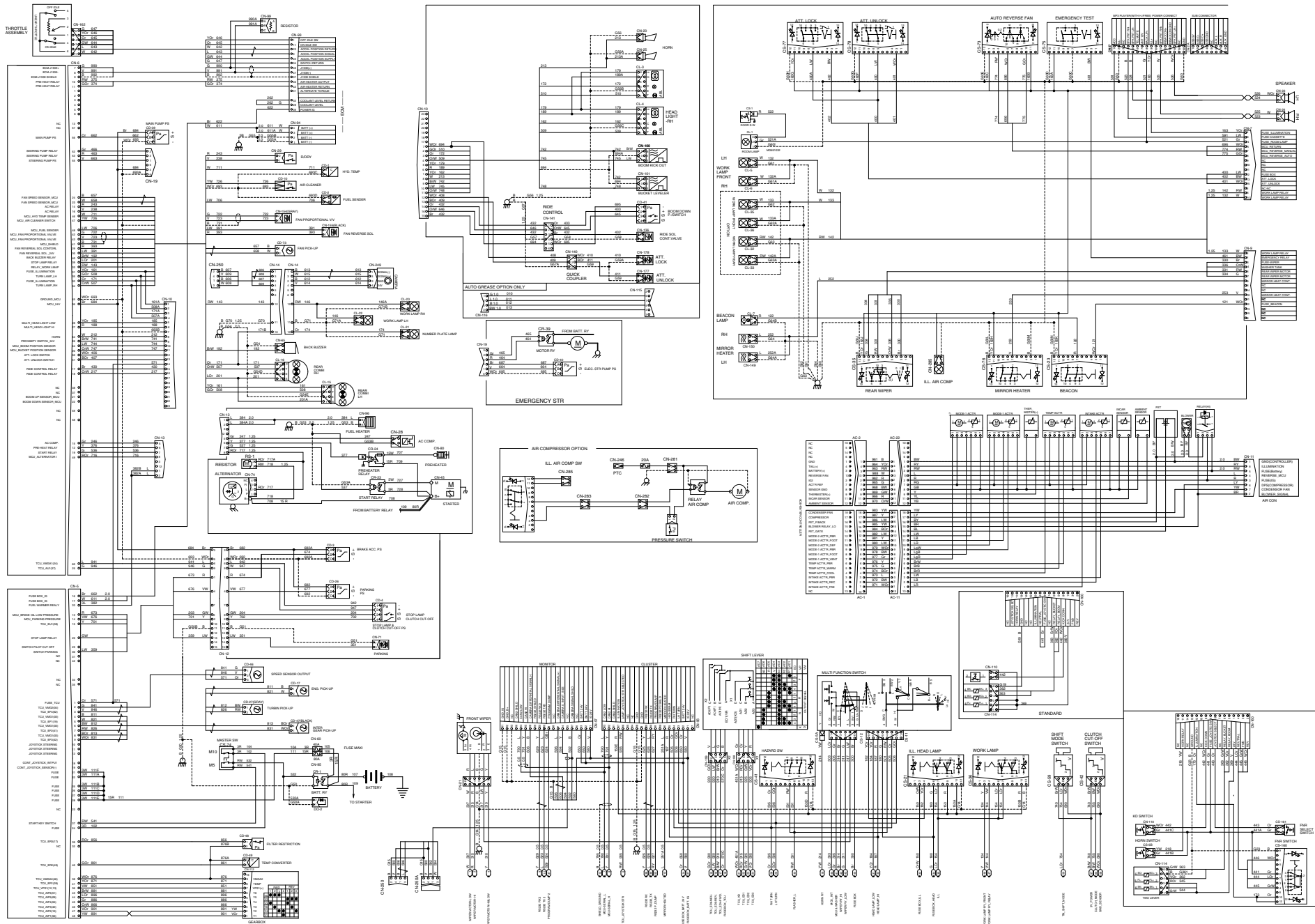



1. ILLUMINATION CIRCUIT

1) OPERATING FLOW

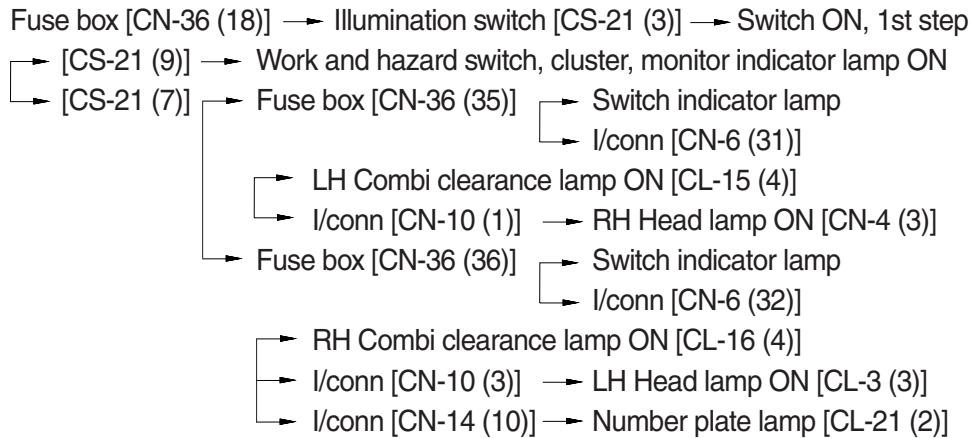

2) CHECK POINT

Engine	Key switch	Check point	Voltage
OFF	ON	① - GND (switch input) ② - GND (switch output) ③ - GND (to light)	20~25V

※ GND : Ground

ILLUMINATION CIRCUIT

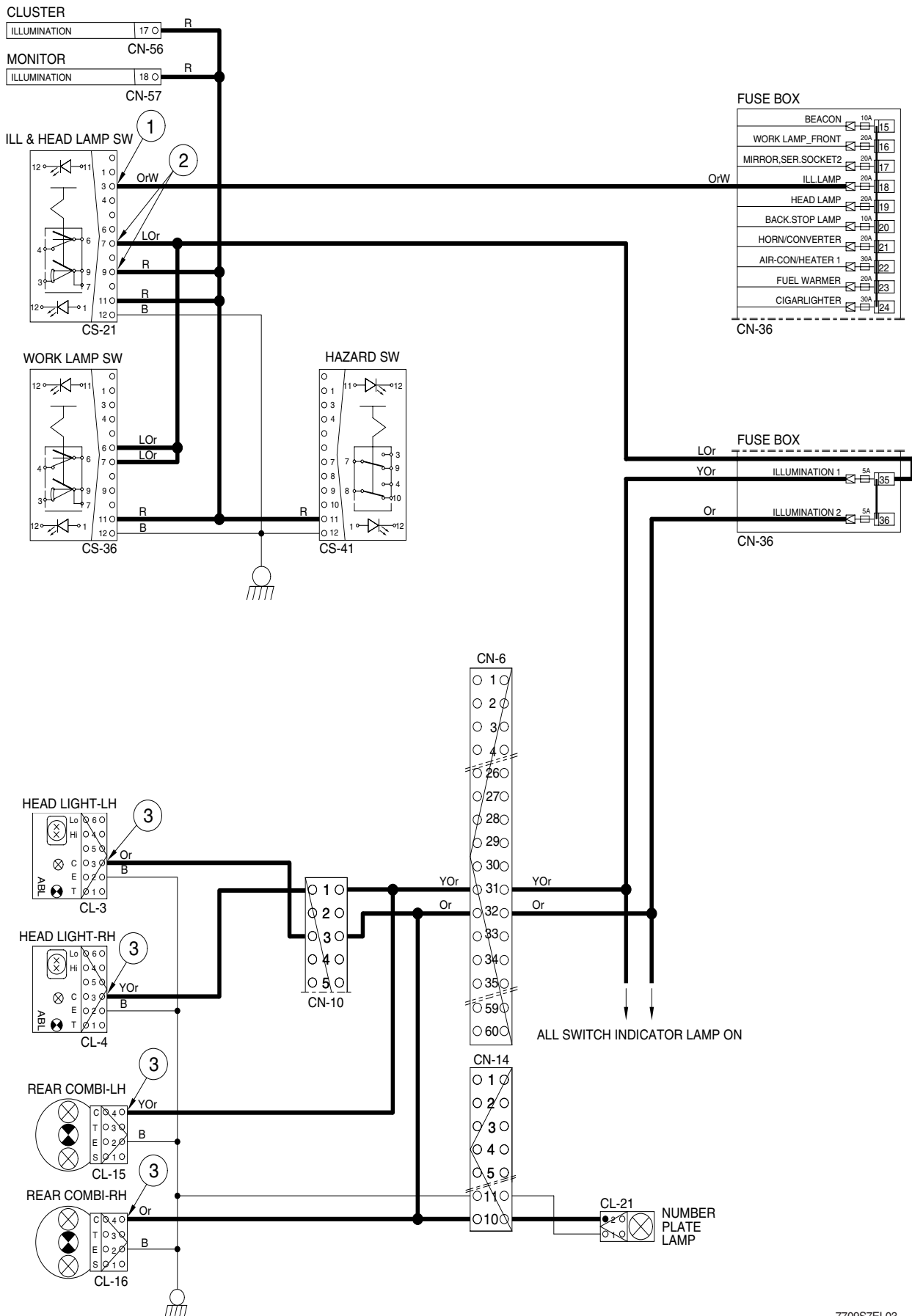

7709S7EL03

2. HEAD LIGHT CIRCUIT

1) OPERATING FLOW

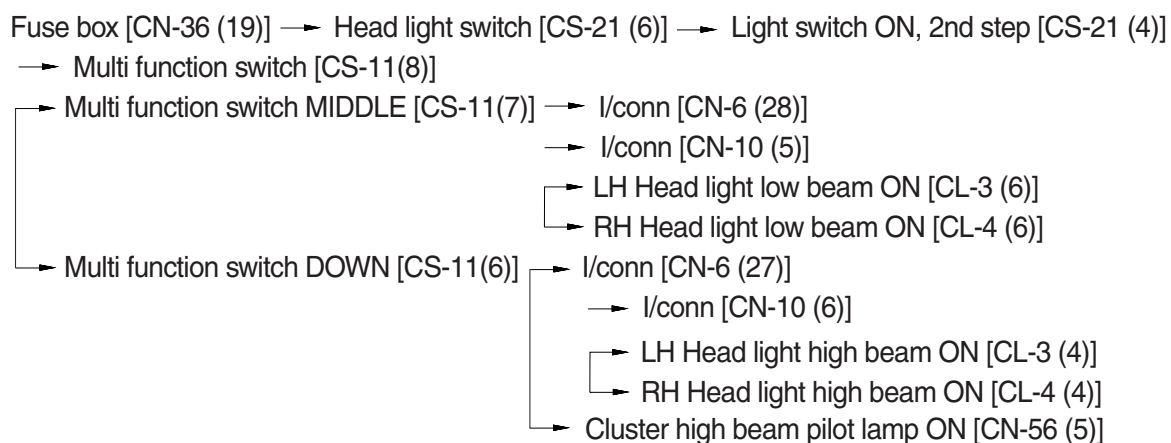

2) CHECK POINT

Engine	Key switch	Check point	Voltage
OFF	ON	① - GND (switch input) ② - GND (switch output) ③ - GND (multi function input) ④ - GND (multi function output) ⑤ - GND (multi function output) ⑥ - GND (low beam) ⑦ - GND (high beam) ⑧ - GND (passing B ⁺)	20~25V

※ GND : Ground

HEAD LIGHT CIRCUIT

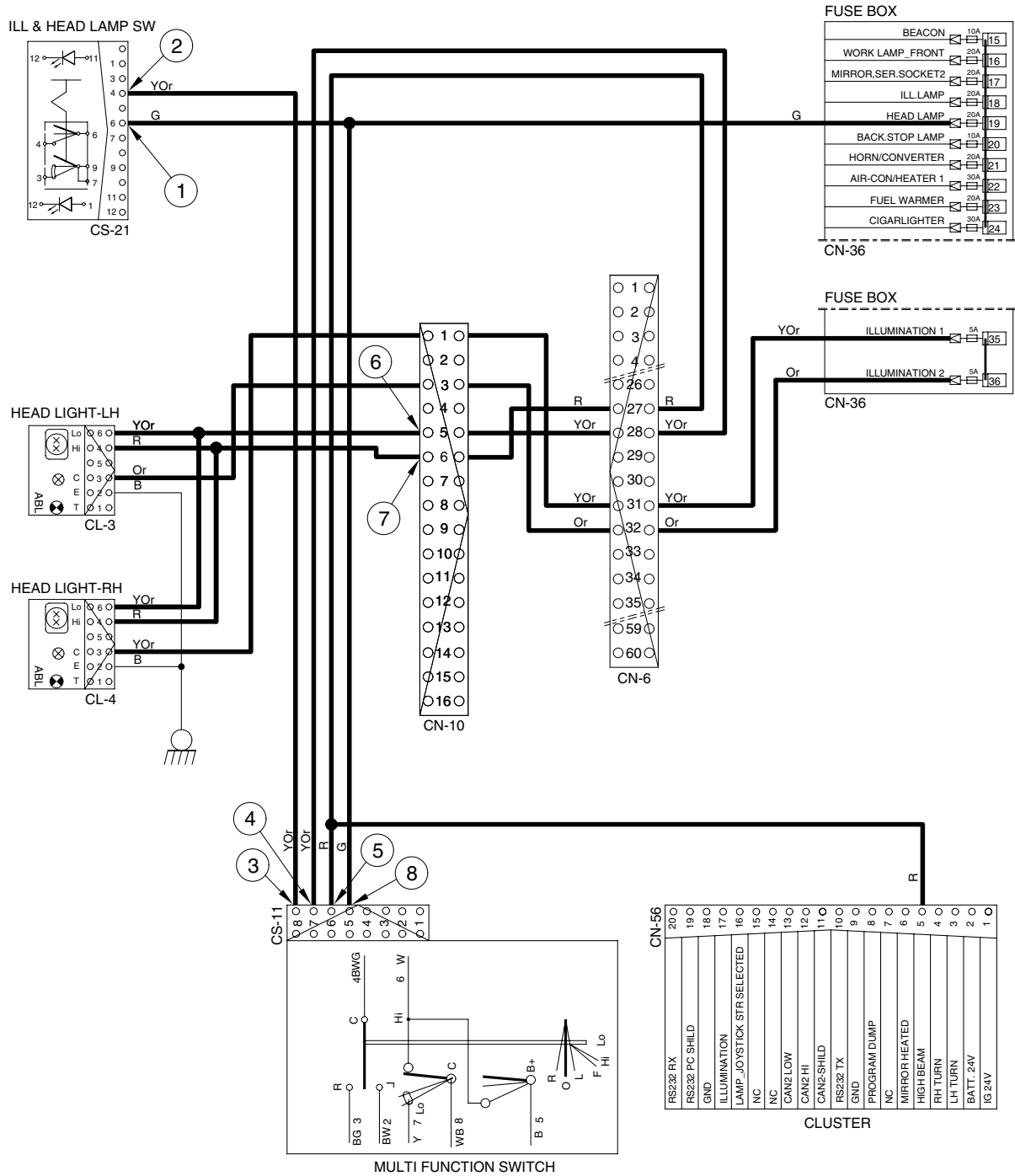

7709SEL04

3. WORK LIGHT SWITCH

1) OPERATING FLOW

※ Illumination switch : ON position (1st step)

(1) Work lamp switch ON (1st step)

ILL & head lamp switch [CS-21 (9)] → Work lamp switch indicate lamp ON
 → Work lamp switch [CS-36 (7)→(3)]
 → Front work lamp relay[CR-3 (2)→(5)] → I/conn [CN-7 (14)]
 → LH Front work lamp ON [CL-5 (1)]
 → RH Front work lamp ON [CL-6 (1)]

(2) Work lamp switch (2nd step)

Work lamp switch [CS-36 (6) → (4)] → Rear work lamp relay [CR-55 (2)→(5)]
 → I/conn [CN-6 (33)] → I/conn [CN-14 (12)] → LH Rear work lamp ON [CL-22 (1)]
 → RH Rear work lamp ON [CL-23 (1)]

2) CHECK POINT

Engine	Key switch	Check point	Voltage
OFF	ON	① - GND (work lamp power input) ② - GND (work lamp power output) ③ - GND (front work lamp) ④ - GND (rear work lamp)	20~25V

※ GND : Ground

WORK LIGHT SWITCH

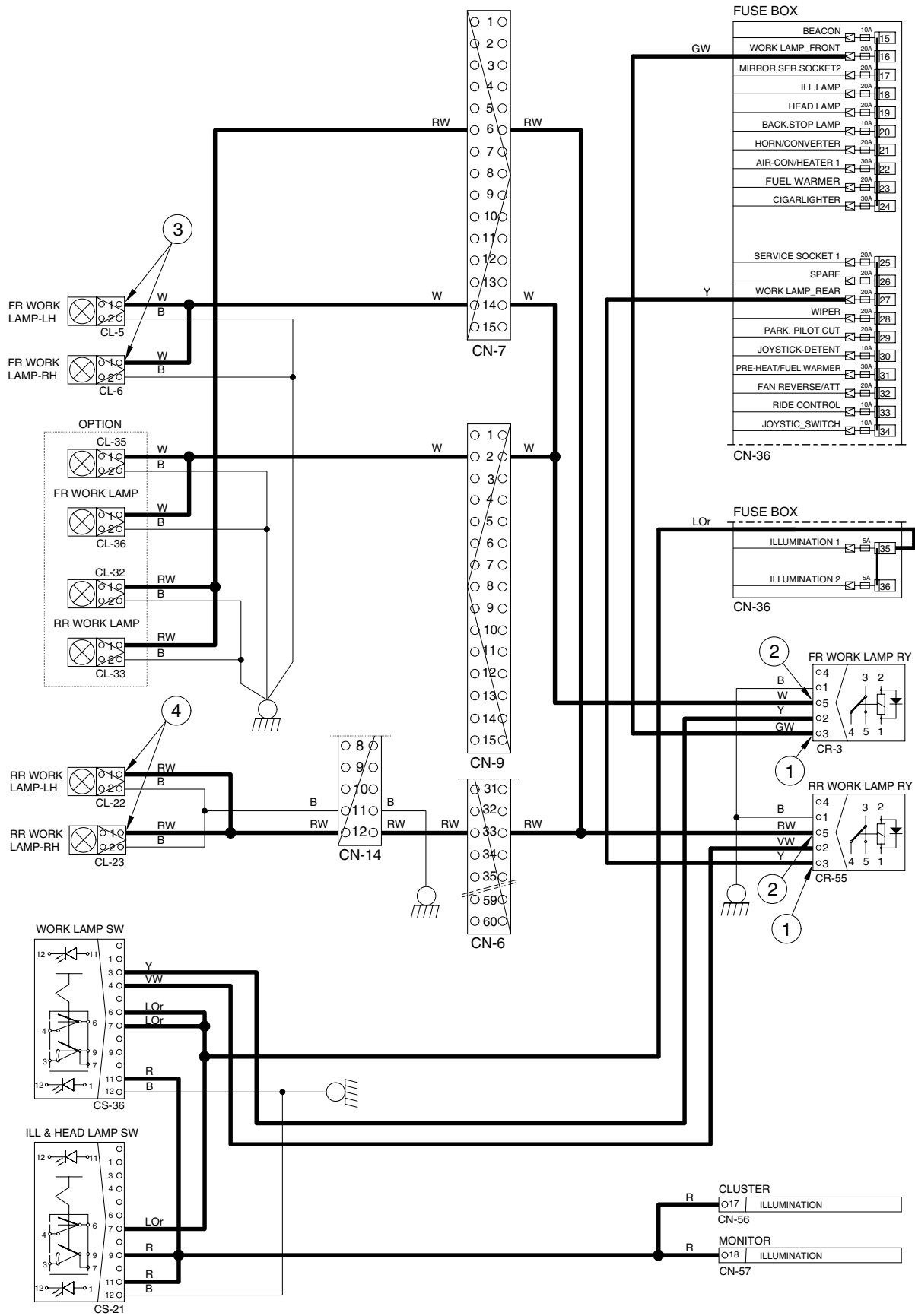

4. STARTING CIRCUIT

1) OPERATING FLOW

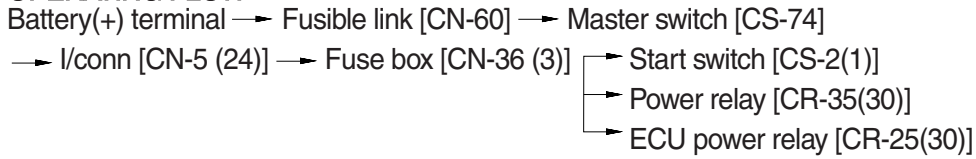

※ The gear selector lever is neutral position. It is necessary condition before the starting.
 The gear selector has an output signal which is activated whenever the shift lever is in the neutral position. This signal can be used to control a relay and prevent engine from starting whenever the shift lever is not in the neutral position.

(1) When start key switch is in ON position

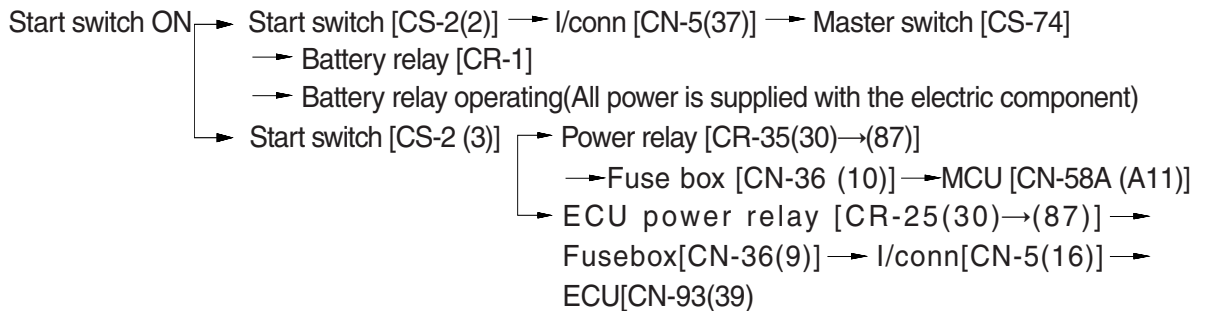

(2) When start key switch is in START position

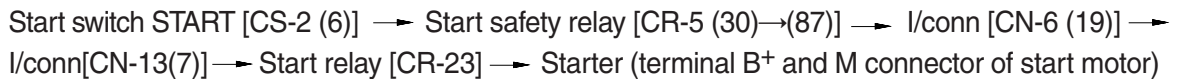

2) CHECK POINT

Engine	Key switch	Check point	Voltage
Running	ON	① - GND (battery B ⁺) ② - GND (fusible link) ③ - GND (start key B terminal) ④ - GND (start key BR terminal) ⑤ - GND (i/conn CN-5 (37)) ⑥ - GND (start key C terminal) ⑦ - GND (start safety relay output) ⑧ - GND (start key ACC terminal)	20~25 V

※ GND : Ground

※ MCU : Machine control unit

STARTING CIRCUIT

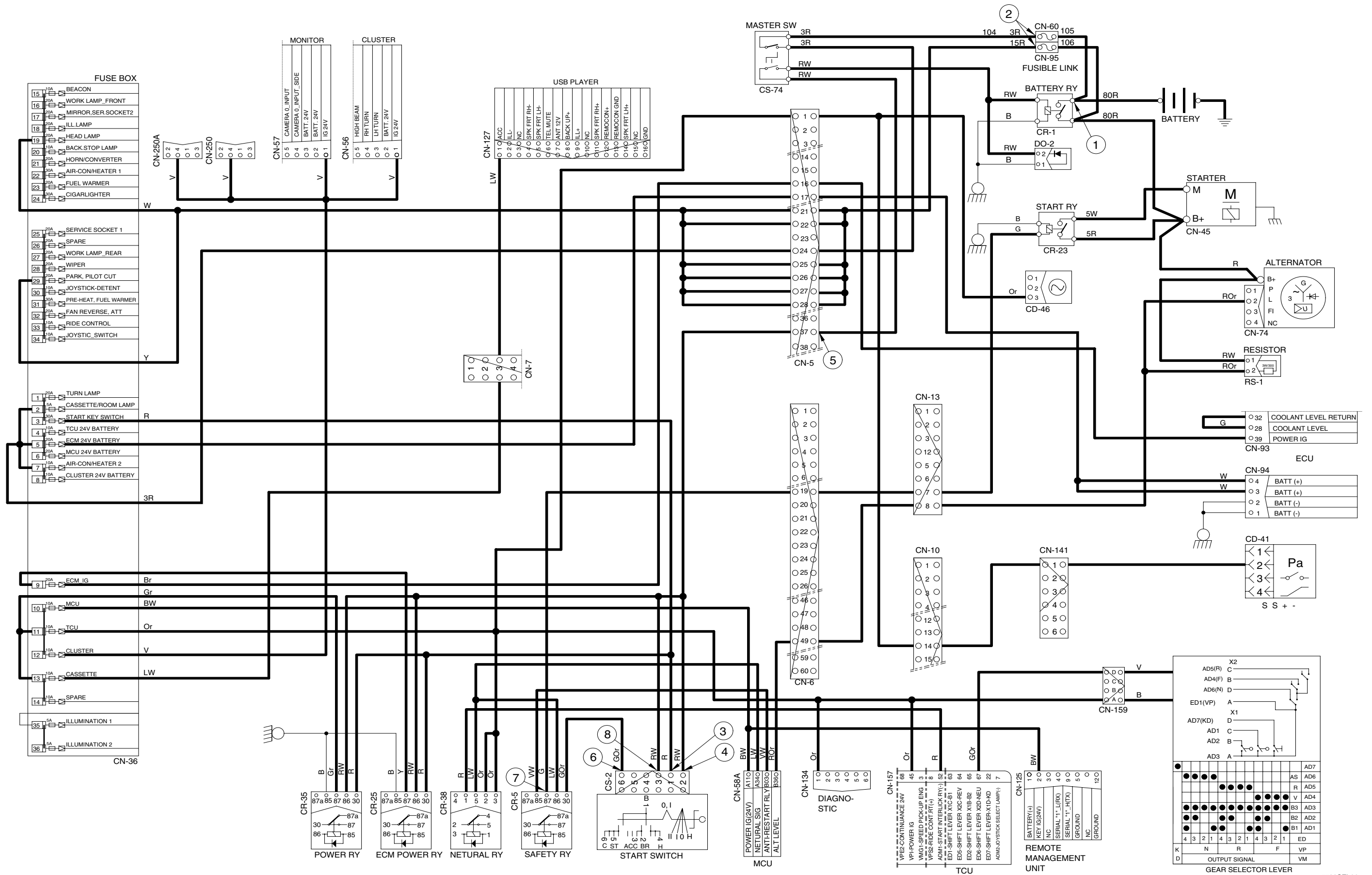

5. CHARGING CIRCUIT

When the starter is activated and the engine is started, the operator releases the key switch to the ON position.

Charging current generated by operating alternator flows into the battery through the battery relay (CR-1).

The current also flows from alternator to each electrical component and controller through the fuse box.

1) OPERATING FLOW

(1) Warning flow

Alternator [CN-74 (2)] → I/conn [CN-13 (8)] → I/conn [CN-6 (49)] → MCU [CN-58A (B36)]
 → Cluster charge warning lamp ON

(2) Charging flow

Alternator → Starter [CN-45 (B⁺)] → Battery relay [CR-1]
 → Battery(+) terminal → Charging
 → Fusible link [CN-60] → Master switch [CS-74] → I/conn [CN-5 (24)]
 → Fuse box [CN-36]
 → Fusible link [CN-95] → I/conn [CN-5 (21~28)] → Fuse box [CN-36]

2) CHECK POINT

Engine	Key switch	Check point	Voltage
OFF	ON	① - GND (battery) ② - GND (battery relay) ③ - GND (alternator B ⁺) ④ - GND (alternator 2) ⑤ - GND (MCU) ⑥ - GND (fuse box)	20~28V

※ GND : Ground

※ MCU : Machine control unit

CHARGING CIRCUIT

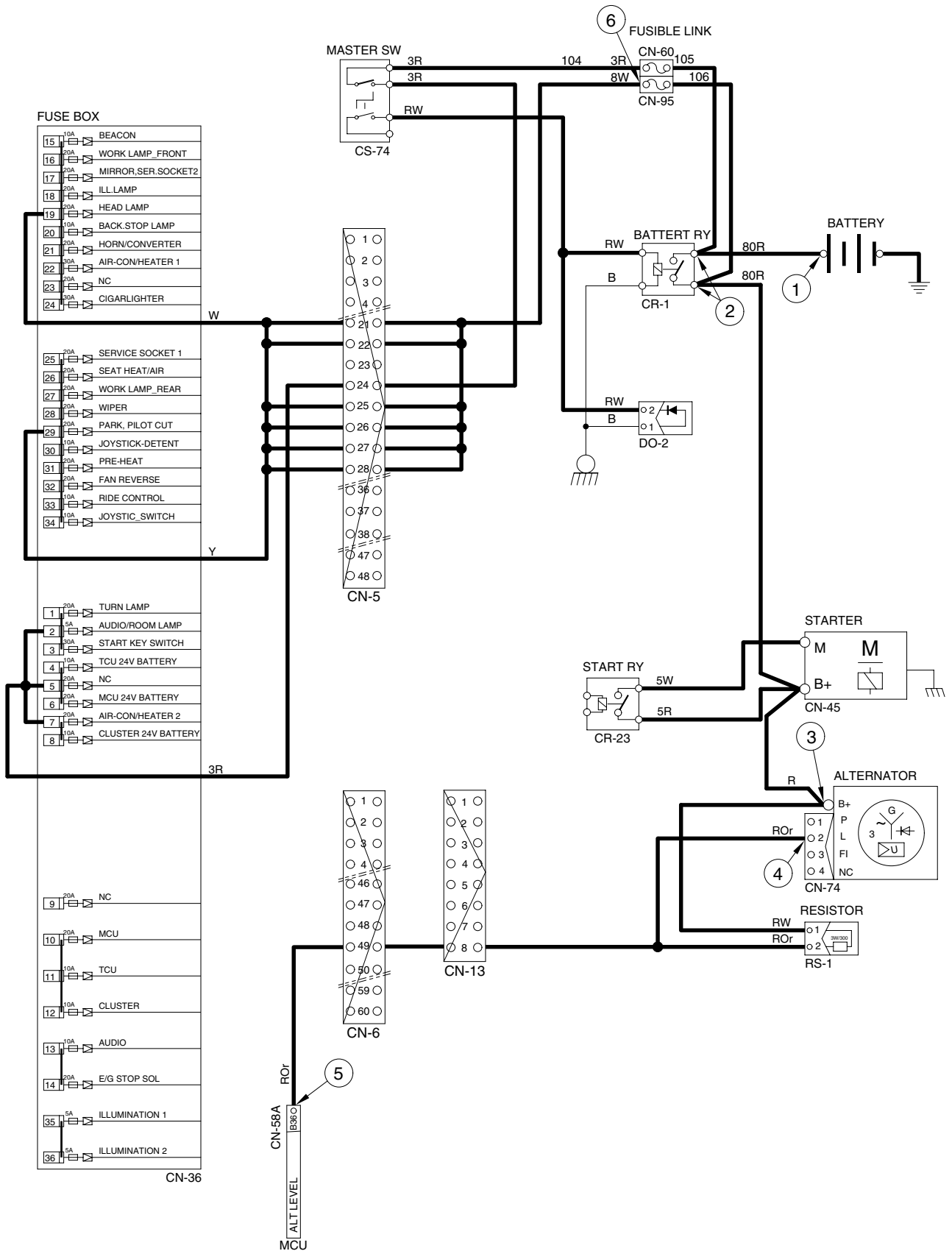

7609S7EL07

6. ELECTRIC PARKING CIRCUIT

1) OPERATING FLOW

(1) Parking OFF

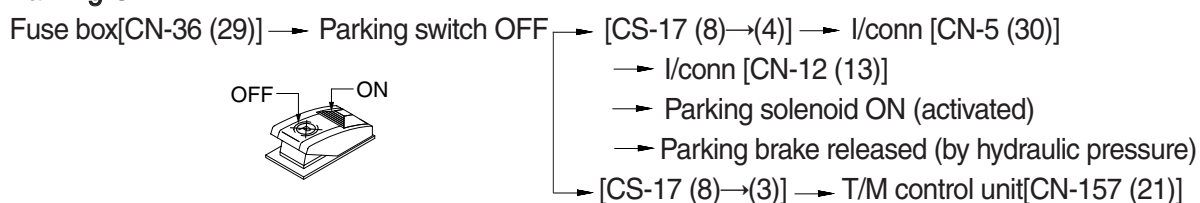

(2) Parking ON

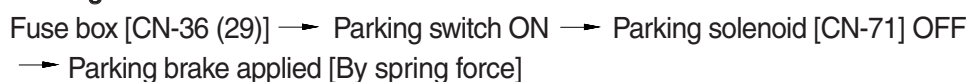

2) CHECK POINT

Engine	Key switch	Check point	Voltage
Running	ON	① - GND (parking switch input) ② - GND (parking switch output) ③ - GND (parking solenoid) ④ - GND (clutch cut off solenoid)	20~25V

※ GND : Ground

ELECTRIC PARKING CIRCUIT

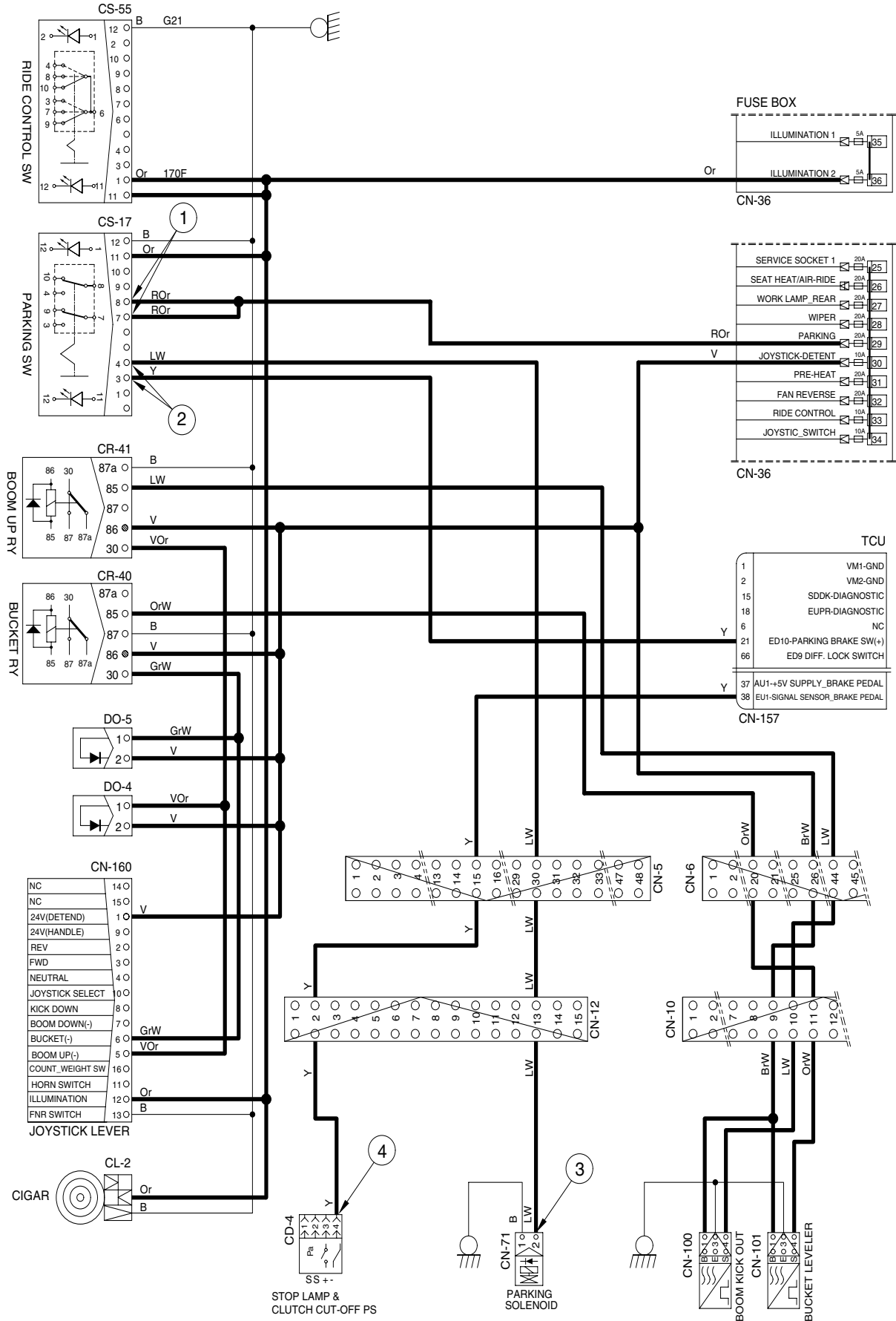

7. WIPER AND WASHER CIRCUIT

1) OPERATING FLOW

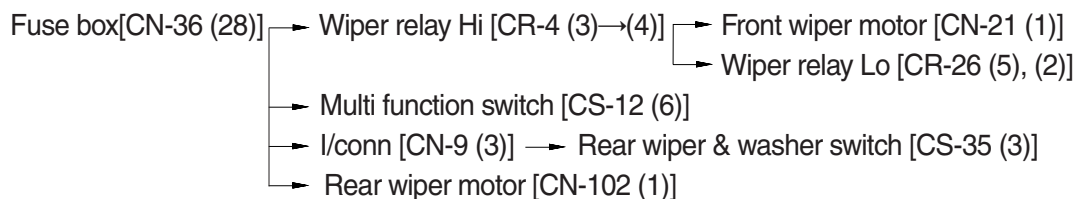

(1) Front washer switch ON

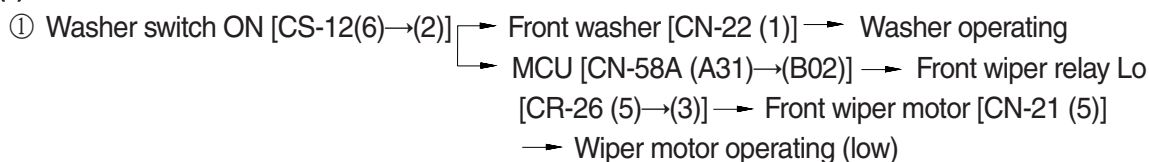

(2) Front wiper switch ON

① INT position

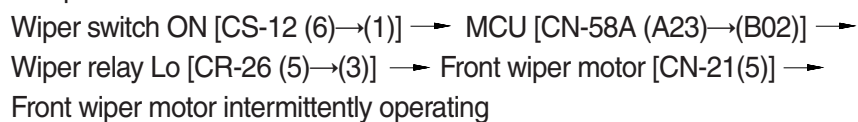

② Lo position

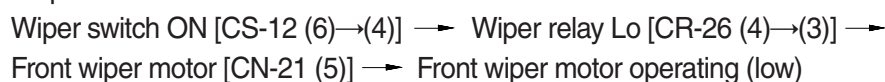

③ Hi position

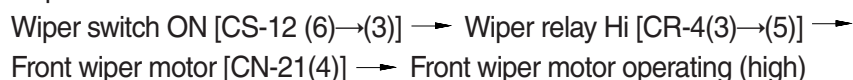

(3) Auto-parking (when switch OFF)

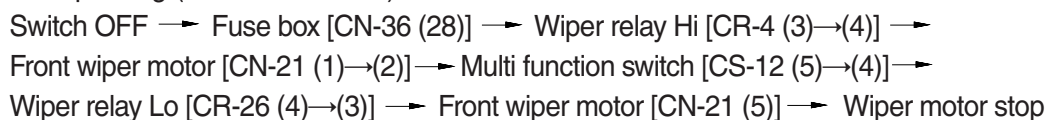

(4) Rear wiper and washer switch

① Wiper switch ON (1st step)

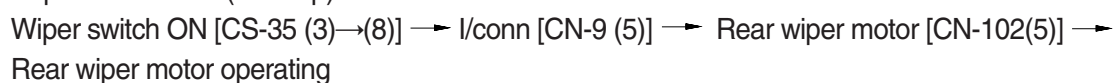

② Washer switch ON (2nd step)



2) CHECK POINT

Condition	Check point	
Engine : Stop	① - GND (front wiper switch power input)	⑥ - GND (wiper relay power input)
	② - GND (rear wiper switch power input)	⑦ - GND (front washer power output)
Key switch : ON	③ - GND (wiper relay power input)	⑧ - GND (rear washer power output)
	④ - GND (front wiper motor Lo power input)	⑨ - GND (front wiper motor power output)
Voltage : 20~25V	⑤ - GND (front wiper motor High power input)	⑩ - GND (rear wiper motor power output)

※ GND : Ground

WIPER AND WASHER CIRCUIT

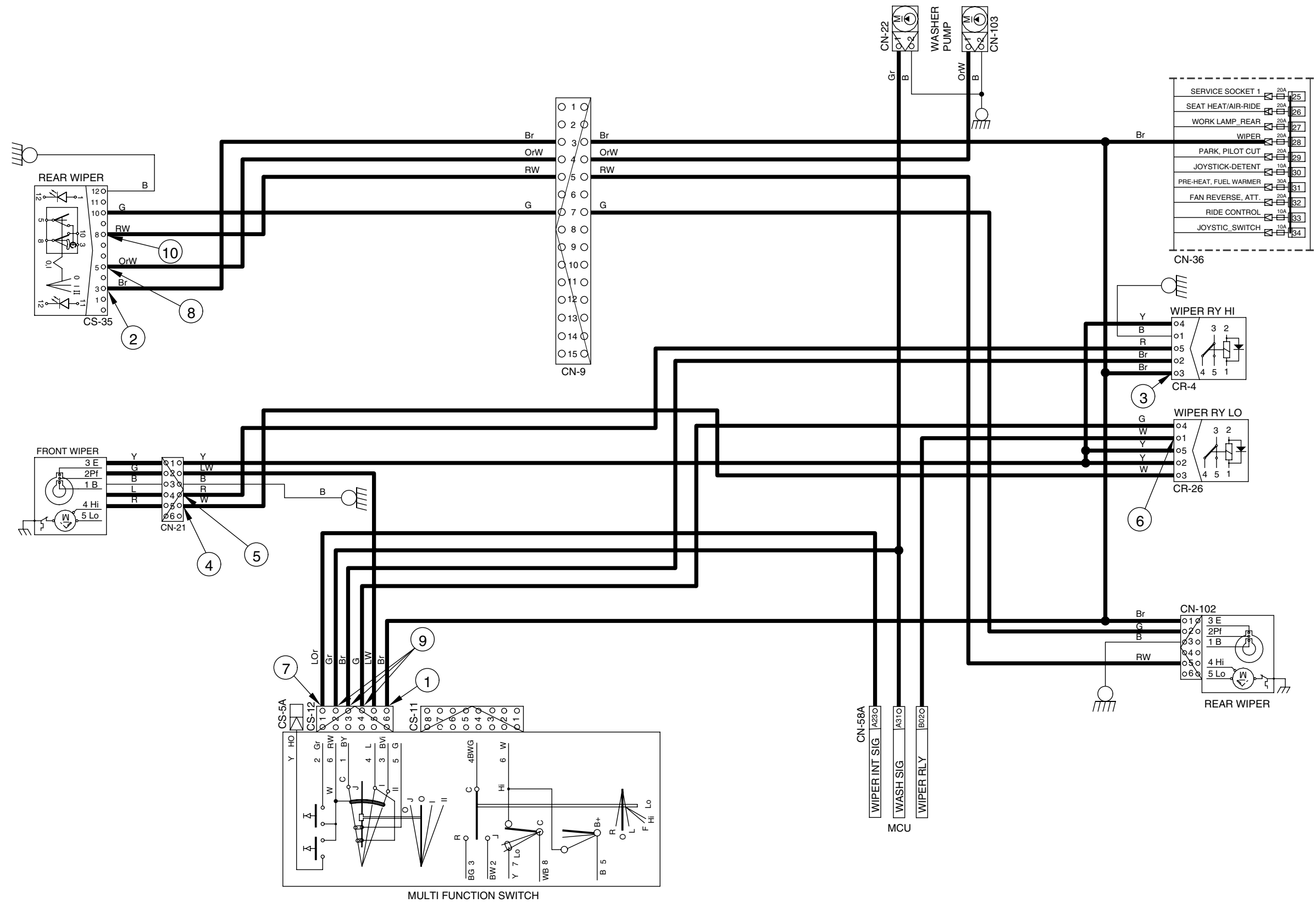

HAZARD, TURN AND ROTARY CIRCUIT

