

GROUP 4 DISASSEMBLY AND ASSEMBLY

1. MAIN PUMP

1) STEERING (1/2)

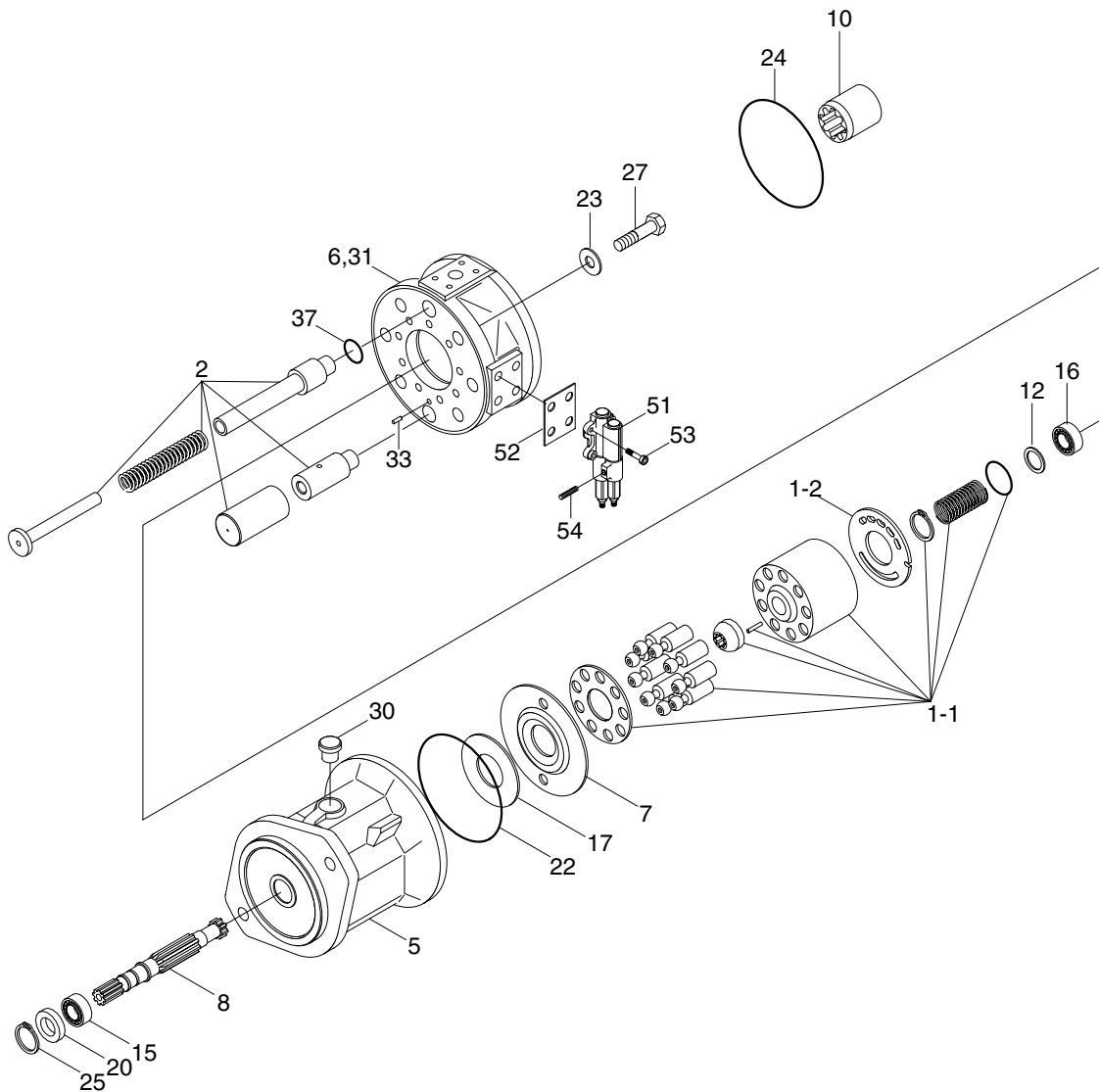

76096WE11

1	Rotary group	12	Adjustment shim	27	Socket screw
1-1	High speed rotary group	15	Taper roller bearing	30	Locking screw
1-2	Control plate	16	Taper roller bearing	31	Double break-off pin
2	Adjusting piece	17	Bearing liner	33	Cylinder pin
5	Pump housing	20	Shaft seal ring	37	Side mark ring
6	Port plate	22	O-ring	51	Control valve
7	Swash plate	23	O-ring	52	Gasket
8	Drive shaft	24	O-ring	53	Socket head screw
10	Splined hub	25	Retaining ring	54	Locking screw

LOADER (2/2)

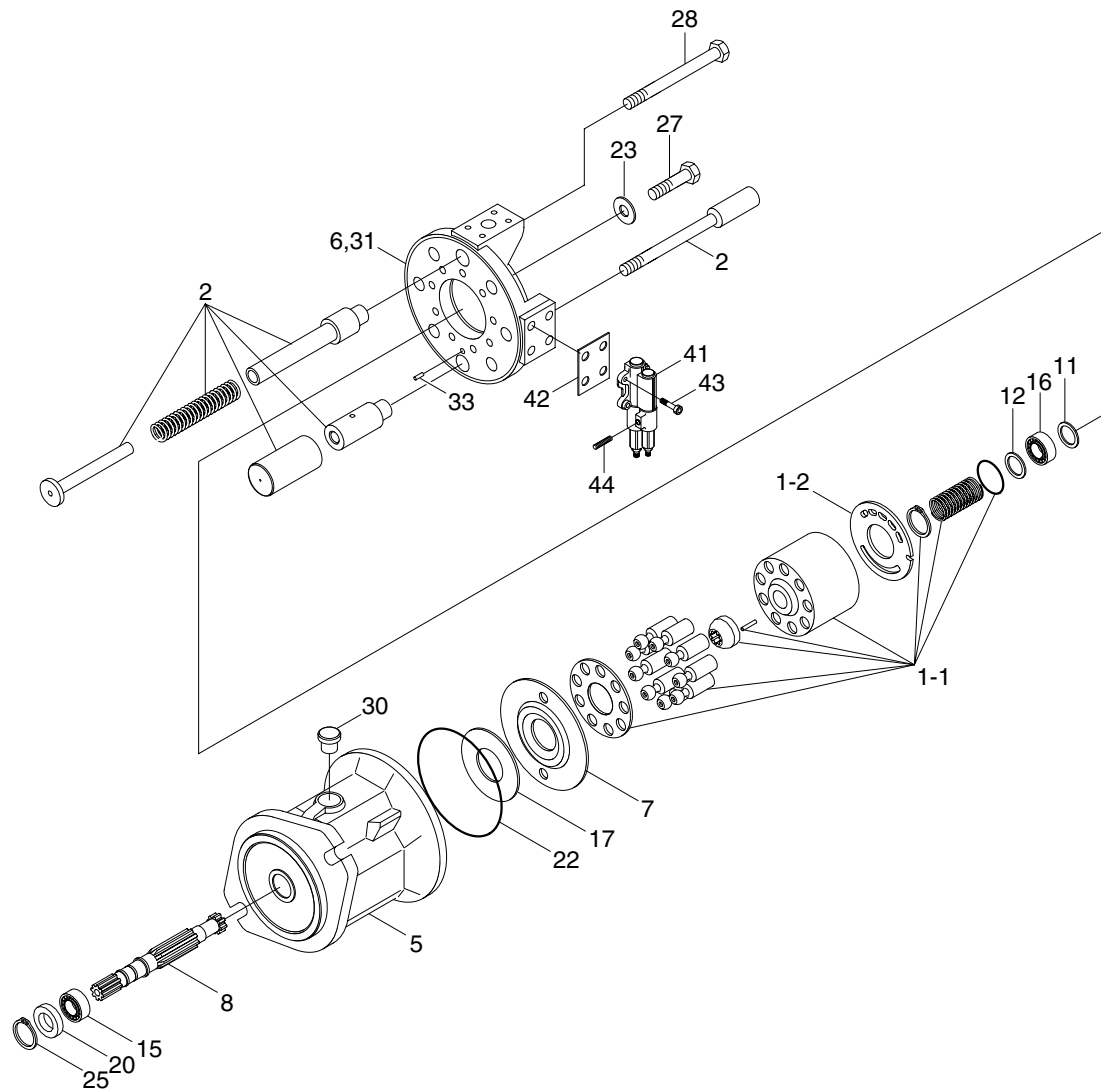

76096WE12

- | | | | | | |
|-----|-------------------------|----|----------------------|----|----------------------|
| 1 | Rotary group | 12 | Adjustment shim | 28 | Locking screw |
| 1-1 | High speed rotary group | 15 | Taper roller bearing | 30 | Locking screw |
| 1-2 | Control plate | 16 | Taper roller bearing | 31 | Double break-off pin |
| 2 | Adjusting piece | 17 | Bearing liner | 33 | Cylinder pin |
| 5 | Pump housing | 18 | Shaft seal ring | 41 | Control valve |
| 6 | Port plate | 22 | O-ring | 42 | Gasket |
| 7 | Swash plate | 23 | O-ring | 43 | Socket screw |
| 8 | Drive shaft | 25 | Retaining ring | 44 | Locking screw |
| 11 | Adjustment shim | 27 | Socket screw | | |

2) GENERAL REPAIR GUIDELINES

- ※ Observe the following guidelines when carrying out repairs on hydraulic pumps.
- (1) Close off all openings of the hydraulic unit.
- (2) Replace all of the seals.
Use only original spare parts.
- (3) Check all sealing and sliding surfaces for wear.
- ※ Re-work of the sliding surfaces by using, for example abrasive paper, can damage the surface.
- (4) Fill the hydraulic pump with hydraulic oil before commissioning.

3) SEALING THE DRIVE SHAFT

- (1) Protect the drive shaft.
Remove the circlip.
Remove the shaft seal.

1 Circlip 2 Shaft seal

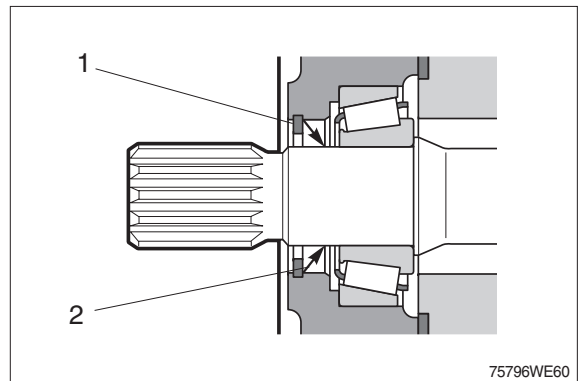

- (2) Change the shaft seal and check its sliding surface (drive shaft) and housing, grease the sealing ring.

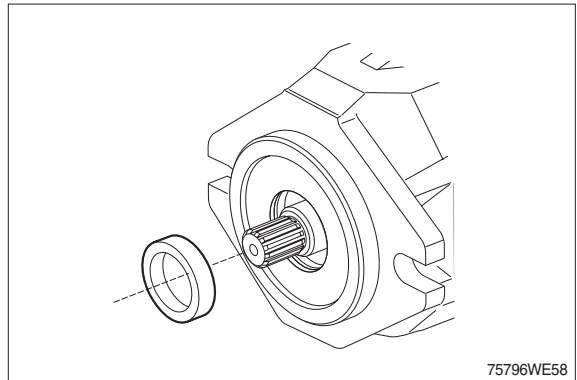

- (3) Assemble the sealing ring, fitting tool holds the correct position of the sealing ring in the pump housing.
Assemble the circlip in the correct position.

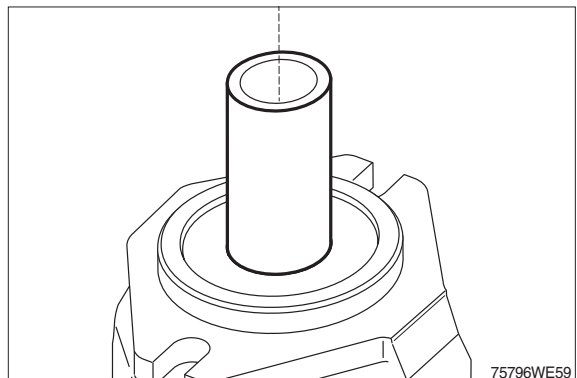

4) SEALING / CLEANING THE CONTROL VALVE

- (1) Disassemble the control valve.
- ※ Measure dimension A and note down.
- Check sealing surface (1).

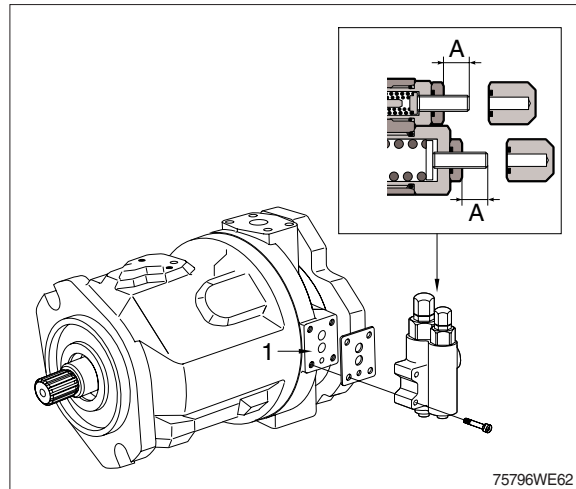

5) DISASSEMBLE THE PUMP

- (1) Remove the control valve.

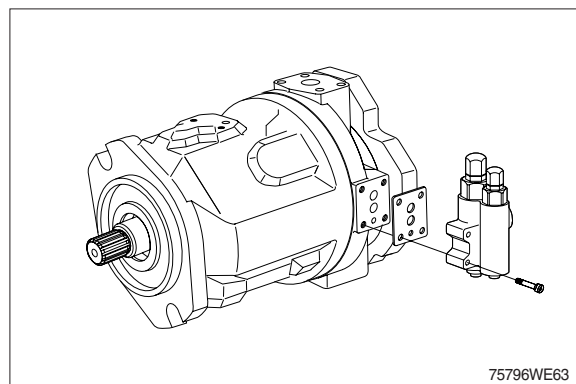

- (2) Mark the location of the connection plate on the housing.

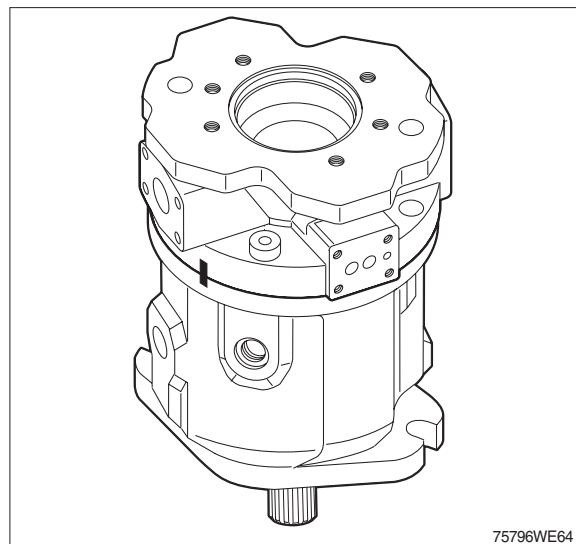

- (3) Remove the connection plate fixing bolts and the connection plate.
※ Distributor plate and adjustment piston can drop down.

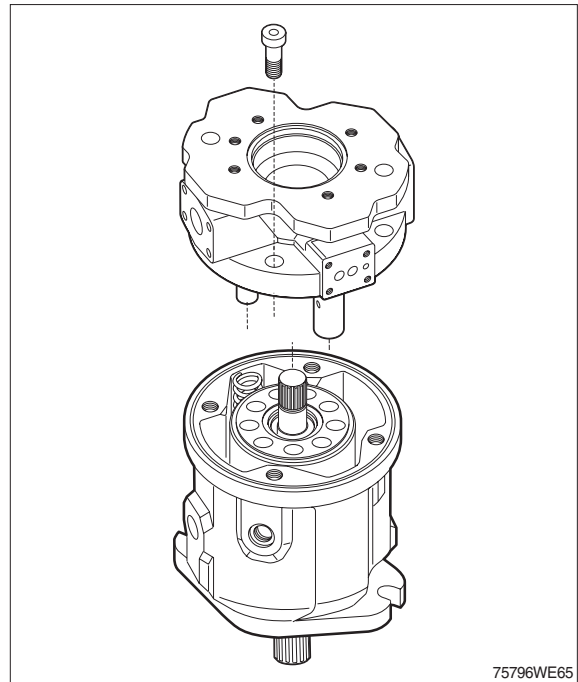

- (4) Remove distributor plate.
Take note of the orientation.
※ Remove bearing with withdrawal tool.
Do not damage the sealing surface.

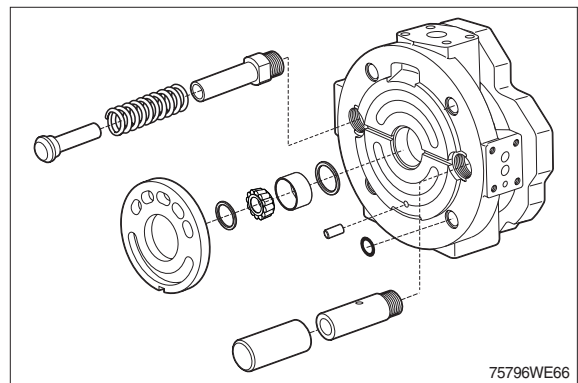

- (5) Remove the rotary group in a horizontal position.

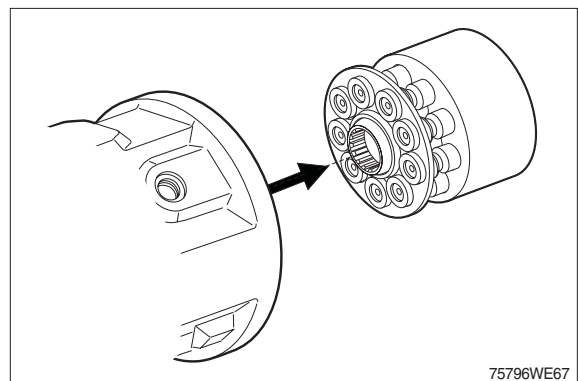

(6) Remove swash plate and bearing shells.

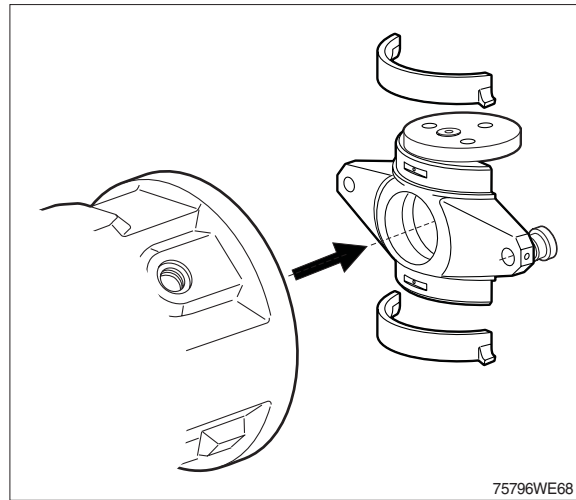

(7) Remove the circlip and the shaft seal.

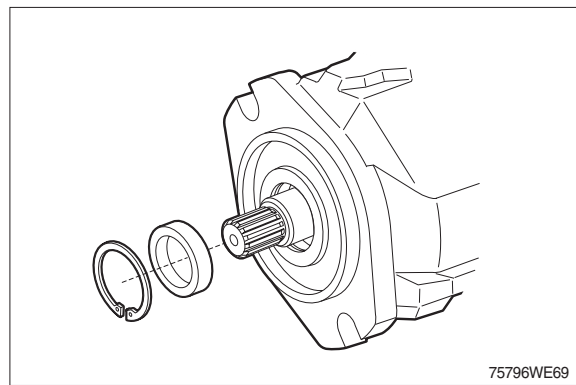

(8) Remove the drive shaft through rear side.

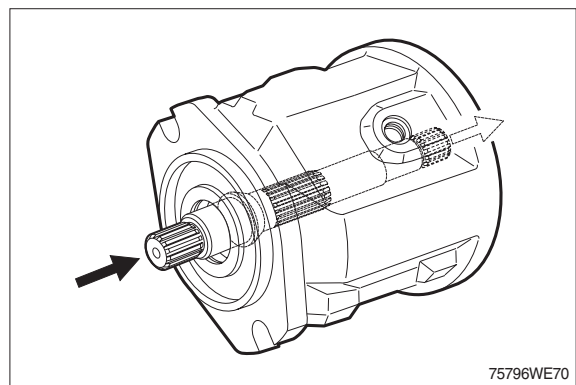

(9) Pre-tension the spring (1) using a suitable device.
Remove circlip (2).
Remove spring (1) and pressure pins (3).

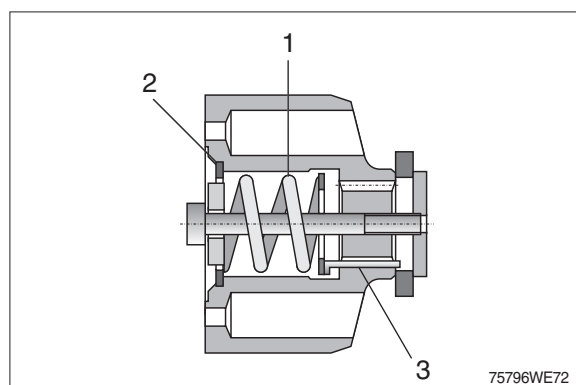

- (10) Use bearing puller to remove outer bearing race of front bearing out of housing press seat.

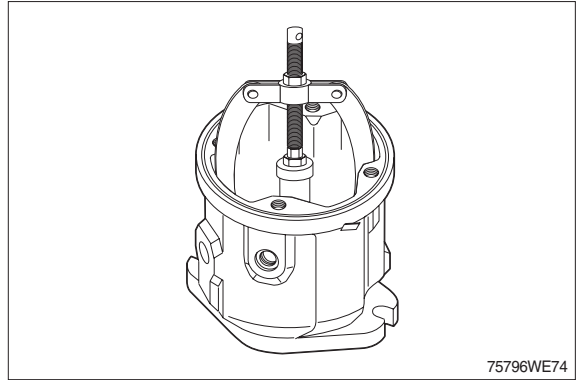

- (11) Remove the control plate.

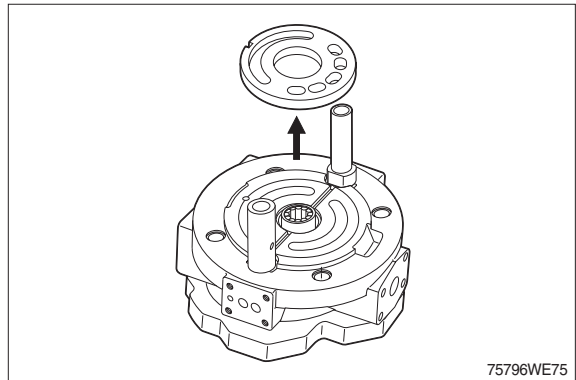

- (12) Use bearing puller to remove outer bearing race of rear bearing - press seat.

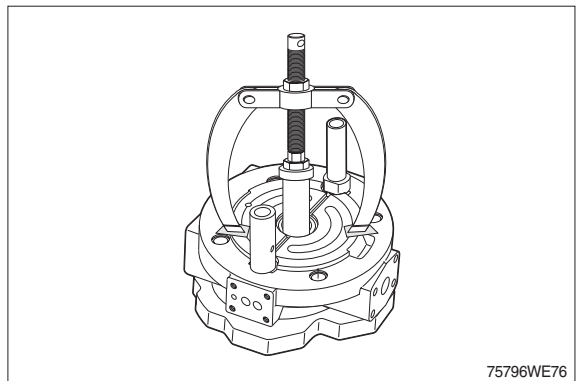

- (13) Disassemble the guide of control piston (Mounting position: pilot valve side).

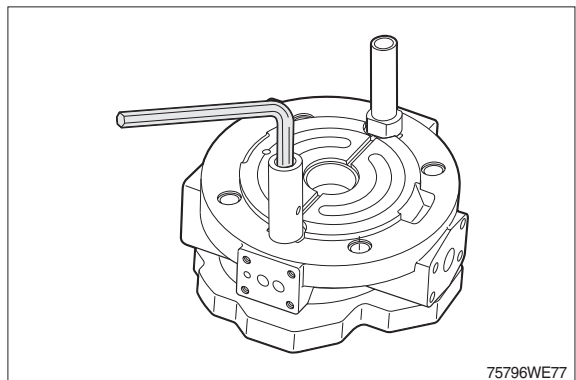

(14) Disassemble the guide of the opposite piston.

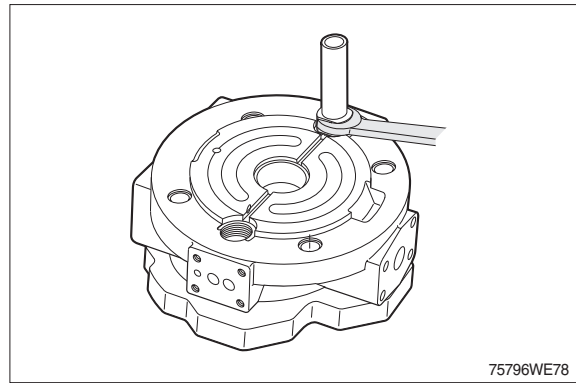

6) INSPECT HINTS

(1) Renew all bearings.

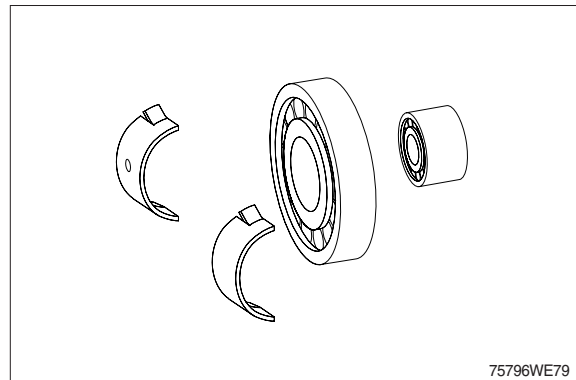

(2) Check :

- 1 Wear on splines, rust
- 2 Drive shaft seal wear grooves
- 3 Bearing seat
- 4 Splines for cylinder drive
- 5 Bearing seat

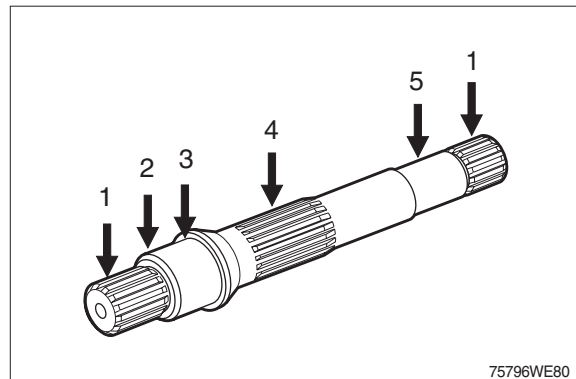

(3) Check :

Sliding surface free of grooves.

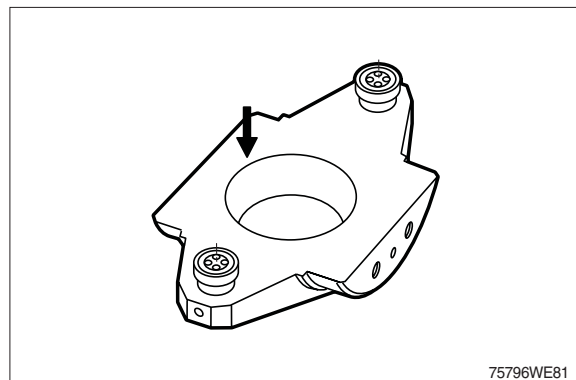

- (4) Check :
Bearing surfaces.

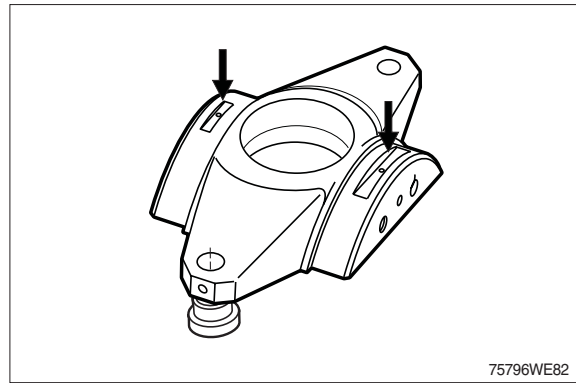

- (5) Check :
That the retaining plate is free of grooves
and that there is no wear in the slipper
pad area.

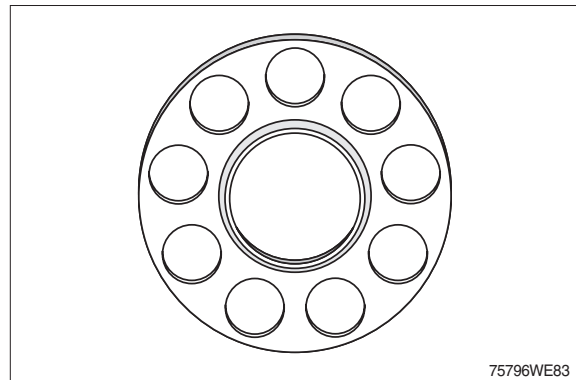

- (6) Check :
Check to see that there are no scratches
or metal deposits on the sliding surface
(1) and that there is no axial play (2)
(Pistons must only be replaced as a set).

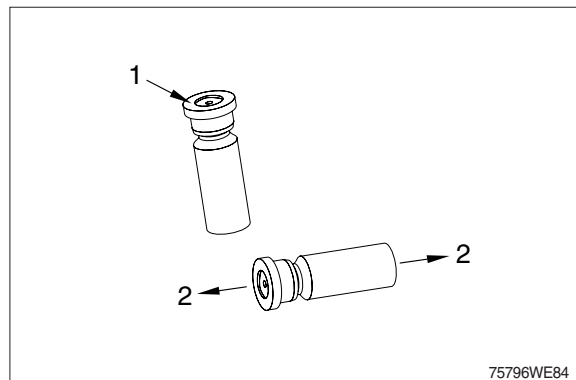

- (7) Check :
1 Cylinder bores
2 Splines

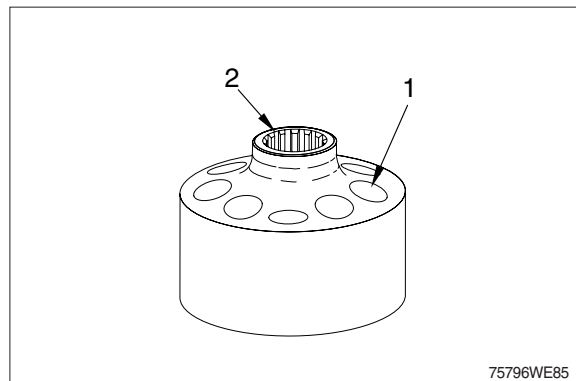

(8) Free of grooves, no signs of wear.

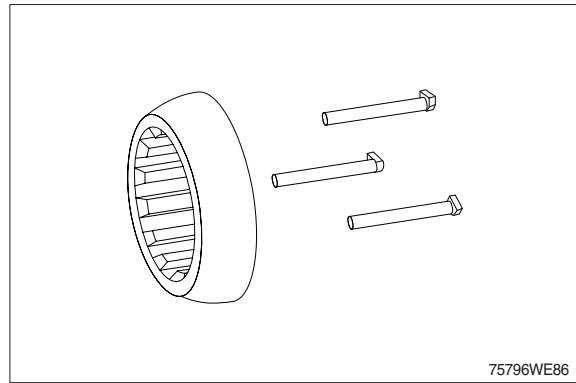

(9) Check :
Cylinder sliding surface free of grooves,
no wear, no embedded foreign particles.
That there are no scratches on the control
plate. (Only replace them as a set).

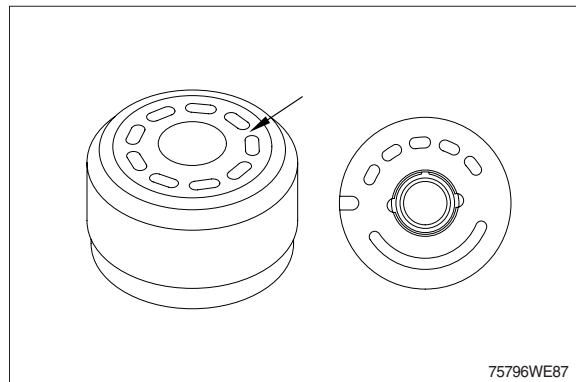

(10) Check :
Mounting surface - control plate
undamaged.

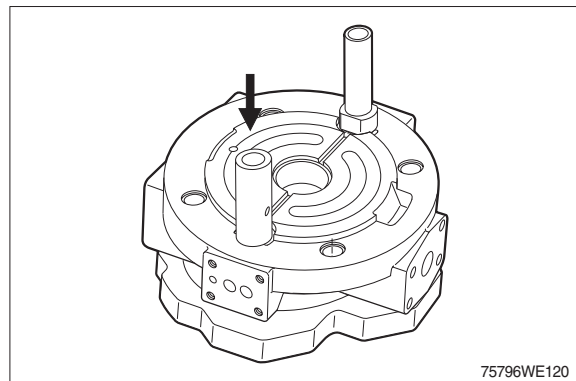

(11) Check :
Check running conditions of the control
piston.

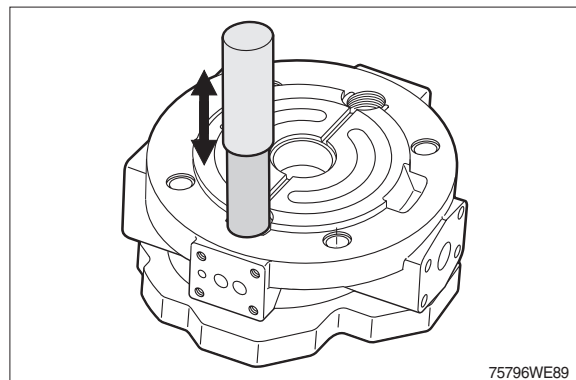

- (12) Check :
 Check running conditions of the opposite piston.

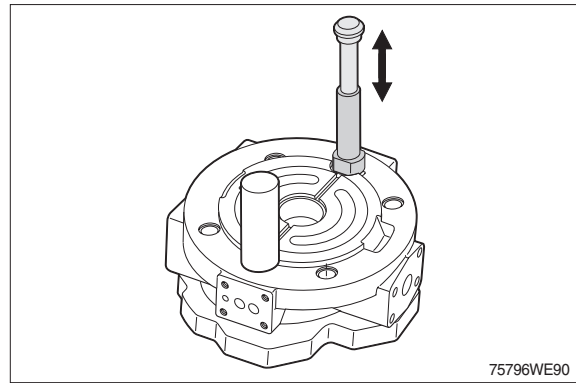

7) ADJUSTMENT OF TAPER ROLLER BEARING SET

- (1) Cast iron housing must have initial tension of the bearings: 0~0,05 mm, grind position A if necessary.

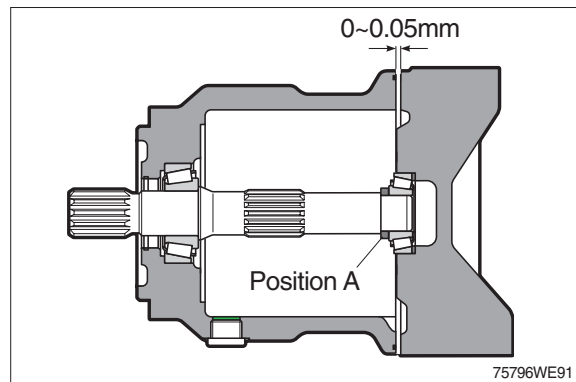

8) PUMP ASSEMBLY

- (1) Fit the seal into the housing.
 Fit the circlip.

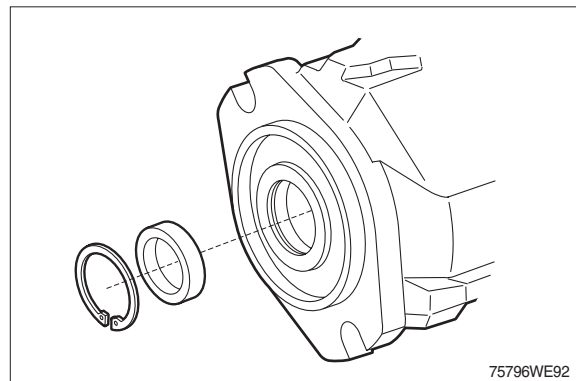

- (2) Fit the drive with bearing from rear end.
 ※ Do not touch seal lip with edge of keyway or spline.

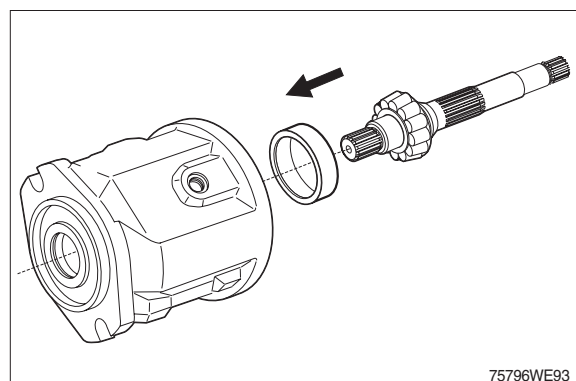

(3) Fit pressure pins using an assembly aid.

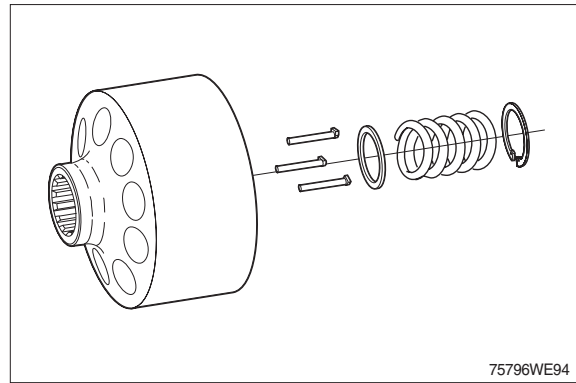

(4) Pre-tension the spring using a suitable device.

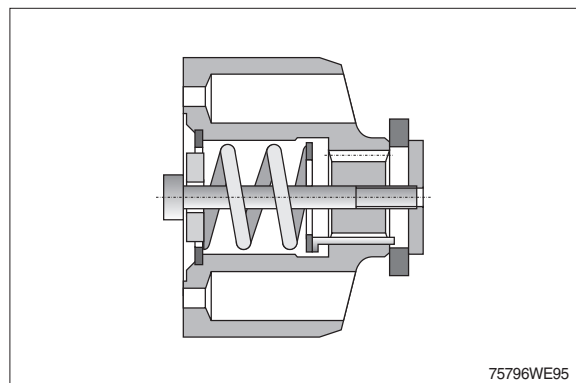

(5) Assemble piston with retaining plate.
※ Oil piston and slipper pad.

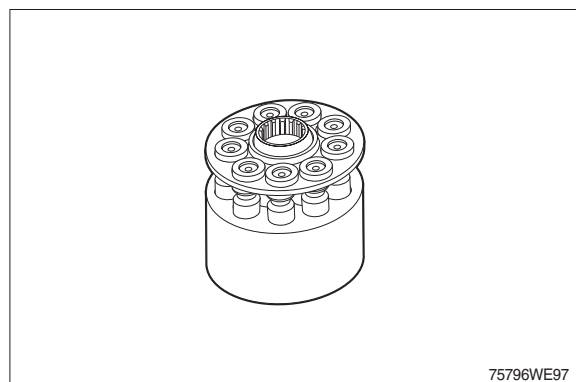

- (6) Fit rotary group.
 ※ Hold the piston by using an O-ring.
 Fit O-ring (1).

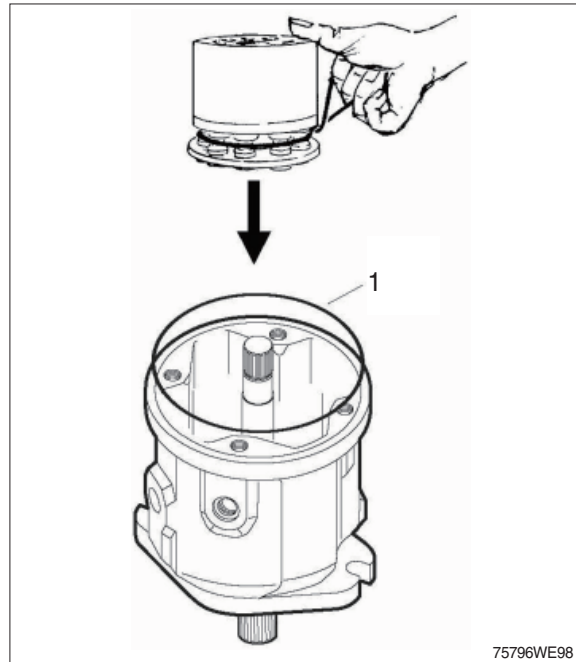

- (7) Fit bearing (1) in connection plate.
 Fit cylindrical pin (2).
 Fit O-rings (3) 4 pieces.
 Fit adjustment spool (4) and guide piston (4a).
 Fit distributor plate (5) (direction of rotation dependent)
 ※ Assembly.
 Hold the components in place with grease.

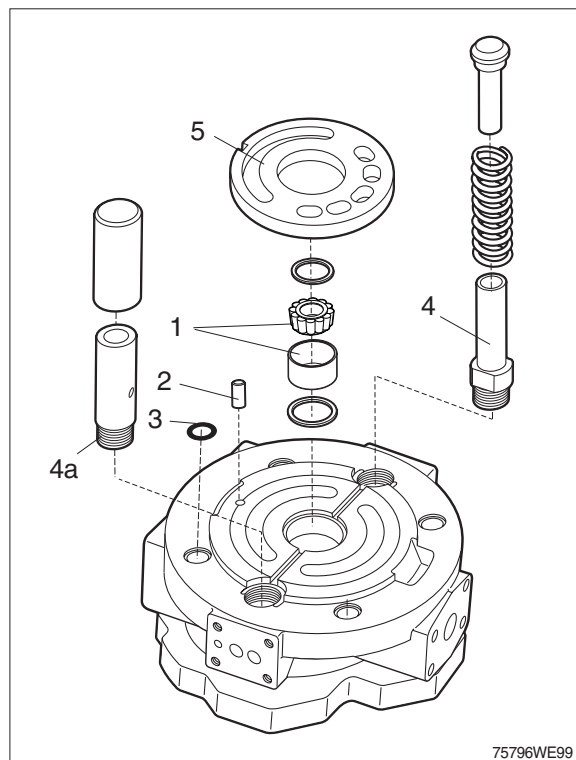

- (8) Fit distributor plate.
※ Assembly aid : Grease

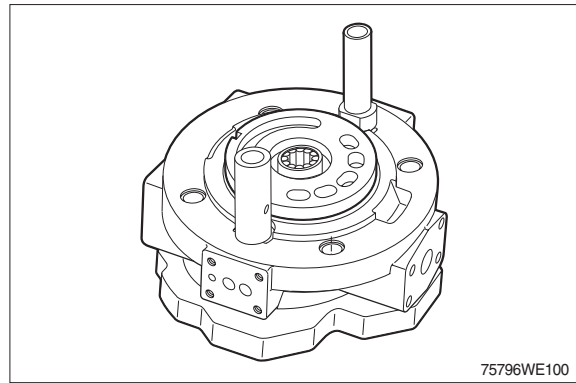

- (9) For clockwise rotation pumps the distributor plate is off-set by 4° to the right from the centre position.
(Clockwise and anti-clockwise rotation distributor plates are not identical).

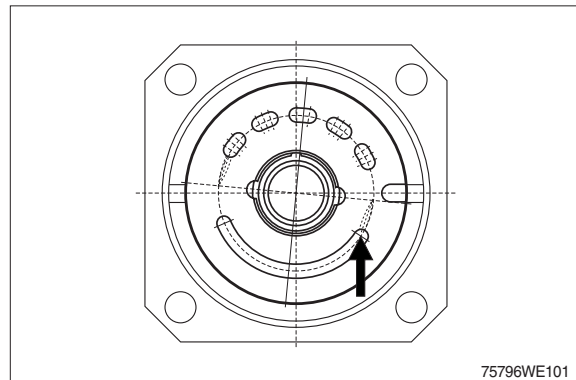

- (10) Fit connection plate and control valve.

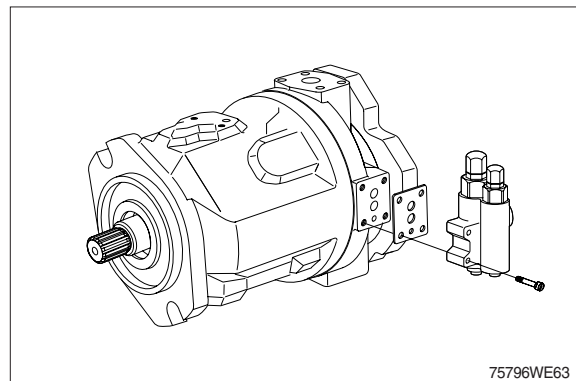

2. MAIN CONTROL VALVE

1) STRUCTURE (1/2)

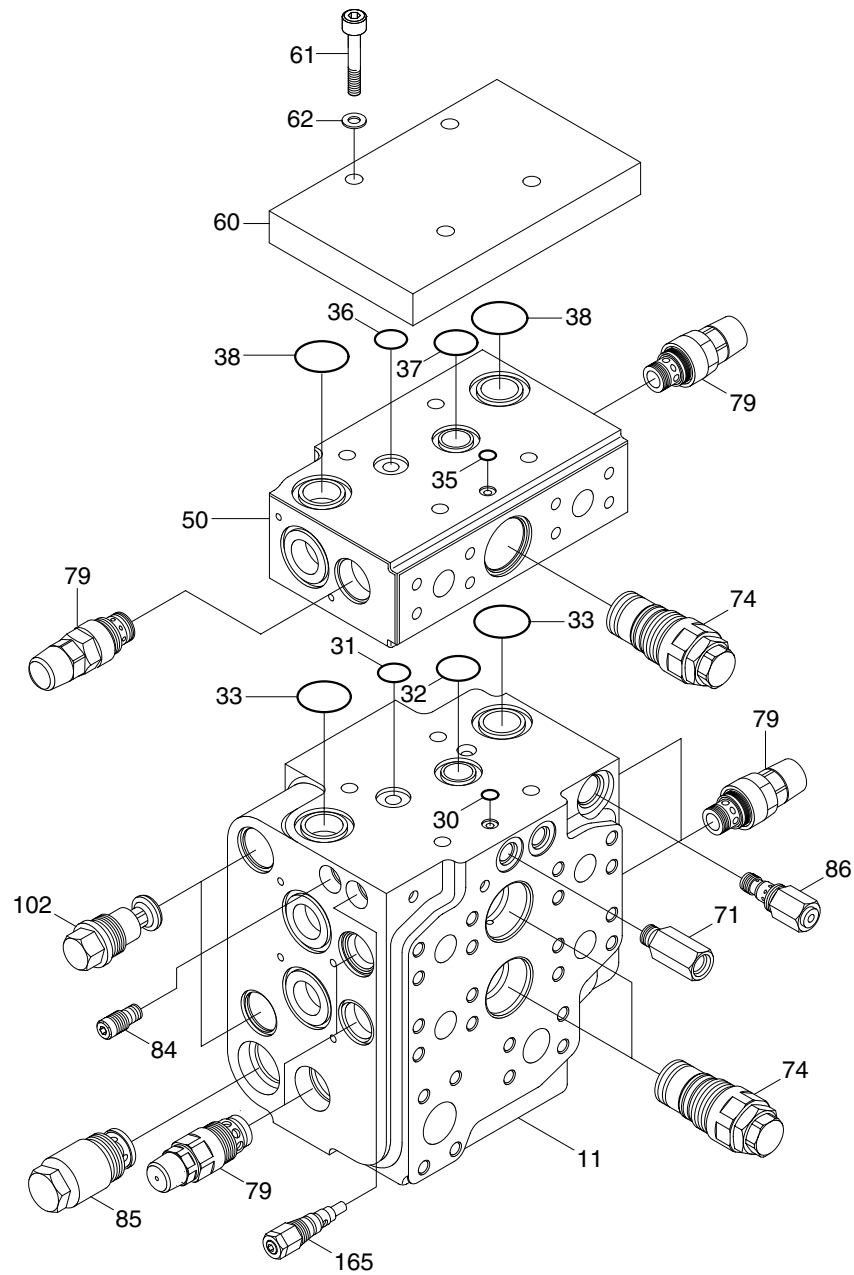

76096WE13

11	Housing	37	O-ring	74	Compensator valve
30	O-ring	38	O-ring	79	Pressure valve
31	O-ring	50	Housing	84	Flow regulator
32	O-ring	60	Plate	85	Precharge valve
33	O-ring	61	Cylinder screw	86	Pilot oil supply
35	O-ring	62	Washer	102	Locking screw
36	O-ring	71	Shuttle valve	165	Pressure relief valve

STRUCTURE (2/2)

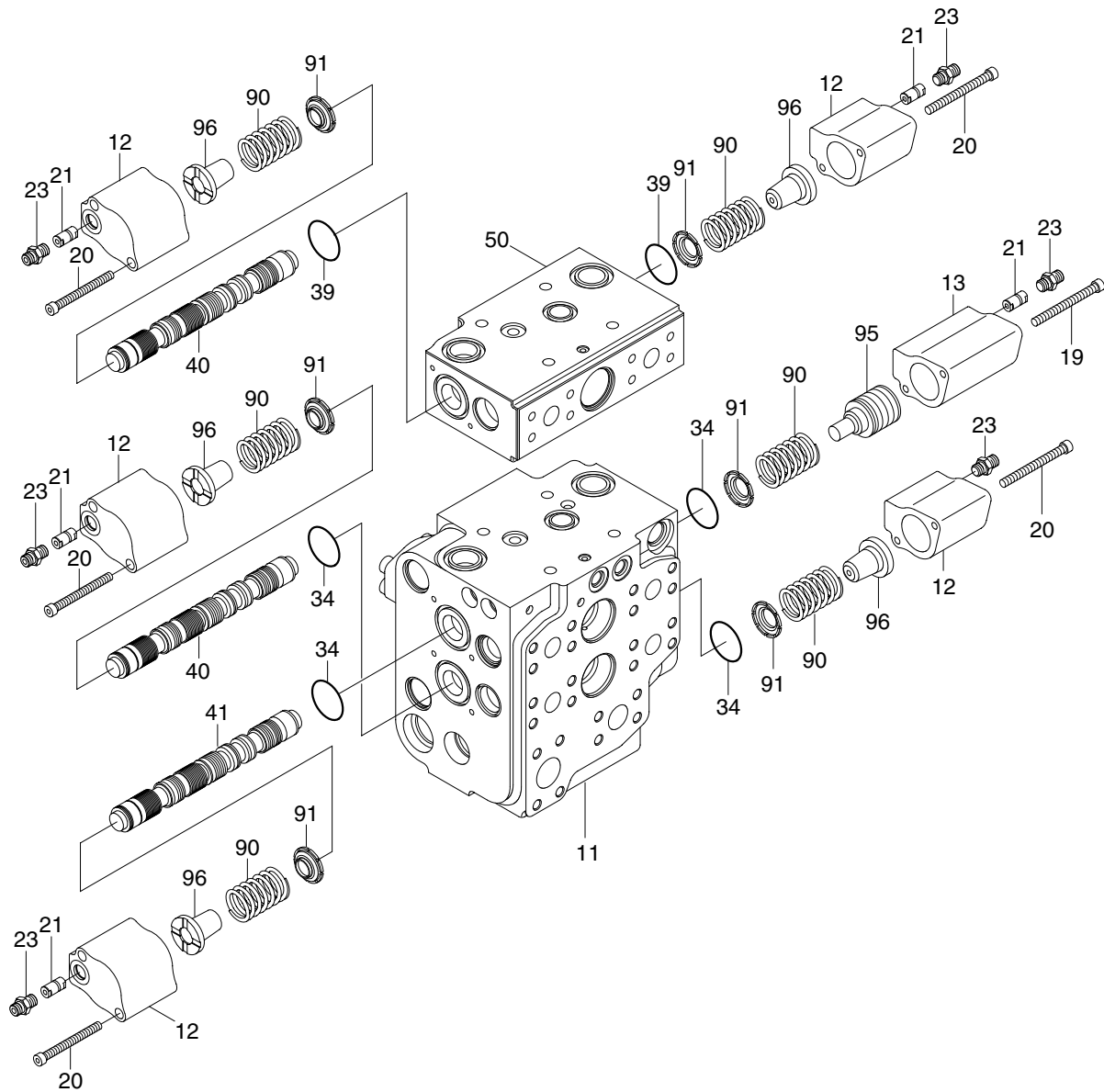

76096WE14

- | | | | | | |
|----|---------|----|-----------------------------|----|--------------------|
| 11 | Housing | 21 | Throttle check valve | 50 | Housing |
| 12 | Cover | 23 | Threaded steel pipe fitting | 90 | Compression spring |
| 13 | Cover | 34 | O-ring | 91 | Spring retainer |
| 14 | Cover | 39 | O-ring | 95 | Spring retainer |
| 19 | Bolt | 40 | Spool | 96 | Spring retainer |
| 20 | Bolt | 41 | Spool | | |

2) GENERAL PRECAUTIONS

- (1) Clean room with no dust is recommended for maintenance. Because hydraulic components are precision, and have minute clearance. Tool and wash-oil must be clean, too. Handle them carefully.
- (2) At removing control valve from the machine, wash around the piping port, and neither dust nor water should go into inside with plugging. It is same at attaching the machine.
- (3) Prepare the required parts by checking structure figure before assembly. There are parts which are supplied with only sub-assembly part, so check the parts list before assembly.

3) PRECAUTIONS FOR DISASSEMBLY

- (1) Handle the components carefully not to drop them or bump them with each other as they are made with precision.
- (2) Do not force the work by hitting or twisting as burred or damaged component may not be assembled or result in oil leakage or low performance.
- (3) When disassembled, tag the components for identification so that they can be reassembled correctly.
- (4) Once disassembled, O-ring and back-up rings are usually not to be used again.(Remove them using a wire with its end made like a shoe-horn. Be careful not to damage the slot)
- (5) If the components are left disassembled or half-disassembled, they may get rust from moisture or dust. If the work has to be interrupted, take care to prevent rust and dust.

4) PRECAUTIONS FOR REASSEMBLY

- (1) Take the same precautions as for disassembly.
- (2) When assembling the components, remove any metal chips or foreign objects and check them for any burrs or dents. Remove burrs and dents with oil-stone, if any.
- (3) O-rings and back-up rings are to be replaced with new ones, as a rule.
- (4) When installing O-rings and back-up rings, be careful not to damage them. (Apply a little amount of grease for smoothness)
- (5) Tighten the bolts and caps with specified torque.

5) DISASSEMBLY AND ASSEMBLY

(1) Spool

- ① Loosen the bolt (2EA).
 - Tool : Wrench 5 mm
 - Tightening torque : 0.85 kgf · m
(6.1 lbf · ft)

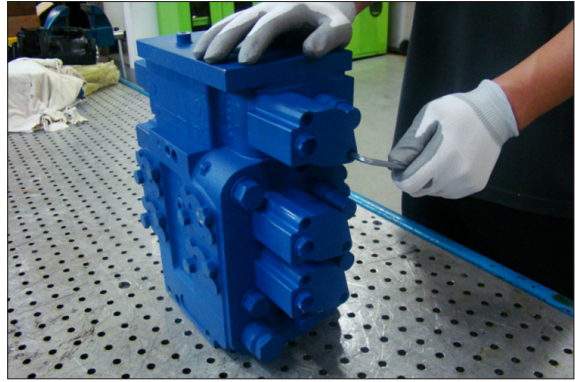

76096WE40

- ② Remove the cover, spring retainer, spring and spool.

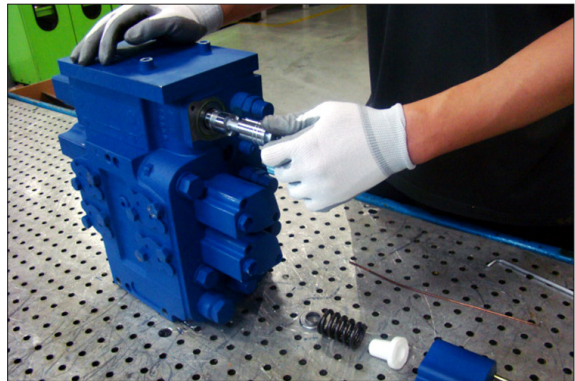

76096WE41

- 1 Spring
- 2 Spring retainer
- 3 Spool
- 4 Cover
- 5 Bolt

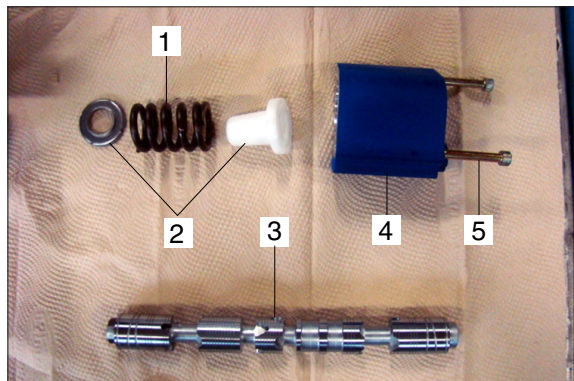

76096WE42

(2) Compensator valve

- Tool : Spanner 42 mm

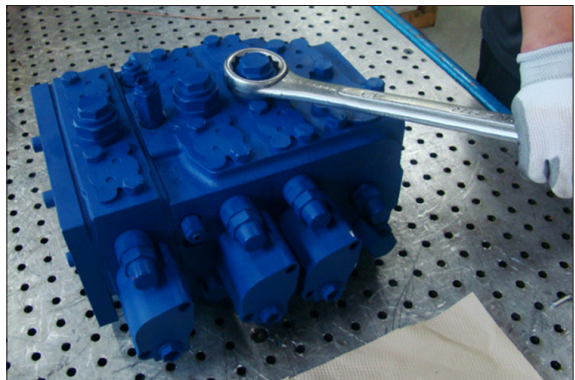

76096WE43

- Tightening torque : 20.4 kgf · m
(148 lbf · ft)

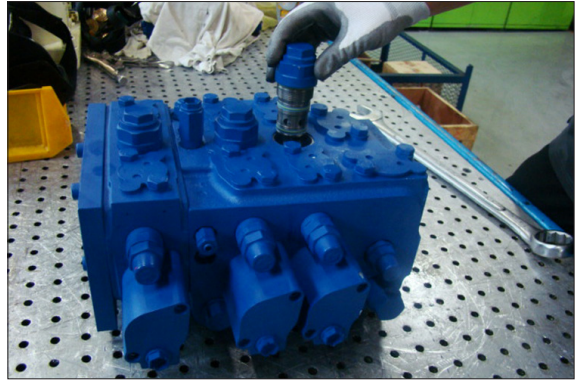

76096WE44

(3) Port relief valve

- Tool : Spanner 30 mm

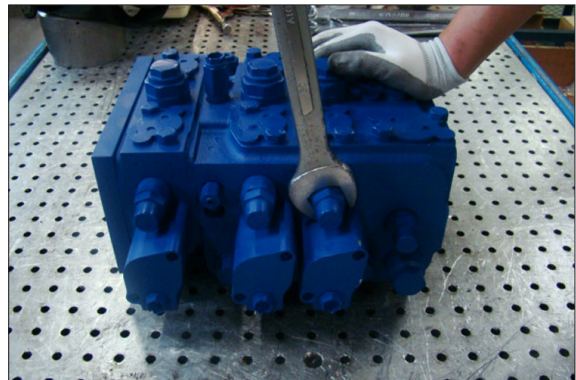

76096WE45

- Tightening torque : 10.2 kgf · m
(73.8 lbf · ft)

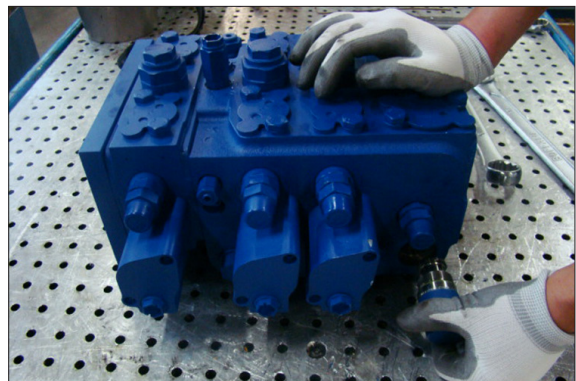

76096WE46

(4) Precharge valve

- Tool : Spanner 32 mm

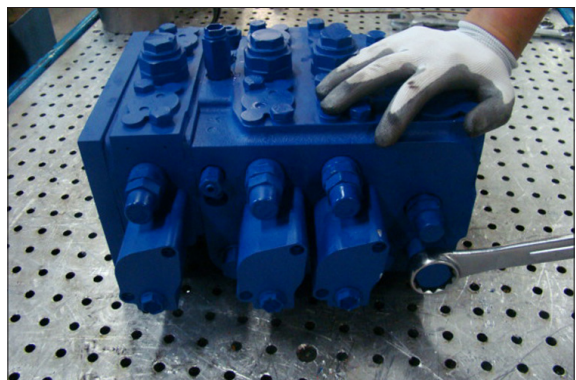

76096WE47

- Tightening torque : 6.1 kgf · m
(44.3 lbf · ft)

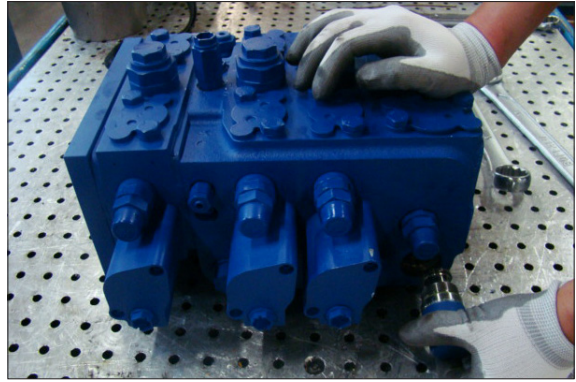

76096WE48

(5) Shuttle valve

- Tool : Spanner 22 mm

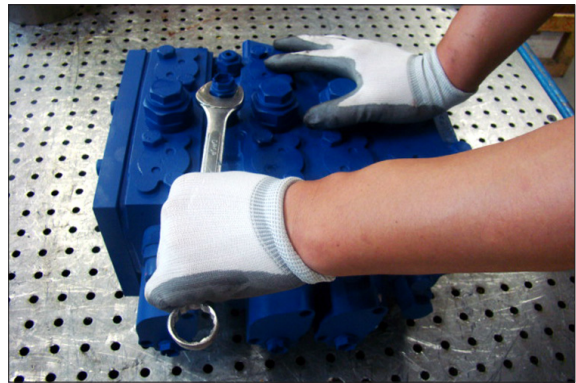

76096WE49

- Tightening torque : 3.6 kgf · m
(25.8 lbf · ft)

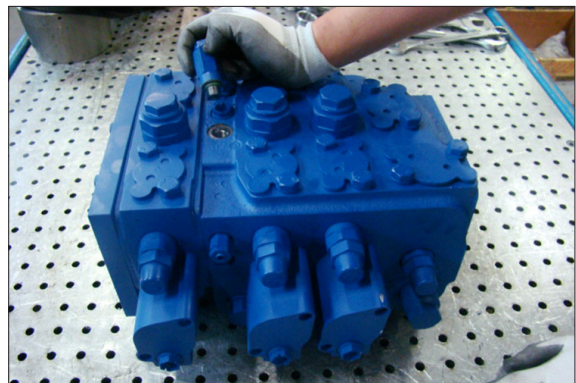

76096WE50

3. REMOTE CONTROL VALVE

1) STRUCTURE

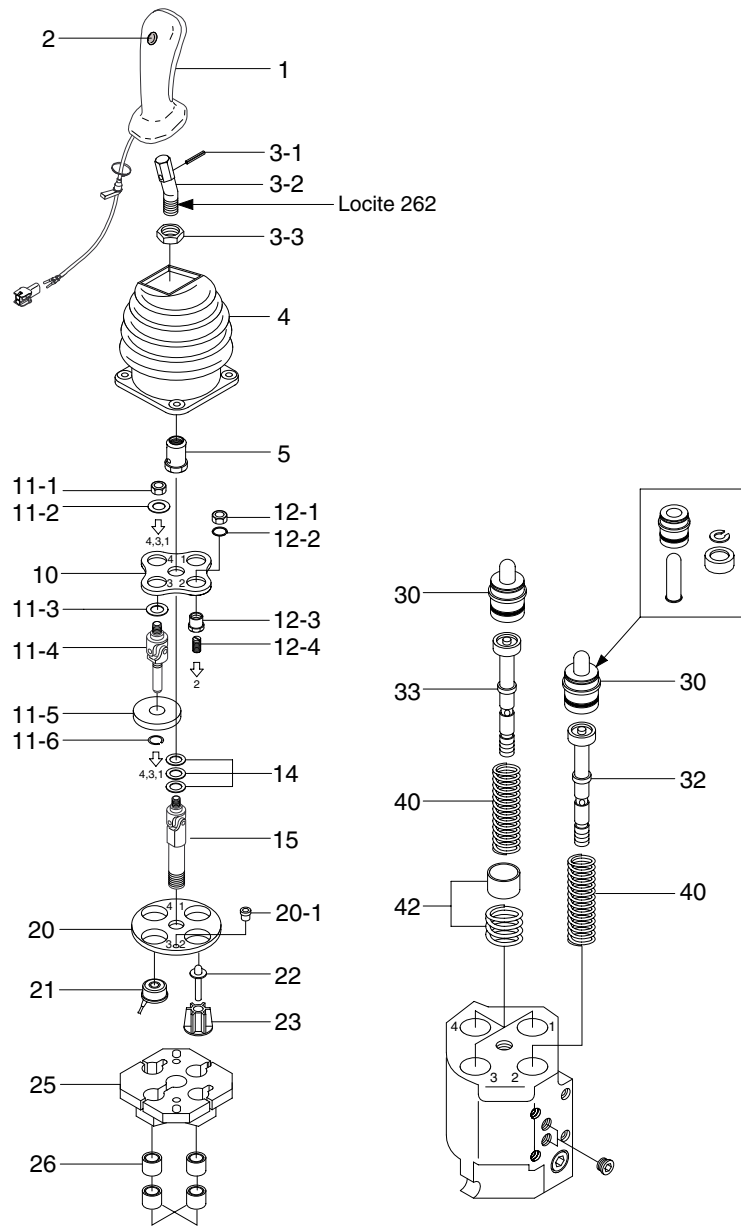

7707WE64

- | | | | | | |
|------|------------------|------|--------------------------|----|----------------------------|
| 1 | Handle | 11-4 | Cardan | 22 | Intermediary plunger kit |
| 2 | Push button | 11-5 | Armature | 23 | Intermediary plunger guide |
| 3-1 | Locking pin | 11-6 | Spring ring | 25 | Electric bracket |
| 3-2 | Bent lever | 12-1 | Counter nut | 26 | Bushing |
| 3-3 | Nut | 12-2 | Spring ring | 30 | Plunger kit |
| 4 | Rubber boot | 12-3 | Switch plate screw | 32 | Regulation unit |
| 5 | Locking nut | 12-4 | Press screw | 33 | Regulation unit |
| 10 | Cardan bracket | 14 | Shims (0.1, 0.2, 0.5 mm) | 40 | Return spring |
| 11-1 | Self-locking nut | 15 | Cardan | 42 | Prefeeling point kit |
| 11-2 | Washer | 20 | Flange | | |
| 11-3 | Washer | 21 | Solenoid | | |

2) DISASSEMBLY AND ASSEMBLY

(1) PUSH BUTTON

- ※ The remote control valve does not need to be removed from the machine to perform this operation.

Remove worn pushbutton using a small screwdriver.

The installation of new elements is performed without any special tools; the parts are simply pressed into place.

(2) RUBBER BOOT

- ① Remove the remote control valve from the machine or free the valve by unscrewing the 4 screws fixing the plate in order to release the electrical cable.

- Assembly

Torque : 1.02 kgf · m (7.4 lbf · ft)

Hold the remote control valve using a vice or a vice-grip wrench (clamp onto the body).

- ※ The pilot unit does not need to be removed from the machine to release the cable. However, it is recommended to lift the control unit by undoing the 4 fixing screws on the arm rest.
- ※ It is unnecessary to remove the units with no electrical functions.

- ② Lift and turn the boot inside out.

- ③ Remove the grommet (7) from its emplacement to free the cable.

- ④ Loosen the handle mounting nut (3-3) using a 19 mm open-end wrench.

- Assembly : torque 4.08 kgf · m (29.5 lbf · ft)

- ⑤ Unscrew and remove the handle (1).

- Assembly

- Add loctite 262 onto the lever thread

- Torque : 4.08 kgf · m (29.5 lbf · ft)

- ⑥ Replace the faulty rubber boot (4) with a new one.

- ⑦ Replace the handle (1) following the disassembly instructions in reverse order.

(3) HANDLE

- ① Clamp the threaded section of the lever (3-2) in a vice fitted with V-shaped vice clamp.

- ② Remove the pin (3-1) using a 5mm pin driver.

- ③ Replace the lever (3-2) onto the new handle (1) and secure it with the pin (3-1) using a 5mm pin driver.

- ※ Respect the position of the curved lever to ensure that the handle is correctly oriented as indicated by the machine's technical specifications.

- ④ Replace the nut (3-3) on the threaded section and replace the boot (4).

(4) DETENT CARDAN BRACKET KIT

- ※ Remove the 2 grommets (20-1) from the flange (20).
- ※ Place centering sleeves V & W to avoid damaging the cardan knuckles while loosening the nuts.
- ※ Unscrew the locking nut (5) using a 23mm open-end wrench.
 - Assembly : Torque 4.08 ± 0.4 kgf · m
(29.5 ± 2.9 lbf · ft)

- ① Unscrew the self-locking nut (11-1) using a 13mm open-end wrench.
 - Assembly
 - Torque 1.02 kgf · m (7.4 lbf · ft)
 - Place centering sleeves (V-W) to avoid damaging the cardan knuckles while screwing the nuts.
- ② Remove : - Friction washer (11-2)
 - Friction washer (11-3)
 - Cardan/armature assembly (11-4 ~ 11-6)

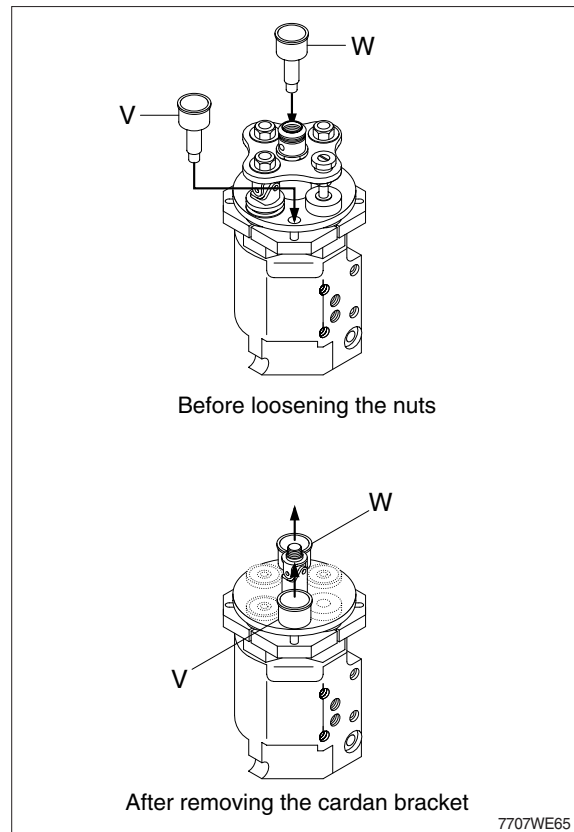

(5) NON-DETENT PLUNGER KIT

- ① Unscrew the self-locking nut (12-1) using a 13 mm open-end wrench.
 - Reassembly : - Torque 1.02 kgf · m (7.4 lbf · ft)
 - Place centering sleeves (V-W) to avoid damaging the cardan knuckles while screwing the nuts.
- ② Undo the snap ring (12-2) using a flat-end screwdriver.
- ③ Remove the screw assembly (12-3, 12-4)

(6) CARDAN

- ① Remove the centering sleeves V & W.
- ② Remove the cardan bracket (10) and the shims (14).
- ③ Unscrew the cardan (15) using a 17 mm open-end wrench.
 - Reassembly : - Ungrease the cardan threads
 - Add loctite 262 onto the cardan threads (both end)
 - Torque 4.08 kgf · m (29.5lbf · ft)

(7) SOLENOID AND CONNECTOR

- ※ It is advised to mount the connector onto the solenoid cable once the remote control valve is assembled.
- ① Remove the flange (20) and the electrical bracket (25),
 - ② Remove the protecting bushes (26) from the electrical bracket (25).
 - ③ Undo the solenoid (21) from the electric bracket (25).
 - ④ Replace the solenoid.
 - ※ Clean the polar face using a piece of cloth and pay attention not to hit them.
 - ⑤ Assembly : Place the solenoid cable in its emplacement on the electric bracket before fitting the protection bushes.

(8) INTERMEDIARY PLUNGER KIT

- ① Undo the intermediary plunger guide (23).
- ② Remove and replace the intermediary plunger kit assembly (22).

(9) GUIDE / PLUNGER AND REGULATION UNIT

※ Beware of the plungers that might jump out due to the spring return.

- ① Remove : - Guide/plunger assembly (30).
 - Regulation unit (32/33).
 - Return spring (40).
 - Pre-feeling point kit (42).
- ② The remote control valve is now totally disassembled.
Assemble in reverse order following the torque specification.