

GROUP 2 SPECIFICATION

1. MAJOR COMPONENT

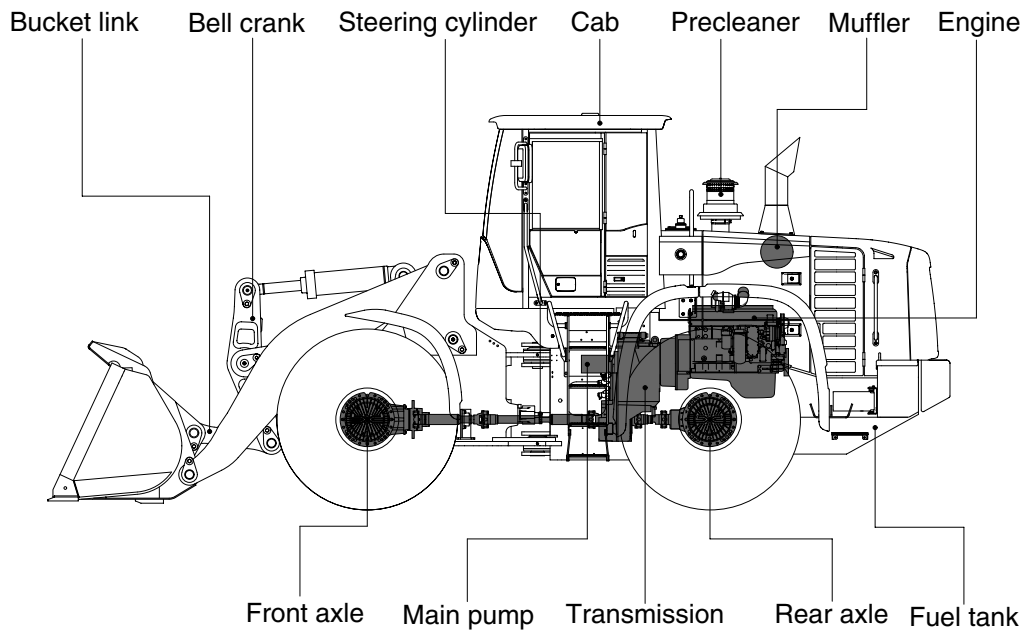
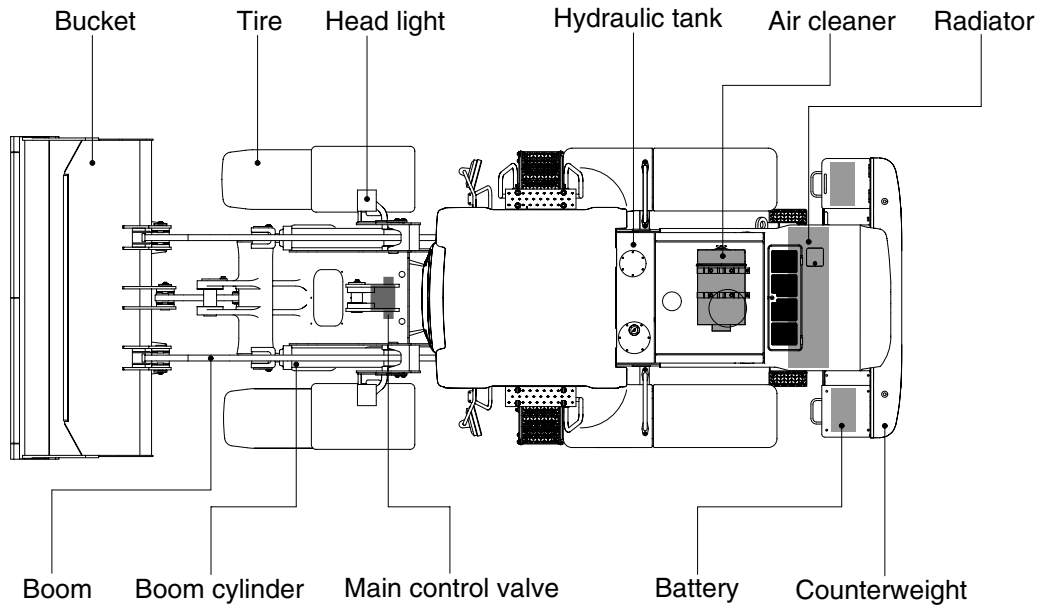

77092SE01

2. SPECIFICATIONS

1) WITH BOLT-ON CUTTING EDGE TYPE BUCKET (HL770-9)

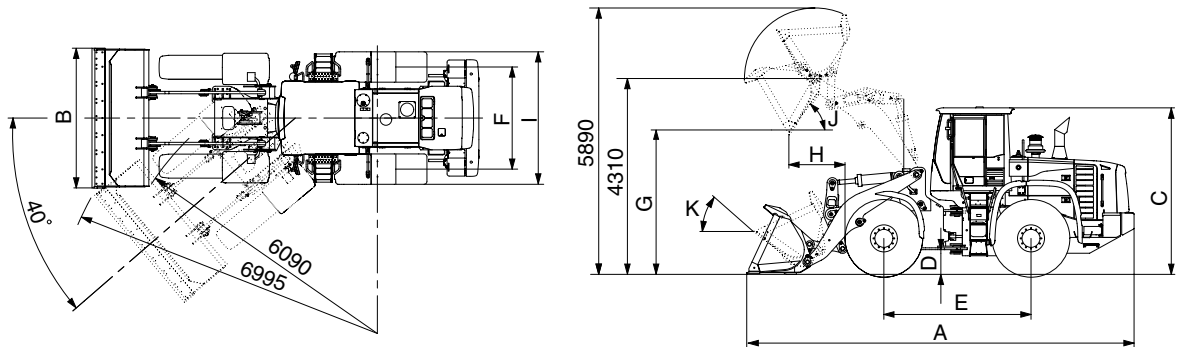

77092SE03

Description		Unit	Specification	
Operating weight		kg (lb)	23100 (50930)	
Bucket capacity	Struck	m ³ (yd ³)	3.6 (4.7)	
	Heaped		4.2 (5.5)	
Overall length	A	mm (ft-in)	8700 (28' 7")	
Overall width	B		3100 (10' 2")	
Overall height	C		3560 (11' 8")	
Ground clearance	D		480 (1' 7")	
Wheelbase	E		3500 (11' 6")	
Tread	F		2300 (7' 7")	
Dump clearance at 45°	G		3090 (10' 2")	
Dump reach (full lift)	H		1295 (4' 3")	
Width over tires	I		2975 (9' 9")	
Dump angle	J		degree (°)	48
Roll back angle (carry position)	K			49
Cycle time	Lift (with load)	sec	5.4	
	Dump (with load)		1.3	
	Lower (empty)		2.8	
Maximum travel speed		km/hr (mph)	41.0 (25.5)	
Braking distance		m (ft-in)	12 (39' 4")	
Minimum turning radius (center of outside tire)			6.09 (20' 0")	
Gradeability		degree (°)	30	
Travel speed	Forward	First gear	6.9 (4.3)	
		Second gear	12.3 (7.7)	
		Third gear	26.9 (16.8)	
		Fourth gear	41.0 (25.5)	
	Reverse	First gear	6.9 (4.3)	
		Second gear	12.3 (7.7)	
Third gear		26.9 (16.8)		

WITH BOLT-ON CUTTING EDGE TYPE BUCKET (HL770XTD-9)

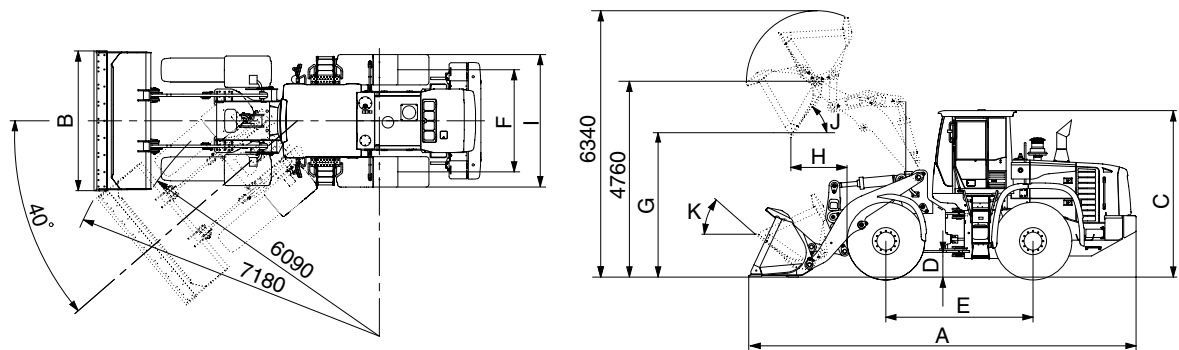

77092SE03-1

Description		Unit	Specification	
Operating weight		kg (lb)	23850 (52580)	
Bucket capacity	Struck	m ³ (yd ³)	3.6 (4.7)	
	Heaped		4.2 (5.5)	
Overall length	A	mm (ft-in)	9175 (30' 1")	
Overall width	B		3100 (10' 2")	
Overall height	C		3560 (11' 8")	
Ground clearance	D		480 (1' 7")	
Wheelbase	E		3500 (11' 6")	
Tread	F		2300 (7' 7")	
Dump clearance at 45°	G		3540 (11' 7")	
Dump reach (full lift)	H		1295 (4' 3")	
Width over tires	I		2975 (9' 9")	
Dump angle	J		degree (°)	48
Roll back angle (carry position)	K			50
Cycle time	Lift (with load)	sec	5.4	
	Dump (with load)		1.3	
	Lower (empty)		2.8	
Maximum travel speed		km/hr (mph)	41.0 (25.5)	
Braking distance		m (ft-in)	12 (39' 4")	
Minimum turning radius (center of outside tire)			6.09 (20' 0")	
Gradeability		degree (°)	30	
Travel speed	Forward	First gear	6.9 (4.3)	
		Second gear	12.3 (7.7)	
		Third gear	26.9 (16.8)	
		Fourth gear	41.0 (25.5)	
	Reverse	First gear	6.9 (4.3)	
		Second gear	12.3 (7.7)	
Third gear		26.9 (16.8)		

2) WITH TOOTH TYPE BUCKET (HL770-9)

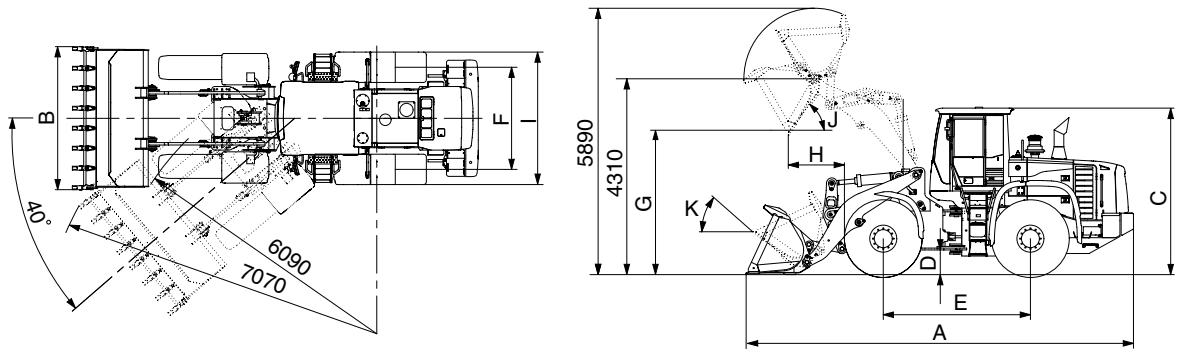

77092SE04

Description		Unit	Specification	
Operating weight		kg (lb)	23100 (50930)	
Bucket capacity	Struck	m ³ (yd ³)	3.4 (4.4)	
	Heaped		4.0 (5.2)	
Overall length	A	mm (ft-in)	8820 (28' 11")	
Overall width	B		3150 (10' 4")	
Overall height	C		3560 (11' 8")	
Ground clearance	D		480 (1' 7")	
Wheelbase	E		3500 (11' 6")	
Tread	F		2300 (7' 7")	
Dump clearance at 45°	G		2965 (9' 9")	
Dump reach (full lift)	H		1380 (4' 6")	
Width over tires	I		2975 (9' 9")	
Dump angle	J		degree (°)	48
Roll back angle (carry position)	K			49
Cycle time	Lift (with load)	sec	5.4	
	Dump (with load)		1.3	
	Lower (empty)		2.8	
Maximum travel speed		km/hr (mph)	41.0 (25.5)	
Braking distance		m (ft-in)	12 (39' 4")	
Minimum turning radius (center of outside tire)			6.09 (20' 0")	
Gradeability		degree (°)	30	
Travel speed	Forward	First gear	6.9 (4.3)	
		Second gear	12.3 (7.7)	
		Third gear	26.9 (16.8)	
		Fourth gear	41.0 (25.5)	
	Reverse	First gear	6.9 (4.3)	
		Second gear	12.3 (7.7)	
Third gear		26.9 (16.8)		

WITH TOOTH TYPE BUCKET (HL770XTD-9)

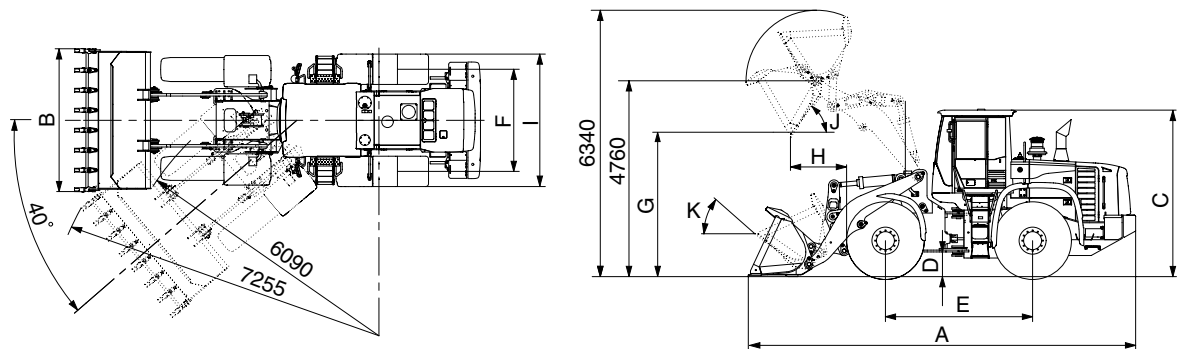

77092SE04-1

Description		Unit	Specification	
Operating weight		kg (lb)	23850 (52580)	
Bucket capacity	Struck	m ³ (yd ³)	3.4 (4.4)	
	Heaped		4.0 (5.2)	
Overall length	A	mm (ft-in)	9320 (30' 7")	
Overall width	B		3150 (10' 4")	
Overall height	C		3560 (11' 8")	
Ground clearance	D		480 (1' 7")	
Wheelbase	E		3500 (11' 6")	
Tread	F		2300 (7' 7")	
Dump clearance at 45°	G		3415 (11' 2")	
Dump reach (full lift)	H		1380 (4' 6")	
Width over tires	I		2975 (9' 9")	
Dump angle	J		degree (°)	48
Roll back angle (carry position)	K			50
Cycle time	Lift (with load)	sec	5.4	
	Dump (with load)		1.3	
	Lower (empty)		2.8	
Maximum travel speed		km/hr (mph)	41.0 (25.5)	
Braking distance		m (ft-in)	12 (39' 4")	
Minimum turning radius (center of outside tire)			6.09 (20' 0")	
Gradeability		degree (°)	30	
Travel speed	Forward	First gear	6.9 (4.3)	
		Second gear	12.3 (7.7)	
		Third gear	26.9 (16.8)	
		Fourth gear	41.0 (25.5)	
	Reverse	First gear	6.9 (4.3)	
		Second gear	12.3 (7.7)	
Third gear		26.9 (16.8)		

3. WEIGHT

Item		kg	lb
Front frame assembly		2154	4750
Rear frame assembly		2417	5330
Front fender (LH & RH)		48	106
Counterweight		1300	2870
Additional counterweight (HL770XTD-9)		490	1080
Cab assembly		1050	2320
Engine assembly		738	1630
Transmission assembly		753	1660
Drive shaft (front)		37	82
Drive shaft (center)		37	82
Drive shaft (rear)		21	46
Front axle (include differential)		1150	2540
Rear axle (include differential)		1050	2310
Tire (26.5-25 20PR, L3)		394	870
Hydraulic tank assembly		306	670
Fuel tank assembly		440	970
Main pump assembly		80	176
Fan & brake pump assembly		7	15
Main control valve (3 spool)		75	165
Flow amplifier		29	64
Boom assembly	HL770-9	1610	3550
	HL770XTD-9	1820	4010
Bell crank assembly		460	1010
Bucket link		73	160
4.2 m ³ bucket, with bolt on cutting edge		2160	4760
4.0 m ³ bucket, with tooth		2070	4560
Boom cylinder assembly		225	496
Bucket cylinder assembly		235	518
Steering cylinder assembly		44	97
Seat		40	88
Battery		55	121

4. SPECIFICATION FOR MAJOR COMPONENTS

1) ENGINE

Item	Specification
Model	Cummins QSL
Type	4-cycle turbocharged, charge air cooled diesel engine
Control type	Electronic control
Cooling method	Water cooling
Number of cylinders and arrangement	6 cylinders, in-line
Firing order	1-5-3-6-2-4
Combustion chamber type	Direct injection type
Cylinder bore × stroke	114 × 145 mm(4.49" × 5.71")
Piston displacement	8900cc (543 cu in)
Compression ratio	17.8 : 1
Rated gross horse power	284 ps at 2000 rpm
Maximum gross torque at 1400rpm	148 kgf · m (1070 lbf · ft)
Engine oil quantity	23 ℓ (6.1 U.S. gal)
Wet weight	738 kg (1627 lb)
High idling speed	2030 ± 50 rpm
Low idling speed	800 ± 50 rpm
Rated fuel consumption	178 g/ps · hr
Starting motor	Nippondenso (24 V - 7.5kW)
Alternator	Delco Remy 22SI (24 V - 70Amp)
Battery	2 × 12V × 200Ah

2) MAIN PUMP

Item	Specification	
	Steering	Loader
Type	Variable tandem piston pump	
Capacity	110 cc/rev	61 cc/rev
Maximum operating pressure	280 kgf/cm ² (3980 psi)	
Rated oil quantity	220 l /min (58.1 U.S.gpm)	122 l /min (32.2 U.S.gpm)
Rated speed	2000 rpm	

3) FAN + BRAKE PUMP

Item	Specification	
	Fan	Brake
Type	Fixed displacement tandem gear pump	
Capacity	22.4 cc/rev	11.9 cc/rev
Maximum operating pressure	120 kgf/cm ² (1710 psi)	150 kgf/cm ² (2130 psi)
Rated oil quantity	44.8 l /min (11.8 U.S.gpm)	23.8 l /min (6.3 U.S.gpm)
Rated speed	2000 rpm	

4) MAIN CONTROL VALVE

Item	Specification
Type	2 spool
Operating method	Hydraulic pilot assist
Main relief valve pressure	280 kgf/cm ² (3980 psi)
Overload relief valve pressure	340 kgf/cm ² (4840 psi)
Overload relief valve pressure (dump)	310 kgf/cm ² (4410 psi)

5) REMOTE CONTROL VALVE

Item	Specification	
Type	Pressure reducing type	
Operating pressure	Minimum	5 kgf/cm ² (71 psi)
	Maximum	30 kgf/cm ² (427 psi)
Single operation angle	degree	17

6) CYLINDER

Item		Specification
Boom cylinder	Bore dia × Rod dia × Stroke	∅ 160 × ∅ 95 × 765 mm
Bucket cylinder	Bore dia × Rod dia × Stroke	∅ 180 × ∅ 95 × 570 mm
Steering cylinder	Bore dia × Rod dia × Stroke	∅ 95 × ∅ 50 × 480 mm

7) DYNAMIC POWER TRANSMISSION DEVICES

Item		Specification	
Transmission	Model	ZF 4WG260	
	Type	Converter	Single-stage, single-phase
		Transmission	Full-automatic power shift
	Converter stall ratio	2.09 : 1	
	Gear shift	Forward fourth gear, reverse third gear	
	Control	Electrical single lever type, kick-down system Automatic kick down from 2nd to 1st gear FNR switch on joystick lever (option)	
	Pump rated flow	135 ℓ /min (35.7 U.S.gpm) at 2000 rpm	
Axle	Drive devices	4-wheel drive	
	Front	Front fixed location	
	Rear	Oscillation ± 13° of center pin-loaded	
Wheels	Tires	26.5-25, 20PR (L3)	
Brakes	Travel	Four-wheel, wet-disc type, full hydraulic	
	Parking	Spring applied, hydraulic released brake	
Steering	Type	Full hydraulic, articulated	
	Steering angle	40° to both right and left angle, respectively	

5. TIGHTENING TORQUE OF MAJOR COMPONENT

No.	Descriptions	Bolt size	Torque		
			kgf · m	lbf · ft	
1	Engine	Engine mounting bolt, nut (rubber, 2EA)	M24 × 3.0	100 ± 15	723 ± 108
2		Engine mounting bolt (bracket, 8EA)	M12 × 1.75	10.7 ± 1.6	77.4 ± 11.6
3		Engine mounting bolt (flywheel housing, 12EA)	M10 × 1.5	4.6 ± 0.7	33.3 ± 5.1
4		Radiator mounting bolt	M16 × 2.0	29.7 ± 4.5	215 ± 32.5
5		Fuel tank mounting bolt, nut	M16 × 2.0	29.7 ± 4.5	215 ± 32.5
6	Hydraulic system	Main pump housing mounting bolt	M14 × 2.0	19.6 ± 2.9	142 ± 21.0
7		Fan & brake pump housing mounting bolt	M10 × 1.5	6.9 ± 1.4	50 ± 10.1
8		Main control valve mounting bolt	M12 × 1.75	12.8 ± 3.0	92.6 ± 21.7
9		Steering unit mounting bolt	M10 × 1.5	6.9 ± 1.4	50 ± 10.1
10		Flow amplifier mounting bolt	M10 × 1.5	6.9 ± 1.4	50 ± 10.1
11		Brake valve mounting bolt	M8 × 1.25	2.5 ± 0.5	18.1 ± 3.6
12		Cut-off valve mounting bolt	M12 × 1.75	12.8 ± 3.0	89 ± 21.7
13		Remote control lever mounting bolt	M6 × 1.0	1.1 ± 0.2	8.0 ± 1.4
14		Stop valve	M10 × 1.5	6.9 ± 1.4	50 ± 10.1
15		Safety valve	M10 × 1.5	6.9 ± 1.4	50 ± 10.1
16	Hydraulic oil tank mounting bolt	M20 × 2.5	57.9	419	
17	Power train system	Transmission bolt, nut (rubber, 4EA)	M24 × 3.0	100 ± 15	723 ± 108
18		Transmission bolt (bracket, engine side)	M16 × 2.0	19.4 ± 3.0	140 ± 21.7
19		Transmission bolt (bracket, T/M side)	M20 × 2.5	46.3 ± 7.0	335 ± 50.6
20		Front axle mounting bolt, nut	M33 × 2.0	199 ± 29	1439 ± 216
21		Rear axle support mounting bolt, nut	M36 × 3.0	308 ± 46.2	2228 ± 334
22		Tire mounting nut	M22 × 1.5	79 ± 2.5	571 ± 18
23	Others	Drive shaft joint mounting bolt, nut	1/2-20UNF	15 ± 2.0	108 ± 14.5
24		Counterweight mounting bolt	M30 × 3.5	199 ± 30	1439 ± 217
25		Additional counterweight mounting bolt	M24 × 3.0	100 ± 15	723 ± 108
26		Operator's seat mounting bolt	M8 × 1.25	3.4 ± 0.8	24.6 ± 5
27		ROPS Cab mounting bolt (4EA)	M20 × 2.5	58 ± 8.7	419 ± 63

6. TORQUE CHART

Use following table for unspecified torque.

1) BOLT AND NUT

(1) Coarse thread

Bolt size	8T		10T	
	kg · m	lb · ft	kg · m	lb · ft
M 6 × 1.0	0.85 ~ 1.25	6.15 ~ 9.04	1.14 ~ 1.74	8.2 ~ 12.6
M 8 × 1.25	2.0 ~ 3.0	14.5 ~ 21.7	2.73 ~ 4.12	19.5 ~ 29.8
M10 × 1.5	4.0 ~ 6.0	28.9 ~ 43.4	5.5 ~ 8.3	39.8 ~ 60
M12 × 1.75	7.4 ~ 11.2	53.5 ~ 79.5	9.8 ~ 15.8	71 ~ 114
M14 × 2.0	12.2 ~ 16.6	88.2 ~ 120	16.7 ~ 22.5	121 ~ 167
M16 × 2.0	18.6 ~ 25.2	135 ~ 182	25.2 ~ 34.2	182 ~ 247
M18 × 2.5	25.8 ~ 35.0	187 ~ 253	35.1 ~ 47.5	254 ~ 343
M20 × 2.5	36.2 ~ 49.0	262 ~ 354	49.2 ~ 66.6	356 ~ 482
M22 × 2.5	48.3 ~ 63.3	350 ~ 457	65.8 ~ 98.0	476 ~ 709
M24 × 3.0	62.5 ~ 84.5	452 ~ 611	85.0 ~ 115	615 ~ 832
M30 × 3.0	124 ~ 168	898 ~ 1214	169 ~ 229	1223 ~ 1655
M36 × 4.0	174 ~ 236	1261 ~ 1703	250 ~ 310	1808 ~ 2242

(2) Fine thread

Bolt size	8T		10T	
	kg · m	lb · ft	kg · m	lb · ft
M 8 × 1.0	2.17 ~ 3.37	15.7 ~ 24.3	3.04 ~ 4.44	22.0 ~ 32.0
M10 × 1.25	4.46 ~ 6.66	32.3 ~ 48.2	5.93 ~ 8.93	42.9 ~ 64.6
M12 × 1.25	7.78 ~ 11.58	76.3 ~ 83.7	10.6 ~ 16.0	76.6 ~ 115
M14 × 1.5	13.3 ~ 18.1	96.2 ~ 130	17.9 ~ 24.1	130 ~ 174
M16 × 1.5	19.9 ~ 26.9	144 ~ 194	26.6 ~ 36.0	193 ~ 260
M18 × 1.5	28.6 ~ 43.6	207 ~ 315	38.4 ~ 52.0	278 ~ 376
M20 × 1.5	40.0 ~ 54.0	289 ~ 390	53.4 ~ 72.2	386 ~ 522
M22 × 1.5	52.7 ~ 71.3	381 ~ 515	70.7 ~ 95.7	512 ~ 692
M24 × 2.0	67.9 ~ 91.9	491 ~ 664	90.9 ~ 123	658 ~ 890
M30 × 2.0	137 ~ 185	990 ~ 1338	182 ~ 248	1314 ~ 1795
M36 × 3.0	192 ~ 260	1389 ~ 1879	262 ~ 354	1893 ~ 2561

2) PIPE AND HOSE (FLARE type)

Thread size	Width across flat (mm)	kgf · m	lbf · ft
1/4"	19	4	28.9
3/8"	22	5	36.2
1/2"	27	9.5	68.7
3/4"	36	18	130
1"	41	21	152
1-1/4"	50	35	253

3) PIPE AND HOSE (ORFS type)

Thread size	Width across flat (mm)	kgf · m	lbf · ft
9/16-18	19	4	28.9
11/16-16	22	5	36.2
13/16-16	27	9.5	68.7
1-3/16-12	36	18	130
1-7/16-12	41	21	152
1-11/16-12	50	35	253

4) FITTING

Thread size	Width across flat (mm)	kgf · m	lbf · ft
1/4"	19	4	28.9
3/8"	22	5	36.2
1/2"	27	9.5	68.7
3/4"	36	18	130
1"	41	21	152
1-1/4"	50	35	253

7. RECOMMENDED LUBRICANTS

Use only oils listed below or equivalent.

Do not mix different brand oil.

Service point	Kind of fluid	Capacity l (U.S. gal)	Ambient temperature °C (°F)							
			-20 (-4)	-10 (14)	0 (32)	10 (50)	20 (68)	30 (86)	40 (104)	
Engine oil pan	Engine oil	23 (6.1)				SAE 30				
			SAE 10W							
			SAE 10W-30							
			SAE 15W-40							
Transmission	Engine oil	43 (11.4)	SAE 10W-30							
			SAE 15W-40							
Axle	UTTO	Front : 51 (13.5) Rear : 43 (11.4)	*Refer to below list							
Hydraulic tank	Hydraulic oil	Tank: 200 (52.8) System: 320 (85)	ISO VG 32							
			ISO VG 46							
			ISO VG 68							
Fuel tank	Diesel fuel	457 (120.7)	ASTM D975 NO.1							
			ASTM D975 NO.2							
Fitting (grease nipple)	Grease	As required	NLGI NO.1							
			NLGI NO.2							
Radiator	Mixture of antifreeze and water 50 : 50	56 (14.8)	Ethylene glycol base permanent type							

- SAE : Society of Automotive Engineers
- API : American Petroleum Institute
- ISO : International Organization for Standardization
- NLGI : National Lubricating Grease Institute
- ASTM : American Society of Testing and Material
- UTTO : Universal Tractor Transmission Oil

- ★ Recommended oil list
- BP TERRAC SUPER TRANSMISSION 10W-30
- CASTROL AGRI TRANS PLUS 10W-30
- MOBILFLUID 426
- SHELL DONAX TD 10W-30
- TOTAL DYNATRANS MPV