

GROUP 2 ELECTRICAL CIRCUIT

ELECTRICAL CIRCUIT (1/2) : Machine serial No. #0092

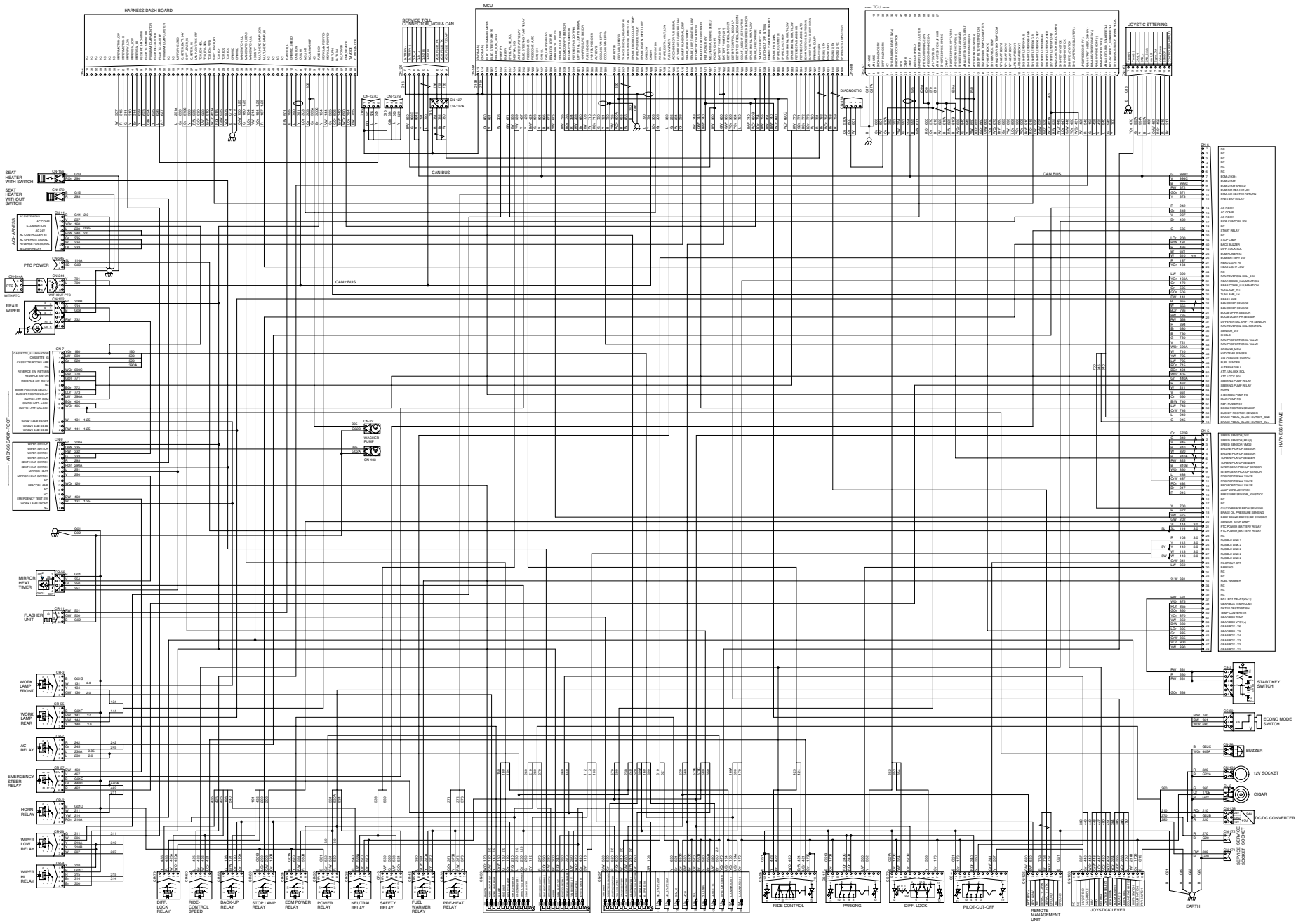

TO SHEET 2 OF 2

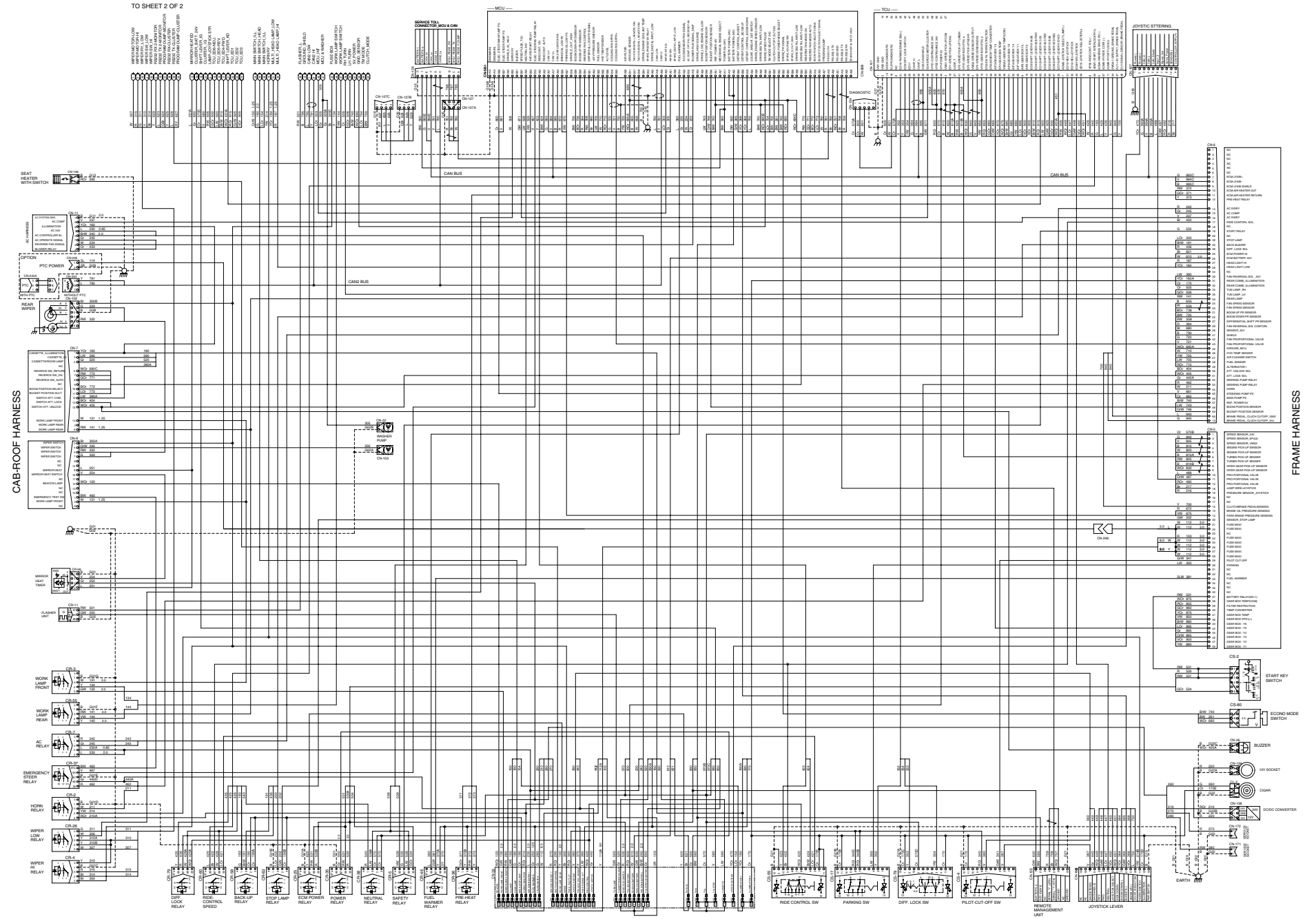

ELECTRICAL CIRCUIT (2/2) : Machine serial No. #0092

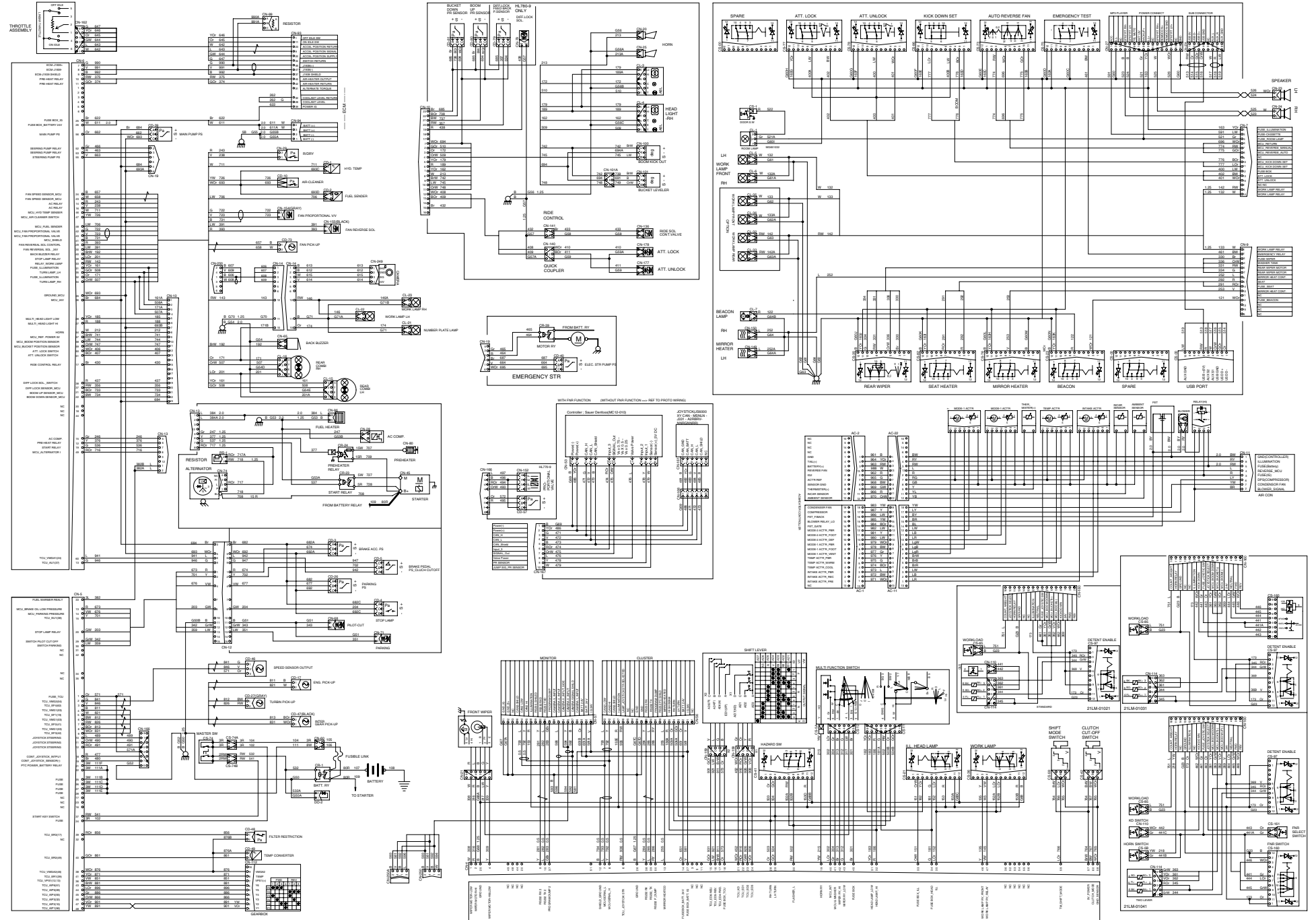

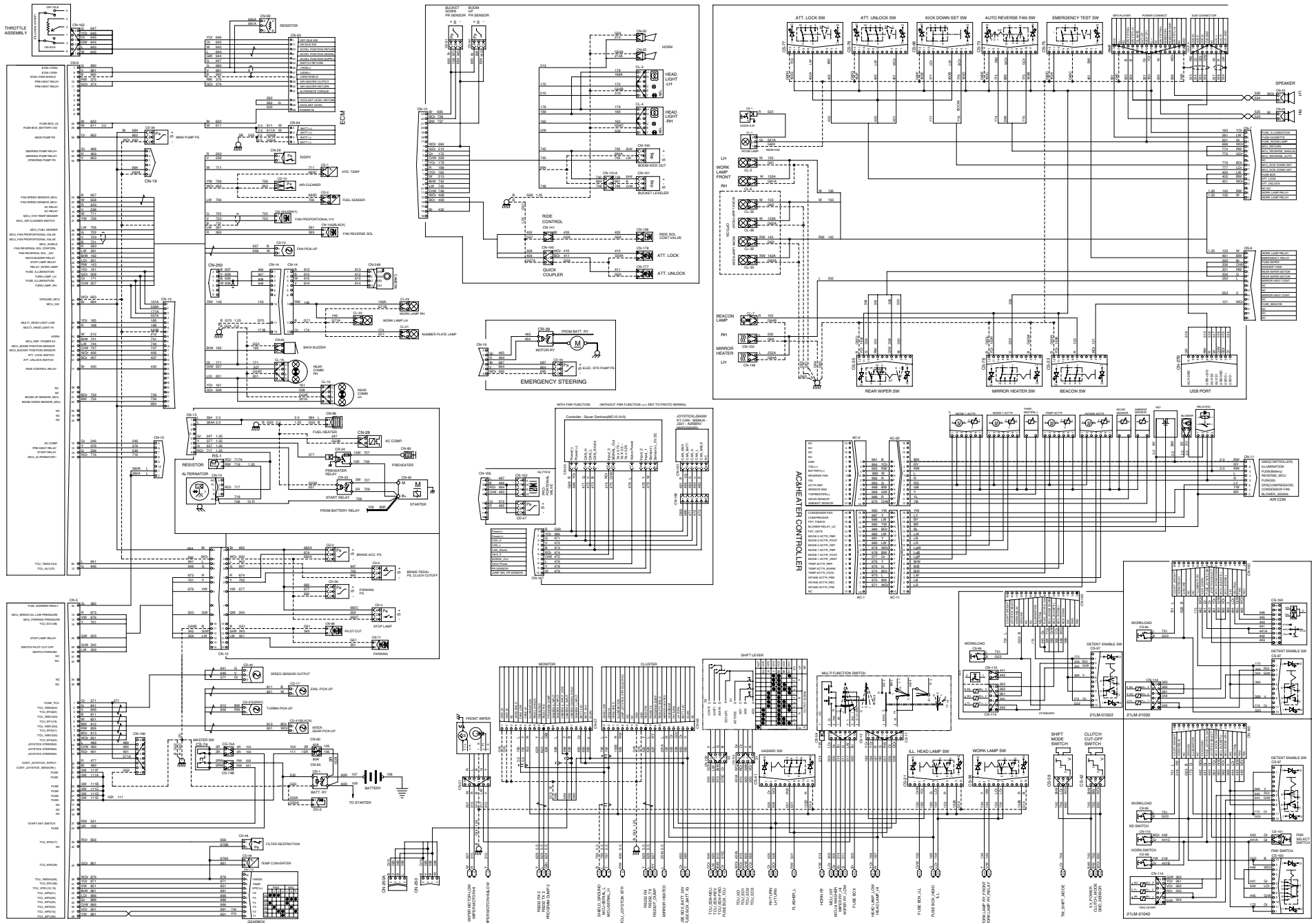



1. ILLUMINATION CIRCUIT

1) OPERATING FLOW

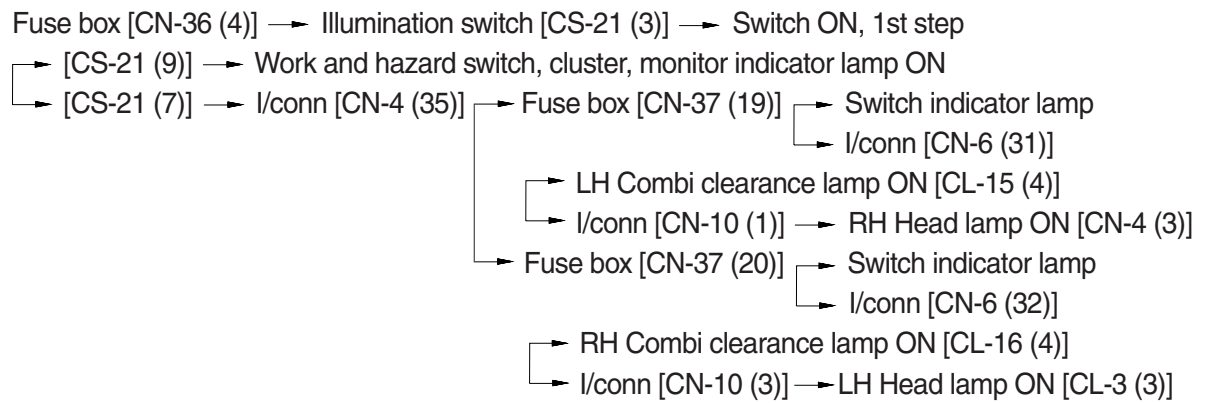

2) CHECK POINT

Engine	Key switch	Check point	Voltage
OFF	ON	① - GND (switch input) ② - GND (switch output) ③ - GND (to light)	20~25V

※ GND : Ground

ILLUMINATION CIRCUIT

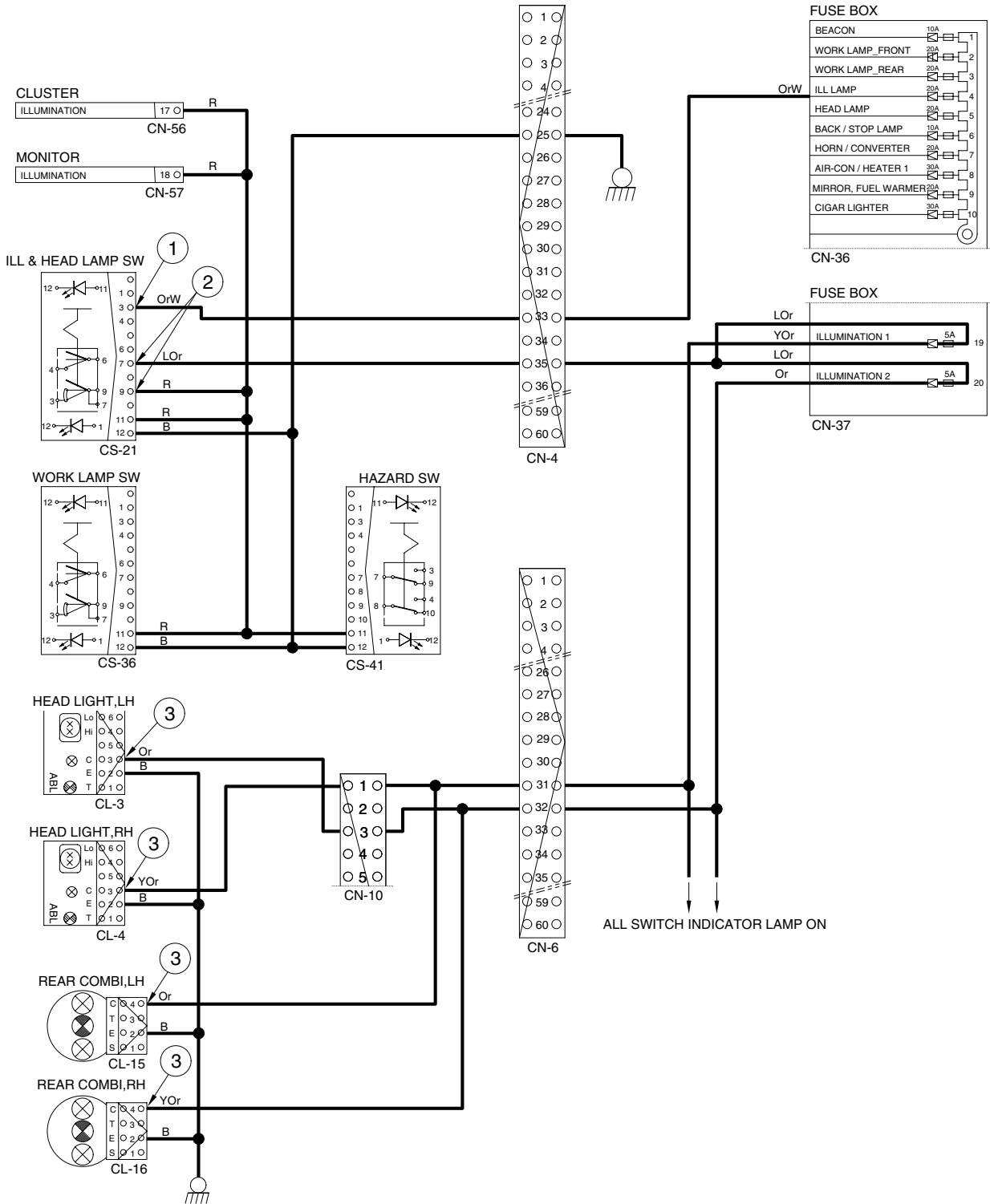

2. HEAD LIGHT CIRCUIT

1) OPERATING FLOW

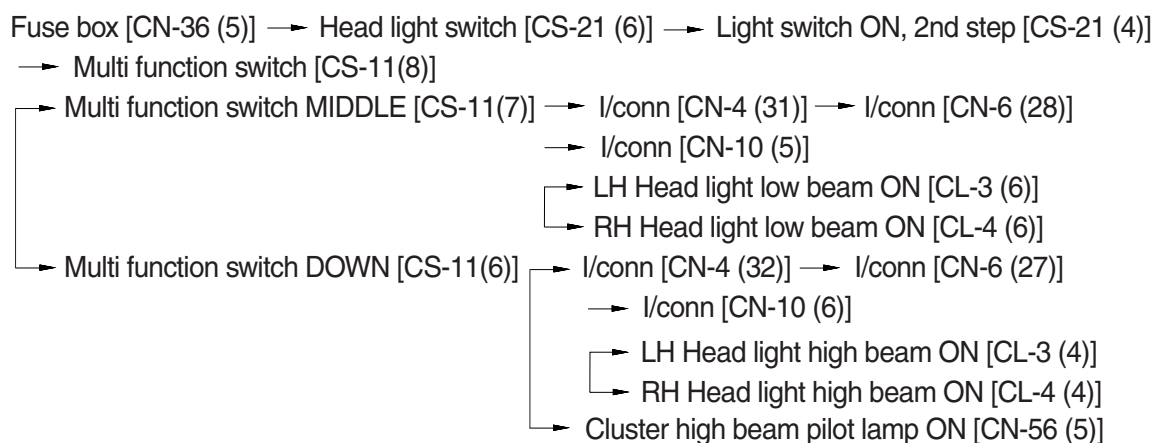

2) CHECK POINT

Engine	Key switch	Check point	Voltage
OFF	ON	① - GND (switch input) ② - GND (switch output) ③ - GND (multi function input) ④ - GND (multi function output) ⑤ - GND (multi function output) ⑥ - GND (low beam) ⑦ - GND (high beam) ⑧ - GND (passing B ⁺)	20~25V

※ GND : Ground

HEAD LIGHT CIRCUIT

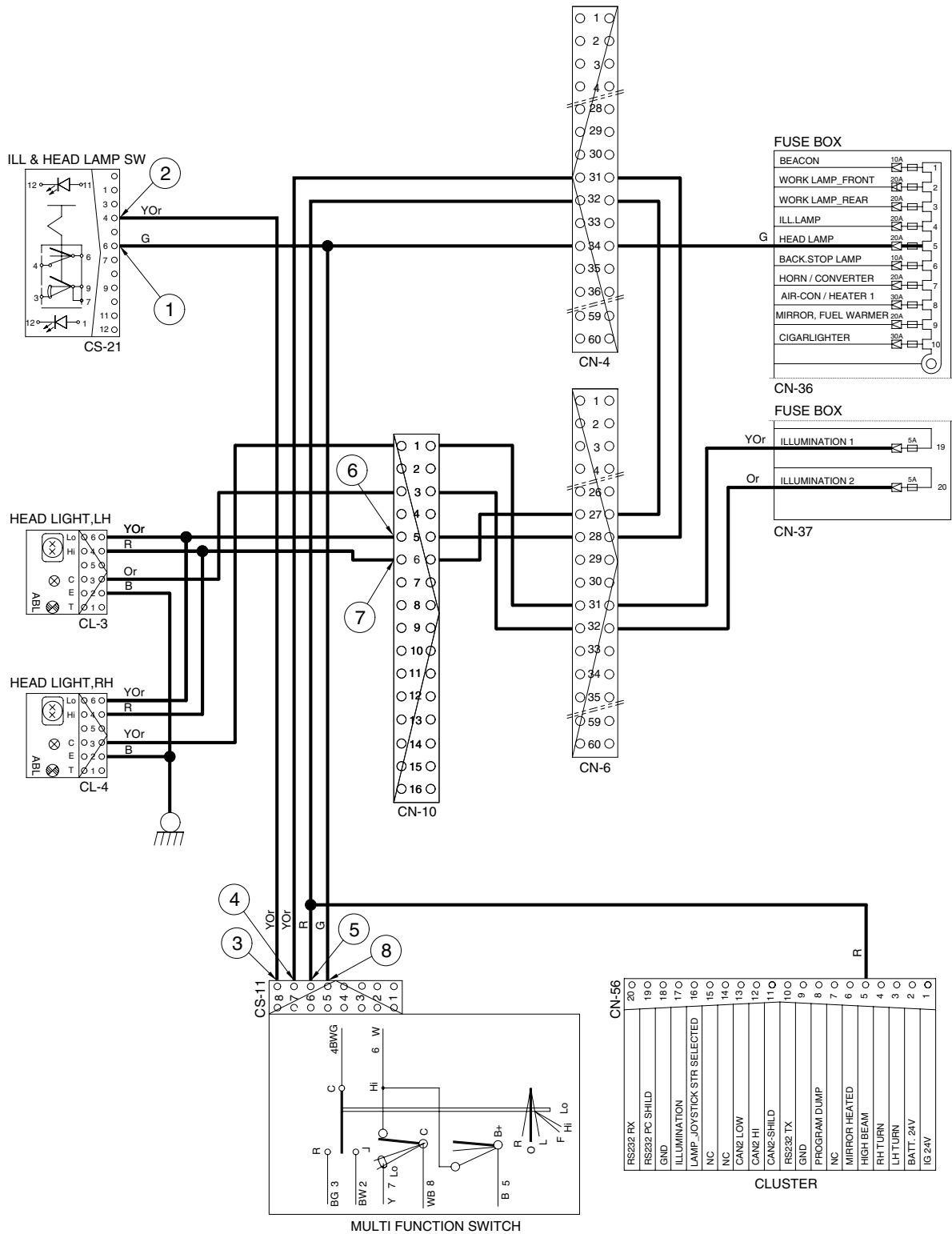

75797EL04

3. WORK LIGHT SWITCH

1) OPERATING FLOW

※ Illumination switch : ON position (1st step)

(1) Work lamp switch ON (1st step)

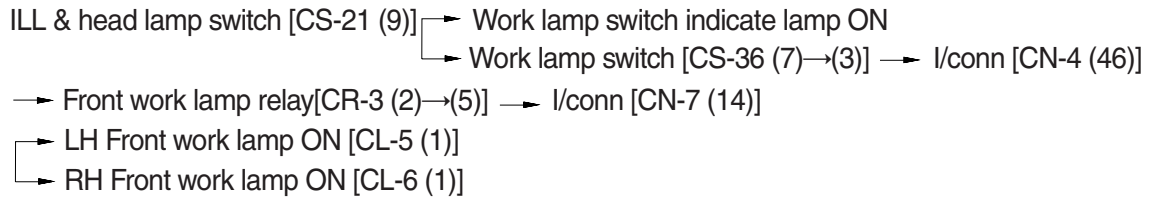

(2) Work lamp switch (2nd step)

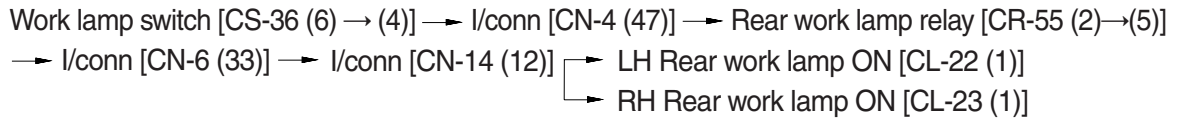

2) CHECK POINT

Engine	Key switch	Check point	Voltage
OFF	ON	① - GND (work lamp power input) ② - GND (work lamp power output) ③ - GND (front work lamp) ④ - GND (rear work lamp)	20~25V

※ GND : Ground

WORK LIGHT SWITCH

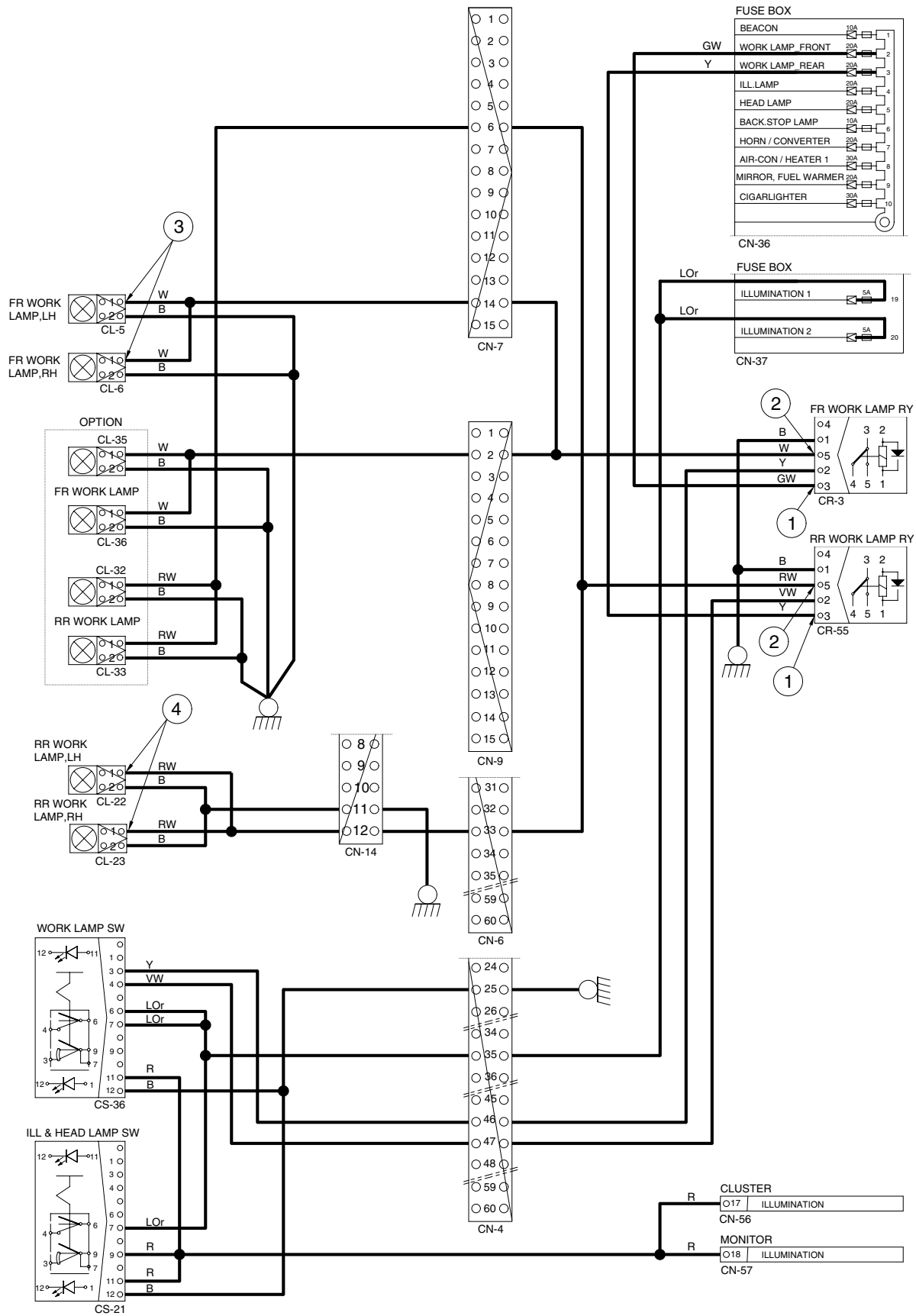

STARTING CIRCUIT

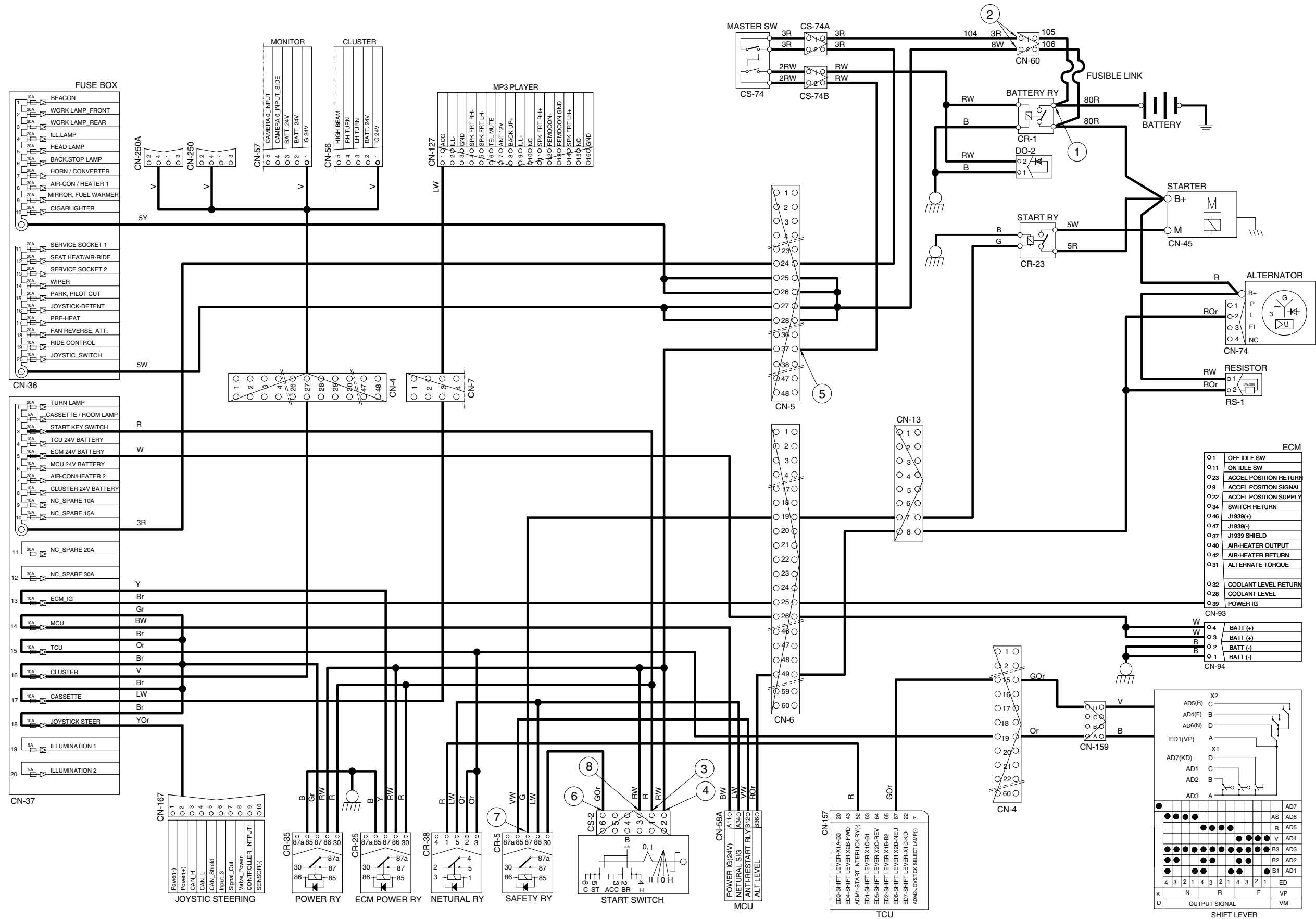

5. CHARGING CIRCUIT

When the starter is activated and the engine is started, the operator releases the key switch to the ON position.

Charging current generated by operating alternator flows into the battery through the battery relay (CR-1).

The current also flows from alternator to each electrical component and controller through the fuse box.

1) OPERATING FLOW

(1) Warning flow

Alternator [CN-74 (2)] → I/conn [CN-13 (8)] → I/conn [CN-6 (49)] → MCU [CN-58A (B36)]
 → Cluster charge warning lamp ON

(2) Charging flow

Alternator → Starter [CN-45 (B⁺)] → Battery relay [CR-1]
 → Battery(+) terminal → Charging
 → Fusible link [CN-60 (1)] → Master switch [CS-74 (1)→(2)] → I/conn [CN-5 (24)]
 → Fuse box [CN-37]
 → Fusible link [CN-60 (2)] → I/conn [CN-5 (25~28)] → Fuse box [CN-36]

2) CHECK POINT

Engine	Key switch	Check point	Voltage
OFF	ON	① - GND (battery) ② - GND (battery relay) ③ - GND (alternator B ⁺) ④ - GND (alternator 2) ⑤ - GND (MCU) ⑥ - GND (fuse box)	20~28V

※ GND : Ground

※ MCU : Machine control unit

CHARGING CIRCUIT

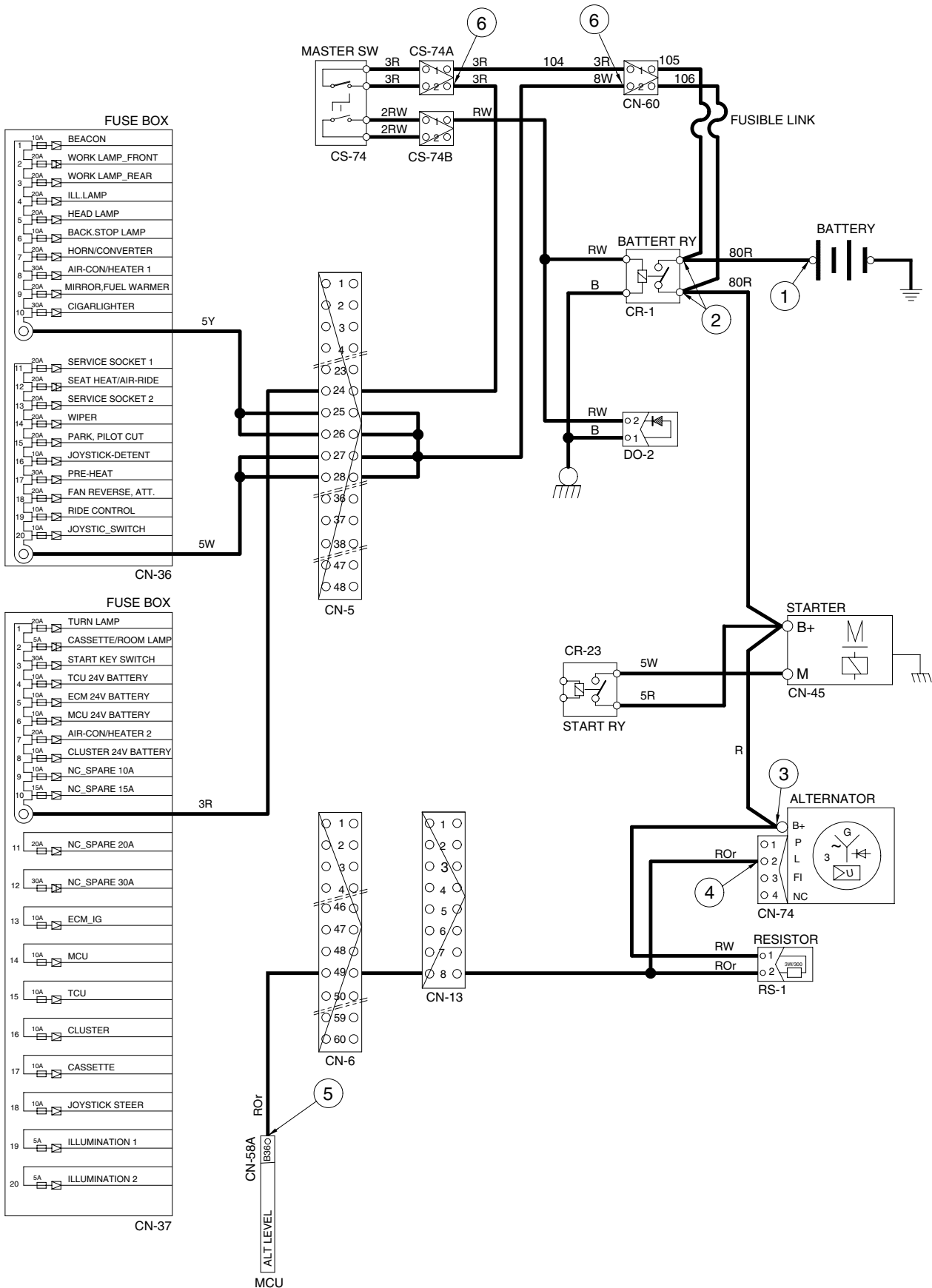

75797EL07

6. ELECTRIC PARKING, PILOT CUT OFF CIRCUIT

1) OPERATING FLOW

(1) Parking OFF

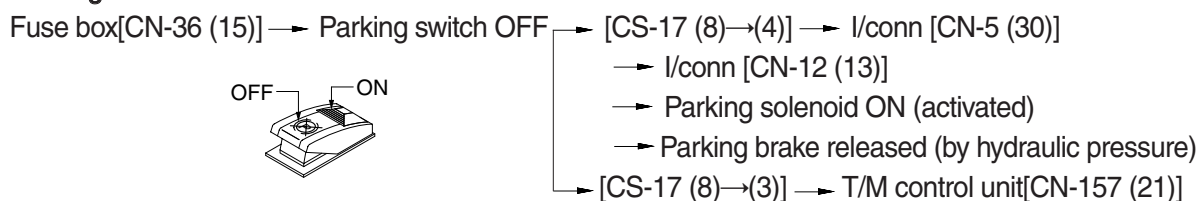

(2) Parking ON

Fuse box [CN-36 (15)] → Parking switch ON → Parking solenoid [CN-71] OFF
 → Parking brake applied [By spring force]

(3) Pilot cut off ON

Fuse box [CN-36 (15)] → Pilot cut off switch ON → Pilot cut off switch [CS-4 (8)→(4)]
 → I/conn [CN-5 (29)] → I/conn [CN-12 (12)] → Pilot cut off solenoid ON [CN-68] (activate)
 → Pilot cut off released

(4) Pilot cut off OFF

Fuse box [CN-36 (15)] → Pilot cut off solenoid [CN-68] OFF
 → Pilot cut off applied

2) CHECK POINT

Engine	Key switch	Check point	Voltage
Running	ON	① - GND (parking switch input) ② - GND (parking switch output) ③ - GND (pilot cut off switch input) ④ - GND (pilot cut off switch output) ⑤ - GND (parking solenoid) ⑥ - GND (pilot cut off solenoid)	20~25V

※ GND : Ground

ELECTRIC PARKING, PILOT CUT OFF CIRCUIT

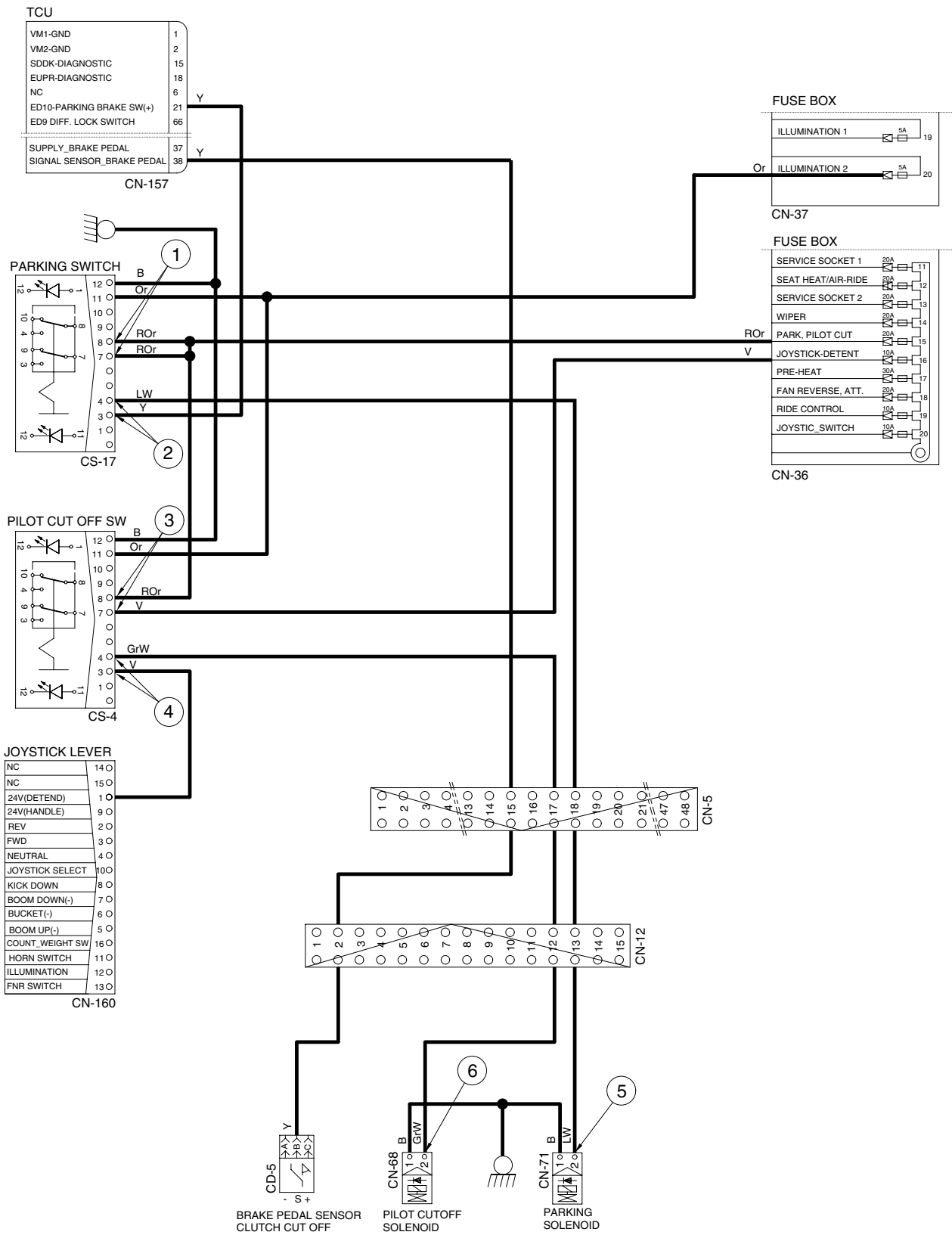

7. WIPER AND WASHER CIRCUIT

1) OPERATING FLOW

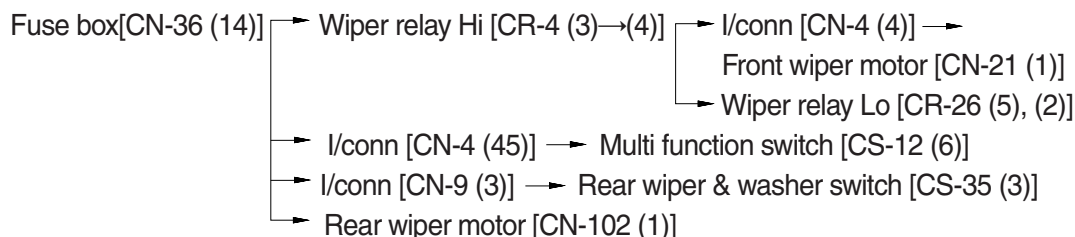

(1) Front washer switch ON

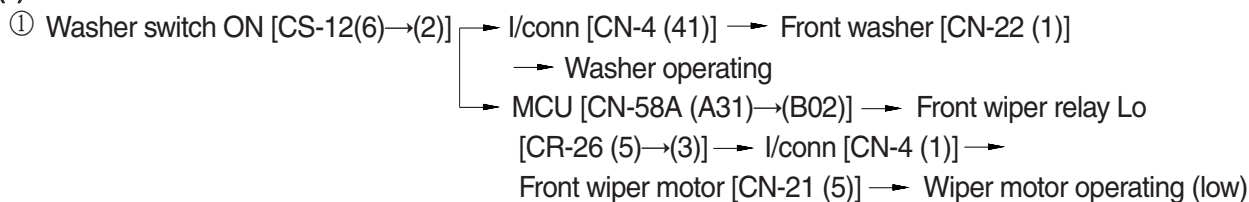

(2) Front wiper switch ON

① INT position

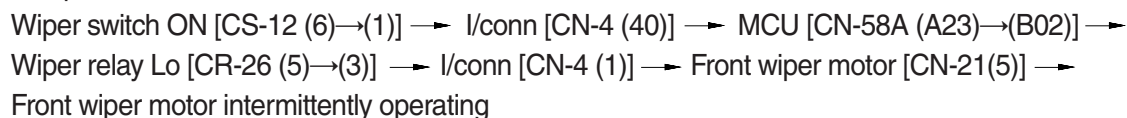

② Lo position

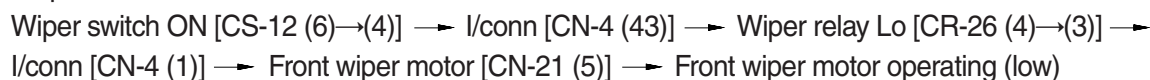

③ Hi position

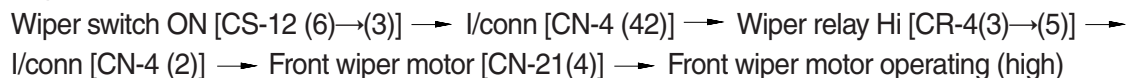

(3) Auto-parking (when switch OFF)

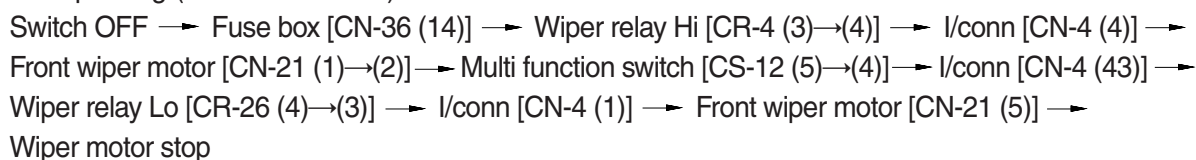

(4) Rear wiper and washer switch

① Wiper switch ON (1st step)

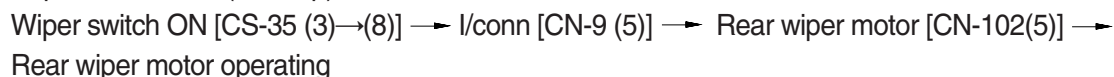

② Washer switch ON (2nd step)

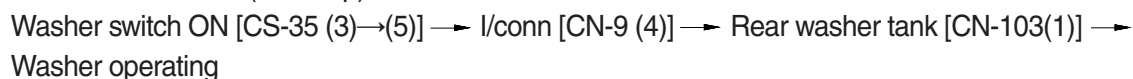

2) CHECK POINT

Condition	Check point	
Engine : Stop	① - GND (front wiper switch power input)	⑥ - GND (wiper relay power input)
	② - GND (rear wiper switch power input)	⑦ - GND (front washer power output)
Key switch : ON	③ - GND (wiper relay power input)	⑧ - GND (rear washer power output)
	④ - GND (front wiper motor Lo power input)	⑨ - GND (front wiper motor power output)
Voltage : 20~25V	⑤ - GND (front wiper motor High power input)	⑩ - GND (rear wiper motor power output)

※ GND : Ground

WIPER AND WASHER CIRCUIT

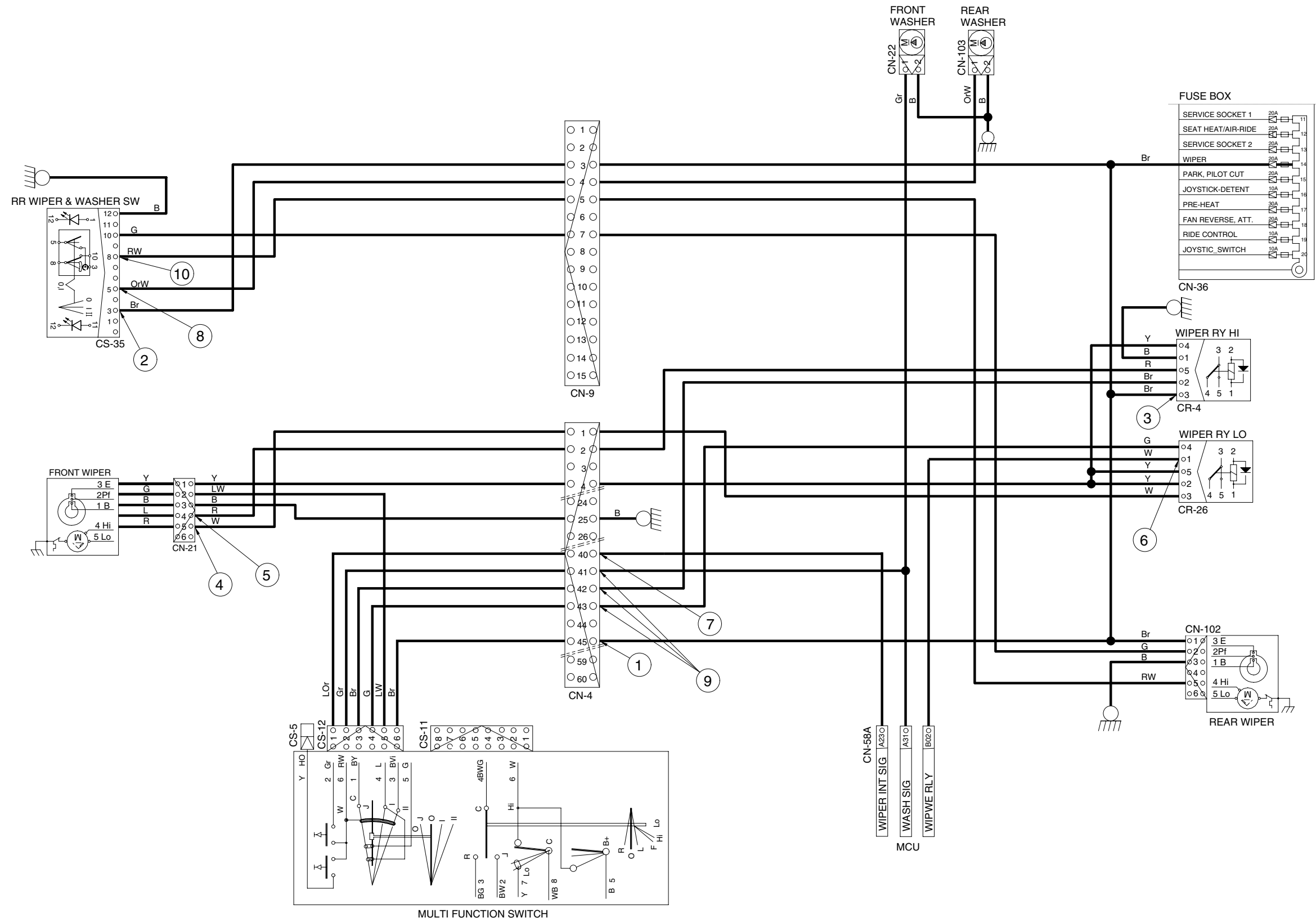

HAZARD, TURN AND ROTARY CIRCUIT

