

## SECTION 3 POWER TRAIN SYSTEM

---

Group 1	Structure and Function	3-1
Group 2	Operational Checks and Troubleshooting	3-59
Group 3	Tests and Adjustments	3-70
Group 4	Disassembly and Assembly	3-73

# SECTION 3 POWER TRAIN SYSTEM

## GROUP 1 STRUCTURE AND FUNCTION

### 1. POWER TRAIN COMPONENT OVERVIEW

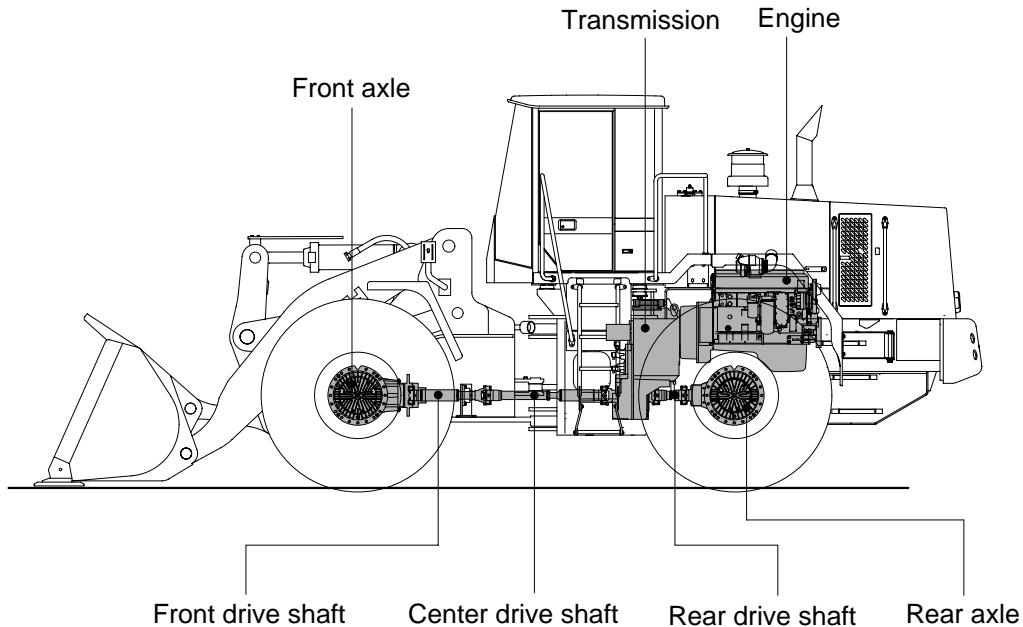

7707PT01

The power train consists of the following components:

- Transmission
- Front, center and rear drive shafts
- Front and rear axles

Engine power is transmitted to the transmission through the torque converter.

The transmission is a hydraulically engaged four speed forward, three speed reverse countershaft type power shift transmission. A calliper-disc type parking brake is located on the front axle.

The transmission outputs through universal joints to three drive shaft assemblies. The front drive shaft is a telescoping shaft which drives the front axle. The front axle is mounted directly to the loader frame. The front axle is equipped with limited slip differential.

The rear axle is mounted on an oscillating pivot. The rear axle is equipped with limited slip differential.

The power transmitted to front axle and rear axle is reduced by the pinion gear and ring gear of differential. It then passes from the differential to the sun gear shaft(Axle shaft) of final drive.

The power of the sun gear is reduced by a planetary mechanism and is transmitted through the planetary hub to the wheel.

# HYDRAULIC CIRCUIT

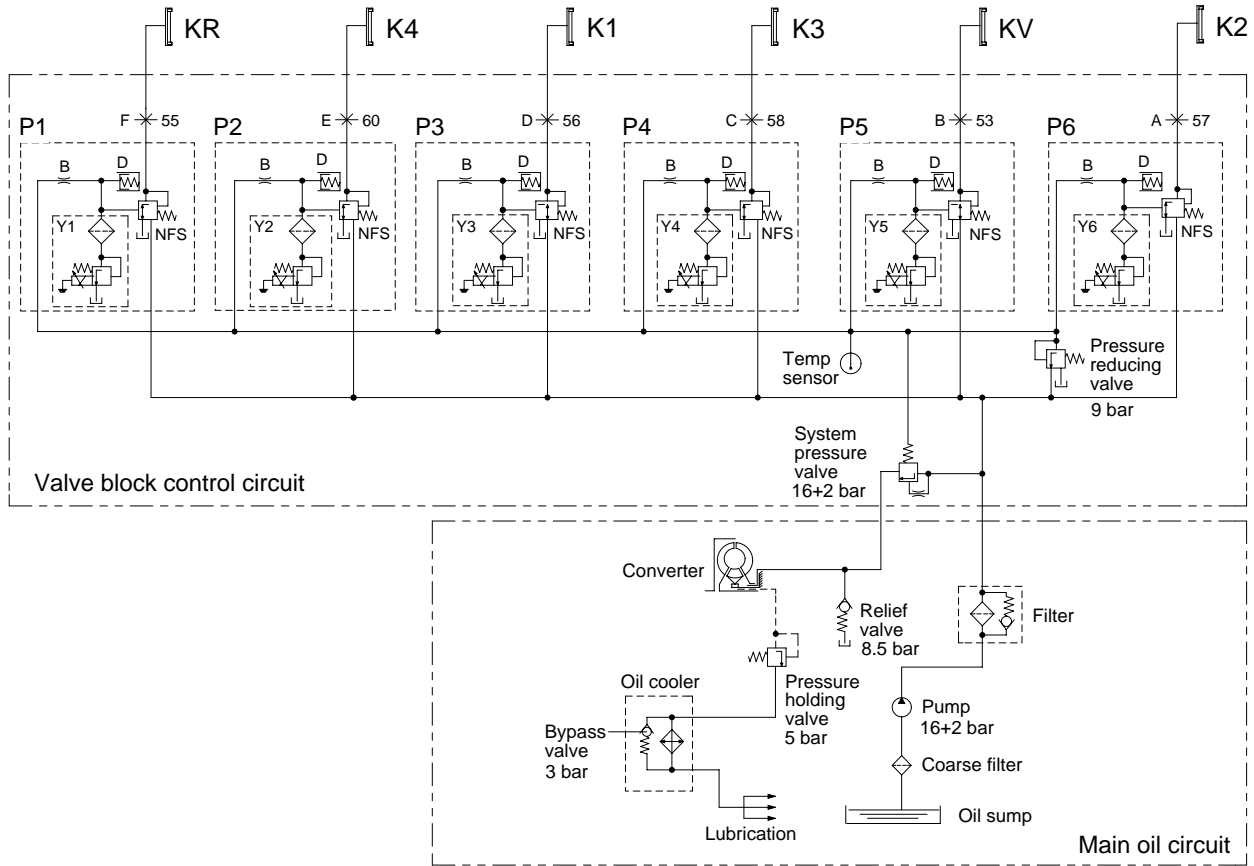

7704PT01

- |     |                              |       |                                      |
|-----|------------------------------|-------|--------------------------------------|
| NFS | Follow-on slide              | P3    | Proportional valve clutch K1         |
| D   | Oscillation damper           | P4    | Proportional valve clutch K3         |
| B   | Orifice                      | P5    | Proportional valve clutch KV         |
| P1  | Proportional valve clutch KR | P6    | Proportional valve clutch K2         |
| P2  | Proportional valve clutch K4 | Y1~Y6 | Pressure regulator valve with filter |

Speed	Forward				Reverse			Neutral	Engaged clutch	Positions on the valve block	Current No. of the measuring points
	1	2	3	4	1	2	3				
Y1					X	X	X		KR	F	55
Y2				X					K4	E	60
Y3	X				X				K1	D	56
Y4			X	X			X		K3	C	58
Y5	X	X	X						KV	B	53
Y6		X				X			K2	A	57
Engaged clutch	K1,KV	KV,K2	KV,K3	K4,K3	KR,K1	KR,K2	KR, K3		-	-	-

X : Pressure regulator under voltage

## 2. TORQUE CONVERTER

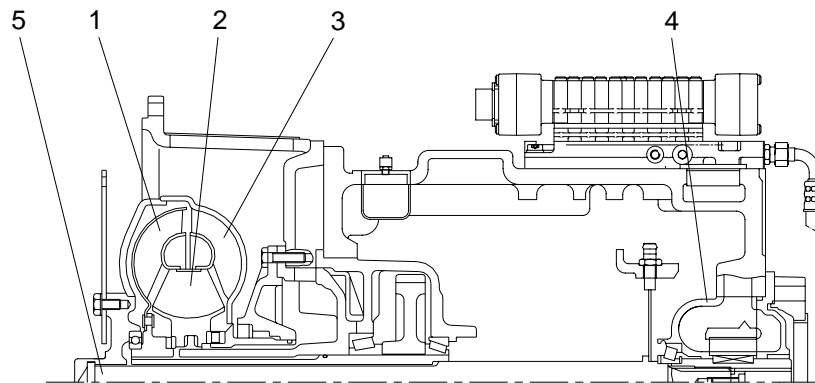

7704PT03

- |   |        |   |                   |   |             |
|---|--------|---|-------------------|---|-------------|
| 1 | Pump   | 3 | Turbine           | 5 | Input shaft |
| 2 | Stator | 4 | Transmission pump |   |             |

The converter is working according to the Trilok-system, i.e. it assumes at high turbine speed the characteristics, and with it the favorable efficiency of a fluid clutch.

The converter will be defined according to the engine power so that the most favorable operating conditions for each installation case are given.

**The Torque converter is composed of 3 main components :**  
**Pump wheel - turbine wheel - stator(Reaction member)**

These 3 impeller wheels are arranged in such a ring-shape system that the fluid is streaming through the circuit components in the indicated order.

Pressure oil is constantly streaming out of the transmission pump through the converter. In this way, the converter can fulfill its task to multiply the torque of the engine, and at the same time, the heat created in the converter is dissipated through the escaping oil.

The oil, escaping out of the pump wheel, enters the turbine wheel and is there inverted in the direction of flow.

According to the rate of inversion, the turbine wheel and with it also the output shaft, receive a more or less high reaction moment. The stator(Reaction member), following the turbine, has the task to inverse again the oil which is escaping out of the turbine and to delivery it under the suitable discharge direction to the pump wheel.

Due to the inversion, the stator receives a reaction moment.

The relation turbine moment/pump moment is called torque conversion. This is the higher the greater the speed difference of pump wheel and turbine wheel will be.

Therefore, the maximum conversion is created at standing turbine wheel.

With increasing output speed, the torque conversion is decreasing. The adaption of the output speed to a certain required output moment is infinitely variable and automatically achieved by the torque converter.

If the turbine speed is reaching about 80% of the pump speed, the conversion becomes 1.0 i.e. the turbine moment becomes equal to that of the pump moment.

From this point on, the converter is working similar to a fluid clutch.

A stator freewheel serves to improve the efficiency in the upper driving range, it is backing up in the conversion range the moment upon the housing, and is released in the coupling range.

In this way, the stator can rotate freely.

**Function of a hydrodynamic torque converter(Schematic view)**

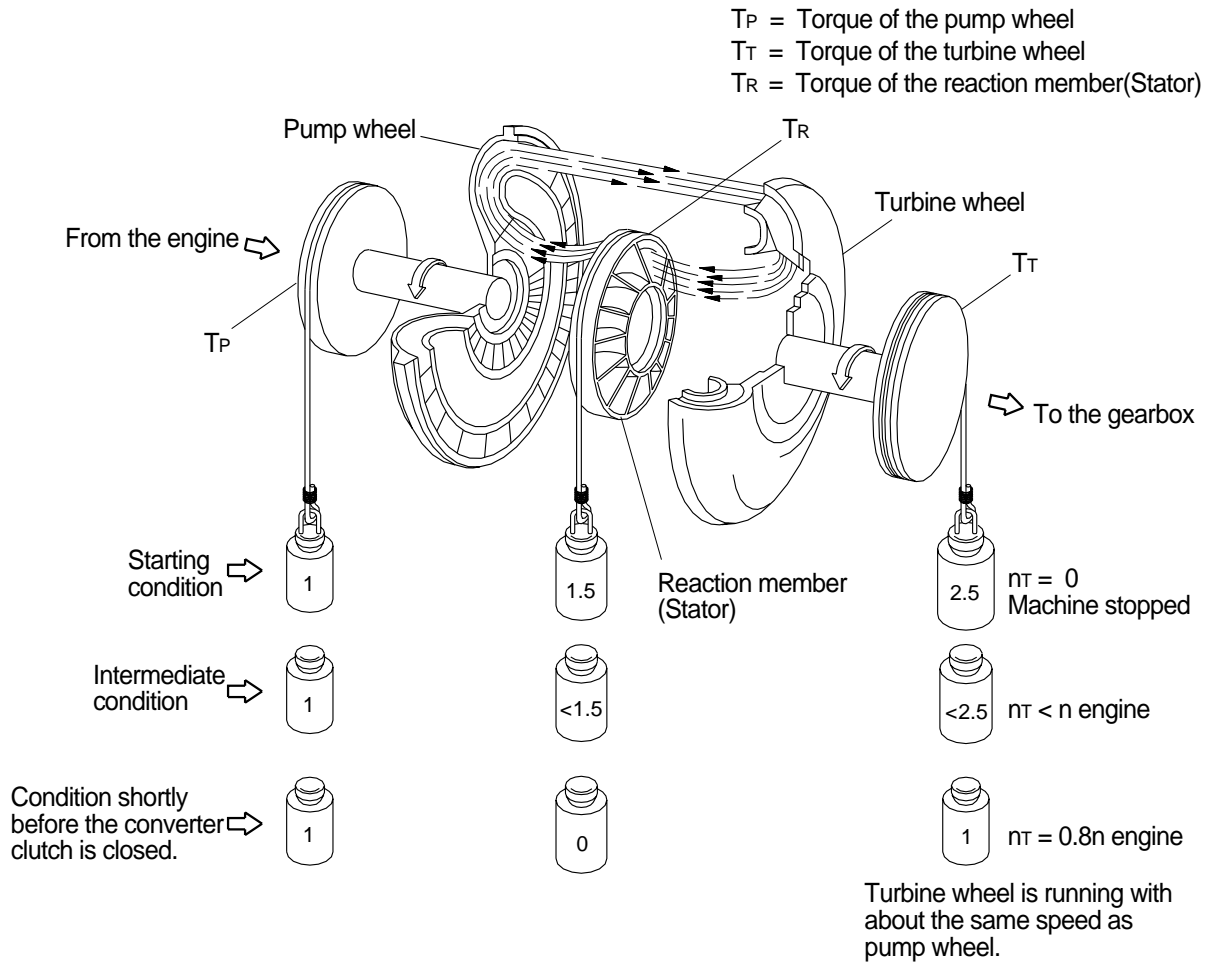

### 3. TRANSMISSION

#### 1) LAYOUT

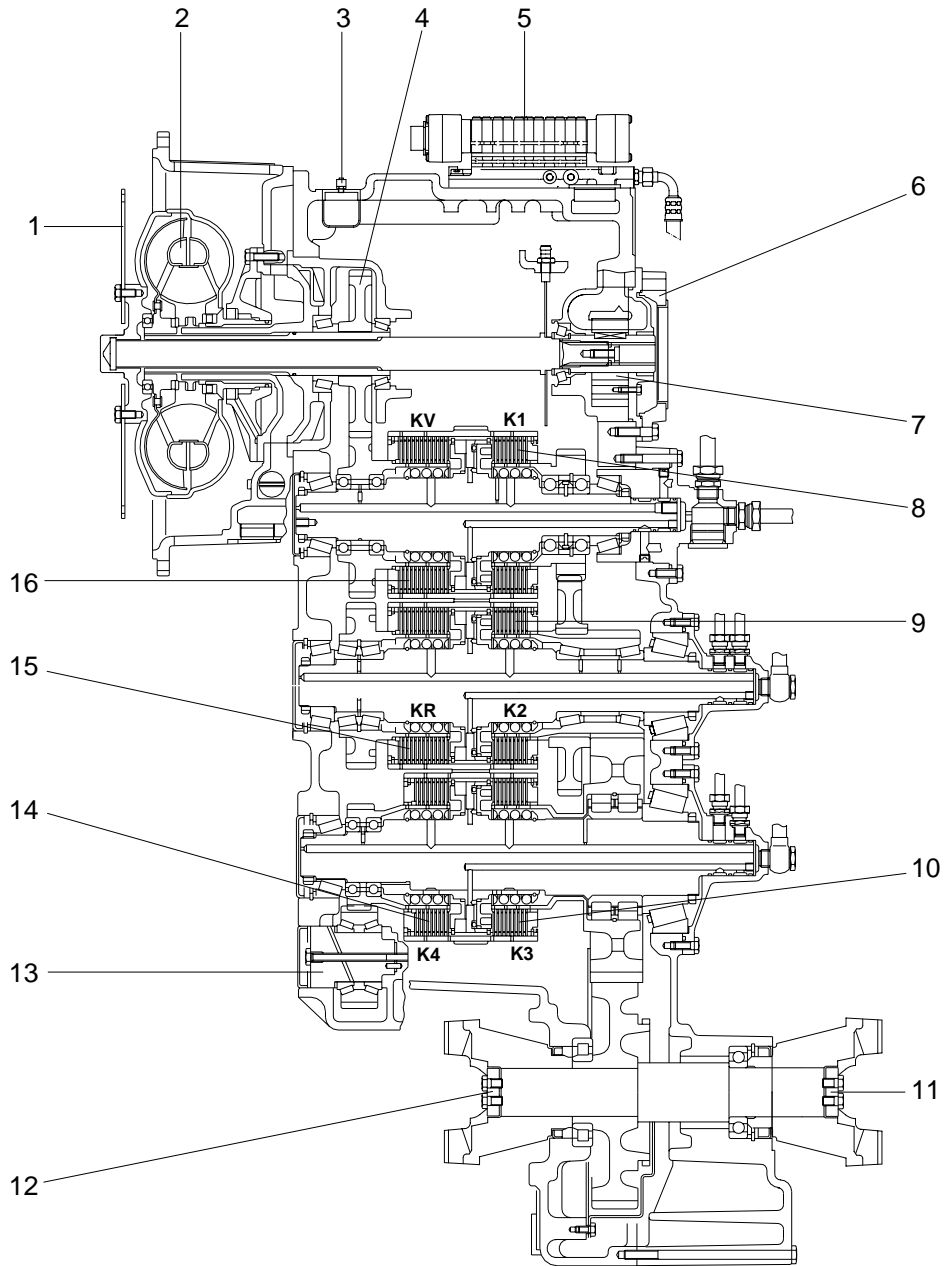

7704PT02

- |   |                                 |    |  |    |                    |
|---|---------------------------------|----|--|----|--------------------|
| 1 | Engine connection               | 7  | Converter change and control pressure pump | 12 | Output shaft       |
| 2 | Torque converter                | 8  | 1st clutch(K1)                             | 13 | Lay shaft          |
| 3 | Breather                        | 9  | 2nd clutch(K2)                             | 14 | 4th clutch(K4)     |
| 4 | Drive                           | 10 | 3rd clutch(K3)                             | 15 | Reverse clutch(KR) |
| 5 | Electro-hydraulic shift control | 11 | Output shaft                               | 16 | Forward clutch(KV) |
| 6 | 1st power take off              |    |  |    |                    |

## 2) INSTALLATION VIEW

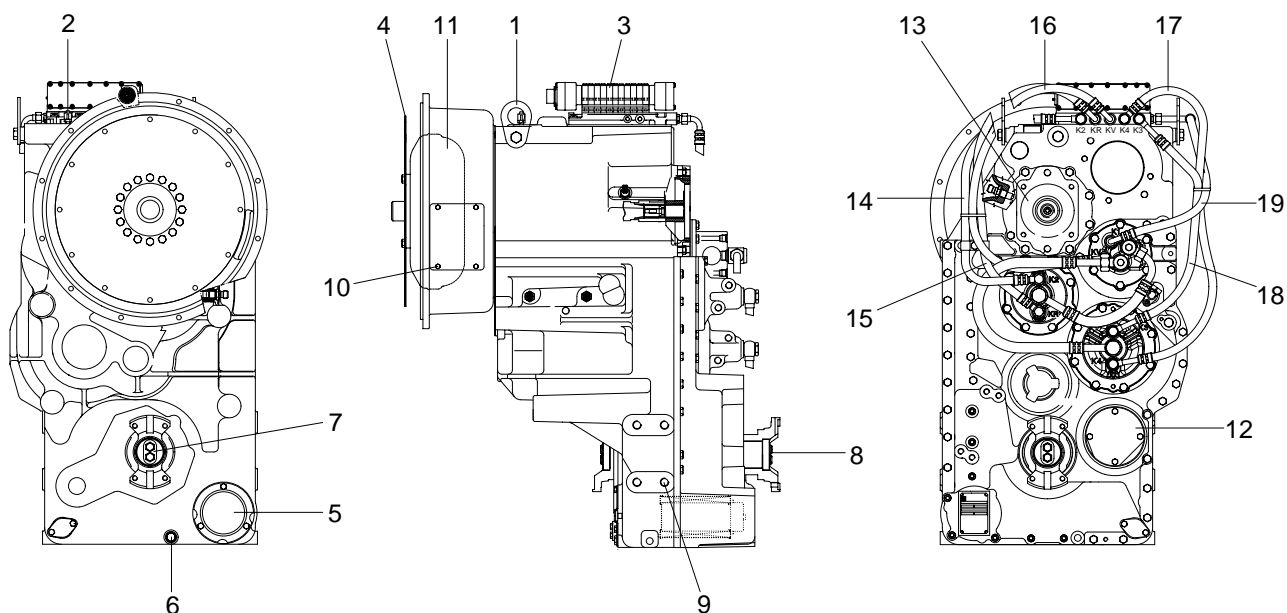

7707PT13

- |    |                                   |    |   |
|----|-----------------------------------|----|---|
| 1  | Lifting lugs                      | 11 | Converter                                   |
| 2  | Breather                          | 12 | Emergency steering pump connection (Option) |
| 3  | Electro-hydraulic shift control   | 13 | Engine driver                               |
| 4  | Engine connection                 | 14 | Pressure line clutch K2                     |
| 5  | Coarse filter                     | 15 | Pressure line clutch KR                     |
| 6  | Oil drain plug M22 × 1.5          | 16 | Pressure line clutch KV                     |
| 7  | Output-rear axle                  | 17 | Pressure line clutch K4                     |
| 8  | Output-front axle                 | 18 | Pressure line clutch K3                     |
| 9  | Transmission suspension holes M20 | 19 | Pressure line clutch K1                     |
| 10 | Mounting holes                    |    |   |

### 3) OPERATION OF TRANSMISSION

#### (1) Forward

##### ① Forward 1st

In 1st forward, forward clutch and 1st clutch are engaged.

Forward clutch and 1st clutch are actuated by the hydraulic pressure applied to the clutch piston.

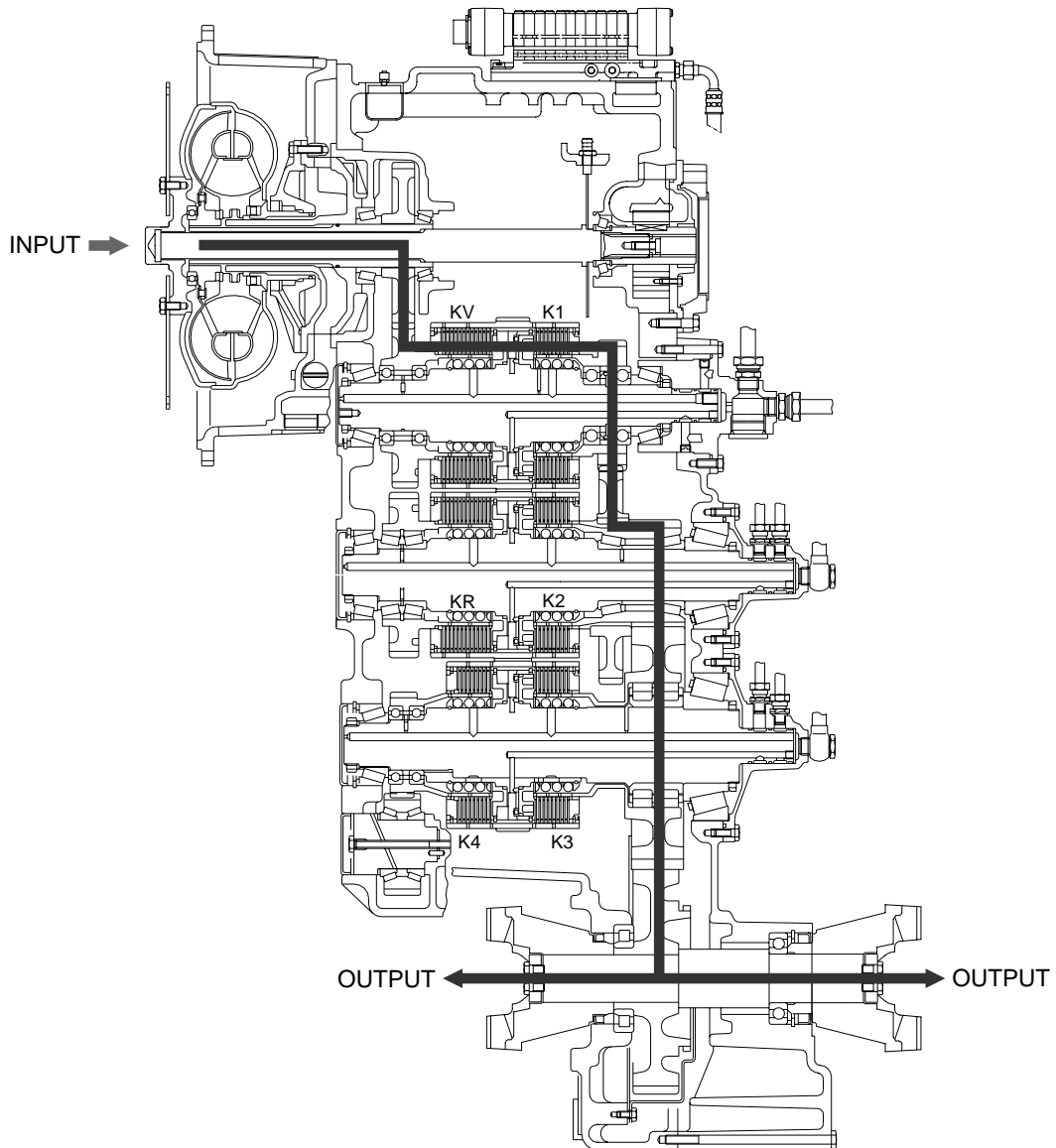

7704PT07



② **Forward 2nd**

In 2nd forward, forward clutch and 2nd clutch are engaged.

Forward clutch and 2nd clutch are actuated by the hydraulic pressure applied to the clutch piston.

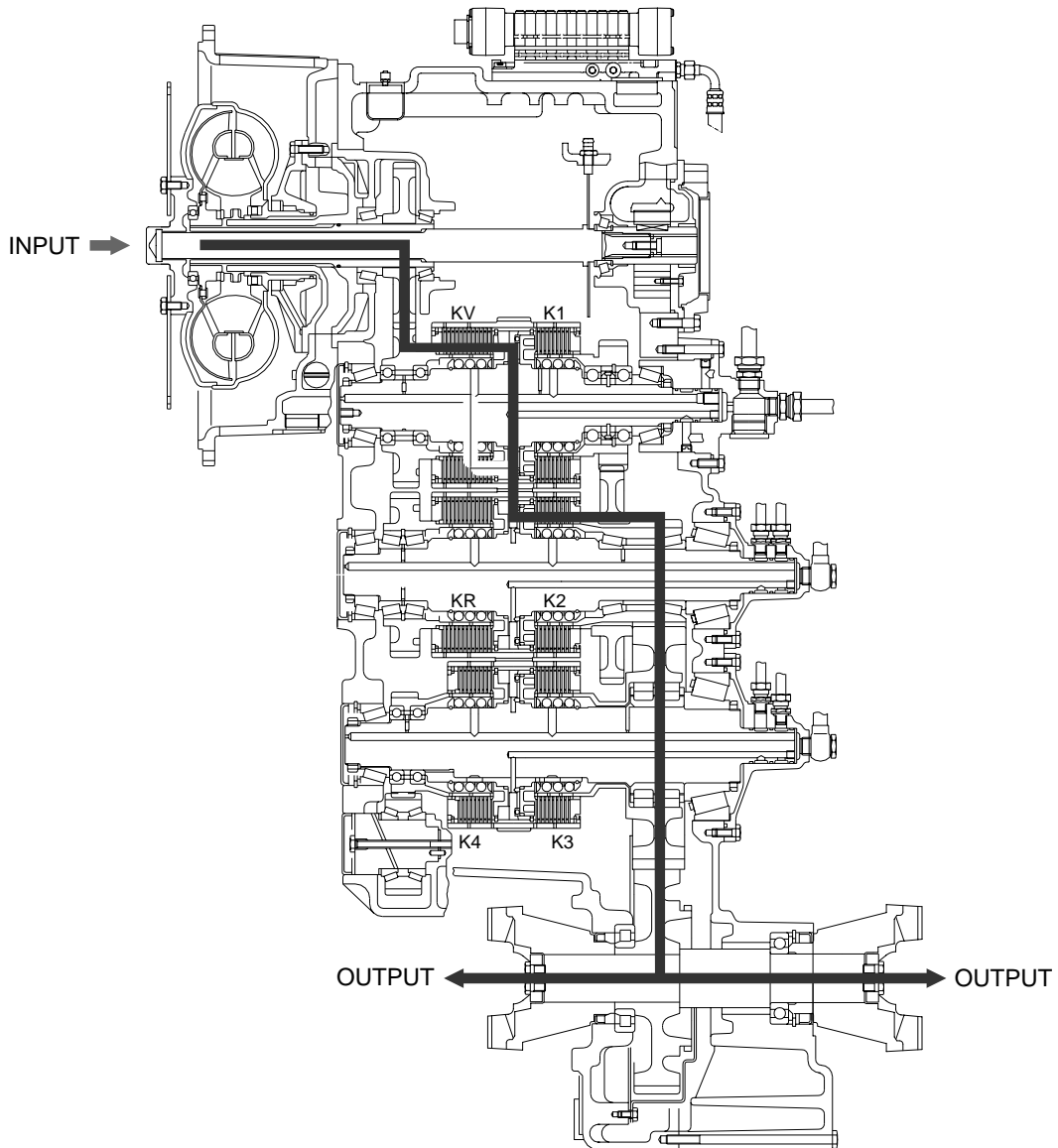

7704PT08

③ **Forward 3rd**

In 3rd forward, forward clutch and 3rd clutch are engage.

Forward clutch and 3rd clutch are actuated by the hydraulic pressure applied to the clutch piston.

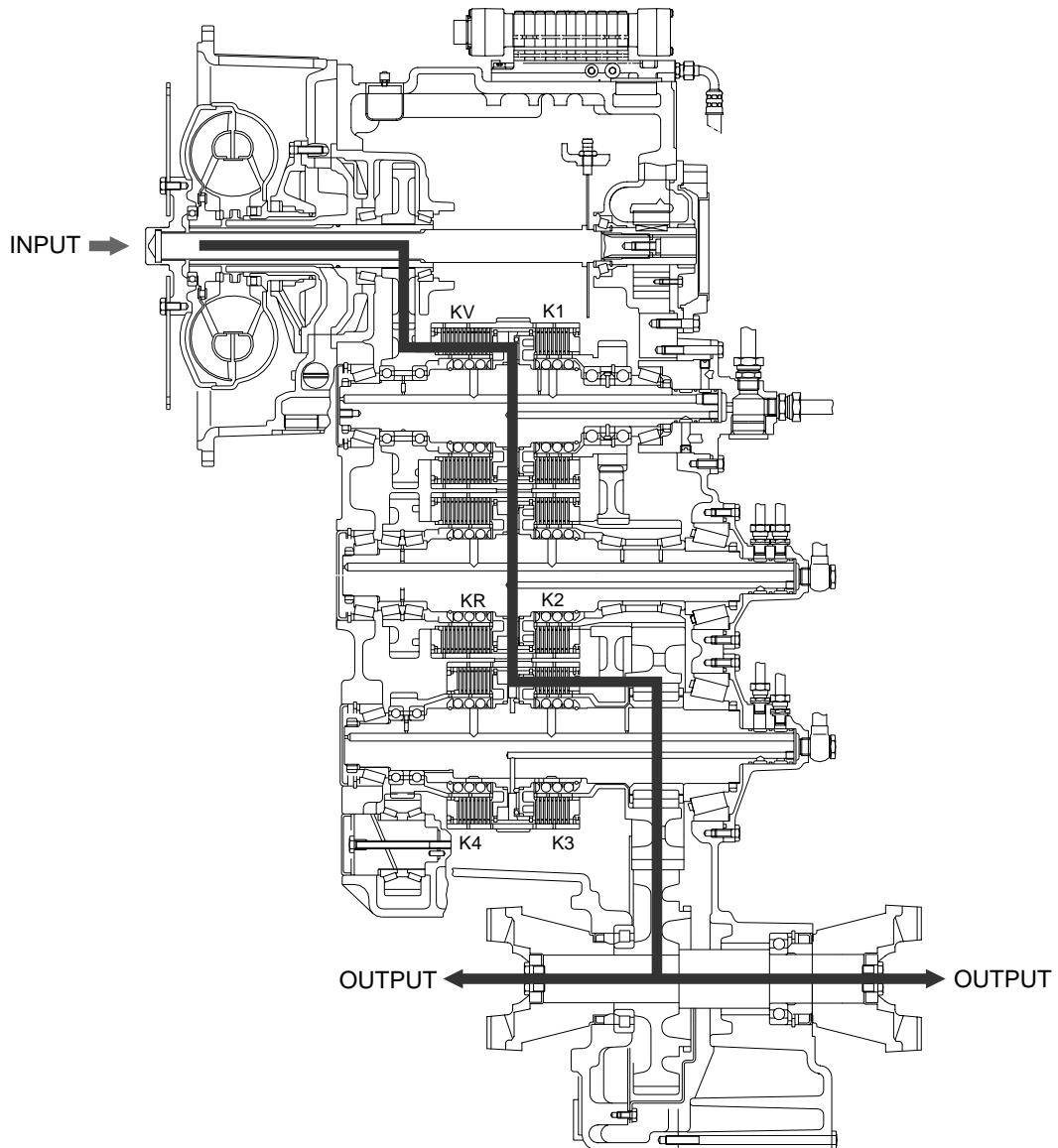

7704PT09

④ **Forward 4th**

In 4th forward, 4th clutch and 3rd clutch are engaged.

4th clutch and 3rd clutch are actuated by the hydraulic pressure applied to the clutch piston.

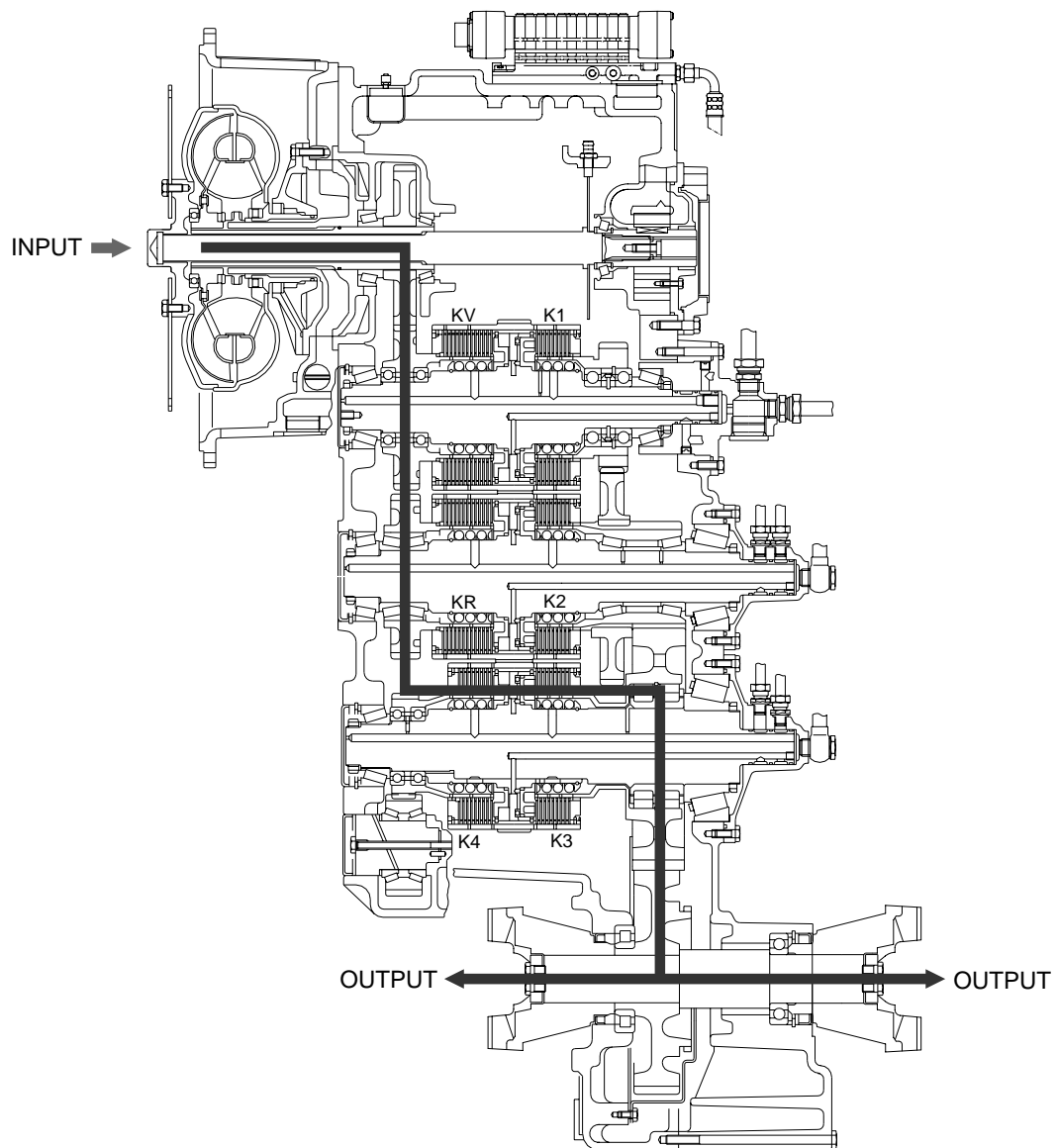

7704PT10

**(2) Reverse**

**① Reverse 1st**

In 1st reverse, reverse clutch and 1st clutch are engaged.

Reverse clutch and 1st clutch are actuated by the hydraulic pressure applied to the clutch piston.

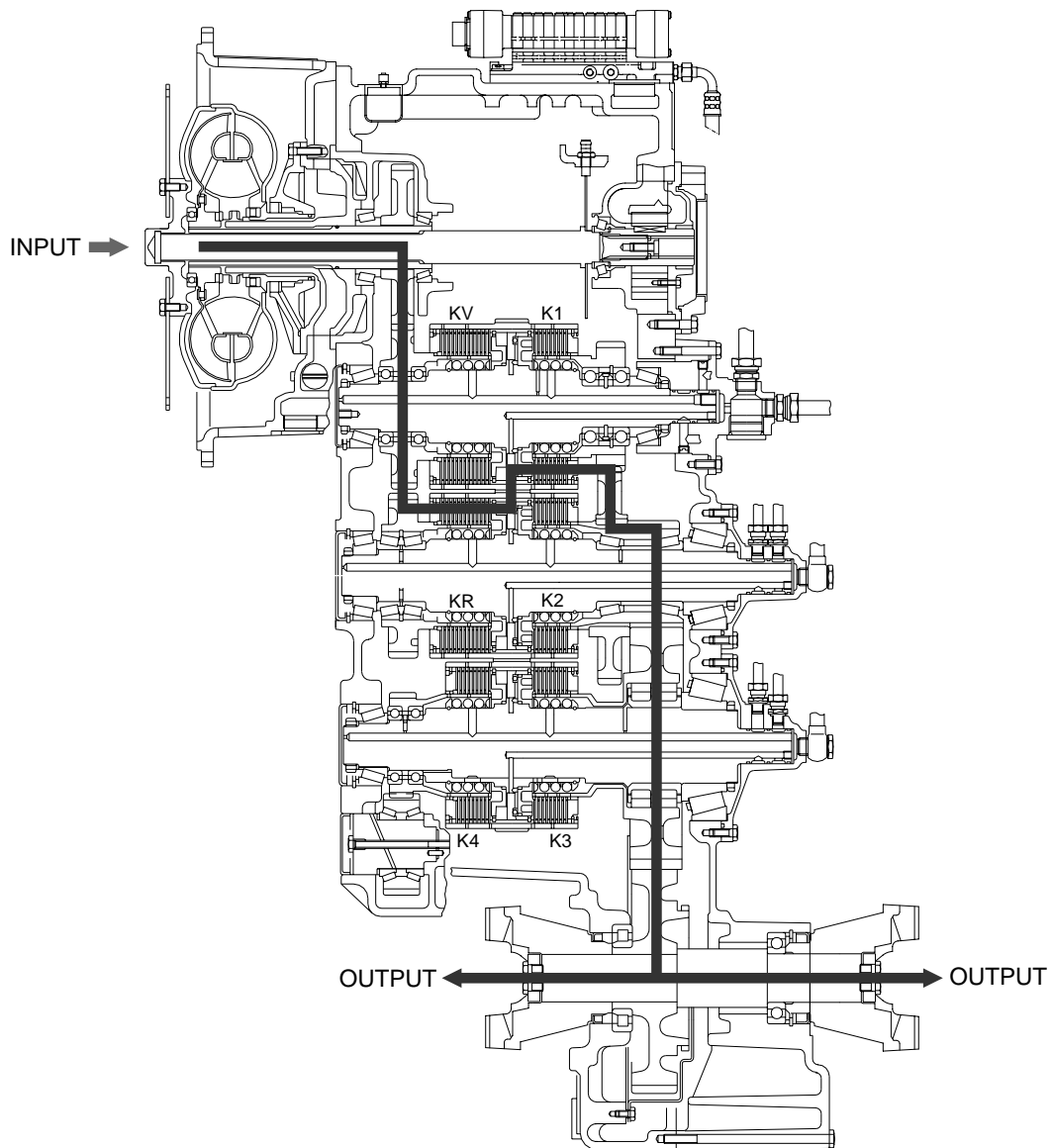

7704PT11

② **Reverse 2nd**

In 2nd reverse, reverse clutch and 2nd clutch are engaged.

Reverse clutch and 2nd clutch are actuated by the hydraulic pressure applied to the clutch piston.

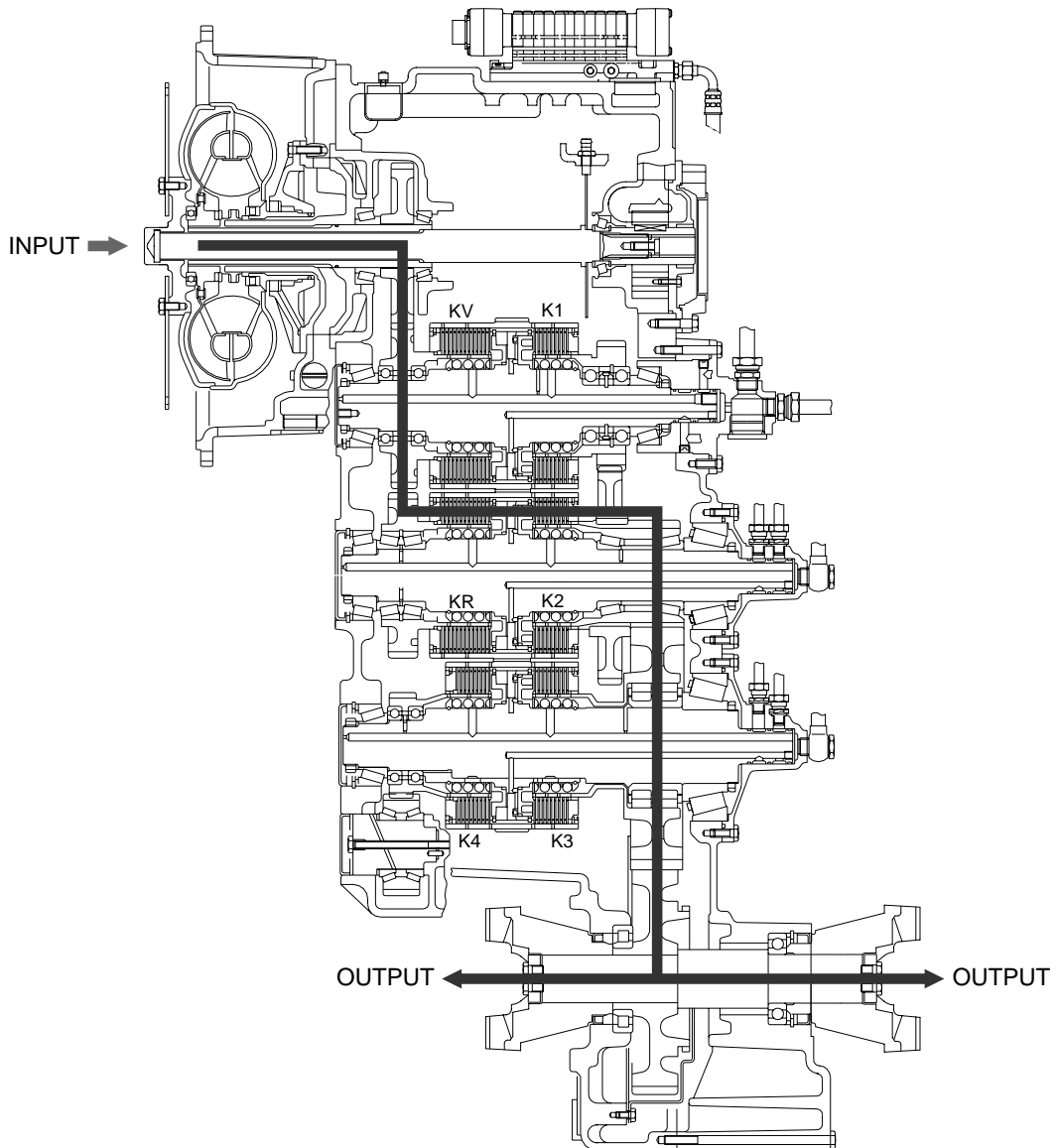

7704PT12

③ Reverse 3rd

In 3rd reverse, reverse clutch and 3rd clutch are engaged.

Reverse clutch and 3rd clutch are actuated by the hydraulic pressure applied to the clutch piston.

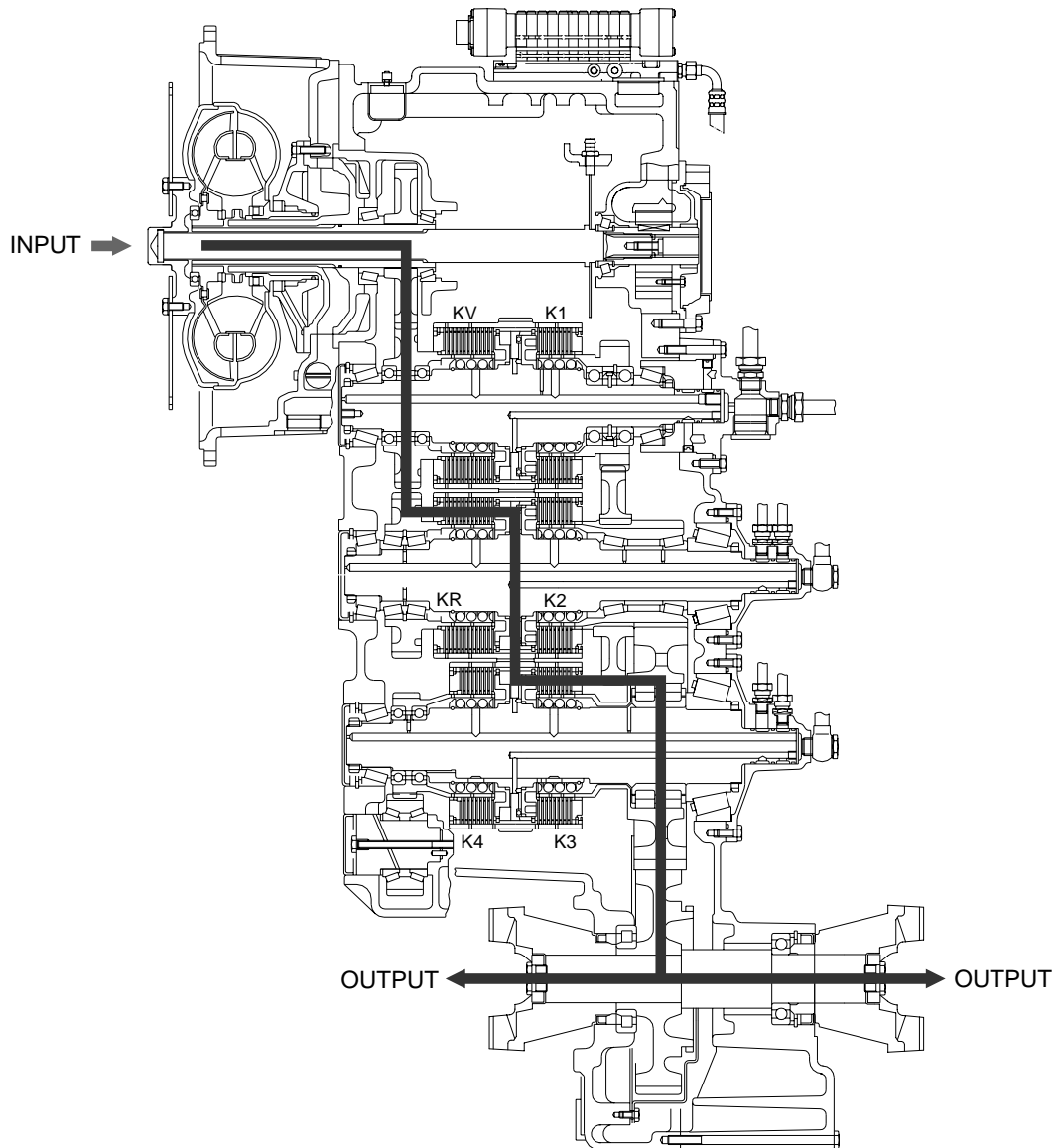

7704PT13

#### 4) ELECTRO-HYDRAULIC SHIFT CONTROL WITH PROPORTIONAL VALVE

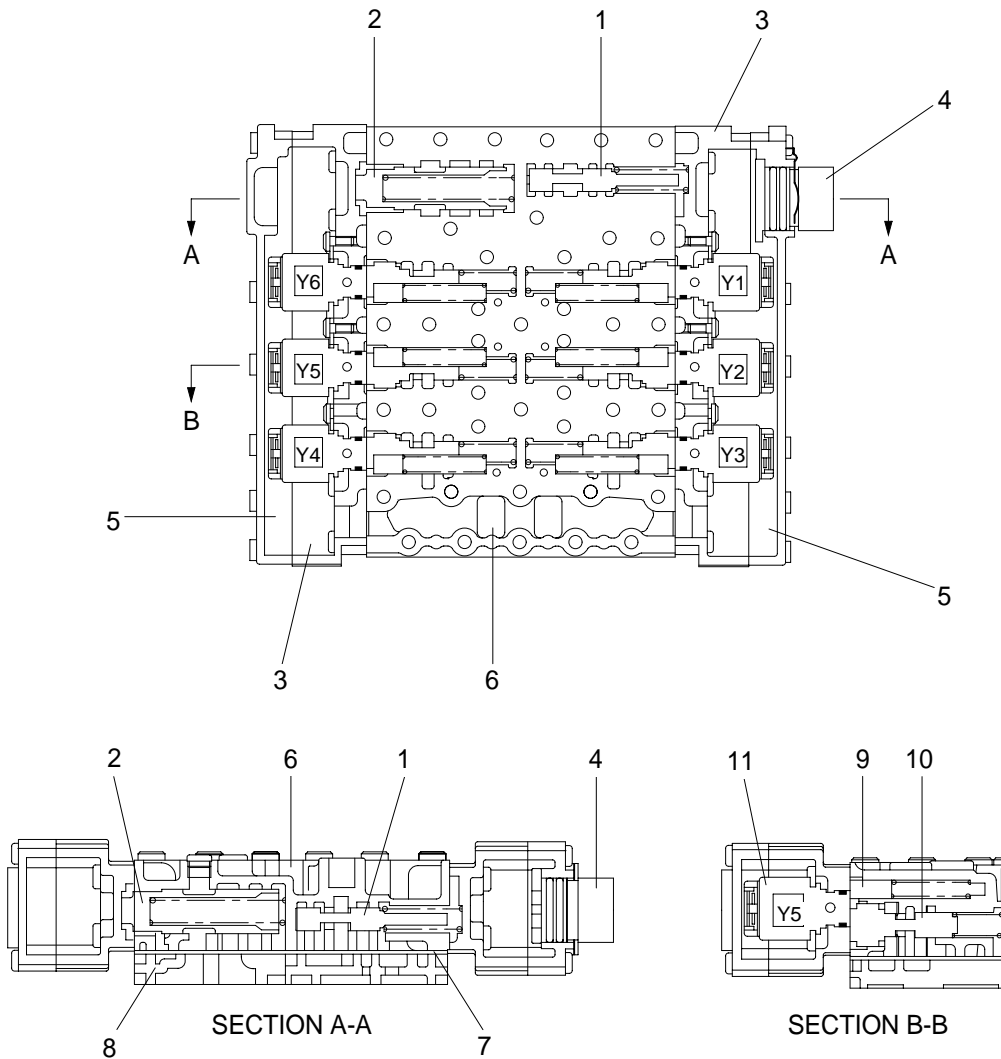

73033CV01

- |   |                                |    |                    |
|---|--------------------------------|----|--------------------|
| 1 | Pressure reducing valve(9bar)  | 7  | Intermediate sheet |
| 2 | System pressure valve(16+2bar) | 8  | Duct plate         |
| 3 | Housing                        | 9  | Oscillation damper |
| 4 | Cable harness                  | 10 | Follow-on slide    |
| 5 | Cover                          | 11 | Pressure regulator |
| 6 | Valve block                    |    |                    |

Transmission control see schedule of measuring points, hydraulic schematic and electro-hydraulic control unit at page 3-2, 3-14 and 3-71.

The six clutches of the transmission are selected through the 6 proportional valves P1 to P6. The proportional valve(Pressure regulator-unit) consists of pressure regulator(e.g. Y1), booster valve oscillation damper.

The pilot pressure of 9 bar for the control of the follow-on slides is created by the reducing valve. The pressure oil (16+2bar) is directed through the follow-on slide to the corresponding clutch.

By the direct proportional selection with separate pressure modulation for each clutch, the pressures to the clutches, taking part in the gear change, are controlled. In this way, a hydraulic overlap of the clutches to be engaged and disengaged is achieved.

This is leading to fast shiftings without traction force interruption.

At the shifting, the following criteria are considered:

- Speed of engine, turbine, central gear train and output.
- Transmission temperature.
- Shifting mode(Up-, down-, reverse shifting and gear engaging from neutral).
- Load level(Full- and partial load, traction, coasting inclusive consideration of load cycles during the shifting).

The system pressure valve is limiting the maximum control pressure to 16+2 bar and releases the main stream to the converter and lubricating circuit.

A converter relief valve is installed in the converter inlet, which protects the converter against high internal pressures(Opening pressure 9bar).

Within the converter, the oil transfers the power transmission according to the well-known hydrodynamic principle(See torque converter, page 3-3).

In order to avoid cavitation, the converter must be always completely filled with oil.

This is achieved by a converter back pressure valve, following the converter, with an opening pressure of about 3.5bar.

The oil, escaping from the converter, is directed to a oil cooler.

The oil is directed from the oil cooler to the transmission and from there to the lubricating-oil circuit so that all lubricating points are supplied with cooled oil.

In the electro-hydraulic control unit there are 6 pressure regulators installed.

## 5) GEAR SELECTOR(DW-3)

The gear selector is designed for the mounting on the left side of the steering column. The positions(Speeds) 1 to 4 are selected by a rotary motion, the driving direction Forward(F)-Neutral(N)-Reverse(R) by tilting the gear selector lever.

The gear selector is also available with integrated kickdown control knob.

A neutral lock is installed as protection against inadvertent drive off.

Position **N** - Gear selector lever blocked in this position.

Position **D** - Driving.

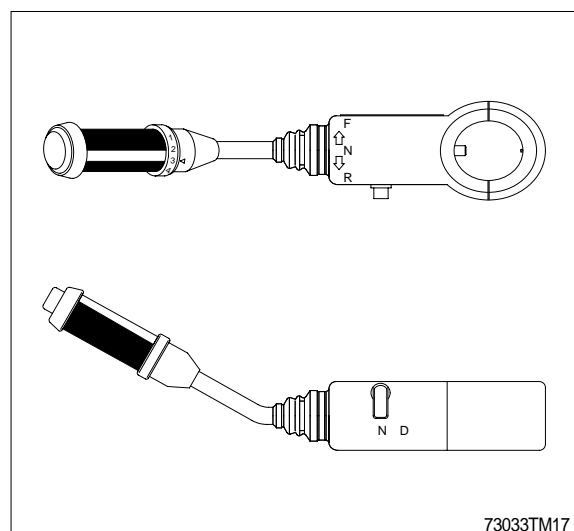



## 6) LCD

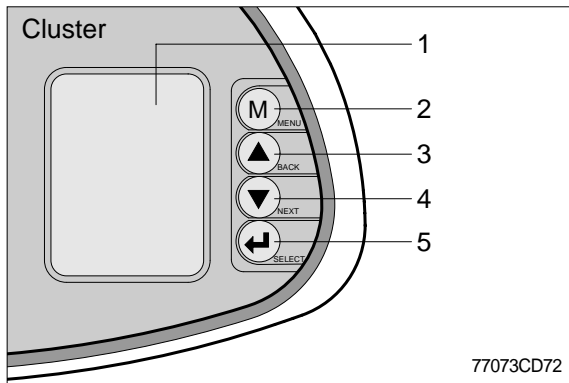

- 1 ( ) LCD
- 2 ( ) MENU
  - Display main menu
  - Return to the normal display
- 3 ( ) BACK
  - Return to the previous menu
- 4 ( ) NEXT
  - Move to the next selection
- 5 ( ) SELECT
  - Activate the currently chosen item

### (1) Normal display

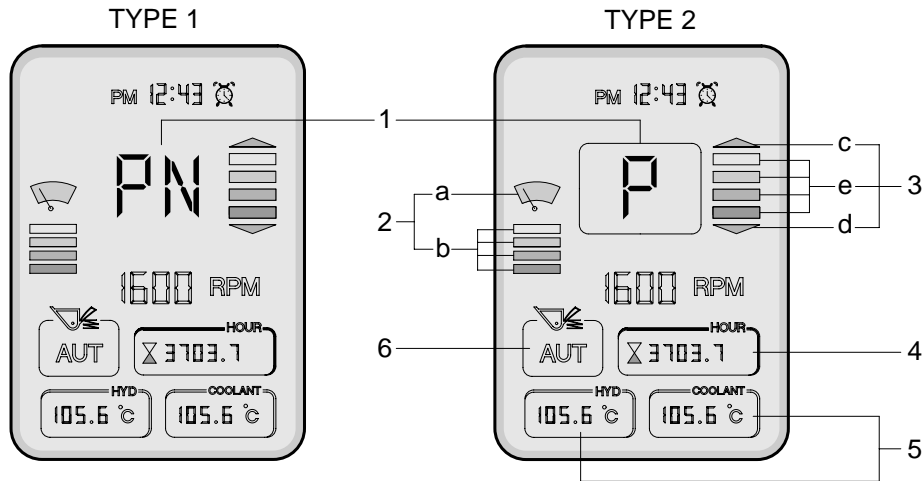

77073CD73

No	Symbol	Meaning	Remark
1		Forward, reverse, neutral	LCD type 1, Display during AEB mode
	F, R, N	Forward, reverse, neutral	LCD type 2, Display during AEB mode
	1, 2, 3, 4	Actual gear	-
	P	Parking brake mode active	-
2	a	Wiper motor intermittently operating	-
	b	When operating intermittently, it shows an operating time interval.	-
3	c, d	Up and down shifting	c : Forward, d : Reverse
	e	Pre-selected gear	-
4		Hour meter	Display the total operation hours of the machine
5		Engine coolant temperature	Display in accordance with selected items
6 (Option)	AUT	Ride control mode active	Ride control switch AUTO position, see page 7-36
	ON	Ride control mode active	Ride control switch ON position, see page 7-36
	OFF	Ride control mode turn off	Ride control switch MIDDLE position, see page 7-36

※ Both type1 and type2 are LCD modes and they can be changed each other by operator's selection.

## (2) Machine fault codes

When selecting the fault code menu, it shows all of the fault codes which mean abnormal conditions of present time.

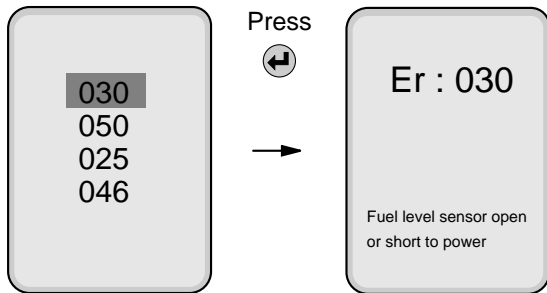

77073CD60

- ※ To go out from fault explanation window, press button.  
(Press , to go out to first menu.)
- ※ **No error** will be indicated in case that there's no fault.

Description	Code	Meaning	Remark
Electrical system	010	Power input voltage low	Below 18V
	011	Power input voltage high	Above 38V
	012	Alternator voltage low	Below 5V
	013	Alternator voltage high	Above 36V
	014	Buzzer circuit open or short to ground	
	015	Buzzer circuit short to power	
Hydraulic system	020	Hydraulic oil temperature sensor open or short to power	
	021	Hydraulic oil temperature sensor short to ground	
Engine system	030	Fuel level sensor open or short to power	
	031	Fuel level sensor short to ground	
	034	Cooling fan driving valve open or short to ground	
	035	Cooling fan driving valve short to power	
T/M system	050	Auto select switch supply power open or short to power	
	051	Auto select switch supply power short to ground	
	052	Clutch cutoff supply power open or short to power	
	053	Clutch cutoff supply power short to ground	
Steering system	060	Emergency steering relay open or short to ground	Option
	061	Emergency steering relay short to power	Option
Communication	070	MCU communication error	
	071	TCU communication error	
	072	ECM communication error	

MCU : Machine control unit TCU : Transmission control unit

ECM : Engine control module

### (3) Display during AEB mode

Symbol	Meaning	Remarks
K1~K4, KV, KR	Calibrating clutch K1~K4, KV or KR respectively	
- And Kx	Wait for start, initialization of clutch Kx, x : 1, 2, 3, 4, V, R	
And Kx	Fast fill time determination of clutch Kx	
= And Kx	Compensating pressure determination of clutch Kx	
OK	Calibration for all clutches finished	Transmission stays in neutral, you have to restart the TCU(Ignition off/on) after removing AEB-Starter
STOP	AEB canceled(Activation stopped)	Transmission stays in neutral, you have to restart the TCU(Ignition off/on)
STOP and Kx	AEB stopped, clutch Kx can't be calibrated	Transmission stays in neutral, you have to restart the TCU(Ignition off/on)
Spanner and Kx	Kx couldn't be calibrated, AEB finished	Transmission stays in neutral, you have to restart the TCU(Ignition off/on)
△E	Engine speed too low, - Raise engine speed	
▽E	Engine speed too high, - Lower engine speed	
△T	Transmission oil temperature too low, - Heat up transmission	
▽T	Transmission oil temperature too high, - Cool down transmission	
FT	Transmission temperature not in defined range during calibration	Transmission stays in neutral, you have to restart the TCU(Ignition off/on)
FB	Operating mode not NORMAL or transmission temperature sensor defective or storing of calibrated values to EEPROM has failed	Transmission stays in neutral, you have to restart the TCU(Ignition off/on)
FO	Output speed not zero	Transmission stays in neutral, you have to restart the TCU(Ignition off/on)
FN	Shift lever not in neutral position	Transmission stays in neutral, you have to restart the TCU(Ignition off/on)
FP	Park brake not applied	Transmission stays in neutral, you have to restart the TCU(Ignition off/on)
STOP	AEB-Starter was used incorrect or is defective. Wrong device or wrong cable used	Transmission stays in neutral, you have to restart the TCU(Ignition off/on)

※ **AEB mode** : It controls the disk internal of the transmission, automatically.

Refer to page 7-29, 30.

#### (4) Engine fault codes

Fault code No.	Reason	Effect(only when fault code is active)
111	ECM internal hardware error.	Possible no effect or engine may run rough or not start.
115	No engine speed or position signal detected at pin 17 of the engine harness.	Engine power derate. Possible white smoke.
121	No engine speed or position signal detected at pin 9 of the engine harness	No engine speed and position backup for main speed/position sensor.
122	High voltage detected at the boost pressure sensor signal pin 45 of the engine harness.	Engine will derate to no-boost fueling.
123	Low voltage detected at boost pressure sensor signal pin 45 of the engine harness.	Engine will derate to no-boost fueling.
131	High voltage detected at throttle position signal pin 30 of the machine harness.	Engine idles when idle validation switch indicates idle and ramps up to a default set speed when the idle validation switch indicates off-idle.
132	Low voltage detected at throttle position signal pin 30 of the machine harness.	Engine idles when idle validation switch indicates idle and ramps up to a default set speed when the idle validation switch indicates off-idle.
133	High voltage detected at remote throttle position signal pin 9 of the machine harness.	Engine will <b>not</b> respond to remote throttle input.
134	Low voltage detected at remote throttle position signal pin 9 of the machine harness.	Engine will <b>not</b> respond to remote throttle input.
135	High voltage detected at oil pressure signal pin 33 of the engine harness.	Default value used for oil pressure. No engine protection for oil pressure.
141	Low voltage detected at oil pressure signal pin 33 of the engine harness.	Default value used for oil pressure. No engine protection for oil pressure.
143	Oil pressure signal indicates oil pressure below the low engine protection limit.	Power and/or speed derate and possible engine shutdown if engine protection shutdown feature is enabled.
144	High voltage detected at coolant temperature signal pin 23 of the engine harness.	Default value used for coolant temperature. No engine protection for coolant temperature.
145	Low voltage detected at coolant temperature signal pin 23 of the engine harness.	Default value used for coolant temperature. No engine protection for coolant temperature.
146	Coolant temperature signal indicates coolant temperature has exceeded the minimum engine protection limit.	Power derate and possible engine shutdown if engine protection shutdown feature is enabled.
147	A frequency below a calibrated value has been detected at the frequency throttle signal pin 4 of the engine harness.	Engine will <b>not</b> respond to changes in frequency throttle. Engine will go to low idle.
148	A frequency below a calibrated value has been detected at the frequency throttle signal pin 4 of the engine harness.	Engine will <b>not</b> respond to changes in frequency throttle. Engine will go to low idle.
151	Coolant temperature signal indicates coolant temperature has exceeded the maximum engine protection limit.	Speed derate and possible engine shutdown if engine protection shutdown feature is enabled.
153	High voltage detected at intake manifold temperature signal pin 34 of the engine harness.	Default value used for intake manifold temperature. No engine protection for intake manifold temperature.
154	Low voltage detected at intake manifold temperature signal pin 34 of the engine harness.	Default value used for intake manifold temperature. No engine protection for intake manifold temperature.
155	Intake manifold air temperature signal indicates intake manifold air temperature is above the maximum engine protection limit.	Speed derate and possible engine shutdown if engine protection shutdown feature is enabled.
184	Error detected in the control synchronization of multiple engines.	Multiple unit synchronization will be disable. Engine will only idle.
191	Air conditioner clutch driver signal indicates a short to ground when commanded on.	Air conditioner clutch will <b>not</b> operate.

Fault code No.	Reason	Effect(only when fault code is active)
211	Machine specific fault code has occurred.	No effect on engine performance.
221	High voltage detected at ambient air pressure signal pin 32 of the engine harness.	Engine power derate.
222	Low voltage detected at ambient air pressure signal pin 32 of the engine harness.	Engine power derate.
234	Engine speed signal indicates engine speed has exceeded the overspeed limit.	Fuel to injectors disabled until engine speed falls below the overspeed limit.
235	Coolant level signal at pin 37 of the engine harness indicates coolant level is low.	Power and/or speed derate and possible engine shutdown if engine protection shutdown feature is enabled.
241	Vehicle speed signal on pins 8 and 18 of the machine harness has been lost.	EEngine speed limited to "Max. Engine Speed without VSS". Cruise control, gear-down protection and the road speed governor will <b>not</b> work. Trip information data that is based on mileage will be incorrect.
242	Possible tampering has been detected on the vehicle speed circuit pins 8 and 18 of the machine harness	Engine speed limited to " Max. Engine Speed without VSS". Cruise control, gear-down protection and the road speed governor will <b>not</b> work. Trip information data that is based on mileage will be incorrect.
243	Error detected in the exhaust brake relay enable circuit at pin 42 of the engine harness.	Exhaust brake will <b>not</b> work.
245	Error detected in fan clutch relay enable circuit at pin 41 of the engine harness.	Electronic control; module(ECM) can <b>not</b> control the engine cooling fan. Fan will remain on or off.
263	High voltage detected at the fuel temperature sensor signal pin 35 of the engine harness.	Default value used for fuel temperature. Possible low power.
265	Low voltage detected at the fuel temperature sensor signal pin 35 of the engine harness.	Default value used for fuel temperature. Possible low power.
268	Fuel pressure in the accumulator is <b>not</b> changing with engine operating conditions.	Power derate. Engine may run rough.
271	Low or no current detected on front pumping control valve return pin 21.(Set only during control valve click test)	Low power or poor performance.
272	High current detected on front pumping control valve return pin 21.	Low power or poor performance. Possible damage to the ECM.
273	Low or no current detected on rear pumping control valve return pin 15.(Set only during control valve click test)	Low power or poor performance.
274	High current detected on rear pumping control valve return pin 15.	Low power or poor performance. Possible damage to the ECM.
275	Engine ECM has detected a failure in the front pumping element.	Low power or poor performance.
276	High current detected on injection control valve return pin 7.	Injection Control Valve is shutdown and engine will <b>not</b> run. Possible ECM damage.
277	Engine ECM has detected a failure in the injection control valve.	Low power. Engine may <b>not</b> run.
278	Error detected in lift pump circuit at pin 11 of the engine harness.	Possible low power, engine may die, run rough or be difficult to start.
279	Low or no current detected on injection control valve return pin 7.(Set only during control valve click test)	Low power. Engine may <b>not</b> run.
281	Engine ECM has detected a failure in the front pumping element.	Possible no effect or engine power derate.
282	Engine ECM has detected a failure in the rear pumping element.	Possible no effect or engine power derate.

Fault code No.	Reason	Effect(only when fault code is active)
283	High voltage detected at main engine speed/ position sensor voltage supply pin 8 of the engine harness.	ECM will use the engine position signal as a backup. Possible white smoke and power loss.
284	Low voltage detected at main engine speed/ position sensor voltage supply pin 8 of the engine harness.	ECM will use the engine position signal as a backup. Possible white smoke and power loss.
285	The ECM expected information from a multiplexed device but did not receive it soon enough or did not receive it at all.	At least one multiplexed device will not operate properly.
286	The ECM expected info from a multiplexed device but only received a portion of the necessary information	At least on multiplexed device will not operate properly.
287	The machine vehicle electronic control unit (VECU) detected a fault with its throttle pedal.	The engine will only idle.
288	The machine vehicle electronic control unit (VECU) detected a fault with its remote throttle.	The engine will not respond to the remote throttle.
296	OEM pressure signal at pin 48 of the OEM harness indicates pressure outside the engine protection limit.	Speed derate and possible engine shutdown if engine protection shutdown feature is enabled.
297	High voltage detected at machine pressure signal pin 48 of the machine harness.	Default value used for machine pressure. Lose ability to control machine pressure.
298	Low voltage detected at machine pressure signal pin 48 of the machine harness.	Default value used for machine pressure. Lose ability to control machine pressure.
299	Engine shutdown by device other than key switch before proper engine cool down resulting in filtered load factor above maximum shutdown threshold.	No action taken by the ECM.
319	Power to the real time clock has been interrupted and its setting is no longer valid	Time stamp in ECM powerdown data will be incorrect.
328	Engine ECM has detected a failure in the rear pumping element.	Low power. Engine may <b>not</b> run.
329	Engine ECM has detected an overpumping failure in the CAPS pump.	Engine power derate, engine may die.
349	Auxiliary speed signal frequency indicates the frequency is above a calibrated threshold value.	Engine will go to idle and lose ability to control speed of the auxiliary device.
352	Low voltage detected at engine position sensor +5 VDC supply, pin 10 of the engine harness.	Default value used for sensors connected to this +5 VDC supply. Engine will derate to no-boost fueling and loss of engine protection for oil pressure, intake manifold pressure, and ambient air pressure.
381	Error detected in cold start aid relay 1 enable circuit at pin 41 of the machine harness.	Intake air heater can not be fully energized by the ECM. Possible white smoke and/or hard starting.
382	Error detected in cold start aid relay 2 enable circuit at pin 31 of the machine harness.	Intake air heater can <b>not</b> be fully energized by the ECM. Possible white smoke and/or hard starting.
385	High voltage detected at machine harness sensor +5 VDC supply pin 10 of the machine harness.	Sensors connected to this +5 VDC supply(i.e. remote throttle position sensor) will <b>not</b> function.
386	High voltage detected at the engine harness sensor +5 VDC supply pin 10 of the engine harness.	Default value used for sensors connected to this +5 volts supply. Engine will derate to no-boost fueling and loss of engine protection for oil pressure, intake manifold temperature, and coolant temperature.
387	High voltage detected at the throttle position sensor +5 VDC supply pin 29 of the machine harness.	Engine idles when idle validation switch indicates idle and ramps up to a default set speed when idle validation switch indicates off-idle.

Fault code No.	Reason	Effect(only when fault code is active)
415	Oil pressure signal indicates oil pressure elow the very low engine protection limit.	Speed derate and possible engine shutdown if engine protection shutdown feature is enagled.
418	Water-in-fuel signal indicates the water in the fuel filter needs to be drained.	Excessive water in the fuel can lead to severe fuel sysm damage.
422	Voltage detected simultaneously on both the coolant level high and low signal pins 27 and 37 of the engine harness or no voltage detected on either pin.(Fault is active for switch type coolant level sensors only)	No engine protection for coolant level.
429	Low voltage detected at water-in-fuel signal pin 40 of the machine harness.	No water-in-fuel protection.
431	Idle validation signals on pins 25 and 26 of the machine harness indicate voltage detected simultaneously on both pins or no voltage detected on either pin.	No effect on performance, but loss of idle validation.
432	Idle validation signal at pin 26 of the machine harness indicates the throttle is at the idle position when the throttle position signal at pin 30 of the machine harness indicates the throttle is <b>not</b> at the idle position...OR...idle validation signal at pin 26 of the machine harness indicates the throttle is <b>not</b> at the idle position when the throttle position signal at pin 30 of the machine harness indicates the throttle is at the idle position.	Engine will only idle.
433	Boost pressure signal indicates boost pressure is high when other engine parameters(i.e. speed and load) indicate boost pressure should be low...OR...boost pressure is low when other engine parameters indicate it should be high.	Possible overfueling during acceleration. Increase in black smoke.
434	All data gathered by the ECM since the last key on(i.e.faults, trip information data. etc.)was <b>not</b> stored to permanent memory at the last key off.	None on performance. Fault code table, trip information data, maintenance monitor data, trending data and user activated datalogger data may be inaccurate.
441	Voltage detected at ECM power supply pins 38, 39, 40 and 50 of the engine harness indicates the ECM supply voltage fell below 6 VDC.	Engine will die or run rough.
442	Voltage detected at ECM power supply pins 38, 39, 40 and 50 of the engine harness indicates the ECM supply voltage is above the maximum system voltage level.	None on performance.
443	Low voltage detected at throttle position sensor +5 VDC supply pin 29 of the machine harness.	Engine idles when idle validation switch indicates idle and ramps up to a default set speed when idle validation switch indicates off-idle.
444	Low voltage detected at machine harness sensor +5 VDC supply pin 10 of the machine harness.	Sensors connected to this +5 VDC supply (i.e. remote throttle position sensor) will <b>not</b> function.
449	Fuel pressure signal indicates that fuel pressure has exceeded the maximum limit for the given engine rating.	Fuel pumping is stopped until pressure returns to normal. Possible fuel pump damage may result.
451	High voltage detected at fuel pressure sensor signal pin 46 of the engine harness.	Low power, reduced performance.
452	Low voltage detected at fuel pressure sensor signal pin 46 of the engine harness.	Low power, reduced performance.
456	Fuel pressure in the accumulator is not changing with engine operating conditions.	Power and/or speed derate; engine will possibly run rough.

Fault code No.	Reason	Effect(only when fault code is active)
488	Intake manifold temperature signal indicates intake manifold temperature is above the minimum engine protection limit.	Power derate and possible engine shutdown if engine protection shutdown feature is enabled.
489	Auxiliary device speed signal on pins 8 and 18 of the OEM harness is out of range of the ECM threshold.	Lose ability to control the speed of the auxiliary device.
493	ECM has detected a circuit failure on the injection control valve certifier circuit.	Slight loww of performance.
497	Error detected in the multiple unit synchronization control switch input, pins 24 and 38 of the OEM harness.	Multiple unit synchronization feature will be disabled.
515	High voltage detected at the auxiliary +5 VDC sensor supply voltage pin 49 of the engine harness.	Auxiliary device will <b>not</b> function.
516	Low voltage detected at the auxiliary +5 VDC sensor supply voltage pin 49 of the engine harness.	Auxiliary device will not function.
524	Error detected on the high speed governor droop selection switch in put pin 24 of the engine harness.	Operator can not select alternate high speed governor droop. Normal droop is used.
527	Error detected in the dual output driver "A" circuit pin 5 of the machine harness.	The device being controlled by the dual output driver "A" signal will <b>not</b> function properly.
528	Error detected on the torque curve selection switch input pin 39 of the machine harness.	Operator can not select alternate torque curves. Normal torque curve is used.
529	Error detected in the dual output driver "B" circuit pin 1 of the engine harness.	The device being controlled by the dual output driver "B" signal will <b>not</b> function properly.
539	Open circuit failure of the injection control valve transorb pin 6 of the engine harness.	Low power, possible ECM damage.
551	Idle validation signals on pins 25 and 26 of the machine harness indicate voltage detected simultaneously on both pins.	Engine will only idle.
599	Software has initiated an engine shutdown based on machine sensor inputs	Engine will shutdown.
768	Error detected in the output device driver(VGT or transmission shift modulation signal) signal pin 21 of the machine harness.	Can not control the VGT or transmission, depending on application.
779	OEM switch signal at pin 16 of the engine harness indicates engine protection condition.	Power derate and possible engine shutdown if engine protection shutdown feature is enabled.

※ Some fault codes are not applied to this machine.



## **(5) DEFINITION OF OPERATING MODES**

### **① Normal**

There's no failure detected in the transmission system or the failure has no or slight effects on transmission control. TCU will work without or in special cases with little limitations.(See following table)

### **② Substitute clutch control**

TCU can't change the gears or the direction under the control of the normal clutch modulation. TCU uses the substitute strategy for clutch control. All modulations are only time controlled. (Comparable with EST 25)

### **③ Limp-home**

The detected failure in the system has strong limitations to transmission control. TCU can engage only one gear in each direction. In some cases only one direction will be possible. TCU will shift the transmission into neutral at the first occurrence of the failure. First, the operator must shift the gear selector into neutral position.

If output speed is less than a threshold for neutral to gear and the operator shifts the gear selector into forward or reverse, the TCU will select the limp-home gear.

If output speed is less than a threshold for reversal speed and TCU has changed into the limp-home gear and the operator selects a shuttle shift, TCU will shift immediately into the limp-home gear of the selected direction.

If output speed is greater than the threshold, TCU will shift the transmission into neutral. The operator has to slow down the vehicle and must shift the gear selector into neutral position.

### **④ Transmission-shutdown**

TCU has detected a severe failure that disables control of the transmission.

TCU will shut off the solenoid valves for the clutches and also the common power supply(VPS1).

Transmission shifts to neutral. The park brake will operate normally, also the other functions which use ADM1 to ADM8.

The operator has to slow down the vehicle. The transmission will stay in neutral.

### **⑤ TCU-shutdown**

TCU has detected a severe failure that disables control of system.

TCU will shut off all solenoid valves and also both common power supplies(VPS1, VPS2). The park brake will engage, also functions are disabled which use ADM 1 to ADM 8.

The transmission will stay in neutral.

### **※ Abbreviations**

OC : Open circuit

SC : Short circuit

OP mode : Operating mode

TCU : Transmission control unit

EEC : Electronic engine controller

PTO : Power take off

## (6) Transmission fault codes

Fault code (Hex)	Int. code (Dec)	Meaning of the fault code possible reason for fault detection	Reaction of the TCU	Possible steps to repair	Remarks
11	48	<b>Logical error at gear range signal</b> TCU detected a wrong signal combination for the gear range Cable from shift lever to TCU is broken Cable is defective and is contacted to battery voltage or vehicle ground Shift lever is defective	TCU shifts transmission to neutral OP-mode : Transmission shutdown	Check the cables from TCU to shift lever Check signal combinations of shift lever positions for gear range	Failure cannot be detected in systems with DW2/DW3 shift lever Fault is taken back if TCU detects a valid signal for the position
12	46	<b>Logical error at direction select signal</b> TCU detected a wrong signal combination for the direction Cable from shift lever to TCU is broken Cable is defective and is contacted to battery voltage or vehicle ground Shift lever is defective	TCU shifts transmission to neutral  OP-Mode : Transmission shutdown	Check the cables from TCU to shift lever  Check signal combinations of shift lever positions F-N-R	Fault is taken back if TCU detects a valid signal for the direction at the shift lever
13	95	<b>Logical error at engine derating device</b> TCU detected no reaction of engine while derating device active	After selecting neutral, TCU change to OP mode limp home	Check engine derating device	This fault is reset after power up of TCU
15	176	Logical error at direction select signal 2 shift lever TCU detected a wrong signal combination for the direction Cable from shift lever 2 to TCU is broken Cable is defective and is contacted to battery voltage or vehicle ground Shift lever is defective	TCU shifts transmission to neutral if selector active OP mode : Transmission shutdown if selector active	Check the cables from TCU to shift lever 2 Check signal combinations of shift lever positions F-N-R	Fault is taken back if TCU detects a valid neutral signal for the direction at the shift lever
16	178	<b>Logical error at axle connection</b> Feedback axle connection measured by TCU and output signal axle connection don't fit Axle can't be connected or disconnected due to mechanical problem One of the cables from feedback axle connection switch to TCU is broken	OP mode : Normal	Check the cables from TCU to feedback axle connection switch Check signals of the feedback axle connection switch	

Fault code (Hex)	Int. code (Dec)	Meaning of the fault code possible reason for fault detection	Reaction of the TCU	Possible steps to repair	Remarks
21	32	<b>S.C. to battery voltage at clutch cut off input</b> The measured voltage is too high: Cable is defective and is contacted to battery voltage Clutch cut off sensor has an internal defect Connector pin is contacted to battery voltage	Clutch cut off function is disabled OP mode : Normal	Check the cable from TCU to the sensor Check the connectors Check the clutch cut off sensor	
22	29	<b>S.C. to ground or O.C. at clutch cut off input</b> The measured voltage is too low: Cable is defective and is contacted to vehicle ground Cable has no connection to TCU Clutch cut off sensor has an internal defect Connector pin is contacted to vehicle ground or is broken	Clutch cut off function is disabled OP mode : Normal	Check the cable from TCU to the sensor Check the connectors Check the clutch cut off sensor	
23		<b>S.C. to battery voltage at load sensor input</b> The measured voltage is too high: Cable is defective and is contacted to battery voltage Load sensor has an internal defect Connector pin is contacted to battery voltage	Retarder function is affected TCU uses default load OP mode : Normal	Check the cable from TCU to the sensor Check the connectors Check the load sensor Check the assembly tolerances of load sensor	Availability of retarder depends on default load
24		<b>S.C. to ground or O.C. at load sensor input</b> The measured voltage is too low: Cable is defective and is contacted to vehicle ground Cable has no connection to TCU Load sensor has as internal defect Connector pin is contacted to vehicle ground or is broken	Retarder function is affected TCU use default load OP mode : Normal	Check the cable from TCU to the sensor Check the connectors Check the load sensor Check the assembly tolerances of load sensor	Availability of retarder depends on default load

Fault code (Hex)	Int. code (Dec)	Meaning of the fault code possible reason for fault detection	Reaction of the TCU	Possible steps to repair	Remarks
25	33	<b>S.C. to battery voltage or O.C. at transmission sump temperature sensor input</b> The measured voltage is too high: Cable is defective and is contacted to battery voltage Cable has no connection to TCU Temperature sensor has an internal defect Connector pin is contacted to battery voltage or is broken	No reaction, TCU use default temperature OP mode : Normal	Check the cable from TCU to the sensor Check the connectors Check the temperature sensor	
26	30	<b>S.C. to battery voltage or O.C. at transmission sump temperature sensor input</b> The measured voltage is too low: Cable is defective and is contacted to vehicle ground Temperature sensor has an internal defect Connector pin is contacted to vehicle ground	No reaction, TCU uses default temperature OP mode : Normal	Check the cable from TCU to the sensor Check the connectors Check the temperature sensor	
27	76	<b>S.C. to battery voltage or O.C. at retarder temperature sensor input</b> The measured voltage is too high: Cable is defective and is contacted to battery voltage Cable has no connection to TCU Temperature sensor has an internal defect Connector pin is contacted to battery voltage or is broken	No reaction, TCU uses default temperature OP mode : Normal	Check the cable from TCU to the sensor Check the connectors Check the temperature sensor	
28	74	<b>S.C. to ground at retarder temperature sensor input</b> The measured voltage is too low: Cable is defective and is contacted to vehicle ground Temperature sensor has an internal defect Connector pin is contacted to vehicle ground	No reaction, TCU uses default temperature OP mode : Normal	Check the cable from TCU to the sensor Check the connectors Check the temperature sensor	

Fault code (Hex)	Int. code (Dec)	Meaning of the fault code possible reason for fault detection	Reaction of the TCU	Possible steps to repair	Remarks
27	76	<b>S.C. to battery voltage or O.C. at converter output temperature sensor input</b> The measured voltage is too high: Cable is defective and is contacted to battery voltage Cable has no connection to TCU Temperature sensor has an internal defect Connector pin is contacted to battery voltage or is broken	No reaction, TCU uses default temperature OP mode : Normal	Check the cable from TCU to the sensor Check the connectors Check the temperature sensor	
28	74	<b>S.C. to ground at converter output temperature sensor input</b> The measured voltage is too low: Cable is defective and is contacted to vehicle ground Temperature sensor has an internal defect Connector pin is contacted to vehicle ground	No reaction, TCU uses default temperature OP mode : Normal	Check the cable from TCU to the sensor Check the connectors Check the temperature sensor	
31	38	<b>S.C. to battery voltage or O.C. at engine speed input</b> TCU measures a voltage higher than 7.00V at speed input pin Cable is defective and is contacted to battery voltage Cable has no connection to TCU Speed sensor has an internal defect Connector pin is contacted to battery voltage or has no contact	OP mode : Substitute clutch control	Check the cable from TCU to the sensor Check the connectors Check the speed sensor	
32	34	<b>S.C. to ground at engine speed input</b> TCU measures a voltage less than 0.45V at speed input pin Cable/connector is defective and is contacted to vehicle ground Speed sensor has an internal defect	OP mode : Substitute clutch control	Check the cable from TCU to the sensor Check the connectors Check the speed sensor	

Fault code (Hex)	Int. code (Dec)	Meaning of the fault code possible reason for fault detection	Reaction of the TCU	Possible steps to repair	Remarks
33	42	<b>Logical error at engine speed input</b> TCU measures a engine speed over a threshold and the next moment the measured speed is zero Cable/connector is defective and has bad contact Speed sensor has an internal defect Sensor gap has the wrong size	OP mode : Substitute clutch control	Check the cable from TCU to the sensor Check the connectors Check the speed sensor Check the sensor gap	This fault is reset after power up of TCU
34	39	<b>S.C. to battery voltage or O.C. at turbine speed input</b> TCU measures a voltage higher than 7.00V at speed input pin Cable is defective and is contacted to vehicle battery voltage Cable has no connection to TCU Speed sensor has an internal defect Connector pin is contacted to battery voltage or has no contact	OP mode : Substitute clutch control If a failure is existing at output speed, TCU shifts to neutral OP mode : Limp home	Check the cable from TCU to the sensor Check the connectors Check the speed sensor	
35	35	<b>S.C. to ground at turbine speed input</b> TCU measures a voltage less than 0.45V at speed input pin Cable/connector is defective and is contacted to vehicle ground Speed sensor has an internal defect	OP mode : Substitute clutch control If a failure is existing at output speed, TCU shifts to neutral OP mode : Limp home	Check the cable from TCU to the sensor Check the connectors Check the speed sensor	This fault is reset after power up of TCU
36	43	<b>Logical error at turbine speed input</b> TCU measures a turbine speed over a threshold and at the next moment the measured speed is zero Cable/connector is defective and has bad contact Speed sensor has an internal defect Sensor gap has the wrong size	OP mode : Substitute clutch control If a failure is existing at output speed, TCU shifts to neutral OP mode : Limp home	Check the cable from TCU to the sensor Check the connectors Check the speed sensor Check the sensor gap	

Fault code (Hex)	Int. code (Dec)	Meaning of the fault code possible reason for fault detection	Reaction of the TCU	Possible steps to repair	Remarks
37	40	<b>S.C. to battery voltage or O.C. at internal speed input</b> TCU measures a voltage higher than 7.00V at speed input pin Cable is defective and is contacted to vehicle battery voltage Cable has no connection to TCU Speed sensor has an internal defect Connector pin is contacted to battery voltage or has no contact	OP mode : Substitute clutch control	Check the cable from TCU to the sensor Check the connectors Check the speed sensor	
38	36	<b>S.C. to ground at turbine speed input</b> TCU measures a voltage less than 0.45V at speed input pin Cable/connector is defective and is contacted to vehicle ground Speed sensor has an internal defect	OP mode : Substitute clutch control	Check the cable from TCU to the sensor Check the connectors Check the speed sensor	
39	44	<b>Logical error at internal speed input</b> TCU measures a internal speed over a threshold and at the next moment the measured speed is zero Cable/connector is defective and has bad contact Speed sensor has an internal defect Sensor gap has the wrong size	OP mode : Substitute clutch control	Check the cable from TCU to the sensor Check the connectors Check the speed sensor Check the sensor gap	This fault is reset after power up of TCU
3A	41	<b>S.C. to battery voltage or O.C. at output speed input</b> TCU measures a voltage higher than 12.5V at speed input pin Cable is defective and is contacted to battery voltage Cable has no connection to TCU Speed sensor has an internal defect Connector pin is contacted to battery voltage or has no contact	Special mode for gear selection OP mode : Substitute clutch control If a failure is existing at turbine speed, TCU shifts to neutral OP mode : lamp home	Check the cable from TCU to the sensor Check the connectors Check the speed sensor	

Fault code (Hex)	Int. code (Dec)	Meaning of the fault code possible reason for fault detection	Reaction of the TCU	Possible steps to repair	Remarks
3B	37	<b>S.C. to ground at output speed input</b> TCU measures a voltage less than 1.00V at speed input pin Cable/connector is defective and is contacted to vehicle ground Speed sensor has an internal defect	Special mode for gear selection OP mode : Substitute clutch control If a failure is existing at turbine speed, TCU shifts to neutral OP mode : lamp home	Check the cable from TCU to the sensor Check the connectors Check the speed sensor	
3C	45	<b>Logical error at output speed input</b> TCU measures a turbine speed over a threshold and at the next moment the measured speed is zero Cable/connector is defective and has bad contact Speed sensor has an internal defect Sensor gap has the wrong size	Special mode for gear selection OP mode : Substitute clutch control If a failure is existing at turbine speed, TCU shifts to neutral OP mode : lamp home	Check the cable from TCU to the sensor Check the connectors Check the speed sensor Check the sensor gap	This fault is reset after power up of TCU
3D	71	<b>Turbine speed zero doesn't fit to other speed signals</b>	-	-	Not used
3E	72	<b>Output speed zero doesn't fit to other speed signals</b> If transmission is not neutral and the shifting has finished, TCU measures output speed zero and turbine speed or internal speed not equal to zero. Speed sensor has an internal defect Sensor gap has the wrong size	Special mode for gear selection OP mode : Substitute clutch control If a failure is existing at turbine speed, TCU shifts to neutral OP mode : lamp home	Check the sensor signal of output speed sensor Check the sensor gap of output speed sensor Check the cable from TCU to the sensor	This fault is reset after power up of TCU



Fault code (Hex)	Int. code (Dec)	Meaning of the fault code possible reason for fault detection	Reaction of the TCU	Possible steps to repair	Remarks
71	22	<b>S.C. to battery voltage at clutch K1</b> The measured resistance value of the valve is out of limit, the voltage at K1 valve is too high Cable/connector is defective and has contact to battery voltage Cable/connector is defective and has contact to another regulator output of the TCU Regulator has an internal defect	TCU shifts to neutral OP mode : Limp home If failure at another clutch is pending TCU shifts to neutral OP mode : TCU shutdown	Check the cable from TCU to the gearbox Check the connectors from TCU to the gearbox Check the regulator resistance* Check internal wire harness of the gearbox	* See Chapter (7)
72	10	<b>S.C. to ground at clutch K1</b> The measured resistance value of the valve is out of limit, the voltage at K1 valve is too low Cable/connector is defective and has contact to vehicle ground Regulator has an internal defect	TCU shifts to neutral OP mode : Limp home If failure at another clutch is pending TCU shifts to neutral OP mode : TCU shutdown	Check the cable from TCU to the gearbox Check the connectors from gearbox to TCU Check the regulator resistance* Check internal wire harness of the gearbox	* See Chapter (7)
73	16	<b>O.C. at clutch K1</b> The measured resistance value of the valve is out of limit Cable/connector is defective and has no contact to TCU Regulator has an internal defect	TCU shifts to neutral OP mode : Limp home If failure at another clutch is pending TCU shifts to neutral OP mode : TCU shutdown	Check the cable from TCU to the gearbox Check the connectors from gearbox to TCU Check the regulator resistance* Check internal wire harness of the gearbox	* See Chapter (7)
74	23	<b>S.C. to battery voltage at clutch K2</b> The measured resistance value of the valve is out of limit, the voltage at K2 valve is too high Cable/connector is defective and has contact to battery voltage Cable/connector is defective and has contact to another regulator output of the TCU Regulator has an internal defect	TCU shifts to neutral OP mode : Limp home If failure at another clutch is pending TCU shifts to neutral OP mode : TCU shutdown	Check the cable from TCU to the gearbox Check the connectors from gearbox to TCU Check the regulator resistance* Check internal wire harness of the gearbox	* See Chapter (7)

Fault code (Hex)	Int. code (Dec)	Meaning of the fault code possible reason for fault detection	Reaction of the TCU	Possible steps to repair	Remarks
75	11	<b>S.C. to ground at clutch K2</b> The measured resistance value of the valve is out of limit, the voltage at K2 valve is too low Cable/connector is defective and has contact to vehicle ground Regulator has an internal defect	TCU shifts to neutral OP mode : Limp home If failure at another clutch is pending TCU shifts to neutral OP mode : TCU shutdown	Check the cable from TCU to the gearbox Check the connectors from gearbox to TCU Check the regulator resistance* Check internal wire harness of the gearbox	* See Chapter (7)
76	17	<b>O.C. at clutch K2</b> The measured resistance value of the valve is out of limit Cable/connector is defective and has no contact to TCU Regulator has an internal defect	TCU shifts to neutral OP mode : Limp home If failure at another clutch is pending TCU shifts to neutral OP mode : TCU shutdown	Check the cable from TCU to the gearbox Check the connectors from gearbox to TCU Check the regulator resistance* Check internal wire harness of the gearbox	* See Chapter (7)
77	24	<b>S.C. to battery voltage at clutch K3</b> The measured resistance value of the valve is out of limit, the voltage at K3 valve is too high Cable/connector is defective and has contact to battery voltage Cable/connector is defective and has contact to another regulator output of the TCU Regulator has an internal defect	TCU shifts to neutral OP mode : Limp home If failure at another clutch is pending TCU shifts to neutral OP mode : TCU shutdown	Check the cable from TCU to the gearbox Check the connectors from gearbox to TCU Check the regulator resistance* Check internal wire harness of the gearbox	* See Chapter (7)
78	12	<b>S.C. to ground at clutch K3</b> The measured resistance value of the valve is out of limit, the voltage at K3 valve is too low Cable/connector is defective and has contact to vehicle ground Regulator has an internal defect	TCU shifts to neutral OP mode : Limp home If failure at another clutch is pending TCU shifts to neutral OP mode : TCU shutdown	Check the cable from TCU to the gearbox Check the connectors from gearbox to TCU Check the regulator resistance* Check internal wire harness of the gearbox	* See Chapter (7)

Fault code (Hex)	Int. code (Dec)	Meaning of the fault code possible reason for fault detection	Reaction of the TCU	Possible steps to repair	Remarks
79	18	<b>O.C. at clutch K2</b> The measured resistance value of the valve is out of limit Cable/connector is defective and has no contact to TCU Regulator has an internal defect	TCU shifts to neutral OP mode : Limp home If failure at another clutch is pending TCU shifts to neutral OP mode : TCU shutdown	Check the cable from TCU to the gearbox Check the connectors from gearbox to TCU Check the regulator resistance* Check internal wire harness of the gearbox	* See Chapter (7)
7A	78	<b>S.C. to battery voltage at converter clutch</b>	-	-	
7B	79	<b>S.C. to ground at converter clutch</b>	-	-	
7C	80	<b>O.C. at converter clutch</b>	-	-	Not used
7D	166	<b>S.C. ground at engine derating device</b> Cable is defective and is contacted to vehicle ground Engine derating device has an internal defect Connector pin is contacted to vehicle ground	Engine derating will be on until TCU power down even if fault vanishes(Loose connection) OP mode : Normal	Check the cable from TCU to the engine derating device Check the connectors from engine derating device to TCU Check the resistance* of engine derating device	Not used Not used * See Chapter (7)
7E	168	<b>S.C. battery voltage at engine derating device</b> Cable/connector is defective and is contacted to battery voltage Engine derating device has an internal defect	No reaction OP mode : Normal	Check the cable from TCU to the engine derating device Check the connectors from backup alarm device to TCU Check the resistance* of backup alarm device	* See Chapter (7)
7F	167	<b>O.C. at engine derating device</b> TCU detected a wrong voltage at the output pin, that looks like a O.C. for this output pin Cable is defective and has no connection to TCU Engine derating device has an internal defect Connector has no connection to TCU	No reaction OP mode : Normal	Check the cable from TCU to the engine derating device Check the connectors from engine derating device to TCU Check the resistance* of engine derating device	* See Chapter (7)

Fault code (Hex)	Int. code (Dec)	Meaning of the fault code possible reason for fault detection	Reaction of the TCU	Possible steps to repair	Remarks
81	25	<b>S.C. to battery voltage at clutch K4</b> The measured resistance value of the valve is out of limit, the voltage at K4 valve is too high Cable/connector is defective and has contact to battery voltage Cable/connector is defective and has contact to another regulator output of the TCU Regulator has an internal defect	TCU shifts to neutral OP mode : Limp home If failure at another clutch is pending TCU shifts to neutral OP mode : TCU shutdown	Check the cable from TCU to the gearbox Check the connectors from gearbox to TCU Check the regulator resistance* Check internal wire harness of the gearbox	* See Chapter (7)
82	13	<b>S.C. to ground at clutch K4</b> The measured resistance value of the valve is out of limit, the voltage at K4 valve is too low Cable/connector is defective and has contact to vehicle ground Regulator has an internal defect	TCU shifts to neutral OP mode : Limp home If failure at another clutch is pending TCU shifts to neutral OP mode : TCU shutdown	Check the cable from TCU to the engine derating device Check the connectors from gearbox to TCU Check the regulator resistance* Check internal wire harness of the gearbox	* See Chapter (7)
83	19	<b>O.C. at clutch K4</b> The measured resistance value of the valve is out of limit Cable/connector is defective and has contact to TCU Regulator has an internal defect	TCU shifts to neutral OP mode : Limp home If failure at another clutch is pending TCU shifts to neutral OP mode : TCU shutdown	Check the cable from TCU to the gearbox Check the connectors from gearbox to TCU Check the regulator resistance* Check internal wire harness of the gearbox	* See Chapter (7)
84	26	<b>S.C. to battery voltage at clutch K4</b> The measured resistance value of the valve is out of limit, the voltage at K4 valve is too high Cable/connector is defective and has contact to battery voltage Cable/connector is defective and has contact to another regulator output of the TCU Regulator has an internal defect	TCU shifts to neutral OP mode : Limp home If failure at another clutch is pending TCU shifts to neutral OP mode : TCU shutdown	Check the cable from TCU to the gearbox Check the connectors from gearbox to TCU Check the regulator resistance* Check internal wire harness of the gearbox	* See Chapter (7)

Fault code (Hex)	Int. code (Dec)	Meaning of the fault code possible reason for fault detection	Reaction of the TCU	Possible steps to repair	Remarks
85	14	<b>S.C. to ground at clutch KV</b> The measured resistance value of the valve is out of limit, the voltage at K4 valve is too low Cable/connector is defective and has contact to vehicle ground Regulator has an internal defect	TCU shifts to neutral OP mode : Limp home If failure at another clutch is pending TCU shifts to neutral OP mode : TCU shutdown	Check the cable from TCU to the gearbox Check the connectors from gearbox to TCU Check the regulator resistance* Check internal wire harness of the gearbox	* See Chapter (7)
86	20	<b>O.C. at clutch KV</b> The measured resistance value of the valve is out of limit Cable/connector is defective and has contact to TCU Regulator has an internal defect	TCU shifts to neutral OP mode : Limp home If failure at another clutch is pending TCU shifts to neutral OP mode : TCU shutdown	Check the cable from TCU to the gearbox Check the connectors from gearbox to TCU Check the regulator resistance* Check internal wire harness of the gearbox	* See Chapter (7)
87	27	<b>S.C. to battery voltage at clutch KR</b> The measured resistance value of the valve is out of limit, the voltage at KR valve is too high Cable/connector is defective and has contact to battery voltage Cable/connector is defective and has contact to another regulator output of the TCU Regulator has an internal defect	TCU shifts to neutral OP mode : Limp home If failure at another clutch is pending TCU shifts to neutral OP mode : TCU shutdown	Check the cable from TCU to the gearbox Check the connectors from gearbox to TCU Check the regulator resistance* Check internal wire harness of the gearbox	* See Chapter (7)
88	15	<b>S.C. to ground at clutch KR</b> The measured resistance value of the valve is out of limit, the voltage at KR valve is too low Cable/connector is defective and has contact to vehicle ground Regulator has an internal defect	TCU shifts to neutral OP mode : Limp home If failure at another clutch is pending TCU shifts to neutral OP mode : TCU shutdown	Check the cable from TCU to the gearbox Check the connectors from gearbox to TCU Check the regulator resistance* Check internal wire harness of the gearbox	* See Chapter (7)
89	21	<b>O.C. at clutch KR</b> The measured resistance value of the valve is out of limit Cable/connector is defective and has no contact to TCU Regulator has an internal defect	TCU shifts to neutral OP mode : Limp home If failure at another clutch is pending TCU shifts to neutral OP mode : TCU shutdown	Check the cable from TCU to the gearbox Check the connectors from gearbox to TCU Check the regulator resistance* Check internal wire harness of the gearbox	* See Chapter (7)

Fault code (Hex)	Int. code (Dec)	Meaning of the fault code possible reason for fault detection	Reaction of the TCU	Possible steps to repair	Remarks
91	1	<b>S.C. to ground at relay reverse warning alarm</b> TCU detected a wrong voltage at the output pin, that looks like a S.C. to vehicle ground Cable is defective and is contact to vehicle ground Backup alarm device has an internal defect Connector pin is contacted to vehicle ground	Backup alarm will be on until TCU power down even if fault vanishes(Loose connection) OP mode : Normal	Check the cable from TCU to the backup alarm device Check the connectors from backup alarm device to TCU Check the resistance* of backup alarm device	* See Chapter (7)
92	3	<b>S.C. to battery voltage at relay reverse warning alarm</b> TCU detected a wrong voltage at the output pin, that looks like a S.C. to battery voltage Cable is defective and is contacted to battery voltage Backup alarm device has an internal defect Connector pin is contacted to battery voltage	No reaction OP mode : Normal	Check the cable from TCU to the backup alarm device Check the connectors from backup alarm device to TCU Check the resistance* of backup alarm device	* See Chapter (7)
93	2	<b>O.C. at relay reverse warning alarm</b> TCU detected a wrong voltage at the output pin, that looks like a O.C. for this output pin Cable is defective and has no connection to TCU Backup alarm device has an internal defect Connector has no connection to TCU	No reaction OP mode : Normal	Check the cable from TCU to the backup alarm device Check the connectors from backup alarm device to TCU Check the resistance* of backup alarm device	* See Chapter (7)
94	4	<b>S.C. to ground at relay starter interlock</b> TCU detected a wrong voltage at the output pin, that looks like a S.C. to vehicle ground Cable is defective and is connection to vehicle ground Starter interlock relay has an internal defect Connector pin is contacted to vehicle ground	No reaction OP mode : Normal	Check the cable from TCU to the starter interlock relay Check the connectors from starter interlock relay to TCU Check the resistance* of starter interlock relay	* See Chapter (7)

Fault code (Hex)	Int. code (Dec)	Meaning of the fault code possible reason for fault detection	Reaction of the TCU	Possible steps to repair	Remarks
95	6	<b>S.C. to battery voltage at relay starter interlock</b> TCU detected a wrong voltage at the output pin, that looks like a S.C. to battery voltage Cable is defective and has no connection to battery voltage Starter interlock relay has an internal defect Connector pin is contacted to battery voltage	No reaction OP mode : Normal	Check the cable from TCU to the starter interlock relay Check the connectors from starter interlock relay to TCU Check the resistance* of starter interlock relay	* See Chapter (7)
96	5	<b>O.C. at relay starter interlock</b> TCU detected a wrong voltage at the output pin, that looks like a O.C. for this output pin Cable is defective and has no connection to TCU Starter interlock relay has an internal defect Connector has no connection to TCU	No reaction OP mode : Normal	Check the cable from TCU to the starter interlock relay Check the connectors from starter interlock relay to TCU Check the resistance* of starter interlock relay	* See Chapter (7)
97	7	<b>S.C. to ground at park brake solenoid</b> TCU detected a wrong voltage at the output pin, that looks like a S.C. to vehicle ground Cable is defective and is connection to vehicle ground Park brake solenoid has an internal defect Connector pin is contacted to vehicle ground	No reaction OP mode : Normal	Check the cable from TCU to the park brake solenoid Check the connectors from park brake solenoid to TCU Check the resistance* of park brake solenoid	* See Chapter (7)
98	9	<b>S.C. to battery voltage at park brake solenoid</b> TCU detected a wrong voltage at the output pin, that looks like a S.C. to battery voltage Cable is defective and is connection to battery voltage Park brake solenoid has an internal defect Connector pin is contacted to battery voltage	No reaction Optional : (Some customers) TCU shifts to neutral caused by park brake feed back OP mode : Normal	Check the cable from TCU to the park brake solenoid Check the connectors from park brake solenoid to TCU Check the resistance* of park brake solenoid	* See Chapter (7)

Fault code (Hex)	Int. code (Dec)	Meaning of the fault code possible reason for fault detection	Reaction of the TCU	Possible steps to repair	Remarks
99	8	<b>O.C. at park brake solenoid</b> TCU detected a wrong voltage at the output pin, that looks like a O.C. for this output pin Cable is defective and has no connection to TCU Park brake solenoid has an internal defect Connector has no connection to TCU	No reaction Optional : Some customers TCU shifts to neutral caused by park brake feed back OP mode : Normal	Check the cable from TCU to the park brake solenoid Check the connectors from park brake solenoid to TCU Check the resistance* of park brake solenoid	* See Chapter (7)
9A	66	<b>S.C. to ground at converter lock up clutch solenoid</b> TCU detected a wrong voltage at the output pin, that looks like a S.C. to vehicle ground Cable is defective and is contacted to vehicle ground Converter clutch solenoid has an internal defect Connector pin is contacted to vehicle ground	No reaction OP mode : Normal	Check the cable from TCU to the converter clutch solenoid Check the connectors from converter clutch solenoid to TCU Check the resistance* of park brake solenoid	* See Chapter (7)
9B	67	<b>O.C. at converter lock up clutch solenoid</b> TCU detected a wrong voltage at the output pin, that looks like a O.C. for this output pin Cable is defective and has no connection to TCU Converter clutch solenoid has an internal defect Connector has no connection to TCU	Converter clutch always open, retarder not available OP mode : Normal	Check the cable from TCU to the converter clutch solenoid Check the connectors from converter clutch solenoid to TCU Check the resistance* of park brake solenoid	* See Chapter (7)
9C	68	<b>S.C. to battery voltage at converter lock up clutch solenoid</b> TCU detected a wrong voltage at the output pin, that looks like a S.C. to battery voltage Cable is defective and has no contacted to battery voltage Converter clutch solenoid has an internal defect Connector pin is contacted to battery voltage	No reaction OP mode : Normal	Check the cable from TCU to the converter clutch solenoid Check the connectors from converter clutch solenoid to TCU Check the resistance* of converter clutch solenoid	* See Chapter (7)



Fault code (Hex)	Int. code (Dec)	Meaning of the fault code possible reason for fault detection	Reaction of the TCU	Possible steps to repair	Remarks
9D	81	<b>S.C. to ground at retarder solenoid</b> TCU detected a wrong voltage at the output pin, that looks like a S.C. to vehicle ground Cable is defective and is contacted to vehicle ground Retarder solenoid has an internal defect Connector pin is contacted to vehicle ground	No reaction OP mode : Normal	Check the cable from TCU to the retarder solenoid Check the connectors from retarder solenoid to TCU Check the resistance* of retarder solenoid	* See Chapter (7)
9E	82	<b>O.C. at retarder solenoid</b> TCU detected a wrong voltage at the output pin, that looks like a O.C. for this output pin Cable is defective and has no connection to TCU Retarder solenoid has an internal defect Connector has no connection to TCU	No reaction OP mode : Normal	Check the cable from TCU to the retarder solenoid Check the connectors from retarder solenoid to TCU Check the resistance* of retarder solenoid	* See Chapter (7)
9F	83	<b>S.C. to battery voltage at retarder solenoid</b> TCU detected a wrong voltage at the output pin, that looks like a S.C. to battery voltage Cable is defective and has no connection to battery voltage Retarder solenoid has an internal defect Connector pin is contacted to battery voltage	No reaction OP mode : Normal	Check the cable from TCU to the retarder solenoid Check the connectors from retarder solenoid to TCU Check the resistance* of retarder solenoid	* See Chapter (7)

Fault code (Hex)	Int. code (Dec)	Meaning of the fault code possible reason for fault detection	Reaction of the TCU	Possible steps to repair	Remarks
A1	84	<b>S.C. to ground at difflock or axle connection solenoid</b> TCU detected a wrong voltage at the output pin, that looks like a S.C. to vehicle ground Cable is defective and is contacted to vehicle ground Difflock solenoid has an internal defect Connector pin is contacted to vehicle ground	No reaction OP mode : Normal	Check the cable from TCU to the difflock solenoid Check the connectors from difflock solenoid to TCU Check the resistance* of difflock solenoid	* See Chapter (7)
A2	85	<b>S.C. to battery voltage at difflock or axle connection solenoid</b> TCU detected a wrong voltage at the output pin, that looks like a S.C. to battery voltage Cable is defective and has no connection to battery voltage Difflock solenoid has an internal defect Connector pin is contacted to battery voltage	No reaction OP mode : Normal	Check the cable from TCU to the difflock solenoid Check the connectors from difflock solenoid to TCU Check the resistance* of difflock solenoid	* See Chapter (7)
A3	86	<b>O.C. at difflock or axle connection solenoid</b> TCU detected a wrong voltage at the output pin, that looks like a O.C. for this output pin Cable is defective and has no connection to TCU Difflock solenoid has an internal defect Connector has no connection to TCU	No reaction OP mode : Normal	Check the cable from TCU to the difflock solenoid Check the connectors from difflock solenoid to TCU Check the resistance* of difflock solenoid	* See Chapter (7)
A4	96	<b>S.C. to ground at warning signal output</b> TCU detected a wrong voltage at the output pin, that looks like a S.C. to vehicle ground Cable is defective and is contacted to vehicle ground Warning device has an internal defect Connector pin is contacted to vehicle ground	No reaction OP mode : Normal	Check the cable from TCU to the warning device Check the connectors from warning device to TCU Check the resistance* of warning device	* See Chapter (7)

Fault code (Hex)	Int. code (Dec)	Meaning of the fault code possible reason for fault detection	Reaction of the TCU	Possible steps to repair	Remarks
A5	97	<b>O.C. voltage at warning signal output</b> TCU detected a wrong voltage at the output pin, that looks like a O.C. for this output pin Cable is defective and has no connection to TCU Warning device has an internal defect Connector has no connection to TCU	No reaction OP mode : Normal	Check the cable from TCU to the warning device Check the connectors from warning device to TCU Check the resistance* of warning device	* See Chapter (7)
A6	98	<b>S.C. to battery voltage at warning signal output</b> TCU detected a wrong voltage at the output pin, that looks like a S.C. to battery voltage Cable is defective and has is contacted to battery voltage Warning device has an internal defect Connector pin is contacted to battery voltage	No reaction OP mode : Normal	Check the cable from TCU to the warning device Check the connectors from warning device to TCU Check the resistance* of warning device	* See Chapter (7)

Fault code (Hex)	Int. code (Dec)	Meaning of the fault code possible reason for fault detection	Reaction of the TCU	Possible steps to repair	Remarks
B1	60	<b>Slippage at clutch K1</b> TCU calculates a differential speed at closed clutch K1. If this calculated value is out of range, TCU interprets this as slipping clutch Low pressure at clutch K1 Low main pressure Wrong signal at internal speed sensor Wrong signal at output speed sensor Wrong size of the sensor gap Clutch is defective	TCU shifts to neutral OP mode : Limp home If failure at another clutch is pending TCU shifts to neutral OP mode : TCU shutdown	Check pressure at clutch K1 Check main pressure in the system Check sensor gap at internal speed sensor Check sensor gap at output speed sensor Check signal at internal speed sensor Check signal at output speed sensor Replace clutch	
B2	61	<b>Slippage at clutch K2</b> TCU calculates a differential speed at closed clutch K2. If this calculated value is out of range, TCU interprets this as slipping clutch Low pressure at clutch K2 Low main pressure Wrong signal at internal speed sensor Wrong signal at output speed sensor Wrong size of the sensor gap Clutch is defective	TCU shifts to neutral OP mode : Limp home If failure at another clutch is pending TCU shifts to neutral OP mode : TCU shutdown	Check pressure at clutch K2 Check main pressure in the system Check sensor gap at internal speed sensor Check sensor gap at output speed sensor Check signal at internal speed sensor Check signal at output speed sensor Replace clutch	
B3	62	<b>Slippage at clutch K3</b> TCU calculates a differential speed at closed clutch K3. If this calculated value is out of range, TCU interprets this as slipping clutch Low pressure at clutch K3 Low main pressure Wrong signal at internal speed sensor Wrong signal at output speed sensor Wrong size of the sensor gap Clutch is defective	TCU shifts to neutral OP mode : Limp home If failure at another clutch is pending TCU shifts to neutral OP mode : TCU shutdown	Check pressure at clutch K3 Check main pressure in the system Check sensor gap at internal speed sensor Check sensor gap at output speed sensor Check signal at internal speed sensor Check signal at output speed sensor Replace clutch	

Fault code (Hex)	Int. code (Dec)	Meaning of the fault code possible reason for fault detection	Reaction of the TCU	Possible steps to repair	Remarks
B4	63	<p><b>Slippage at clutch K4</b>  TCU calculates a differential speed at closed clutch K4. If this calculated value is out of range, TCU interprets this as slipping clutch</p> <ul style="list-style-type: none"> <li>Low pressure at clutch K4</li> <li>Low main pressure</li> <li>Wrong signal at internal speed sensor</li> <li>Wrong signal at turbine speed sensor</li> <li>Wrong size of the sensor gap</li> <li>Clutch is defective</li> </ul>	<p>TCU shifts to neutral  OP mode : Limp home  If failure at another clutch is pending  TCU shifts to neutral  OP mode : TCU shutdown</p>	<ul style="list-style-type: none"> <li>Check pressure at clutch K4</li> <li>Check main pressure in the system</li> <li>Check sensor gap at internal speed sensor</li> <li>Check sensor gap at turbine speed sensor</li> <li>Check signal at internal speed sensor</li> <li>Check signal at turbine speed sensor</li> <li>Replace clutch</li> </ul>	
B5	64	<p><b>Slippage at clutch KV</b>  TCU calculates a differential speed at closed clutch KV. If this calculated value is out of range, TCU interprets this as slipping clutch</p> <ul style="list-style-type: none"> <li>Low pressure at clutch KV</li> <li>Low main pressure</li> <li>Wrong signal at internal speed sensor</li> <li>Wrong signal at turbine speed sensor</li> <li>Wrong size of the sensor gap</li> <li>Clutch is defective</li> </ul>	<p>TCU shifts to neutral  OP mode : Limp home  If failure at another clutch is pending  TCU shifts to neutral  OP mode : TCU shutdown</p>	<ul style="list-style-type: none"> <li>Check pressure at clutch KV</li> <li>Check main pressure in the system</li> <li>Check sensor gap at internal speed sensor</li> <li>Check sensor gap at turbine speed sensor</li> <li>Check signal at internal speed sensor</li> <li>Check signal at turbine speed sensor</li> <li>Replace clutch</li> </ul>	
B6	65	<p><b>Slippage at clutch KR</b>  TCU calculates a differential speed at closed clutch KR. If this calculated value is out of range, TCU interprets this as slipping clutch</p> <ul style="list-style-type: none"> <li>Low pressure at clutch KR</li> <li>Low main pressure</li> <li>Wrong signal at internal speed sensor</li> <li>Wrong signal at turbine speed sensor</li> <li>Wrong size of the sensor gap</li> <li>Clutch is defective</li> </ul>	<p>TCU shifts to neutral  OP mode : Limp home  If failure at another clutch is pending  TCU shifts to neutral  OP mode : TCU shutdown</p>	<ul style="list-style-type: none"> <li>Check pressure at clutch KR</li> <li>Check main pressure in the system</li> <li>Check sensor gap at internal speed sensor</li> <li>Check sensor gap at turbine speed sensor</li> <li>Check signal at internal speed sensor</li> <li>Check signal at turbine speed sensor</li> <li>Replace clutch</li> </ul>	

Fault code (Hex)	Int. code (Dec)	Meaning of the fault code possible reason for fault detection	Reaction of the TCU	Possible steps to repair	Remarks
B7	87	<b>Overtemp sump</b> TCU measured a temperature in the oil sump that is over the allowed threshold.	No reaction OP mode : Normal	Cool down machine Check oil level Check temperature sensor	
B8	88	<b>Overtemp retarder</b> TCU measured a temperature in the retarder oil that is over the allowed threshold	TCU disables retarder OP mode : Normal	Cool down machine Check oil level Check temperature sensor	
B9	89	<b>Overspend engine</b>	Retarder applies OP mode : Normal	-	
BA	90	<b>Differential pressure oil filter</b> TCU measured a voltage at differential pressure switch out of the allowed range Oil filter is polluted Cable/connector is broken or cable/connector is contacted to battery voltage or vehicle ground Differential pressure switch is defective	No reaction OP mode : Normal	Check oil filter Check wiring from TCU to differential pressure switch Check differential pressure switch(Measure resistance)	
BB	172	<b>Slippage at converter lockup clutch</b> TCU calculates a differential speed at closed converter lockup clutch. If this calculated value is out of range, TCU interprets this as slipping clutch Low pressure at converter lockup clutch Low main pressure Wrong signal at engine speed sensor Wrong signal at turbine speed sensor Wrong size of the sensor gap Clutch is defective		Check pressure at converter lockup clutch Check main pressure in the system Check sensor gap at engine speed sensor Check sensor gap at turbine speed sensor Check signal at engine speed sensor Check signal at turbine speed sensor Replace clutch	

Fault code (Hex)	Int. code (Dec)	Meaning of the fault code possible reason for fault detection	Reaction of the TCU	Possible steps to repair	Remarks
BD	169	<b>S.C. to ground at engine brake solenoid</b> TCU detected a wrong voltage at the output pin, that looks like a S.C. to vehicle ground Cable is defective and is contacted to vehicle ground Engine brake solenoid has an internal defect Connector pin is contacted to vehicle ground	No reaction OP mode : Normal	Check the cable from TCU to engine brake solenoid Check the connectors from engine brake solenoid to TCU Check the resistance* of engine brake solenoid	* See Chapter (7)
BE	171	<b>S.C. to battery voltage at engine brake</b> TCU detected a wrong voltage at the output pin, that looks like a S.C. to battery voltage Cable is defective and is contacted to battery voltage Engine brake solenoid has an internal defect Connector pin is contacted to battery voltage	No reaction OP mode : Normal	Check the cable from TCU to the engine brake solenoid Check the connectors from engine brake solenoid to TCU Check the resistance* of engine brake solenoid	* See Chapter (7)
BF	170	<b>O.C. at engine brake</b> TCU detected a wrong voltage at the output pin, that looks like a O.C. for this output pin Cable is defective and has no connection to TCU Engine brake solenoid has an internal defect Connector has no connection to TCU	No reaction OP mode : Normal	Check the cable from TCU to the engine brake solenoid Check the connectors from engine brake solenoid to TCU Check the resistance* of engine brake solenoid	* See Chapter (7)

Fault code (Hex)	Int. code (Dec)	Meaning of the fault code possible reason for fault detection	Reaction of the TCU	Possible steps to repair	Remarks
C3	91	<b>Overtemp converter output</b> TCU measured a oil temperature at the converter output that is the allowed threshold	No reaction OP mode : Normal	Cool down machine Check oil level Check temperature sensor	
C4	129	<b>S.C. to ground at joystick status indicator</b> TCU detected a wrong voltage at the output pin, that looks like a S.C. to vehicle ground Cable is defective and is contacted to vehicle ground Joystick status indicator has an internal defect Connector pin is contacted to vehicle ground	No reaction OP mode : Normal	Check the cable from TCU to joystick status indicator Check the connectors from joystick status indicator to TCU Check the resistance* of joystick status indicator	*See chapter (7)
C5	131	<b>S.C. to battery voltage at joystick status indicator</b> TCU detected a wrong voltage at the output pin, that looks like a S.C. to battery voltage Cable is defective and is contacted to battery voltage Joystick status indicator has an internal defect Connector pin is contacted to battery voltage	No reaction OP mode : Normal	Check the cable from TCU to joystick status indicator Check the connectors from joystick status indicator to TCU Check the resistance* of joystick status indicator	*See chapter (7)
C6	130	<b>O.C. at joystick status indicator</b> TCU detected a wrong voltage at the output pin, that looks like a O.C. for this output pin Cable is defective and has no connection to TCU Joystick status indicator has an internal defect Connector pin has no connection to TCU	No reaction OP mode : Normal	Check the cable from TCU to joystick status indicator Check the connectors from joystick status indicator to TCU Check the resistance* of joystick status indicator	*See chapter (7)



Fault code (Hex)	Int. code (Dec)	Meaning of the fault code possible reason for fault detection	Reaction of the TCU	Possible steps to repair	Remarks
D1	54	<b>S.C. to battery voltage at power supply for sensors</b> TCU measures more than 6V at the pin AU1 (5V sensor supply)	See fault codes No.21 to 2C	Check cables and connectors to sensors, which are supplied from AU1 Check the power supply at the pin AU1(Should be appx. 5V)	Fault codes No.21 to No.2C may be reaction of this fault
D2	55	<b>S.C. to ground at power supply for sensors</b> TCU measures less than 4V at the pin AU1 (5V sensor supply)	See fault codes No.21 to 2C	Check cables and connectors to sensors, which are supplied from AU1 Check the power supply at the pin AU1(Should be appx. 5V)	Fault codes No.21 to No.2C may be reaction of this fault
D3	53	<b>Low voltage at battery</b> Measured voltage at power supply is lower than 18V(24V device)	Shift to neutral OP mode : TCU shutdown	Check power supply battery Check cables from batteries to TCU Check connectors from batteries to TCU	
D4	52	<b>High voltage at battery</b> Measured voltage at power supply is higher than 32.5V(24V device)	Shift to neutral OP mode : TCU shutdown	Check power supply battery Check cables from batteries to TCU Check connectors from batteries to TCU	
D5	57	<b>Error at valve power supply VPS1</b> TCU switched on VPS1 and measured VPS1 is off or TCU switched off VPS1 and measured VPS1 is still on Cable or connectors are defect and are contacted to battery voltage Cable or connectors are defect and are contacted to vehicle ground Permanent power supply KL30 missing TCU has an internal defect	Shift to neutral OP mode : TCU shutdown	Check fuse Check cables from gearbox to TCU Check connectors from gearbox to TCU Replace TCU	

Fault code (Hex)	Int. code (Dec)	Meaning of the fault code possible reason for fault detection	Reaction of the TCU	Possible steps to repair	Remarks
D6	58	<b>Error at valve power supply VPS2</b> TCU switched on VPS2 and measured VPS2 is off or TCU switched off VPS2 and measured VPS2 is still on Cable or connectors are defect and are contacted to battery voltage Cable or connectors are defect and are contacted to vehicle ground Permanent power supply KL30 missing TCU has an internal defect	Shift to neutral OP mode : TCU shutdown	Check fuse Check cables from gearbox to TCU Check connectors from gearbox to TCU Replace TCU	

Fault code (Hex)	Int. code (Dec)	Meaning of the fault code possible reason for fault detection	Reaction of the TCU	Possible steps to repair	Remarks
E1	91	<b>S.C. battery voltage at speedometer output</b>	-	-	Not used
E2	92	<b>S.C. to ground or O.C at speedometer output</b>	-	-	Not used
E3		<b>S.C. to battery voltage at display output</b> TCU sends data to the display and measures always a high voltage level on the connector Cable or connectors are defective and are contacted to battery voltage Display has an internal defect	No reaction OP mode : Normal	Check the cable from TCU to the display Check the connectors at the display Change display	
E4		<b>S.C. to ground at display output</b> TCU sends data to the display and measures always a high voltage level on the connector Cable or connectors are defective and are contacted to battery voltage Display has an internal defect	No reaction OP mode : Normal	Check the cable from TCU to the display Check the connectors at the display Change display	
E5	93, 104	<b>Communication failure on DeviceNet</b>	Shift to neutral OP mode : TCU shutdown	Check Omron master Check wire of DeviceNet-Bus Check cable to Omron master	
E5	104	<b>DISPID1 timeout</b> Timeout of CAN-message DISPID1 from display controller Interference on CAN-Bus CAN wire/connector is defective Can wire/connector is defective and has contact to vehicle ground or battery voltage	TCU select parameter set with ID0 OP mode : Limp home	Check display controller Check wire of CAN-Bus Check cable display controller	

Fault code (Hex)	Int. code (Dec)	Meaning of the fault code possible reason for fault detection	Reaction of the TCU	Possible steps to repair	Remarks
F1	51	<b>General EEPROM fault</b> TCU can't read non volatile memory TCU is defective	No reaction OP mode : Normal	Replace TCU	Often shown together with fault code F2
F2	56	<b>Configuration lost</b> TCU has lost the correct configuration and can't control the transmission Interference during saving data on non volatile memory TCU is brand new or from another vehicle	Transmission stay neutral OP mode : TCU shutdown	Reprogram the correct configuration for the vehicle (e.g. with cluster controller,...)	
F3	59	<b>Application error</b> Something of this application is wrong	Transmission stay neutral OP mode : TCU shutdown	Replace TCU	This fault occurs only if an test engineer did something wrong in the application of the vehicle
F5	173	<b>Clutch failure</b> AEB was not able to adjust clutch filling parameters One of the AEB-Values is out of limit	Transmission stay neutral OP mode : TCU shutdown	Check clutch	TCU shows also the affected clutch on the display
F6	174	<b>Clutch adjustment data lost</b> TCU was not able to read correct clutch adjustment parameters Interference during saving data on non volatile memory TCU is brand new	No reaction, Default values : 0 for AEB Offsets used OP mode : Normal	Execute AEB	

(7) Measuring of resistance at actuator/sensor and cable

① Actuator

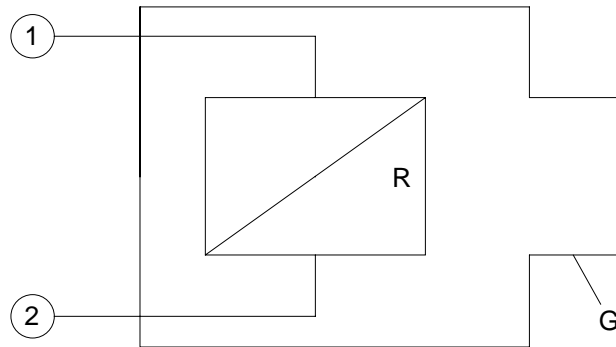

76043PT19

Open circuit	$R_{12} = R_{1G} = R_{2G} = \infty$
Short cut to ground	$R_{12} = R$ ; $R_{1G} = 0, R_{2G} = R$ or $R_{1G} = R, R_{2G} = 0$ (For S.C. to ground, G is connected to vehicle ground)
Short cut to battery	$R_{12} = R$ ; $R_{1G} = 0, R_{2G} = R$ or $R_{1G} = R, R_{2G} = 0$ (For S.C. to battery, G is connected to battery voltage)

② Cable

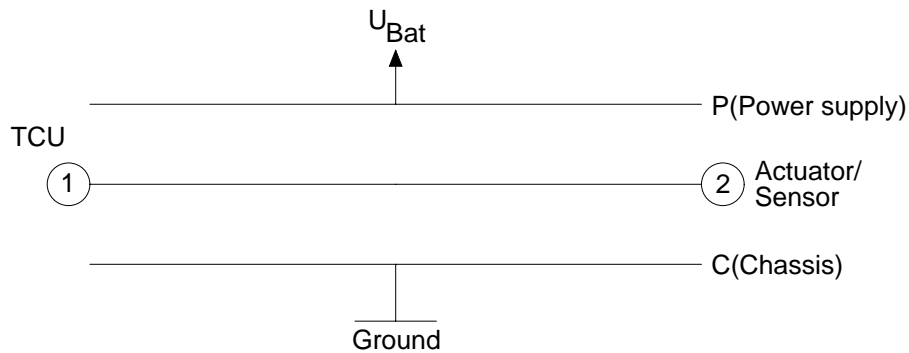

76043PT20

Open circuit	$R_{12} = R_{1P} = R_{1C} = R_{2P} = R_{2C} = \infty$
Short cut to ground	$R_{12} = 0$ ; $R_{1C} = R_{2C} = 0, R_{1P} = R_{2P} = \infty$
Short cut to battery	$R_{12} = 0$ ; $R_{1C} = R_{2C} = 0, R_{1P} = R_{2P} = 0$

## 7) ELECTRIC CONTROL UNIT

### (1) Complete system

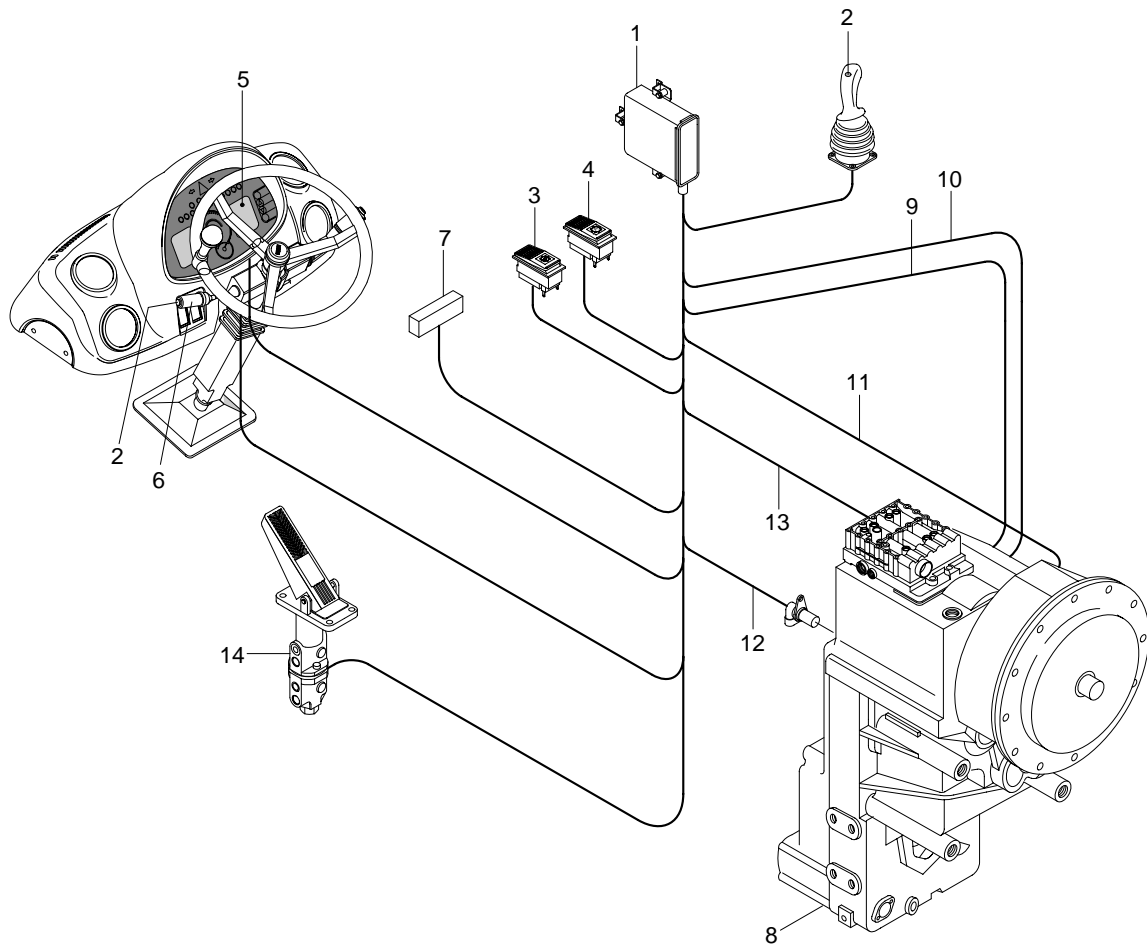

7707PT03

- 1 Control unit(EST-37A)
- 2 Kickdown switch
- 3 Clutch cut off switch
- 4 Full automatic switch
- 5 LCD
- 6 Gear selector(DW-3) with integrated kickdown switch
- 7 Supply-system connection
- 8 Transmission
- 9 Cable to inductive transmitter - speed central gear train
- 10 Cable to inductive transmitter - speed turbine
- 11 Cable to inductive transmitter - speed engine
- 12 Cable to speed sensor output and speedometer
- 13 Cable to plug connection on the electro - hydraulic control unit
- 14 Brake pressure sensor/load sensor

### (2) Description of the basic functions

The powershift-reversing transmissions will be equipped with the electronic transmission control unit(EST-37A), developed for them.

The system is processing the wishes of the driver according to the following criteria.

- Speed definition as a function of gear selector position, driving speed and load level.

- Protection against operating errors, as far as possible and practical.
- Protection against overspeeds(On the basis of engine and turbine speed).
- Reversing-automatic system(Driving speed-dependent).
- Pressure cut off(Disconnecting of the drive train for maximum power on the power take-off).
- Switch for manual or automatic operation.
- Reversing function button, respectively kickdown function.

### (3) Gearshifts

The control unit(EST-37A) shifts the required speeds fully-automatically under consideration of the following criteria.

- Gear selector position
- Driving speed
- Load level

At the same time, the following speeds are picked up by the control unit(EST-37A).

- n Engine
- n Turbine
- n Central gear train
- n Output

#### - Neutral position

Neutral position is selected through the gear selector.

After the ignition is turned on, the electronics remains in the waiting state; By the position **neutral** of the gear selector, respectively by pressing on the key **neutral**, the control unit(EST-37A) becomes ready for operation.

Now, a speed can be engaged.

#### - Speed engagement

In principle, the speed, adapted to the driving speed(At standing, or rolling machine), will be engaged. The engagement is realized in dependence on load and rotational speed.

#### - Upshifting under load

Upshifting under load will be then realized if the machine can still accelerate by it.

#### - Downshifting under load

Downshifting under load will be realized if more traction force is needed.

#### - Upshifting in coasting condition

In the coasting condition, the upshifting will be suppressed if the speed of the machine on a slope shall not be further increased.

#### - Downshifting in coasting condition

Downshiftings in the coasting condition will be realized if the machine shall be retarded.

#### - Reversing

At speeds below the reversing limit, direct reversing can be carried out at any time in the speeds 1F 1R and 2F 2R(As a rule, this is the maximum driving speed of the 2nd speed).

**Reversings in the speeds 3 and 4 are realized dependent on the driving speed.**

- Above the programmed reversing limit, the machine is braked down by downshifts of the electronic control unit(EST-37A) to the permitted driving speed, and only then, the reversing into the correspondingly preselected speed will be carried out.
- Below the permitted driving speed, the reversing is carried out immediately.

**(4) Specific kickdown function**

By means of the kickdown-button, integrated in the gear selector, it is at any time possible to select in the speeds 2F and 2R(i.e. position 2 of the gear selector, at automatic mode also in the 2nd speed of the automatic range) the 1st speed by a short touch. This kickdown state can be cancelled by :

1. Pressing the kickdown-button again
2. Realization of a reversal operation
3. Change of the gear selector position by the following modification  
Gear selector(DW-3) - (Rotation) of the driving position 1...4.

The kickdown function will be always terminated by shifting to neutral.

**(5) Clutch cut off**

Especially at wheel loaders, the clutch cut off can be activated through a switch signal. It is interrupting the power flow in the transmission as long as this signal is active. Besides, this function can be used for the transmission-neutral shifting at applied hand brake or as **emergency-stop**(In this case, a restarting is only possible through the gear selector-neutral position).



**5. AXLE**

**1) OPERATION**

- The power from the engine passes through torque converter, transmission and drive shafts, and is then sent to the front and rear axles.
- Inside the axles, the power passes from the bevel pinion to the bevel gear and is sent at right angles. At the same time, the speed is reduced and passes through the both differentials to the axle shafts. The power of the axle shafts is further reduced by planetary-gear-type final drives and is sent to the wheels.

**(1) Front axle**

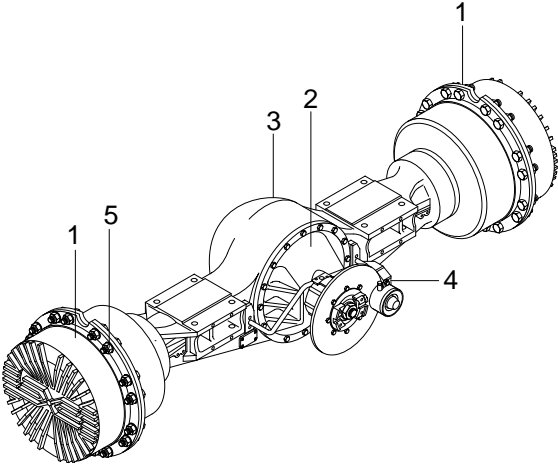

7707PT04

- |                |                 |             |
|----------------|-----------------|-------------|
| 1 Final drive  | 3 Housing       | 5 Wheel nut |
| 2 Differential | 4 Parking brake |             |

**(2) Rear axle**

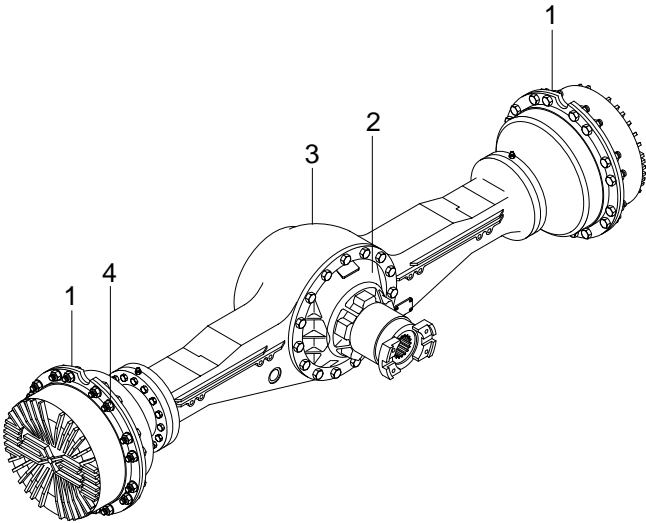

7707PT05

- |               |                |           |             |
|---------------|----------------|-----------|-------------|
| 1 Final drive | 2 Differential | 3 Housing | 4 Wheel nut |
|---------------|----------------|-----------|-------------|

## 2) FRONT AXLE DIFFERENTIAL SECTION

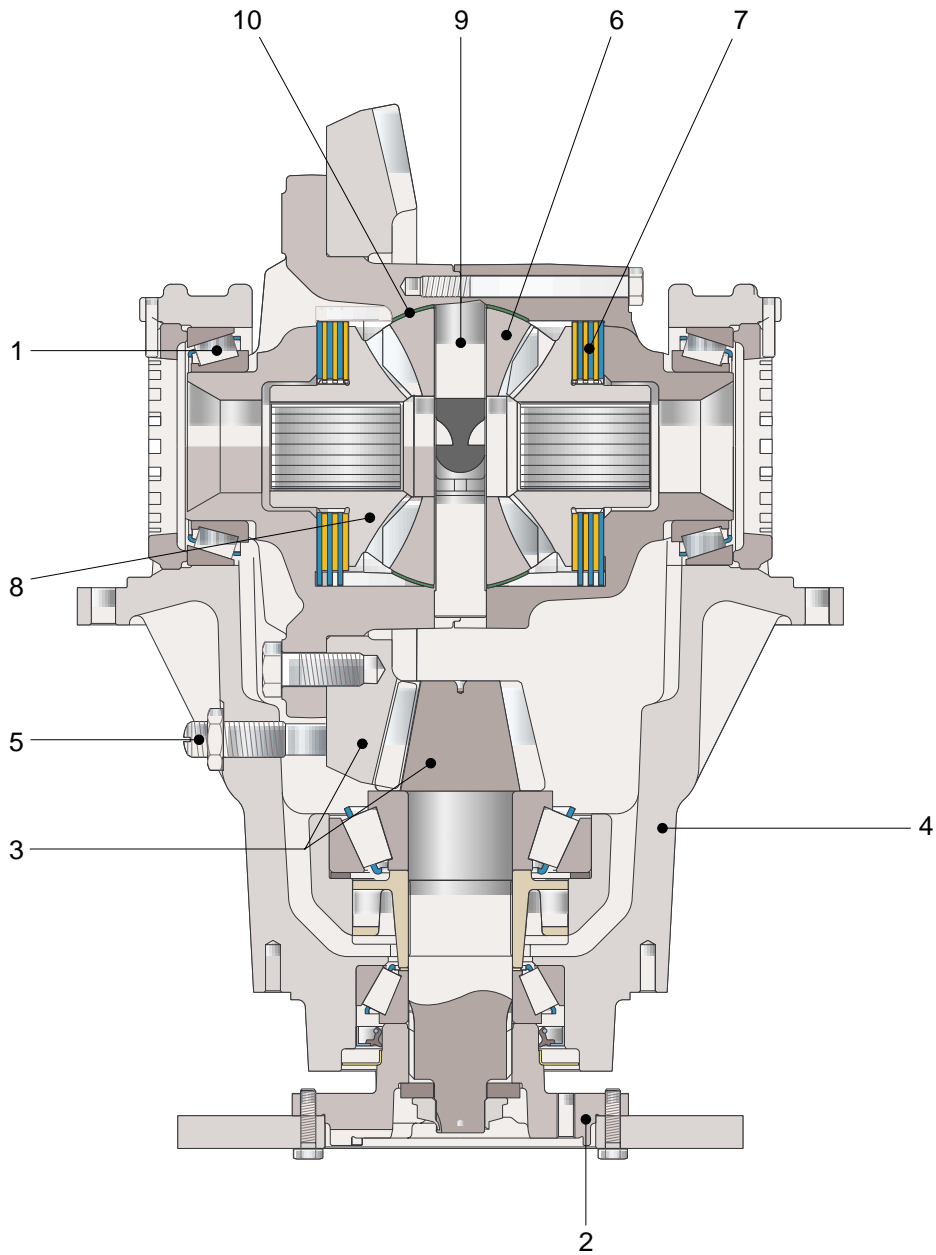

7707PT14

- |   |                      |    |                                  |
|---|----------------------|----|----------------------------------|
| 1 | Roller bearing       | 6  | Side gear                        |
| 2 | Input flange         | 7  | Clutch                           |
| 3 | Bevel gear set       | 8  | Planetary gear                   |
| 4 | Differential housing | 9  | Spider                           |
| 5 | Adjusting screw      | 10 | Bevel thrust washer of side gear |

### 3) REAR AXLE DIFFERENTIAL SECTION

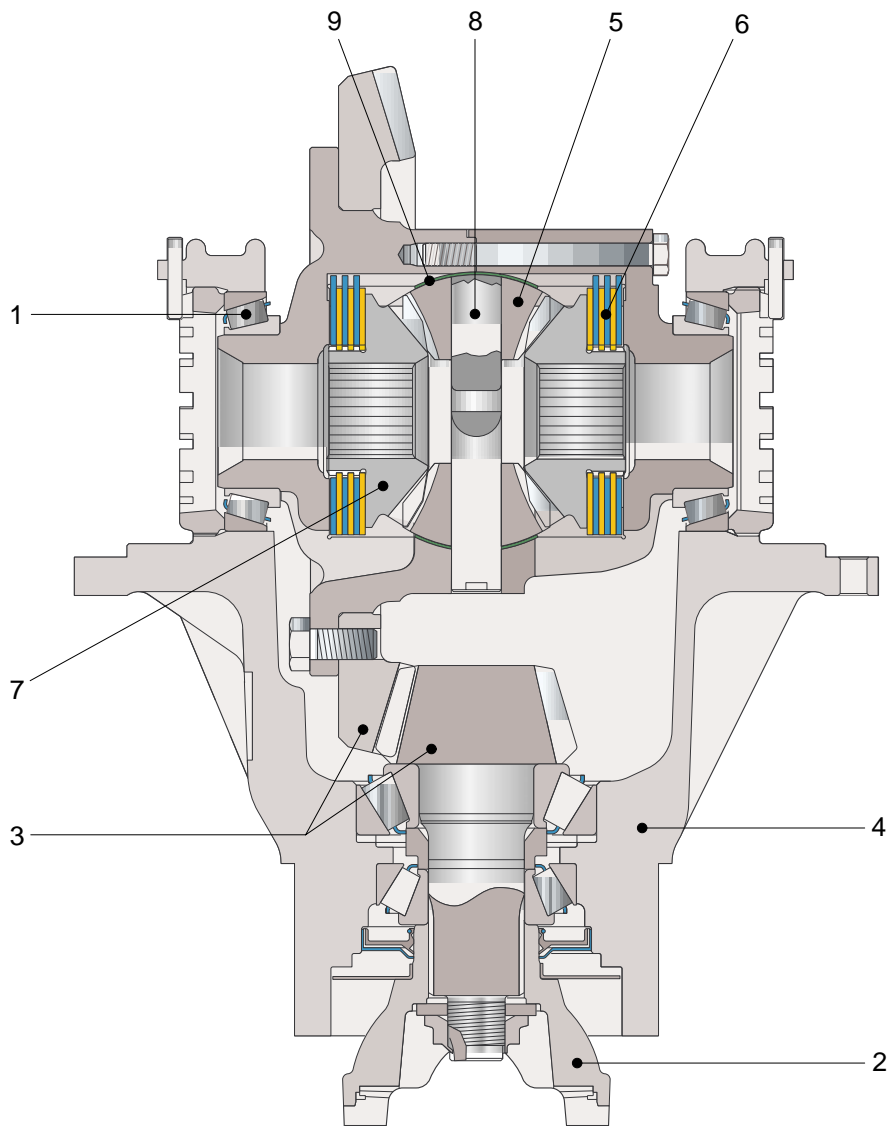

7707PT15

- |   |                      |   |                                  |
|---|----------------------|---|----------------------------------|
| 1 | Roller bearing       | 6 | Clutch                           |
| 2 | Input flange         | 7 | Planetary gear                   |
| 3 | Bevel gear set       | 8 | Spider                           |
| 4 | Differential housing | 9 | Bevel thrust washer of side gear |
| 5 | Side gear            |   |                                  |

#### 4) DIFFERENTIAL

##### (1) Description

When the machine makes a turn, the outside wheel must rotate faster than the inside wheel. A differential is a device which continuously transmits power to the right and left wheels while allowing them to turn at different speeds, during a turn.

The power from the drive shaft passes through bevel pinion(1) and is transmitted to the bevel gear(2). The bevel gear changes the direction of the motive force by 90 degree, and at the same time reduces the speed.

It then transmits the motive force through the differential(3) to the axle gear shaft(4).

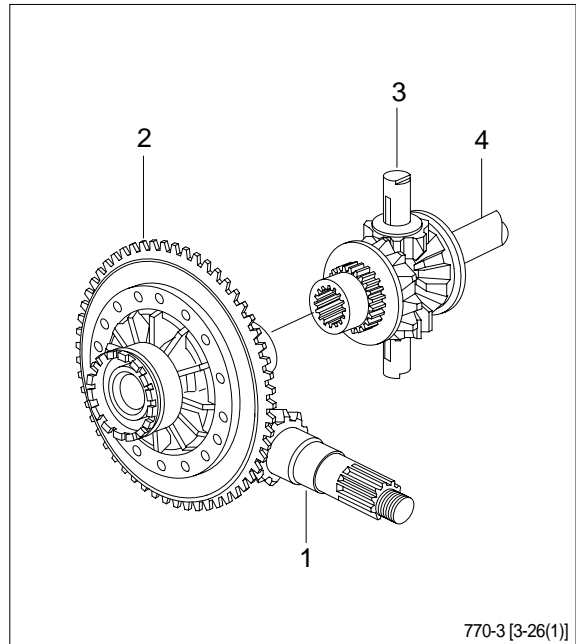

##### (2) When driving straight forward

When the machine is being driven straight forward and the right and left wheels are rotating at the same speed, so the pinion gear inside the differential assembly do not rotate. The motive force of the carrier is sent through the pinion gear and the side gear, therefore the power is equally transmitted to the left and right axle gear shaft.

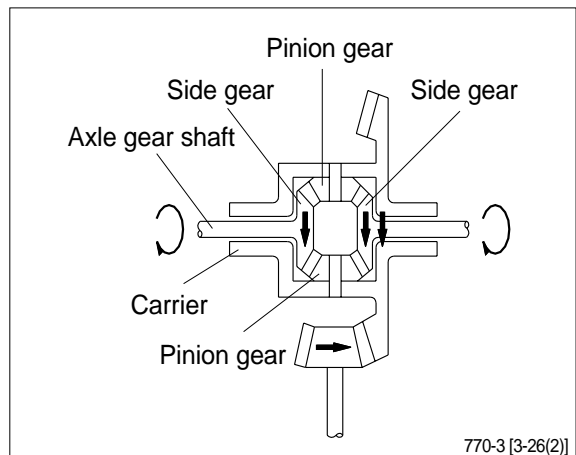

##### (3) When turning

When turning, the rotating speed of the left and right wheels is different, so the pinion gear and side gear inside the differential assembly rotate in accordance with the difference between the rotating speed of the left and right wheels.

The power of the carrier is then transmitted to the axle gear shafts.

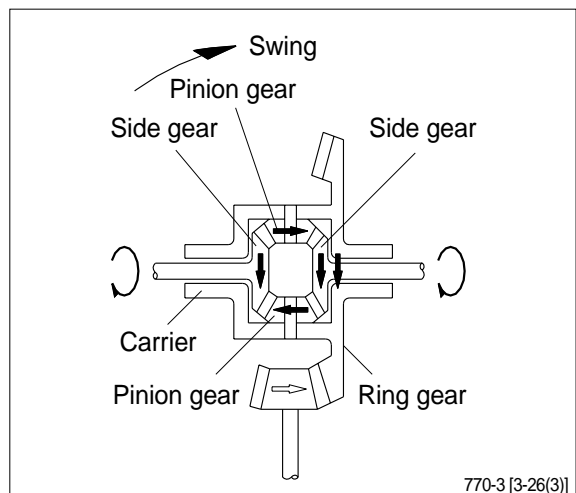

## 5) TORQUE PROPORTIONING DIFFERENTIAL

### (1) Function

- ① Because of the nature of their work, 4-wheel-drive loaders have to work in places where the road surface is bad. In such places, if the tires slip, the ability to work as a loader is reduced, and also the life of the tire is reduced. The torque proportioning differential is installed to overcome this problem. In structure it resembles the differential of an automobile, but the differential pinion gear has an odd number of teeth. Because of the difference in the resistance from the road surface, the position of meshing of the pinion gear and side gear changes, and this changes the traction of the left and right tires.

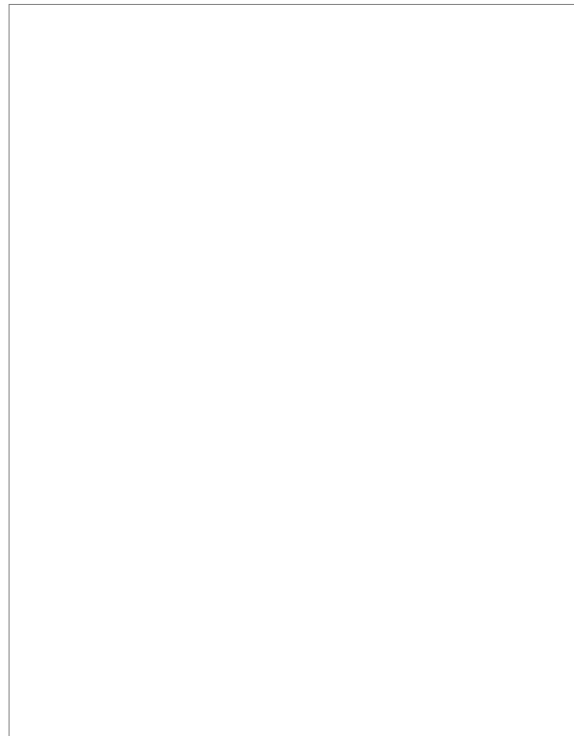

### (2) Operation

#### ① When traveling straight

(Equal resistance from road surface to left and right tires)  
Under this condition, the distances involving the engaging points between right and left side gears and pinion-a and b-are equal and the pinion is balanced as  $FL \times a = FR \times b$ . Thus,  $FL = FR$ , and the right and left side gears are driven with the same force.

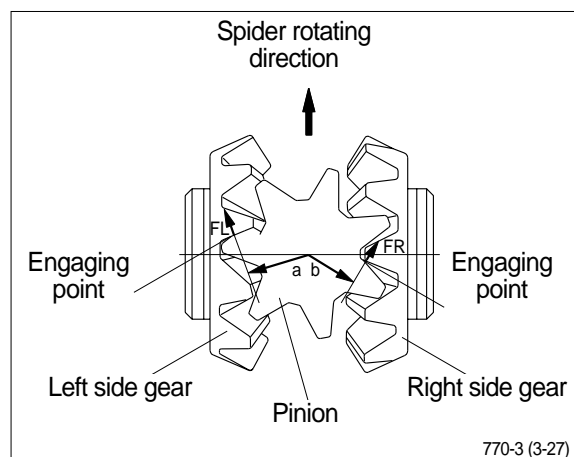

② **When traveling on soft ground**  
(Resistance from road surface to left and right tires is different)

If the road resistance to the left wheel is smaller, the left side gear tends to rotate forward, and this rotation changes the engaging points between the side gears and pinion. As a result, the distances involving the engaging points becomes  $a > b$ . The pinion now is balanced as  $FL \times a = FR \times b$ , where  $FL > FR$ . The right side gear is driven with a greater force than the left side gear. The torque can be increased by up to about 30% for either side gear.

The pinion therefore does not run idle and driving power is transmitted to both side gears until the difference between road resistance to the right and left wheels reaches about 30%.

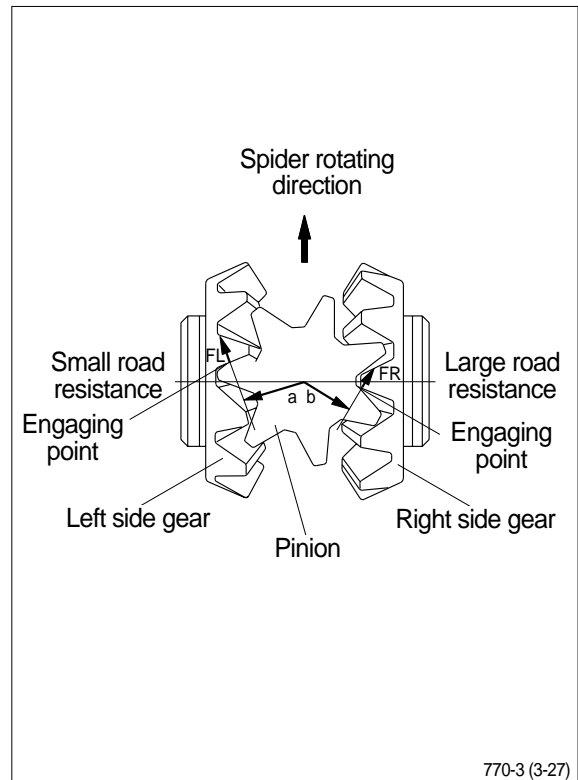

## 6) FINAL DRIVE SECTION(Front & rear)

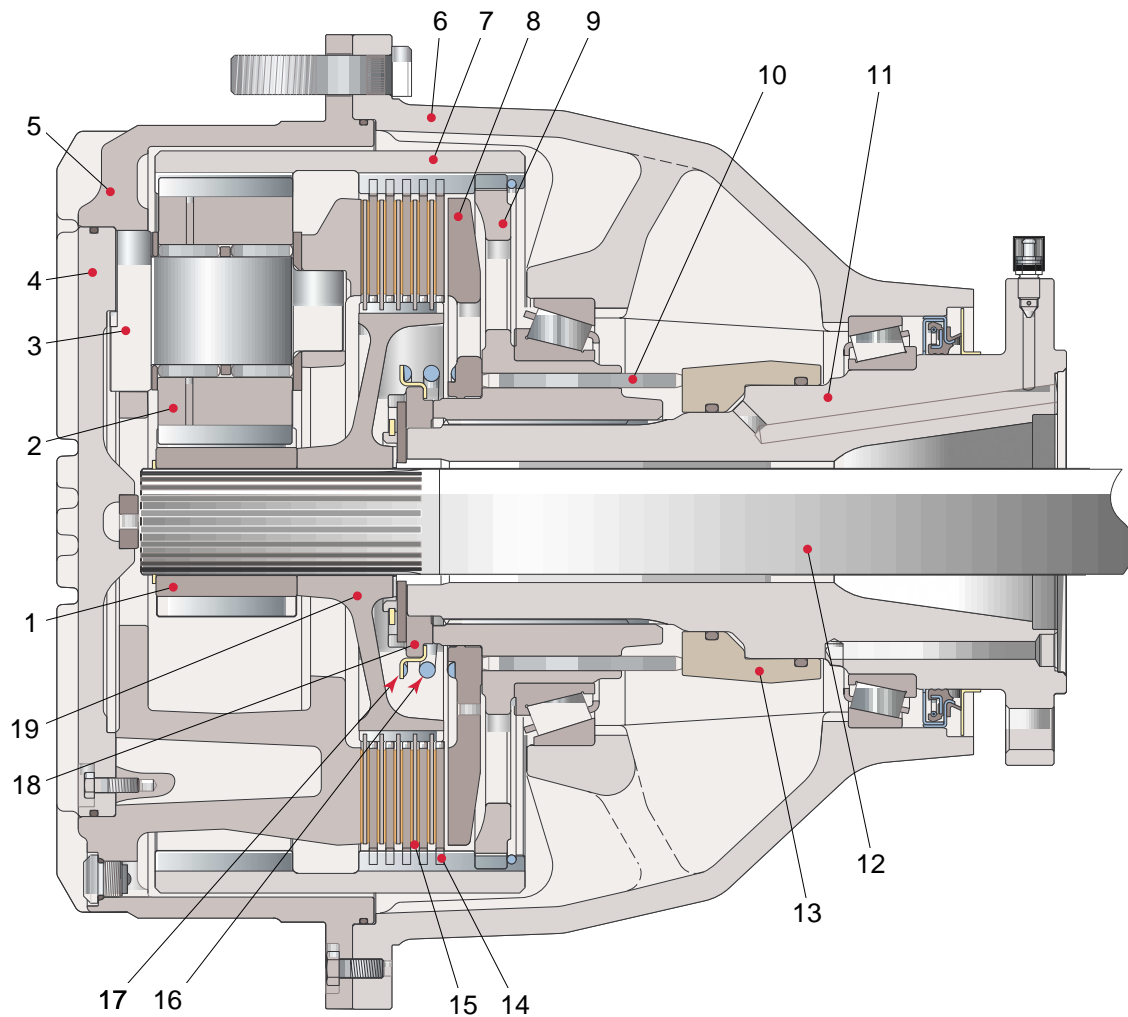

7707PT16

1 Sun gear	8 Pressure plate	14 Lug disc
2 Side gear(Planetary gear)	9 Bevel gear support	15 Brake disc(Friction plate)
3 Side gear carrier pin	10 Pin(Push rod)	16 Piston return spring
4 Final drive cover	11 Spindle	17 Retaining spring ring
5 Side gear carrier support(Hub drum)	12 Half shaft	18 Ring nut
6 Wheel hub	13 Brake drive piston	19 Disc carrier hub
7 Bevel gear(Ring gear)		

(1) To gain a large drive force, the final drive uses a planetary gear system to reduce the speed and send drive force to the tires.

(2) The power transmitted from the differential through axle shaft(12) to sun gear(1) is transmitted to planetary gear(2). The planetary gear rotates around the inside of a fixed ring gear(7) and in this way transmits rotation at a reduced speed to the planetary carrier.

This power is then sent to the wheels which are installed to the planetary carriers.

## 6. TIRE AND WHEEL

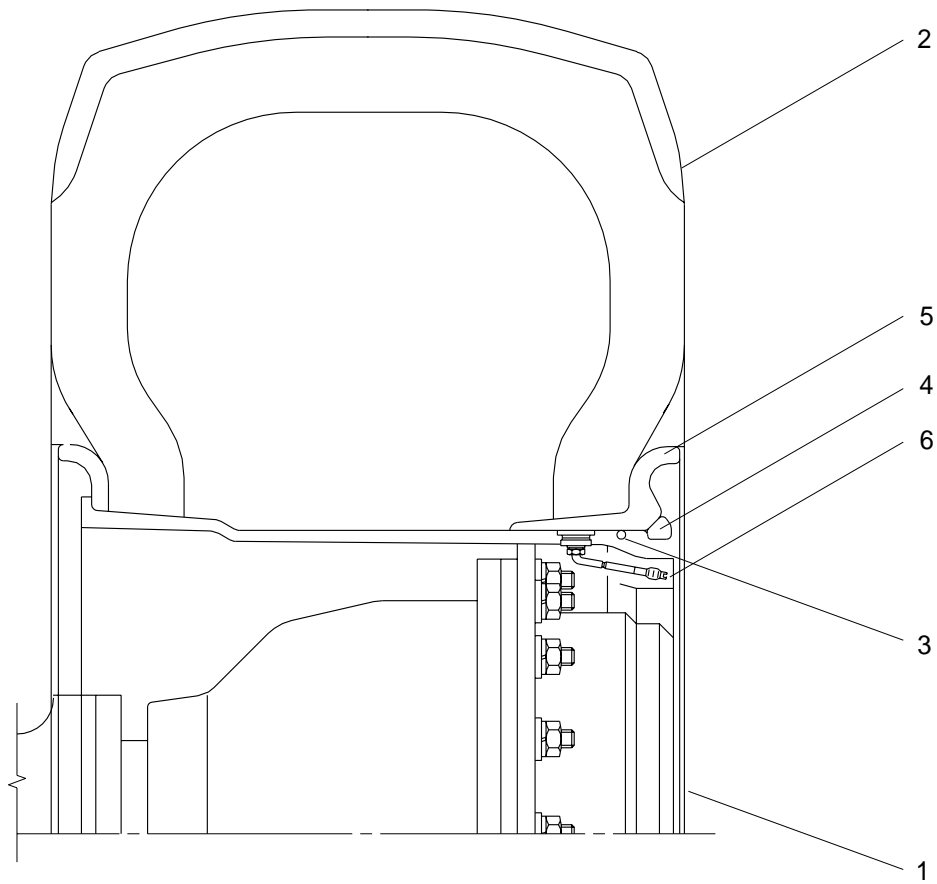

770-3 (3-30)

- |   |           |   |           |   |                |
|---|-----------|---|-----------|---|----------------|
| 1 | Wheel rim | 3 | O-ring    | 5 | Side ring      |
| 2 | Tire      | 4 | Lock ring | 6 | Valve assembly |

- 1) The tire acts to absorb the shock from the ground surface to the machine, and at the same time they must rotate in contact with the ground to gain the power which drives the machine.
- 2) Various types of tires are available to suit the purpose. Therefore it is very important to select the correct tires for the type of work and bucket capacity.