

GROUP 2 ELECTRICAL CIRCUIT

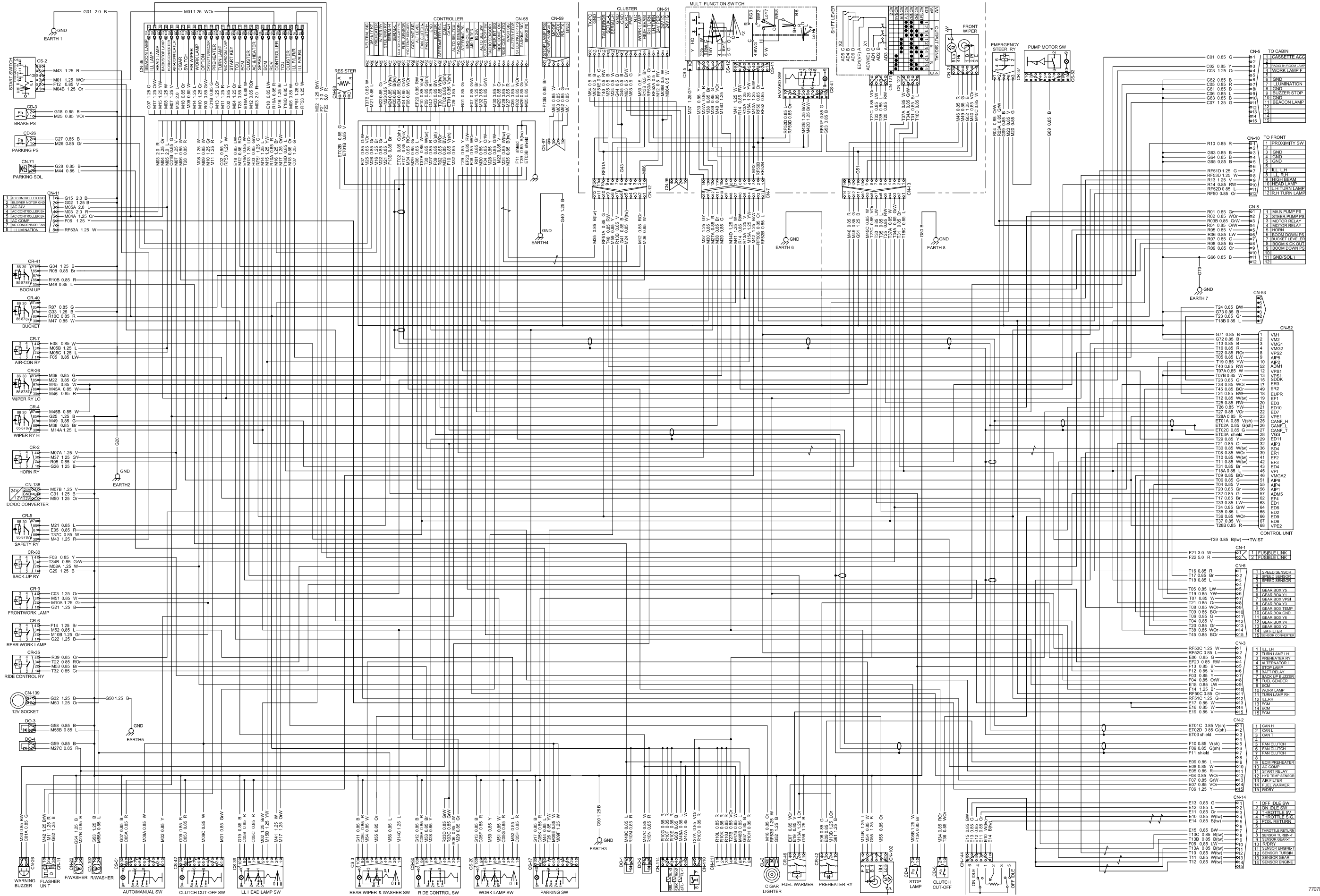

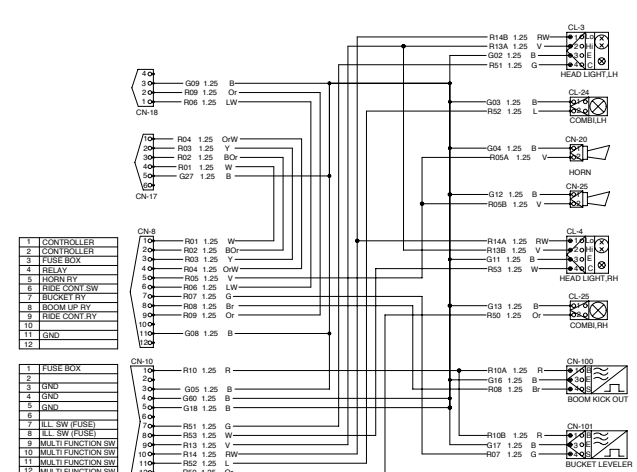

FRONT HARNESS

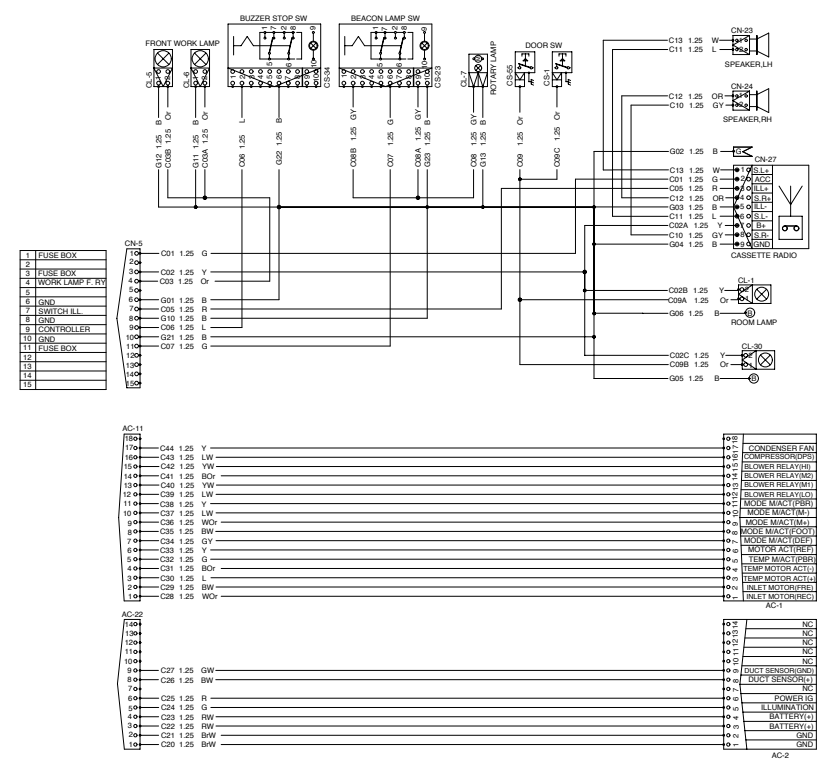

CAB HARNESS

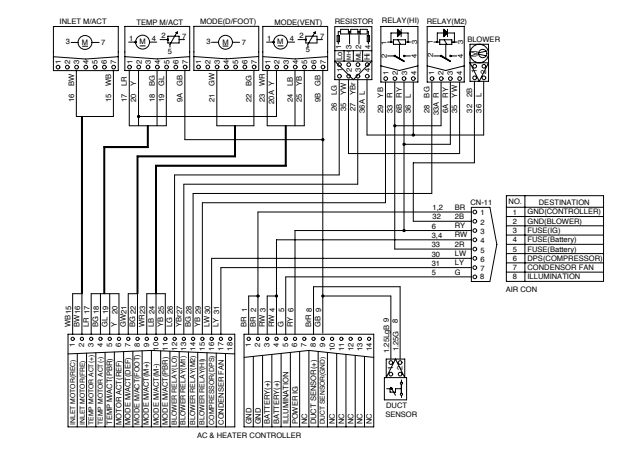

AIR CONDITIONER HARNESS

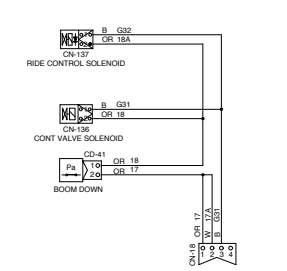

RIDE CONTROL HARNESS

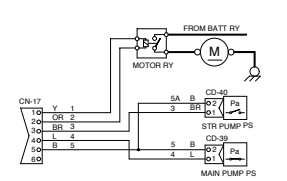

EMERGENCY HARNESS

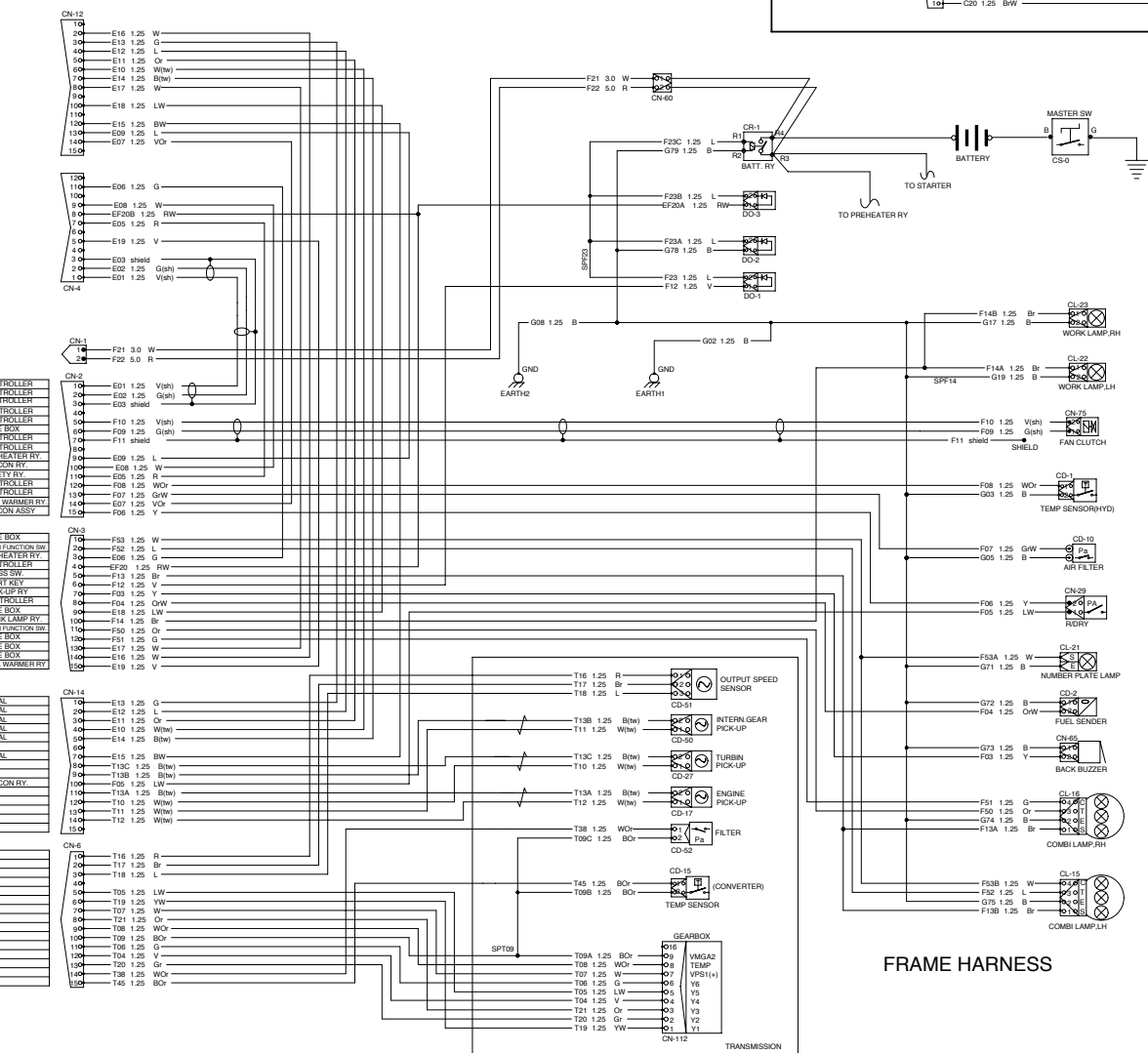

FRAME HARNESS

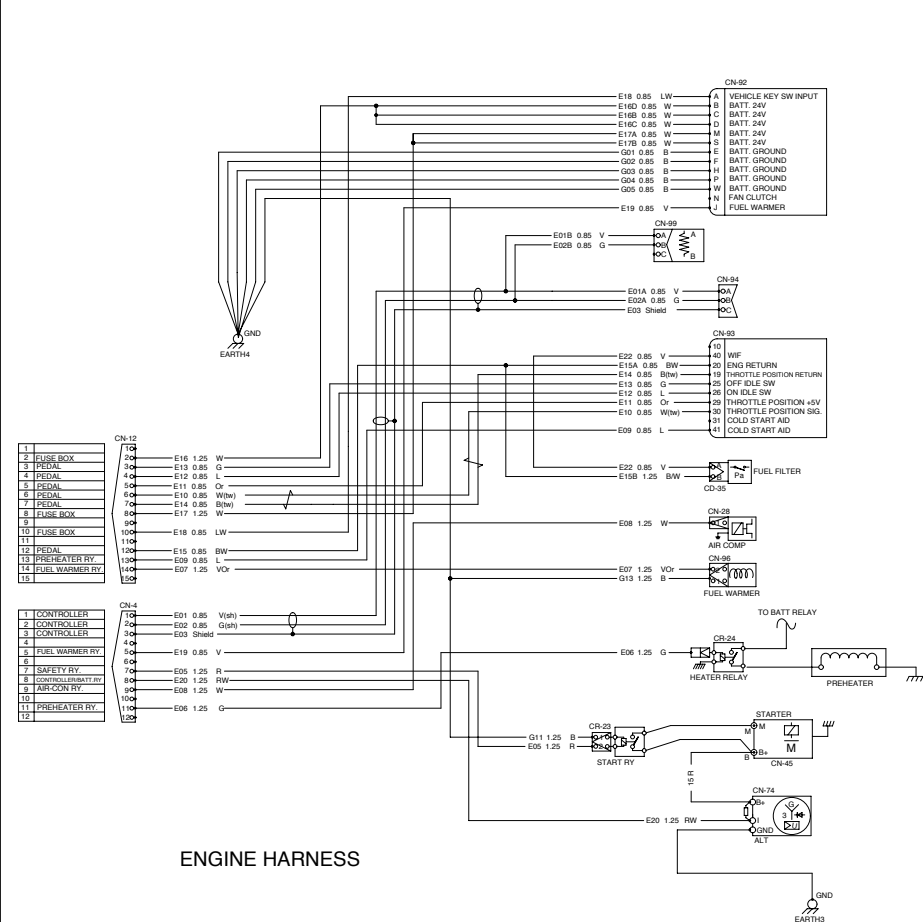

ENGINE HARNESS

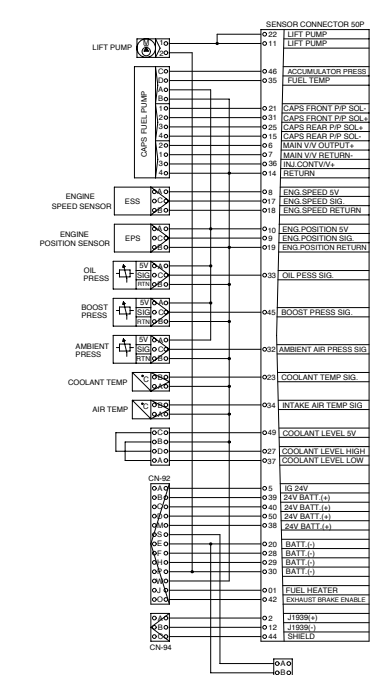

ENGINE HARNESS(CUMMINS)

1. ILLUMINATION CIRCUIT

1) OPERATING FLOW

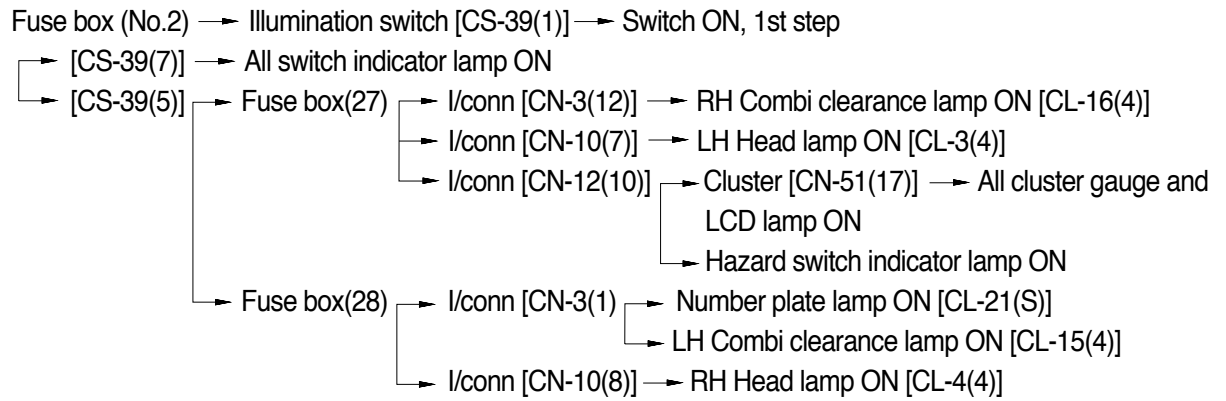

2) CHECK POINT

| Engine | Key switch | Check point | Voltage |
|--------|------------|-----------------------------------------------------------------------------------------|---------|
| OFF | ON | - GND (Switch input) - GND (Switch output) - GND (To light) - GND (To cluster) | 20~25V |

GND : Ground

ILLUMINATION CIRCUIT

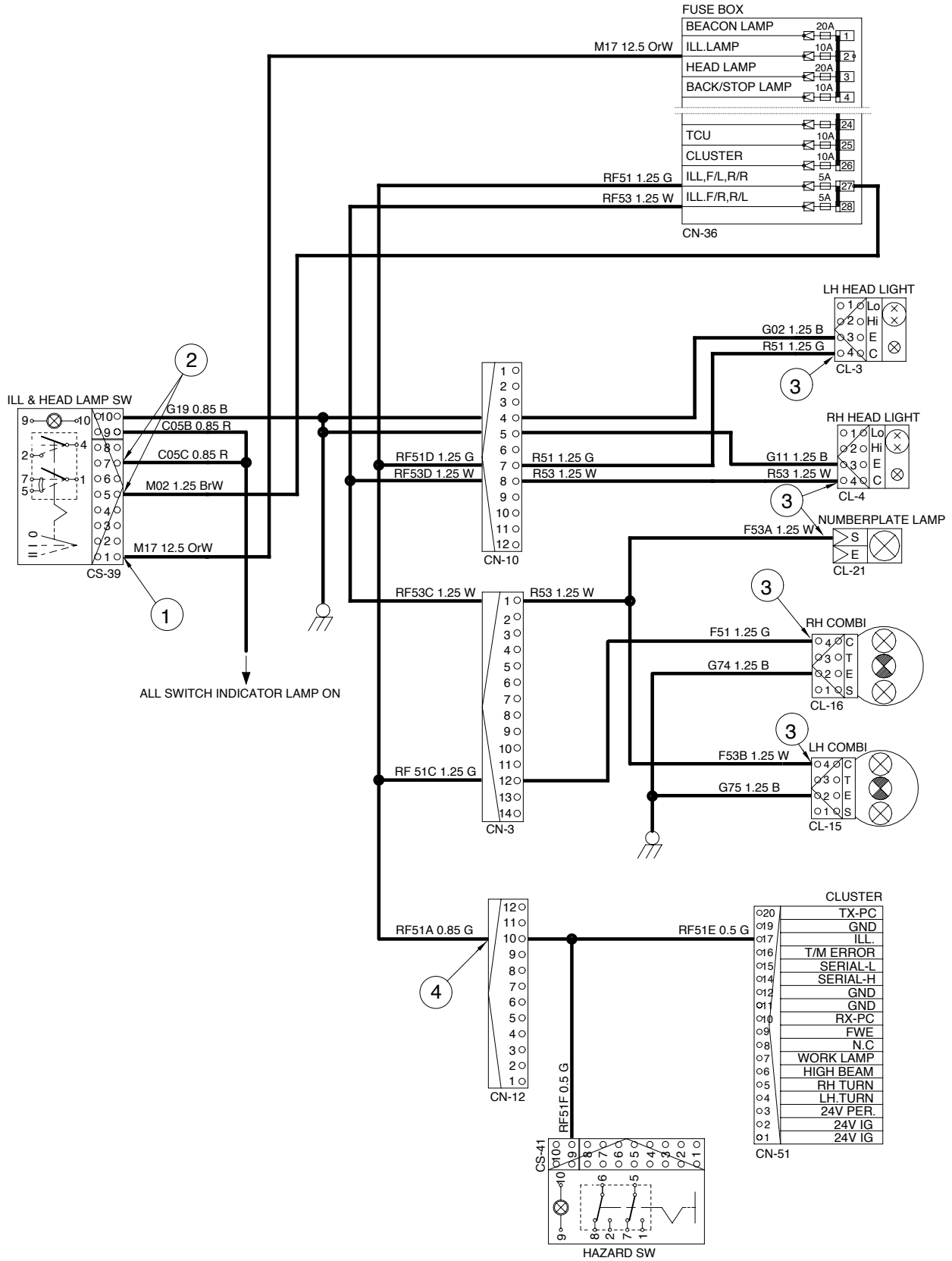

2. HEAD LIGHT CIRCUIT

1) OPERATING FLOW

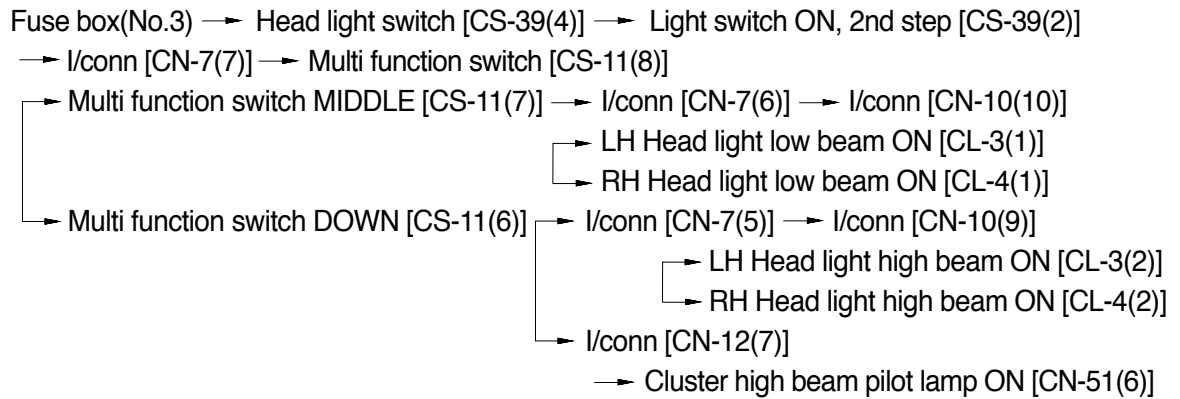

2) CHECK POINT

| Engine | Key switch | Check point | Voltage |
|--------|------------|-----------------------------------------------------------------------------------------------------------------------------------------------------------------------------------------------------------------------------------------------------------------------------------------------------------------------|---------|
| OFF | ON | <ul style="list-style-type: none"> - GND (Switch input) - GND (Switch output) - GND (Multi function input) - GND (Multi function output) - GND (Multi function output) - GND (Low beam) - GND (High beam) - GND (Passing B⁺) | 20~25V |

GND : Ground

HEAD LIGHT CIRCUIT

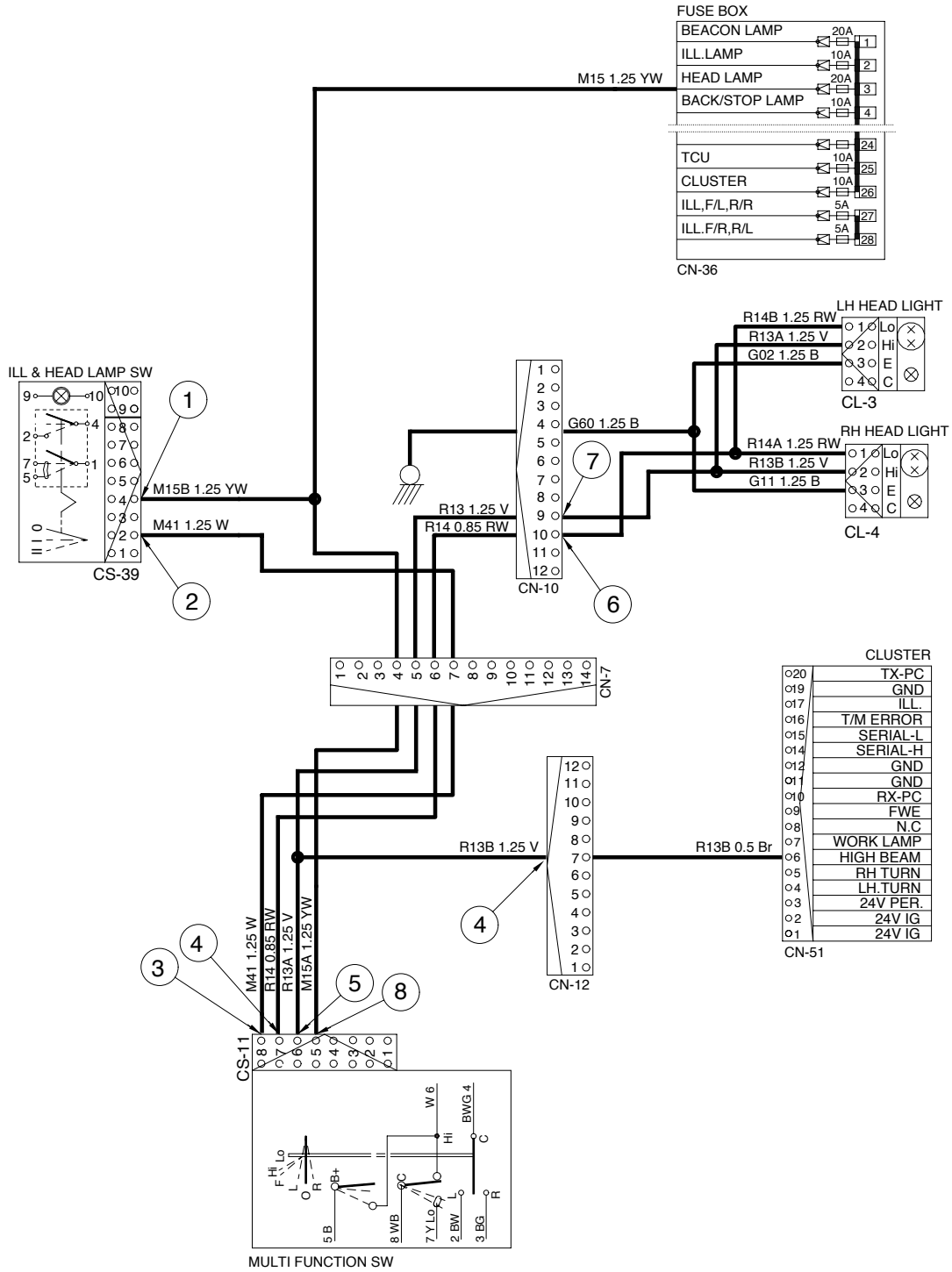

7707EL04

3. WORK LIGHT SWITCH

1) OPERATING FLOW

Illumination switch : ON position

(1) Work lamp switch ON (1st step)

ILL & head lamp switch [CS-39(7)] → work lamp switch [CS-20(1)]

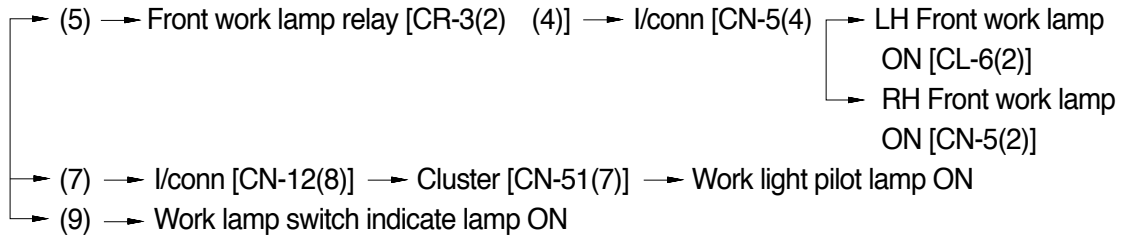

(2) Work lamp switch (2nd step)

Work lamp switch [CS-20(4) (2)] → Rear work lamp relay [CR-6(2) (4)] →

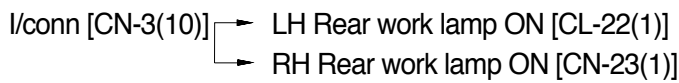

2) CHECK POINT

| Engine | Key switch | Check point | Voltage |
|--------|------------|----------------------------------------------------------------------------------------------------------------------|---------|
| OFF | ON | - GND (Work lamp power input) - GND (Work lamp power output) - GND (Front work lamp) - GND (Rear work lamp) | 20~25V |

GND : Ground

WORK LIGHT SWITCH

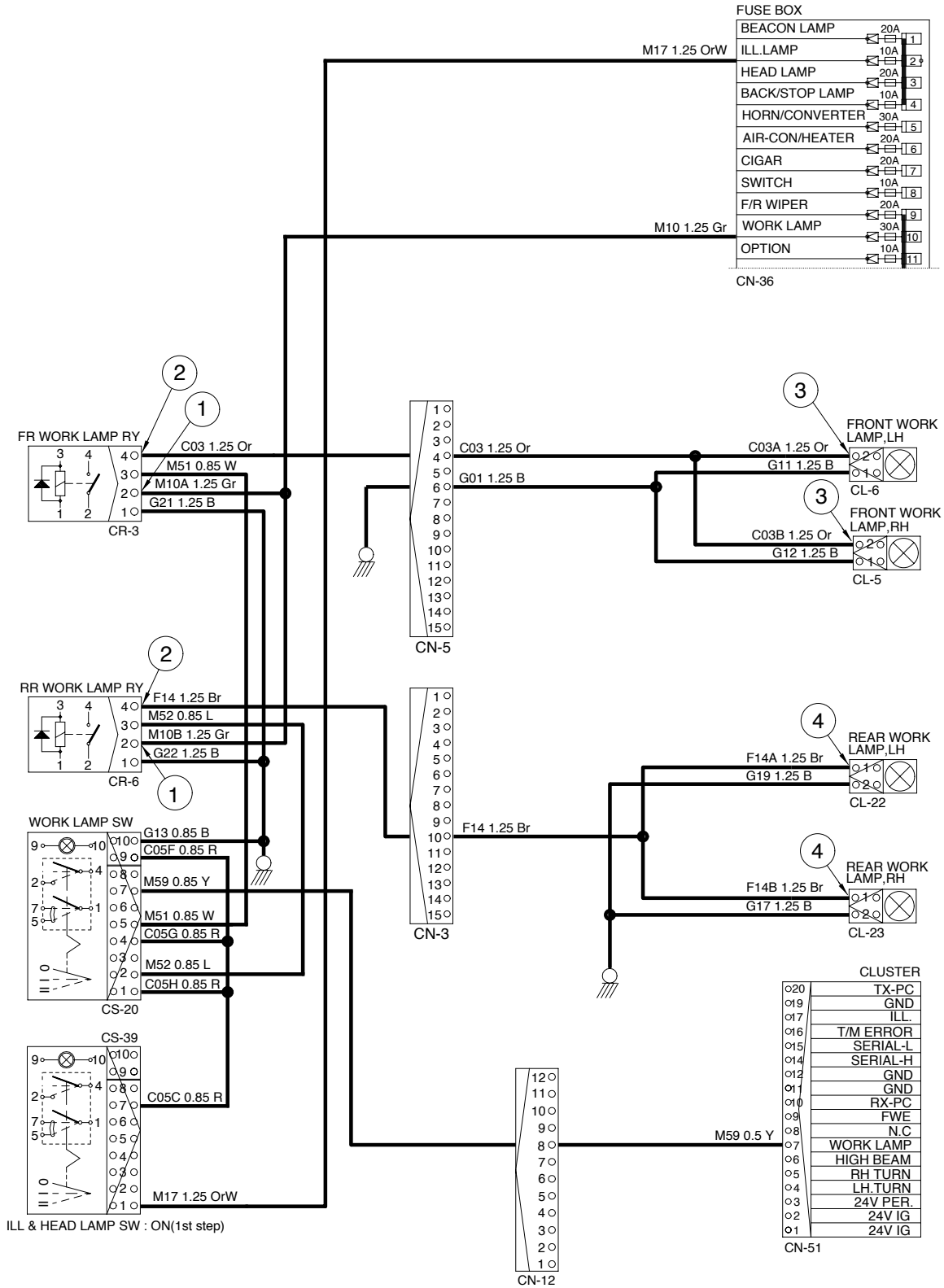

7707EL05

4. STARTING CIRCUIT

1) OPERATING FLOW

Battery(+) terminal → Battery relay(R4 terminal) → Fusible link [CN-60(1)]
 → I/conn [CN-1(1)] → Fuse box (No.15) → Start switch [CS-2(1)]

The gear selector lever is neutral position. It is necessary condition before the starting.

The gear selector has an output signal which is activated whenever the shift lever is in the neutral position. This signal can be used to control a relay and prevent engine from starting whenever the shift lever is not in the neutral position.

(1) When start key switch is in ON position

Start switch ON → Start switch [CS-2(2)] → I/conn [CN-3(6)] → Battery relay [CR-1]
 → Battery relay operating(All power is supplied with the electric component)
 → Start switch [CS-2(3)] → Fuse box [No.23] → Fuse box (No.22) →
 I/conn [CN-3(9)] → I/conn [CN-12(10)] → ECM[CN-92(A)]

(2) When start key switch is in START position

Start switch START [CS-2(5)] → Start safety relay [CR-5(30)] → Start safety relay [CR-5(87)]
 → I/conn [CN-2(11)] → [CN-4(7)] → Start relay [CR-23(2)] →
 Starter(Terminal B⁺ and M connector of start motor)

2) CHECK POINT

| Engine | Key switch | Check point | Voltage |
|---------|------------|----------------------------------------------------------------------------------------------------------------------------------------------------------------------------------------------------------------------------------------------------------------------------------|---------|
| Running | ON | - GND (Battery B ⁺) - GND (Fusible link) - GND (Start key B terminal) - GND (Start key BR terminal) - GND (I/conn CN-3(6)) - GND (Start key ST terminal) - GND (Start safety relay output) - GND (Controller) - GND (Start key ACC terminal) | 20~25V |

GND : Ground

ECM : Electronic control module

STARTING CIRCUIT

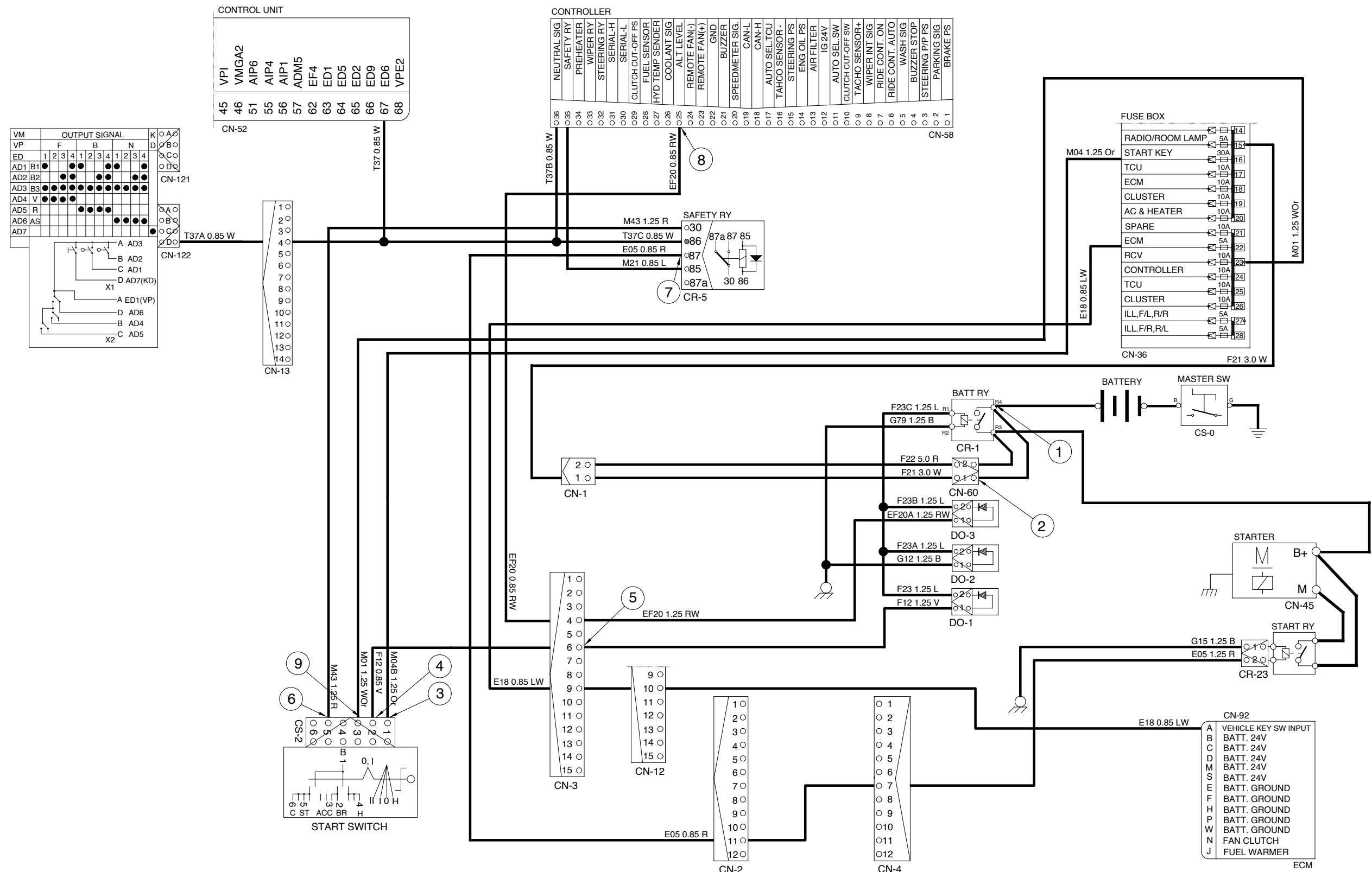

5. ENGINE STOP CIRCUIT

1) OPERATING FLOW

Start key OFF [CS-2(3)] → Fuse box (No.20) → I/conn [CN-2(8)] → I/conn [CN-4(9)]
→ Engine stop solenoid OFF (CN-79)

2) CHECK POINT

| Engine | Key switch | Check point | Voltage |
|--------|------------|---------------------------------------------------------------|---------|
| OFF | OFF | - GND (Start key IG terminal) - GND (Engine stop solenoid) | 0V |

GND : Ground

3) WIRING DIAGRAM - See page 7-12.

6. CHARGING CIRCUIT

When the starter is activated and the engine is started, the operator releases the key switch to the ON position.

Charging current generated by operating alternator flows into the battery through the battery relay (CR-1).

The current also flows from alternator to each electrical component and controller through the fuse box.

1) OPERATING FLOW

(1) Warning flow

Alternator [CN-74(1)] → I/conn [CN-4(8)] → I/conn [CN-3(4)] → Controller [CN-58(25)]
 → Cluster charge warning lamp ON

(2) Charging flow

Alternator → Starter [CN-45(B⁺)] → Battery relay [CR-1]
 ↳ Battery(+) terminal → Charging
 ↳ I/conn [CN-60(1),(2)] → I/conn [CN-1(1),(2)] → Fuse box

2) CHECK POINT

| Engine | Key switch | Check point | Voltage |
|---------|------------|------------------------------------------------------------------------------------------------------------------------------------|---------|
| Running | ON | - GND (Battery) - GND (Battery relay) - GND (ALT B ⁺) - GND (ALT I) - GND (Controller) - GND (Fuse box) | 20~28V |

GND : Ground

CHARGING CIRCUIT

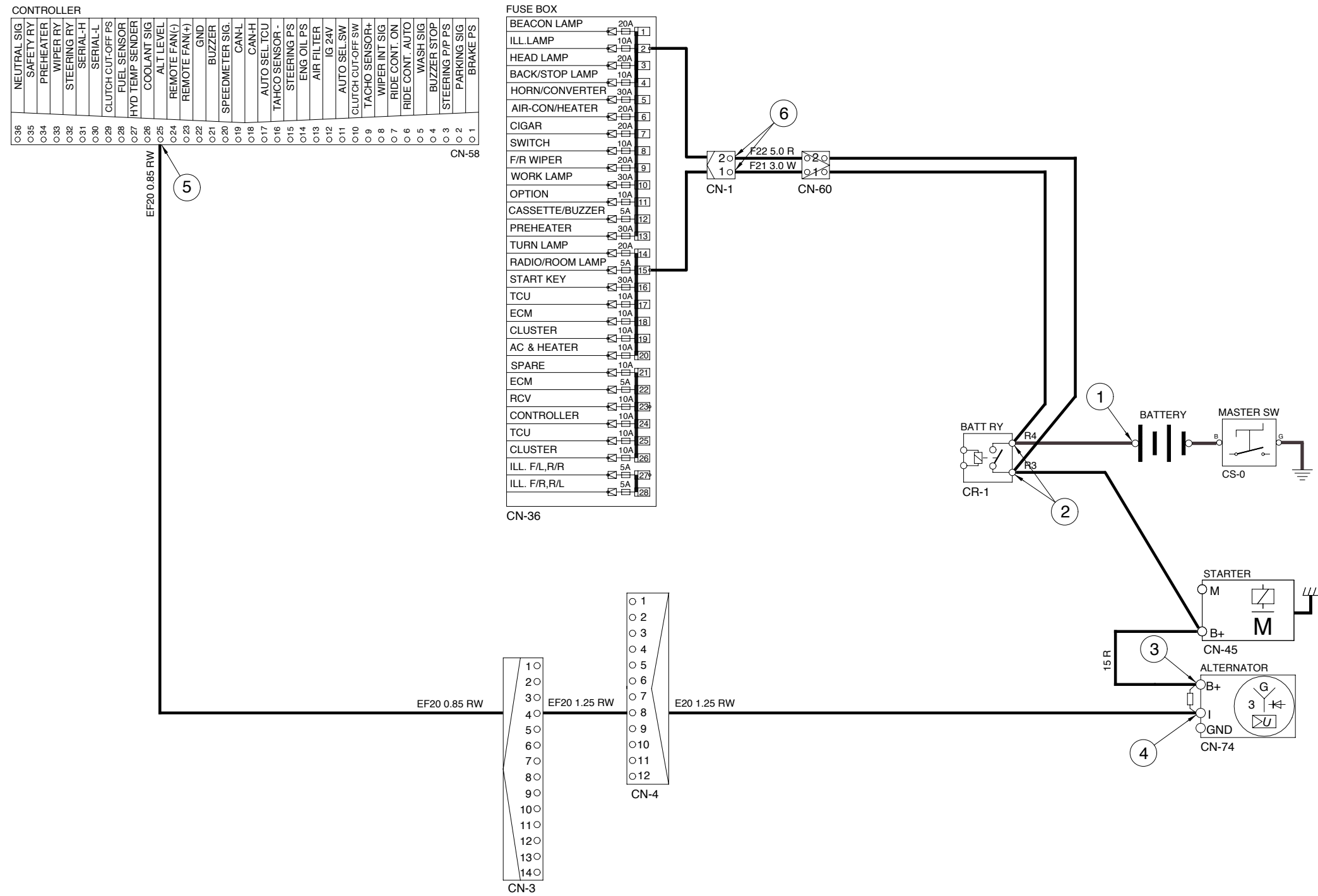

7. ELECTRIC PARKING, DECLUTCH CIRCUIT

1) OPERATING FLOW

(1) Parking OFF

Fuse box (No.8) → Parking switch OFF [CS-17(6)‡ (8)] → Parking solenoid ON (Activated)
 → Parking brake released (By hydraulic pressure)

(2) Parking ON

Fuse box (No.8) → Parking switch ON

- Parking solenoid [CN-71] OFF
 - Parking brake applied [By spring force]
- [CS-17(5)‡ (7)] → T/M control unit [CN-52(21)]
 - T/M declutch

(3) Declutch ON

Fuse box (No.8) → Clutch cut-off switch ON → Clutch cut-off switch [CS-42(5) ‡ (1)] →
 → Controller [CN-58(10)‡ (29)] → Service brake applied → Service brake pressure switch
 ON [CD-5] → T/M control unit [CN-52(66)] → Declutch

2) CHECK POINT

| Engine | Key switch | Check point | Voltage |
|---------|------------|------------------------------------------------------------------------------------------------------------------------------------------------------------------------------------------------------|---------|
| Running | ON | - GND (Parking switch input) - GND (Parking switch output) - GND (Parking switch input) - GND (Parking switch output) - GND (Parking solenoid) - GND (Pressure switch clutch cut-off) | 20~25V |

GND : Ground

ELECTRIC PARKING, DECLUTCH CIRCUIT

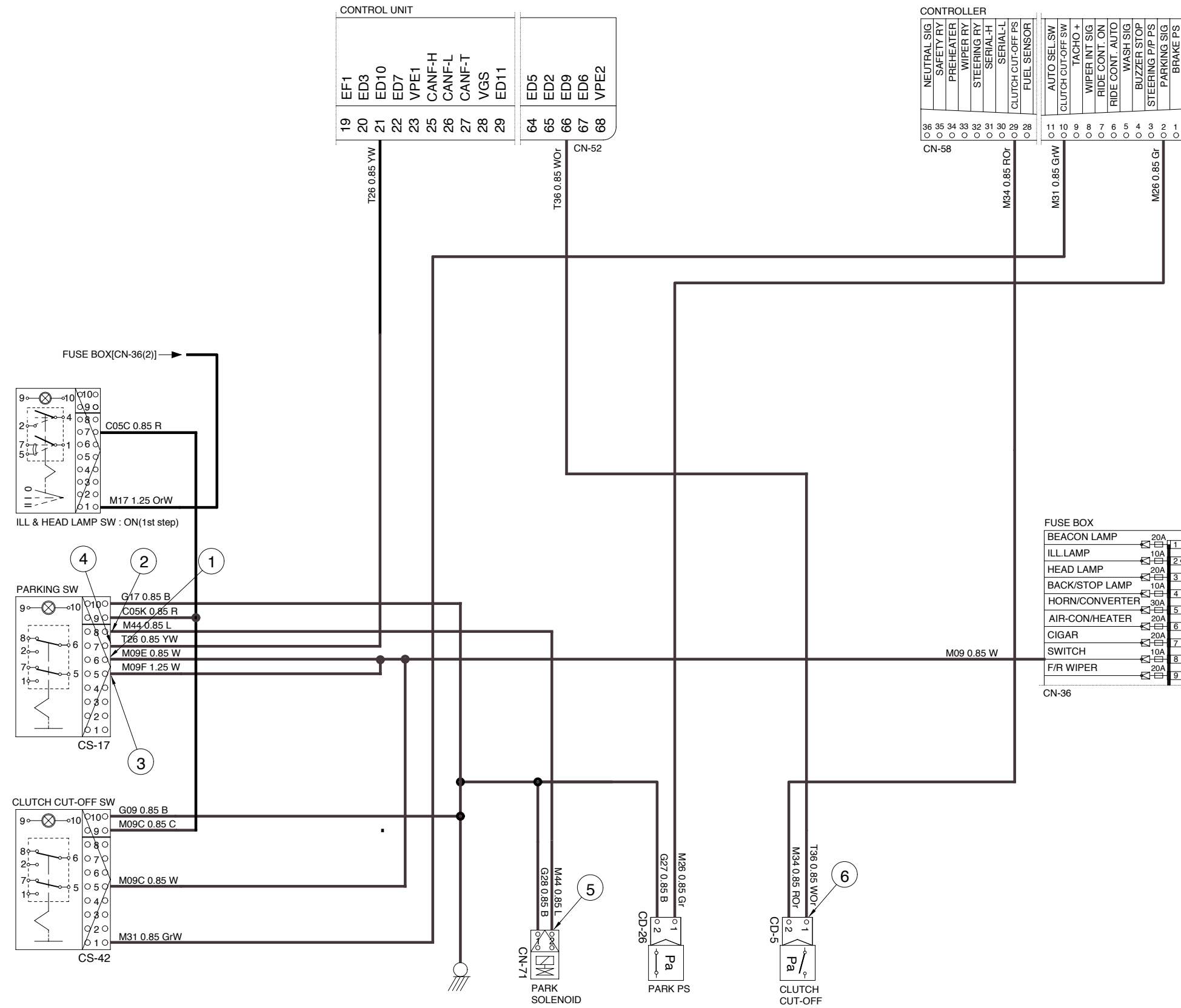

8. WIPER AND WASHER CIRCUIT

1) OPERATING FLOW

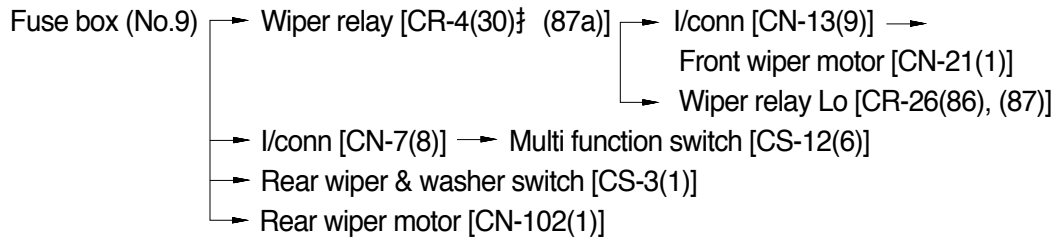

(1) Front washer switch ON

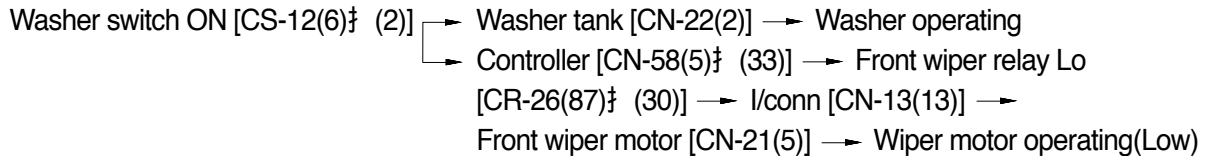

(2) Front wiper switch ON

INT position

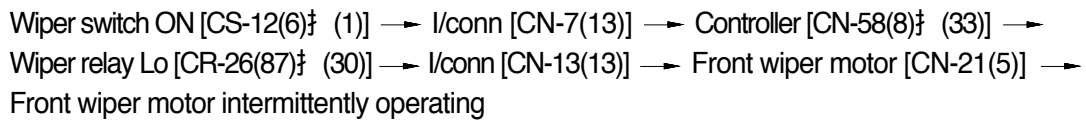

Lo position

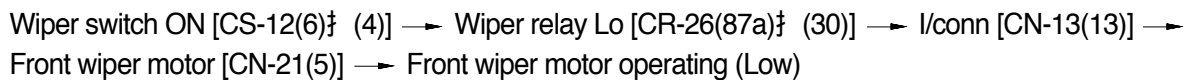

Hi position

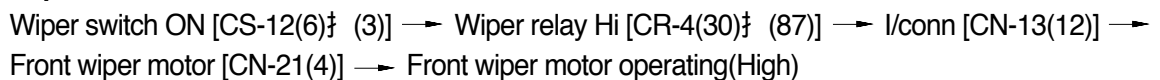

(3) Auto-parking(When switch OFF)

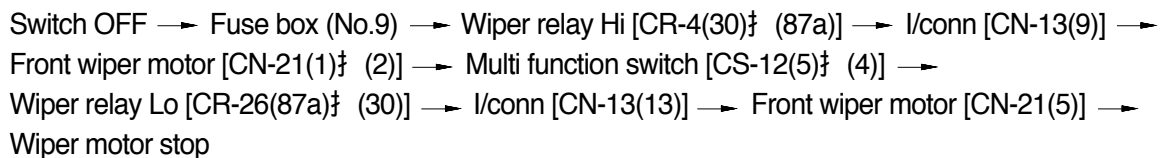

(4) Rear wiper and washer switch

Wiper switch ON(1st step)

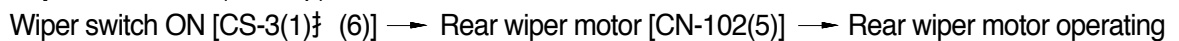

Washer switch ON(2nd step)



2) CHECK POINT

| Engine | Key switch | Check point | Voltage |
|--------|------------|----------------------------------------------------------------------------------------------------------------------------------------------------------------------------------------------------------------------------------------------------------------------------------------------------------------------------------------------------------------------------------------------------------------------------------------------------------------------------------------------------------|---------|
| Stop | ON | <ul style="list-style-type: none">- GND (Front wiper switch power input)- GND (Rear wiper switch power input)- GND (Wiper relay power input)- GND (Front wiper motor Lo power input)- GND (Front wiper motor High power input)- GND (Wiper relay power input)- GND (Front washer power output)- GND (Rear washer power output)- GND (Front wiper motor power output)- GND (Rear wiper motor power output) | 20~25V |

GND : Ground

WIPER AND WASHER CIRCUIT

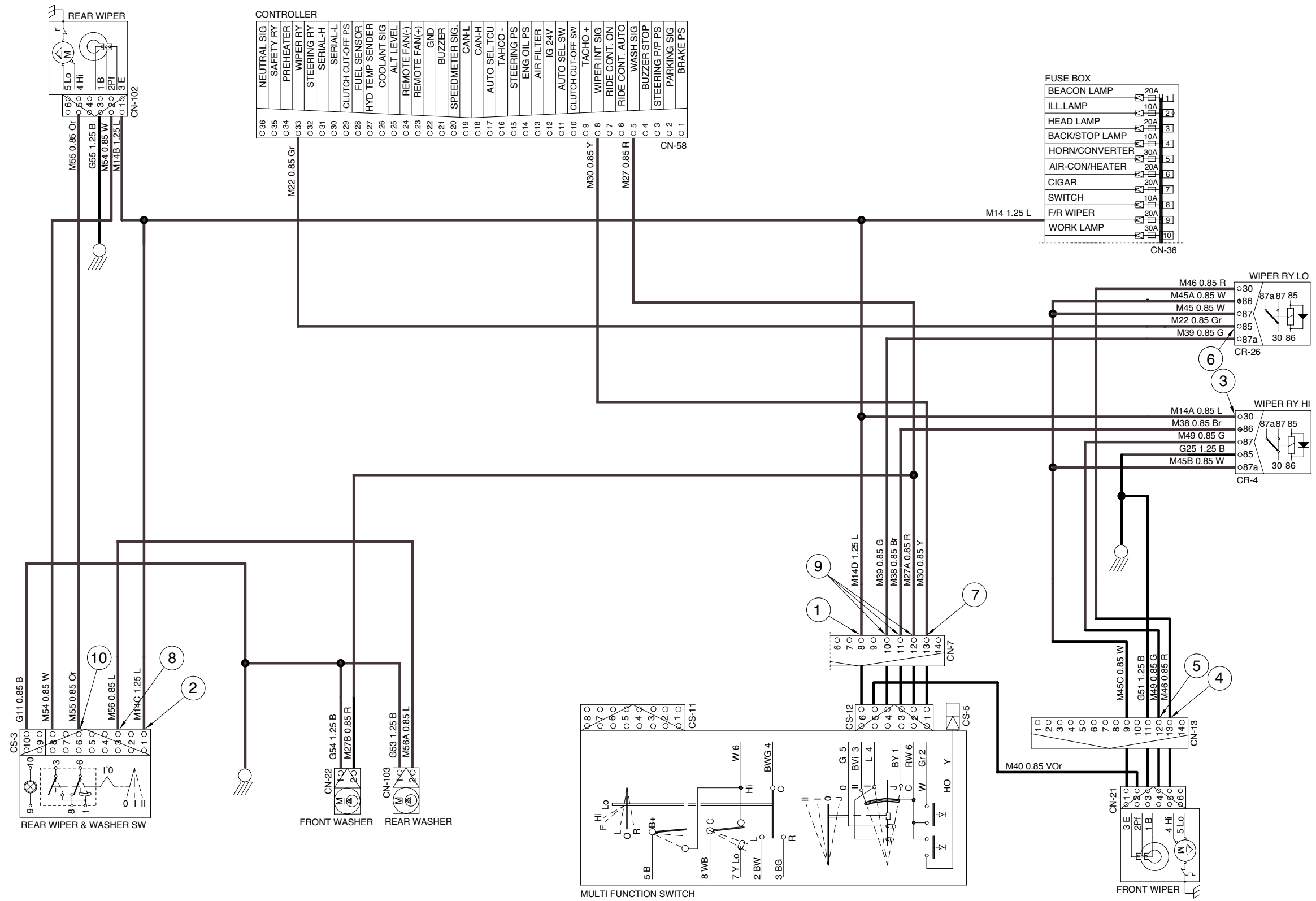

HAZARD, TURN AND ROTARY CIRCUIT

