

GROUP 2 SPECIFICATION

1. MAJOR COMPONENT

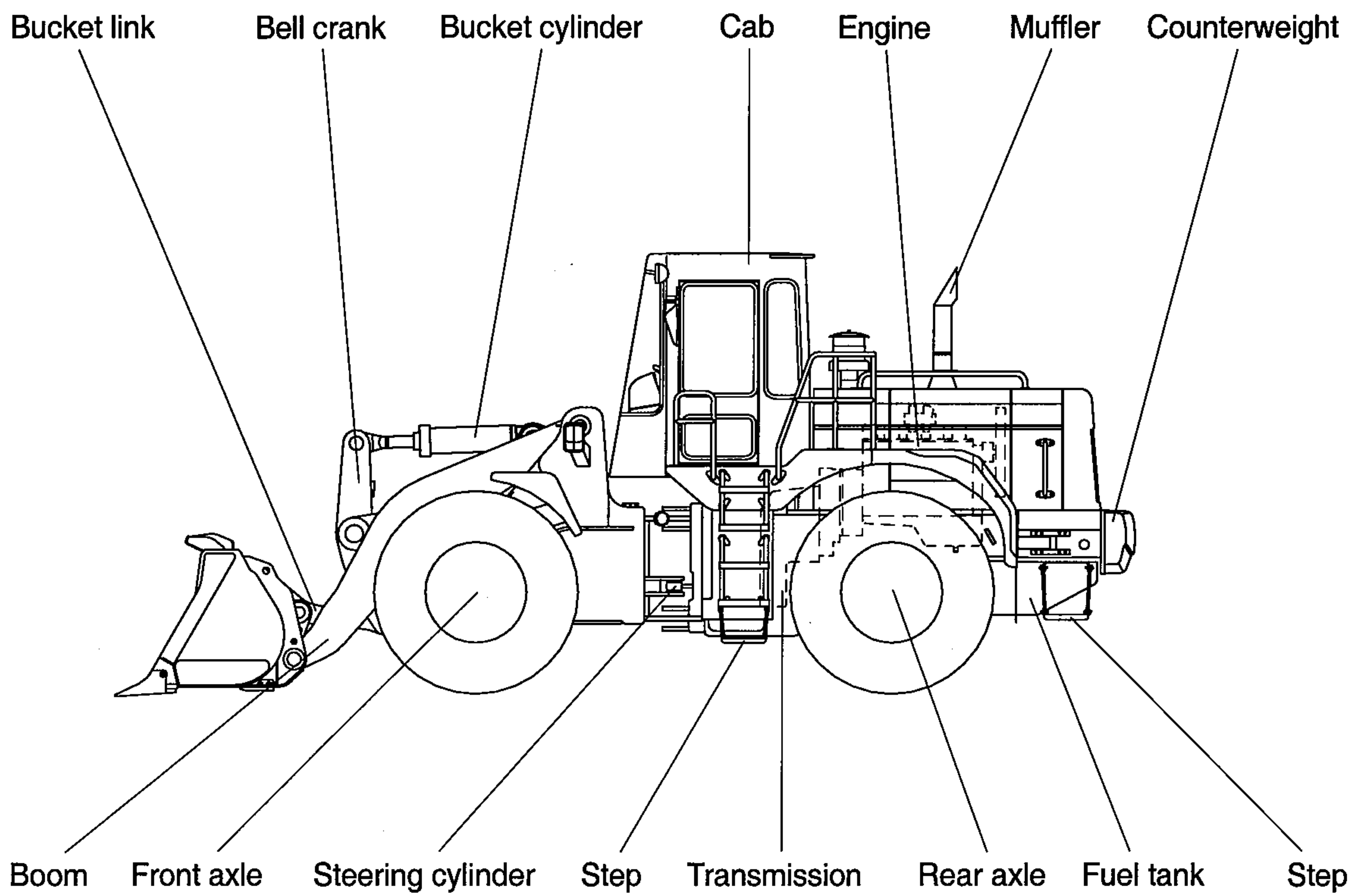
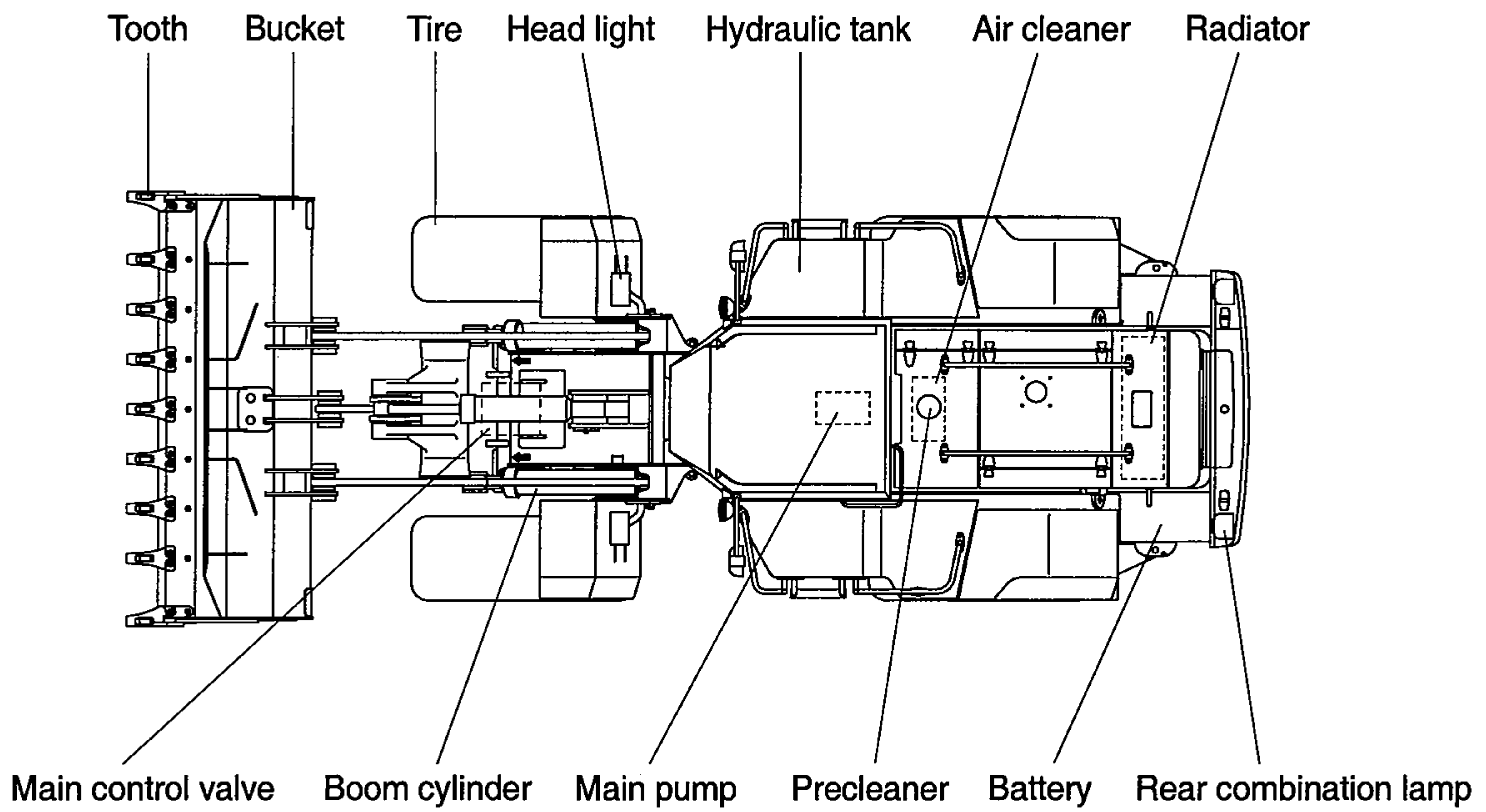

2. SPECIFICATIONS

1) WITHOUT TOOTH AND CUTTING EDGE TYPE BUCKET

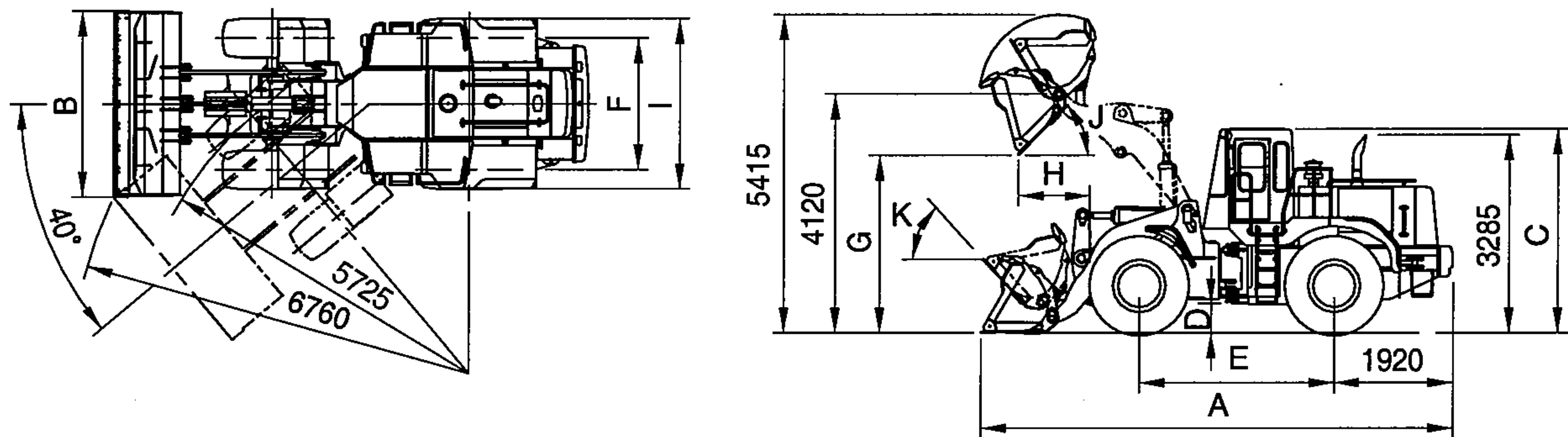

Description		Unit	Specification
Operating weight		kg(lb)	17660(38930)
Bucket capacity	Struck	m ³ (yd ³)	2.6(3.4)
	Heaped		3.0(3.9)
Overall length	A	mm(ft-in)	7860(25' 9")
Overall width	B		3100(10' 2")
Overall height	C		3460(11' 4")
Ground clearance	D		420(1' 5")
Wheelbase	E		3300(10' 10")
Tread	F		2160(7' 1")
Dump clearance at 45°	G		3080(10' 1")
Dump reach	H		1130(3' 8")
Width over tires	I		2770(9' 1")
Dump angle	J		Degree (°)
Roll back angle(carry position)	K	47.8	
Cycle time	Lift(with load)	sec	6.6
	Dump(with load)		1.5
	Lower(empty)		3.0
Maximum travel speed		km/hr(mph)	36(22)
Braking distance		m(ft-in)	11(36' 1")
Minimum turning radius(outside bucket)			6.76(22' 2")
Gradability		Degree (°)	30
Travel speed	Forward	First gear	7.6(4.7)
		Second gear	12.8(8.0)
		Third gear	23.6(14.7)
		Fourth gear	36.0(22.4)
	Reverse	First gear	8.0(5.0)
		Second gear	13.5(8.4)
Third gear		24.7(15.4)	

2) BOLT-ON CUTTING EDGE TYPE BUCKET

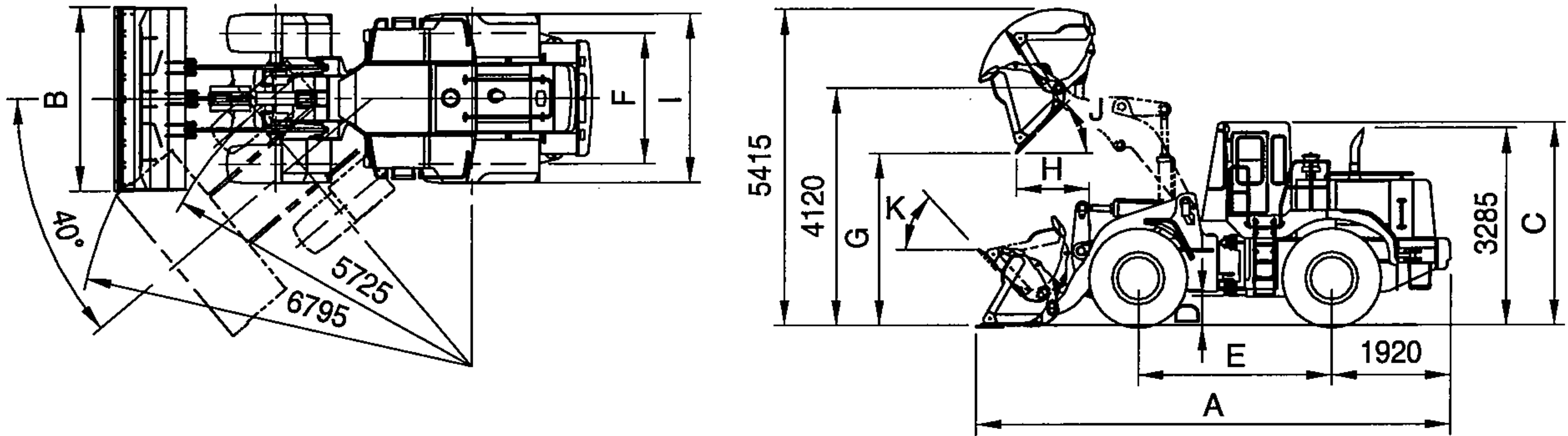

76032SE03

Description		Unit	Specification	
Operating weight		kg(lb)	17900(39460)	
Bucket capacity	Struck	m ³ (yd ³)	2.7(3.5)	
	Heaped		3.1(4.1)	
Overall length	A	mm(ft-in)	7945(26' 1")	
Overall width	B		3100(10' 2")	
Overall height	C		3460(11' 4")	
Ground clearance	D		420(1' 5")	
Wheelbase	E		3300(10' 10")	
Tread	F		2160(7' 1")	
Dump clearance at 45°	G		3022(9' 11")	
Dump reach	H		1190(3' 11")	
Width over tires	I		2770(9' 1")	
Dump angle	J		Degree (°)	45
Roll back angle(carry position)	K			47.8
Cycle time	Lift(with load)	sec	6.6	
	Dump(with load)		1.5	
	Lower(empty)		3.0	
Maximum travel speed		km/hr(mph)	36(22)	
Braking distance		m(ft-in)	11(36' 1")	
Minimum turning radius(outside bucket)			6.8(22' 4")	
Gradability		Degree (°)	30	
Travel speed	Forward	km/hr(mph)	First gear	7.6(4.7)
			Second gear	12.8(8.0)
			Third gear	23.6(14.7)
			Fourth gear	36.0(22.4)
	Reverse		First gear	8.0(5.0)
			Second gear	13.5(8.4)
Third gear		24.7(15.4)		

3) WITH TOOTH TYPE BUCKET

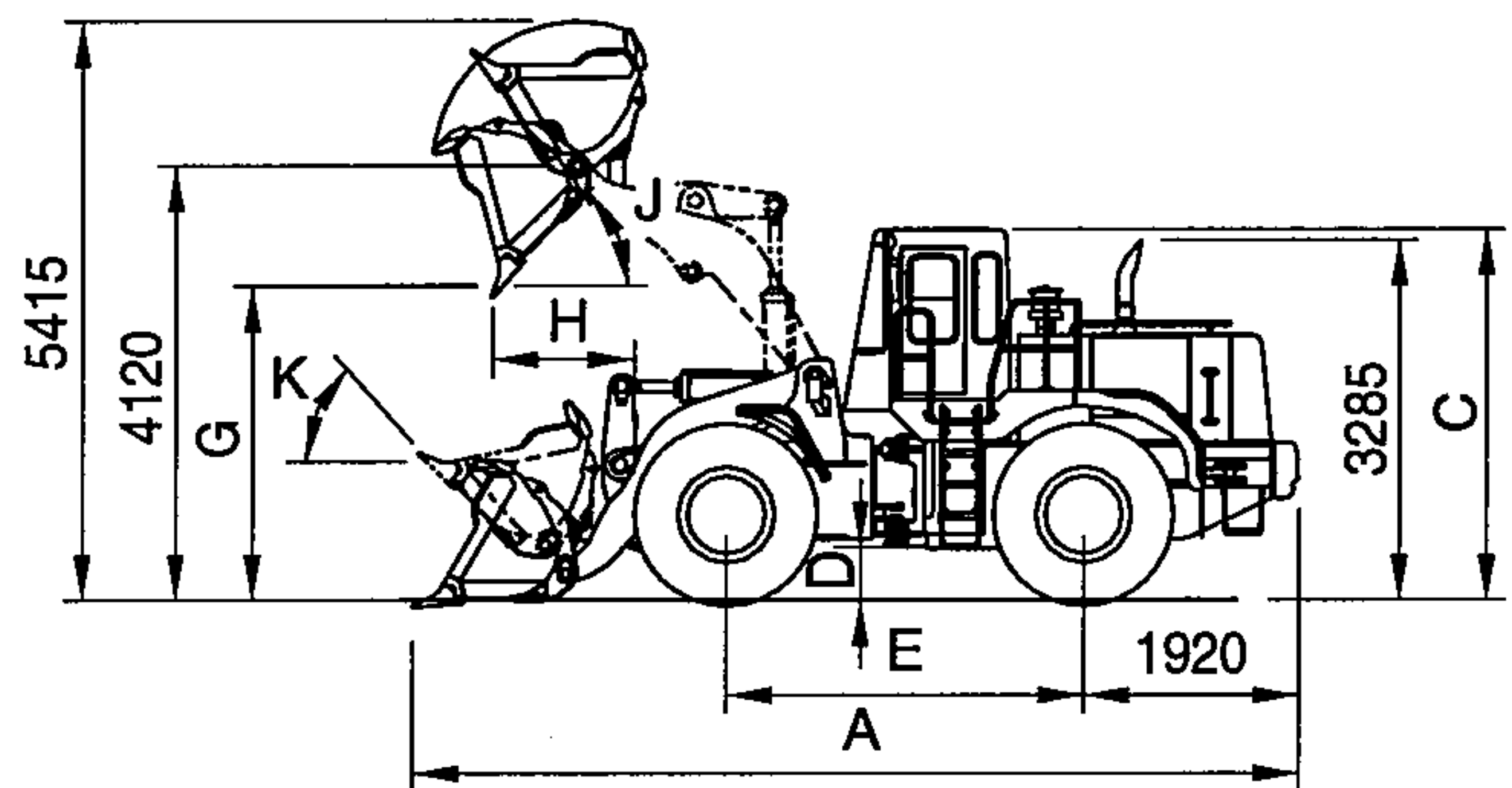
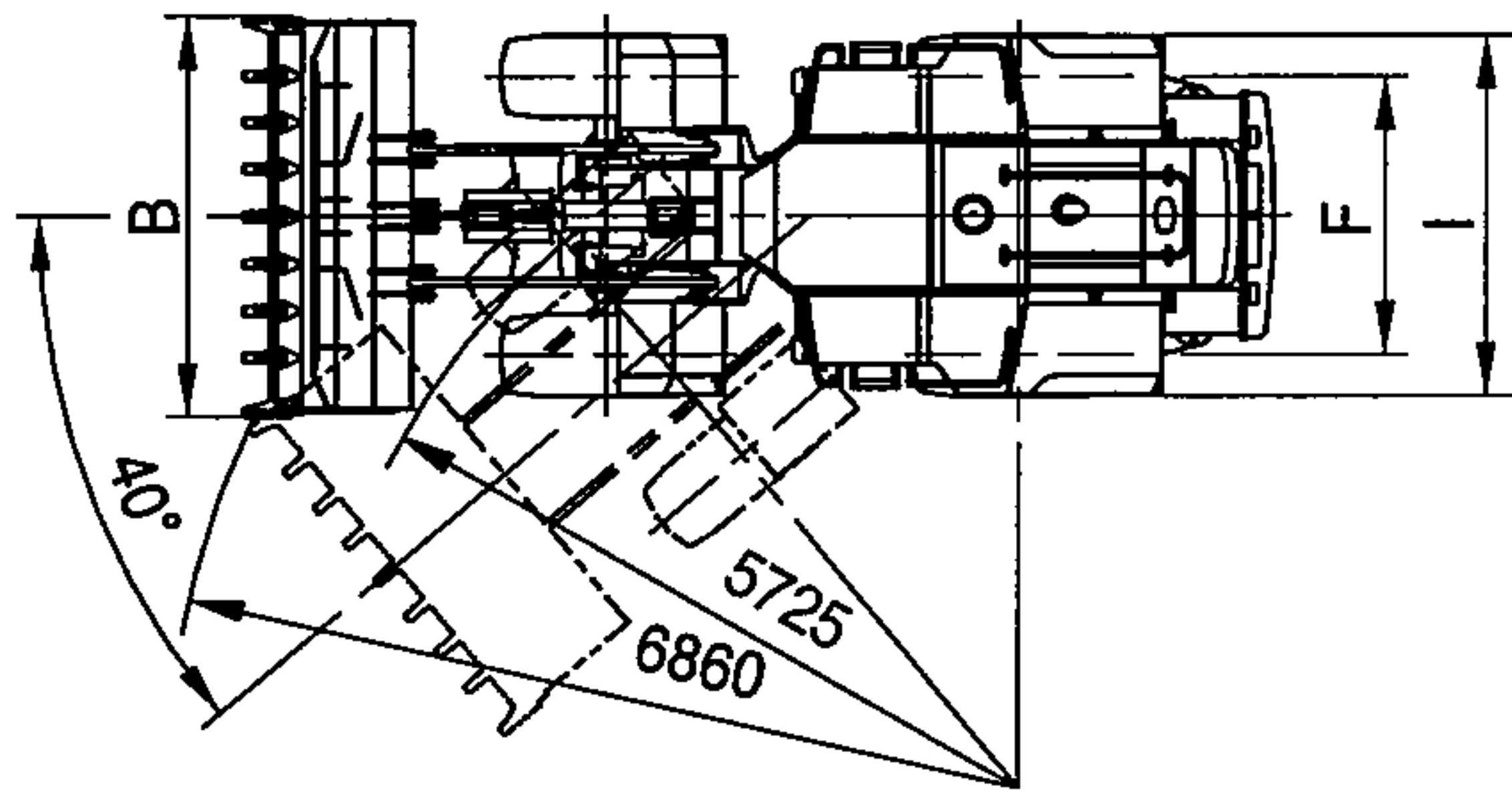

76032SE04

Description		Unit	Specification	
Operating weight		kg(lb)	17820(39290)	
Bucket capacity	Struck	m ³ (yd ³)	2.6(3.4)	
	Heaped		3.0(3.9)	
Overall length	A	mm(ft-in)	8085(26' 6")	
Overall width	B		3150(10' 4")	
Overall height	C		3460(11' 4")	
Ground clearance	D		420(1' 5")	
Wheelbase	E		3300(10' 10")	
Tread	F		2160(7' 1")	
Dump clearance at 45°	G		2904(9' 6")	
Dump reach	H		1268(4' 2")	
Width over tires	I		2770(9' 1")	
Dump angle	J		Degree (°)	45
Roll back angle(carry position)	K	47.8		
Cycle time	Lift(with load)	sec	6.6	
	Dump(with load)		1.5	
	Lower(empty)		3.0	
Maximum travel speed		km/hr(mph)	36(22)	
Braking distance		m(ft-in)	11(36' 1")	
Minimum turning radius(outside bucket)			6.9(22' 6")	
Gradability		Degree (°)	30	
Travel speed	Forward	km/hr(mph)	First gear	7.6(4.7)
			Second gear	12.8(8.0)
			Third gear	23.6(14.7)
			Fourth gear	36.0(22.4)
	Reverse		First gear	8.0(5.0)
			Second gear	13.5(8.4)
Third gear		24.7(15.4)		

3. WEIGHT

Item	kg	lb
Front frame assembly	1723	3799
Rear frame assembly	1928	4250
Front fender	86	190
Rear fender	147	324
Counterweight	720	1587
Cab	580	1279
Engine assembly	617	1360
Transmission	470	1036
Drive shaft(T/M to F/D Front)	67	148
Drive shaft(T/M to F/D, Rear)	19	42
Front axle(Include differential)	920	2028
Rear axle(Include differential)	801	1766
Tire	1980	4365
Hydraulic tank	237	522
Fuel tank	300	661
Main pump assembly	21	46
Main control valve	34	75
Boom	1333	2939
Bell crank	305	672
Bucket link	58	128
3.1m ³ bucket, with bolt on cutting edge	1568	3457
3.0m ³ bucket, with tooth	1638	3611
3.0m ³ bucket, without tooth and cutting edge	1325	2921
Boom cylinder assembly	176	388
Bucket cylinder assembly	175	386
Steering cylinder assembly	27	60
Air tank	147	324
Seat	40	88
Battery	88	194

4. SPECIFICATION FOR MAJOR COMPONENTS

1) ENGINE

Item	Specification
Model	Cummins C8.3-C
Type	4-cycle turbocharged diesel engine
Cooling method	Water cooling
Number of cylinders and arrangement	6 cylinders, in-line
Firing order	1-5-3-6-2-4
Combustion chamber type	Direct injection type
Cylinder bore × stroke	114 × 135mm(4.49" × 5.32")
Piston displacement	8270cc(505cu in)
Compression ratio	17.3 : 1
Rated gross horse power	218ps at 2200rpm
Maximum gross torque at 1500rpm	89kgf · m(644lbf · ft)
Engine oil quantity	22.4 l (5.9U.S. gal)
Dry weight	588kg(1296lb)
High idling speed	2370 ± 50rpm
Low idling speed	800 ± 50rpm
Rated fuel consumption	171g/ps · hr
Starting motor	Delco Remy 37MT(24V)
Alternator	DAC HC60(24V-60Amp)
Battery	2 × 12V × 160Ah

2) MAIN PUMP

Item	Specification
Type	Fixed displacement tandem gear pump
Capacity	2 × 63cc/rev
Maximum operating pressure	200kg/cm ² (2840psi)
Rated oil quantity	2 × 136 l /min (35.9U.S. gpm/29.9U.K. gpm)
Rated speed	2100rpm

3) BRAKE PUMP

Item	Specification
Type	Fixed displacement tandem gear pump
Capacity	11cc/rev
Maximum operating pressure	150kg/cm ² (2130psi)
Rated oil quantity	22 l /min (5.81U.S. gpm/4.84U.K. gpm)

4) MAIN CONTROL VALVE

Item	Specification
Type	2 spool
Operating method	Hydraulic pilot assist
Main relief valve pressure	200kg/cm ² (2840psi)
Overload relief valve pressure	230~250kg/cm ² (3270~3560psi)

5) REMOTE CONTROL VALVE

Item	Specification	
Type	Pressure reducing type	
Operating pressure	Minimum	5.8kg/cm ² (82.5psi)
	Maximum	19kg/cm ² (270psi)
Single operation stroke	Lever	70mm(2.8in)

6) CYLINDER

Item	Specification
Boom cylinder	Bore dia × Rod dia × Stroke ø 160 × ø 90 × 757mm
Bucket cylinder	Bore dia × Rod dia × Stroke ø 180 × ø 90 × 552mm
Steering cylinder	Bore dia × Rod dia × Stroke ø 80 × ø 45 × 450mm

7) DYNAMIC POWER TRANSMISSION DEVICES

Item		Specification
Torque converter	Model	ZF 02G 074 97
	Type	Single-stage, single-phase
Transmission	Type	Full-automatic power shift
	Gear shift	Forward fourth gear, reverse third gear
	Adjustment	Electrical single lever type, kick-down system
Axle	Drive devices	4-wheel drive
	Front	Front fixed location
	Rear	Oscillation 24° of center pin-loaded
Wheels	Tires	23.5-25, 20PR(L3)
Brakes	Travel	Four-wheel, wet-disc type, full hydraulic
	Parking	Spring applied, hydraulic released brake on front axle
Steering	Type	Full hydraulic, articulated
	Steering angle	40° to both right and left angle, respectively

5. TIGHTENING TORQUE OF MAJOR COMPONENT

No.	Items	Size	kgf · m	lbf · ft	
1	Engine	Engine mounting bolt, nut	M12×1.25	13.3± 2.7	96.2 ± 19.5
2		Radiator mounting bolt, nut	M12×1.75	12.3 ± 2.5	89 ± 18.1
3	Hydraulic system	Main pump housing mounting bolt	M12×1.75	12.8 ± 3	92.6 ± 21.7
4		Main control valve mounting socket bolt	M10×1.5	6.9 ± 1.4	50 ± 10
5		Obitrol valve mounting bolt	3/8-16UNC	3.3 ± 0.8	24 ± 5.8
6		Priority valve mounting bolt	M 8×1.25	2.5 ± 0.5	18 ± 3.6
7		Brake valve mounting bolt	M 8×1.25	2.5 ± 0.5	18 ± 3.6
8		Cut off valve mounting bolt	M 8×1.25	2.5 ± 0.5	18 ± 3.6
9		Cushion valve mounting bolt	M 8×1.25	2.5 ± 0.5	18 ± 3.6
10		Fuel tank mounting bolt	M20×2.5	57.9 ± 8.7	419 ± 63
11		Hydraulic oil tank mounting bolt	M20×2.5	21.9 ± 3.3	158 ± 23.9
12		Air tank mounting bolt	M20×2.5	29.7± 4.5	215 ± 33
13	Power train system	Transmission mounting bolt	M16×2.0	13.8± 1.5	99.8 ± 10.8
14		Front axle mounting bolt, nut	M24×2.0	100 ± 15	723 ± 108
15		Rear axle support mounting bolt, nut	M33×2.0	215	1555
16		Tire mounting nut	M20×1.5	61 ± 2	441 ± 15
17		Drive shaft joint mounting bolt, nut	1/2-20UNF	12.2 ± 1.3	88.2± 9.4
18	Others	Counterweight mounting bolt	M30×3.0	199 ± 29.9	1439 ± 216
19		Operator's seat mounting bolt	M 8×1.25	2.5± 0.5	18.1± 3.6
20		ROPS Cab mounting bolt(12EA)	1-14UNS	86	620
		ROPS Cab mounting bolt(4EA)	1 1/4-12UNF	126	911

6. TORQUE CHART

Use following table for unspecified torque.

1) BOLT AND NUT

(1) Coarse thread

Bolt size	8T		10T	
	kgf · m	lbf · ft	kgf · m	lbf · ft
M 6 × 1.0	0.85 ~ 1.25	6.15 ~ 9.04	1.14 ~ 1.74	8.2 ~ 12.6
M 8 × 1.25	2.0 ~ 3.0	14.5 ~ 21.7	2.73 ~ 4.12	19.7 ~ 29.8
M10 × 1.5	4.0 ~ 6.0	28.9 ~ 43.4	5.5 ~ 8.3	39.8 ~ 60
M12 × 1.75	7.4 ~ 11.2	53.5 ~ 79.5	9.8 ~ 15.8	71 ~ 114
M14 × 2.0	12.2 ~ 16.6	88.2 ~ 120	16.7 ~ 22.5	121 ~ 167
M16 × 2.0	18.6 ~ 25.2	135 ~ 182	25.2 ~ 34.2	182 ~ 247
M18 × 2.5	25.8 ~ 35.0	187 ~ 253	35.1 ~ 47.5	254 ~ 343
M20 × 2.5	36.2 ~ 49.0	262 ~ 354	49.2 ~ 66.6	356 ~ 482
M22 × 2.5	48.3 ~ 63.3	350 ~ 457	65.8 ~ 98.0	476 ~ 709
M24 × 3.0	62.5 ~ 84.5	452 ~ 611	85.0 ~ 115	615 ~ 832
M30 × 3.5	124 ~ 168	898 ~ 1214	169 ~ 229	1223 ~ 1655
M36 × 4.0	174 ~ 236	1261 ~ 1703	250 ~ 310	1808 ~ 2242

(2) Fine thread

Bolt size	8T		10T	
	kgf · m	lbf · ft	kgf · m	lbf · ft
M 8 × 1.0	2.17 ~ 3.37	15.7 ~ 24.3	3.04 ~ 4.44	22.0 ~ 32.0
M10 × 1.25	4.46 ~ 6.66	32.3 ~ 48.2	5.93 ~ 8.93	42.9 ~ 64.6
M12 × 1.25	7.78 ~ 11.58	76.3 ~ 83.7	10.6 ~ 16.0	76.6 ~ 115
M14 × 1.5	13.3 ~ 18.1	96.2 ~ 130	17.9 ~ 24.1	130 ~ 174
M16 × 1.5	19.9 ~ 26.9	144 ~ 194	26.6 ~ 36.0	193 ~ 260
M18 × 1.5	28.6 ~ 43.6	207 ~ 315	38.4 ~ 52.0	278 ~ 376
M20 × 1.5	40.0 ~ 54.0	289 ~ 390	53.4 ~ 72.2	386 ~ 522
M22 × 1.5	52.7 ~ 71.3	381 ~ 515	70.7 ~ 95.7	512 ~ 692
M24 × 2.0	67.9 ~ 91.9	491 ~ 664	90.9 ~ 123	658 ~ 890
M30 × 2.0	137 ~ 185	990 ~ 1338	182 ~ 248	1314 ~ 1795
M36 × 3.0	192 ~ 260	1389 ~ 1879	262 ~ 354	1893 ~ 2561

2) PIPE AND HOSE

Thread size	Width across flat(mm)	kgf · m	lbf · ft
1/4"	19	3	21.7
3/8"	22	4	28.9
1/2"	27	5	36.2
3/4"	36	12	86.8
1"	41	14	101

3) FITTING

Thread size	Width across flat(mm)	kgf · m	lbf · ft
1/4"	19	4	28.9
3/8"	22	5	36.2
1/2"	27	6	43.4
3/4"	36	13	94.0
1"	41	15	109

7. RECOMMENDED LUBRICANTS

Use only oils listed below or equivalent.
Do not mix different brand oil.

Service point	Kind of fluid	Capacity l (U.S. gal)	Ambient temperature °C (°F)								
			-20 (-4)	-10 (14)	0 (32)	10 (50)	20 (68)	30 (86)	40 (104)		
Engine oil pan	Engine oil	22.4(5.9)					SAE 30				
			SAE 10W								
			SAE 10W-30								
			SAE 15W-40								
Torque converter Transmission	Oil	28(7.4)	SAE 10W-30								
Axle	Oil	Front : 62(16.4) Rear : 42(11.1)	SAE 80W-90LSD/APIGL-5								
Hydraulic tank	Hydraulic oil	Tank: 199(52.6) System: 294(77.7)	ISO VG 32								
			ISO VG 46								
			ISO VG 68								
Fuel tank	Diesel fuel	289(76.4)	ASTM D975 NO. 1								
			ASTM D975 NO. 2								
Fitting (Grease nipple)	Grease	As required	NLGI NO. 1								
			NLGI NO. 2								
Radiator	Mixture of antifreeze and water 50 : 50	40(10.6)	Ethylene glycol base permanent type								