

## GROUP 4 DISASSEMBLY AND ASSEMBLY

### 1. MAIN PUMP

#### 1) STRUCTURE

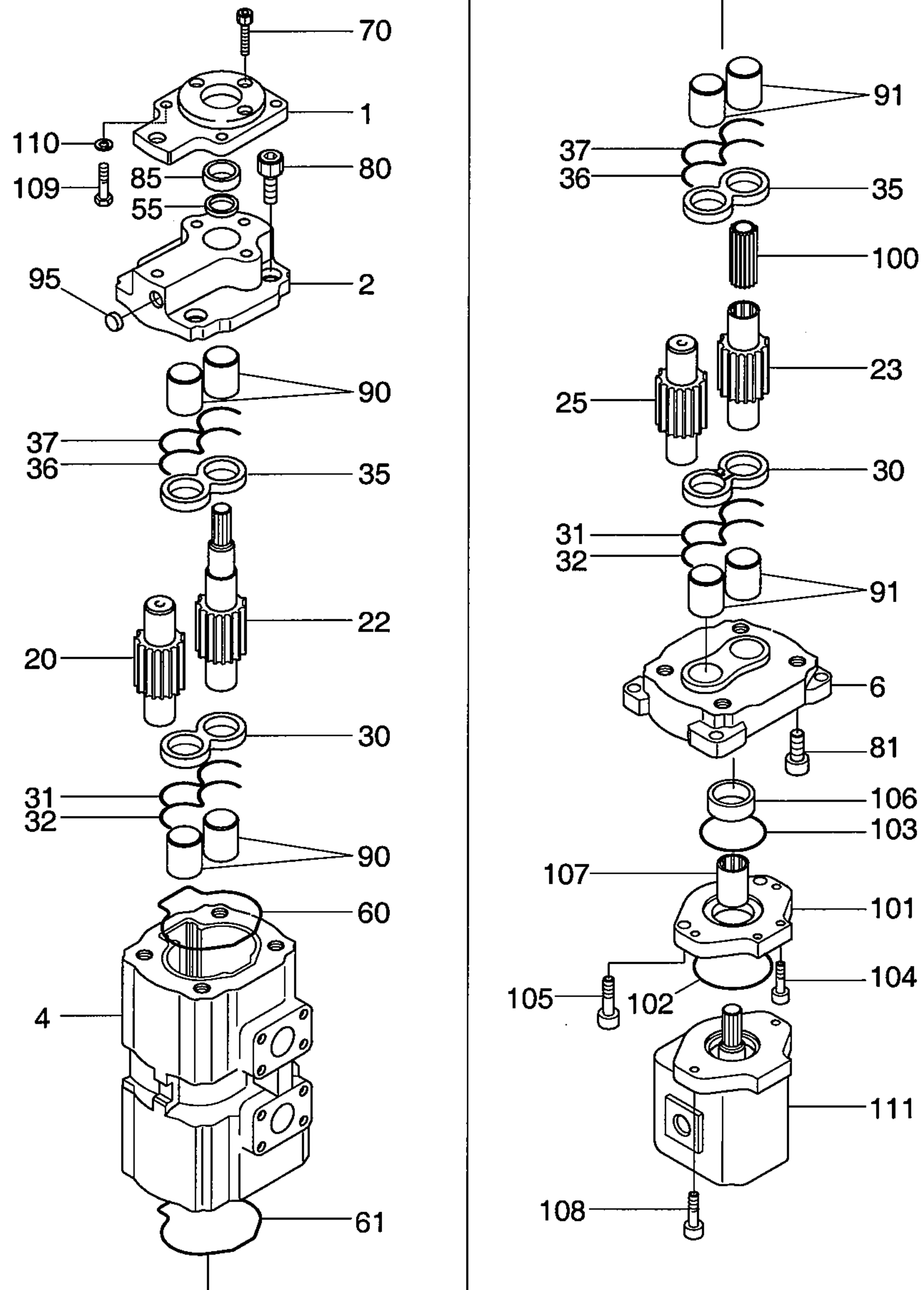

1	Flange	36	Moulded seal	100	Splined coupling
2	Front cover	37	Back up seal	101	Rear adaptor
4	Dual body	55	Viton shaft seal	102	O-ring seal
6	Rear cover	60	O-ring	103	Viton O-ring
20	Driven gear	61	O-ring	104	Cap screw
22	Front drive gear	70	Cap screw	105	Cap screw
23	Drive gear	80	Socket screw	106	Location ring
25	Driven gear	81	Socket screw	107	Coupling
30	Wear plate	85	Location ring	108	Cap screw
31	Moulded seal	90	Plain bearing	109	Hexagon head screw
32	Back up seal	91	Plain bearing	110	Washer
35	Wear plate	95	Seal	111	Brake pump

## 2) GENERAL INSTRUCTION

### (1) Cleanliness

① Cleanliness is the primary means of assuring satisfactory hydraulic pump life. Components such as flanges and covers are best cleaned in soap and hot water, then air dried. Gears should be washed in solvent, air dried, and oiled immediately.

**▲ Certain cleaning solvents are flammable. Do not allow sources of ignition in the area when using cleaning solvents.**

② Protect all exposed surfaces and open cavities from damage and foreign material.

**\* Gear journals and gear faces are super finished. Take care not to touch these surfaces after oil and solvent have been removed.**

### (2) Lubrication of moving parts

During assembly, all running surfaces(Bearing and wear plate) must be lightly lubricated with a clean oil or aerosol lubricant.

### (3) Tools required for assembly

- ① Torque wrench(0~50kgf · m, 0~360lbf · ft)
- ② Open end wrenches
- ③ Seal installation tools(Inner and outer)
- ④ Shaft bullet(Seal protector)
- ⑤ Installation plate

### (4) Tightening torque

Item	Torque	
	kgf · m	lbf · ft
Screw(70)	9	65
Screw(80)	40	290

### 3) DISASSEMBLY

※ Plug all ports prior to cleaning and disassembling pump to prevent ingress of debris or contamination.

Clean the pump thoroughly with a solvent, ensuring no loose debris or contamination remains on the unit.

Dry pump using compressed air or clean lint-free cloths.

(1) Remove the cap screw(70).

Remove the mounting flange(1). Under no circumstances attempt to prise mounting flange from cover as such action could damage the machine interface. If necessary use of a soft faced mallet to remove mounting flange is recommended.

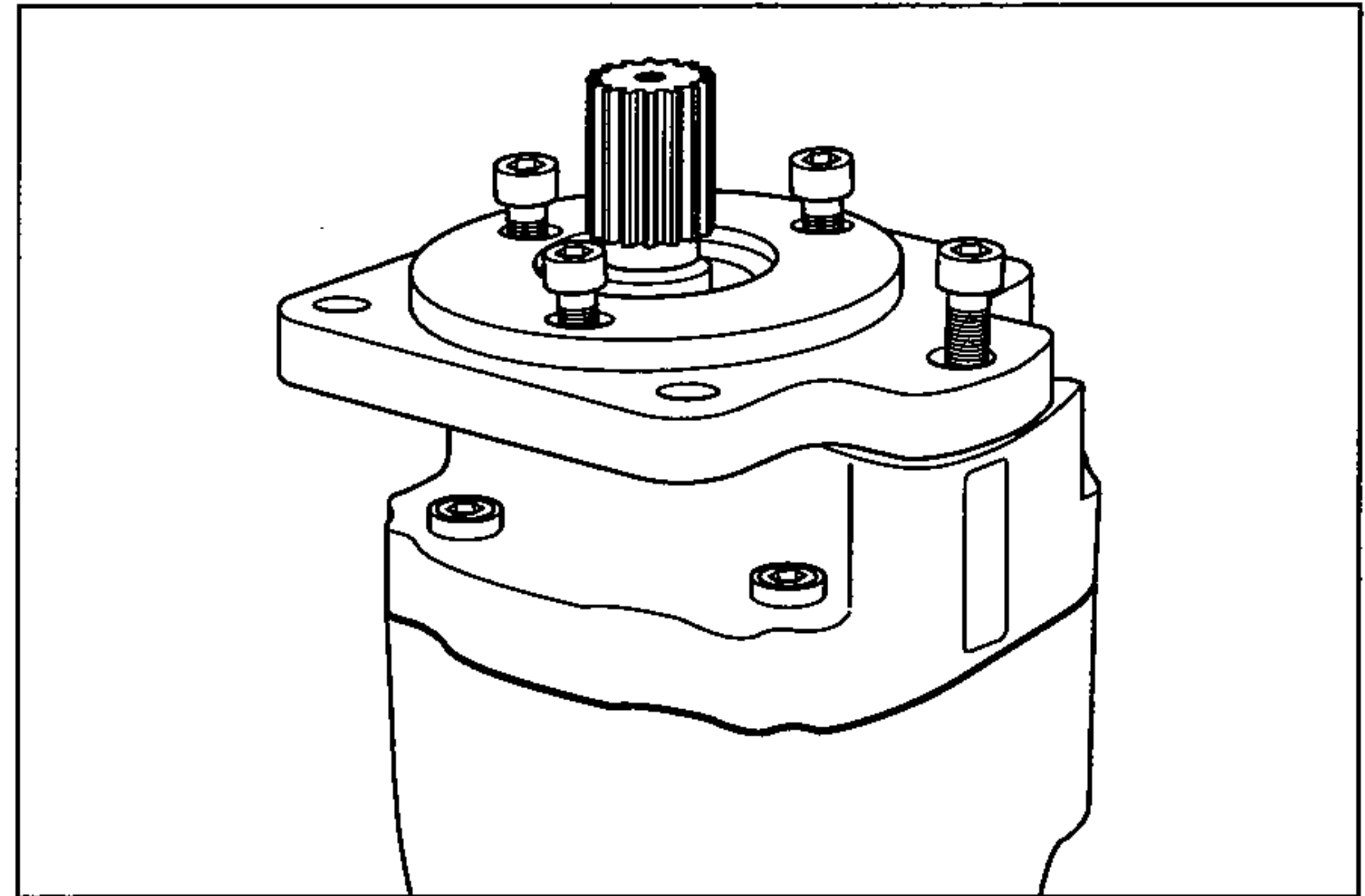

(2) Remove the cap screws(80) securing the cover(2) to body(4).

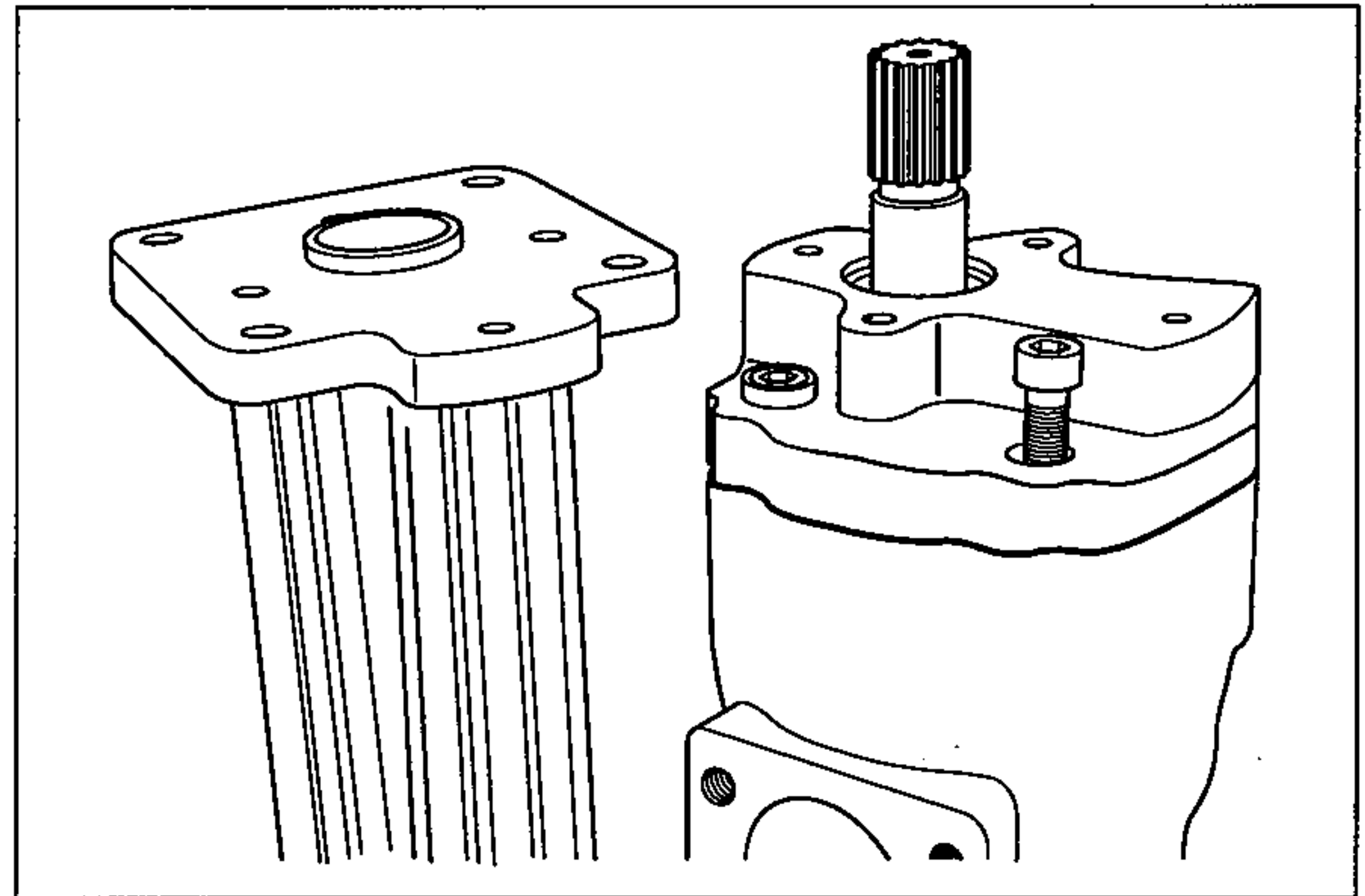

(3) Refit the mounting flange(1) to cover(2) with two cap screws(70) and detach the cover(2) complete with the mounting flange from the body(4) using a pulling tool centred on the drive shaft.

※ Under NO circumstances attempt to prise or chisel cover from body as such action could damage the machined sealing faces.

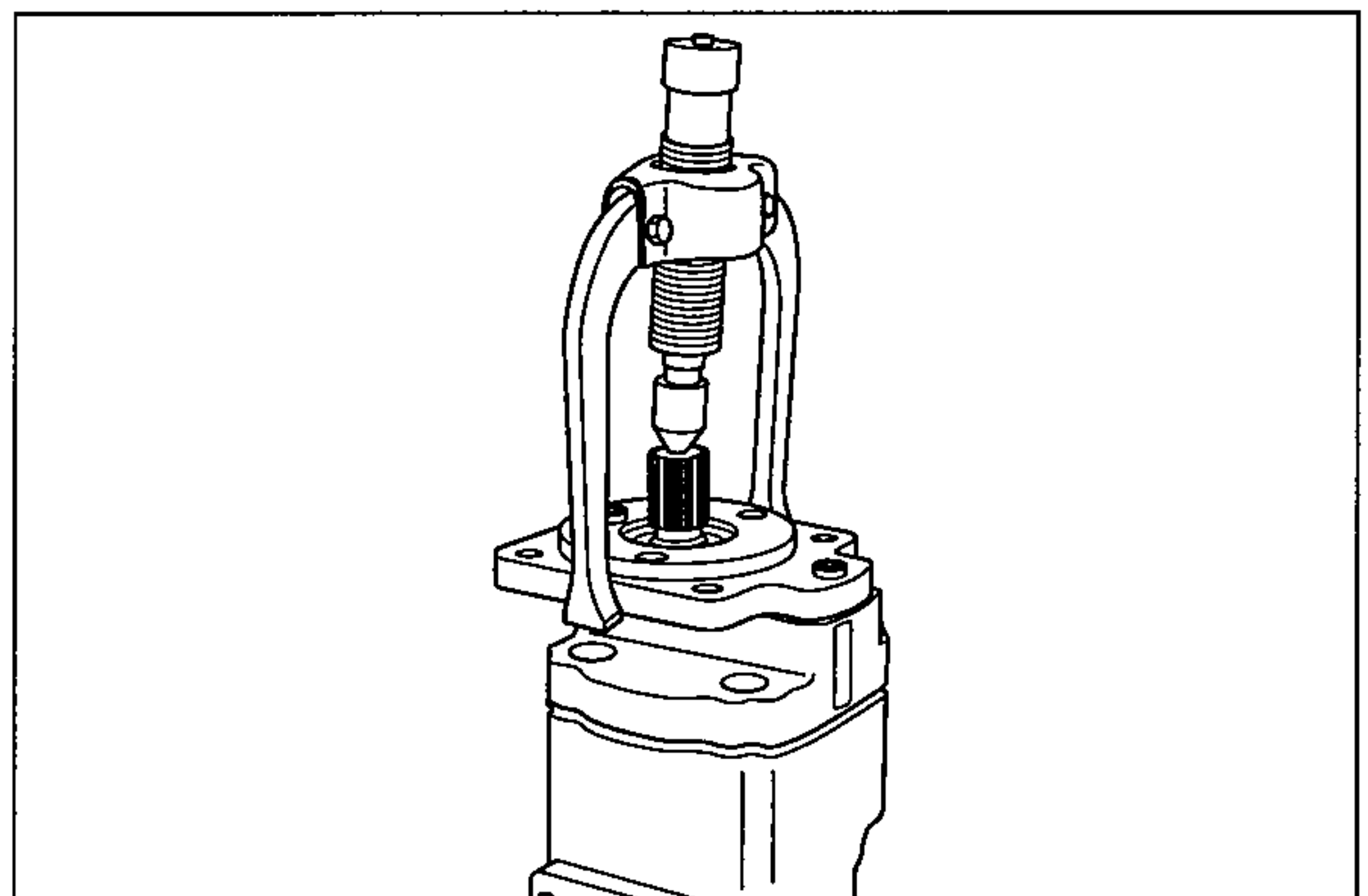



Remove the shaft seal(55) from cover(2) making sure that no damage is sustained to the surface of the seal bore in the cover.

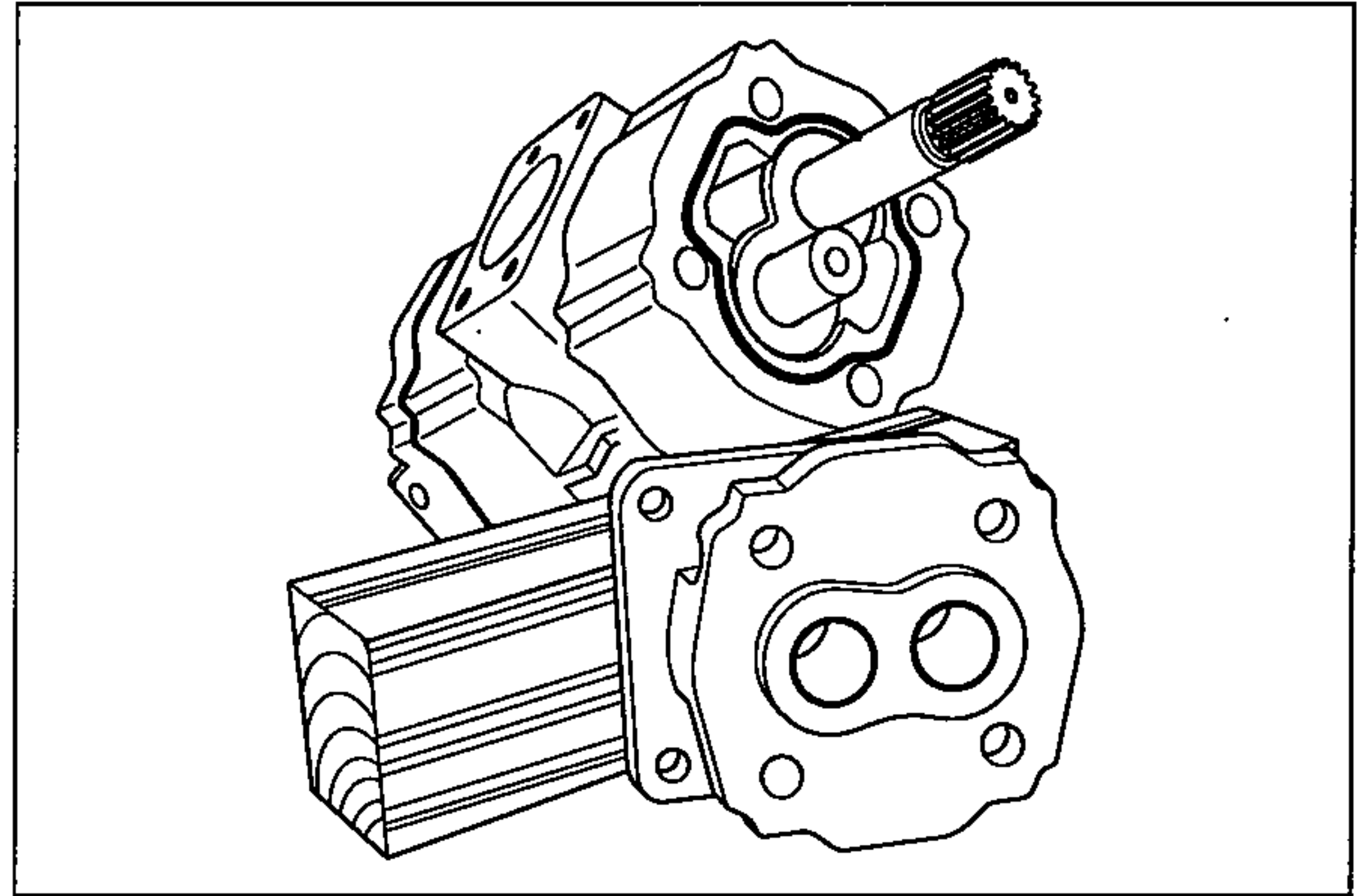

- (4) Before removing wear plate(35) from the body(4) mark it using a soft pencil or a felt-tip pen to ensure correct reassembly. Remove wear plate(35) complete with wear plate seal and back up seal.

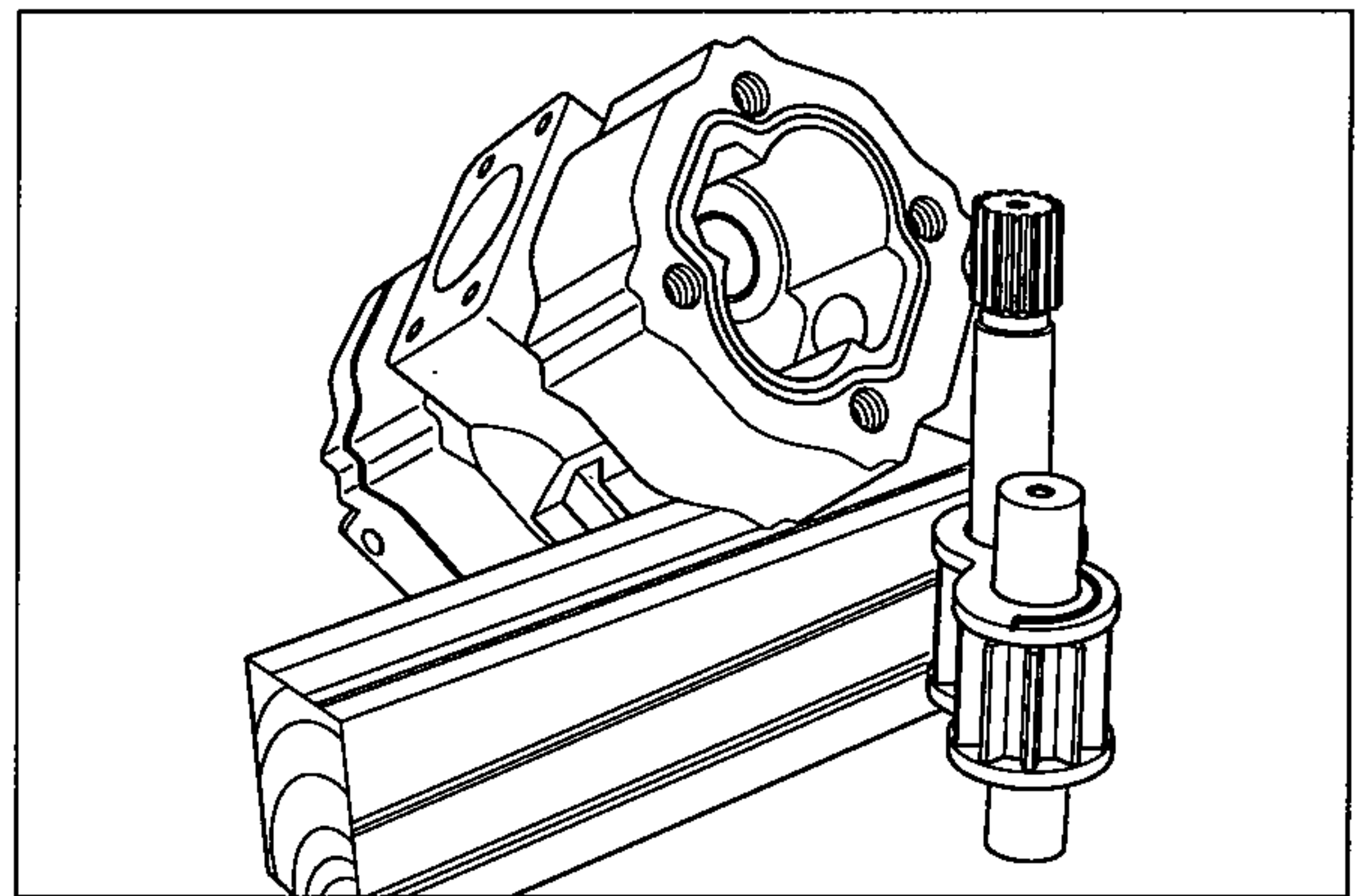

- ※ Mark the gears using a soft pencil or felt-tip pen to ensure reassembly in the same relative position, then withdraw the drive shaft/gear and driven gear separately to prevent jamming. Again, to ensure correct reassembly, mark remaining wear plate(30) using a soft pencil a felt-tip pen. Remove wear plate(35) from body(4) complete with wear plate seal and back up seal.

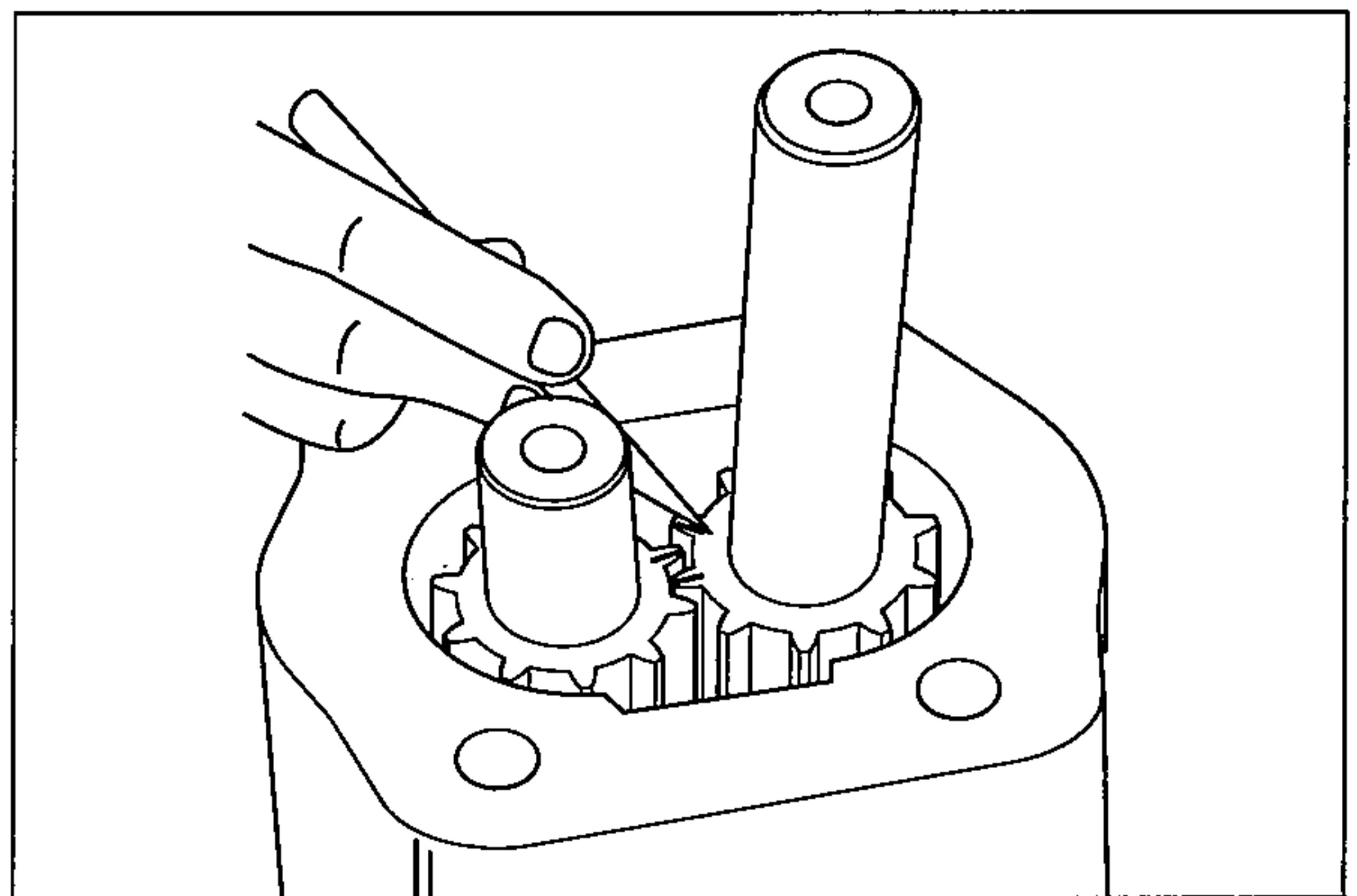

- (5) Remove the cap screws(81) and remove rear cover(5).  
※ Before removing wear plate(30) from the body(4) mark it using a soft pencil or a felt-tip pen to ensure correct reassembly.

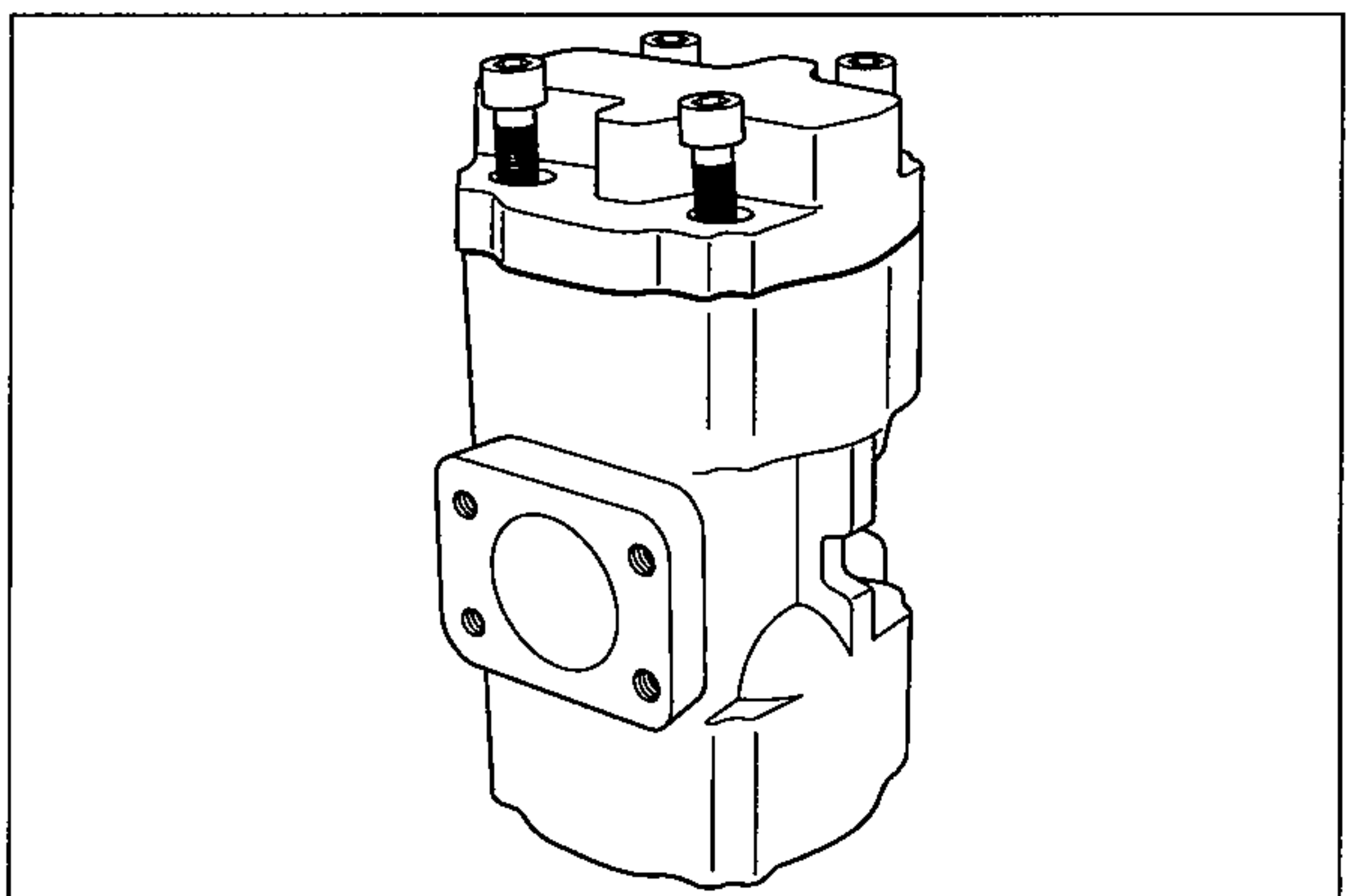

(6) Remove wear plate complete with wear plate seal and back up seal. Mark the gears using a soft pencil or felt-up pen to ensure reassembly in the same relative position. Then withdraw the drive shaft/gear and driven gear separately to prevent jamming.

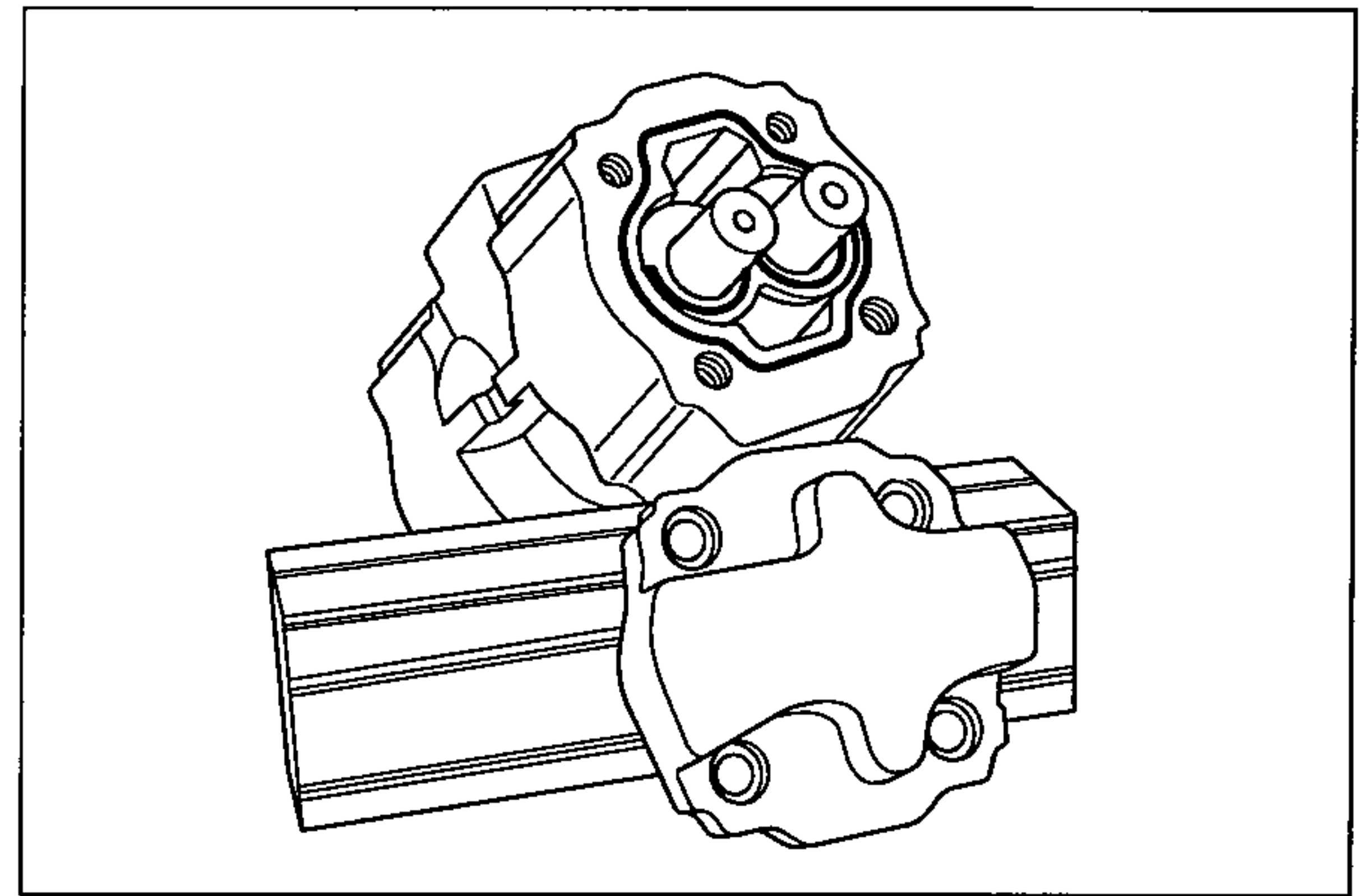

Again to ensure correct reassembly mark remaining wear plate(35) using a soft pencil or a felt-tip pen. Remove wear plate(35) from body(4) complete with wear plate seal and back up seal.

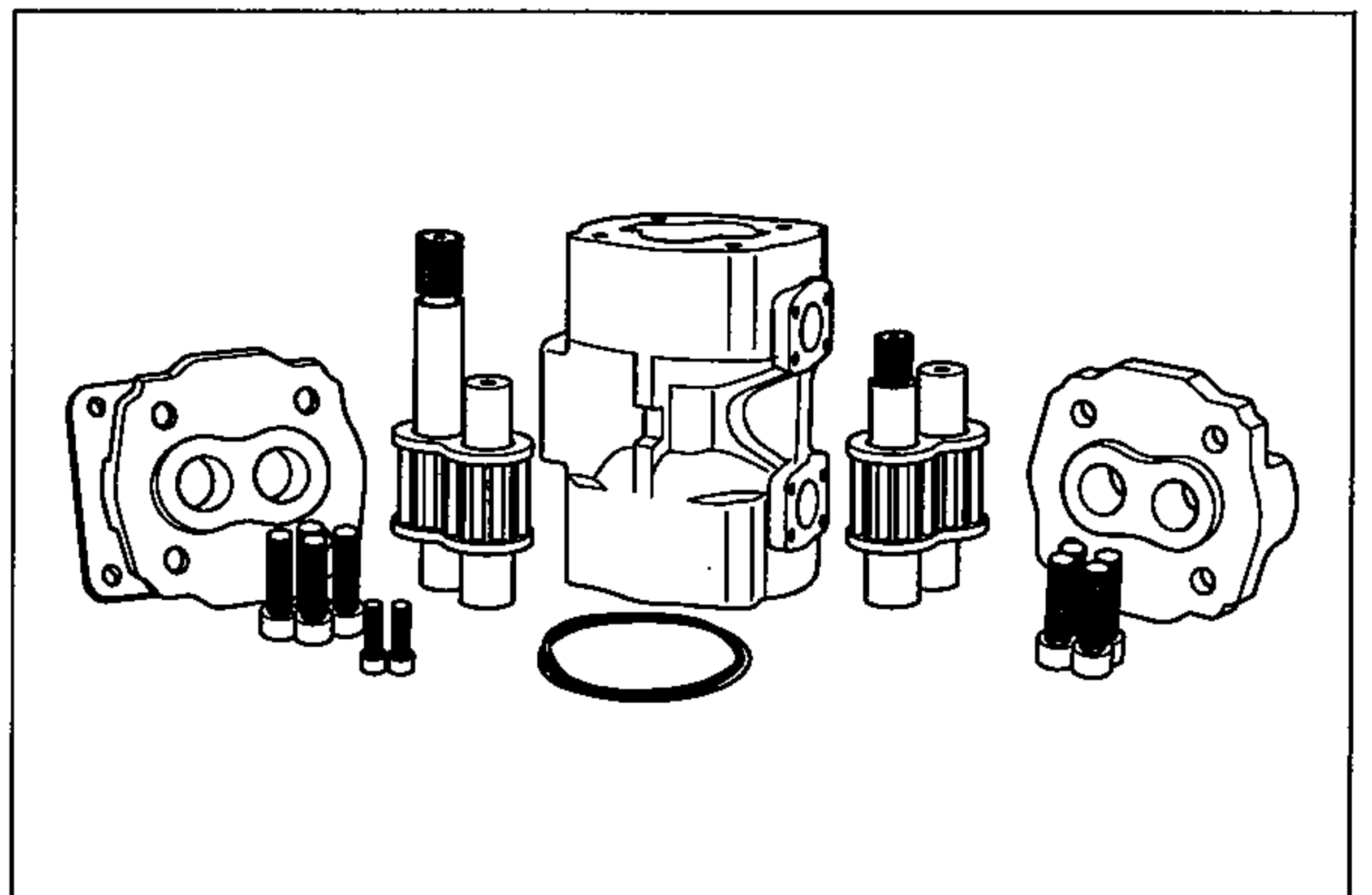
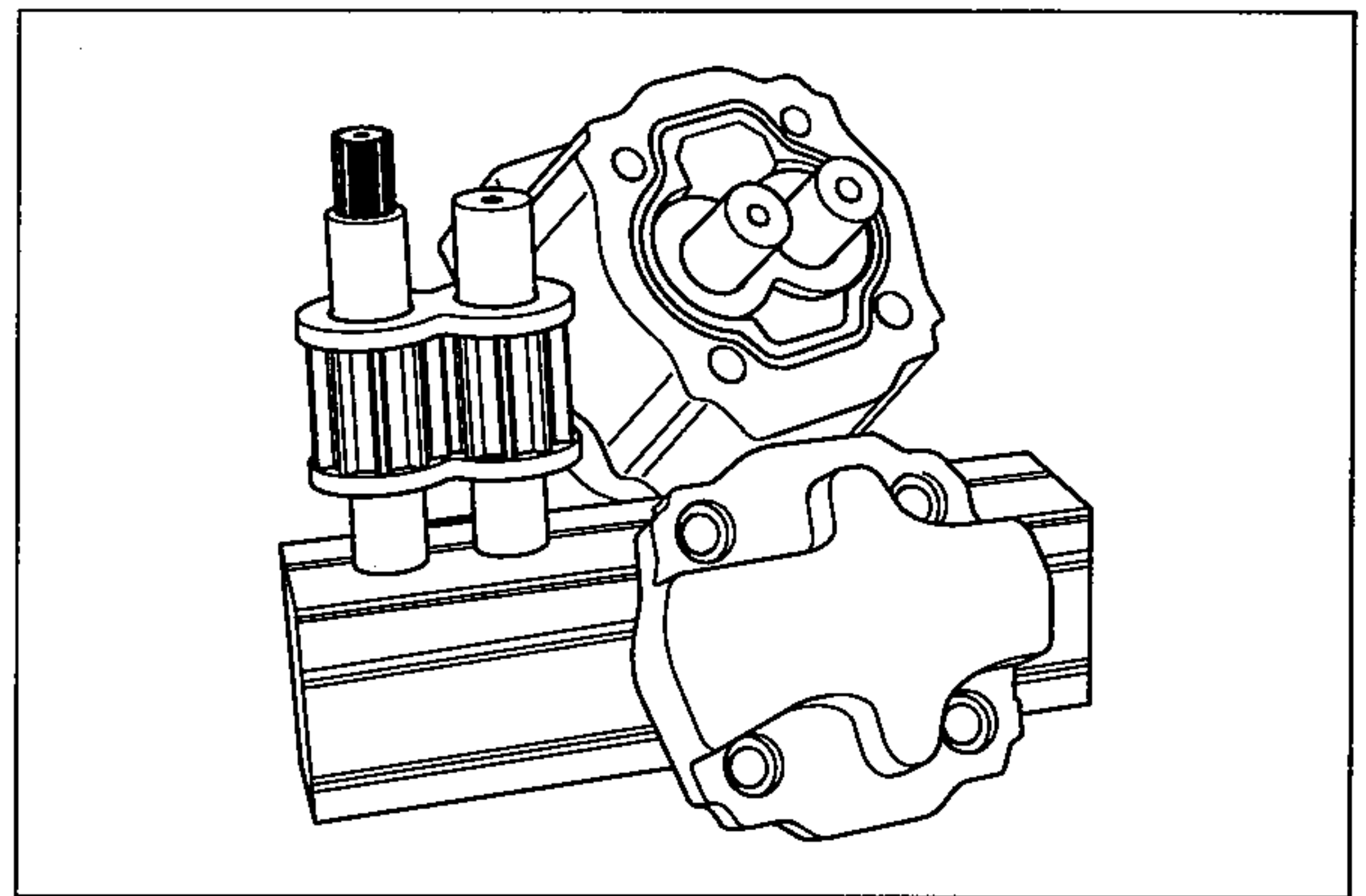

#### 4) MANDATORY REPLACEMENT PARTS

Discard all seals including interface seals, shaft seals, wear plate seals and back up seals. Fit new seals on reassembly.

#### 5) HANDLING/STORAGE

While disassembling pump, ensure no surfaces are scored or marked in any way. A rubber surfaced table will be beneficial. All components must be placed in a clean, dry and safe area. Leakage will be created by scratches on components. If parts are to be left for any period ensure they are not exposed to dirt, dust and corrosion. Keep gears separate from each other in cardboard boxes.

#### 6) INSPECTION OF PARTS

Wash all parts in a solvent and dry using compressed air or clean, lint-free cloths.

##### (1) Mounting flange, housing and cover

The pump must be replaced if the damage listed is present.

Feature	Damage
Surfaces	Corrosion, nicks or burrs(slight burrs can be removed using and india stone)
Machined sealing Interfaces	Scores or cracks
Bearing bores	Incorrect diameter, grooves or distorted
Bearing	Loose

##### (2) Gears

The pump must be replaced if the damage listed is present.

Feature	Damage
Surfaces	Corrosion, nicks or burrs(slight burrs can be removed using an India stone). Wear due to seal(s)
Journals	Pitting, wear, sufficient wear to change outside diameter
Gears	Cracks or heavy scoring or chipped
Splines/keyways	Distortion of wear



**(3) Floating wear plates**

The pump must be replaced if the damage listed is present.

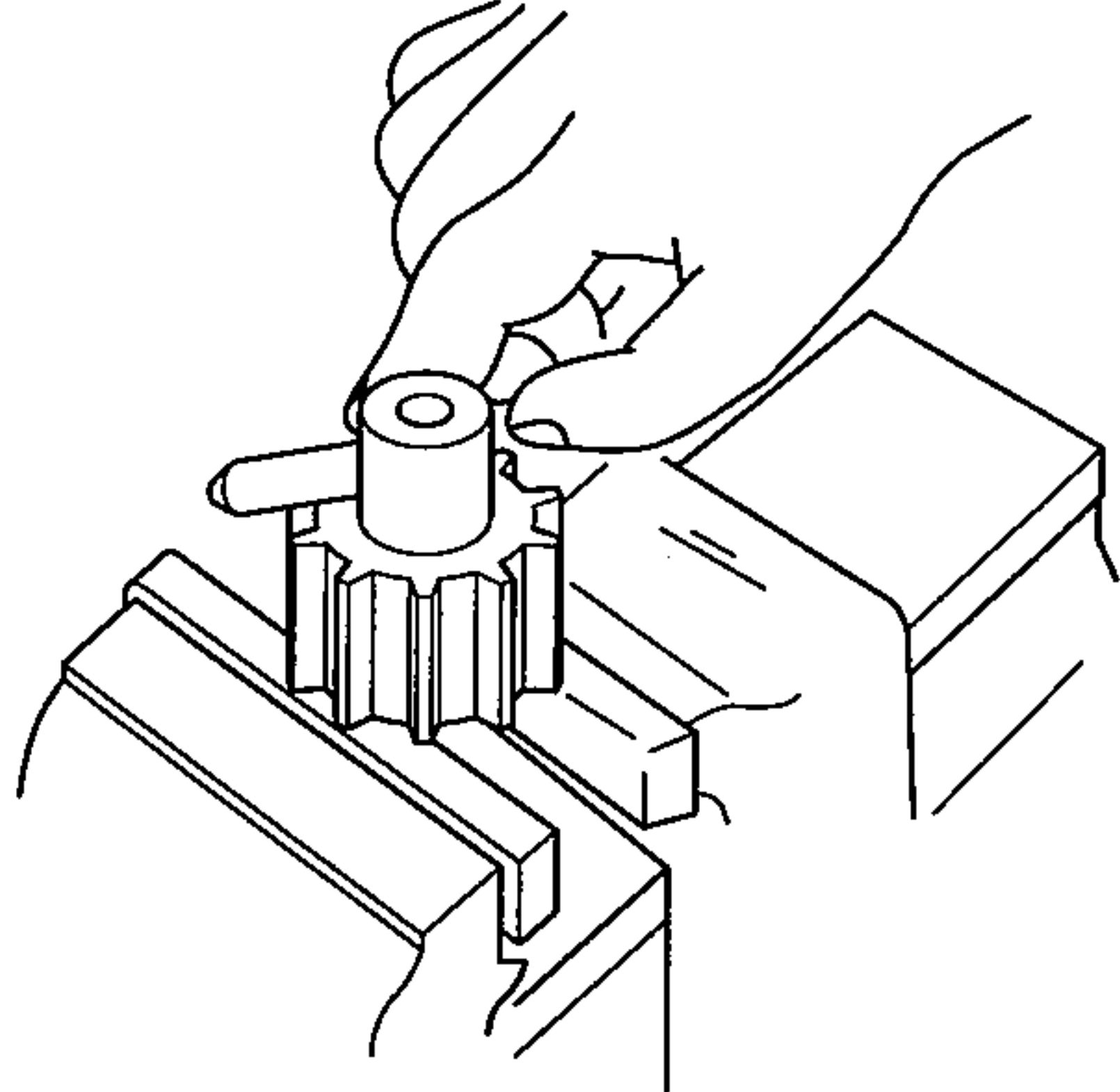
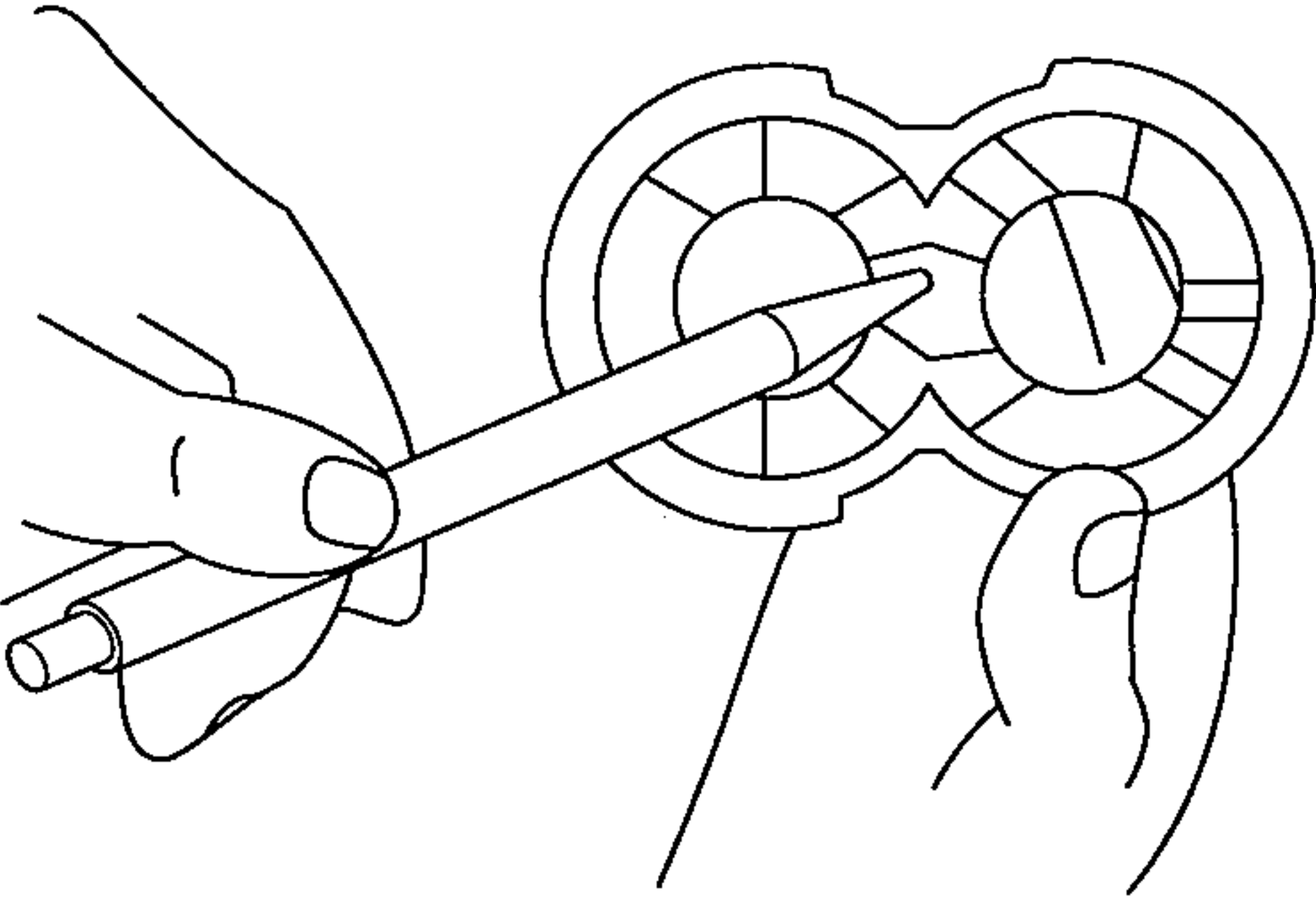
Feature	Damage
Surfaces	Corrosion, nicks or burrs, amounts of scoring, erosion or any cracks, discoloration caused by overheating
 <p data-bbox="405 1071 940 1154">Removing burrs or minor scoring from end faces and teeth of the gears.</p>	 <p data-bbox="1272 1071 1577 1115">Scoring of wear plate.</p>

**(4) Bolts/Studs**

These must be replaced if the damage listed is present.

Feature	Damage
Surfaces	Corrosion, nicks or burrs (slight burrs can be removed using an India stone), cracks or scoring, distortion or damage to thread form

**(5) Plain bearings**

The pump must be replaced if the damage listed is present.

Feature	Damage
Surfaces	Cracks or scoring
PTEF Coating	Worn
Bearing	Loosen in mating component

**(6) Coupling**

This must be replaced if damage listed is present.

Feature	Damage
Surfaces	Corrosion, nicks or burrs, erosion, cracks or pitting
Splines	Distorted or badly worn

## **7) WEAR PLATES, SEALS AND BACK UP SEAL, SUB-ASSEMBLY**

Refer to illustration on assembly drawing for the correct fitment of the wear plate seal and back up seal in the groove of the wear plates(30, 35).

It is critical that the wear plates are assembled into the pump with regard to the following :

- (1) The seal side of the wear plate must be adjacent to the cover(2) or body(4).
- (2) The high pressure side of the wear plate must be adjacent to the outlet port. Refer to assembly drawing.



## 8) ASSEMBLY

(1) Lightly oil surfaces with clean hydraulic oil.

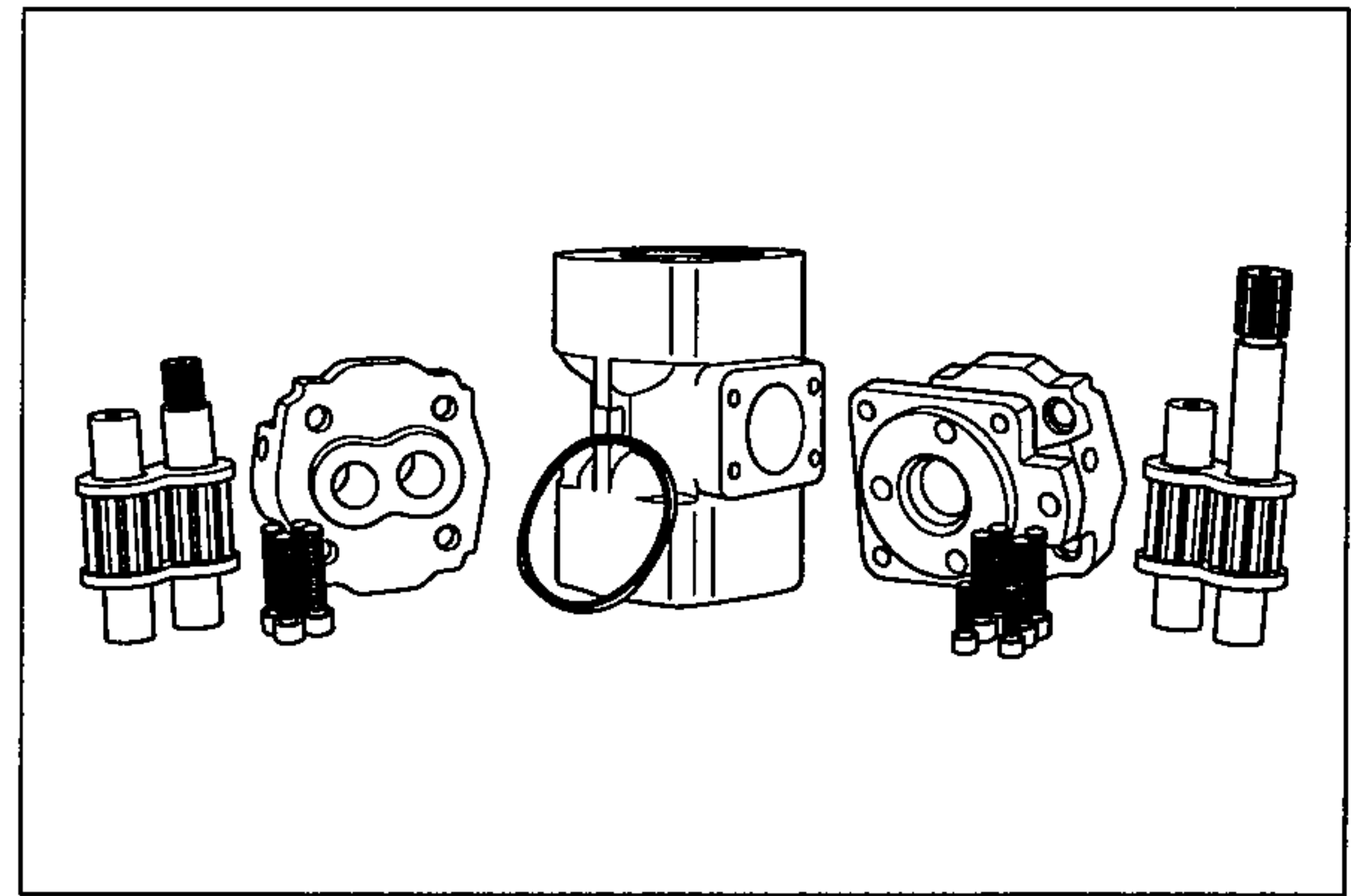

(2) Place body(4) vertically with front section gear pockets upper most.

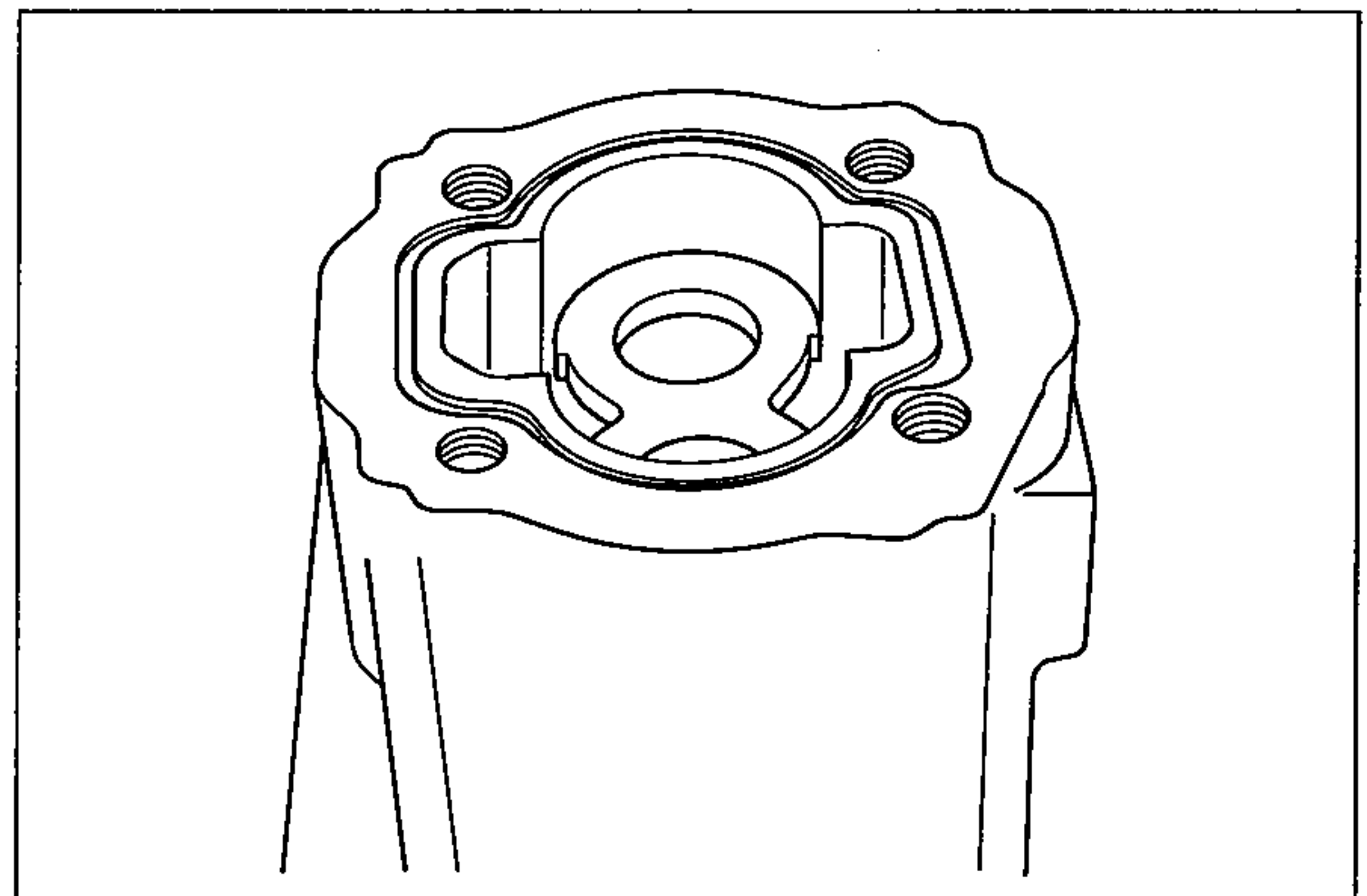

Side wear plate(30) complete with seal and back up seal down through the housing to the bottom of the gear pockets.

※ Be sure to refit the wear plate you have marked from this position.

Fit the gears within the housing taking care to replace as marked, with the teeth reassembled to their original related position.

Fit the wear plate(35) complete with seal and back up seal.

※ Be sure to refit the wear plate you have marked from this position.

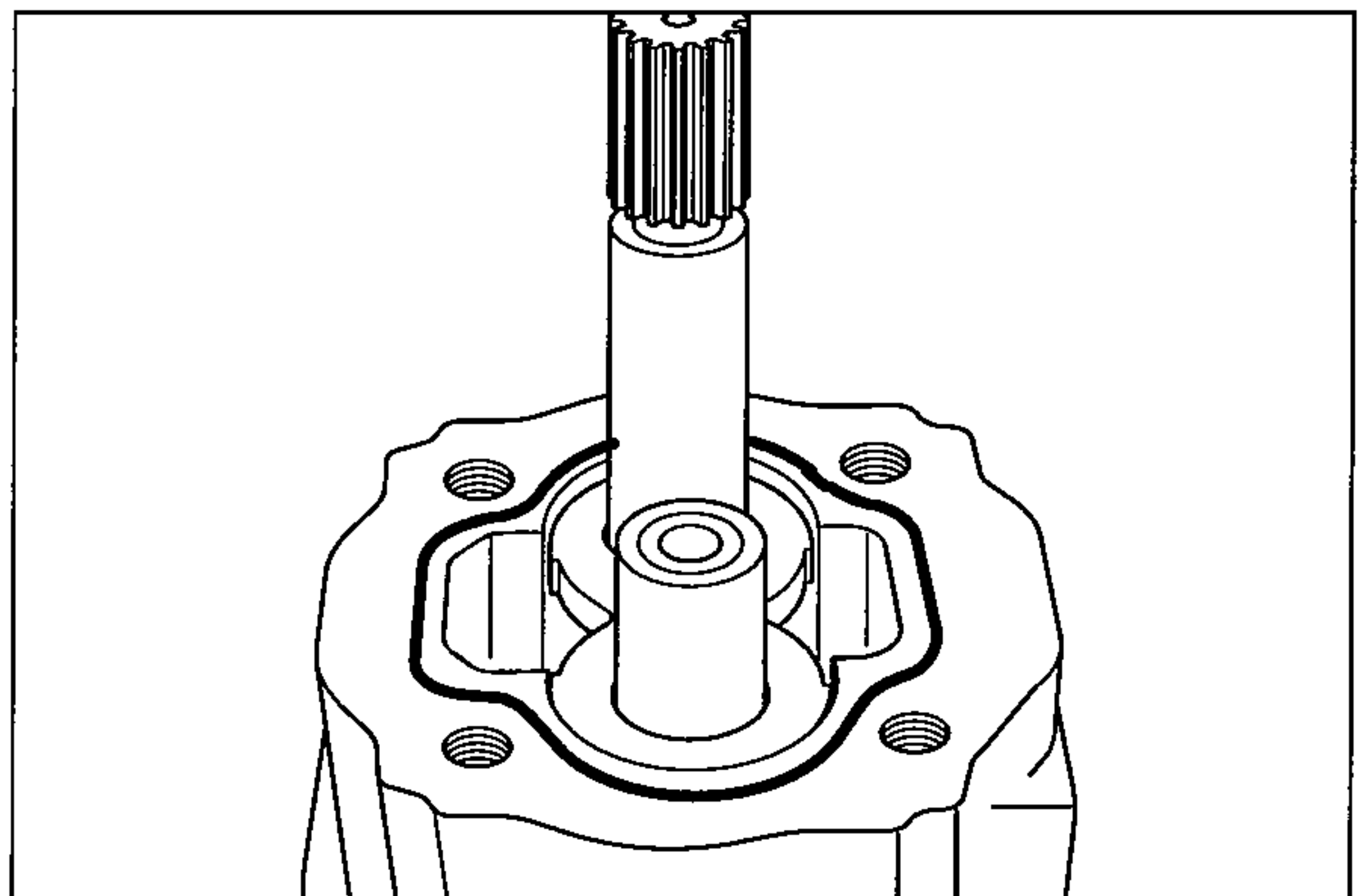

(3) Fit new interface seal(60) into groove in body(4).

Fit front cover(2) over the drive gear and secure with cap screws(70).

Tighten cap screws(80) to half torque and then full torque in diagonal sequence to figure as per assembly drawing.

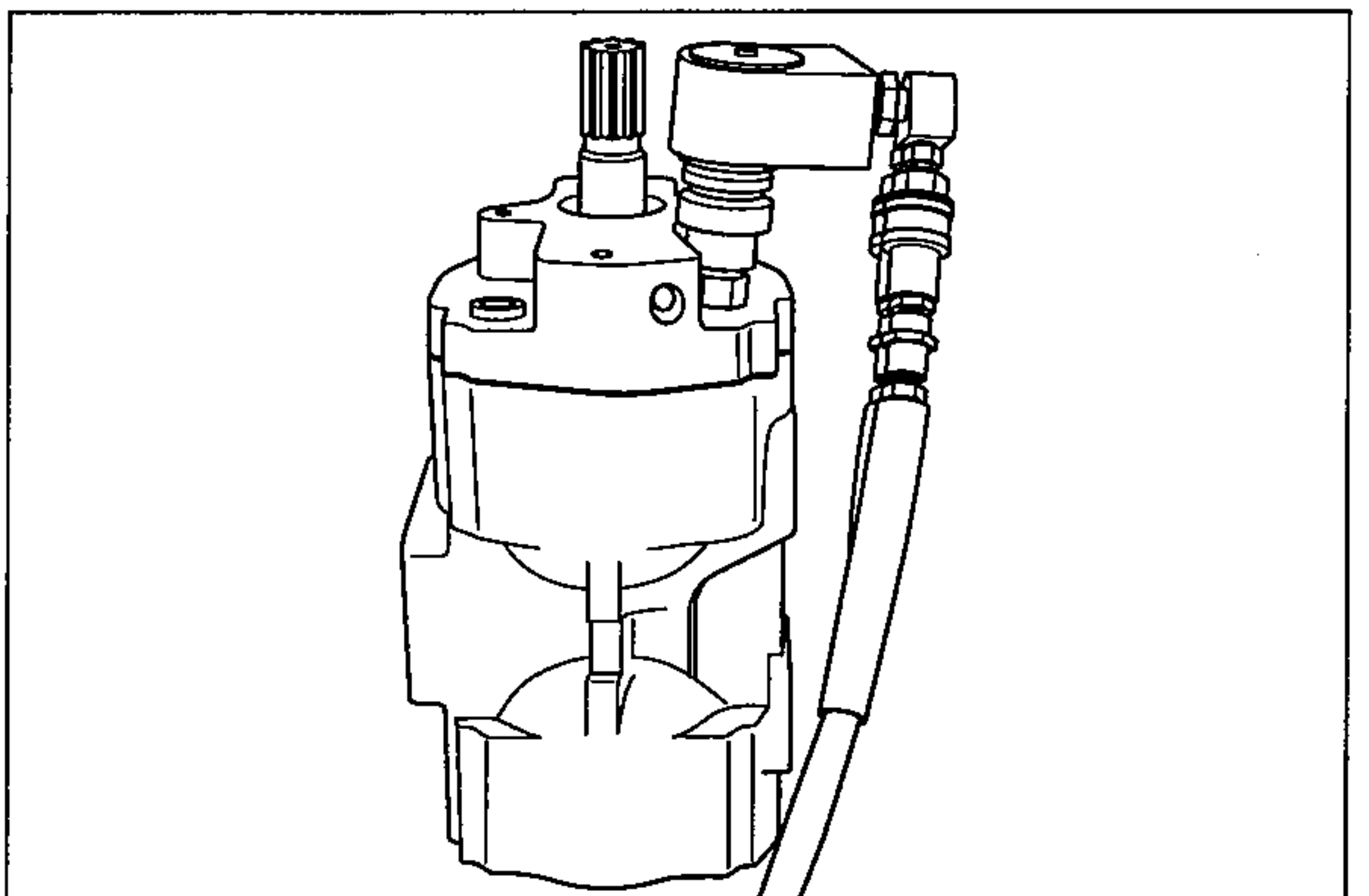

- (4) Fit shaft seal(55) using appropriate tooling as per assembly drawing, in correct position and direction.
- ※ Molybdenum disulphide grease should be sparingly applied to the lip of the shaft seal.

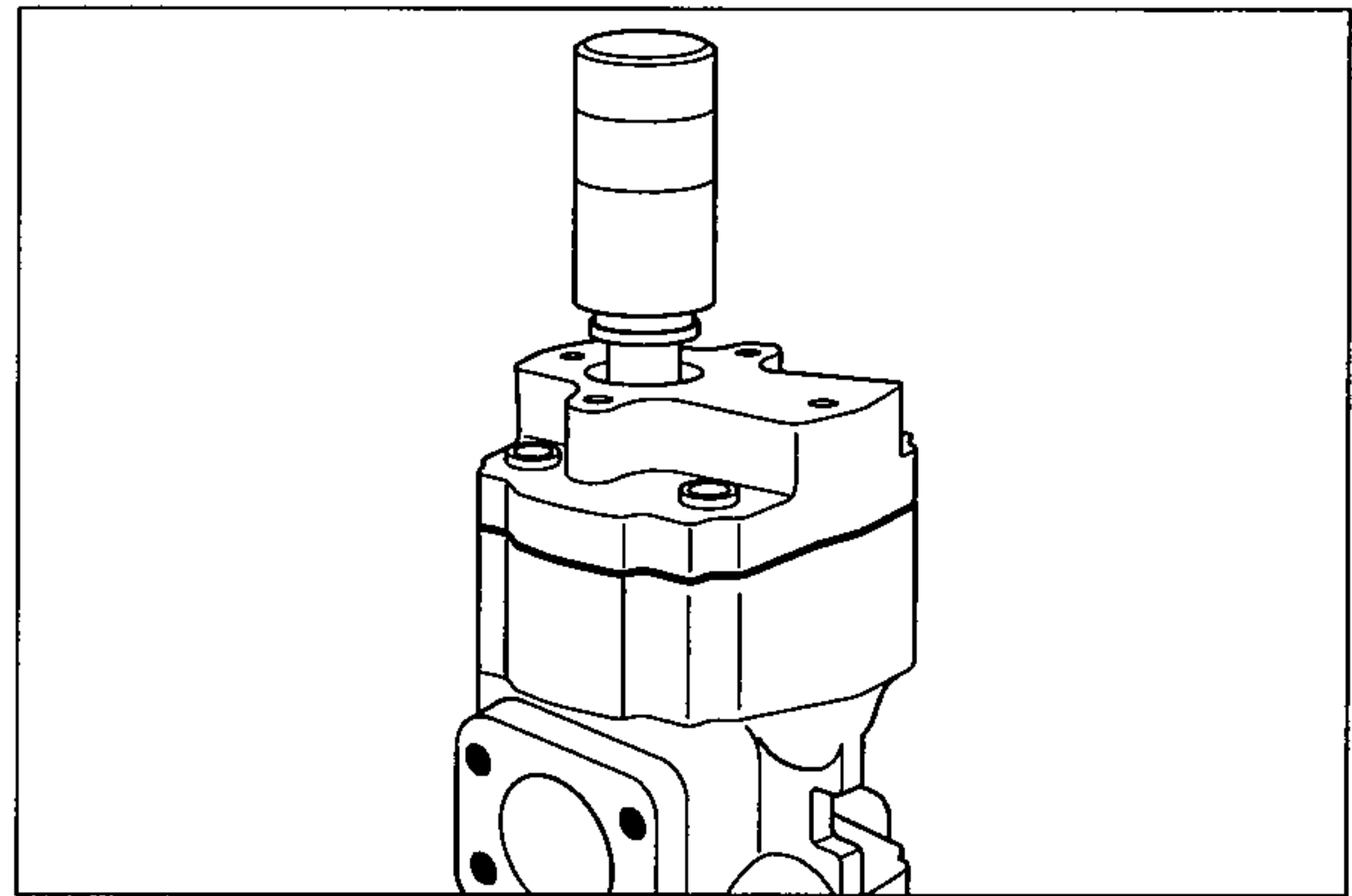

- (5) Apply a small ring of loctite low strength gasket eliminator to the interface of mounting flange(1) and fit to front cover(2), ensure that location sleeve(85) is in place and correctly positioned.

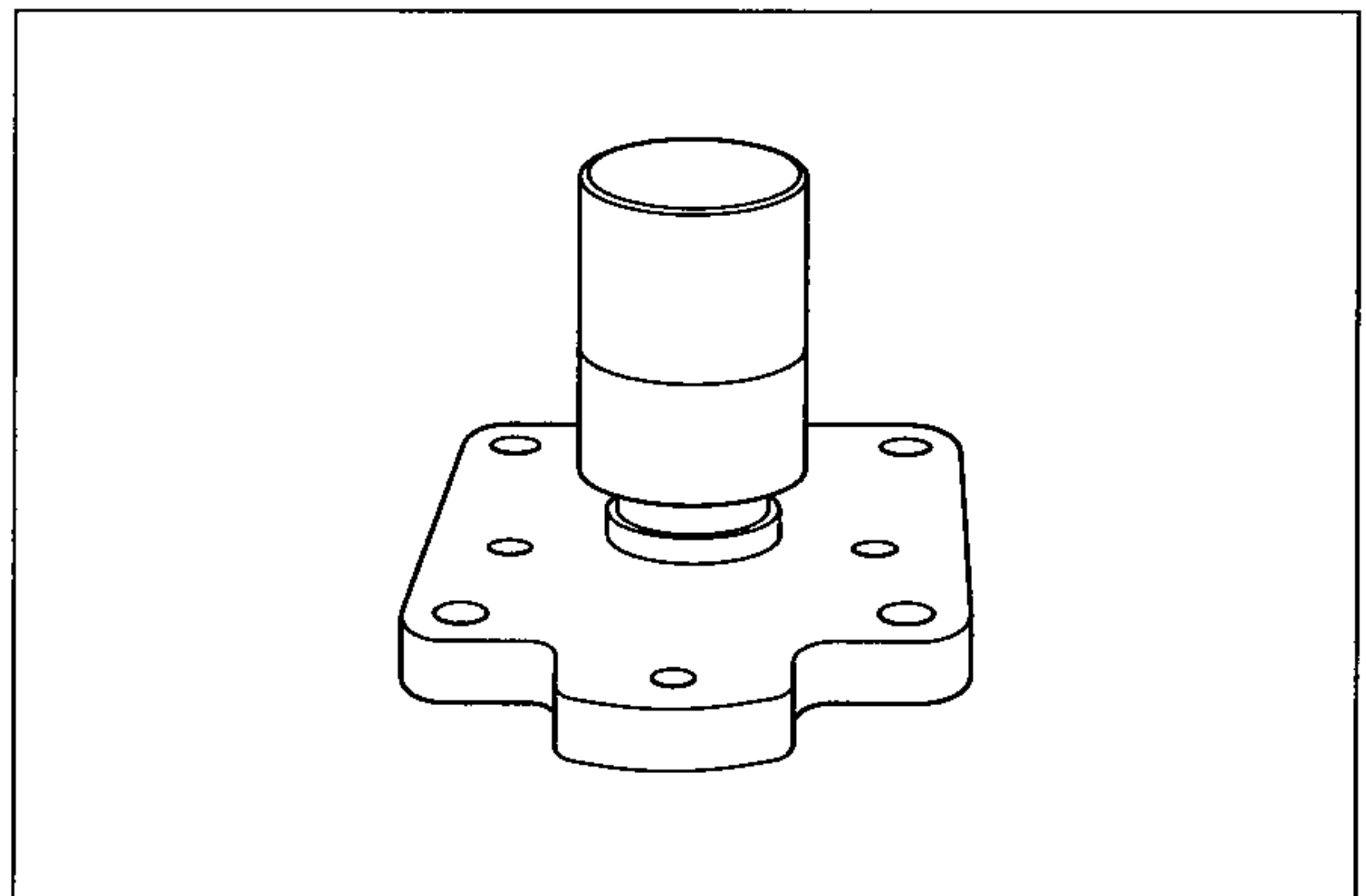

- (6) Secure mounting flange(1) with cap screws(70) and tighten to half torque and then full torque in a diagonal sequence to figure as per assembly drawing.

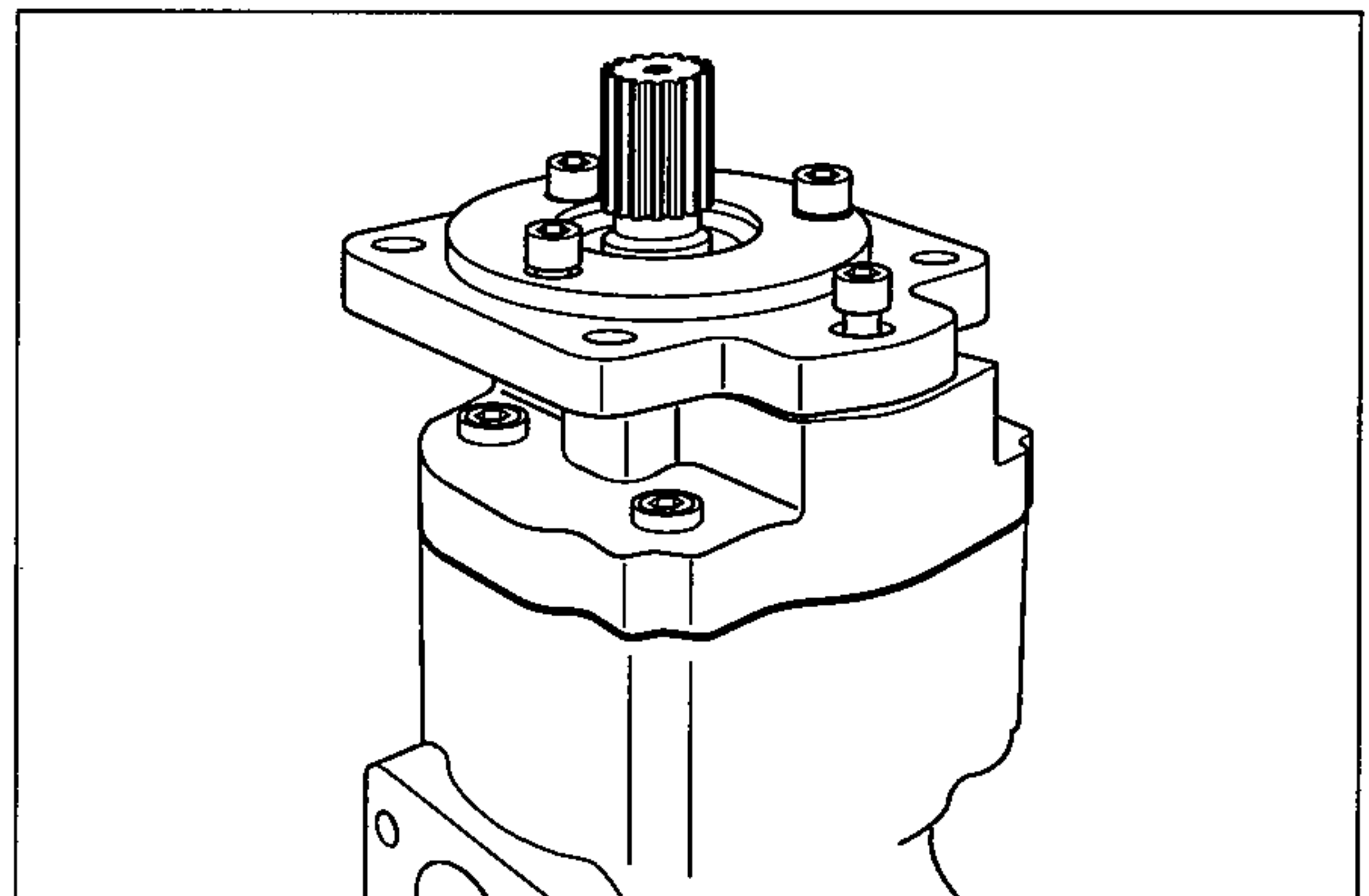

- (7) Place body(4) vertically with the rear section gear pockets upper most. Fit splined coupling(100) into rear of drive shaft(22). Side wear plate(35) complete with seal and back up seal through the housing to the bottom of the gear pockets.
- ※ Be sure to refit the wear plate you marked from this position.

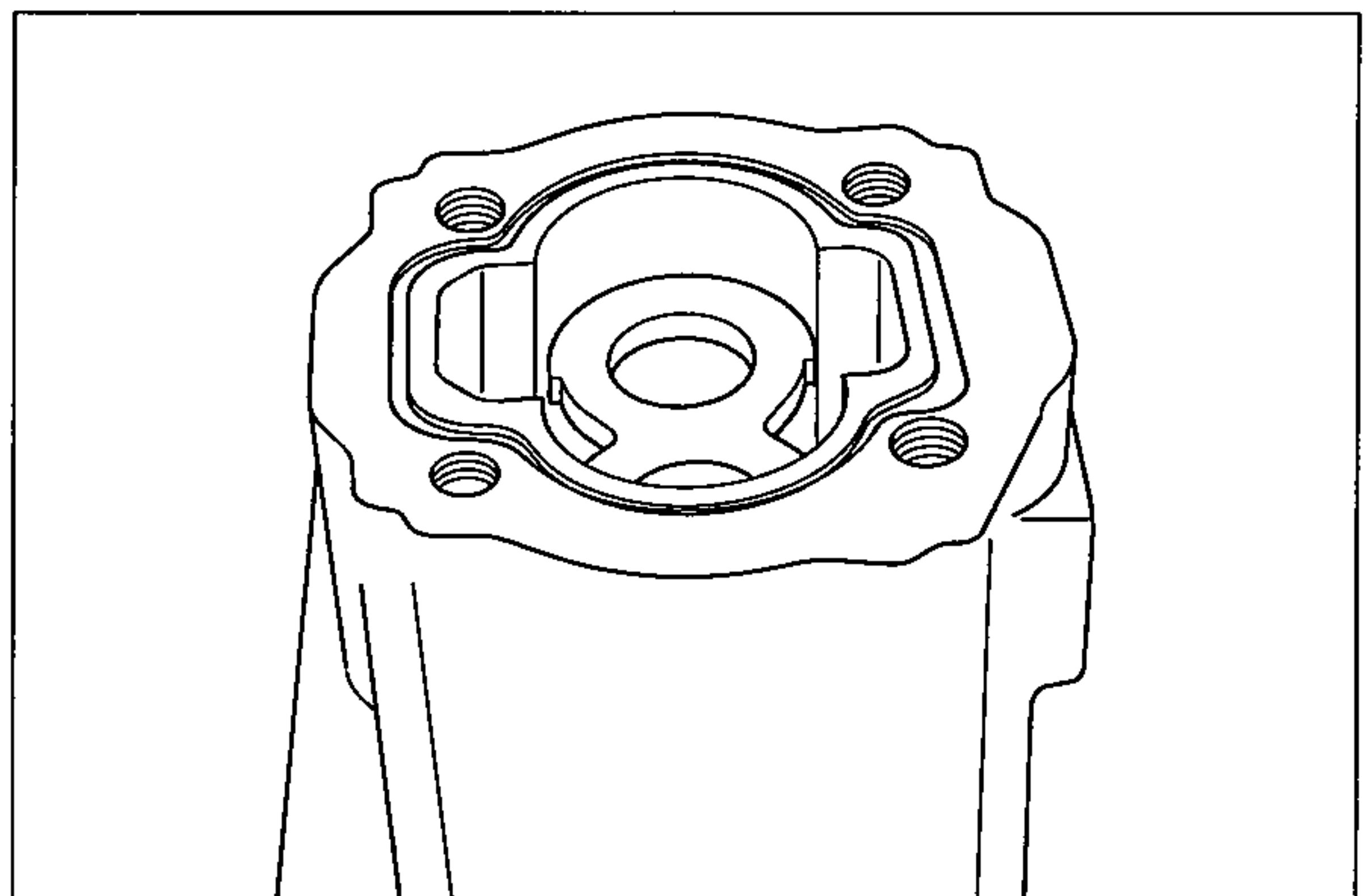

Fit the gears within the housing taking care of replace as marked, with the teeth reassembled to the original related position.

Fit the wear plate(30) complete with seal and back up seal.

※ Be sure to refit the wear plate you have marked from this position.

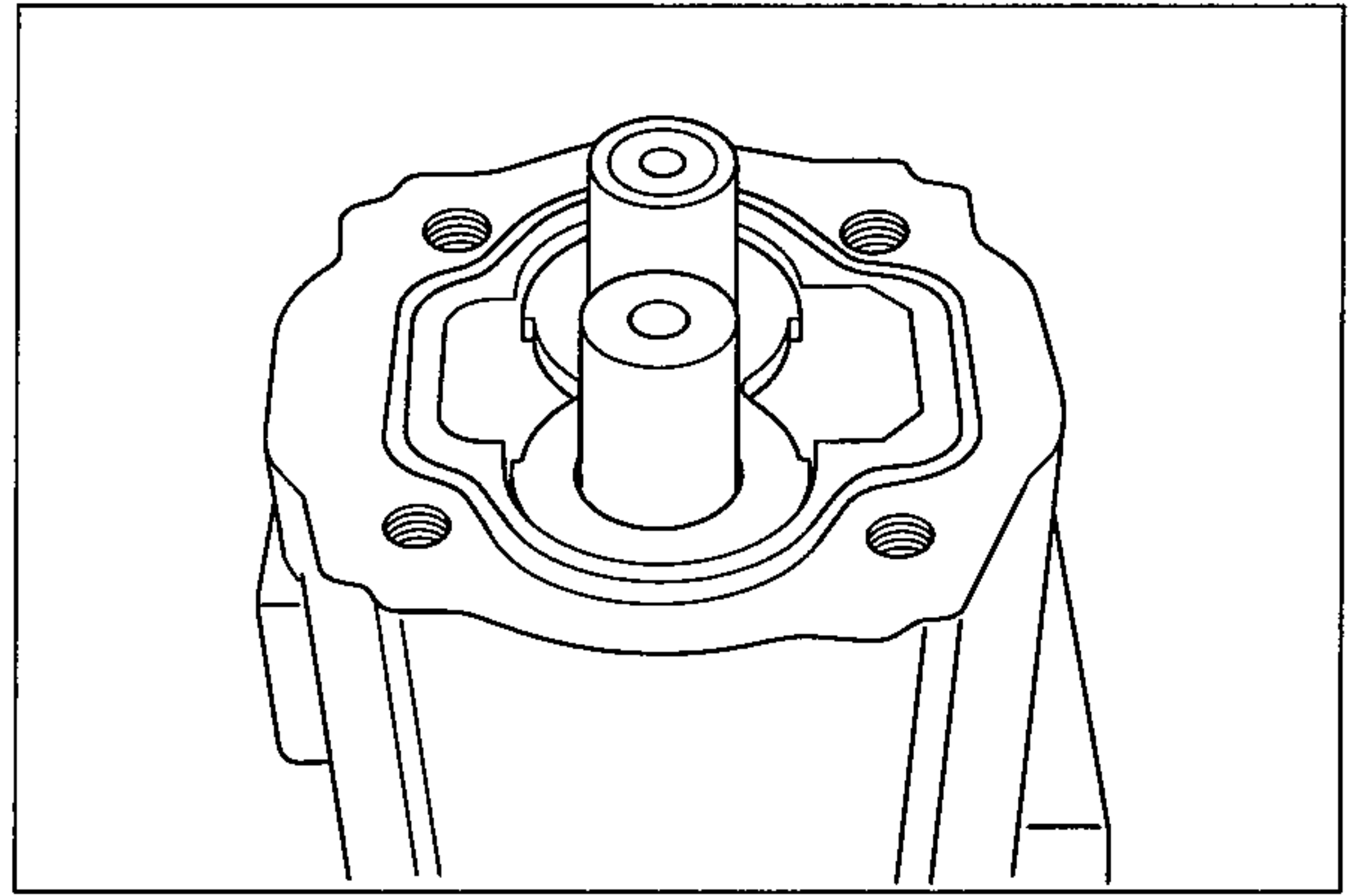

(8) Fit new interface seal(61) into groove in body(4).

Fit rear cover(5) over the gears in the correct orientation and secure with cap screws(81).

Tighten cap screws(81) to half torque and then full torque in diagonal sequence to figure as per assembly.

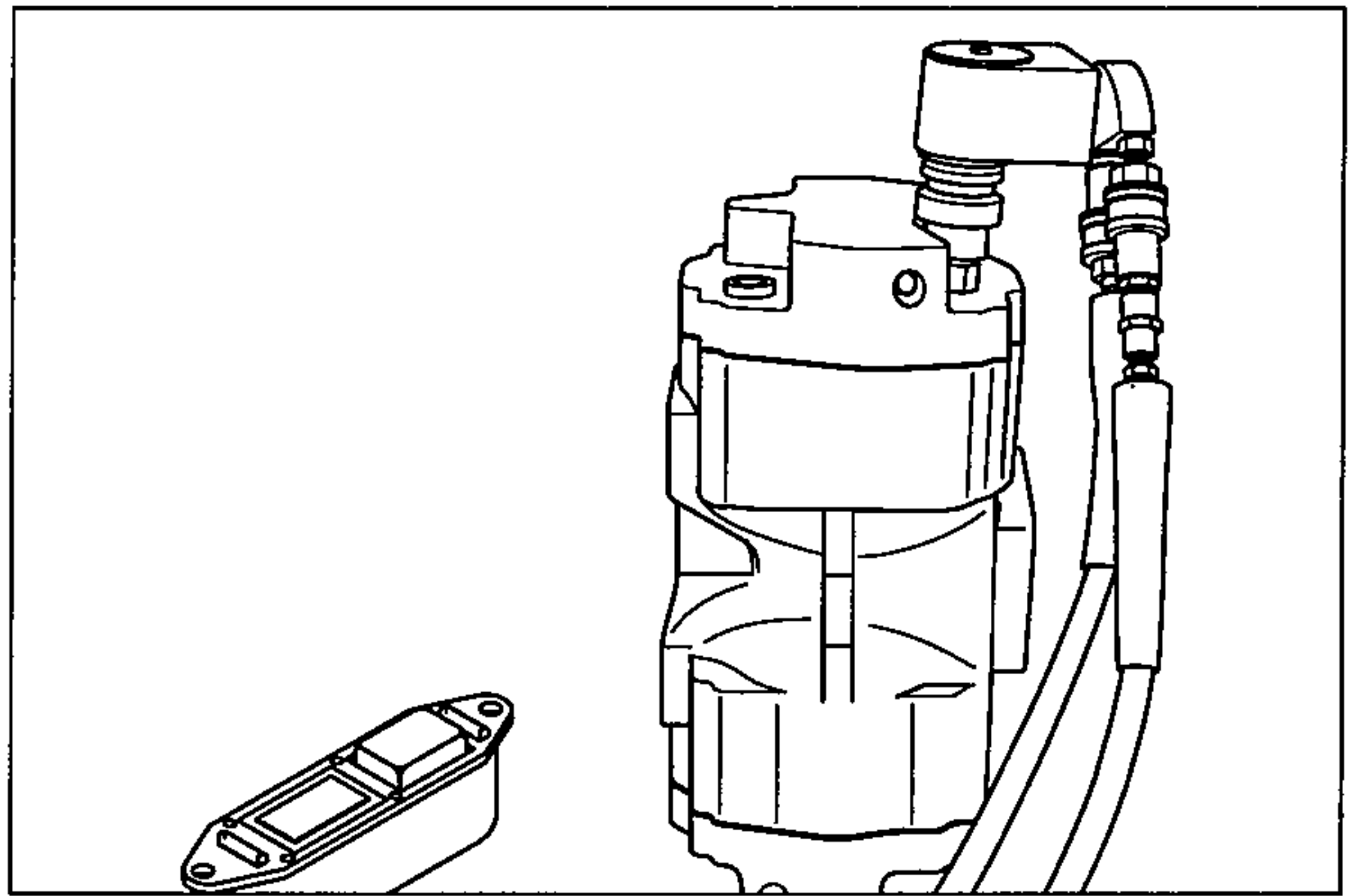

## 2. BOOM AND BUCKET CYLINDER

### 1) BOOM CYLINDER

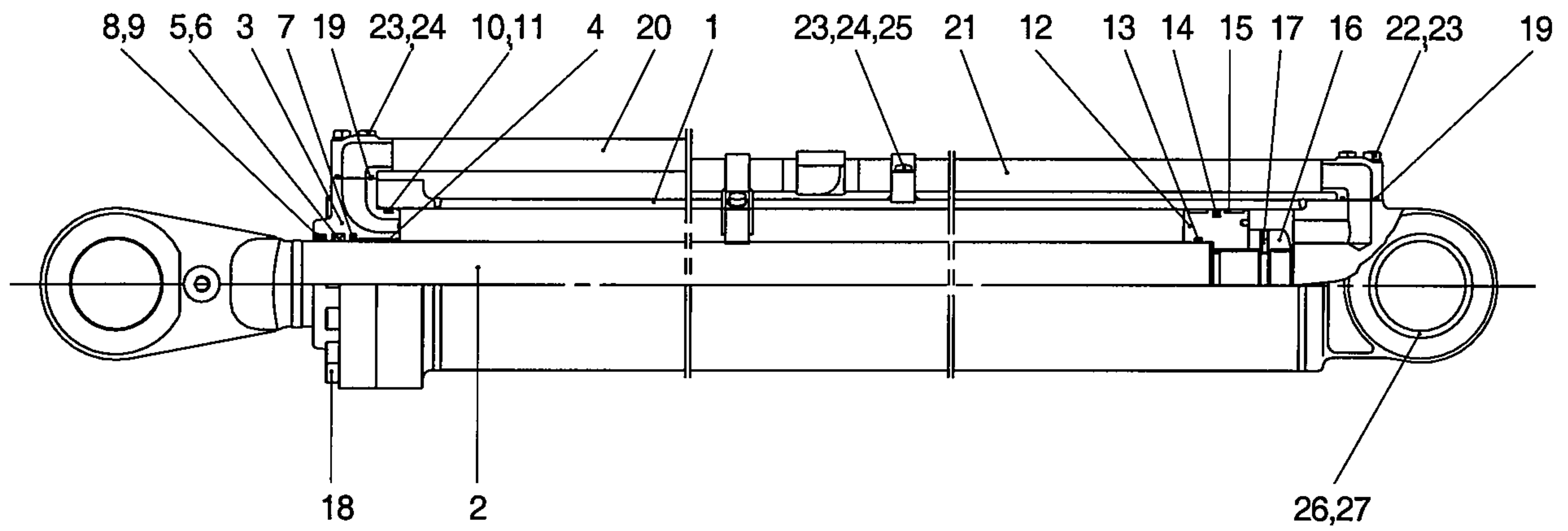

1	Tube assy	10	O-ring	19	O-ring
2	Rod assy	11	Back up ring	20	Pipe assy
3	Gland	12	Piston	21	Pipe assy
4	Bushing	13	O-ring	22	Bolt
5	Rod seal	14	Piston seal	23	Spring washer
6	Back up ring	15	Wear ring	24	Bolt
7	Buffer ring	16	Piston nut	25	Band
8	Dust wiper	17	Screw	26	Bushing
9	Snap ring	18	Bolt	27	Dust seal



# BUCKET CYLINDER

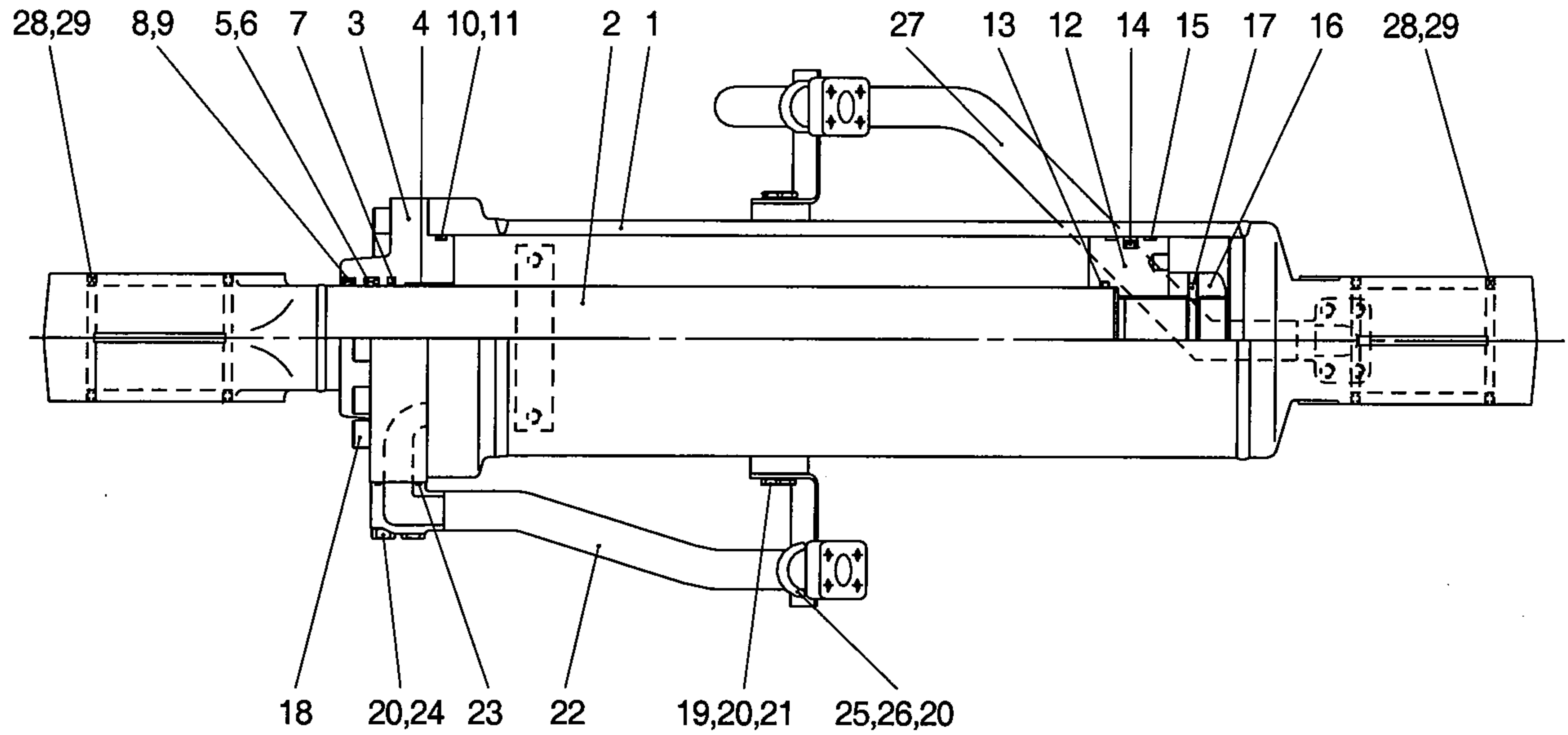

- |    |              |    |               |    |           |
|----|--------------|----|---------------|----|-----------|
| 1  | Tube assy    | 11 | Back up ring  | 21 | Bolt      |
| 2  | Rod assy     | 12 | Piston        | 22 | Pipe assy |
| 3  | Gland        | 13 | O-ring        | 23 | O-ring    |
| 4  | Bushing      | 14 | Piston seal   | 24 | Bolt      |
| 5  | Rod seal     | 15 | Wear ring     | 25 | U-bolt    |
| 6  | Back up ring | 16 | Piston nut    | 26 | Nut       |
| 7  | Buffer ring  | 17 | Screw         | 27 | Pipe assy |
| 8  | Dust wiper   | 18 | Bolt          | 28 | Bushing   |
| 9  | Snap ring    | 19 | Bracket       | 29 | Dust seal |
| 10 | O-ring       | 20 | Spring washer |    |           |

## 2) TOOLS AND TIGHTENING TORQUE

### (1) Tools

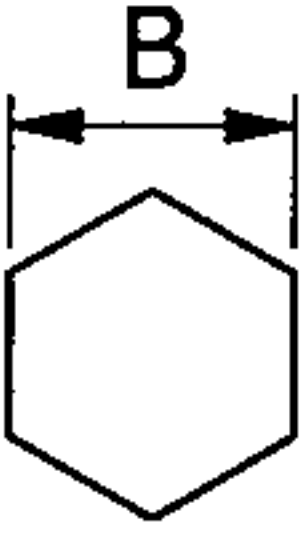
Tool name	Remark	
Allen wrench	8	
	14	
	17	
Spanner	17	
(-) Driver	Small and large sizes	
Torque wrench	Capable of tightening with the specified torques	

### (2) Tightening torque

Part name		Item	Size	Torque	
				kgf · m	lbf · ft
Socket head bolt	Bucket cylinder	18	M18×2.5×65	32±3	231±22
	Boom cylinder	18	M16×2.0×65	23±2	166±14.5
Set screw	Bucket cylinder	17	M10×1.5×12	5.4±0.5	39±3.6
	Boom cylinder	17	M10×1.5×12	5.4±0.5	39±3.6
Piston nut	Bucket cylinder	16	M75×3×48	150±10	1085±72
	Boom cylinder	16	M75×3×55	150±10	1085±72
Piston	Bucket cylinder	12	D180×65	100±15	723±108
	Boom cylinder	12	D160×63	100±15	723±108
Hex head bolt	Bucket cylinder	24	M10×1.5×60	5.4±0.5	39±3.6
	Boom cylinder	22	M10×1.5×60	5.4±0.5	39±3.6

### 3) DISASSEMBLY

#### (1) Remove gland and piston rod

① Hold the clevis section of the tube in a vise. Use mouth pieces so as not to damage the machined surface of the cylinder tube. Do not make use of the outside piping as a locking means.

② Pull out piston rod(2) about 200mm (7.8 in). Because the piston rod is rather heavy, finish extending it with air pressure after the oil draining operation.

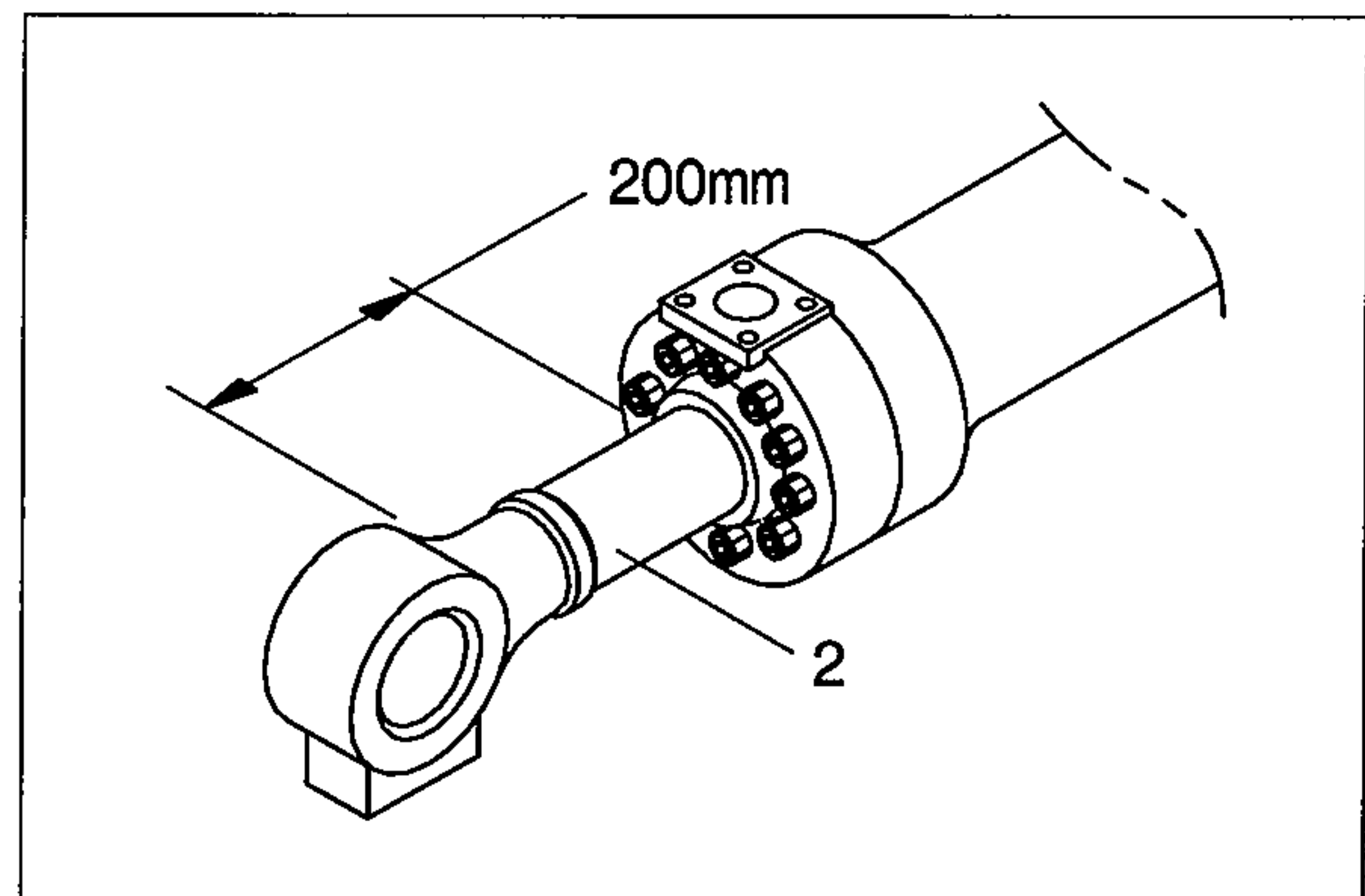

③ Loosen and remove socket bolts(18) of the gland(3) in sequence.

※ Cover the extracted piston rod(2) with rag to prevent it from being accidentally damaged during operation.

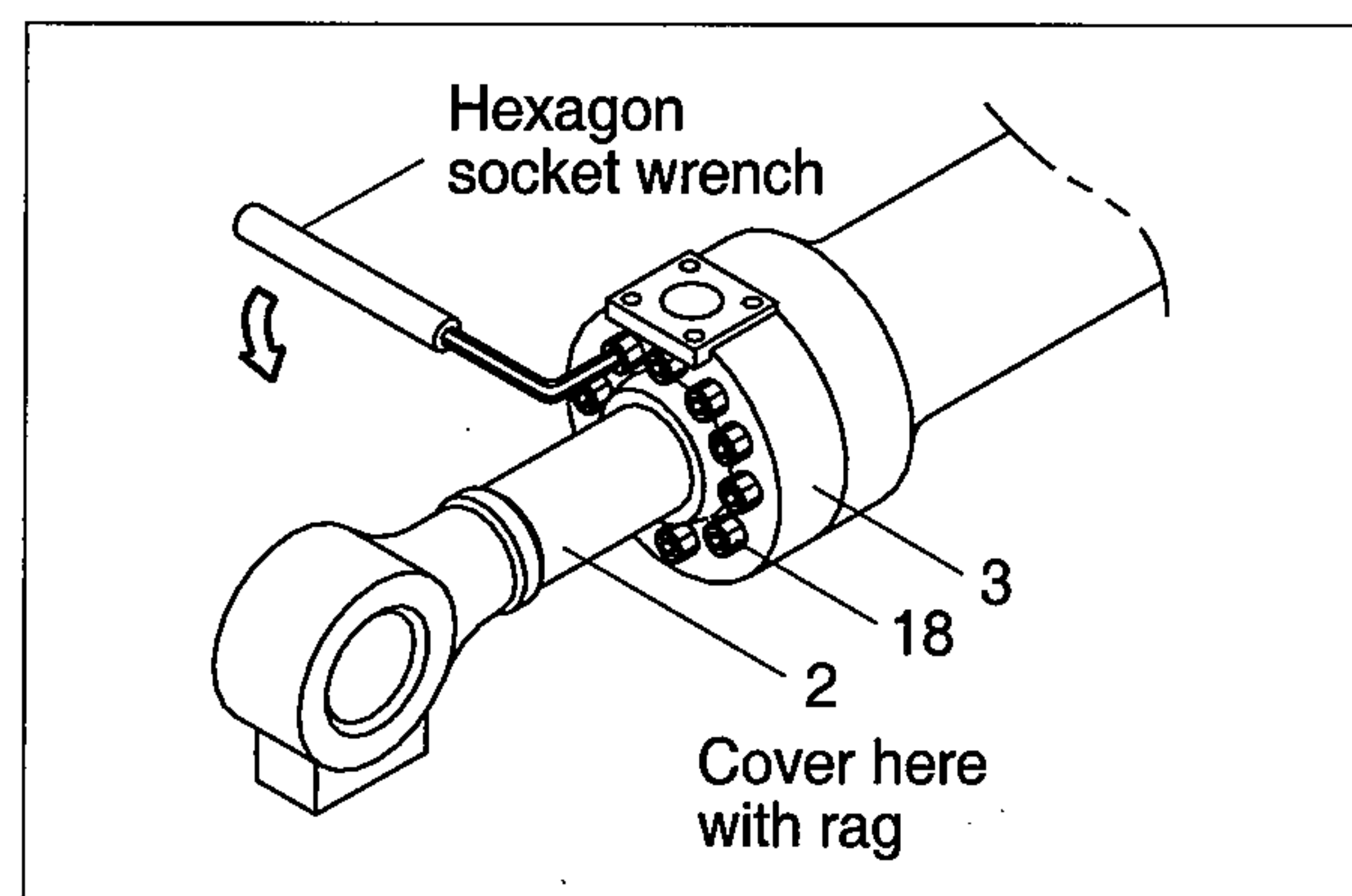

④ Draw out gland(3) and piston rod (2) assembly together from cylinder tube(1).

※ Since the piston rod assembly is heavy in this case, lift the tip of the piston rod(2) with a crane or some means and draw it out. However, when piston rod(2) has been drawn out to approximately two thirds of its length, lift it in its center to draw it completely.

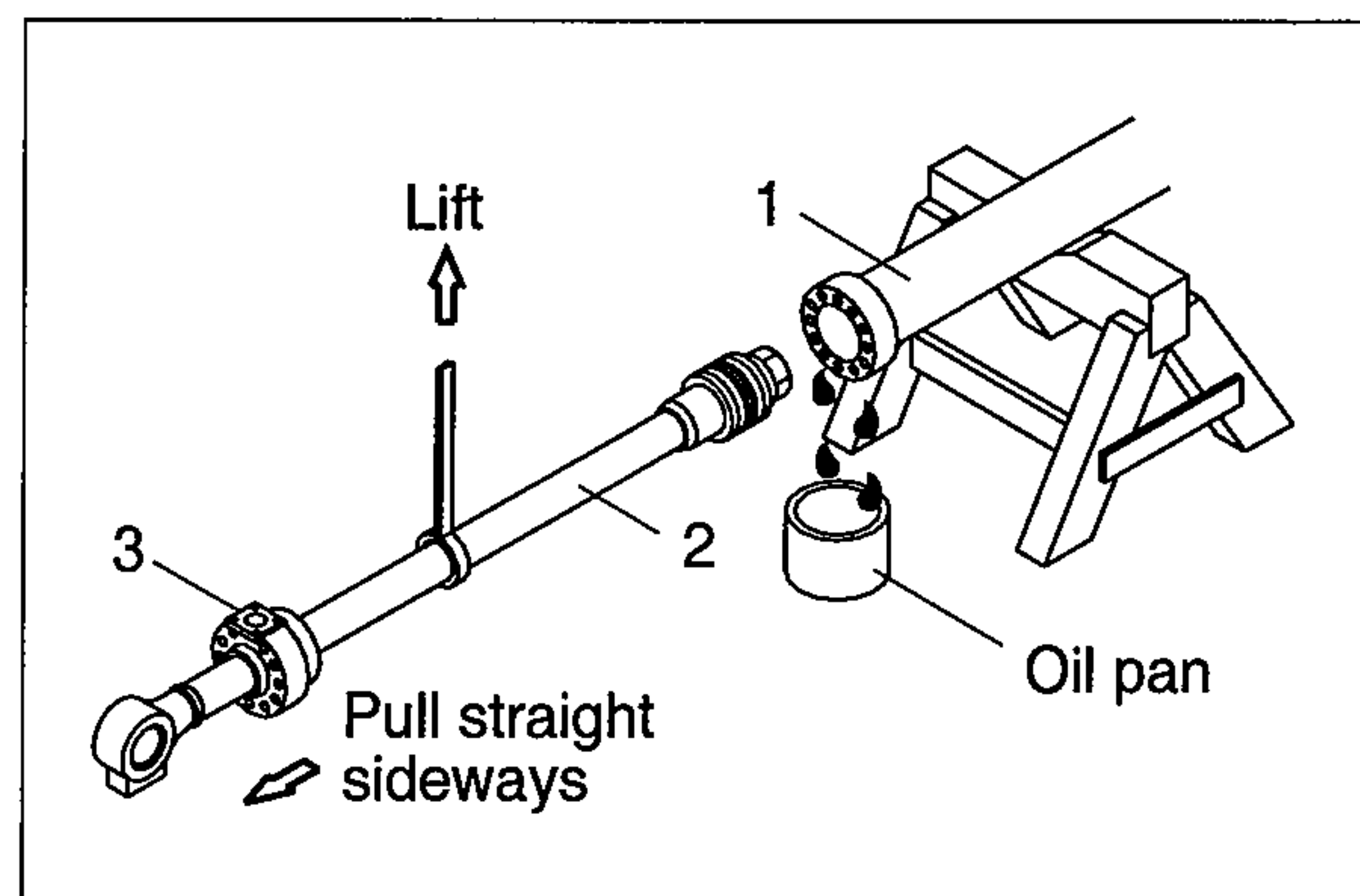

※ Note that the plated surface of piston rod(2) is to be lifted. For this reason, do not use a wire sling and others that may damage it, but use a strong cloth belt or a rope.

⑤ Place the removed piston rod assembly on a wooden V-block that is set level.

※ Cover a V-block with soft rag.

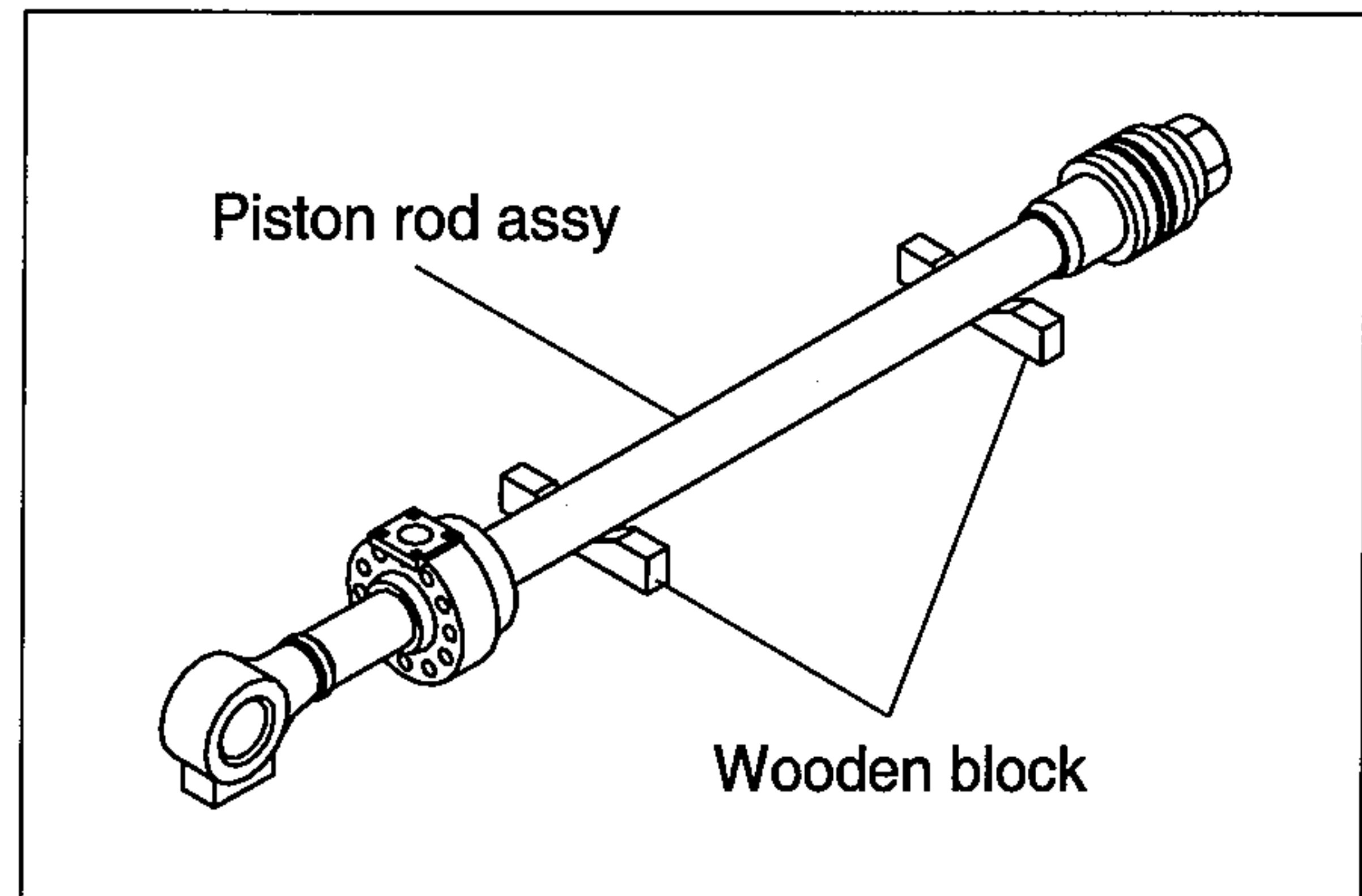

**(2) Remove piston and gland assembly**

① Loosen the screw(17) and remove the piston nut(16).

② Remove piston assembly(12) and O-ring (13).

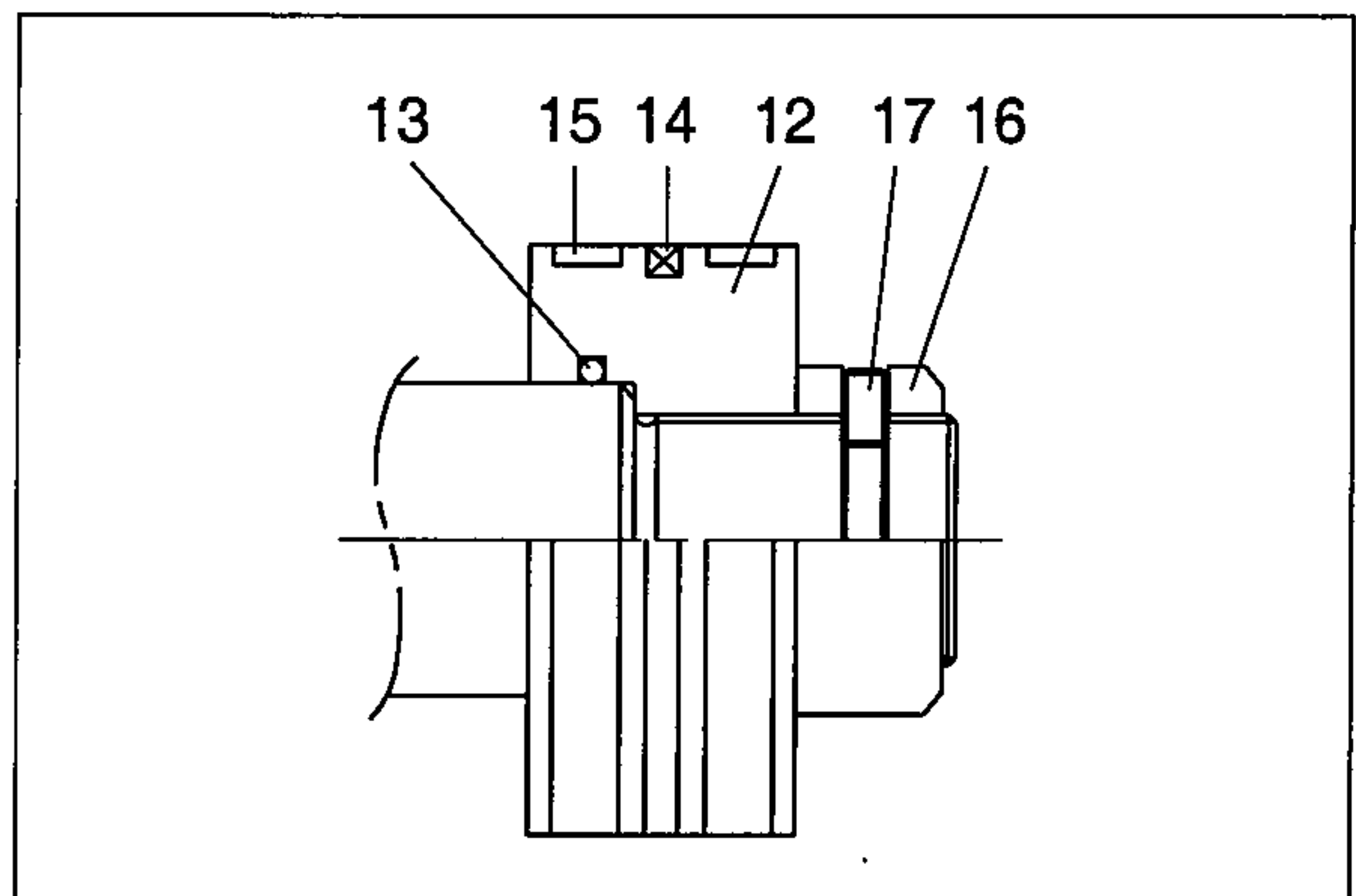

③ Remove the gland assembly from piston rod(2).

※ If is too heavy to move, move it by striking the flanged part of gland(3) with a plastic hammer.

※ Pull it straight with gland assembly lifted with a crane.

Exercise care so as not to damage the lip of rod bushing(4) and packing(5, 6, 7, 8, 9) by the threads of piston rod(2).

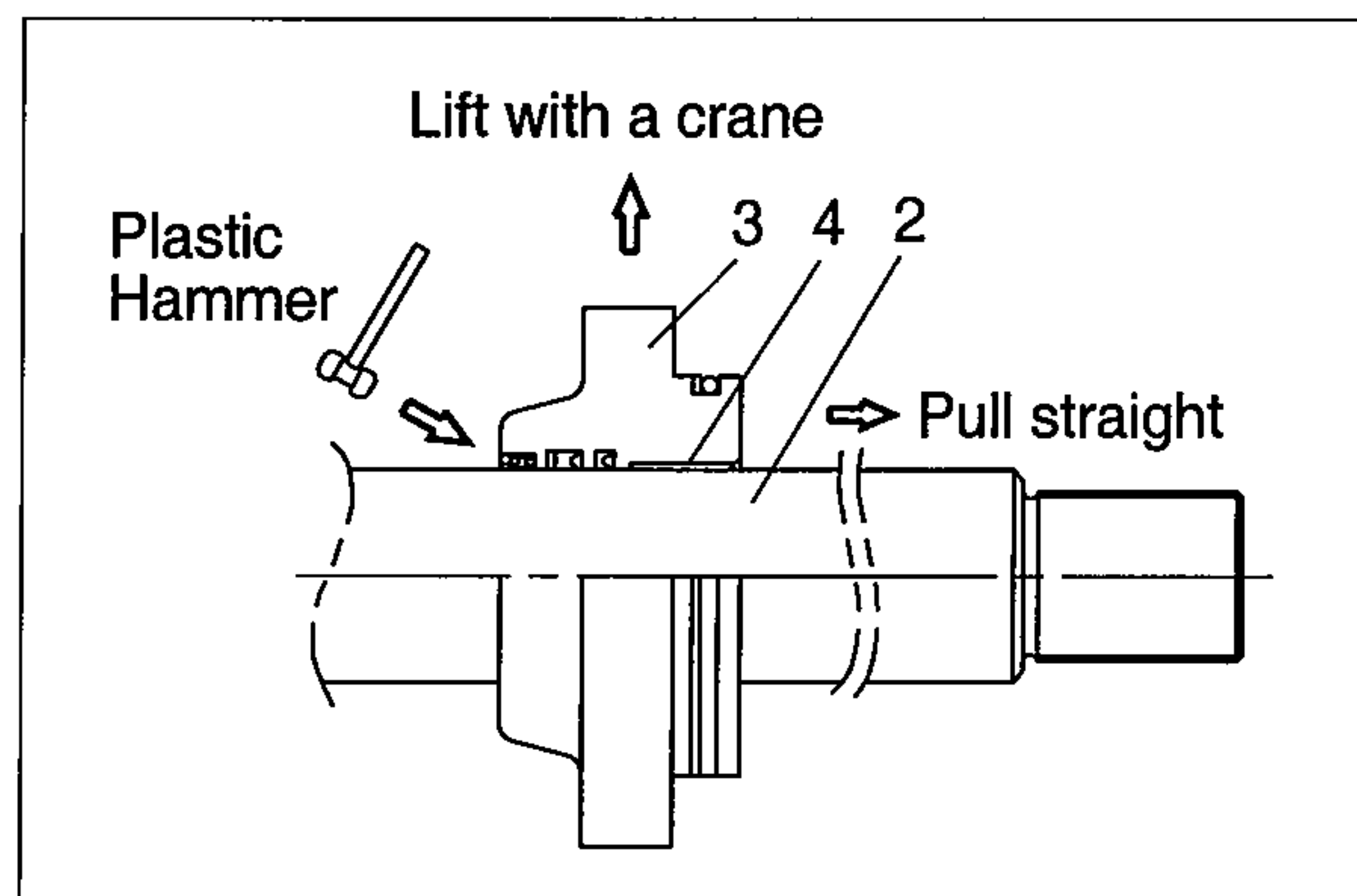



**(3) Disassemble the piston assembly**

- ① Remove wear rings(15) and piston seal (14).
- \* Exercise care in this operation not to damage the grooves.

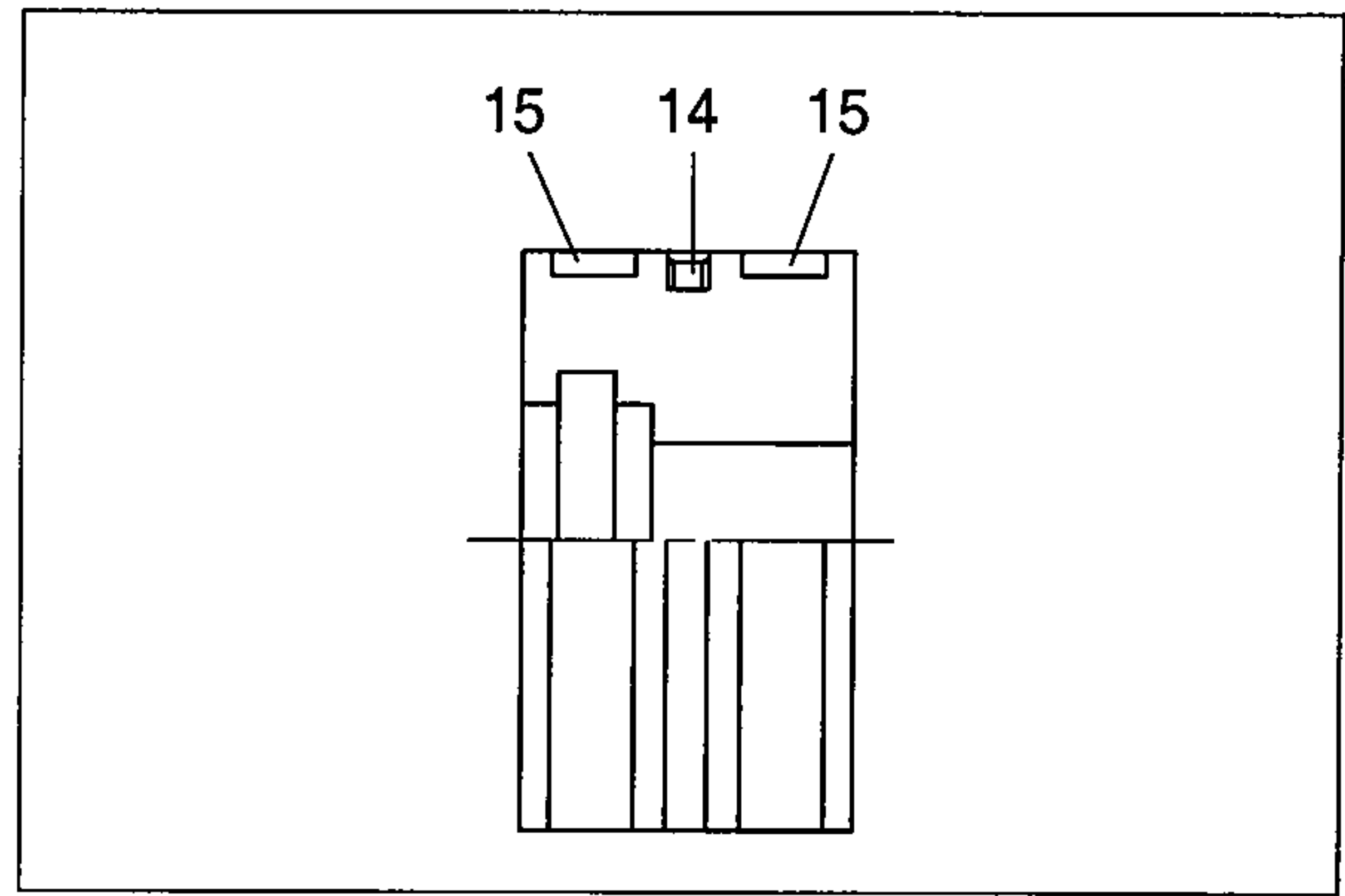

**(4) Disassemble gland assembly**

- ① Remove back up ring(11), and O-ring (10).
- ② Remove snap ring(9) and dust wiper(8).
- ③ Remove back up ring(6), rod seal(5) and buffer ring(7).
- \* Exercise care in this operation not to damage the grooves.
- \* Do not remove seal and ring, if does not damaged.

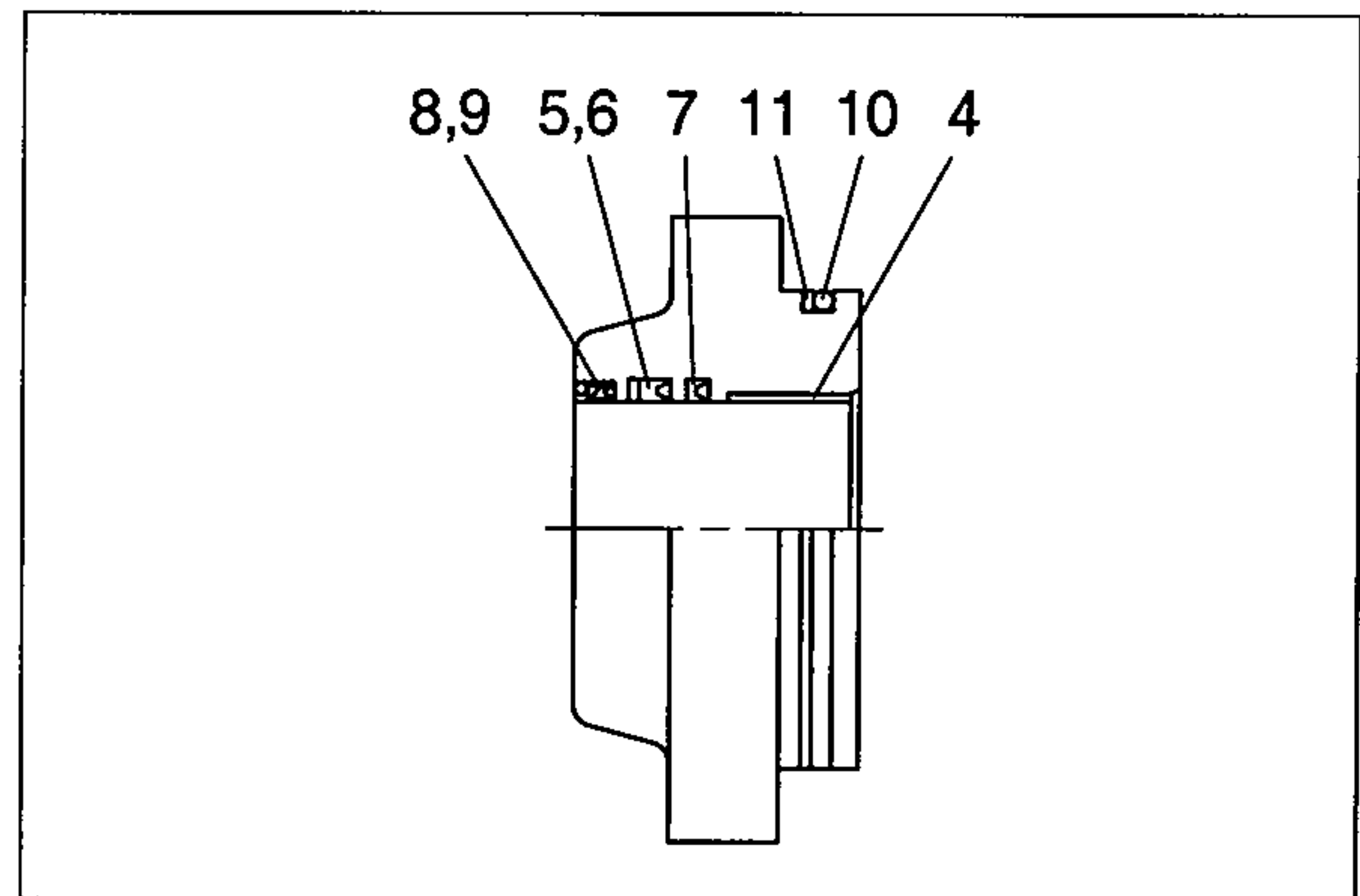

#### 4) ASSEMBLY

##### (1) Assemble gland assembly

※ Check for scratches or rough surfaces if found smooth with an oil stone.

① Coat the inner face of gland(3) with hydraulic oil.

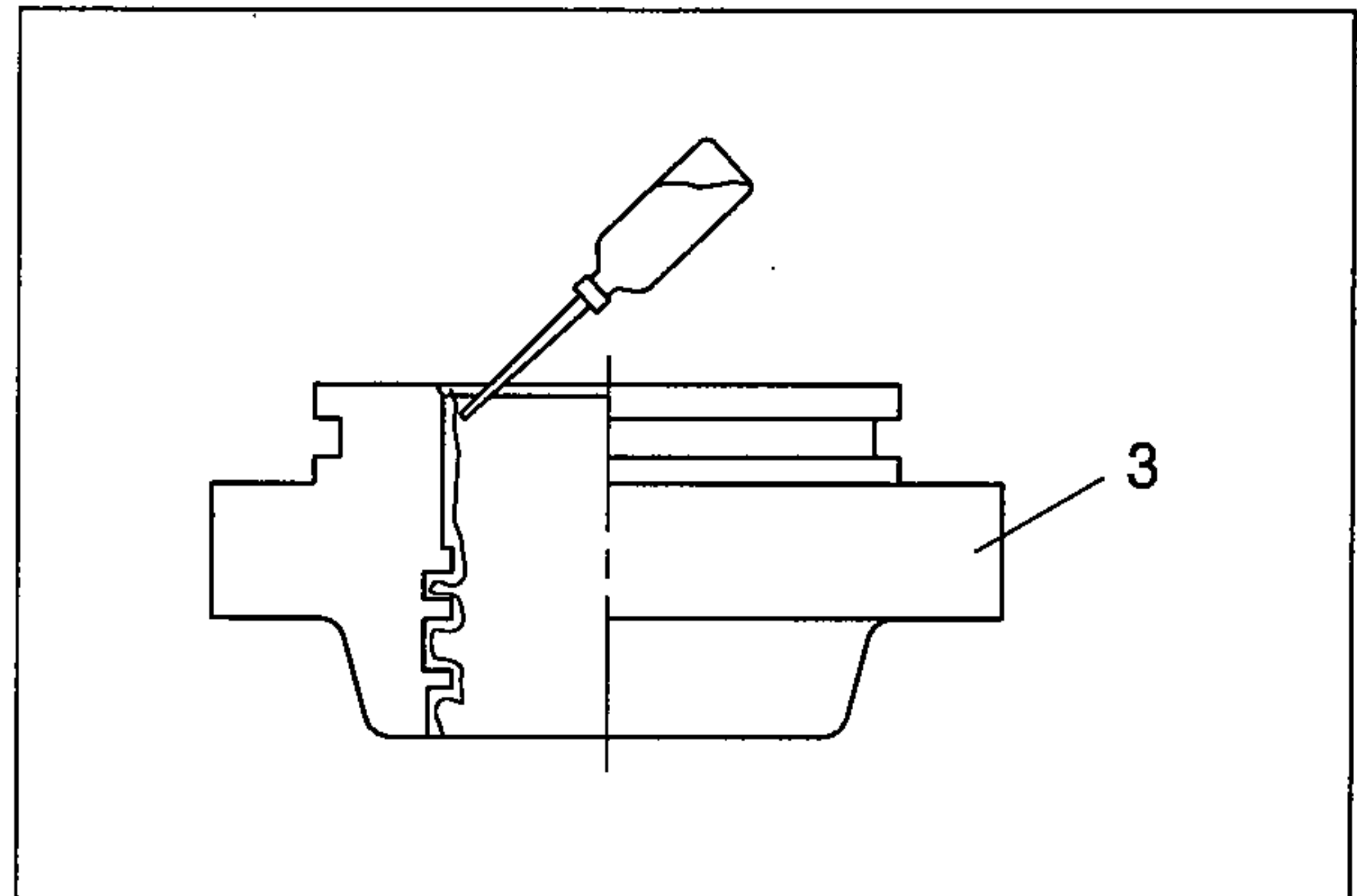

② Coat dust wiper(8) with grease and fit dust wiper(8) to the bottom of the hole of dust wiper.

③ At this time, press a pad metal to the metal ring of dust seal.

Fit snap ring(9) to the stop face.

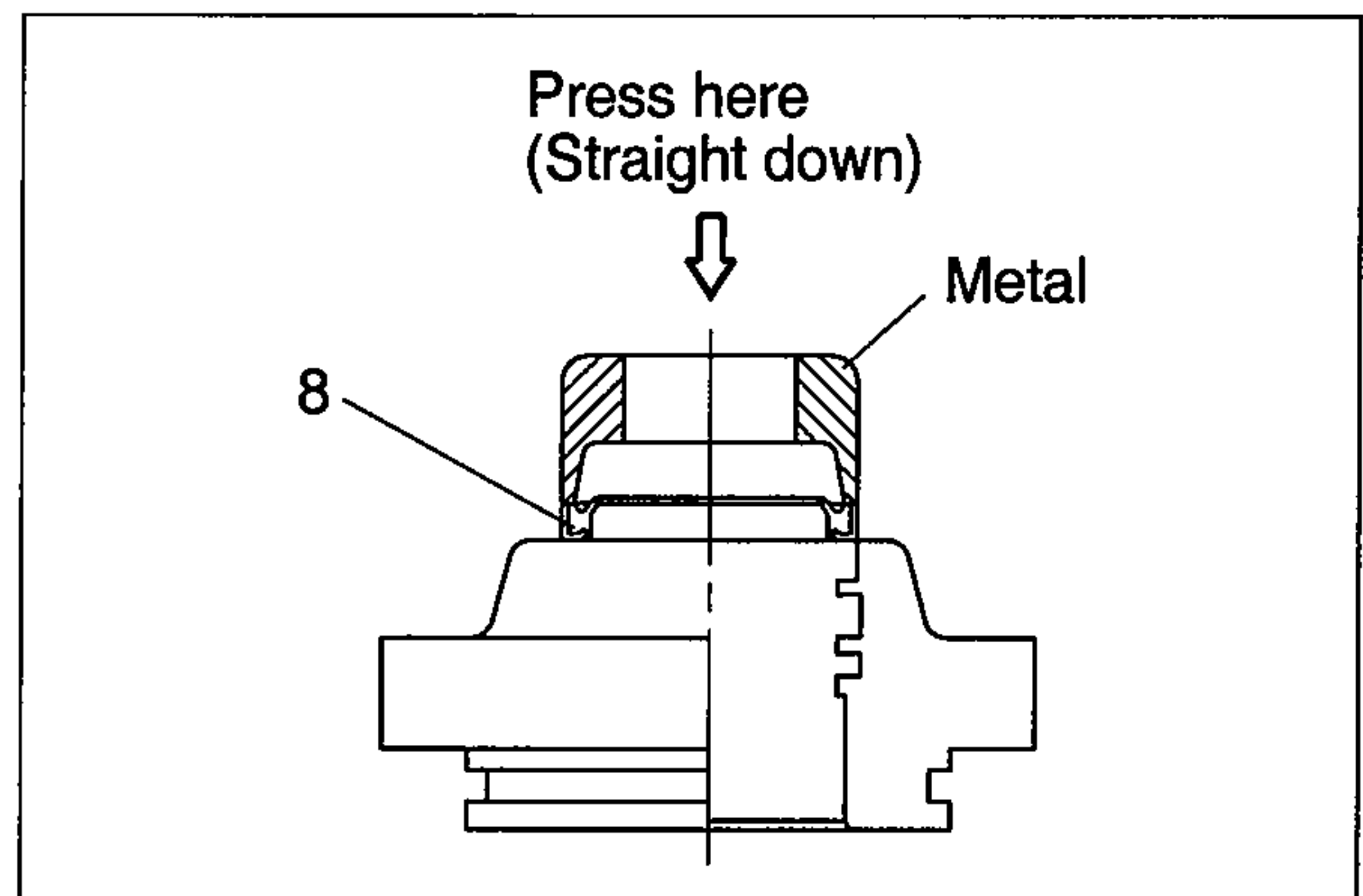

④ Fit back up ring(6), rod seal(5) and buffer ring(7) to corresponding grooves, in that order.

※ Coat each packing with hydraulic oil before fitting it.

※ Insert the backup ring until outside of it is inserted into groove.

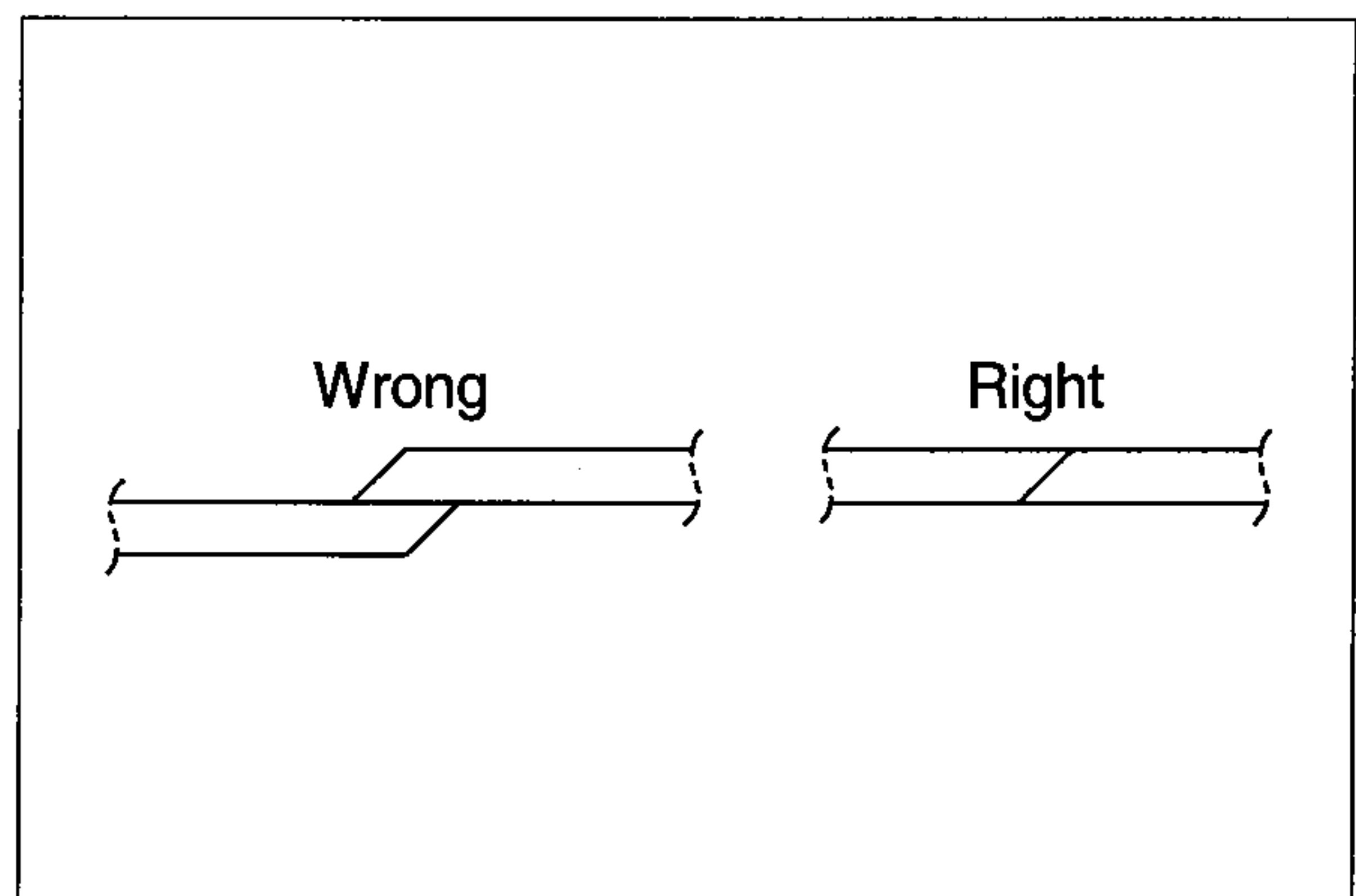

※ Rod seal(5) has its own fitting direction. Therefore, confirm it before fitting them.

※ Fitting rod seal(5) up side down may damage its lip. Therefore check the correct direction that is shown in fig.

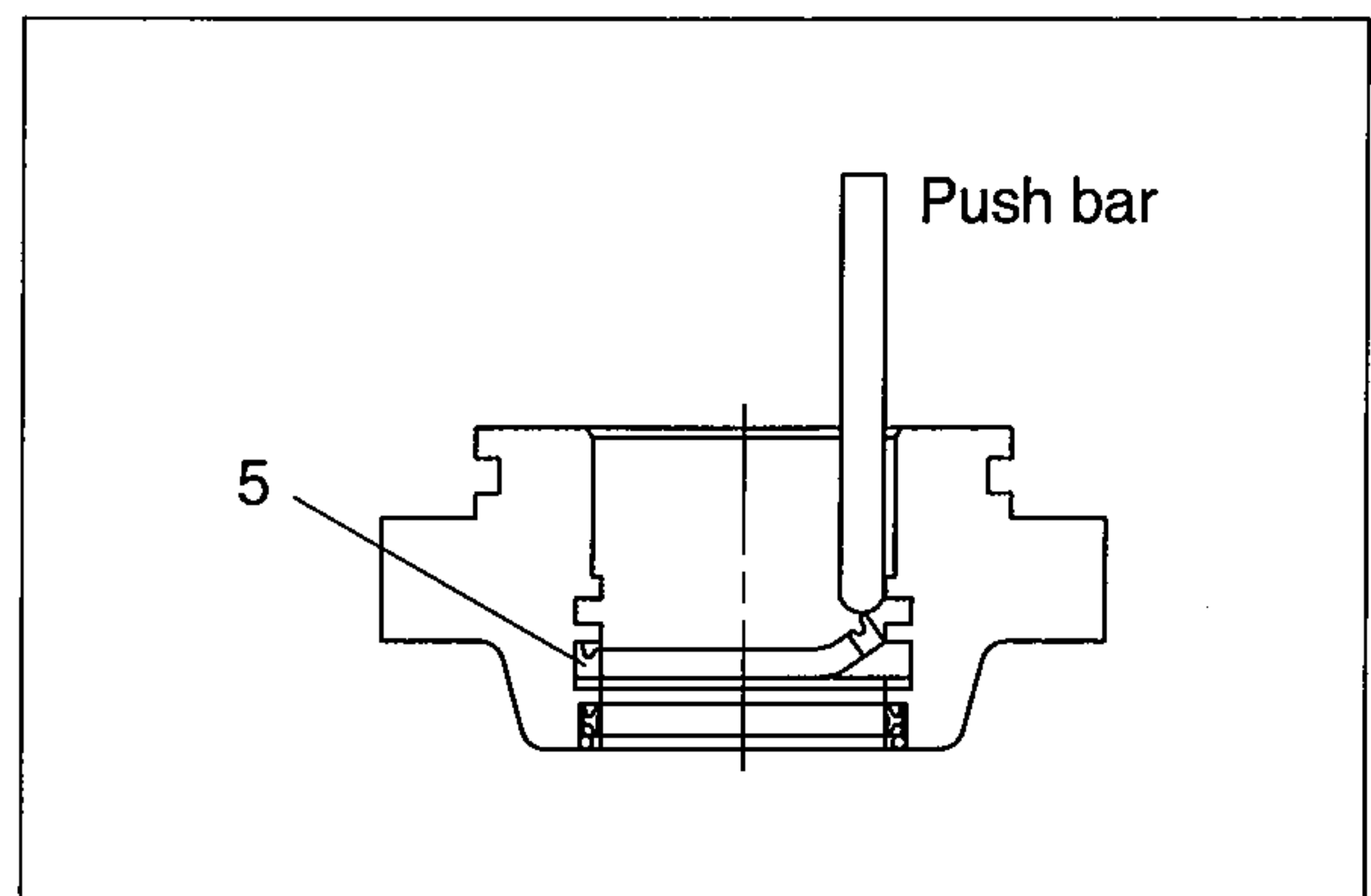

- ⑤ Fit back up ring(11) to gland(3).
- ※ Put the backup ring in the warm water of 30~50°C.
- ⑥ Fit O-ring(9) to gland(3).

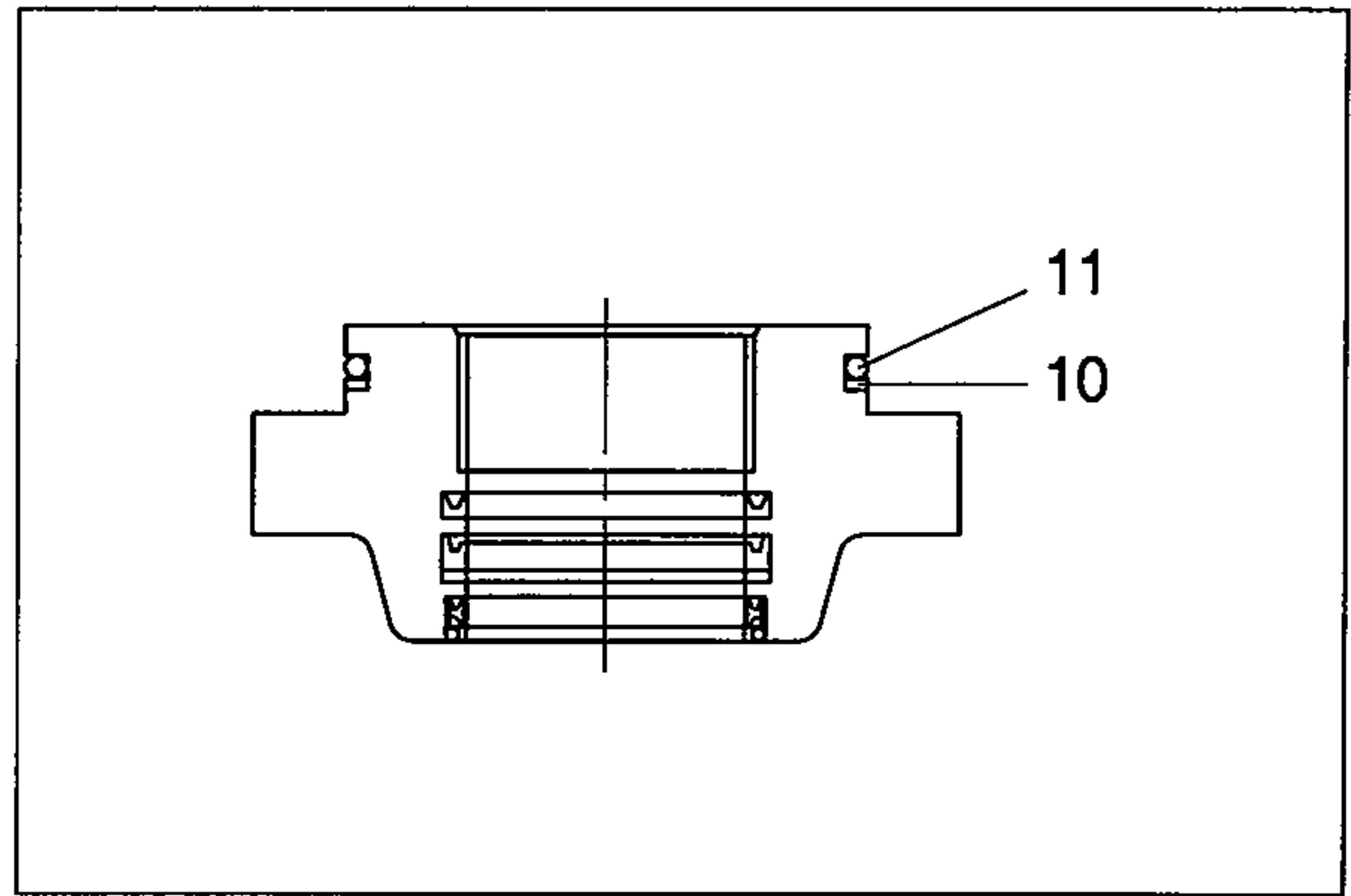

**(2) Assemble piston assembly**

- ※ Check for scratches or rough surfaces if found smooth with an oil stone.
- ① Coat the outer face of piston(12) with hydraulic oil.

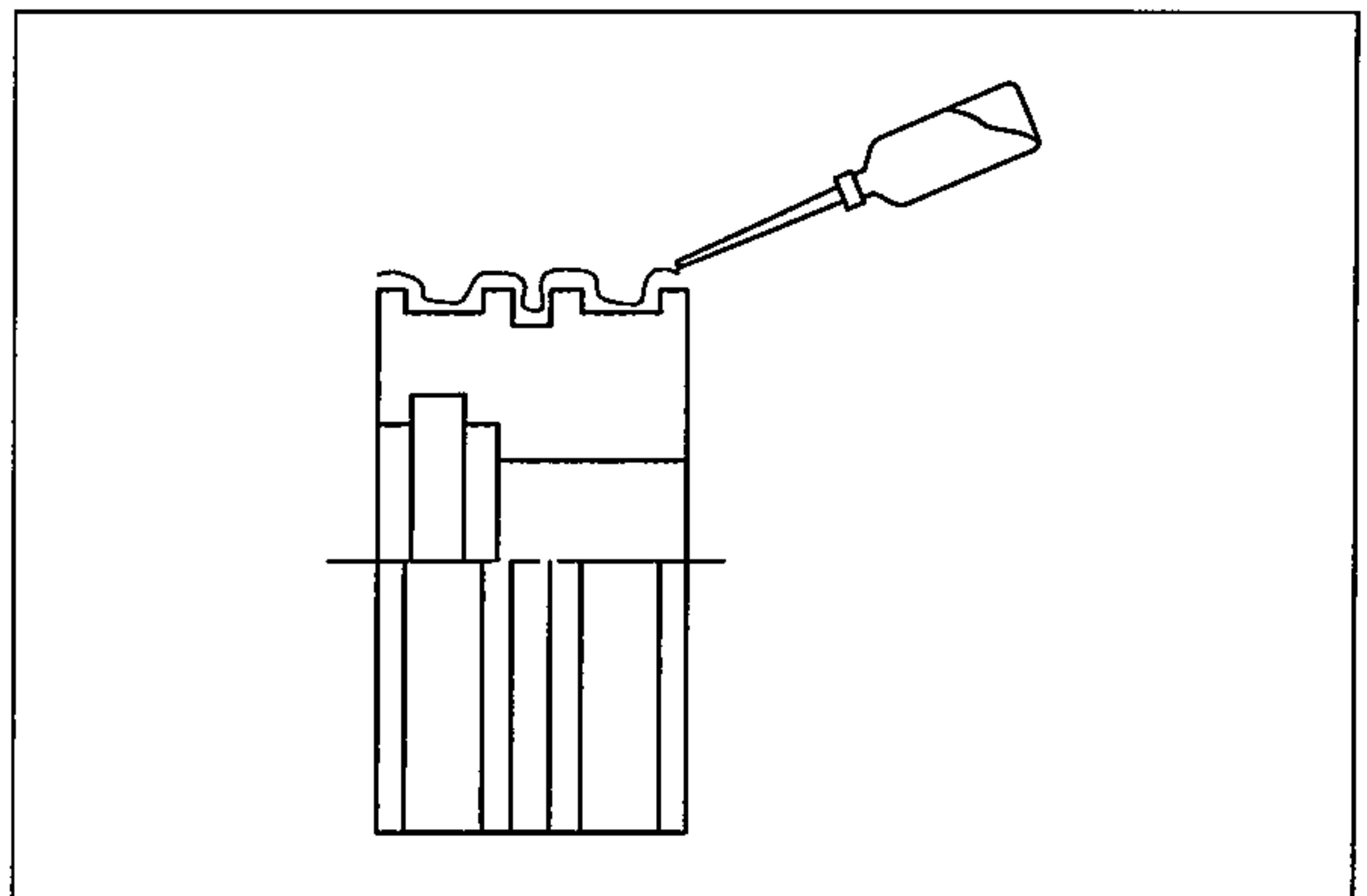

- ② Fit piston seal(14) to piston
- ※ Put the piston seal in the warm water of 60~100°C for more than 5 minutes.
- ※ After assembling the piston seal, press its outer diameter to fit in.

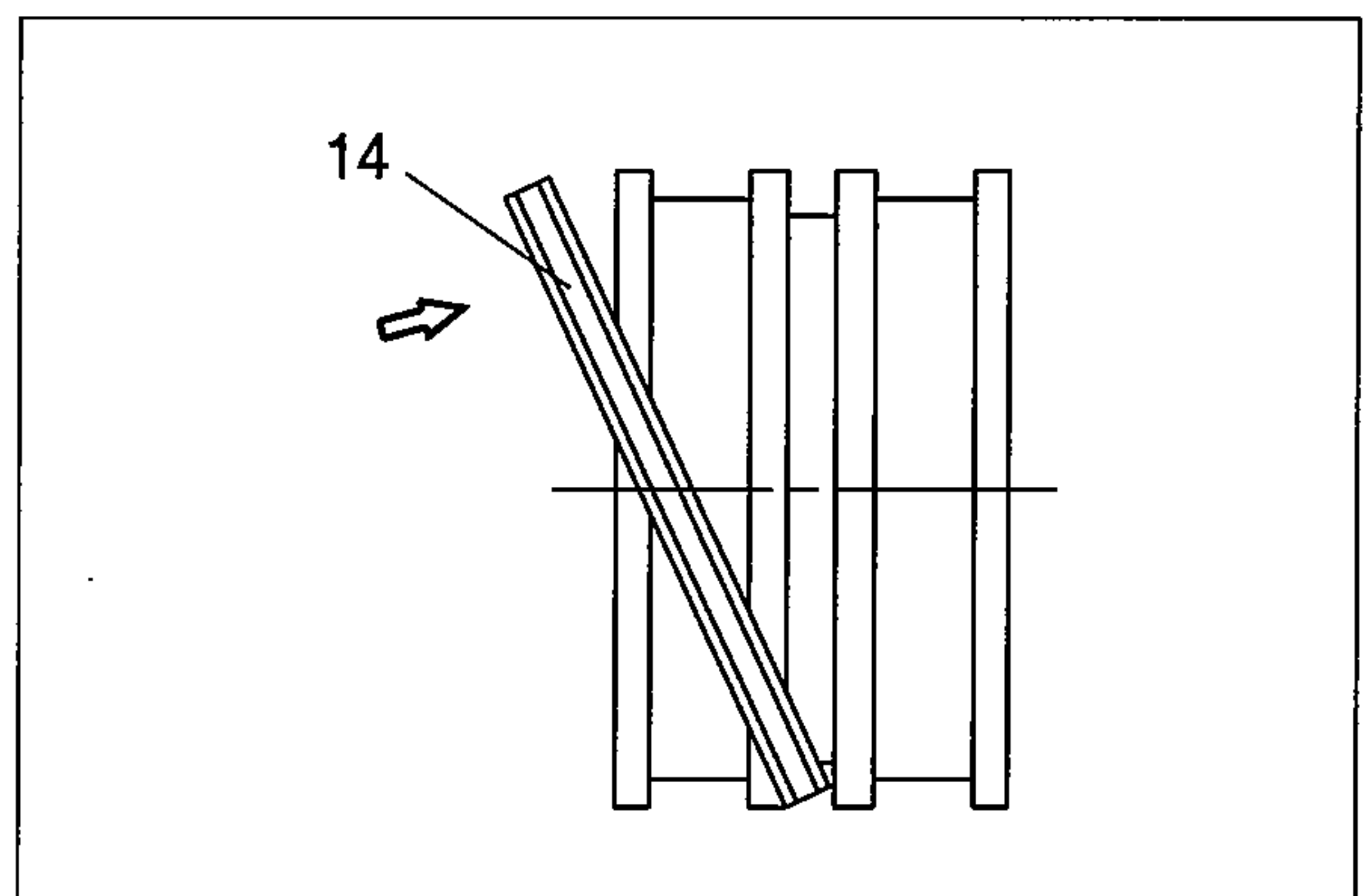

- ③ Fit wear rings(15) to piston(12).
- ④ Fit O-ring(13) to piston(12).

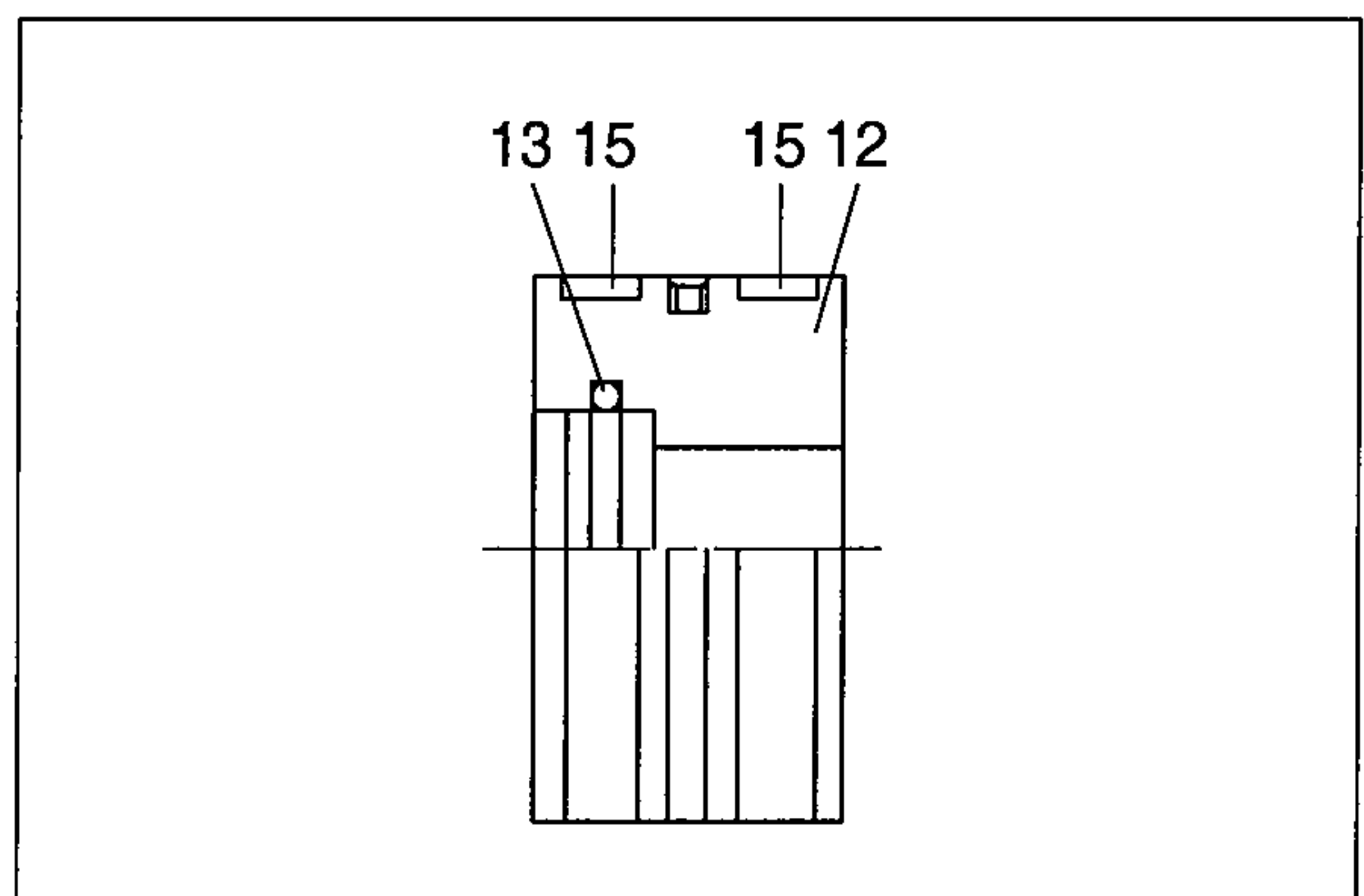

**(3) Install piston and gland assembly**

- ① Fix the piston rod assembly to the work bench.
- ② Apply hydraulic oil to the outer surface of piston rod(2), the inner surface of piston and gland.
- ③ Insert gland assembly to piston rod(2).

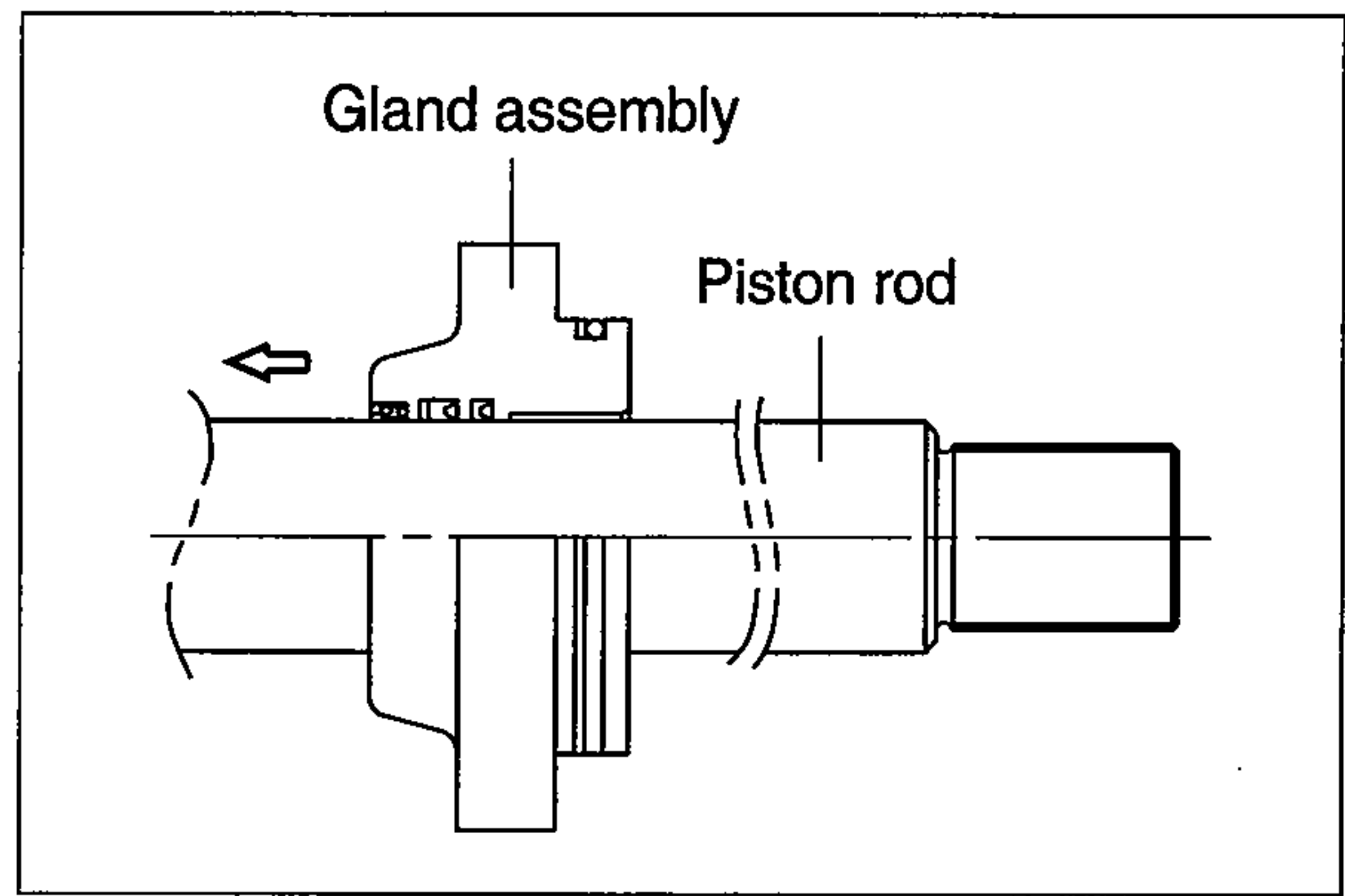

④ Fit piston assembly to piston rod.

- Tightening torque :  $100 \pm 10 \text{ kgf} \cdot \text{m}$   
 $(723 \pm 72 \text{ lbf} \cdot \text{ft})$

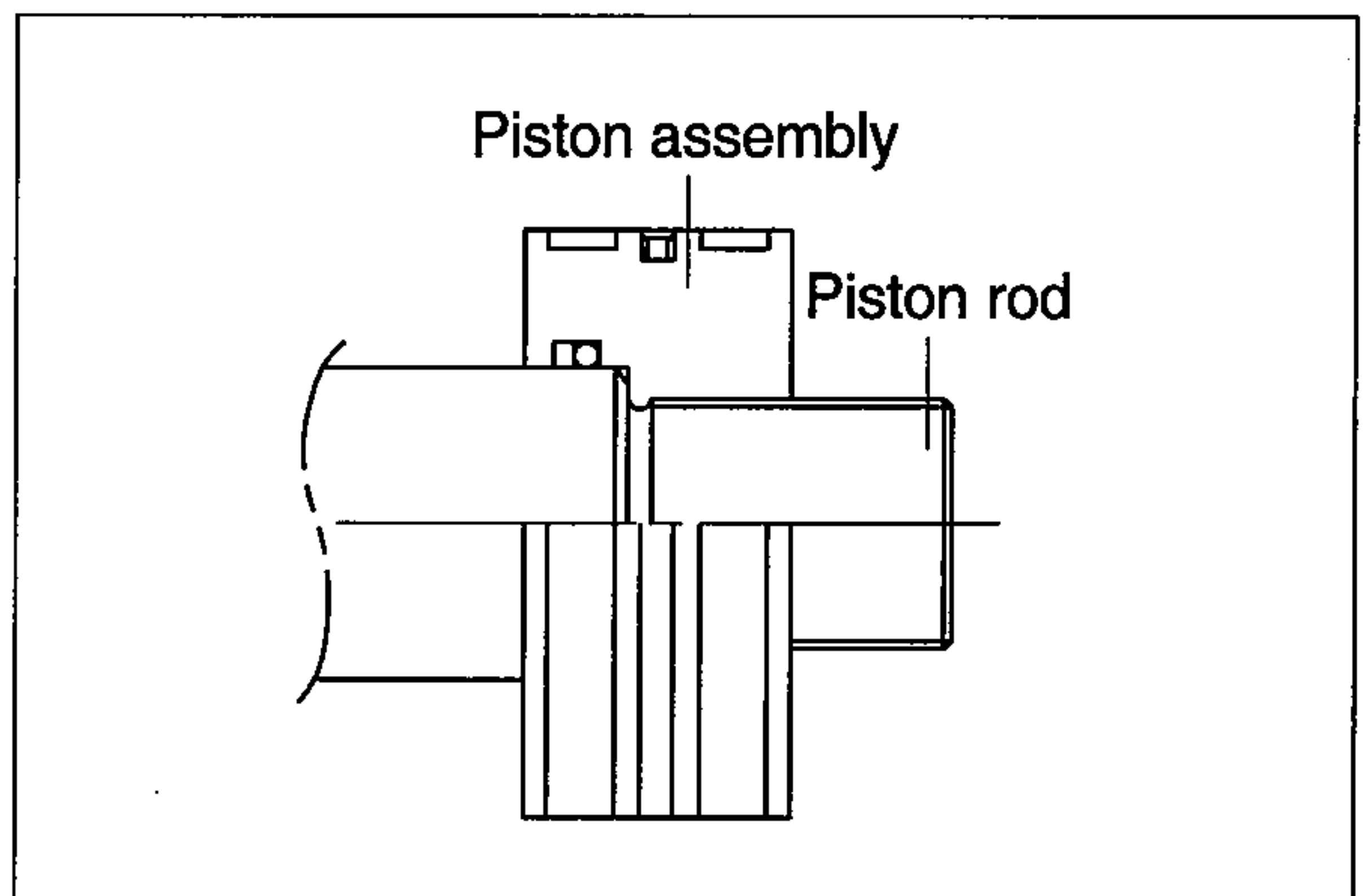

⑤ Tighten piston nut(16) and screw(17) to piston rod(2)

- Tightening torque

Item	kgf · m	lbf · ft
16	$150 \pm 10$	$1085 \pm 72$
17	$5.4 \pm 0.5$	$39 \pm 3.6$

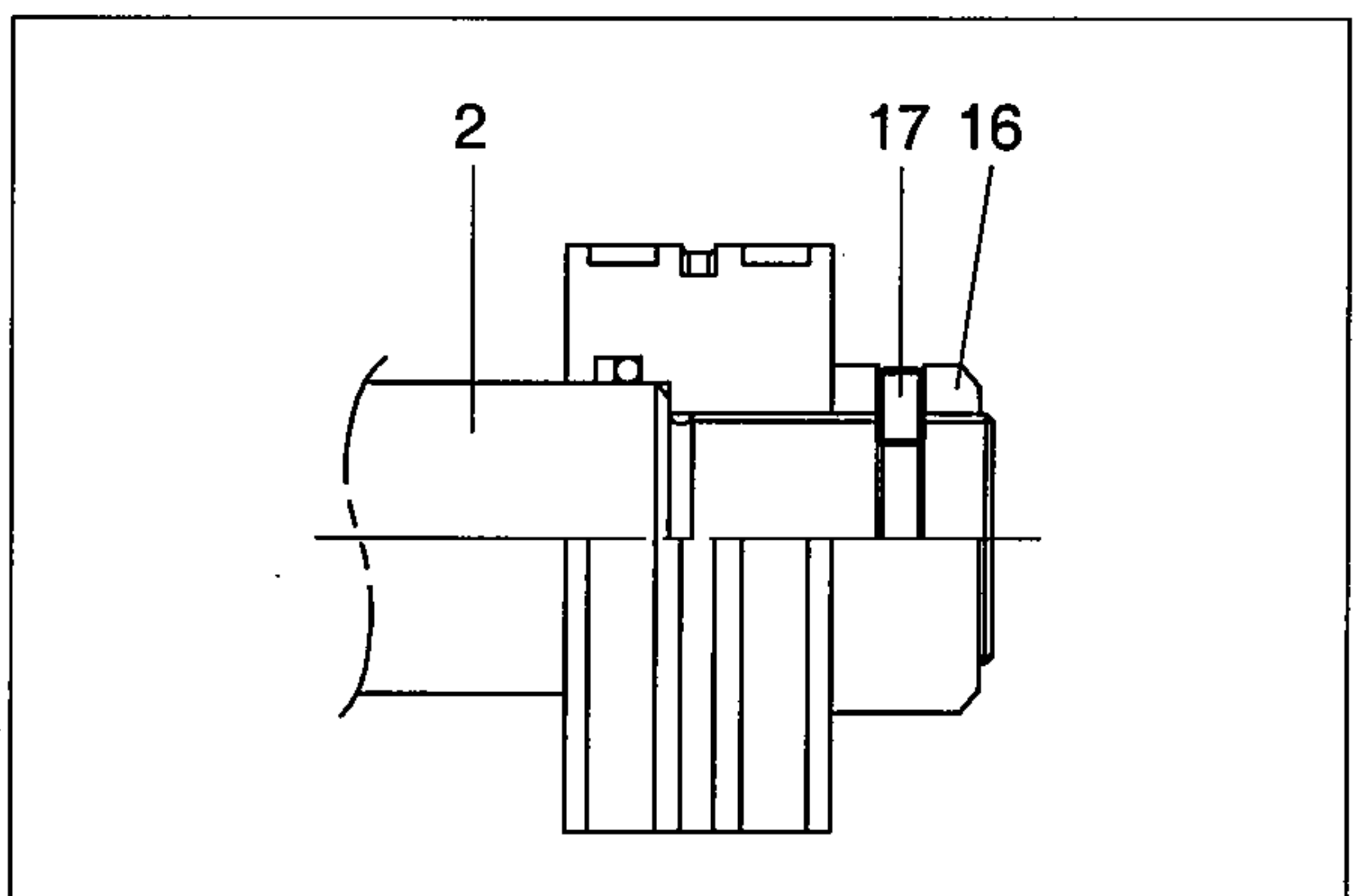



#### (4) Overall assemble

- ① Place a V-block on a rigid work bench.  
Mount the cylinder tube assembly(1) on it and fix the assembly by passing a bar through the clevis hole to lock the assembly.
  - ② Insert the piston rod assembly in to the cylinder tube assembly, while lifting and moving the piston rod assembly with a crane.
- \* Be careful not to damage piston seal by thread of cylinder tube.
- ③ Match the bolts holes in the cylinder head flange to the tapped holes in the cylinder tube assembly and tighten socket bolts to a specified torque.
- \* Refer to the table of tightening torque.

