

SECTION 7 ELECTRICAL SYSTEM

GROUP 1 COMPONENT LOCATION

1. LOCATION 1

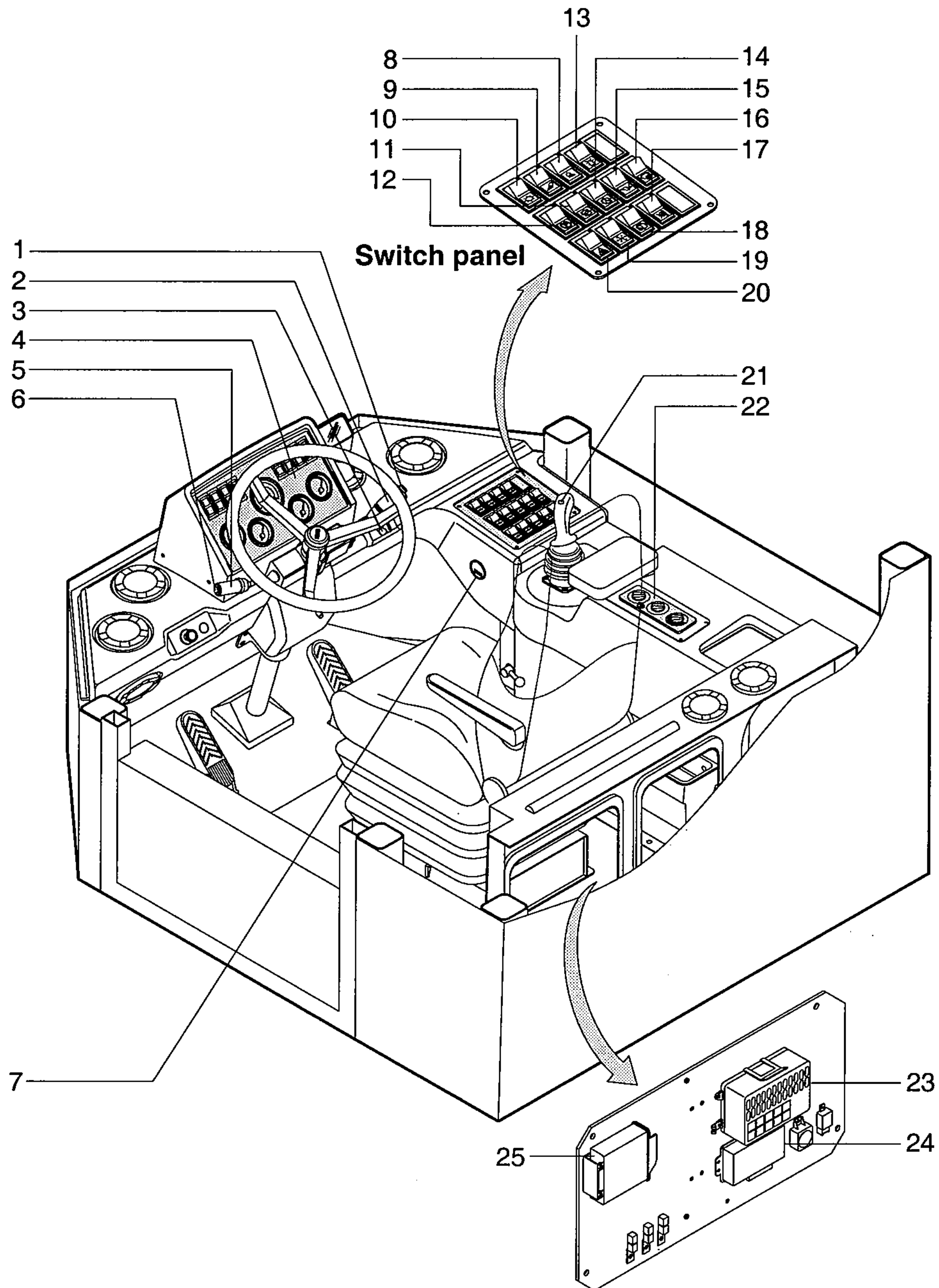

- | | | | | | |
|---|------------------------|----|-------------------------------|----|--------------------------|
| 1 | Horn button | 10 | Main light switch | 18 | Rear wiper/washer switch |
| 2 | Multi function switch | 11 | Clutch cut off switch | 19 | Aircon switch |
| 3 | Starting switch | 12 | Parking brake switch | 20 | Harzard switch |
| 4 | Cluster | 13 | Beacon switch(Optional) | 21 | Kick down switch |
| 5 | Gear selector lever | 14 | Full automatic switch | 22 | Aircon and heater switch |
| 6 | Kick down switch | 15 | Ride control switch(Optional) | 23 | Fuse box |
| 7 | Service meter | 16 | Cold start switch(Optional) | 24 | Check unit |
| 8 | Rear work lamp switch | 17 | Buzzer stop switch | 25 | Control unit |
| 9 | Front work lamp switch | | | | |

2. LOCATION 2

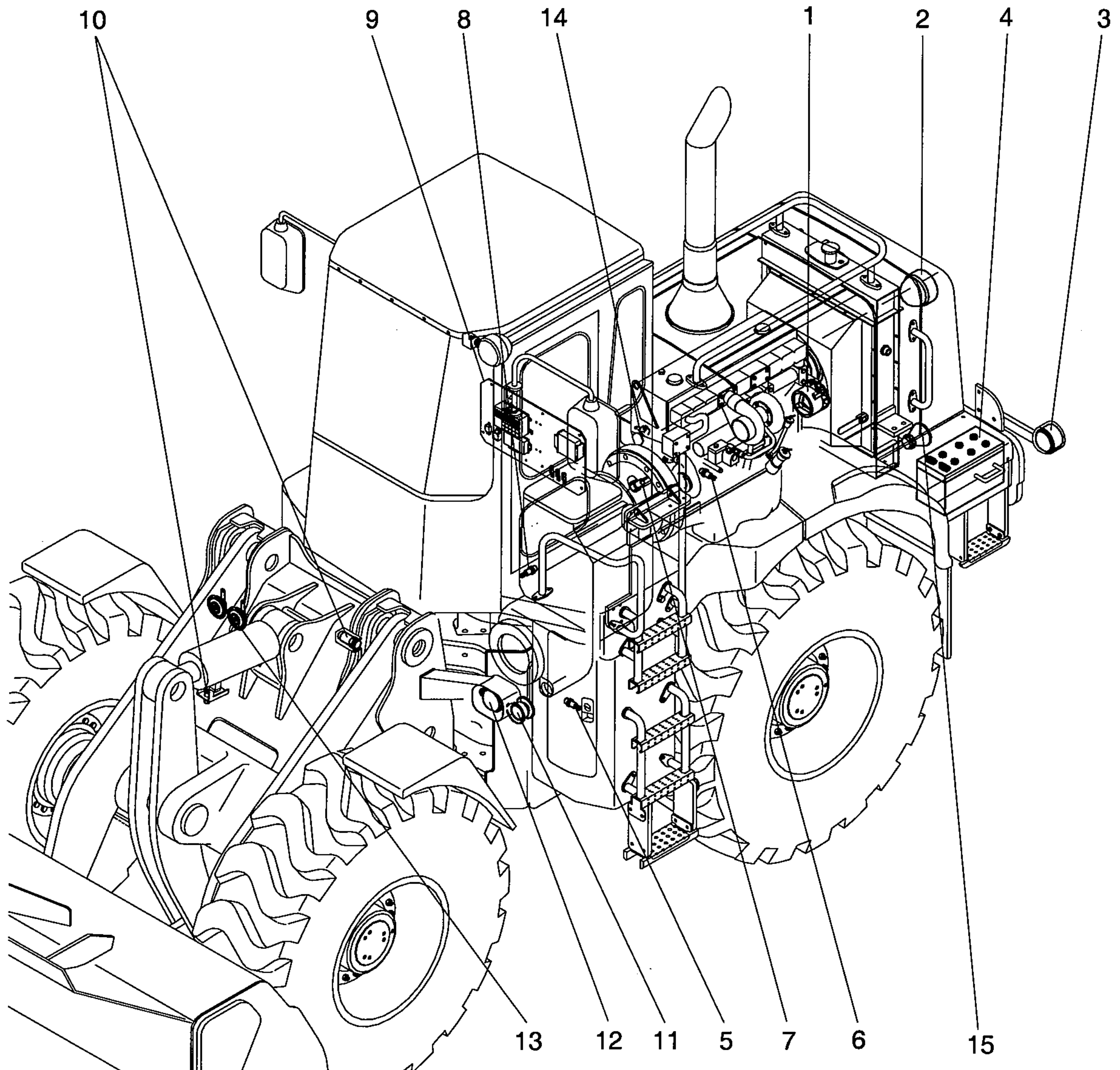

- | | | | | | |
|---|-----------------------|----|---------------------|----|----------------------------|
| 1 | Alternator | 6 | Coolant temp sendor | 11 | Front combination lamp |
| 2 | Light | 7 | T/M temp sendor | 12 | Light |
| 3 | Rear combination lamp | 8 | Pressure switch | 13 | Air horn |
| 4 | Battery | 9 | Relay board | 14 | Engine oil pressure switch |
| 5 | Overheat switch | 10 | Proximate switch | 15 | Back up buzzer |