

## SECTION 7 ELECTRICAL SYSTEM

---

Group 1 Component Location .....	7-1
Group 2 Electrical Circuit .....	7-3
Group 3 Monitoring System .....	7-21
Group 4 Electrical Component Specification .....	7-61
Group 5 Connectors .....	7-68
Group 6 Troubleshooting .....	7-89

# SECTION 7 ELECTRICAL SYSTEM

## GROUP 1 COMPONENT LOCATION

### 1. LOCATION 1

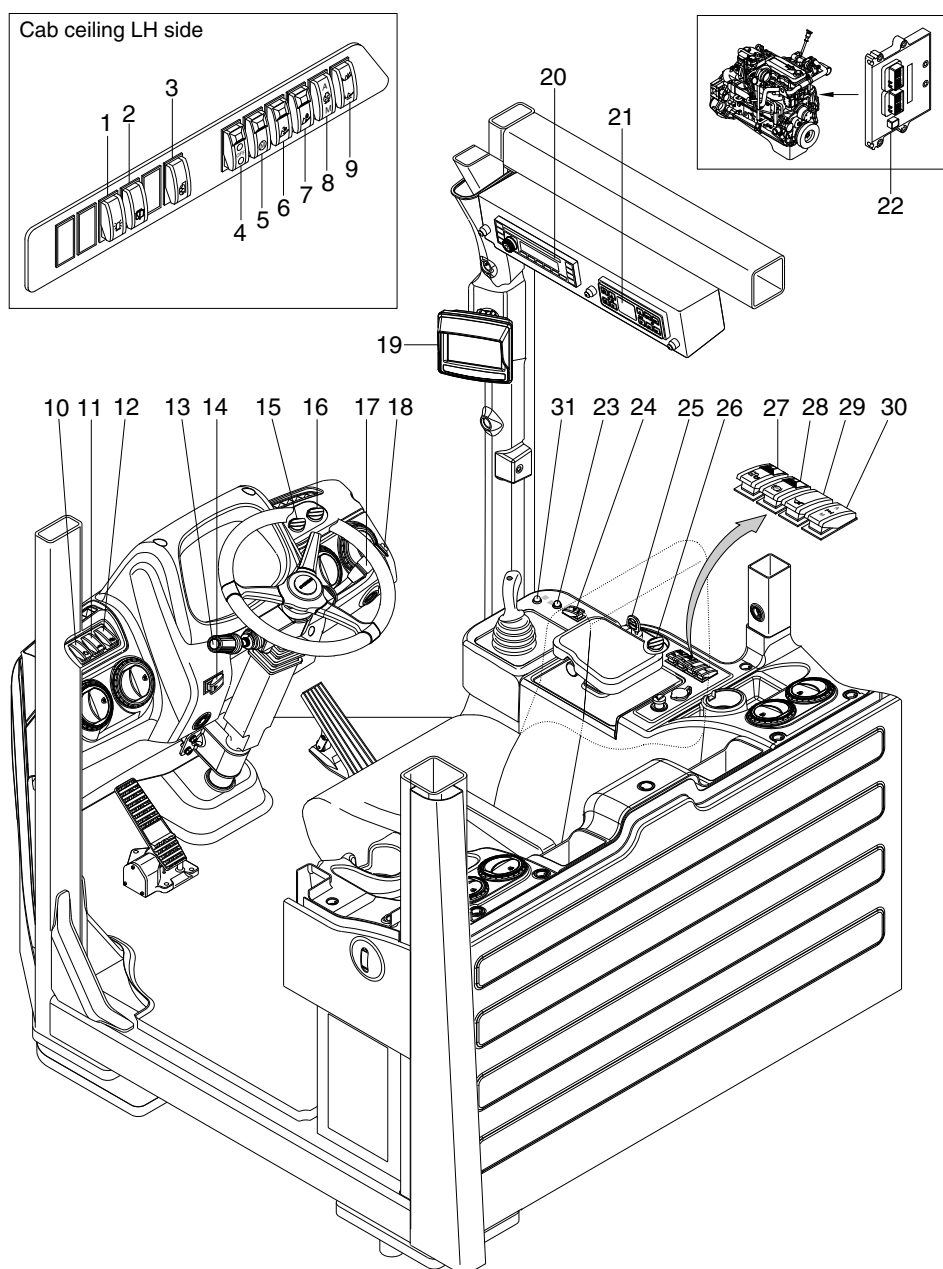

7609AW7EL02

- |  |                               |                                   |
|--|-------------------------------|-----------------------------------|
| 1 Beacon switch (opt)                      | 11 Work lamp switch           | 22 Engine control unit (ECU)      |
| 2 Rear wiper / washer switch               | 12 Lock up switch (opt)       | 23 Work load button               |
| 3 Mirror defrost switch                    | 13 Kick down switch           | 24 Detent enable switch           |
| 4 DPF switch                               | 14 Hazard switch              | 25 Starting switch                |
| 5 Emergency test switch (opt)              | 15 T/M shift mode switch      | Starting button (opt)             |
| 6 Attachment unlock switch (opt)           | 16 Clutch cut off mode switch | 26 Engine mode switch             |
| 7 Attachment lock switch (opt)             | 17 Multi function switch      | 27 Pilot cut off switch           |
| 8 Fan control switch                       | 18 Horn switch                | 28 Parking brake switch           |
| 9 Boom kickout & bucket leveler set switch | 19 Monitor                    | 29 Ride control switch (opt)      |
| 10 Main light switch                       | 20 Radio & USB player         | 30 Differential lock switch (opt) |
|  | 21 Aircon & heater switch     | 31 Store button                   |

## 2. LOCATION 2

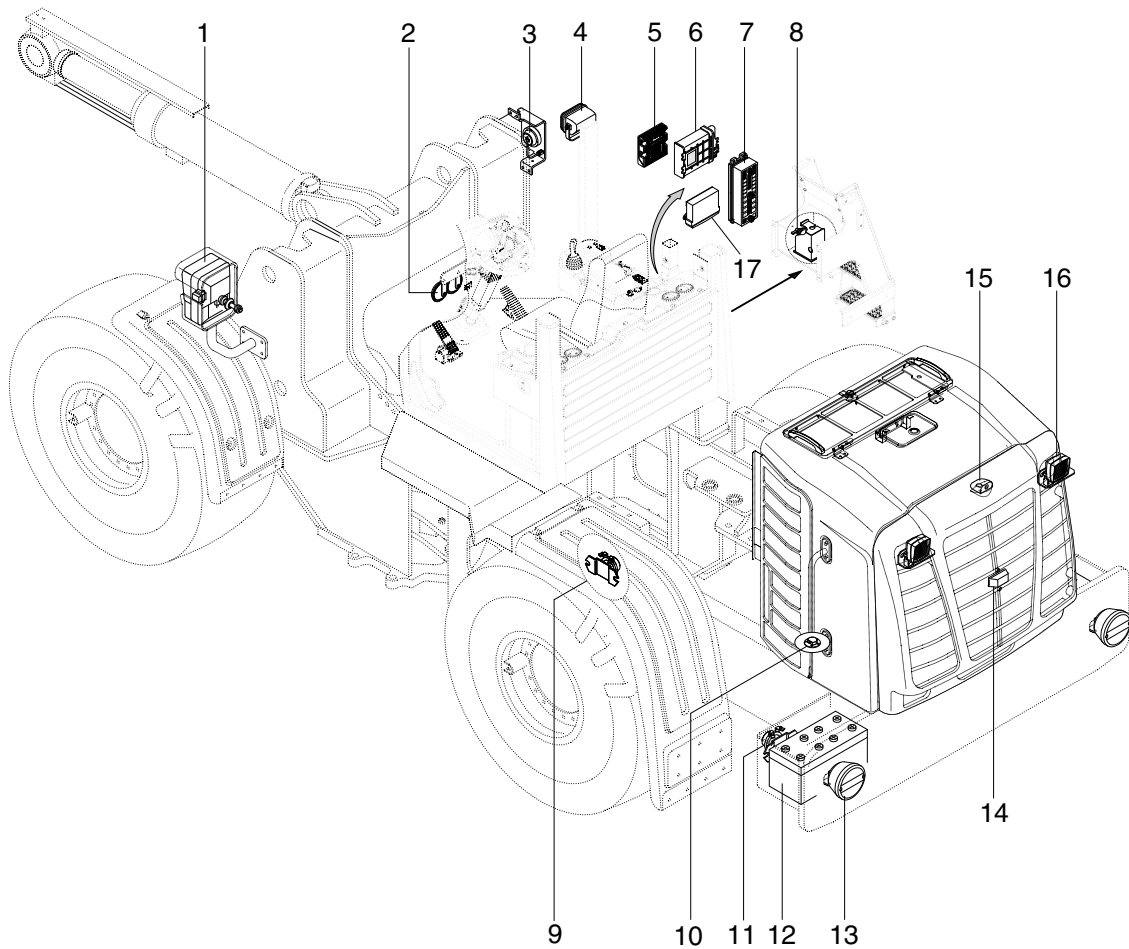

7609A7EL02-1

- |   |                                 |    |                    |    |                                  |
|---|---------------------------------|----|--------------------|----|----------------------------------|
| 1 | Head lamp                       | 7  | Fuse and relay box | 13 | Rear combi lamp                  |
| 2 | Horn                            | 8  | Master switch      | 14 | Camera (opt)                     |
| 3 | Angle sensor                    | 9  | Start relay        | 15 | Work lamp                        |
| 4 | Work lamp                       | 10 | Fuel sender        | 16 | Number plate lamp                |
| 5 | Machine control unit (MCU)      | 11 | Battery relay      | 17 | Steering control unit (SCU), opt |
| 6 | Transmission control unit (TCU) | 12 | Battery            |    |                                  |