

GROUP 2 SPECIFICATION

1. MAJOR COMPONENT (HL760-9, HL760XTD-9)

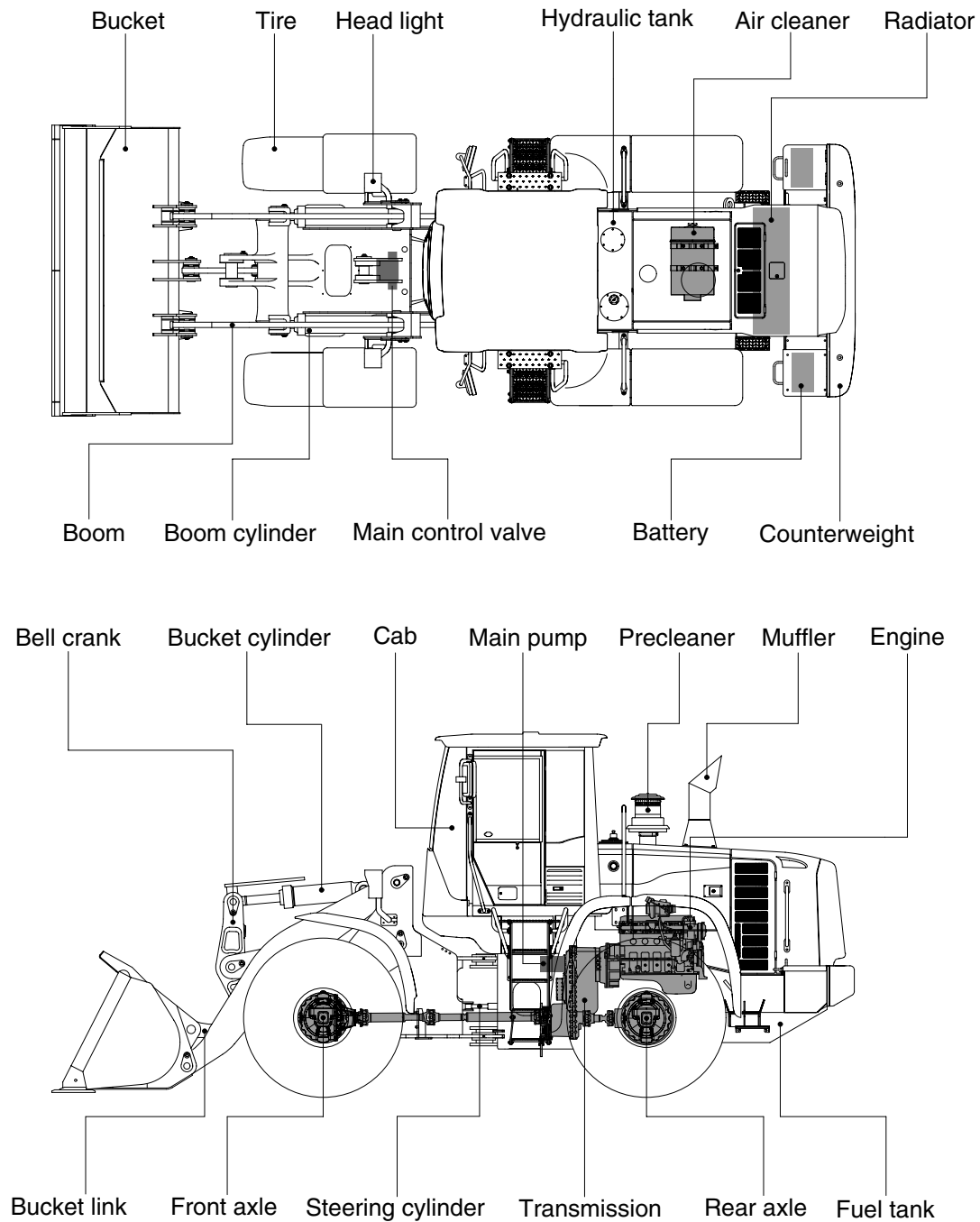

75792SE01

2. SPECIFICATIONS

1) WITH BOLT-ON CUTTING EDGE TYPE BUCKET (HL760-9)

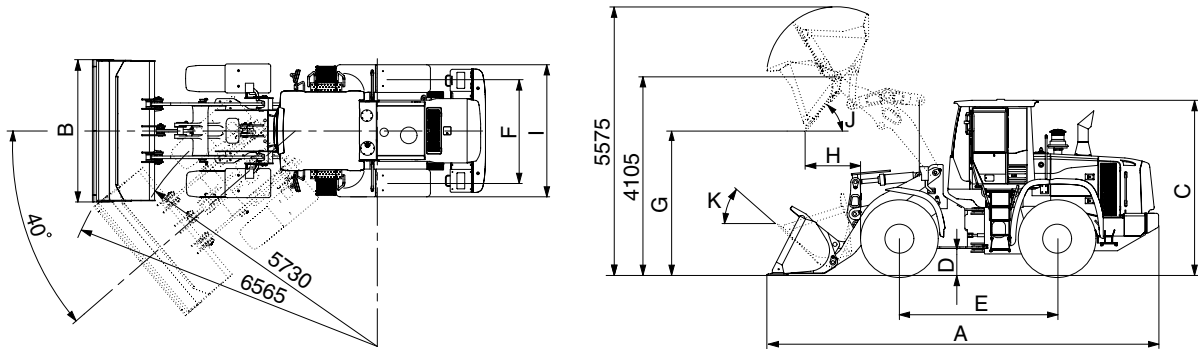

76092SE03

Description		Unit	Specification	
Operating weight		kg (lb)	17900 (39460)	
Bucket capacity	Struck	m ³ (yd ³)	2.8 (3.7)	
	Heaped		3.3 (4.3)	
Overall length	A	mm (ft-in)	8100 (26' 7")	
Overall width	B		2900 (9' 6")	
Overall height	C		3450 (11' 4")	
Ground clearance	D		420 (1' 5")	
Wheelbase	E		3300 (10' 10")	
Tread	F		2160 (7' 1")	
Dump clearance at 45°	G		2970 (9' 9")	
Dump reach (full lift)	H		1220 (4' 0")	
Width over tires	I		2770 (9' 1")	
Dump angle	J		degree (°)	47
Roll back angle (carry position)	K			47
Cycle time	Lift (with load)	sec	5.8	
	Dump (with load)		1.2	
	Lower (empty)		3.1	
Maximum travel speed		km/hr (mph)	38.1 (23.7)	
Braking distance		m (ft-in)	13 (42' 7")	
Minimum turning radius (center of outside tire)			5.73 (18' 9")	
Gradeability		degree (°)	30	
Travel speed	Forward	First gear	6.3 (3.9)	
		Second gear	12.0 (7.5)	
		Third gear	24.0 (15.0)	
		Fourth gear	38.1 (23.7)	
	Reverse	First gear	6.7 (4.2)	
		Second gear	12.6 (7.9)	
Third gear		25.2 (15.7)		

WITH BOLT-ON CUTTING EDGE TYPE BUCKET (HL760XTD-9)

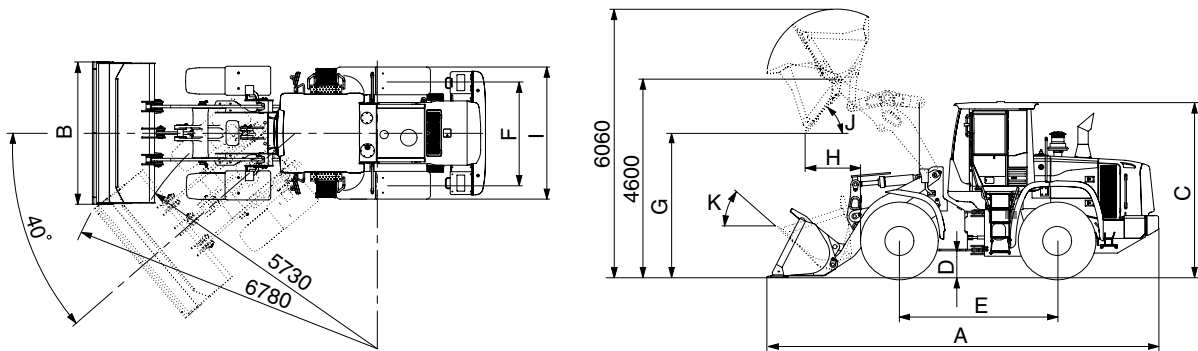

76092SE03-1

Description		Unit	Specification	
Operating weight		kg (lb)	18700 (41230)	
Bucket capacity	Struck	m ³ (yd ³)	2.8 (3.7)	
	Heaped		3.3 (4.3)	
Overall length	A	mm (ft-in)	8660 (28' 5")	
Overall width	B		2900 (9' 6")	
Overall height	C		3450 (11' 4")	
Ground clearance	D		420 (1' 5")	
Wheelbase	E		3300 (10' 10")	
Tread	F		2160 (7' 1")	
Dump clearance at 45°	G		3460 (11' 4")	
Dump reach (full lift)	H		1235 (4' 1")	
Width over tires	I		2770 (9' 1")	
Dump angle	J		degree (°)	47
Roll back angle (carry position)	K			49
Cycle time	Lift (with load)	sec	5.8	
	Dump (with load)		1.2	
	Lower (empty)		3.1	
Maximum travel speed		km/hr (mph)	38.1 (23.7)	
Braking distance		m (ft-in)	13 (42' 7")	
Minimum turning radius (center of outside tire)			5.73 (18' 9")	
Gradeability		degree (°)	30	
Travel speed	Forward	First gear	6.3 (3.9)	
		Second gear	12.0 (7.5)	
		Third gear	24.0 (15.0)	
		Fourth gear	38.1 (23.7)	
	Reverse	First gear	6.7 (4.2)	
		Second gear	12.6 (7.9)	
Third gear		25.2 (15.7)		

2) WITH TOOTH TYPE BUCKET (HL760-9)

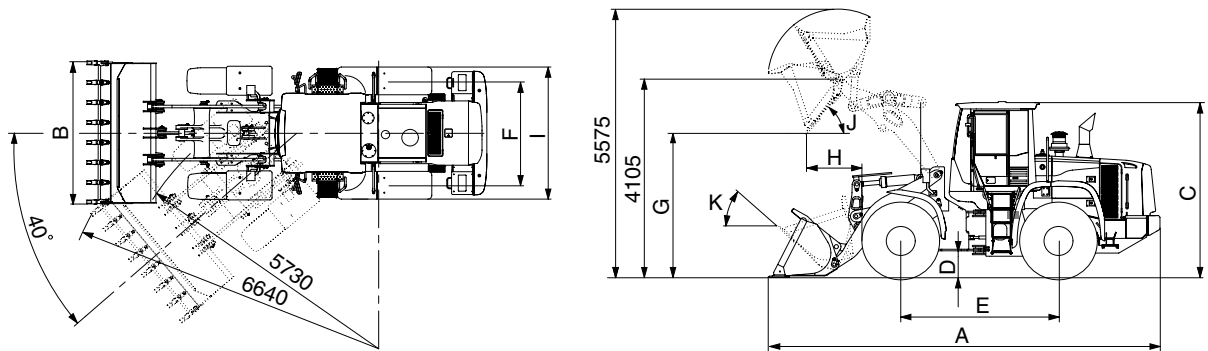

76092SE02

Description		Unit	Specification	
Operating weight		kg (lb)	17900 (39460)	
Bucket capacity	Struck	m ³ (yd ³)	2.7 (3.5)	
	Heaped		3.2 (4.2)	
Overall length	A	mm (ft-in)	8255 (27' 1")	
Overall width	B		2950 (9' 8")	
Overall height	C		3450 (11' 4")	
Ground clearance	D		420 (1' 5")	
Wheelbase	E		3300 (10' 10")	
Tread	F		2160 (7' 1")	
Dump clearance at 45°	G		2845 (9' 4")	
Dump reach (full lift)	H		1305 (4' 3")	
Width over tires	I		2770 (9' 1")	
Dump angle	J		degree (°)	47
Roll back angle (carry position)	K			47
Cycle time	Lift (with load)	sec	5.8	
	Dump (with load)		1.2	
	Lower (empty)		3.1	
Maximum travel speed		km/hr (mph)	38.1 (23.7)	
Braking distance		m (ft-in)	13 (42' 7")	
Minimum turning radius (center of outside tire)			5.73 (18' 9")	
Gradeability		degree (°)	30	
Travel speed	Forward	First gear	6.3 (3.9)	
		Second gear	12.0 (7.5)	
		Third gear	24.0 (15.0)	
		Fourth gear	38.1 (23.7)	
	Reverse	First gear	6.7 (4.2)	
		Second gear	12.6 (7.9)	
Third gear		25.2 (15.7)		

WITH TOOTH TYPE BUCKET (HL760XTD-9)

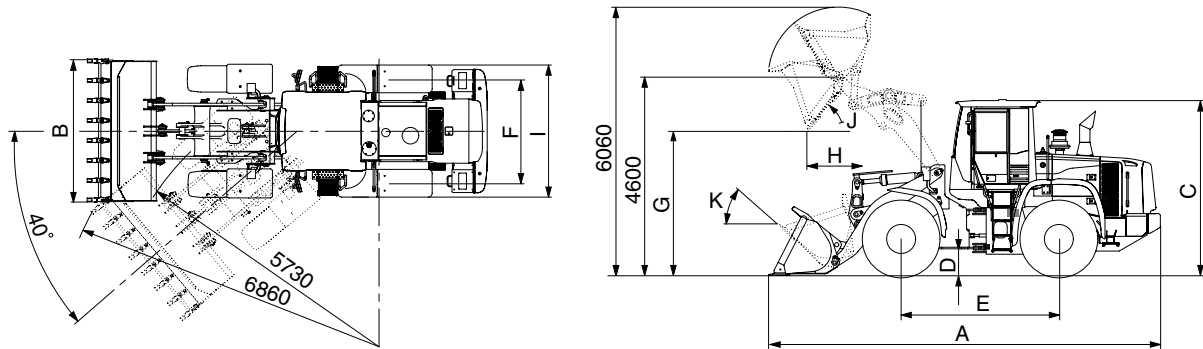

76092SE02-1

Description		Unit	Specification	
Operating weight		kg (lb)	18700 (41320)	
Bucket capacity	Struck	m ³ (yd ³)	2.7 (3.5)	
	Heaped		3.2 (4.2)	
Overall length	A	mm (ft-in)	8820 (28' 11")	
Overall width	B		2950 (9' 8")	
Overall height	C		3450 (11' 4")	
Ground clearance	D		420 (1' 5")	
Wheelbase	E		3300 (10' 10")	
Tread	F		2160 (7' 1")	
Dump clearance at 45°	G		3335 (10' 11")	
Dump reach (full lift)	H		1330 (4' 4")	
Width over tires	I		2770 (9' 1")	
Dump angle	J		degree (°)	47
Roll back angle (carry position)	K			49
Cycle time	Lift (with load)	sec	5.8	
	Dump (with load)		1.2	
	Lower (empty)		3.1	
Maximum travel speed		km/hr (mph)	38.1 (23.7)	
Braking distance		m (ft-in)	13 (42' 7")	
Minimum turning radius (center of outside tire)			5.73 (18' 9")	
Gradeability		degree (°)	30	
Travel speed	Forward	First gear	6.3 (3.9)	
		Second gear	12.0 (7.5)	
		Third gear	24.0 (15.0)	
		Fourth gear	38.1 (23.7)	
	Reverse	First gear	6.7 (4.2)	
		Second gear	12.6 (7.9)	
Third gear		25.2 (15.7)		

3. WEIGHT

Item		kg	lb
Front frame assembly		1652	3640
Rear frame assembly		1998	4410
Front fender (LH & RH)		31	68
Counterweight	HL760-9	1050	2320
	HL760XTD-9	1650	3640
Cab assembly		1050	2320
Engine assembly		485	1070
Transmission assembly		470	1040
Drive shaft (front)		44	97
Drive shaft (center)		46	101
Drive shaft (rear)		27	60
Front axle (include differential)		630	1330
Rear axle (include differential)		632	1390
Tire (23.5-25, 20PR. L3)		300	661
Hydraulic tank assembly		250	550
Fuel tank assembly		362	798
Main pump assembly		55	121
Fan & brake pump assembly		7	15
Main control valve (2/3 spool)		34/41	75/90
Steering valve (EHPS)		15	33
Boom assembly	HL760-9	1200	2646
	HL760XTD-9	1360	3000
Bell crank assembly		360	794
Bucket link		57	126
3.3 m ³ bucket, with bolt on cutting edge		1670	3680
3.2 m ³ bucket, with tooth		1660	3660
Boom cylinder assembly		150	331
Bucket cylinder assembly		172	379
Steering cylinder assembly		25	55
Seat		40	88
Battery		55	121

4. SPECIFICATION FOR MAJOR COMPONENTS

1) ENGINE

Item	Specification
Model	Cummins QSB6.7
Type	4-cycle turbocharged, charge air cooled diesel engine
Control type	Electronic control
Cooling method	Water cooling
Number of cylinders and arrangement	6 cylinders, in-line
Firing order	1-5-3-6-2-4
Combustion chamber type	Direct injection type
Cylinder bore × stroke	107 × 124 mm (4.2" × 4.9")
Piston displacement	6730 cc (410cu in)
Compression ratio	17.2 : 1
Rated horse power (Net)	205 hp at 2100 rpm
Maximum torque at 1500 rpm (Net)	97 kgf · m (702 lbf · ft)
Engine oil quantity	18 l (4.8 U.S. gal)
Wet weight	485 kg (1062 lb)
High idling speed	2230 ± 50 rpm
Low idling speed	800 ± 25 rpm
Rated fuel consumption (at rated)	234 g/kW · hr
Starting motor	Nippondenso 228000-7902 (24V-3.7kW)
Alternator	Delco Remy 24SI (24V-70Amp)
Battery	2 × 12V × 130Ah

2) MAIN PUMP

Item	Specification	
	Steering	Loader
Type	Variable piston pump	
Capacity	60 cc/rev	51 cc/rev
Maximum operating pressure	280 kgf/cm ² (3980 psi)	
Rated oil quantity	126 l /min (33.3 U.S.gpm)	107 l /min (28.3 U.S.gpm)
Rated speed	2100 rpm	

3) FAN + BRAKE PUMP

Item	Specification	
	Fan	Brake
Type	Fixed displacement tandem gear pump	
Capacity	19.0 cc/rev	11.9 cc/rev
Maximum operating pressure	120 kgf/cm ² (1710 psi)	150 kgf/cm ² (2130 psi)
Rated oil quantity	43 l /min (10.8 U.S.gpm)	27 l /min (6.6 U.S.gpm)
Rated speed	2100 rpm	

4) MAIN CONTROL VALVE

Item	Specification
Type	2 spool
Operating method	Hydraulic pilot assist
System pressure	280 kgf/cm ² (3980 psi)
Overload relief valve pressure	340 kgf/cm ² (4840 psi) / *300 kgf/cm ² (4270 psi)

* : Bucket dump

5) REMOTE CONTROL VALVE

Item	Specification	
Type	Pressure reducing type	
Operating pressure	Minimum	6.5 kgf/cm ² (92.4 psi)
	Maximum	22 kgf/cm ² (312.9 psi)
Single operation stroke	Lever	80 mm (3.4 in)

6) CYLINDER

Item		Specification
Boom cylinder	Bore dia × Rod dia × Stroke	∅ 140 × ∅ 80 × 757 mm
Bucket cylinder	Bore dia × Rod dia × Stroke	∅ 160 × ∅ 85 × 530 mm
Steering cylinder	Bore dia × Rod dia × Stroke	∅ 75 × ∅ 45 × 424 mm

7) DYNAMIC POWER TRANSMISSION DEVICES

Item		Specification	
Transmission	Model	ZF4WG 210	
	Type	Converter	Single-stage, single-phase
		Transmission	Full-automatic power shift
	Converter stall ratio	2.121 : 1	
	Gear shift	Forward fourth gear, reverse third gear	
	Control	Electrical single lever type, kick-down system	
	Pump rated flow	105 ℓ /min (27.7 U.S.gpm) at 2000 rpm	
Axle	Drive devices	4-wheel drive	
	Front	Front fixed location	
	Rear	Oscillation ± 12° of center pin-loaded	
Wheels	Tires	23.5-25, 20PR (L3)	
Brakes	Travel	Four-wheel, wet-disc type, full hydraulic	
	Parking	Spring applied, hydraulic released brake on transmission	
Steering	Type	Full hydraulic, articulated	
	Steering angle	40° to both right and left angle, respectively	

5. TIGHTENING TORQUE OF MAJOR COMPONENT

No.	Descriptions	Bolt size	Torque		
			kgf · m	lbf · ft	
1	Engine	Engine mounting bolt, nut (rubber, 2EA)	M20×2.5	57.9 ± 8.7	419 ± 63
2		Engine mounting bolt (bracket, 8EA)	M12×1.75	10.7 ± 1.6	77.4 ± 11.6
3		Engine mounting bolt (T/C housing, 12EA)	M10×1.5	4.6 ± 0.9	33.3 ± 6.5
4		Engine mounting bolt (flywheel, 4EA)	M10×1.5	4.5 ± 0.6	32.5 ± 4.3
5		Radiator mounting bolt	M16×2.0	29.7 ± 4.5	215 ± 32.5
6		Fuel tank mounting bolt, nut	M16×2.0	29.7 ± 4.5	215 ± 32.5
7	Hydraulic system	Main pump housing mounting bolt	M16×2.0	29.7 ± 4.5	215 ± 32.5
8		Fan & Brake pump housing mounting bolt	M10×1.5	6.9 ± 1.4	50 ± 10.1
9		Main control valve mounting bolt	M12×1.75	12.8 ± 3.0	92.6 ± 21.7
10		Steering unit mounting bolt	M10×1.5	6.9 ± 1.4	50 ± 10.1
11		Stop valve	M10×1.5	6.9 ± 1.4	50 ± 10.1
12		Steering valve (EHPS) mounting bolt	M8×1.25	2.5 ± 0.5	18.1 ± 3.6
13		Cushion valve	M8×1.25	2.5 ± 0.5	18.1 ± 3.6
14		Brake valve mounting bolt	M8×1.25	2.5 ± 0.5	18.1 ± 3.6
15		Cut-off valve mounting bolt	M12×1.75	12.8 ± 3.0	92.6 ± 21.7
16		Remote control lever mounting bolt	M6×1.0	1.1 ± 0.2	8.0 ± 1.4
17		Safety valve	M10×1.5	6.9 ± 1.4	50 ± 10.1
18		Hydraulic oil tank mounting bolt	M16×2.0	29.7 ± 4.5	215 ± 32.5
19	Power train system	Transmission mounting bolt, nut (rubber, 2EA)	M24×3.0	100 ± 15	723 ± 108
20		Transmission mounting bolt (bracket, 6EA)	M20×2.5	46.3 ± 7.0	335 ± 50.6
21		Front axle mounting bolt, nut	M27×2.0	135 ± 15	976 ± 108
22		Rear axle support mounting bolt, nut	M36×3.0	308 ± 46.2	2227 ± 334
23		Tire mounting nut	M22×1.5	79 ± 2.5	571 ± 18.1
24		Drive shaft joint mounting bolt	1/2-20UNF	15 ± 2.0	108 ± 14.5
25	Others	Counterweight mounting bolt	M30×3.5	199 ± 30	1439 ± 216
26		Additional counterweight mounting bolt	M24×3.0	100 ± 15	723 ± 108
27		Operator's seat mounting bolt	M8×1.25	3.4 ± 0.8	24.6 ± 5
28		ROPS Cab mounting bolt (4EA)	M20×2.5	58 ± 8.7	419 ± 63

6. TORQUE CHART

Use following table for unspecified torque.

1) BOLT AND NUT

(1) Coarse thread

Bolt size	8T		10T	
	kg · m	lb · ft	kg · m	lb · ft
M 6 × 1.0	0.85 ~ 1.25	6.15 ~ 9.04	1.14 ~ 1.74	8.2 ~ 12.6
M 8 × 1.25	2.0 ~ 3.0	14.5 ~ 21.7	2.73 ~ 4.12	19.5 ~ 29.8
M10 × 1.5	4.0 ~ 6.0	28.9 ~ 43.4	5.5 ~ 8.3	39.8 ~ 60
M12 × 1.75	7.4 ~ 11.2	53.5 ~ 79.5	9.8 ~ 15.8	71 ~ 114
M14 × 2.0	12.2 ~ 16.6	88.2 ~ 120	16.7 ~ 22.5	121 ~ 167
M16 × 2.0	18.6 ~ 25.2	135 ~ 182	25.2 ~ 34.2	182 ~ 247
M18 × 2.5	25.8 ~ 35.0	187 ~ 253	35.1 ~ 47.5	254 ~ 343
M20 × 2.5	36.2 ~ 49.0	262 ~ 354	49.2 ~ 66.6	356 ~ 482
M22 × 2.5	48.3 ~ 63.3	350 ~ 457	65.8 ~ 98.0	476 ~ 709
M24 × 3.0	62.5 ~ 84.5	452 ~ 611	85.0 ~ 115	615 ~ 832
M30 × 3.0	124 ~ 168	898 ~ 1214	169 ~ 229	1223 ~ 1655
M36 × 4.0	174 ~ 236	1261 ~ 1703	250 ~ 310	1808 ~ 2242

(2) Fine thread

Bolt size	8T		10T	
	kg · m	lb · ft	kg · m	lb · ft
M 8 × 1.0	2.17 ~ 3.37	15.7 ~ 24.3	3.04 ~ 4.44	22.0 ~ 32.0
M10 × 1.25	4.46 ~ 6.66	32.3 ~ 48.2	5.93 ~ 8.93	42.9 ~ 64.6
M12 × 1.25	7.78 ~ 11.58	76.3 ~ 83.7	10.6 ~ 16.0	76.6 ~ 115
M14 × 1.5	13.3 ~ 18.1	96.2 ~ 130	17.9 ~ 24.1	130 ~ 174
M16 × 1.5	19.9 ~ 26.9	144 ~ 194	26.6 ~ 36.0	193 ~ 260
M18 × 1.5	28.6 ~ 43.6	207 ~ 315	38.4 ~ 52.0	278 ~ 376
M20 × 1.5	40.0 ~ 54.0	289 ~ 390	53.4 ~ 72.2	386 ~ 522
M22 × 1.5	52.7 ~ 71.3	381 ~ 515	70.7 ~ 95.7	512 ~ 692
M24 × 2.0	67.9 ~ 91.9	491 ~ 664	90.9 ~ 123	658 ~ 890
M30 × 2.0	137 ~ 185	990 ~ 1338	182 ~ 248	1314 ~ 1795
M36 × 3.0	192 ~ 260	1389 ~ 1879	262 ~ 354	1893 ~ 2561

2) PIPE AND HOSE (FLARE type)

Thread size	Width across flat (mm)	kgf · m	lbf · ft
1/4"	19	4	28.9
3/8"	22	5	36.2
1/2"	27	9.5	68.7
3/4"	36	18	130
1"	41	21	152
1-1/4"	50	35	253

3) PIPE AND HOSE (ORFS type)

Thread size	Width across flat (mm)	kgf · m	lbf · ft
9/16-18	19	4	28.9
11/16-16	22	5	36.2
13/16-16	27	9.5	68.7
1-3/16-12	36	18	130
1-7/16-12	41	21	152
1-11/16-12	50	35	253

4) FITTING

Thread size	Width across flat (mm)	kgf · m	lbf · ft
1/4"	19	4	28.9
3/8"	22	5	36.2
1/2"	27	9.5	68.7
3/4"	36	18	130
1"	41	21	152
1-1/4"	50	35	253

7. RECOMMENDED LUBRICANTS

Use only oils listed below or equivalent.

Do not mix different brand oil.

Service point	Kind of fluid	Capacity l (U.S. gal)	Ambient temperature °C (°F)								
			-20 (-4)	-10 (14)	0 (32)	10 (50)	20 (68)	30 (86)	40 (104)		
Engine oil pan	Engine oil	18 (4.8)				SAE 30					
			SAE 10W								
			SAE 10W-30								
			SAE 15W-40								
Transmission	Engine oil	32 (8.5)	SAE 10W-30								
			SAE 15W-40								
Axle	UTTO	Front : 38 (10.0) Rear : 31 (8.2)	*Refer to below list								
Hydraulic tank	Hydraulic oil	Tank: 178 (47) System: 252 (66.6)	ISO VG 32								
			ISO VG 46								
			ISO VG 68								
Fuel tank	Diesel fuel	334 (88.2)	ASTM D975 NO.1								
			ASTM D975 NO.2								
Fitting (grease nipple)	Grease	As required	NLGI NO.1								
			NLGI NO.2								
Radiator	Mixture of antifreeze and water 50 : 50	39 (10.3)	Ethylene glycol base permanent type								

- SAE : Society of Automotive Engineers
- API : American Petroleum Institute
- ISO : International Organization for Standardization
- NLGI : National Lubricating Grease Institute
- ASTM : American Society of Testing and Material
- UTTO : Universal Tractor Transmission Oil

- ★ Recommended oil list
- BP TERRAC SUPER TRANSMISSION 10W-30
- CASTROL AGRI TRANS PLUS 10W-30
- MOBILFLUID 426
- SHELL DONAX TD 10W-30
- TOTAL DYNATRANS MPV