

GROUP 4 DISASSEMBLY AND ASSEMBLY

1. CONTROL VALVE

1) DISASSEMBLY

- (1) Illustration on the right shows the complete control unit.

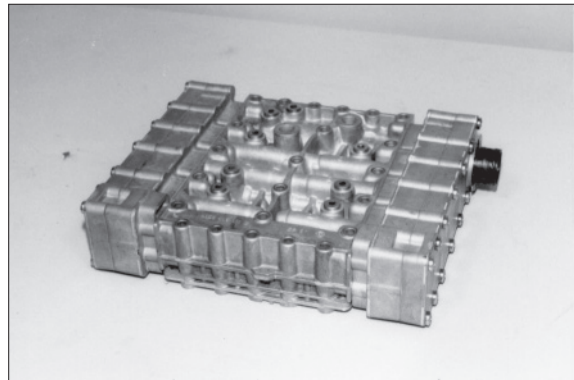

73073CV001

- (2) Mark the installation position of the different covers, the housing and cable harness with the valve housing.

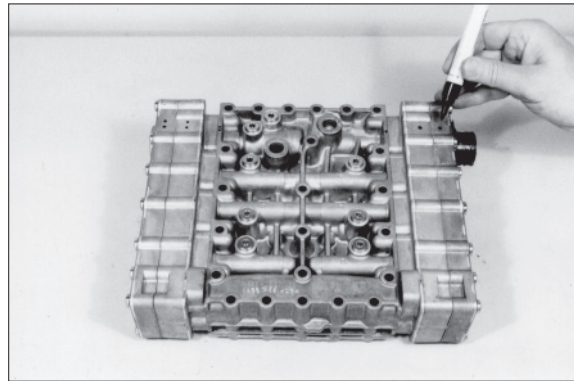

73073CV002

- (3) Loosen socket head screws.
Separate duct plate, 1st gasket, intermediate plate and 2nd gasket from the valve housing.
Box spanner 5873 042 002

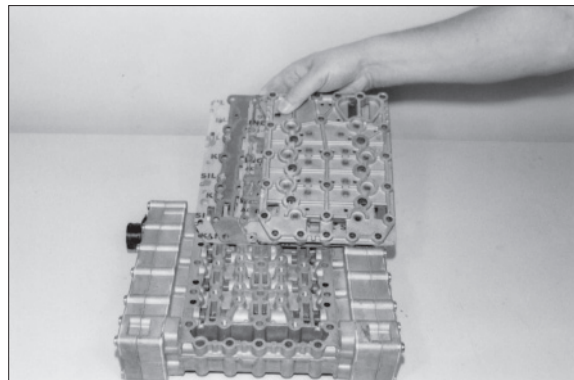

73073CV003

- (4) Remove retaining clip.

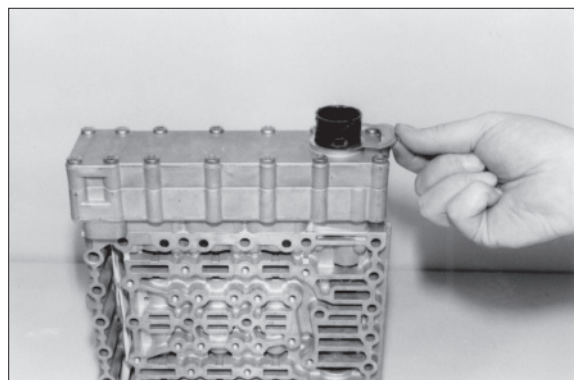

73073CV004

- (5) Loosen socket head screws.
Separate cover from housing and cable harness.
Box spanner 5873 042 002

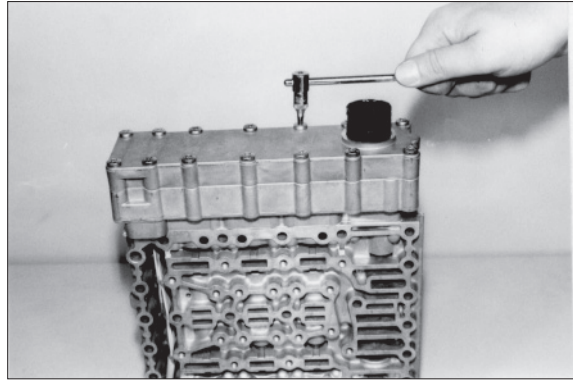

73073CV005

- (6) Disassemble opposite cover.
Disconnect pressure regulator and remove cable harness.

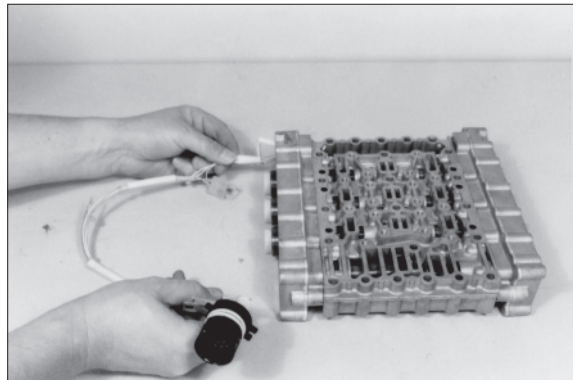

73073CV006

- (7) Loosen socket head screws, remove fixing plate and pressure regulators (3EA).
Box spanner 5873 042 002

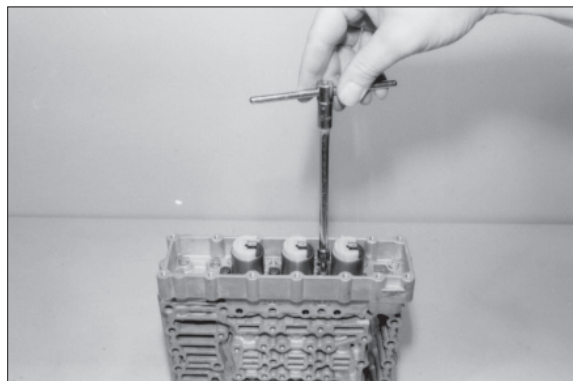

73073CV007

- (8) Loosen two socket head screws and locate housing provisionally, using adjusting screws (housing is under spring preload).
Now, loosen remaining socket head screws.
Box spanner 5873 042 002
Adjusting screws 5870 204 036

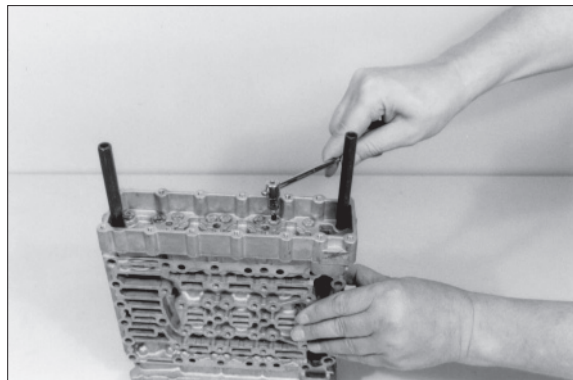

73073CV008

- (9) Separate housing from valve housing by loosening the adjusting screws uniformly.
Adjusting screws 5870 204 036

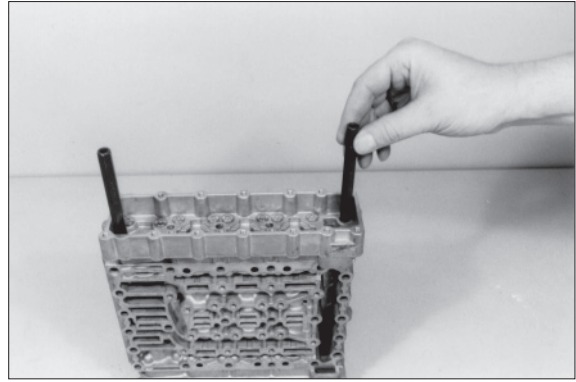

73073CV009

- (10) Remove components.

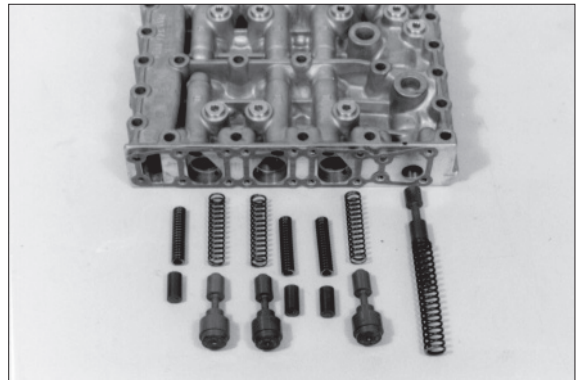

73073CV010

- (11) Remove opposite pressure regulators, housing as well as components accordingly.

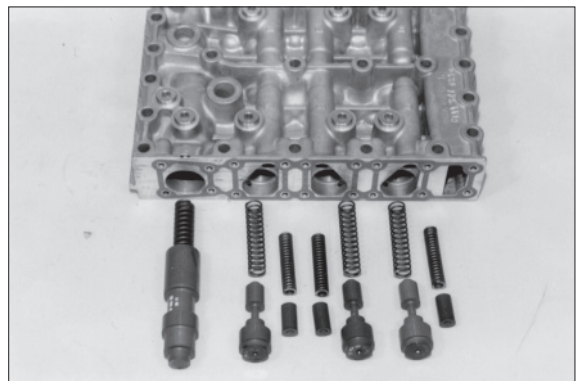

73073CV011

2) ASSEMBLY

- ※ Check all components for damage and renew if necessary.
Prior to the installation, check free travel of all moving parts in the housing.
Spools can be exchanged individually.
Oil the components prior to the assembly.
Insert diaphragms with the concave side showing upward until contact is obtained.
- ※ Installation position, see arrows.

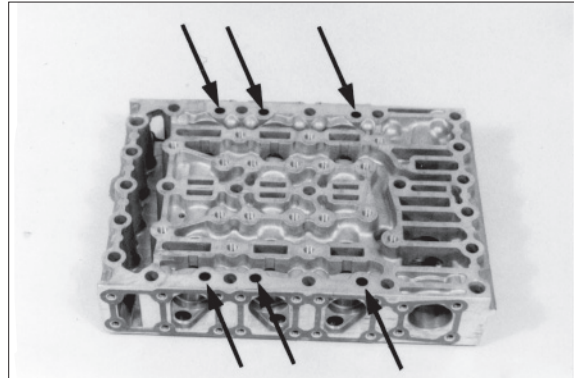

73073CV015

(1) Illustration on the right shows the following components.

- 1 Vibration damper
- 2 Follow-on slide
- 3 Pressure reducing valve

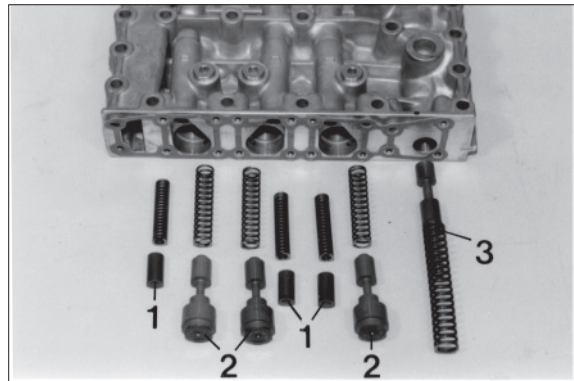

73073CV016

(2) Install components according to figure (1).

- ※ Preload compression spring of the follow-on slides and locate spool provisionally by means of cylindrical pins $\varnothing 5.0$ mm (assembly aid), see arrows.

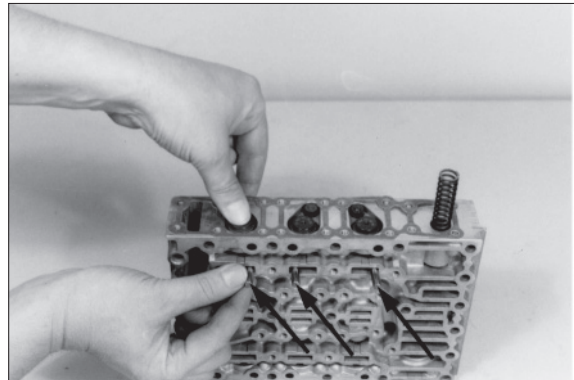

73073CV017

(3) Install two adjusting screws.

Assemble gasket (arrow 1) and housing cover. Now, position the housing cover uniformly, using adjusting screws, until contact is obtained and remove cylindrical pins (assembly aid) again (see the next figure).

- ※ Pay attention to the different housing covers.
Install recess $\varnothing 15$ mm (arrow 2), facing the spring of the pressure reducing valve.
Adjusting screws 5870 204 036

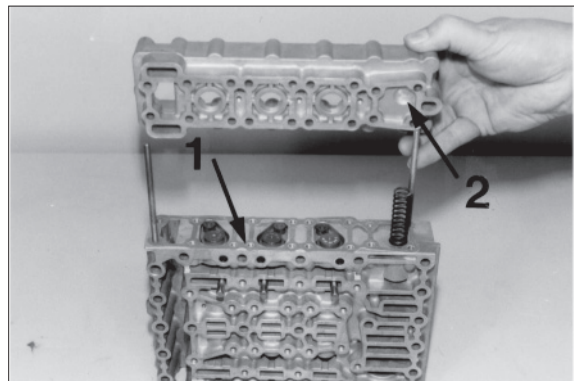

73073CV018

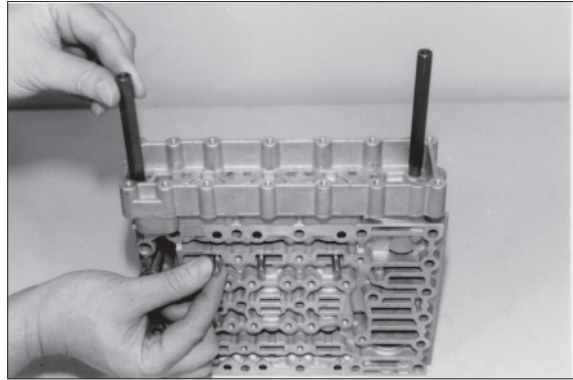

73073CV019

- (4) Fasten housing cover by means of socket head screws.
 · Torque limit : 0.56 kgf · m (4.06 lbf · ft)
 Box spanner 5873 042 002

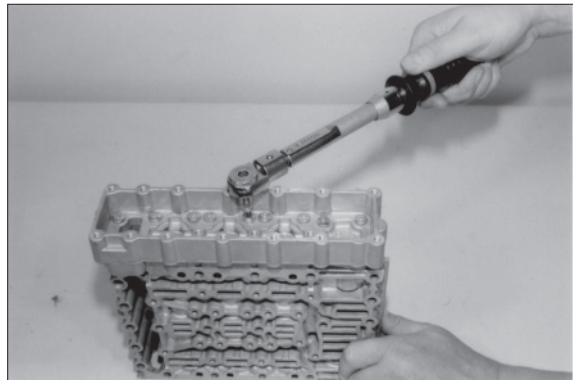

73073CV020

- (5) Introduce pressure regulators and fix by means of fixing plates and socket head screws.
 ※ Install fixing plate, with the claw showing downward.
 Pay attention to the radial installation position of the pressure regulators, see figure.
 · Torque limit : 0.56 kgf · m (4.06 lbf · ft)
 Box spanner 5873 042 002

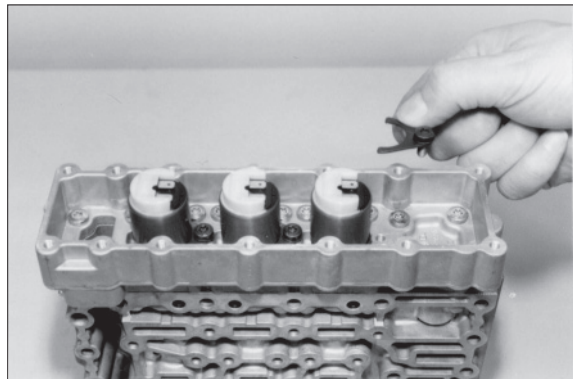

73073CV021

Pre assemble opposite side

- (6) Illustration on the right shows the following components.
 1 Main pressure valve
 2 Follow on slide
 3 Vibration damper

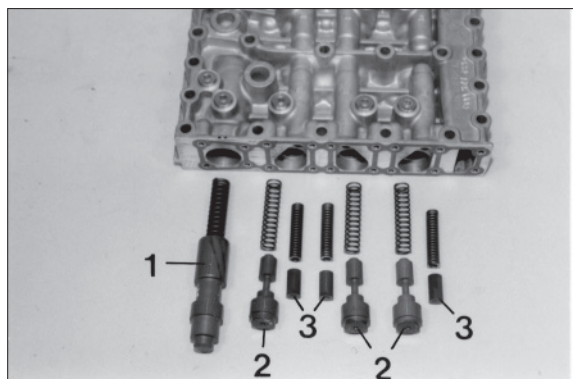

73073CV022

- (7) Install components according to figure (6).
Preload compression springs of the follow-on slides and locate spool provisionally by means of cylindrical pins $\varnothing 5.0$ mm (assembly aid), see arrows.
Install two adjusting screws.

Assemble gasket (arrow 1) and housing cover, and position them uniformly against shoulder, using adjusting screws.

- ※ Pay attention to the different housing covers-install the recess $\varnothing 19$ mm (arrow 2), facing the main pressure valve.
Now, fasten housing cover by means of socket head screws.

- Torque limit : 0.56 kgf · m (4.06 lbf · ft)

Remove cylindrical pins (assembly aid) again.

Adjusting screws 5870 204 036

Box spanner 5873 042 002

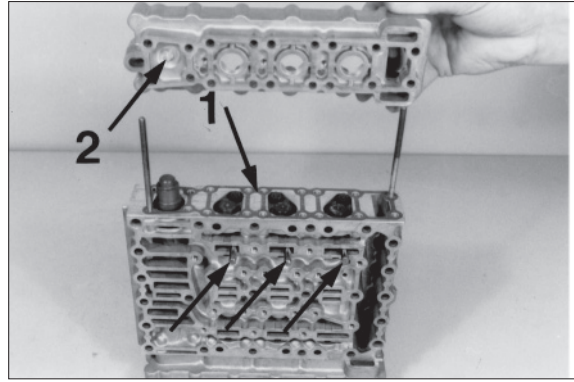

73073CV023

- (8) Introduce pressure regulators and fix by means of fixing plates and socket head screws.

- ※ Install fixing plates, with the claw showing downward.

Pay attention to the radial installation position of the pressure regulators, see figure.

- Torque limit : 0.56 kgf · m (4.06 lbf · ft)

Box spanner 5873 042 002

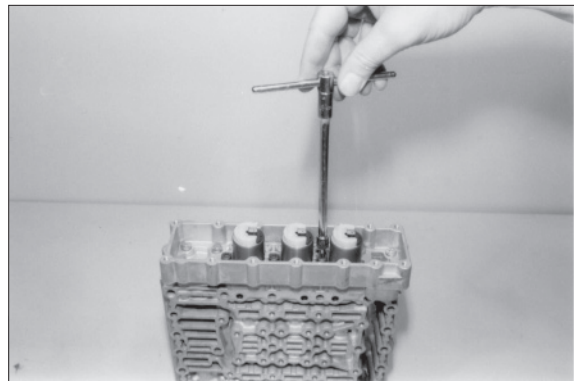

73073CV024

- (9) Introduce cable harness and connect pressure regulators (6EA).

- ※ Pay attention to the installation position of the cable harness, also markings (see figure (2), page 3-71).

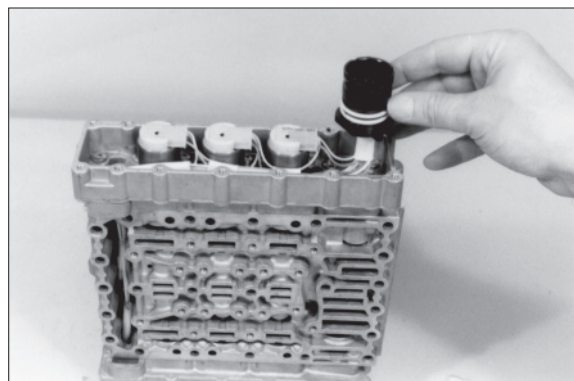

73073CV025

(10) Introduce female connector against shoulder, with the groove facing the guide nose of the cover.

Install gasket (arrow) and fasten cover by means of socket head screws.

· Torque limit : 0.56 kgf · m (4.06 lbf · ft)

Box spanner 5873 042 002

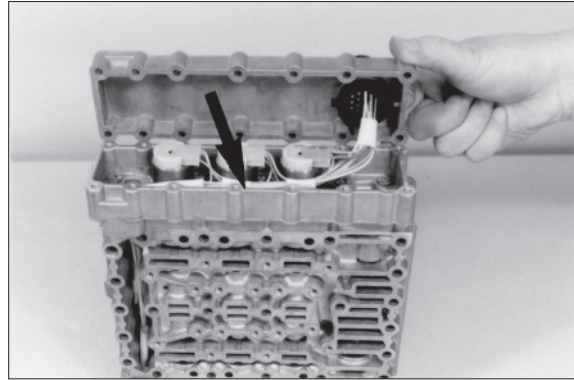

73073CV026

(11) Fix female connector by means of retaining clamp, see figure.

Install opposite cover.

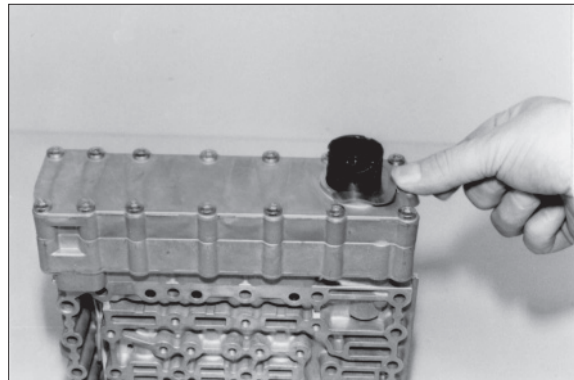

73073CV027

(12) Install two adjusting screws and mount gasket I.

※ Pay attention to the different gaskets, see on the right figure and (15).

Adjusting screws 5870 204 063

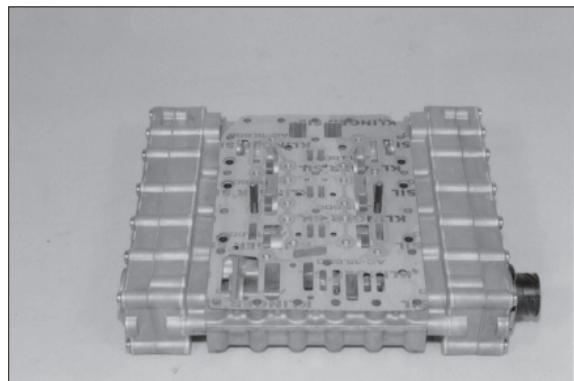

73073CV028

Intermediate plate-Version with screens

(13) Insert screws (6EA) flush mounted into the bore of the intermediate plate, see arrow.

※ Pay attention to the installation position-screws are showing upward (facing the duct plate).

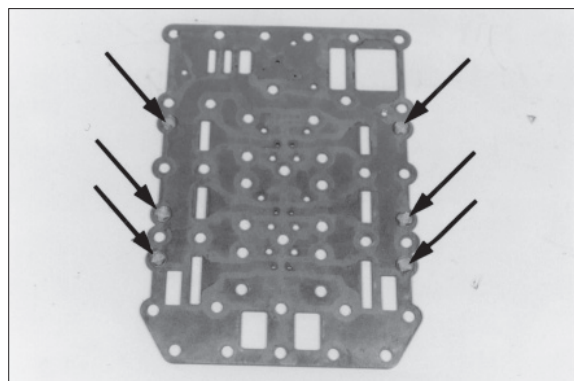

73073CV029

(14) Mount intermediate plate, with the screens showing upward.

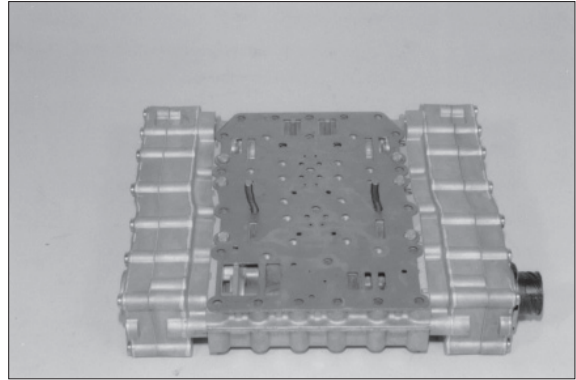

73073CV030

(15) Mount gasket II.

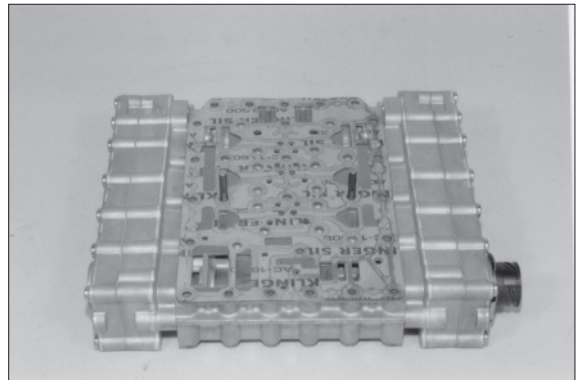

73073CV031

(16) Mount duct plate and fasten it uniformly by means of socket head screws.

· Torque limit : 0.97 kgf · m (7.0 lbf · ft)

Box spanner 5873 042 002

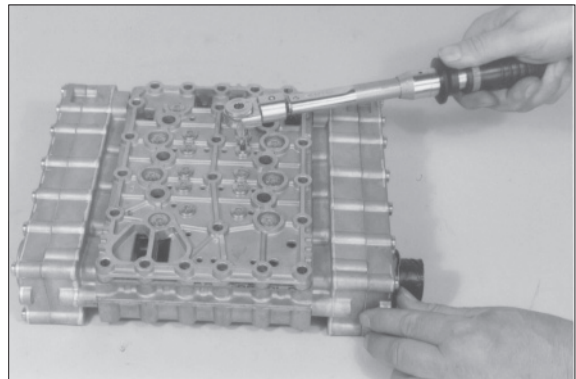

73073CV032

(17) Equip screw plug (8EA) with new O-rings and install them.

· Torque limit : 0.56 kgf · m (4.06 lbf · ft)

※ The installation of the hydraulic control unit is described, starting from page 3-128.

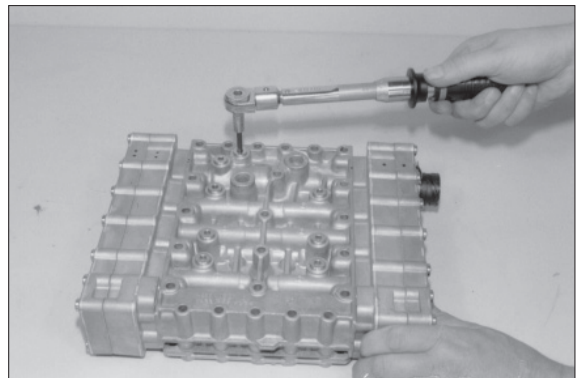

73073CV033

2. POWERSHIFT TRANSMISSION

Fasten transmission of the assembly car.

Assembly car 5870 350 000

Strips 5870 350 063

Support 5870 350 090

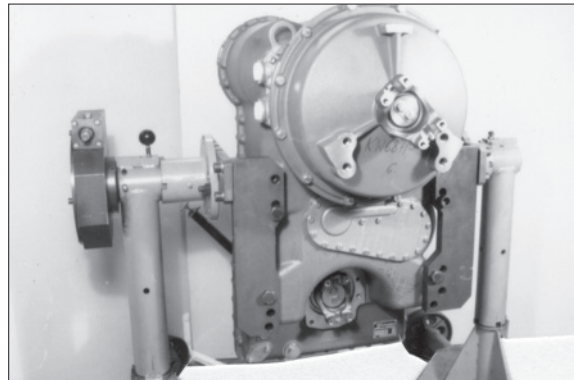

75773TM050

1) DISASSEMBLY

(1) Separate hydraulic control unit and duct plate from gearbox housing

① Loosen two socket head screws and install adjusting screws.

Now, loosen remaining socket head screws and separate valve housing from duct plate.

Adjusting screws (M6) 5870 204 063

Box spanner 5873 042 002

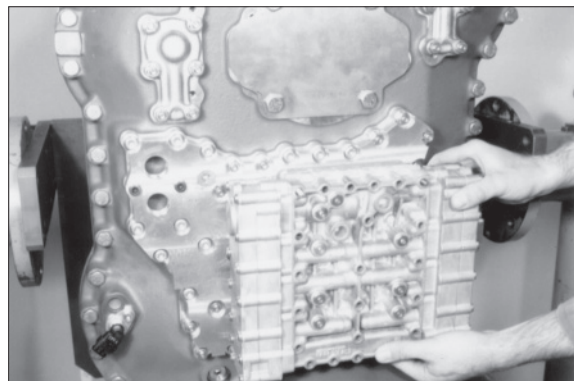

75773TM051

② Remove both gaskets and intermediate plate.

Loosen socket head screws as well as hexagon nuts and separate duct plate from gearbox housing.

Now, remove gasket.

Box spanner 5873 042 004

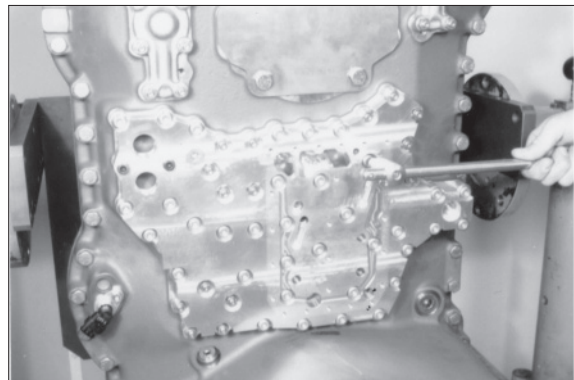

75773TM052

③ Pull converter safety valve out of the housing bore.

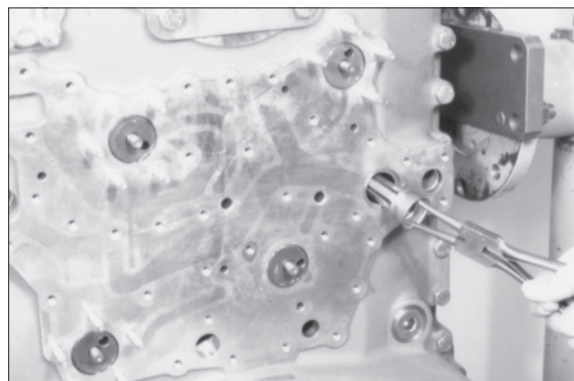

75773TM053

(2) Converter

- ① Loosen hexagon head screws and separate diaphragm from the converter.

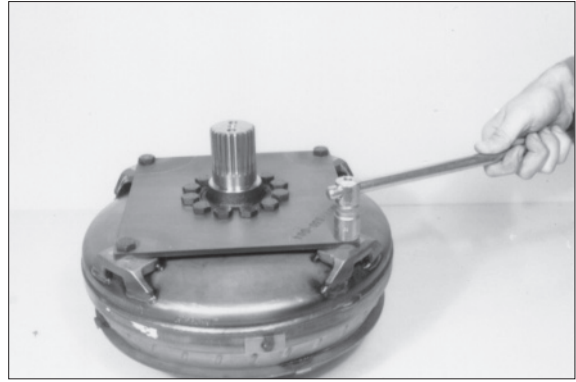

75773TM060

- ② Loosen hexagon head screws and separate drive shaft from the diaphragm.

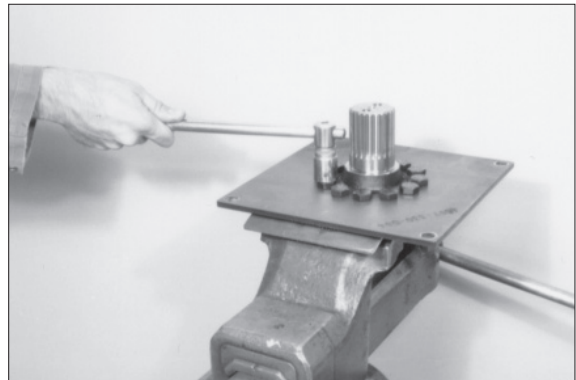

75773TM061

- ③ Remove inductive transmitter (engine).

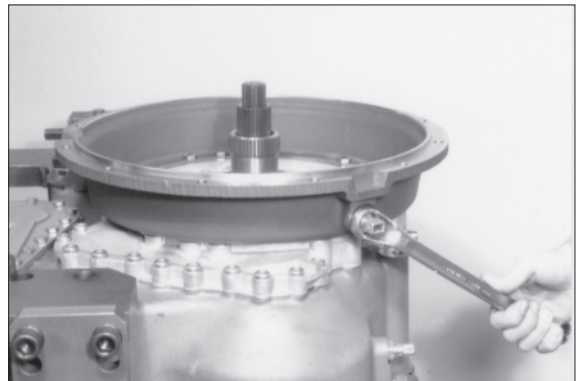

75773TM062

- ④ Loosen hexagon head screws and remove converter bell.

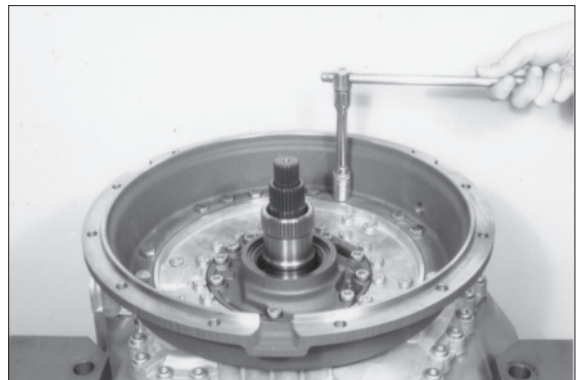

75773TM063

(3) Hydraulic pump

- ① Loosen socket head screws.

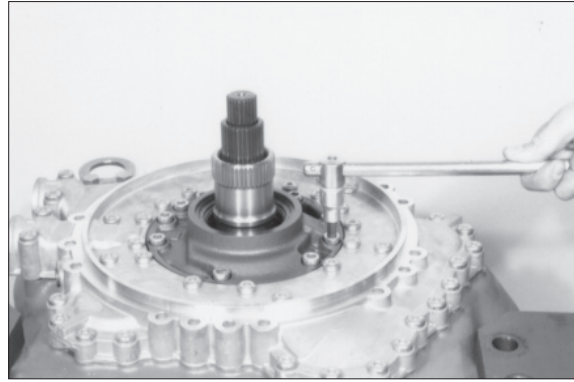

75773TM064

- ② Apply separating device on the gear teeth runout of the stator shaft and pull pump (compl.) by means of two leg puller carefully out of the housing bores.

Separating device 5870 300 024

Two leg puller 5870 970 004



75773TM065

- ③ Separate hydraulic pump from stator shaft.

Separate control disk from pump.

- ※ If traces due to running in should be encountered in the pump housing or on the control disk, the complete pump has to be renewed.

Now, lay on control disk again and fix it by means of grooved pins (2EA).

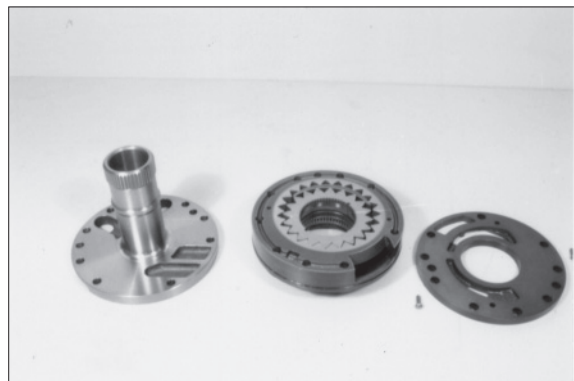

75773TM066

- ④ Loosen socket head screws as well as two hexagon head screws and remove oil feed housing.

Now, remove gasket.

Box spanner 5873 024 004

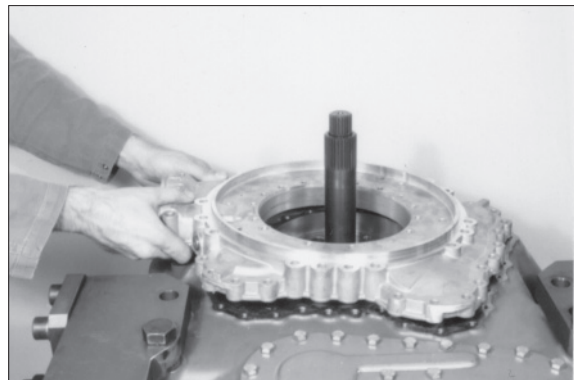

75773TM067

(4) Converter back pressure valve

- ① Preload compression spring and remove lock plate.
Remove released components.

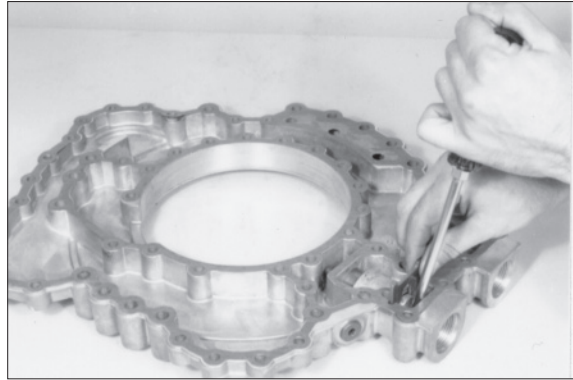

75773TM068

- ② Loosen hexagon head screws.
Remove cover and gasket.

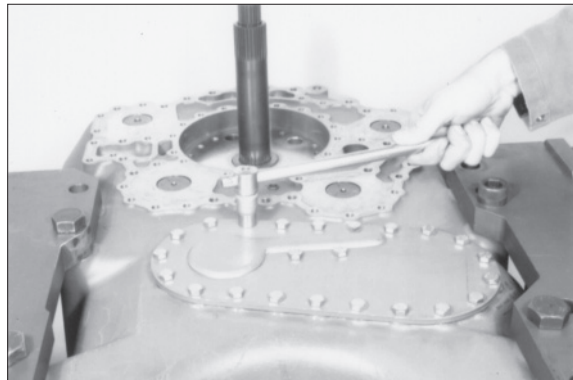

75773TM069

(5) Remove output, input and clutches

- ① Remove lock plate, loosen hexagon head screws and pry converter side output flange off the shaft.
Now, pry shaft seal out of the housing bore.
Tilt transmission 180° and remove rear side output flange accordingly.
Pry bar 5870 345 065

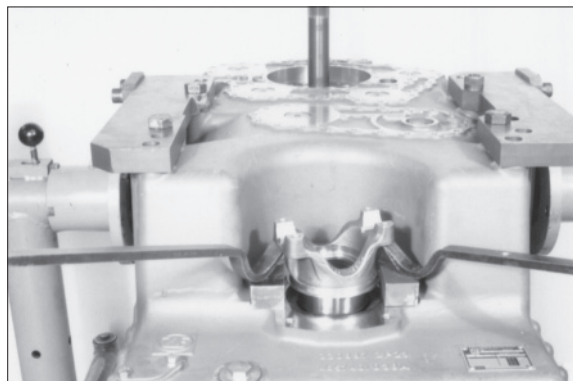

75773TM075

- ② Remove speed sensor as well as both inductive transmitters (arrows).

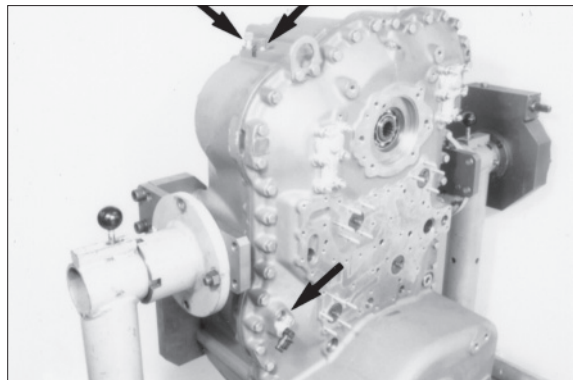

75773TM076

- ③ Loosen hexagon nuts and remove both covers (arrows).
Loosen screw connection (housing/
housing cover).

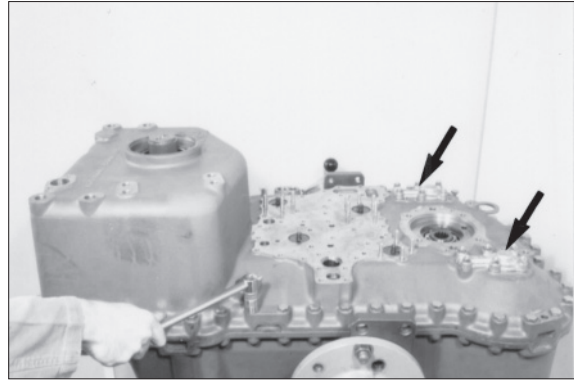

75773TM077

- ④ Drive both cylindrical pins out (arrows).

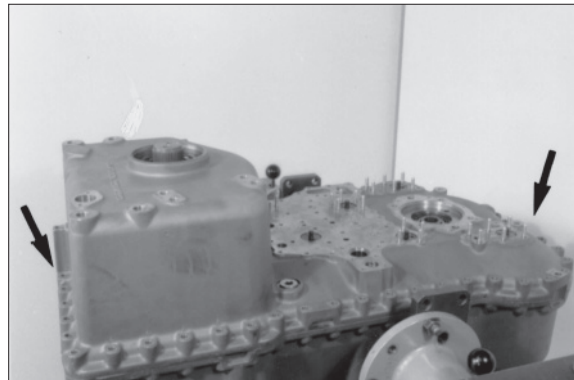

75773TM078

- ※ The following figures show the common
removal of all clutches.
The removal of single clutches without
use of the special tool (handles 5870
260 010) is due to the installation
conditions extremely difficult.

Besides there is the danger of injuries.

- ⑤ Locate all clutches by means of handles
in the housing cover.
Install eye bolts and hang in the lifting
device.

Handle (6 pieces needed)	5870 260 010
Eye bolt (M20, 2EA)	0636 804 003
Eye bolt (M16, 1EA)	0636 804 001
Puller device	5870 000 017
Lifting chain	5870 281 047

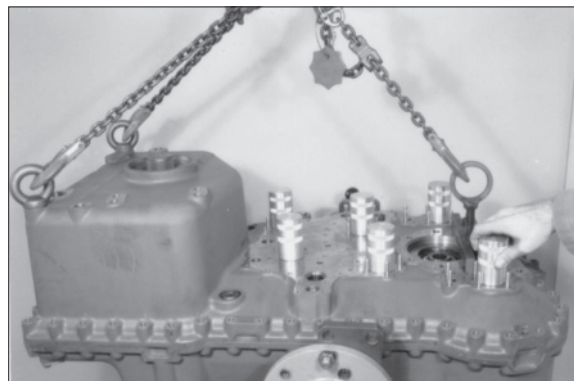

75773TM080

- ⑥ Separate housing cover along with clutches from the gearbox housing, using lifting device.

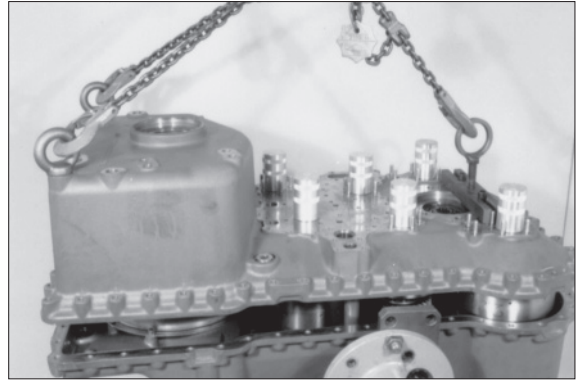

75773TM081

- ⑦ Fasten housing cover on the assembly car.

Assembly car 5870 350 000
Clamping bracket 5870 350 089

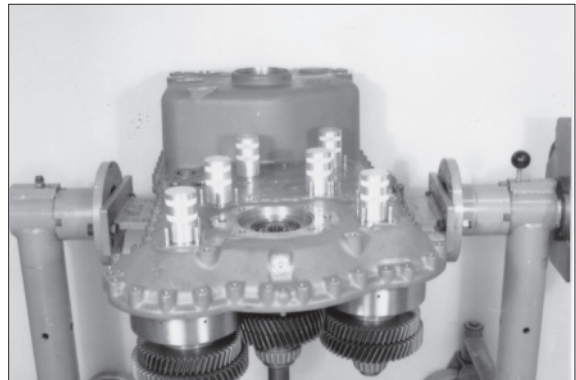

75773TM082

- ⑧ Loosen socket head screws and remove output shaft as well as the two oil collecting plate.

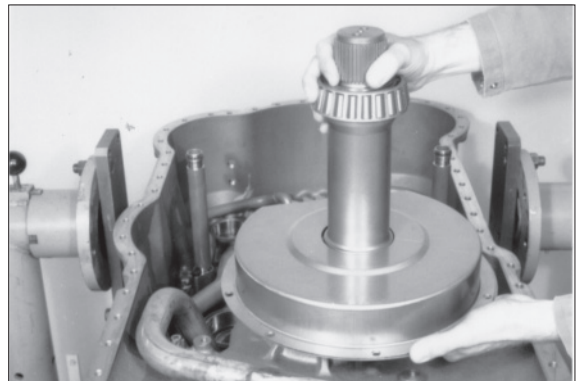

75773TM083

- ⑨ Pull off tapered roller bearing.
Remove opposite tapered roller bearing accordingly.
Grab sleeve 5873 002 038
Basic set 5873 002 001



75773TM084

⑩ Tilt housing cover 180°.

Illustration on the right shows the arrangement of the single clutches and the input in the housing cover.

AN	Input
KV	Clutch-Forward
KR	Clutch-Reverse
K1	Clutch-1st speed
K2	Clutch-2nd speed
K3	Clutch-3rd speed
K4	Clutch-4th speed

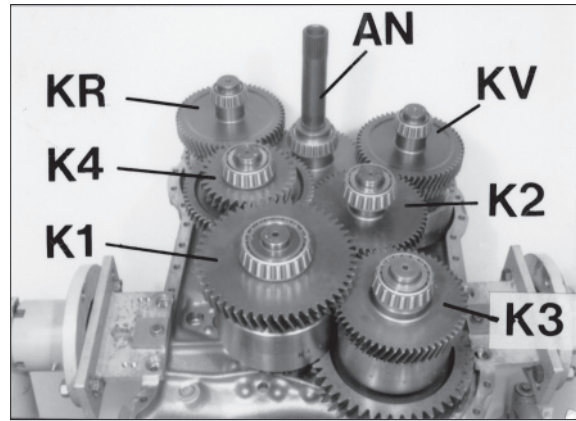

75773TM085

⑪ Remove handles (see figure).

Handles 5870 260 010

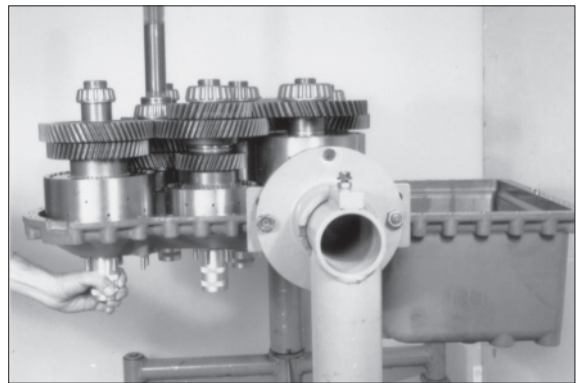

75773TM086

⑫ Lift clutch K4 a bit by means of pry bars and remove clutch K1.

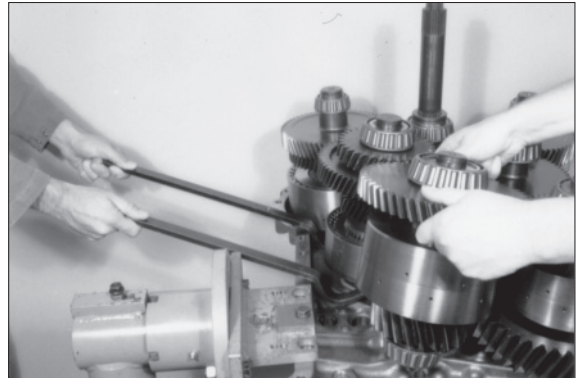

75773TM087

⑬ Remove clutch K2.

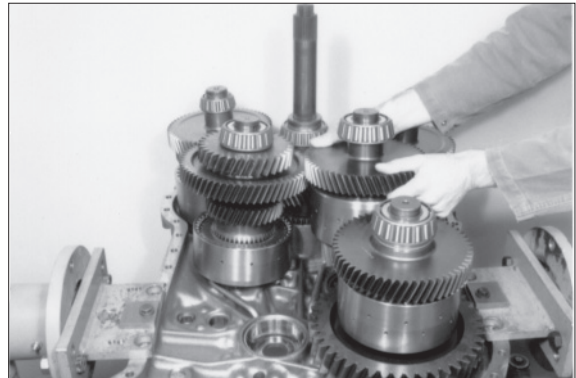

75773TM088

- ⑭ Remove clutch K3.

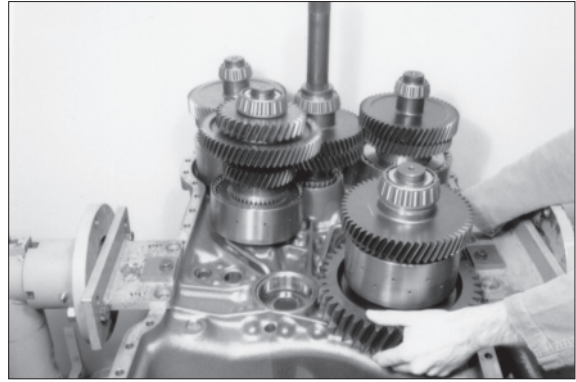

75773TM089

- ⑮ Lift clutch KV and KR by means of pry bars and remove clutch K4.

Pry bar 5870 345 065



75773TM090

- ⑯ Lift clutch KV and clutch KR as well as input together out of the housing cover. Remove bearing outer races out of the housing bores.

- ※ If contrary to the recommendation the tapered roller bearings of the clutches as well as of the input and output will not be renewed, the allocation (bearing inner races to bearing outer races) must at least be maintained.

Mark bearing inner race and bearing outer race accordingly to each other.

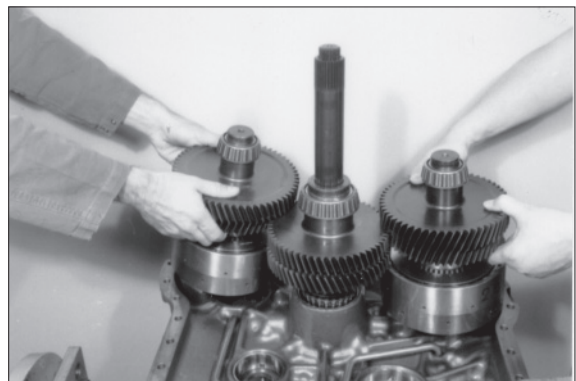

75773TM091

- ⑰ Tilt housing cover 90°.

Squeeze circlip out and separate pump shaft from housing cover.



75773TM092

- ⑮ Squeeze rectangular ring out (arrow) and press ball bearing from the shaft.

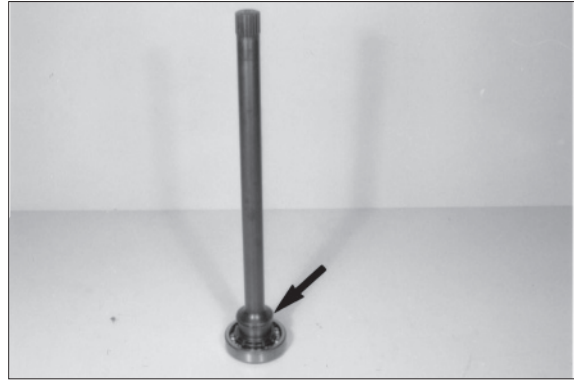

75773TM093

(6) Disassemble clutch KV and KR

※ The following figures show the disassembly of clutch KV.

- ① The disassembly of clutch KR is similar. Squeeze rectangular ring out (arrow).



75773TM095

- ② Pull tapered roller bearing from the shaft. Remove opposite tapered roller bearing accordingly.

Grab sleeve	5873 001 057
Grab sleeve	5873 001 059
Basic set	5873 001 000



75773TM096

- ③ Squeeze circlip out.



75773TM097

- ④ Separate plate carrier from the shaft.
Three leg puller 5870 971 003



75773TM098

- ⑤ Squeeze snap ring out and remove plate pack.

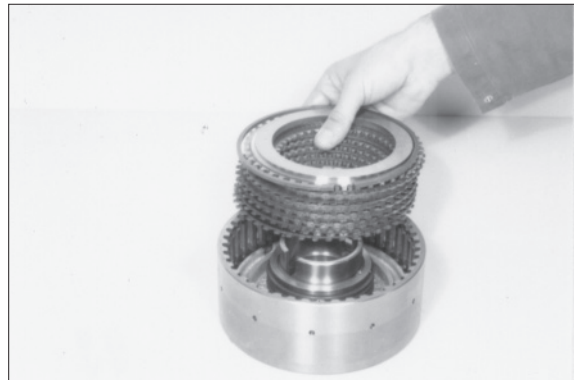

75773TM099

- ⑥ Preload compression spring, squeeze snap ring out and remove components.
Assembly aid 5870 345 088



75773TM100

- ⑦ Lift piston by means of compressed air out of the cylinder bore and remove it.

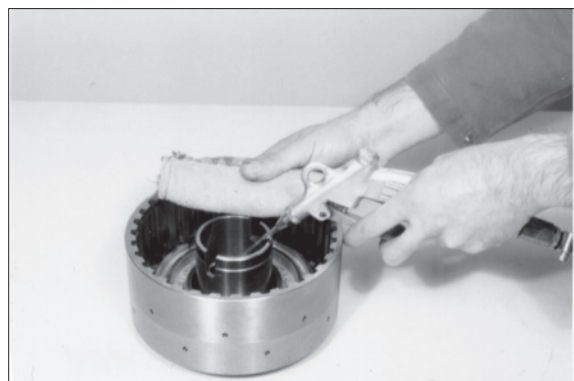

75773TM101

- ⑧ Remove both O-rings (arrows).

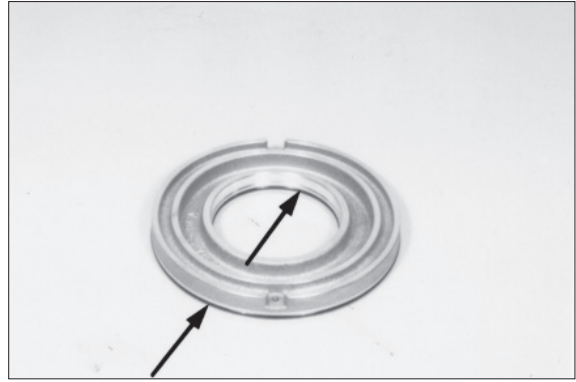

75773TM102

- ⑨ Lift idler gear a bit by means of pry bare.

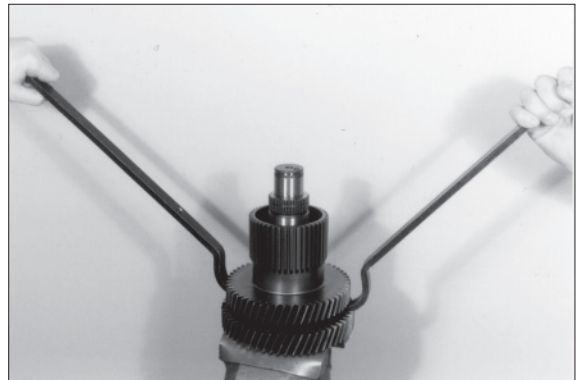

75773TM103

- ⑩ Apply puller and separate idler gear from the clutch shaft.

Pry bar

5870 345 065

Puller

5870 971 003



75773TM104

- ⑪ Squeeze circlip out and remove ball bearing.

- ※ The disassembly of clutch KR has to be carried out accordingly.

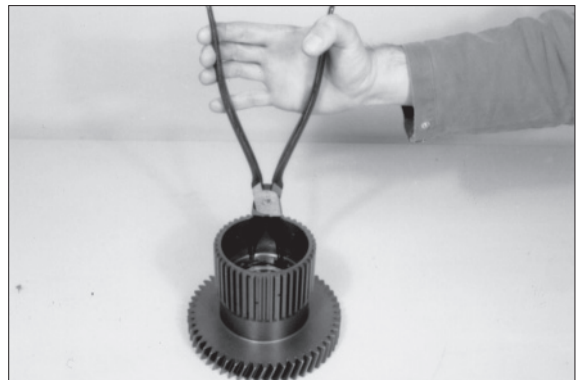

75773TM105

(7) Disassemble clutch K1, K2 and K3

※ The following figures show the disassembly of clutch K3.

The disassembly of the clutches K1 and K2 is similar.

① Squeeze rectangular ring out.

Pull tapered roller bearing from the shaft.
Remove the opposite tapered roller bearing accordingly.

Grab sleeve (bearing 33800) 5873 001 059

Grab sleeve (bearing 39500) 5873 002 038

Basic set 5873 001 000

Basic set 5873 002 001

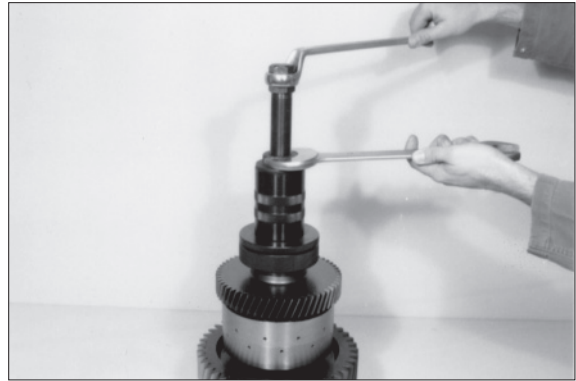

75773TM110

② Remove running disk, axial needle cage and axial washer.

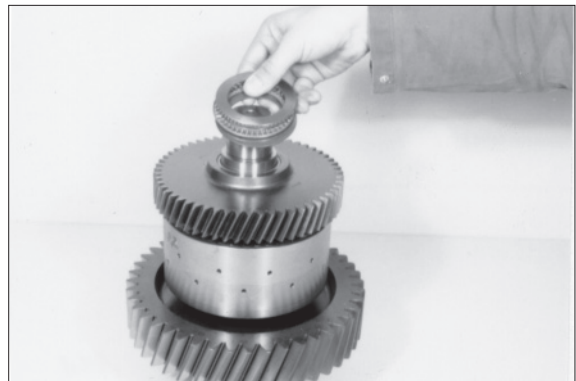

75773TM111

③ Remove idler gear.



75773TM112

- ④ Remove both needle bearings as well as the axial bearing (complete).

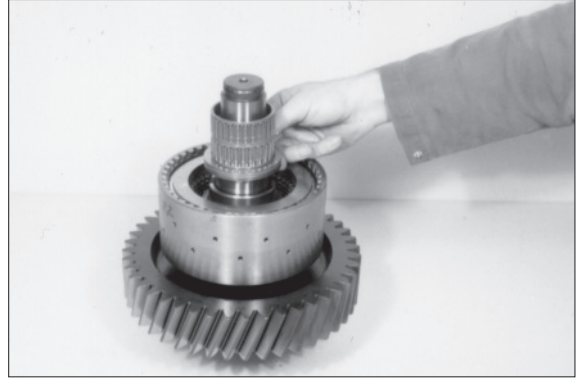

75773TM113

- ⑤ Squeeze snap ring out and remove plate pack.



75773TM114

- ⑥ Preload cup-spring pack and squeeze snap ring out.
Remove released components.
Assembly aid 5870 345 088

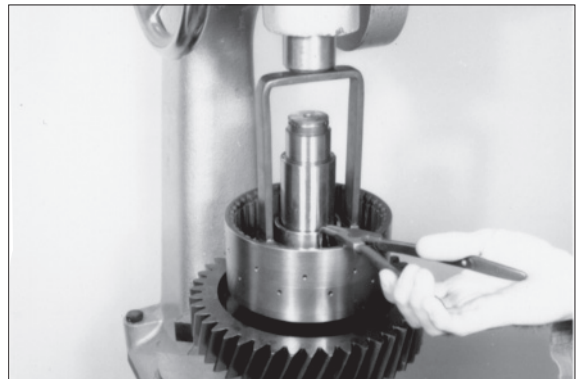

75773TM115

- ⑦ Squeeze circlip into the groove of the plate carrier.
Apply puller on the circlip and pull plate carrier from the clutch shaft.
Puller 5870 970 004
Circlip 0630 502 053



75773TM116

(8) Disassemble clutch K4

- ① Squeeze rectangular ring out (arrow).



75773TM120

- ② Pull tapered roller bearing from the shaft.
Remove opposite tapered roller bearing accordingly.

Grab sleeve 5873 001 057

Grab sleeve 5873 001 059

Basic set 5873 001 000



75773TM121

- ③ Squeeze circlip out and separate plate carrier from the shaft.

Three leg puller 5870 971 003



75773TM122

- ④ Squeeze snap ring out and remove plate pack.

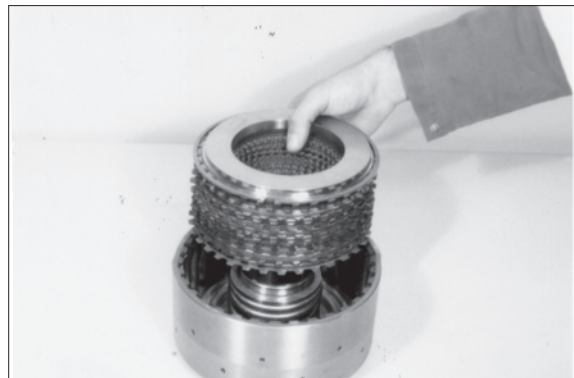

75773TM123

- ⑤ Preload cup-spring pack and squeeze snap ring out.
Remove released components.
Remove piston.
Assembly aid 5870 345 008



75773TM124

- ⑥ Lift piston by means of compressed air out of the cylinder bore and remove it.

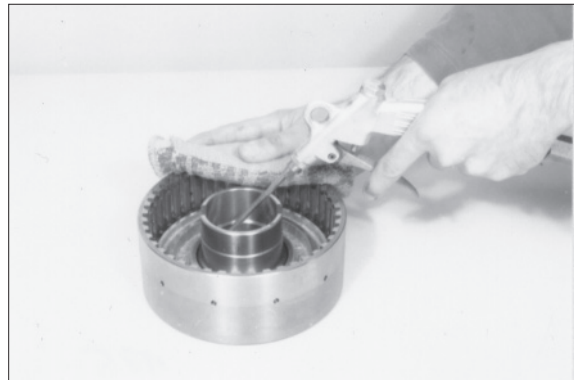

75773TM125

- ⑦ Take off the idler gear and remove release components.
※ The separation of shaft and gear is not possible (shrink fit).



75773TM126

(9) Disassemble drive shaft

- ① Squeeze rectangular ring out.
Pull off tapered roller bearing.
Remove opposite tapered roller bearing accordingly.
Grab sleeve 5873 002 045
Basic set 5873 002 001
Basic set 5873 002 006



75773TM130

- ② If necessary, press turbine shaft out of the drive shaft.
* The turbine shaft is axially fixed with a snap ring which will be destroyed at the pressing out.

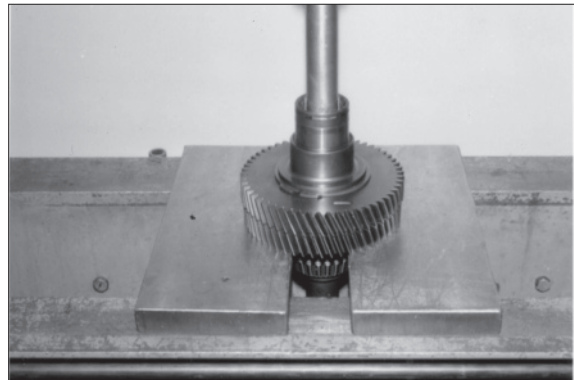

75773TM131

2) REASSEMBLY

(1) Install oil tubes

- ※ To ensure the correct installation of the oil tubes, the use of the indicated special tool is imperative.

- ① Insert suction pipe (1), pressure pipes (2) and pressure pipelubrication (3) into the housing bores.

Fasten suction and pressure pipes by means of socket head screws.

- Torque limit : 2.3 kgf · m (17.0 lbf · ft)

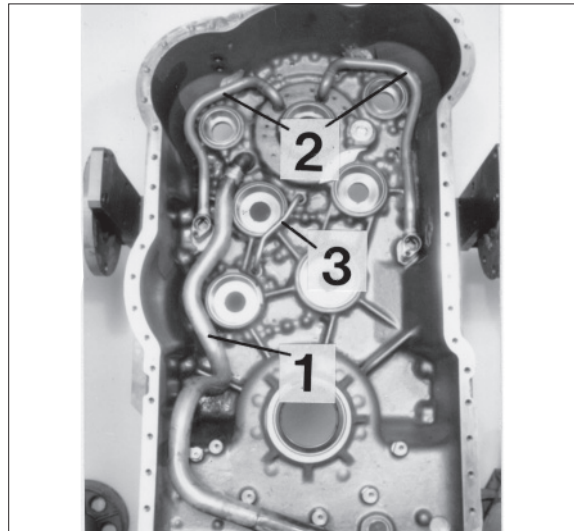

75773TM140

- ② Tilt housing 180°.

Roll suction as well as pressure pipes (arrows) into the housing bores, using special tool.

The pipe end must be maximally plane with the housing face.

If necessary, equalize projection of pipe.

Rolling tool 5870 600 003

Rolling tool 5870 600 005

Rolling tool 5870 600 007

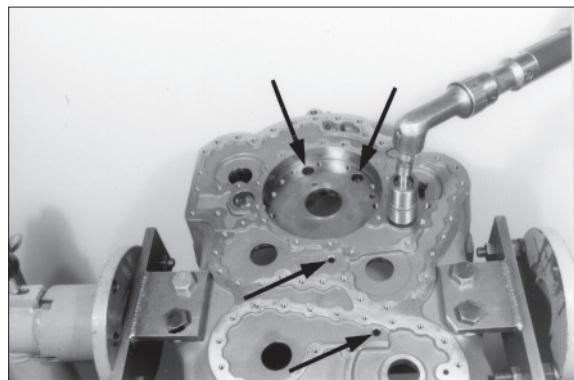

75773TM141

- ③ Insert O-rings (2EA/pipe) into the annular grooves of the two oil tubes and oil them.



75773TM142

- ④ Assemble both oil tubes(Arrows) until contact is obtained.
Equip screw plug with new O-ring and install it.
• Torque limit : 14.3 kgf · m (103 lbf · ft)

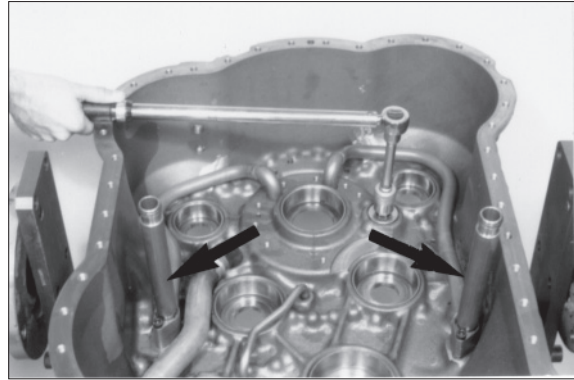

75773TM143

- ⑤ Insert both oil tubes (arrows) into the housing cover, tilt housing cover 180° and roll oil tubes into the housing bores.
※ The tube end must be maximally plane with the housing face.
If necessary, equalize projection of the tube.
Rolling tool 5870 600 008

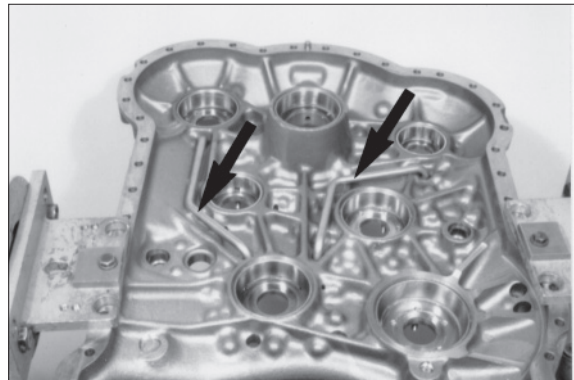

75773TM144

- ⑥ Mount studs (M8 × 25).
• Torque limit : 0.92 kgf · m (6.64 lbf · ft)
Wet screw in thread with loctite (type No. 262).
Equip plugs (arrows) with new O-rings and install them
• Torque limit (M16 × 1.5) : 4.1 kgf · m (29.5lbf · ft)
• Torque limit (M18 × 1.5) : 5.1 kgf · m (36.9lbf · ft)
• Torque limit (M26 × 1.5) : 8.2 kgf · m (59.0lbf · ft)

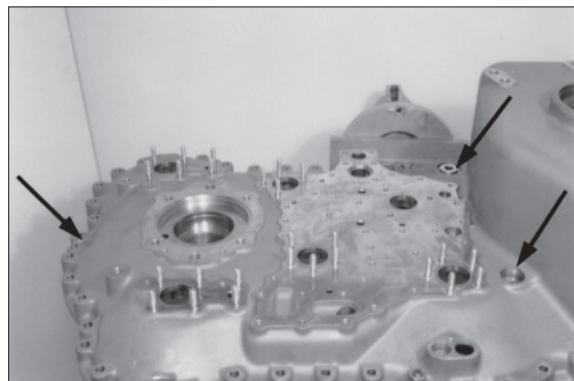

75773TM145

- ⑦ Insert sealing cover, with the recess showing upward.
※ Wet contact face with loctite (type No. 262).

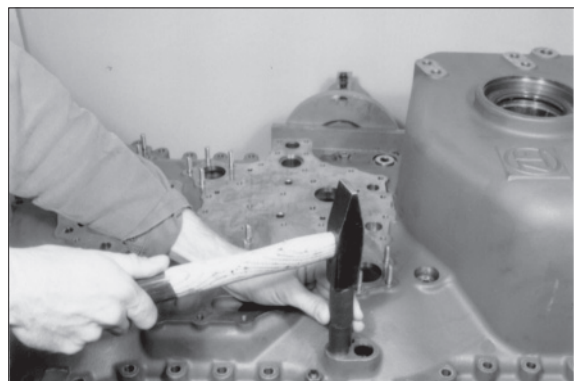

75773TM146

(2) Reassemble clutch KV and KR

- ※ The following figure show the reassembly of the clutch KV. The reassembly of the clutch KR has to be carried out accordingly.

Preassemble plate carrier

- ① Check function of the purge valve.
 - ※ Ball must not stick, if necessary, clean with compressed air.

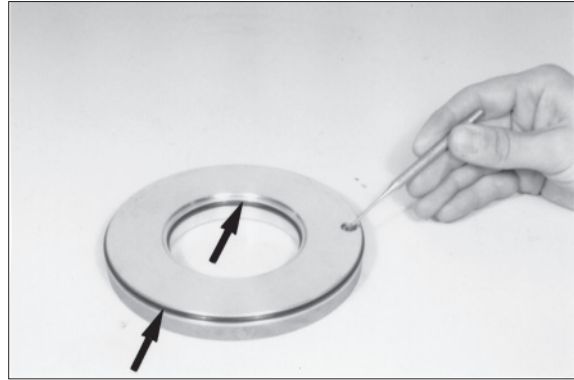

75773TM150

- ② Insert both O-ring (arrows) scrollfree into the grooves of the piston and oil. Introduce piston until contact is obtained.
 - ※ Pay attention to the installation position, see figure.

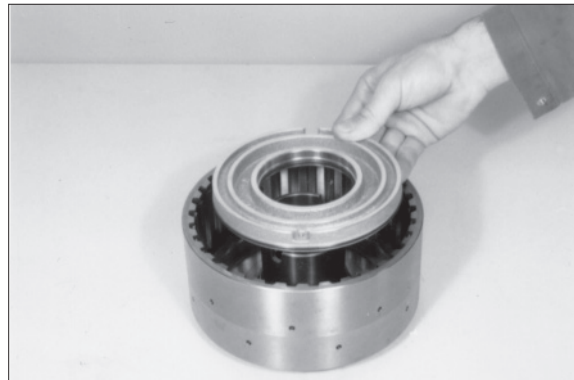

75773TM151

- ③ Install disk, compression spring and guide ring.



75773TM152

- ④ Preload compression spring and fix it by means of snap ring.
Assembly aid 5870 345 088



75773TM153

Plate pack KV, KR

- ※ The plate arrangement respectively stacking of clutch KV and KR is identical.
- ⑤ The following draft shows the installation position of the components.

- 1 Plate carrier
- 2 Piston
- 3 Outer plate-one sided coated (1 piece)
- 4 Inner plates (10 pieces)
- 5 Outer plates-coated on both sides (10 pieces)
- 6 Snap ring (optional $s = 2.1 \sim 4.2$ mm)
- 7 End shim

Effective number of friction surfaces = 20

- ※ Install outer plate 3 with the uncoated side facing the piston.
- Install on the end-shim side two outer and inner plates each.

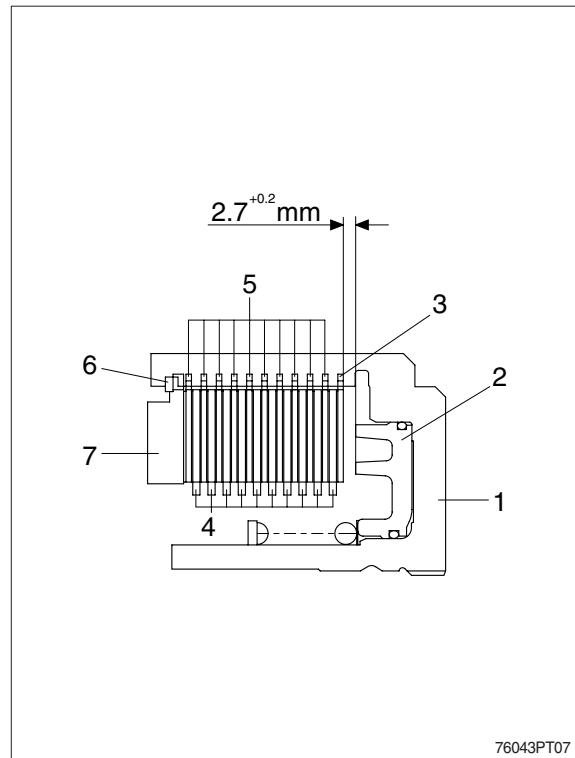

76043PT07

Adjust plate clearance : $2.7+0.2$ mm

- ※ For the adjustment of the plate clearance are snap rings of different thickness available.
- To ensure a faultless measuring result, install plates for the moment without oil.
- ⑥ Introduce plate pack according to the upper draft.



75773TM155

- ⑦ Lay on the end shim and squeeze the snap ring in (e.g. $s = 2.55$ mm)

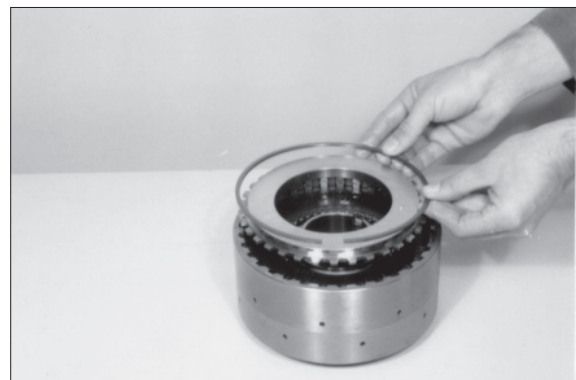

75773TM156

- ⑧ Press on end shim with about 100N (10 kg), apply dial indicator and set it at zero.

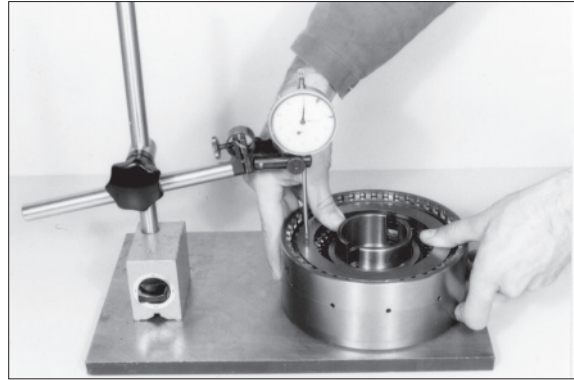

75773TM157

- ⑨ Now, push the end shim by means of screw driver against snap ring until contact is obtained (upward) and read plate clearance on the dial indicator.

※ In case of a deviation from the required plate clearance, correct with corresponding snap ring (s = 2.1~4.2 mm).

※ After the adjustment of the plate clearance has been carried out, remove the plate pack, oil plates and install it again. Use oil SAE 10W-30/15W-40.

Magnetic stand 5870 200 055
Dial indicator 5870 200 057

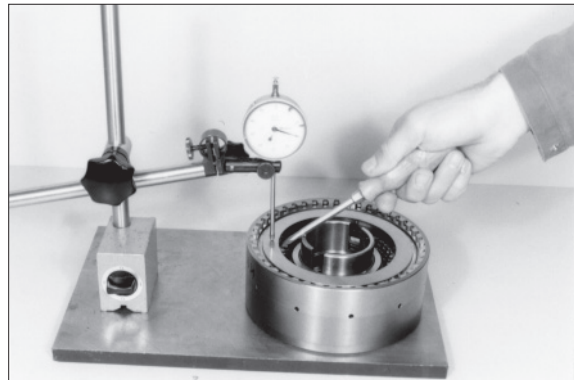

75773TM158

- ⑩ Introduce idler gear until all inner plates are accommodated.

※ This step makes the later assembly of the idler gear easier.

Now, remove the idler gear again.



75773TM159

- ⑪ Mount stud (arrow).
Wet screw-in thread with loctite (type No.241).
· Torque limit (M10) : 1.7 kgf · m
(12.5 lbf · ft)

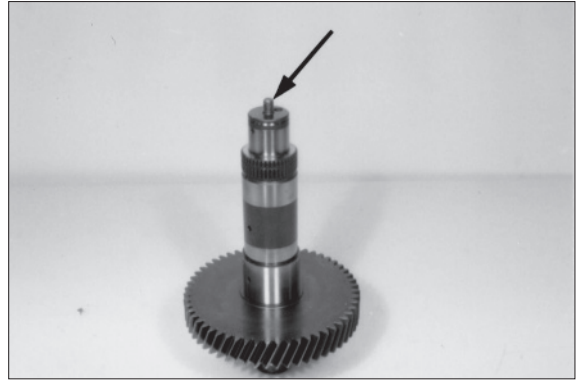

75773TM160

- ⑫ Insert ball bearing until contact is obtained and fix by means of circlip.



75773TM161

- ⑬ Assemble needle bearing.



75773TM162

- ⑭ Press idler gear against shoulder.
※ Support it on the bearing inner race.

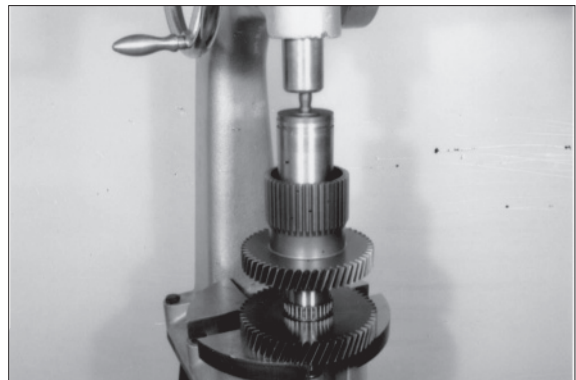

75773TM163

- ⑮ Heat inner diameter of plate carrier
(About 120°C).
Hot air blower 220V 5870 221 500
Hot air blower 110V 5870 221 501



75773TM164

- ⑯ Assemble preassembled plate carrier
until contact is obtained.



75773TM165

- ⑰ Locate plate carrier axially by means of
circlip.



75773TM166

- ⑱ Check function of clutch by means of
compressed air.
※ At correctly installed components, the
closing resp. opening of the clutch is
clear audible.



75773TM167

- ① Press tapered roller bearing against shoulder.
Install opposite tapered roller bearing accordingly.



75773TM168

- ② Squeeze rectangular rings in (arrow) and let them snap in.

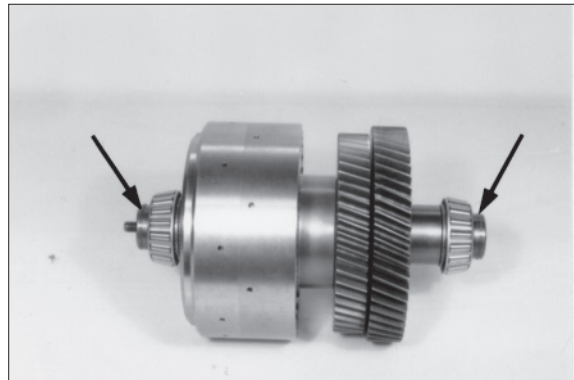

75773TM169

(3) Reassemble clutch K1, K2 and K3

- ※ The following figures show the reassembly of clutch K3.

The reassembly of the clutches K1 and K2 has to be carried out accordingly.

- ① Install stud (arrow).
※ Wet screw in thread with loctite (type No. 241).
· Torque limit (M10) : 1.7 kgf · m (12.5 lbf · ft)

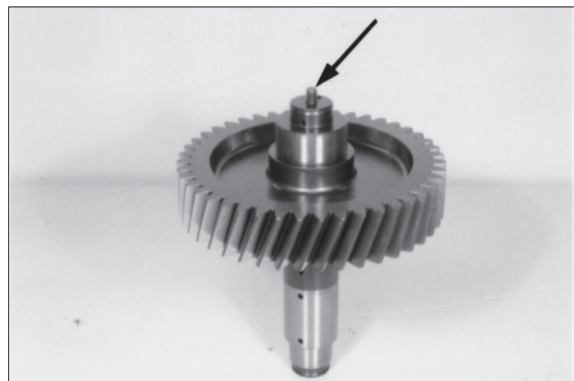

75773TM175

- ② Heat inner diameter of plate carrier.



75773TM176

- ③ Assemble plate carrier until contact is obtained.

Hot air blower 220V 5870 221 500

Hot air blower 110V 5870 221 501



75773TM177

- ④ Check function of the purge valve.

※ Ball must not stick, if necessary clean with compressed air.

Insert both O-rings (arrows) scrollfree into the grooves of the piston and oil.

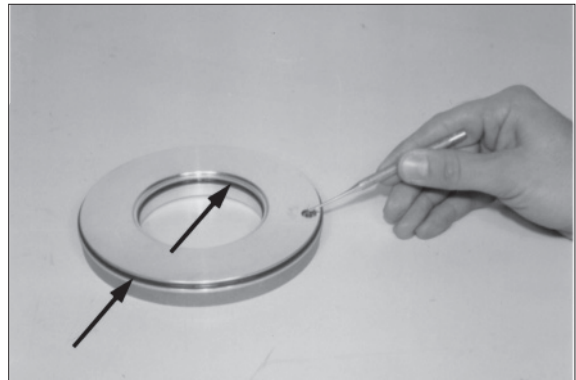

75773TM178

- ⑤ Introduce piston until contact is obtained.

※ Pay attention to the installation position, see figure.

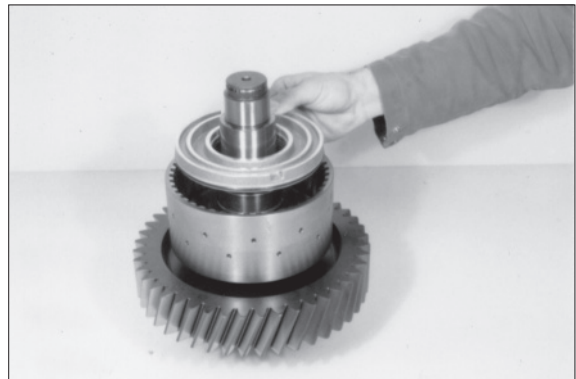

75773TM179

- ⑥ Lay on cup spring pack and guide ring.

※ Pay attention to the stacking of the cup springs, see the next draft.

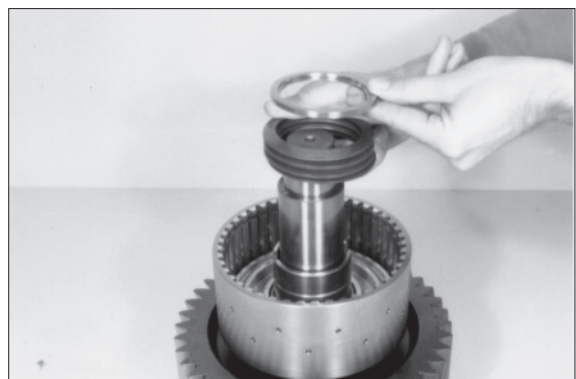

75773TM180

- ⑦ Preload cup spring pack and fix it by means of snap ring.
 Assembly aid 5870 345 088

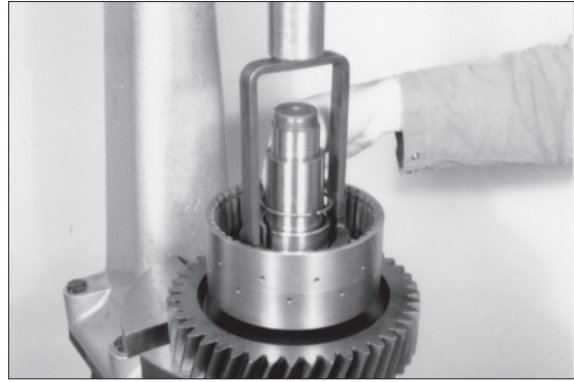

75773TM181

- ※ The plate arrangement of clutch K1 is identical with clutch K2 and K3.
 In this connection see the following drafts.

Plate pack K1

- 1 Plate carrier
 - 2 Piston
 - 3 Outer plate-one side coated (1 piece)
 - 4 Inner plates (9 pieces)
 - 5 Outer plates-on both sides coated (9 pieces)
 - 6 Snap ring (optional $s=2.1\sim 4.2$ mm)
 - 7 End shim
- Effective number of friction surfaces = 18

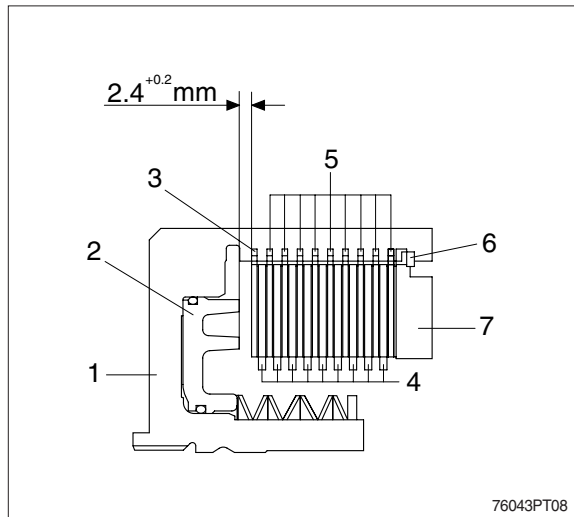

76043PT08

- ※ Install outer plate 3 with the uncoated side facing the piston.

Plate pack K2 and K3

- 1 Plate carrier
 - 2 Piston
 - 3 Outer plate-one side coated (1 piece)
 - 4 Inner plates (7 pieces)
 - 5 Outer plates-on both side coated (7 pieces)
 - 6 Snap ring (optional $s= 2.1\sim 4.2$ mm)
 - 7 End shim
- Effective number of friction surfaces = 14

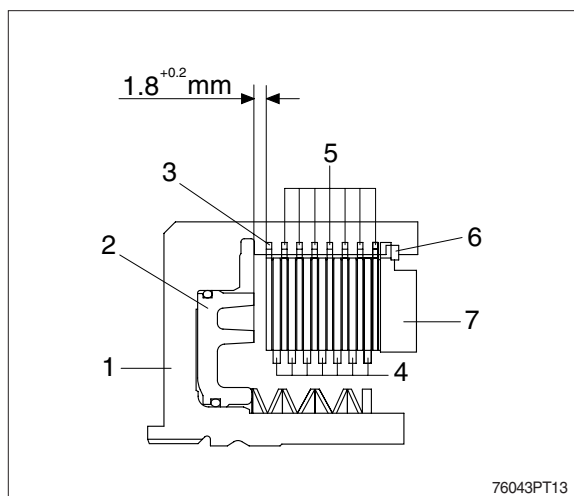

76043PT13

- ※ Install outer plate 3 with the uncoated side facing the piston.
 Install on the end-shim two outer and inner plates each.

Adjust plate clearance

Plate clearance clutch K1 $2.4^{+0.2}$ mm

Plate clearance clutch K2 and K3
 $1.8^{+0.2}$ mm

※ For the adjustment of the plate clearance are snap rings with different thickness available.

To ensure a faultless measuring result, install the plates for the moment without oil.

Introduce plate pack according to drafts / page 3-118.

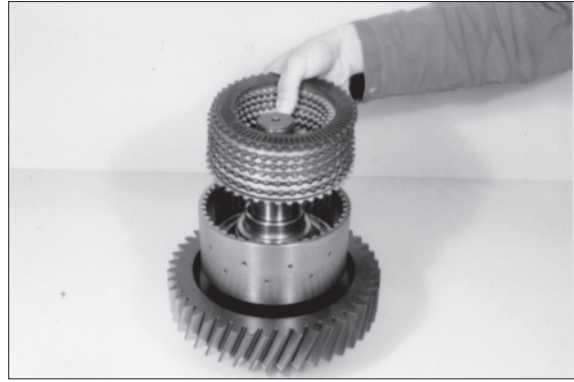

75773TM185

⑧ Lay on the end shim and squeeze circlip in (e.g. $s = 3.1$ mm).



75773TM186

⑨ Press on the end shim with about 100N (10 kg), apply dial indicator and set it at zero.

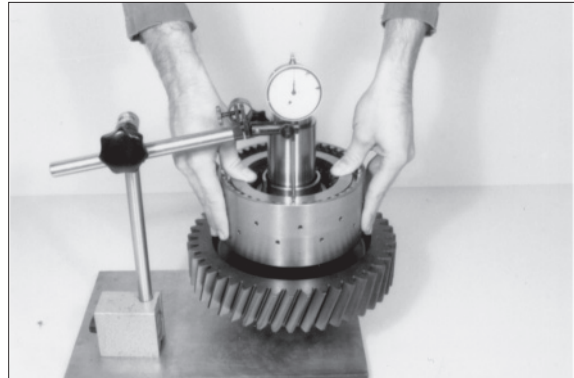

75773TM187

⑩ Now, push the end shim by means of screw driver against snap ring until contacts is obtained (upward) and read plate clearance on the dial indicator.

※ In case of a deviation from the required plate clearance, correct with corresponding snap ring ($s = 2.1 \sim 4.2 \text{ mm}$).

After the adjustment of the plate clearance has been carried out, remove the plate pack, oil plates and install it again.

Use oil SAE 10W-30/15W-40.

Magnetic stand 5870 200 055

Dial indicator 5870 200 057

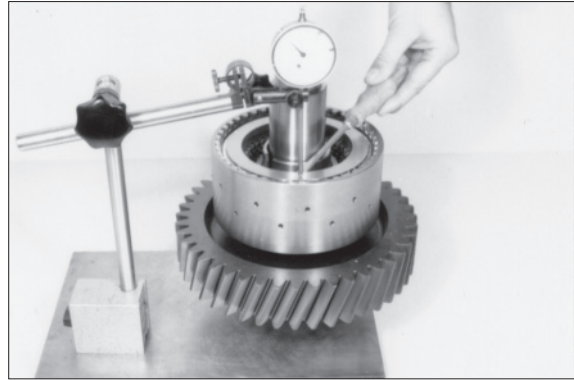

75773TM188

⑪ Assemble running disk 1 ($55 \times 78 \times 5$), axial needle cage 2 and axial washer 3 ($55 \times 78 \times 1$).

Install running disk 1, with the chamber facing the axial needle cage.

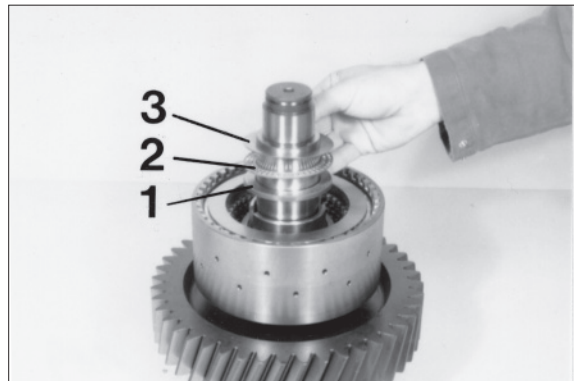

75773TM189

⑫ Assemble both needle bearings.

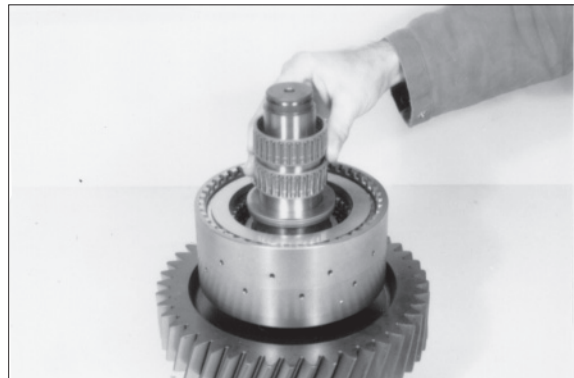

75773TM190

- ⑬ Introduce idler gear until all inner plates are accommodated.



75773TM191

- ⑭ Assemble axial washer 3 (55×78×1), axial needle cage 2 and running disk 1 (55×78×5).
- ※ Install running disk 1, with the chamfer facing the axle needle cage.
 - ※ Only if the running disk in overlapping with the shaft collar is ensured that all inner plates are accommodated.

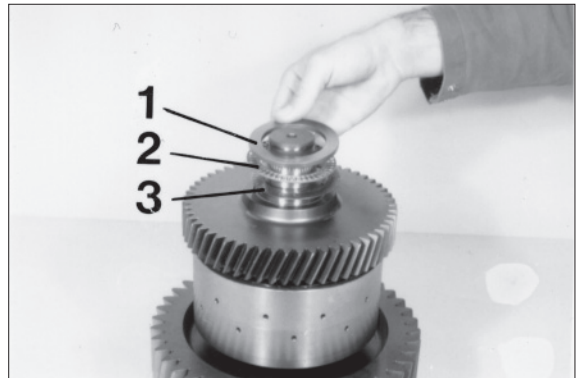

75773TM192

- ⑮ Press tapered roller bearing against shoulder.
Press opposite tapered roller bearing against shoulder.

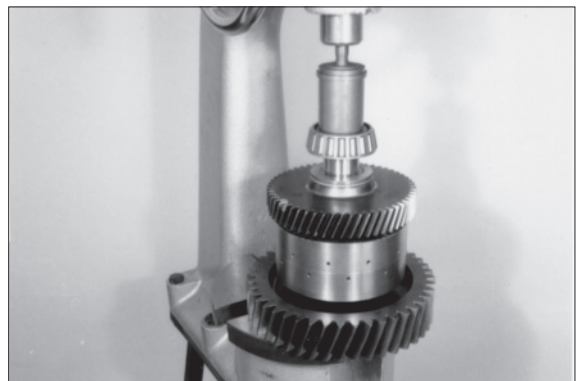

75773TM193

- ⑯ Check function of the clutch by means of compressed air.
- ※ At correctly installed components, the closing respectively opening of the clutch is clearly audible.

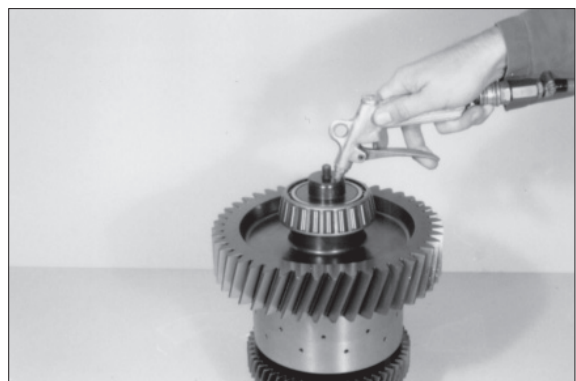

75773TM194

- ⑰ Squeeze rectangular ring in (arrow) and let it snap in.
Install opposite rectangular ring accordingly.

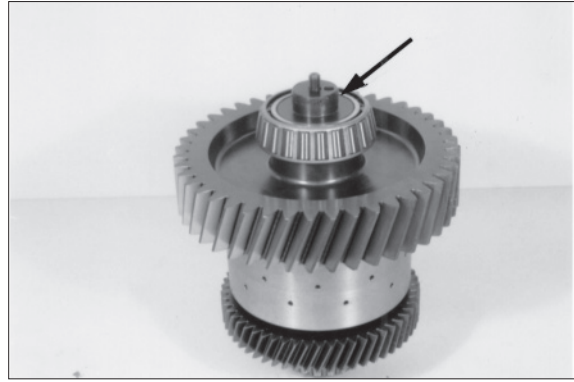

75773TM195

(4) Reassemble clutch K4

- ① Undercool shaft (about -80°C), heat gear (about $+120^{\circ}\text{C}$) and assemble it until contact is obtained.

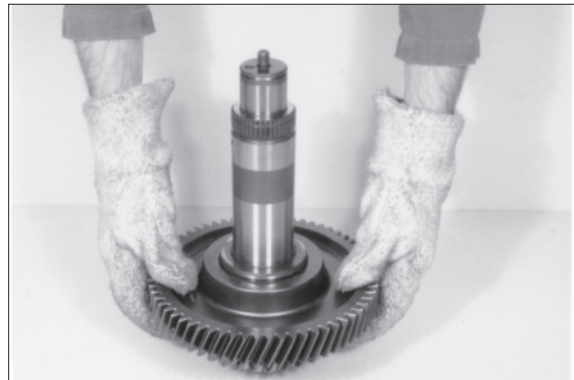

75773TM200

- ② Fix gear axially by means of circlip.
Set of external pliers 5870 900 015

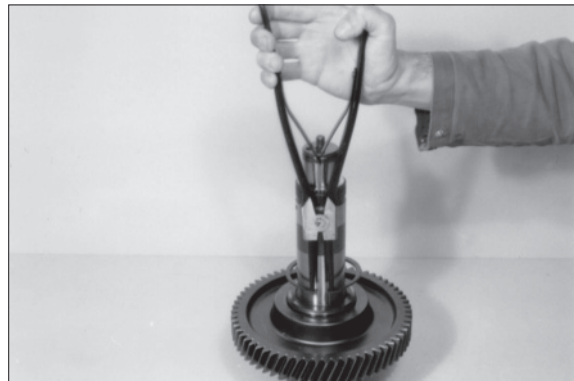

75773TM201

- ③ Install stud (arrow).
※ Wet screw-in thread with loctite (type No. 241).
• Torque limit (M10) : $1.7 \text{ kgf} \cdot \text{m}$ ($12.5 \text{ lbf} \cdot \text{ft}$)

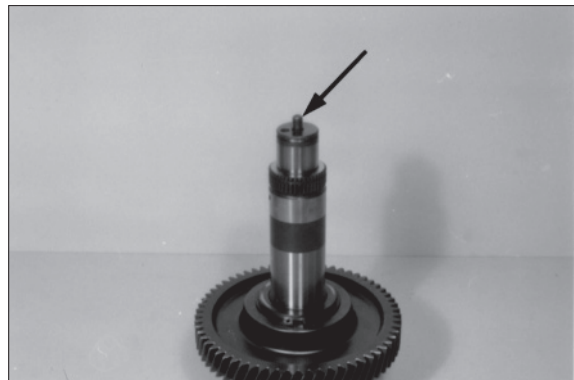

75773TM202

- ④ Check function of the purge valve.
※ Ball must not stick, if necessary clean with compressed air.
Insert both O-ring (arrow) scrollfree into the grooves of the piston and oil them.

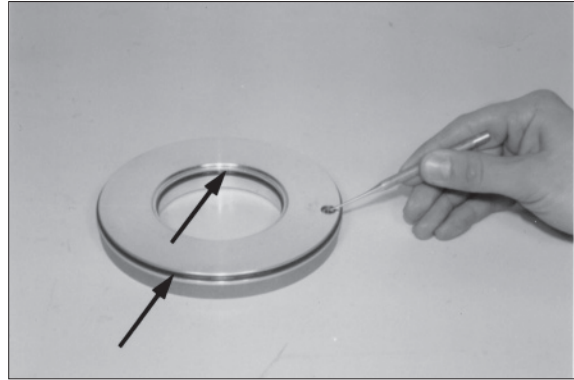

75773TM203

- ⑤ Introduce piston until contact is obtained.
※ Pay attention to the installation position, see figure.



75773TM204

- ⑥ Install cup-spring pack and guide ring.
※ Pay attention to the stacking of the cup springs, see draft, page 3-110.

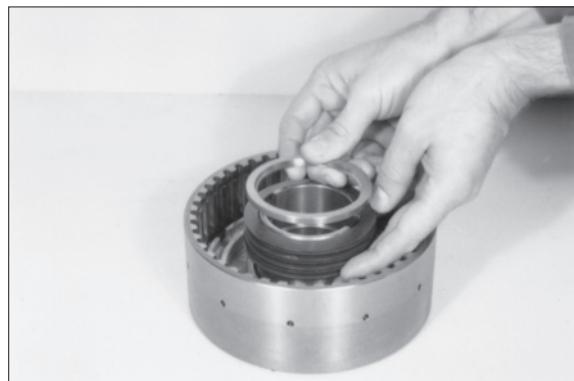

75773TM205

- ⑦ Preload cup-spring pack and fix it by means of snap ring.
Assembly aid 5870 345 088



75773TM206

Plate pack K4

※ The following draft shows the installation position of the components.

- 1 Plate carrier
- 2 Piston
- 3 Outer plate-one side coated (1 piece)
- 4 Inner plates (5 pieces)
- 5 Outer plates-coated on both sides (5 pieces)
- 6 Snap ring (optional $s = 2.1\sim 4.2$ mm)
- 7 End shim

Effective number of friction surfaces = 10

※ Install outer plate 3 with the uncoated side facing the piston.

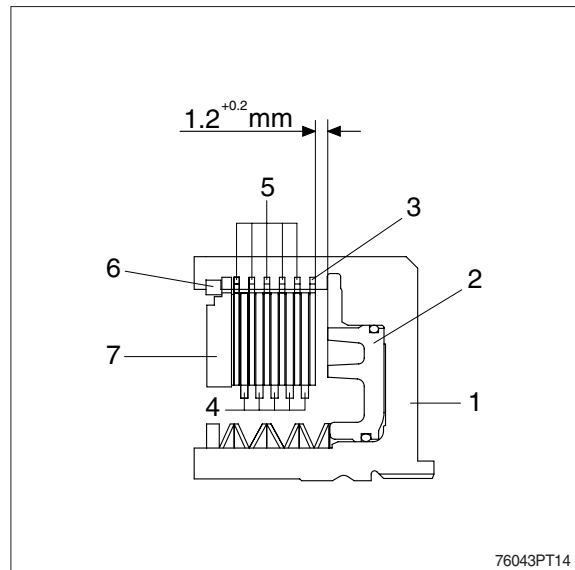

Adjust plate clearance = $1.2^{+0.2}$ mm

※ For the adjustment of the plate clearance are snap rings of different thickness available.

To ensure a faultless measuring result, install plates for the moment without oil.

⑧ Introduce plate pack according to the draft.



⑨ Lay on end shim and squeeze snap ring in (e.g. $s = 3.4$ mm).

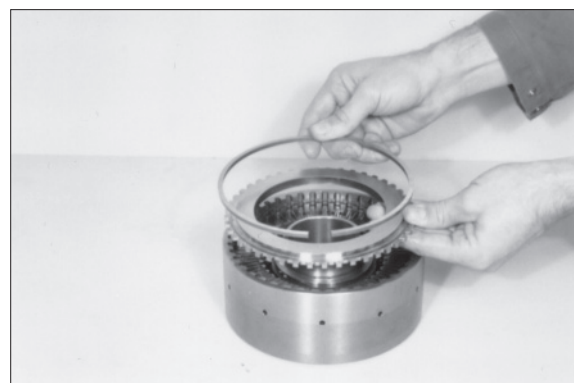

- ⑩ Press on the end shim with about 100N (10 kg), apply dial indicator and set it at zero.

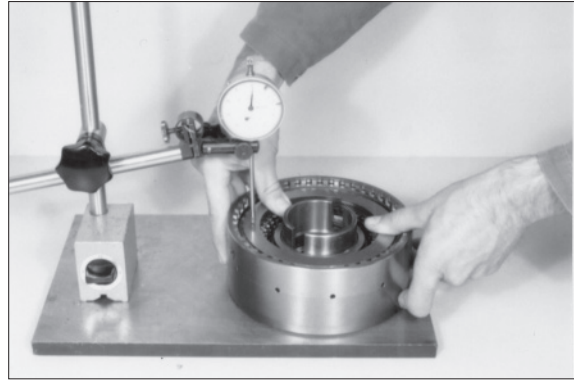

75773TM212

- ⑪ Now, push the end shim by means of screw driver against snap ring until contacts is obtained (upward) and read plate clearance on the dial indicator.

※ In case of a deviation from the required plate clearance, correct with corresponding snap ring ($s=2.1\sim 4.2$ mm). After the adjustment of the plate clearance has been carried out, remove the plate pack, oil plates and install it again.

※ Use oil SAE 10W-30/15W-40.

Magnetic stand 5870 200 055

Dial indicator 5870 200 057

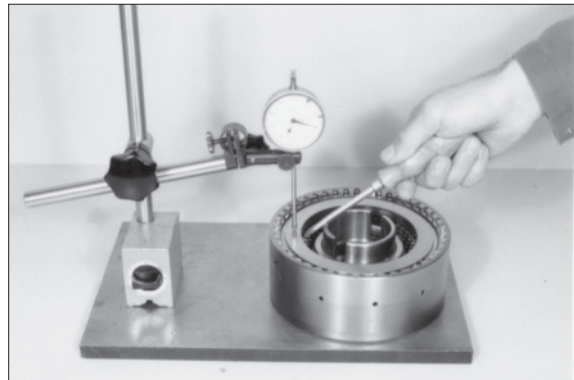

75773TM213

- ⑫ Introduce idler gear until all inner plates are accommodated.

※ This step makes the later assembling of the idler gear easier.

Now, remove idler gear again.



75773TM214

- ⑬ Assemble both axial washers as well as needle case.
- ※ Upper and lower axial washer have the same thickness (55×78×1).

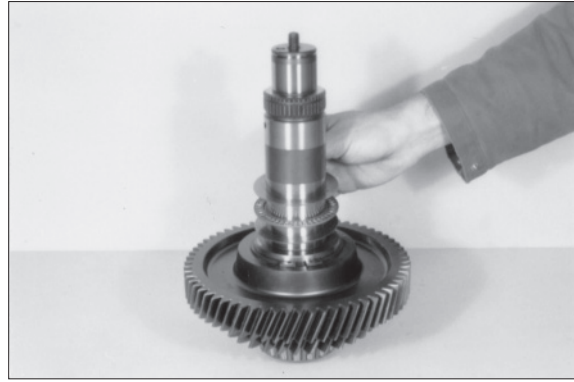

75773TM215

- ⑭ Assemble both needle bearings.



75773TM216

- ⑮ Assemble idler gear.

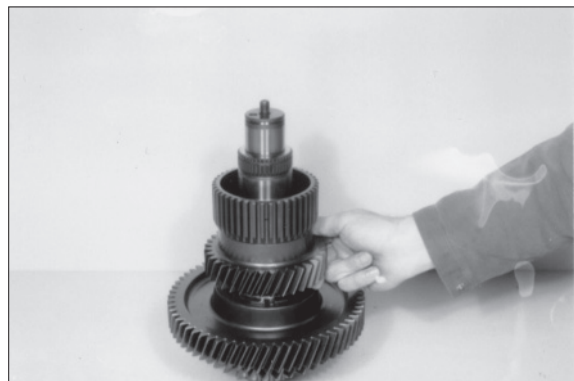

75773TM217

- ⑯ Assemble axial washer 3 (55×78×1), needle cage 2 and running disk 1 (55×78×5).
- ※ Install running disk 1, with the chamfer facing the needle cage.

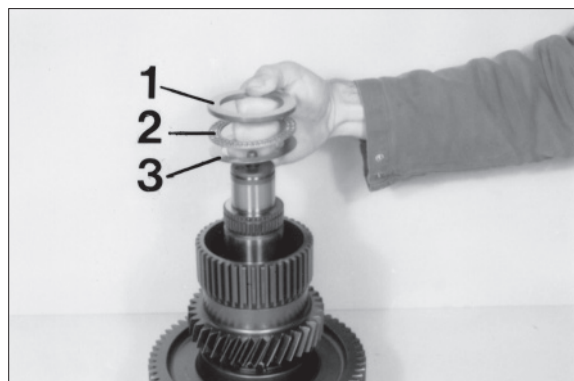

75773TM218

- ⑰ Heat inner diameter of the plate carrier (about 120°C).
Assemble preassembled plate carrier until all inner plates are accommodated.
* Use safety gloves.

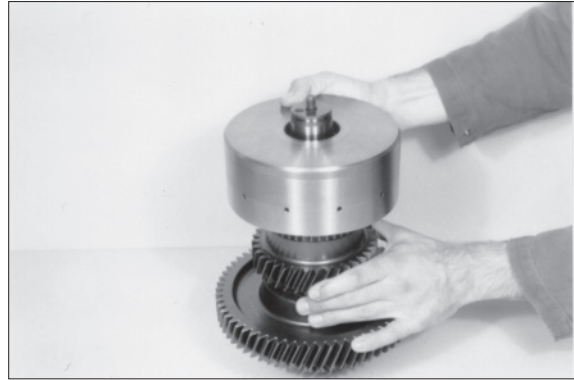

75773TM219

- ⑱ Fix plate carrier axially by means of circlip.
Set of external pliers 5870 900 015



75773TM220

- ⑲ Check function of the clutch by means of compressed air.
* At correctly installed components, the closing respectively opening of the clutch is clearly audible.



75773TM221

- ⑳ Press tapered roller bearing against shoulder.
Install opposite tapered roller bearing.



75773TM222

Squeeze rectangular ring in (arrow) and let it snap in.
Install opposite rectangular ring.



75773TM223

(5) Preassemble drive shaft

- ① Undercool the drive shaft (about -80°C), heat the gear (about $+120^{\circ}\text{C}$) and assemble it until contact is obtained.



75773TM225

- ② Fix gear axially by means of circlip.

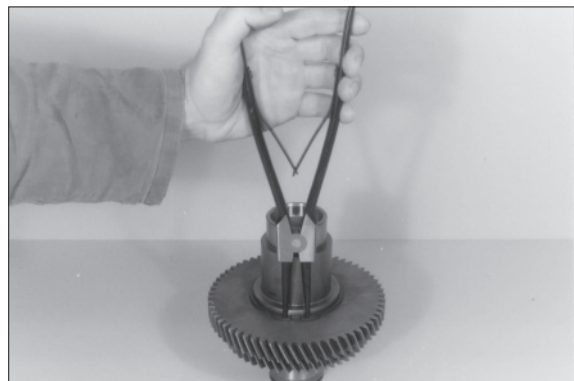

75773TM226

- ③ Squeeze snap ring into groove of the turbine shaft.

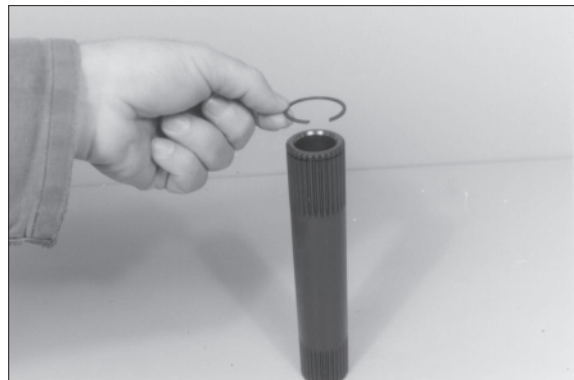

75773TM227

- ④ Introduce turbine shaft until the snap ring snaps into the groove of the drive shaft turbine shaft is axially fixed.



75773TM228

- ⑤ Press tapered roller bearing against shoulder.
Now, squeeze rectangular ring into the groove of the drive shaft and let it snap in.
Install opposite tapered roller bearing.

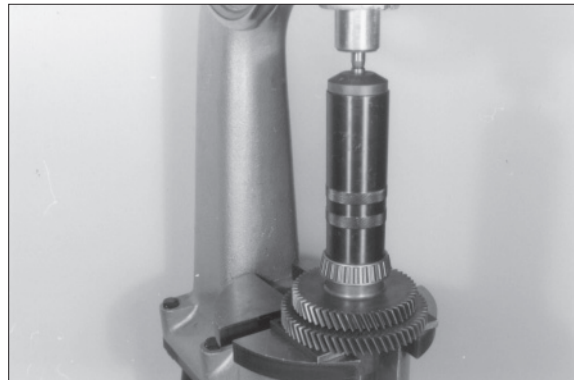

75773TM229

(6) Preassemble and install output

- ① Lay on screening plate



75773TM230

- ② Heat tapered roller bearing and assemble it until contact is obtained.
Install opposite tapered roller bearing accordingly.



75773TM231

③ Insert all bearing outer races into the bearing bores of the housing. Install O-ring (arrows).

※ At the use of already run bearings, pay attention to the allocation of the bearing outer races, see also note/page 3-86.

AN	Input
KV	Clutch-Forward
KR	Clutch-Reverse
K1	Clutch-1st speed
K2	Clutch-2nd speed
K3	Clutch-3rd speed
K4	Clutch-4th speed
AB	Output

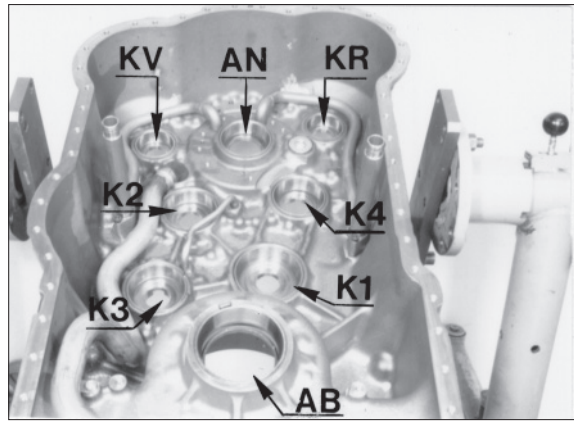

75773TM232

④ Lay on screening plate.

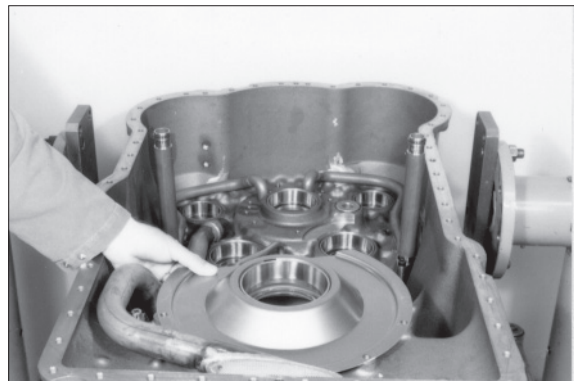

75773TM233

⑤ Insert preassembled output shaft. Fix screening plates by means of socket head screws.

- Torque limit (M8/8.8) : 2.3 kgf · m
(17.0 lbf · ft)

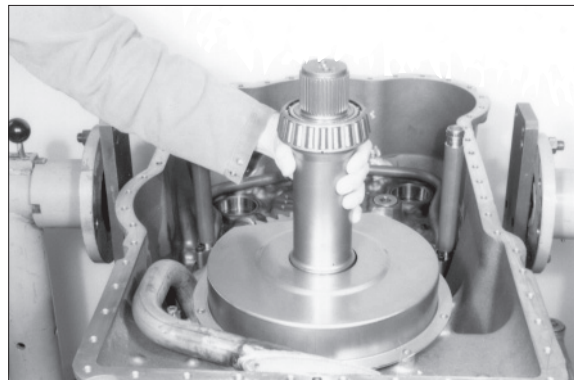

75773TM234

(7) Install preassembled drive shaft and clutches

- ① Insert all bearing outer races into the bearing bores of the housing cover.
- ※ At the use of already run bearings, pay attention to the allocation of the bearing outer races, see also note/page 3-86.

AN	Input
KV	Clutch-Forward
KR	Clutch-Reverse
K1	Clutch-1st speed
K2	Clutch-2nd speed
K3	Clutch-3rd speed
K4	Clutch-4th speed
AB	Output

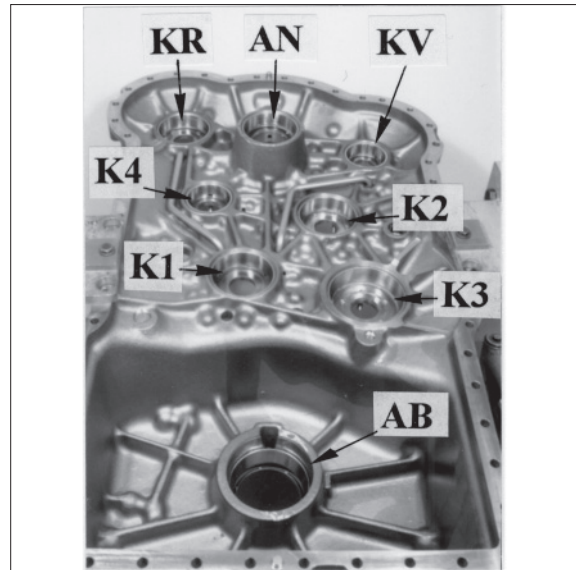

75773TM235

- ※ Prior to the installation of the clutches and the drive shaft, grease rectangular rings and align them centrally.
- ② Insert clutch KR, drive shaft and clutch KV together into the housing cover.

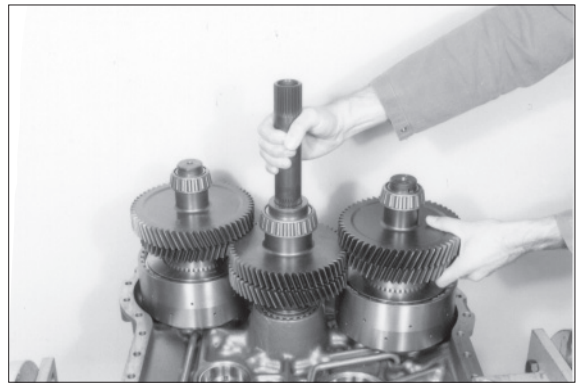

75773TM236

- ③ Lift drive gear and position clutch K4.



75773TM237

④ Install clutch K3.

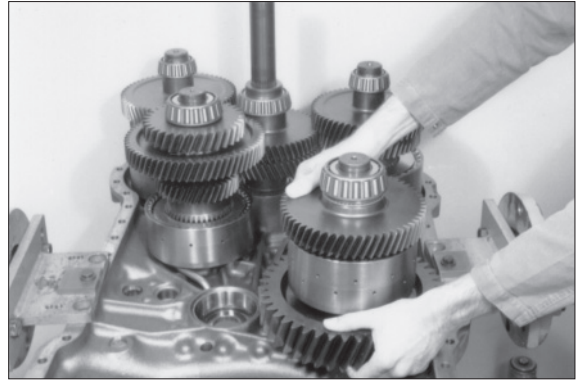

75773TM238

⑤ Position clutch K2.

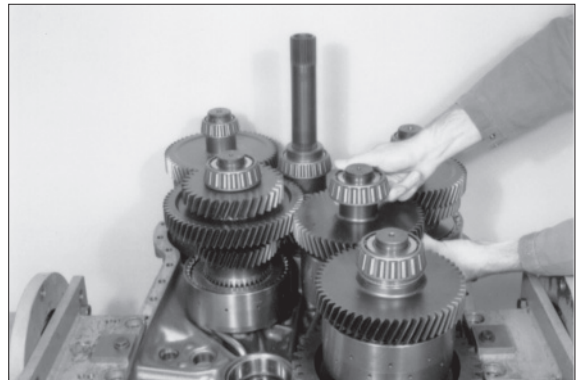

75773TM239

⑥ Lift clutch K4 and position clutch K1.

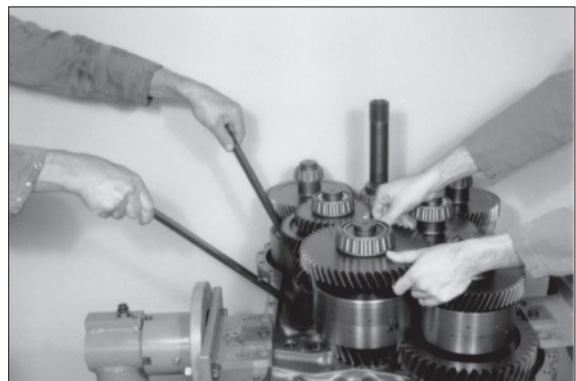

75773TM240

⑦ Illustration on the right shows the installation position of the single clutches in the housing cover. Grease rectangular rings (arrows) and align them centrally.

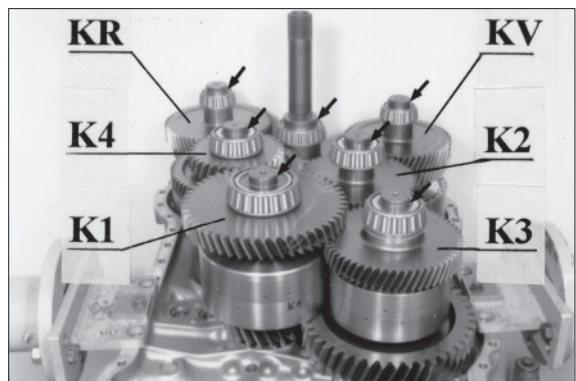

75773TM241

- ⑧ Fix all clutches by means of handles.
 Handle (6 pieces needed) 5870 260 010

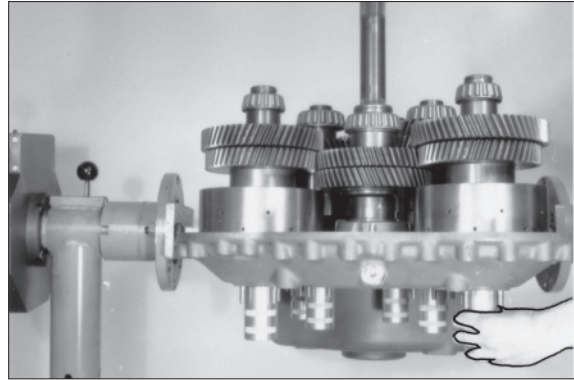

75773TM242

- ⑨ Tilt housing cover 180°.
 Install eye bolts (arrows).
 Eye bolt(M20, 2EA) 0636 804 003
 Eye bolt(M16, 1EA) 0636 804 001
 Puller device 5870 000 017

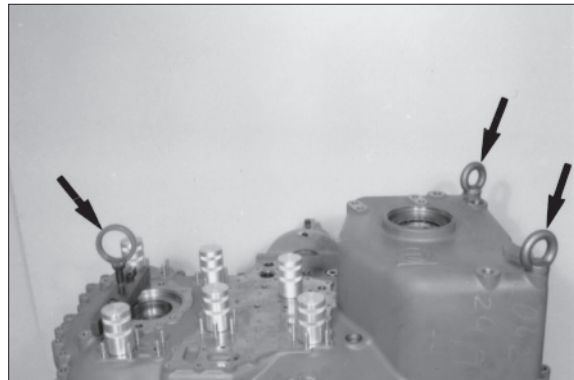

75773TM243

- ⑩ Grease O-rings of the two oil tubes.
 Wet mounting face with sealing compound loctite (type No.574).
 Position preassembled housing cover by means of lifting device carefully on the gearbox housing until contact is obtained.
 ※ Pay attention to the overlapping of the oil tubes with the bores in the housing cover.
 Lifting chain 5870 281 047



75773TM244

- ⑪ Remove handles again.

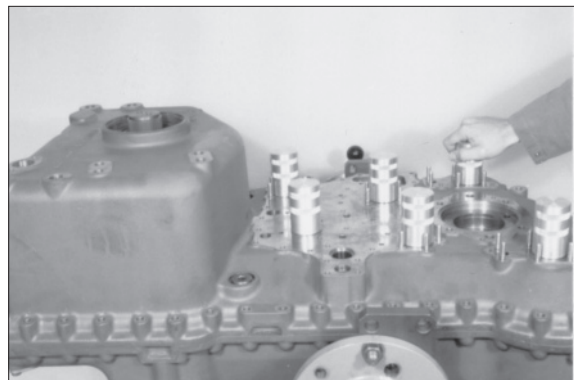

75773TM245

- ⑫ Install both cylindrical pins centrally to the housing face.

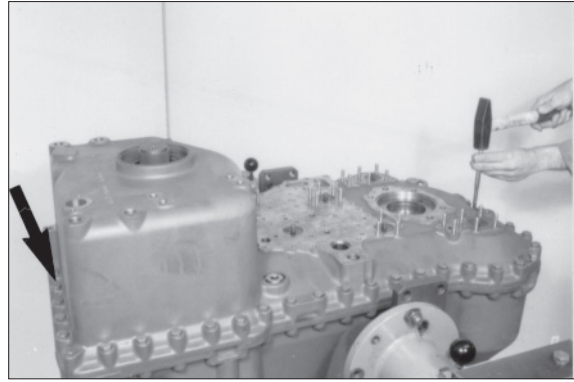

75773TM246

- ⑬ Fasten housing cover by means of hexagon head screws.
· Torque limit (M10/8.8) : 4.7 kgf · m
(33.9 lbf · ft)
※ Pay attention to position of the fixing plate, see Arrow.

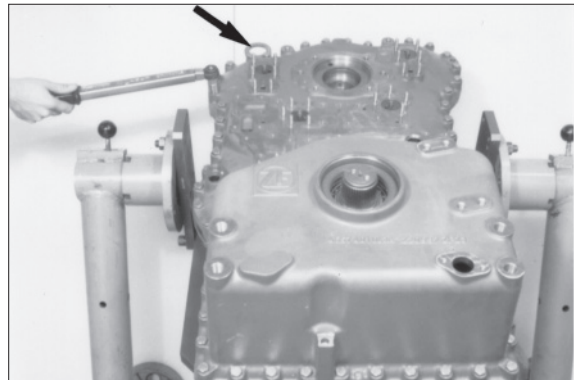

75773TM247

(8) Install pump shaft (power take off)

- ① Install ball bearing.
Squeeze rectangular ring in (arrow) and let it snap in.

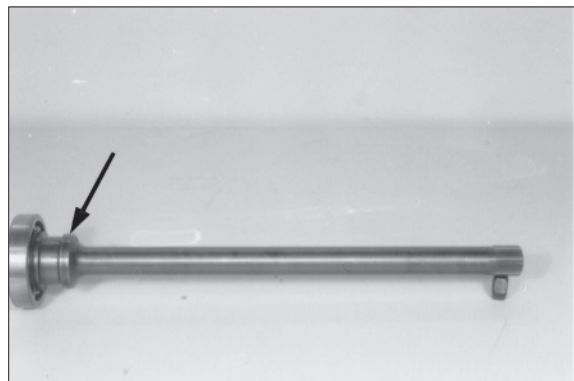

75773TM248

- ② Grease rectangular ring, align it centrally and introduce pump shaft until contact is obtained.

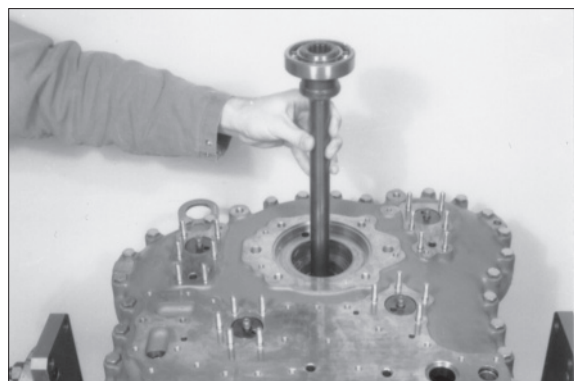

75773TM249

- ③ Fix pump shaft by means of circlip.

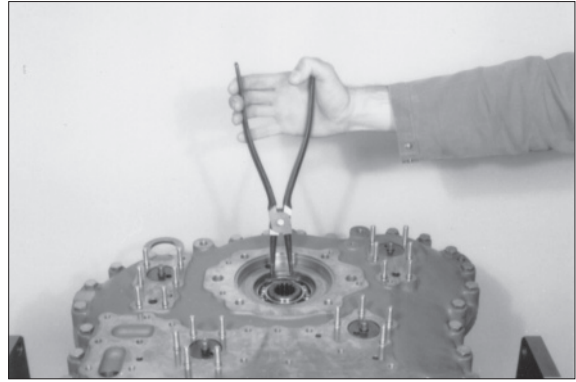

75773TM250

- ④ Insert O-ring (arrow) into the annular groove of the oil feed covers.

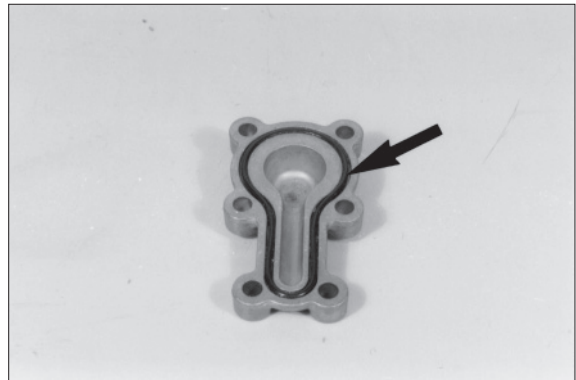

75773TM251

- ⑤ Fasten both covers (arrows) by means of hexagon nuts (use plain washers).
· Torque limit : 2.3 kgf · m (17.0 lbf · ft)

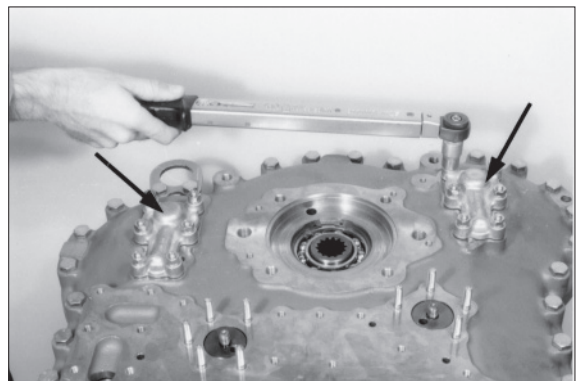

75773TM252

(9) Install output flanges

- ① Install shaft seal with the sealing lip facing the oil chamber.
※ At the use of the prescribed driver, the exact installation position is obtained.
Wet rubber coated outer diameter with spirit.
Grease sealing lip.
Driver 5870 048 213



75773TM255

- ② Assemble output flange.
Insert O-ring (arrow) into the gap of drive flange and shaft.

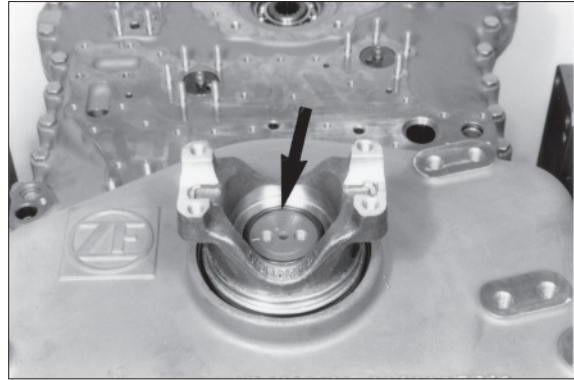

75773TM256

- ③ Fasten output flange by means of disk and hexagon head screws.
· Torque limit (M10/8.8) : 4.7 kgf · m
(33.9 lbf · ft)

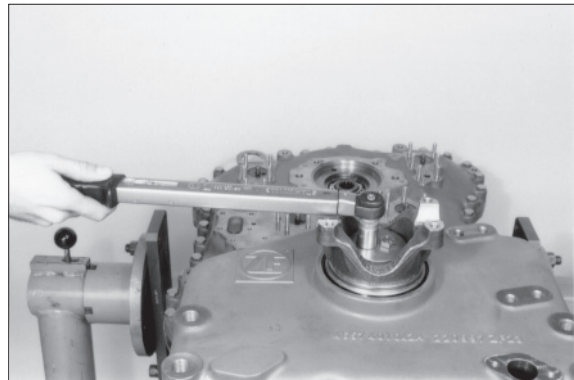

75773TM257

- ④ Fix hexagon head screws by means of lock plate.
Driver 5870 057 009
Handle 5870 260 002
Install converter side output flange accordingly.

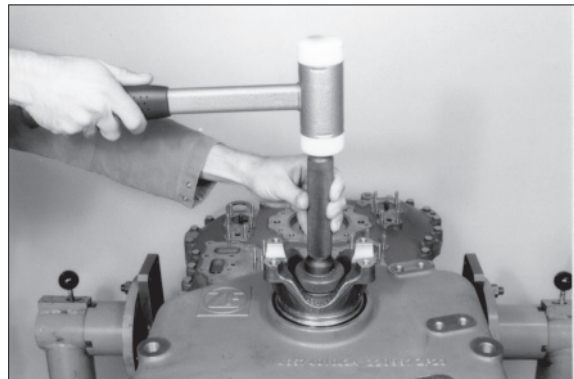

75773TM258

(10) Converter back pressure valve

- ① Illustration on the right shows the components of the converter back pressure valve.
- 1 Piston
 - 2 Compression spring
 - 3 Pressure plate
 - 4 Lock plate
- ※ Install pressure plate with the spigot (∅ 6 mm) facing the lock plate.

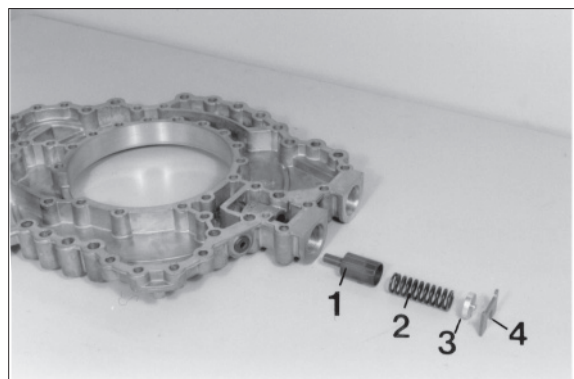

75773TM260

- ② Introduce components according to figure (10) ①, preload and fix by means of lock plate.

Equip plug (arrow) with new O-ring and install it.

- Torque limit(M14 × 1.5) : 2.5 kgf · m
(18.4 lbf · ft)

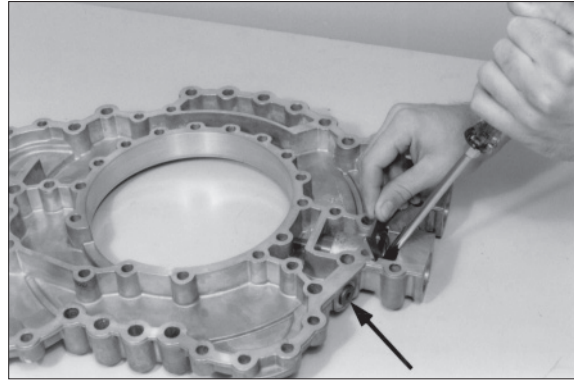

75773TM261

(11) Oil feed housing-Transmission pump

- ① Install two adjusting screws (arrows) and lay on gasket.

Adjusting screws (M8) 5870 204 011

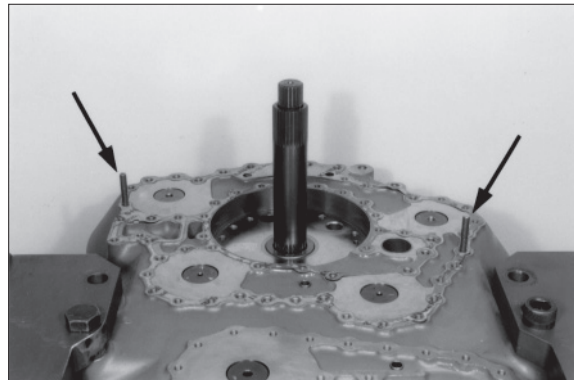

75773TM262

- ② Lay on oil feed housing and fix it provisionally by means of socket head screws.

- ※ Screw socket head screws only in until contact is obtained do not tighten.

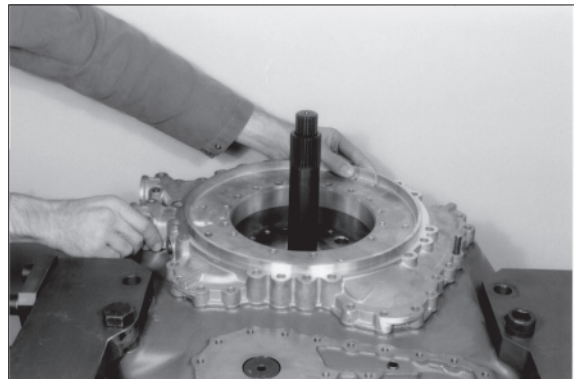

75773TM263

- ③ Install two adjusting screws and introduce stator shaft until contact is obtained.

- ※ Pay attention to the overlapping of the bores.

Adjusting screws (M10) 5870 204 007

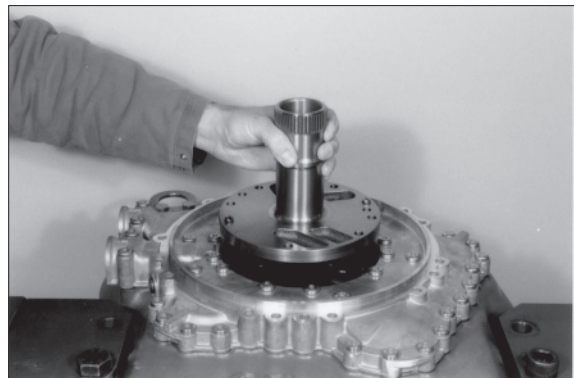

75773TM264

- ④ Insert O-ring (arrow) into the annular groove and oil it.



75773TM265

- ⑤ Introduce transmission pump (complete) and put it by means of socket head screws (for the moment without O-rings) evenly against shoulder.
Now, remove socket head screws again.

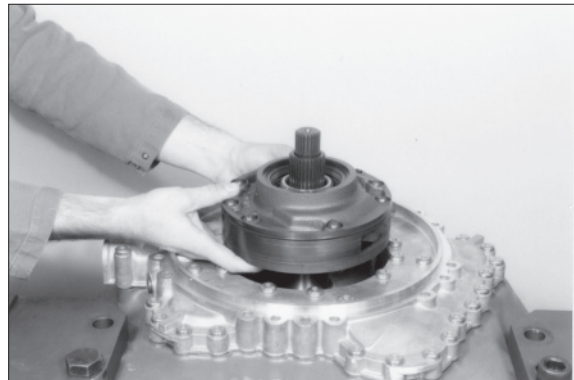

75773TM266

- ⑥ Equip socket head screws with new O-ring (arrow).
* Grease O-rings.

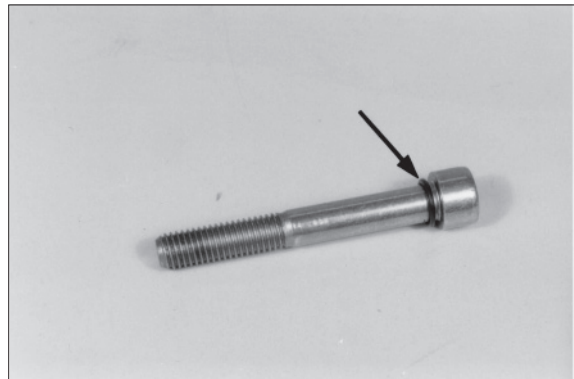

75773TM267

- ⑦ Fasten transmission pump by means of socket head screws.
· Torque limit : 4.7 kgf · m (33.9 lbf · ft)

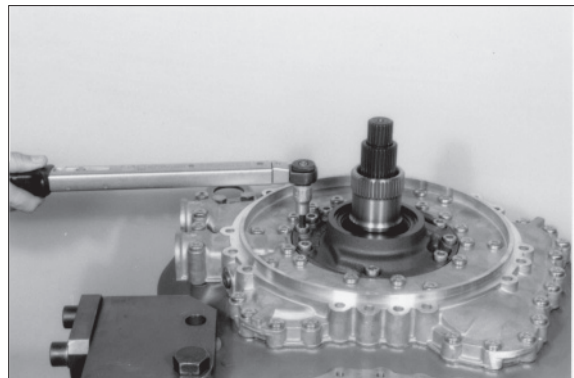

75773TM268

- ⑧ Fasten oil feed housing by means of socket head screws and hexagon head screws (2 pieces).

· Torque limit

- Socket head screw : 2.3 kgf · m (16.6 lbf · ft)

- Hexagon head screw : 4.7 kgf · m (33.9 lbf · ft)

- ※ Pay attention to the position of the fixing plate, see arrow.

Box spanner (Torx, TX-40) 5873 042 004

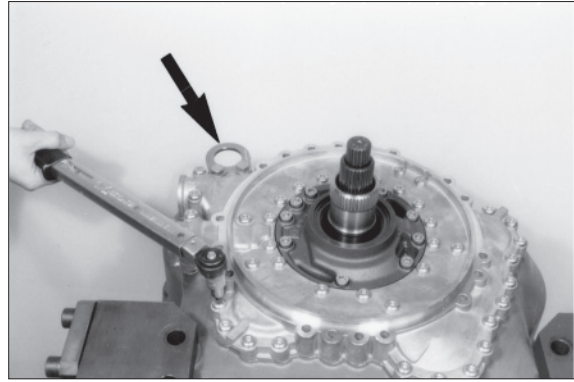

75773TM269

(12) Engine connection-Converter

- ① Fasten converter bell by means of hexagon head screws.

· Torque limit (M10/10.9) : 6.9 kgf · m

(50.1 lbf · ft)

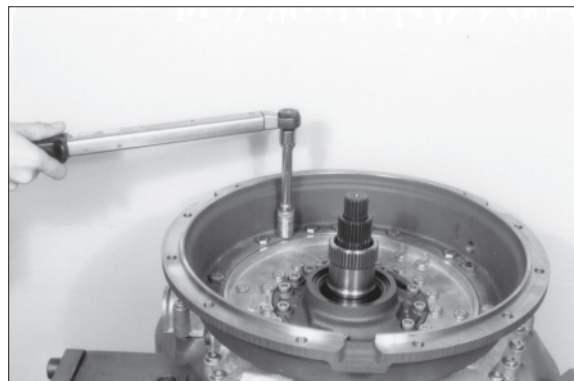

75773TM270

- ② Screw drive shaft and diaphragm together.

· Torque limit (M12/10.9) : 11.7 kgf · m

(84.8 lbf · ft)

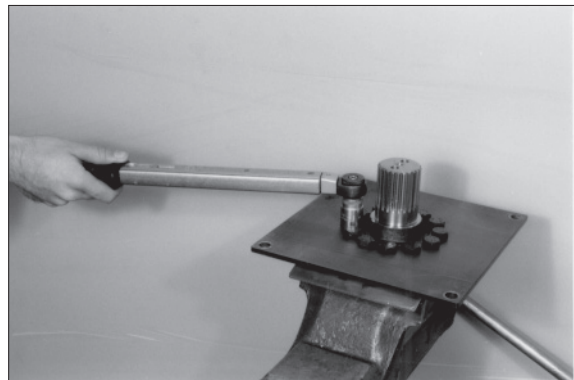

75773TM271

- ③ Fasten diaphragm by means of hexagon head screws on the converter.

· Torque limit (M12/10.9) : 11.7 kgf · m

(84.8 lbf · ft)

- ※ Insert hexagon head screws with loctite (type No.262).

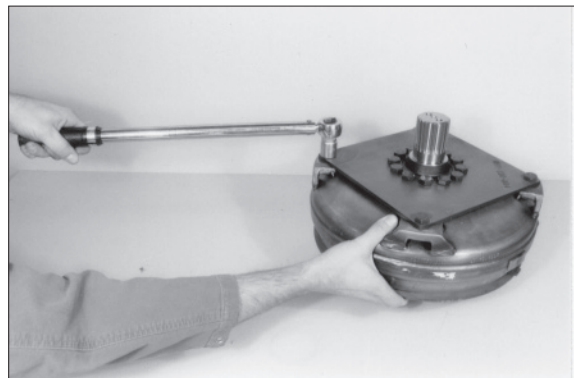

75773TM272

④ Introduce converter until contact is obtained.

- ※ Pulse disk of the converter must be positioned centrally to the bore of the inductive transmitter, see Arrow. Only in this way will be ensured that the converter is perfectly introduced.

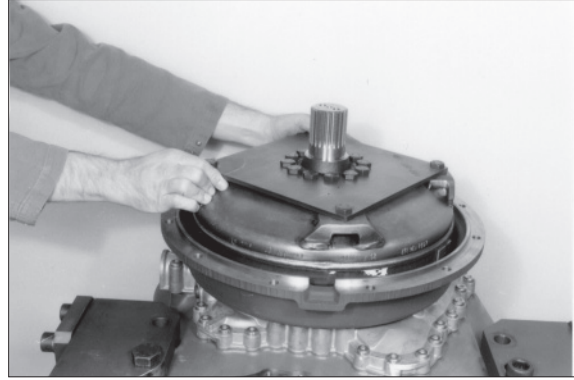

75773TM273

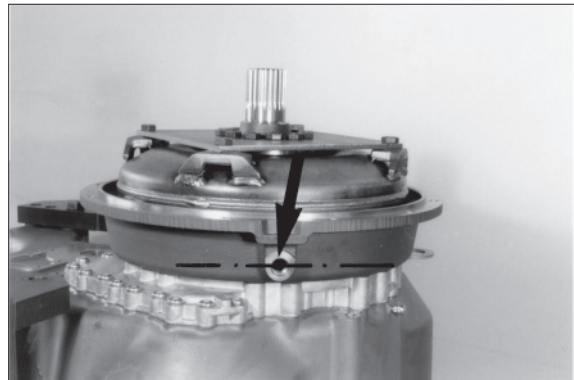

75773TM274

⑤ Insert ball bearing until contact is obtained and fix it by means of circlip.



75773TM275

⑥ Assemble housing cover.

Install drive flange, lay on disk an pull cover by means of hexagon head screws evenly against shoulder.

- Torque limit (M8/10.9) : 3.5 kgf · m
(25.1 lbf · ft)

- ※ Pay attention to the radial installation position of the cover, see figure.

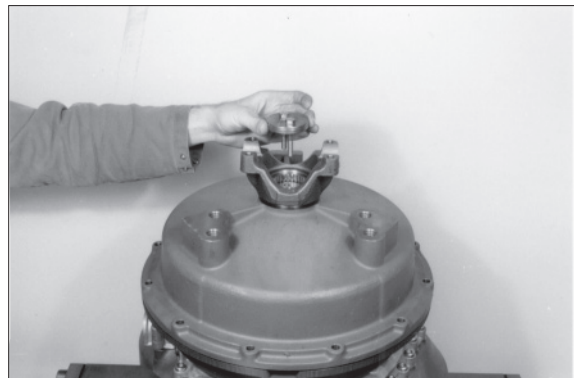

75773TM276

- ⑦ Fix hexagon head screws by means of lock plate.

Driver 5870 057 010

Handle 5870 260 002

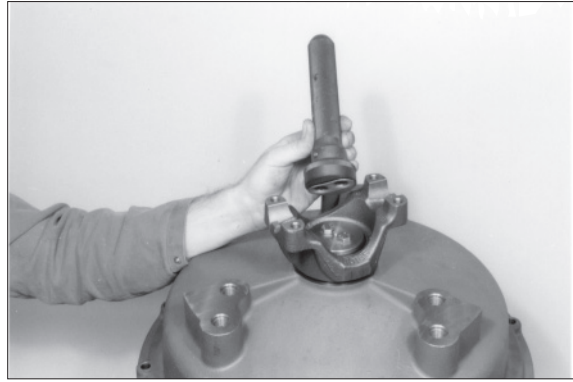

75773TM277

- ⑧ Fasten cover by means of hexagon head screws and nuts on the converter bell.

· Torque limit (M10/838) : 4.7 kgf · m
(33.9 lbf · ft)

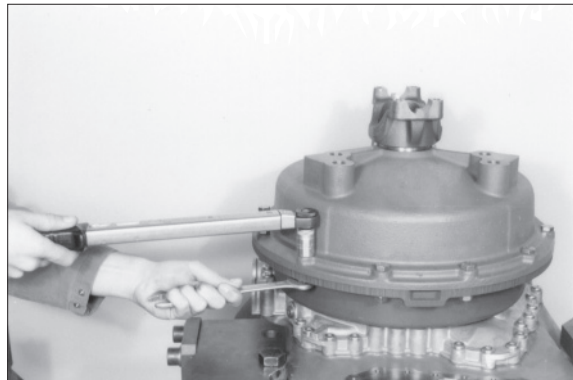

75773TM278

- ⑨ Mount gasket and fasten cover by means of hexagon head screws.

· Torque limit (M8/8.8) : 2.3 kgf · m
(17.0 lbf · ft)

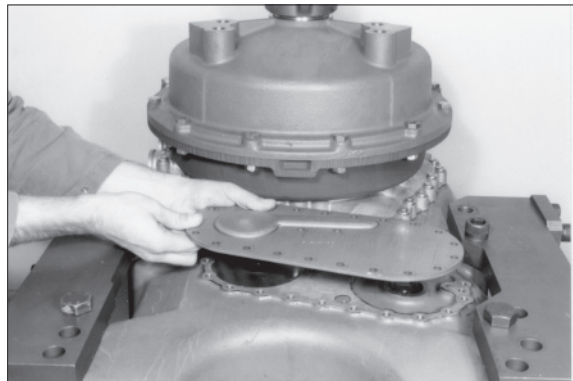

75773TM279

(13) Converter safety valve

- ① Insert converter safety valve (complete) into the housing hose.



75773TM280

(14) Mount duct plate and hydraulic control unit

① Install components according to the following draft.

· Torque limit (M8) : 2.3 kgf · m (17.0 lbf · ft)

※ Pay attention to the installation position of the different gaskets, see draft.

- 1 Gasket
- 2 Duct plate
- 3 Gasket
- 4 Intermediate plate
- 5 Gasket

Adjusting screws 5870 204 063
Box spanne 5873 042 004

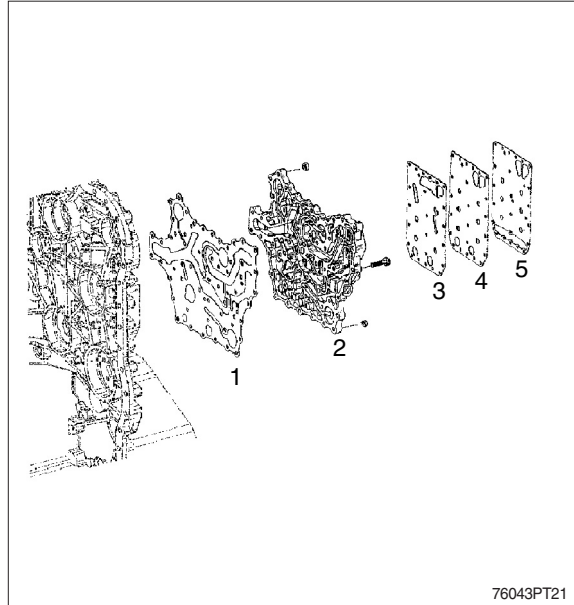

② Equip screw plug (arrow) with new O-ring and install it.

· Torque limit (M16 × 1.5) : 3.0 kgf · m
(21.7 lbf · ft)

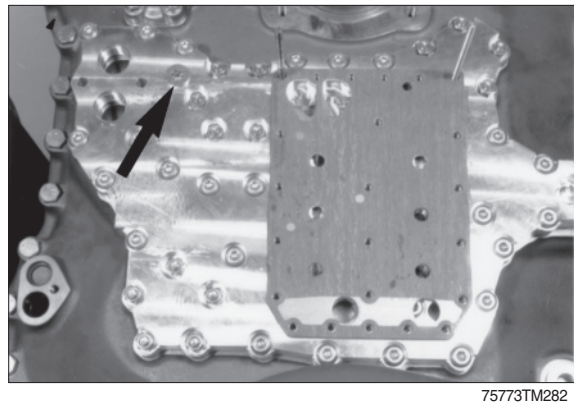

③ Fasten hydraulic control unit (HSG-94) by means of socket head screws.

· Torque limit (M6) : 0.97 kgf · m (7.0 lbf · ft)

Adjusting screws 5870 204 063
Box spanner (Torx Tx-27) 5873 042 002

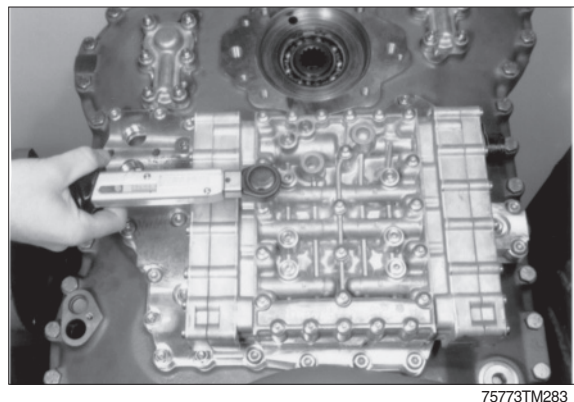

(15) Install plugs and oil level tube

① Equip both plugs (arrows) with new O-rings and install them.

- Torque limit (M18 × 1.5) : 5.1 kgf · m
(36.9 lbf · ft)
- Torque limit (M26 × 1.5) : 8.2 kgf · m
(59.0 lbf · ft)

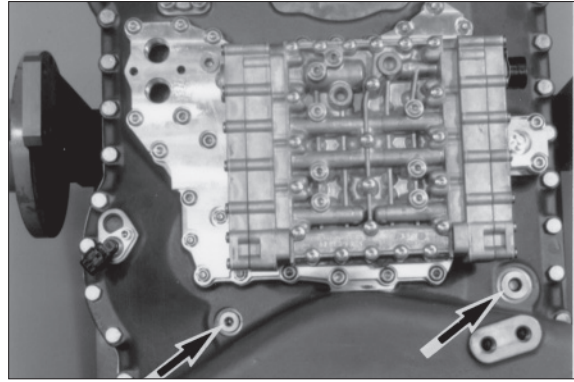

75773TM284

② Install oil level tube (arrow).

※ Mount new gasket.

- Torque limit (M8/10.9) : 3.5 kgf · m
(25.1 lbf · ft)

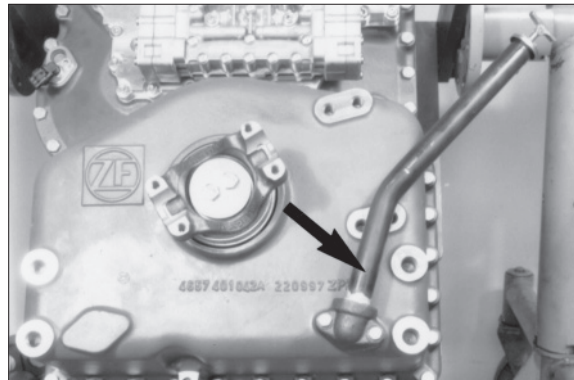

75773TM285

③ Install cover plate (arrow 1).

※ Install new gasket.

- Torque limit (M8/8.8) : 2.3 kgf · m
(17.0 lbf · ft)

Equip screw plug (arrow 2) with new O-ring and install it.

- Torque limit (M38 × 1.5) : 14.3 kgf · m
(103 lbf · ft)

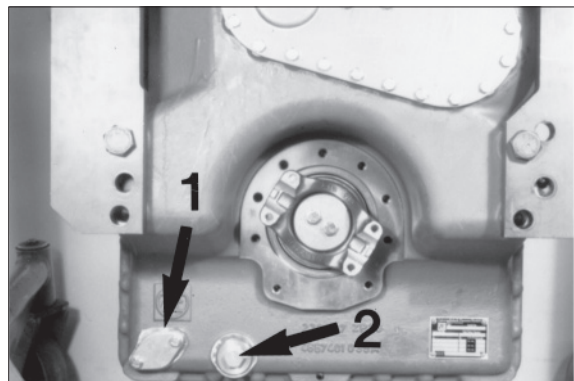

75773TM286

(16) Speed sensor and inductive transmitters

① The figures show the installation position of the single inductive transmitters and the speed sensor.

- 34 Speed sensor
n-Output and speedometer
- 21 Inductive transmitter
n-Turbine
- 47 Inductive transmitter
n-Central gear train
- 48 Inductive transmitter
n-Engine

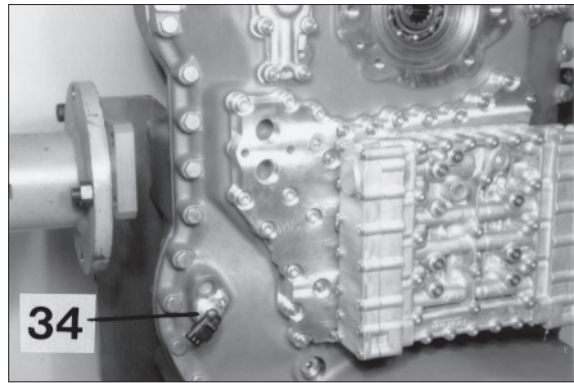

75773TM290

② Grease O-rings and install speed sensor as well as inductive transmitters.

- Torque limit : 2.3 kgf · m (17.0 lbf · ft)
(Socket head screw/Speed sensor)
- Torque limit : 3.1 kgf · m (22.1 lbf · ft)
(Inductive transmitter)

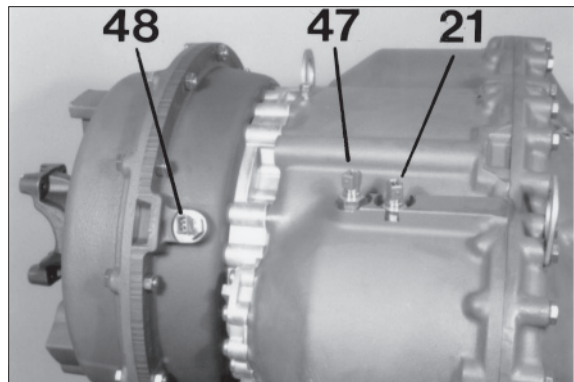

75773TM291

③ Install breather (arrow).

- Torque limit : 1.2 kgf · m (8.9 lbf · ft)

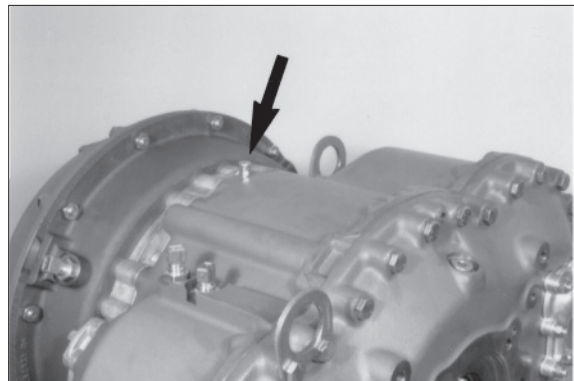

75773TM292