

## GROUP 2 SPECIFICATION

### 1. MAJOR COMPONENT

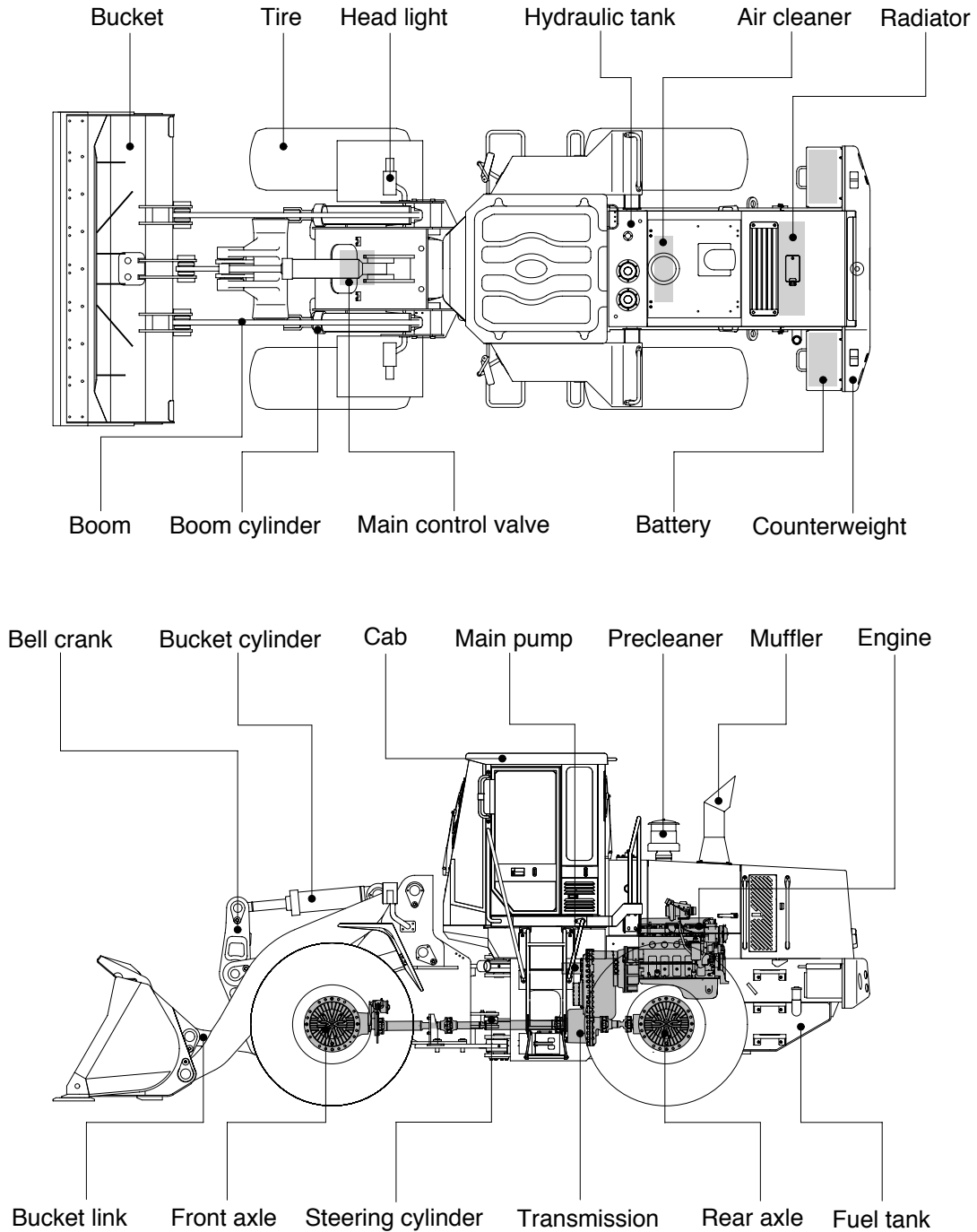

76072SE01

## 2. SPECIFICATIONS

### 1) WITHOUT TOOTH AND CUTTING EDGE TYPE BUCKET

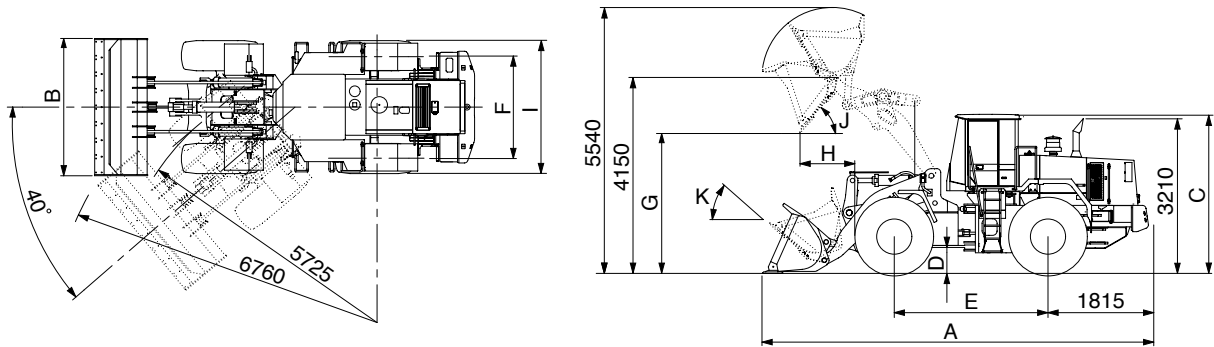

76072SE02

Description		Unit	Specification	
Operating weight		kg(lb)	17660(38930)	
Bucket capacity	Struck	m <sup>3</sup> (yd <sup>3</sup> )	2.6(3.4)	
	Heaped		3.0(3.9)	
Overall length	A	mm(ft-in)	7960(26' 1")	
Overall width	B		2900( 9' 6")	
Overall height	C		3440(11' 3")	
Ground clearance	D		420( 1' 5")	
Wheelbase	E		3300(10'10")	
Tread	F		2160( 7' 1")	
Dump clearance at 45°	G		3075(10' 1")	
Dump reach(Full lift)	H		1155( 3'10")	
Width over tires	I		2770( 9' 1")	
Dump angle	J		Degree (°)	47
Roll back angle(Carry position)	K			47
Cycle time	Lift(With load)		sec	6.2
	Dump(With load)			1.3
	Lower(Empty)	3.0		
Maximum travel speed		km/hr(mph)	36.4(22.7)	
Braking distance		m(ft-in)	11(36' 1")	
Minimum turning radius(Center of outside tire)			5.73(18' 9")	
Gradability		Degree (°)	30	
Travel speed	Forward	First gear	7.6(4.7)	
		Second gear	12.8(8.0)	
		Third gear	23.6(14.7)	
		Fourth gear	36.4(22.7)	
	Reverse	First gear	8.0(5.0)	
		Second gear	13.5(8.4)	
Third gear		24.7(15.4)		

## 2) WITH BOLT-ON CUTTING EDGE TYPE BUCKET

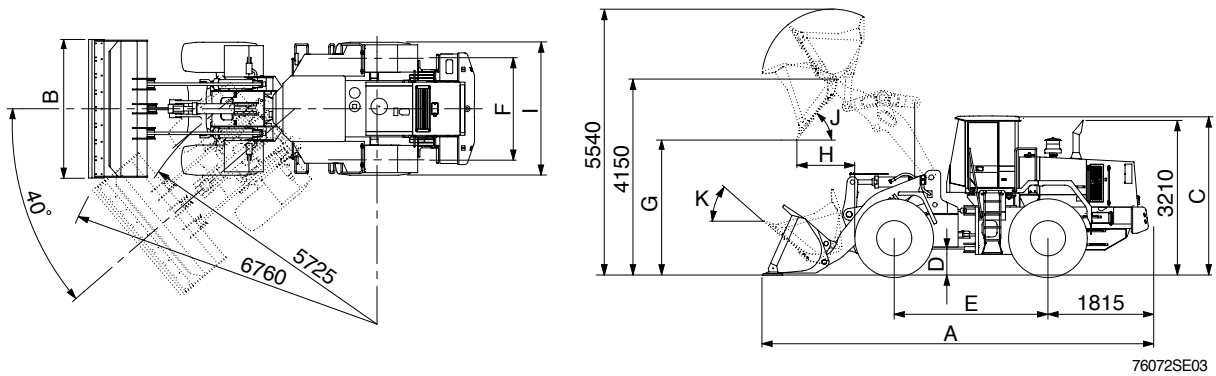

Description		Unit	Specification	
Operating weight		kg(lb)	17900(39460)	
Bucket capacity	Struck	m <sup>3</sup> (yd <sup>3</sup> )	2.7(3.5)	
	Heaped		3.1(4.1)	
Overall length	A	mm(ft-in)	8060(26' 5")	
Overall width	B		2900( 9' 6")	
Overall height	C		3440(11' 3")	
Ground clearance	D		420( 1' 5")	
Wheelbase	E		3300(10'10")	
Tread	F		2160( 7' 1")	
Dump clearance at 45°	G		3000( 9'10")	
Dump reach(Full lift)	H		1190( 3'11")	
Width over tires	I		2770( 9' 1")	
Dump angle	J		Degree (°)	47
Roll back angle(Carry position)	K			47
Cycle time	Lift(With load)	sec	6.2	
	Dump(With load)		1.3	
	Lower(Empty)		3.0	
Maximum travel speed		km/hr(mph)	36.4(22.7)	
Braking distance		m(ft-in)	11(36' 1")	
Minimum turning radius(Center of outside tire)			5.73(18' 9")	
Gradability		Degree (°)	30	
Travel speed	Forward	First gear	7.6(4.7)	
		Second gear	12.8(8.0)	
		Third gear	23.6(14.7)	
		Fourth gear	36.4(22.7)	
	Reverse	First gear	8.0(5.0)	
		Second gear	13.5(8.4)	
Third gear		24.7(15.4)		

### 3) WITH TOOTH TYPE BUCKET

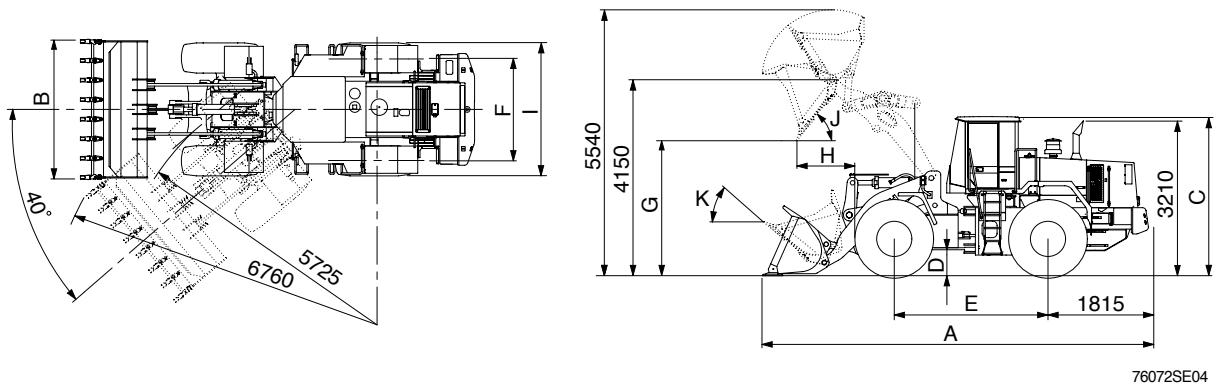

Description		Unit	Specification	
Operating weight		kg(lb)	17820(39290)	
Bucket capacity	Struck	m <sup>3</sup> (yd <sup>3</sup> )	2.6(3.4)	
	Heaped		3.0(3.9)	
Overall length	A	mm(ft-in)	8180(26'10")	
Overall width	B		2950( 9' 8")	
Overall height	C		3440(11' 3")	
Ground clearance	D		420( 1' 5")	
Wheelbase	E		3300(10'10")	
Tread	F		2160( 7' 1")	
Dump clearance at 45°	G		2870( 9' 5")	
Dump reach(Full lift)	H		1270( 4' 2")	
Width over tires	I		2770( 9' 1")	
Dump angle	J		Degree (°)	47
Roll back angle(Carry position)	K			47
Cycle time	Lift(With load)	sec	6.2	
	Dump(With load)		1.3	
	Lower(Empty)		3.0	
Maximum travel speed		km/hr(mph)	36.4(22.7)	
Braking distance		m(ft-in)	11(36' 1")	
Minimum turning radius(Center of outside tire)			5.73(18' 9")	
Gradability		Degree (°)	30	
Travel speed	Forward	First gear	7.6(4.7)	
		Second gear	12.8(8.0)	
		Third gear	23.6(14.7)	
		Fourth gear	36.4(22.7)	
	Reverse	First gear	8.0(5.0)	
		Second gear	13.5(8.4)	
Third gear		24.7(15.4)		

### 3. WEIGHT

Item	kg	lb
Front frame assembly	1631	3596
Rear frame assembly	1962	4326
Front fender(LH & RH)	28	62
Counterweight	1050	2315
Cab assembly	1000	2205
Engine assembly	459	1012
Transmission assembly	470	1036
Drive shaft(Front)	44	97
Drive shaft(Center)	46	101
Drive shaft(Rear)	27	60
Front axle(Include differential)	970	2139
Rear axle(Include differential)	840	1852
Tire(23.5-25, 20PR, L3)	300	661
Hydraulic tank assembly	210	463
Fuel tank assembly	368	811
Main pump assembly	37	82
Fan & brake pump assembly	7	15
Main control valve	51	112
Flow amplifier valve	15	33
Boom assembly	1200	2646
Bell crank assembly	360	794
Bucket link	57	126
3.1m <sup>3</sup> bucket, with bolt on cutting edge	1675	3693
3.0m <sup>3</sup> bucket, with tooth	1625	3583
3.0m <sup>3</sup> bucket, without tooth and cutting edge	1415	3120
Boom cylinder assembly	158	348
Bucket cylinder assembly	184	406
Steering cylinder assembly	29	64
Seat	40	88
Battery	55	121

#### 4. SPECIFICATION FOR MAJOR COMPONENTS

##### 1) ENGINE

Item	Specification
Model	Cummins QSB5.9
Type	4-cycle turbocharged, charge air cooled diesel engine
Control type	Electronic control
Cooling method	Water cooling
Number of cylinders and arrangement	6 cylinders, in-line
Firing order	1-5-3-6-2-4
Combustion chamber type	Direct injection type
Cylinder bore x stroke	102 x 120mm(4.02" x 4.72")
Piston displacement	5880cc(359cu in)
Compression ratio	16.3 : 1
Rated gross horse power	218ps at 2200rpm
Maximum gross torque at 1400rpm	96kgf · m(694lbf · ft)
Engine oil quantity	16 (4.2 U.S. gal)
Wet weight	459kg(1012lb)
High idling speed	2370 ± 50rpm
Low idling speed	900 ± 50rpm
Rated fuel consumption	155g/ps · hr
Starting motor	Nippondenso 228000-7902 (24V)
Alternator	Delco Remy 22SI(24V-70Amp)
Battery	2 x 12V x 160Ah

## 2) MAIN PUMP

Item	Specification
Type	Fixed displacement tandem gear pump
Capacity	68+63cc/rev
Maximum operating pressure	210kgf/cm <sup>2</sup> (2990psi)
Rated oil quantity	283 l /min(74.8U.S.gpm / 62.0U.K.gpm)
Rated speed	2200rpm

## 3) FAN PUMP + BRAKE

Item	Specification	
	FAN	BRAKE
Type	Fixed displacement double helical gear pump	
Capacity	22.9cc/rev	11.9cc/rev
Maximum operating pressure	120kgf/cm <sup>2</sup> (1710psi)	150kgf/cm <sup>2</sup> (2130psi)
Rated oil quantity	48 l /min(12.7U.S.gpm)	25 l /min(6.6U.S.gpm)
Rated speed	2200rpm	

## 4) MAIN CONTROL VALVE

Item	Specification
Type	2 spool
Operating method	Hydraulic pilot assist
Main relief valve pressure	210kgf/cm <sup>2</sup> (2990psi)
Overload relief valve pressure(Boom)	240kgf/cm <sup>2</sup> (3410psi)

## 5) REMOTE CONTROL VALVE

Item	Specification	
Type	Pressure reducing type	
Operating	Minimum	5.8kgf/cm <sup>2</sup> (82.5psi)
	Maximum	19kgf/cm <sup>2</sup> (270psi)
Single operation stroke	Lever	70mm(2.8in)

## 6) CYLINDER

Item		Specification
Boom cylinder	Bore dia x Rod dia x Stroke	Ø 160 x Ø90 x 757mm
Bucket cylinder	Bore dia x Rod dia x Stroke	Ø 180 x Ø90 x 530mm
Steering cylinder	Bore dia x Rod dia x Stroke	Ø 80 x Ø45 x 440mm

## 7) DYNAMIC POWER TRANSMISSION DEVICES

Item		Specification	
Transmission	Model	4WG210	
	Type	Converter	Single-stage, single-phase
		Transmission	Full-automatic power shift
	Gear shift	Forward fourth gear, reverse third gear	
	Adjustment	Electrical single lever type, kick-down system.	
Axle	Drive devices	4-wheel drive	
	Front	Front fixed location	
	Rear	Oscillation 12. of center pin-loaded	
Wheels	Tires	23.5-25, 20PR(L3)	
Brakes	Travel	Four-wheel, wet-disc type, full hydraulic	
	Parking	Spring applied, hydraulic released brake on front axle	
Steering	Type	Full hydraulic, articulated	
	Steering angle	40. to both right and left angle, respectively	



## 5. TIGHTENING TORQUE OF MAJOR COMPONENT

No	Items	Size	kgf · m	lbf · ft	
1	Engine	Engine mounting bolt(2EA)	M20 × 2.5	57.9 ± 8.7	419 ± 62.9
2		Engine mounting bolt(Bracket)	M12 × 1.75	10.7 ± 1.6	77.4 ± 11.6
3		Radiator mounting bolt	M16 × 2.0	29.7 ± 4.5	215 ± 32.5
4		Fuel tank mounting bolt	M16 × 2.0	29.7 ± 4.5	215 ± 32.5
5		Air cleaner mounting bolt	M10 × 1.5	6.9 ± 1.4	50.0 ± 10.1
6	Hydraulic system	Main pump housing mounting bolt	M12 × 1.75	12.8 ± 3.0	92.6 ± 21.7
7		Main control valve mounting bolt	M12 × 1.75	12.8 ± 3.0	92.6 ± 21.7
8		Steering unit mounting bolt	M10 × 1.5	6.9 ± 1.4	49.9 ± 10.1
9		Flow amplifier valve mounting bolt	M 8 × 1.25	2.5 ± 0.5	18.1 ± 3.6
10		Brake valve mounting bolt	M 8 × 1.25	2.5 ± 0.5	18.1 ± 3.6
11		Fan and brake pump mounting bolt	M10 × 1.5	6.9 ± 1.4	49.9 ± 10.1
12		Cut-off valve mounting bolt	M12 × 1.75	12.8 ± 3.0	92.6 ± 21.7
13		Remote control lever mounting bolt	M 6 × 1.0	1.1 ± 0.2	8.0 ± 1.4
14		Pilot supply unit mounting bolt	M 8 × 1.25	2.5 ± 0.5	18.1 ± 3.6
15		Safety valve	M 8 × 1.25	2.5 ± 0.5	18.1 ± 3.6
16		Hydraulic oil tank mounting bolt	M16 × 2.0	29.7 ± 4.5	215 ± 32.5
17	Power train system	Transmission mounting bolt	M24 × 3.0	100 ± 15	723 ± 109
18		Transmission mounting bolt(Bracket)	M20 × 2.5	46.3 ± 7.0	335 ± 50.6
19		Torque converter housing mounting bolt	M10 × 1.5	4.6 ± 0.7	33.3 ± 5.1
20		Front axle mounting bolt, nut	M24 × 2.0	100 ± 15	723 ± 109
21		Rear axle support mounting bolt, nut	M36 × 3.0	308 ± 46.2	2228 ± 334
22		Tire mounting nut	M22 × 1.5	61 ± 2.0	441 ± 14.5
23		Drive shaft joint mounting bolt	1/2-20UNF	15.5 ± 0.5	112 ± 3.6
24	Others	Counterweight mounting bolt	M30 × 2.0	199 ± 29.9	1439 ± 216
25		Operator's seat mounting bolt	M 8 × 1.25	3.4 ± 0.8	24.6 ± 5
26		ROPS Cab mounting bolt(4EA)	M27 × 2.0	124	900

## 6. TORQUE CHART

Use following table for unspecified torque.

### 1) BOLT AND NUT

#### (1) Coarse thread

Bolt size	8T		10T	
	kgf · m	lbf · ft	kgf · m	lbf · ft
M 6 × 1.0	0.85 ~ 1.25	6.15 ~ 9.04	1.14 ~ 1.74	8.2 ~ 12.6
M 8 × 1.25	2.0 ~ 3.0	14.5 ~ 21.7	2.73 ~ 4.12	19.7 ~ 29.8
M10 × 1.5	4.0 ~ 6.0	28.9 ~ 43.4	5.5 ~ 8.3	39.8 ~ 60
M12 × 1.75	7.4 ~ 11.2	53.5 ~ 79.5	9.8 ~ 15.8	71 ~ 114
M14 × 2.0	12.2 ~ 16.6	88.2 ~ 120	16.7 ~ 22.5	121 ~ 167
M16 × 2.0	18.6 ~ 25.2	135 ~ 182	25.2 ~ 34.2	182 ~ 247
M18 × 2.5	25.8 ~ 35.0	187 ~ 253	35.1 ~ 47.5	254 ~ 343
M20 × 2.5	36.2 ~ 49.0	262 ~ 354	49.2 ~ 66.6	356 ~ 482
M22 × 2.5	48.3 ~ 63.3	350 ~ 457	65.8 ~ 98.0	476 ~ 709
M24 × 3.0	62.5 ~ 84.5	452 ~ 611	85.0 ~ 115	615 ~ 832
M30 × 3.5	124 ~ 168	898 ~ 1214	169 ~ 229	1223 ~ 1655
M36 × 4.0	174 ~ 236	1261 ~ 1703	250 ~ 310	1808 ~ 2242

#### (2) Fine thread

Bolt size	8T		10T	
	kgf · m	lbf · ft	kgf · m	lbf · ft
M 8 × 1.0	2.17 ~ 3.37	15.7 ~ 24.3	3.04 ~ 4.44	22.0 ~ 32.0
M10 × 1.25	4.46 ~ 6.66	32.3 ~ 48.2	5.93 ~ 8.93	42.9 ~ 64.6
M12 × 1.25	7.78 ~ 11.58	76.3 ~ 83.7	10.6 ~ 16.0	76.6 ~ 115
M14 × 1.5	13.3 ~ 18.1	96.2 ~ 130	17.9 ~ 24.1	130 ~ 174
M16 × 1.5	19.9 ~ 26.9	144 ~ 194	26.6 ~ 36.0	193 ~ 260
M18 × 1.5	28.6 ~ 43.6	207 ~ 315	38.4 ~ 52.0	278 ~ 376
M20 × 1.5	40.0 ~ 54.0	289 ~ 390	53.4 ~ 72.2	386 ~ 522
M22 × 1.5	52.7 ~ 71.3	381 ~ 515	70.7 ~ 95.7	512 ~ 692
M24 × 2.0	67.9 ~ 91.9	491 ~ 664	90.9 ~ 123	658 ~ 890
M30 × 2.0	137 ~ 185	990 ~ 1338	182 ~ 248	1314 ~ 1795
M36 × 3.0	192 ~ 260	1389 ~ 1879	262 ~ 354	1893 ~ 2561

## 2) PIPE AND HOSE

Thread size	Width across flat(mm)	kgf · m	lbf · ft
1/4"	19	3	21.7
3/8"	22	4	28.9
1/2"	27	5	36.2
3/4"	36	12	86.8
1"	41	14	101

## 3) FITTING

Thread size	Width across flat(mm)	kgf · m	lbf · ft
1/4"	19	4	28.9
3/8"	22	5	36.2
1/2"	27	6	43.4
3/4"	36	13	94.0
1"	41	15	109

## 7. RECOMMENDED LUBRICANTS

Use only oils listed below or equivalent.

Do not mix different brand oil.

Service point	Kind of fluid	Capacity (U.S. gal)	Ambient temperature °C( °F)						
			-20 (-4)	-10 (14)	0 (32)	10 (50)	20 (68)	30 (86)	40 (104)
Engine oil pan	Engine oil	16(4.2)	SAE 30						
			SAE 10W						
			SAE 10W-30						
			SAE 15W-40						
Transmission	Oil	32(8.5)	SAE 10W-30						
			SAE 15W-40						
Axle	Gear oil	Front : 62(16.4) Rear : 42(11.1)	SAE 80W-90LSD/API GL-5						
Hydraulic tank	Hydraulic oil	Tank: 115(30.4) System: 260(69)	ISO VG 32						
			ISO VG 46						
			ISO VG 68						
Fuel tank	Diesel fuel	355(93.8)	ASTM D975 NO. 1						
			ASTM D975 NO. 2						
Fitting (Grease nipple)	Grease	As required	NLGI NO. 1						
			NLGI NO. 2						
Radiator	Mixture of antifreeze and water 50 : 50	39(10.3)	Ethylene glycol base permanent type						