

## GROUP 3 ENGINE SPEED & STALL RPM

### 1. TEST CONDITION

- 1) Normal temperature of the whole system
  - Coolant : Approx 80°C (176°F)
  - Hydraulic oil : 45 ± 5°C (113 ± 10°F)
  - Transmission oil : 75 ± 5°C (167 ± 10°F)
- 2) Normal operating pressure : See page 6-60.

### 2. SPECIFICATION

Engine speed, rpm					Remark
Low idle	High idle	Pump stall	Converter stall	Full stall	
800±25	2230±50	2200±70	1890±70	1820±100	

### 3. ENGINE RPM CHECK

Remark : If the checked data is not normal, it indicates that the related system is not working properly. Therefore, it is required to check the related system pressure : See page 6-60.

#### 1) Pump stall rpm

- Start the engine and raise the bucket approx 45 cm (1.5 ft) as the figure.
- Press the accelerator pedal fully and operate the bucket control lever to the retract position fully.
- Check the engine rpm at the above condition.

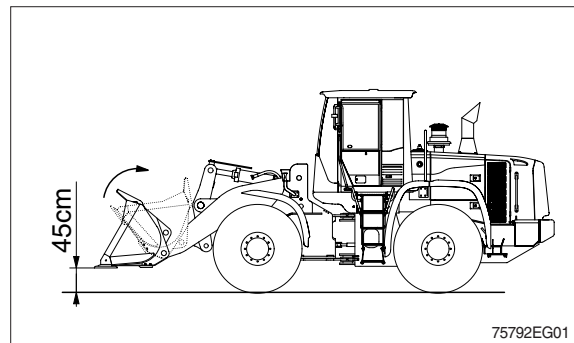

#### 2) Converter stall rpm

- Start the engine and lower the bucket on the ground as the figure.
- Set the clutch cut off mode switch at the OFF position.
- Press the brake pedal and accelerator pedal fully.
- Shift the transmission lever to the 4th forward position.
- Check the engine rpm at the above condition.

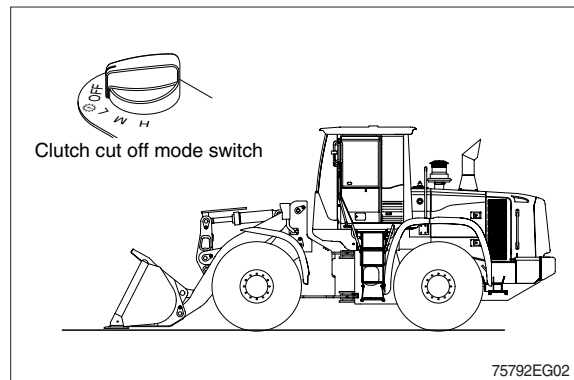

#### 3) Full stall rpm

- Start the engine and raise the bucket approx 45 cm (1.5 ft) as the figure.
- Set the clutch cut off mode switch at the OFF position.
- Press the brake pedal and accelerator pedal fully .
- Shift the transmission lever to the 4th forward position and operate the bucket lever to the retract position fully.
- Check the engine rpm at the above condition.

