

## GROUP 2 SPECIFICATION

### 1. MAJOR COMPONENT(HL757-7A, HL757XTD-7A)

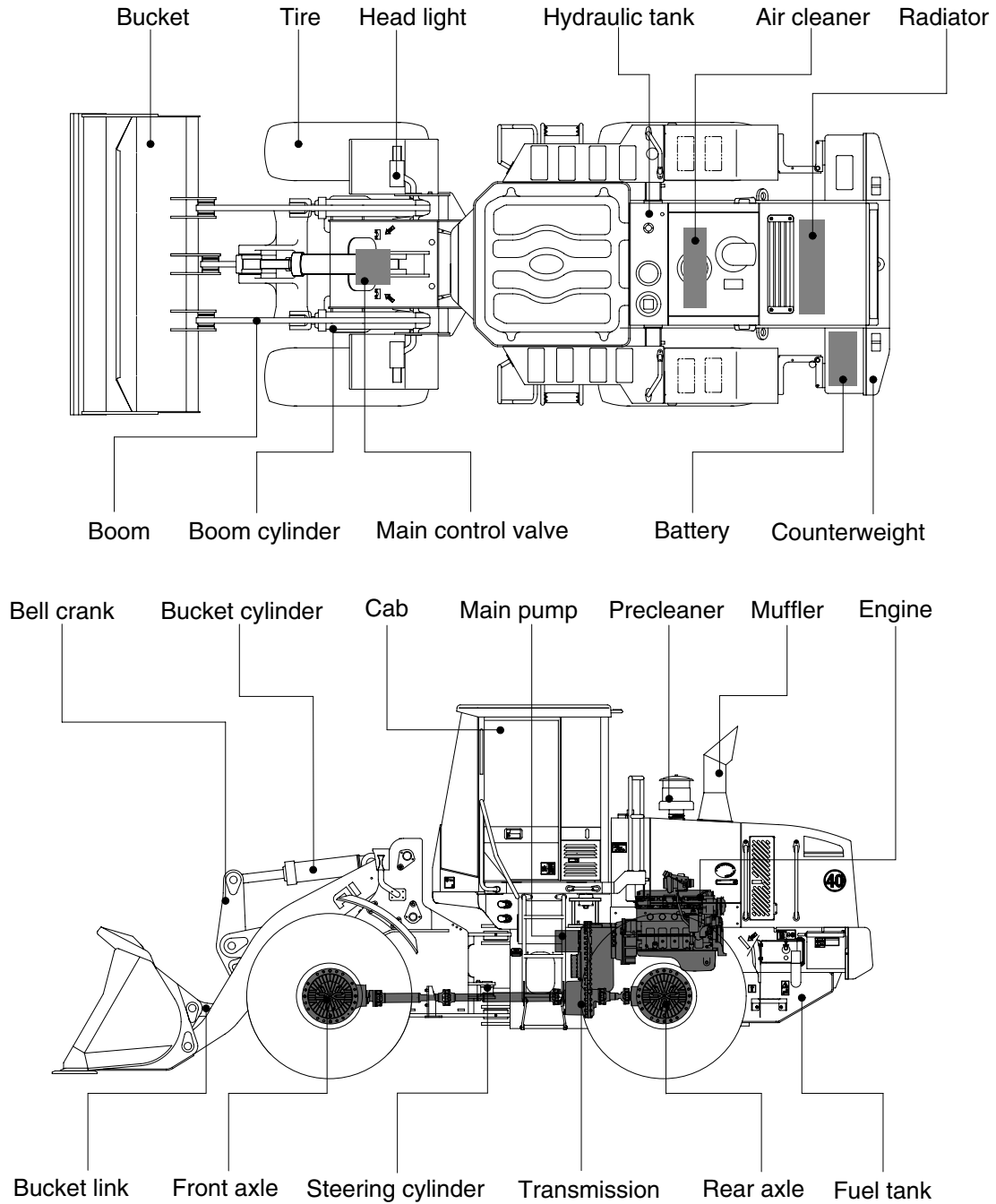

7577A2SE01

# MAJOR COMPONENT(HL757TM-7A)

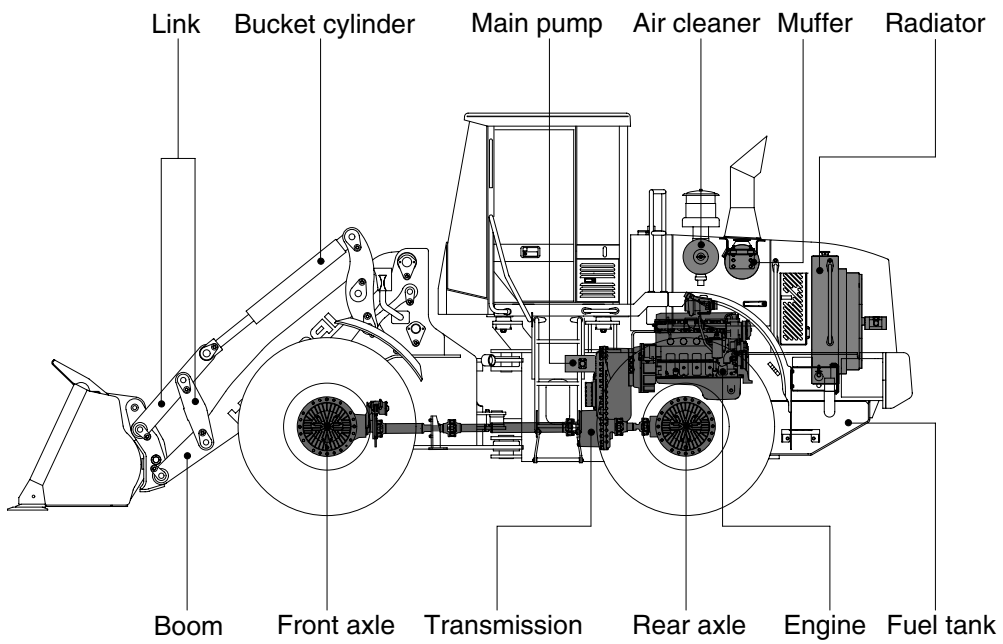
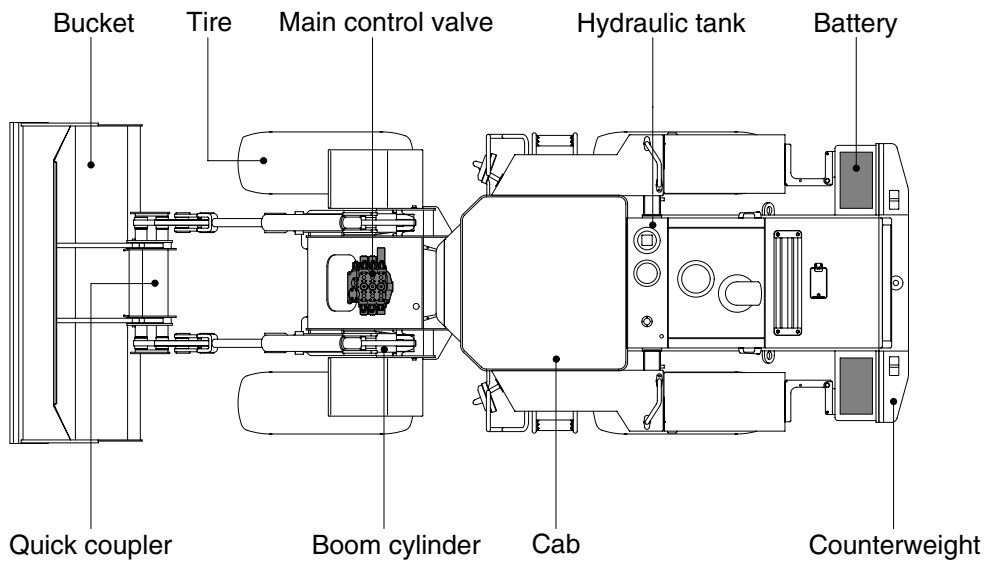

757TM7SE01

## 2. SPECIFICATIONS

### 1) WITH BOLT-ON CUTTING EDGE TYPE BUCKET(HL757-7A)

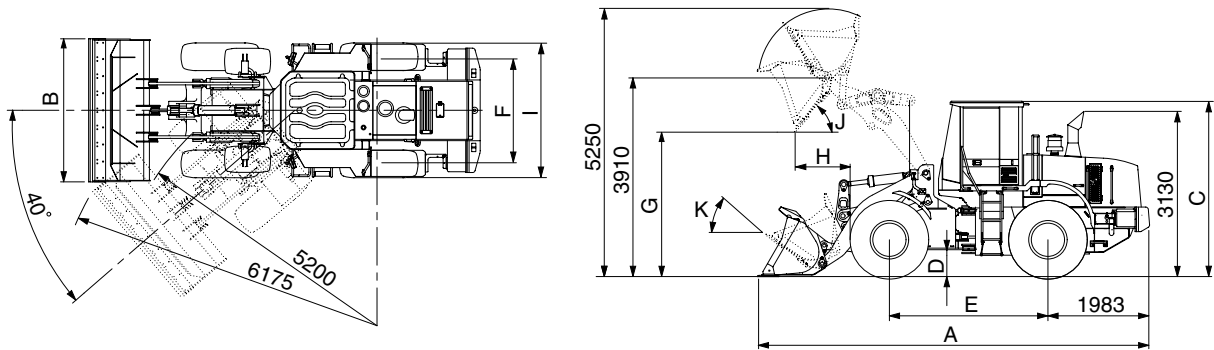

7577A2SE03

Description		Unit	Specification	
Operating weight		kg(lb)	14500(31970)	
Bucket capacity	Struck	m <sup>3</sup> (yd <sup>3</sup> )	2.3(3.0)	
	Heaped		2.7(3.5)	
Overall length	A	mm(ft-in)	7450(24' 5")	
Overall width	B		2740( 9' 0")	
Overall height	C		3300(10'10")	
Ground clearance	D		410( 1' 4")	
Wheelbase	E		3030( 9'11")	
Tread	F		2050( 6' 9")	
Dump clearance at 45°	G		2860( 9' 5")	
Dump reach(Full lift)	H		1040( 3' 4")	
Width over tires	I		2580( 8' 6")	
Dump angle	J		Degree (°)	47
Roll back angle(Carry position)	K			46
Cycle time	Lift(With load)	sec	5.9	
	Dump(With load)		1.2	
	Lower(Empty)		3.0	
Maximum travel speed		km/hr(mph)	36.0(22.4)	
Braking distance		m(ft-in)	12(39' 4")	
Minimum turning radius(Center of outside tire)			5.2(17' 1")	
Gradability		Degree (°)	30	
Travel speed	Forward	km/hr(mph)	First gear	7.0(4.4)
			Second gear	11.5(7.2)
			Third gear	22.9(14.3)
			Fourth gear	36.0(22.4)
	Reverse		First gear	7.3(4.5)
			Second gear	12.1(7.5)
Third gear		23.9(14.9)		

**WITH BOLT-ON CUTTING EDGE TYPE BUCKET(HL757XTD-7A)**

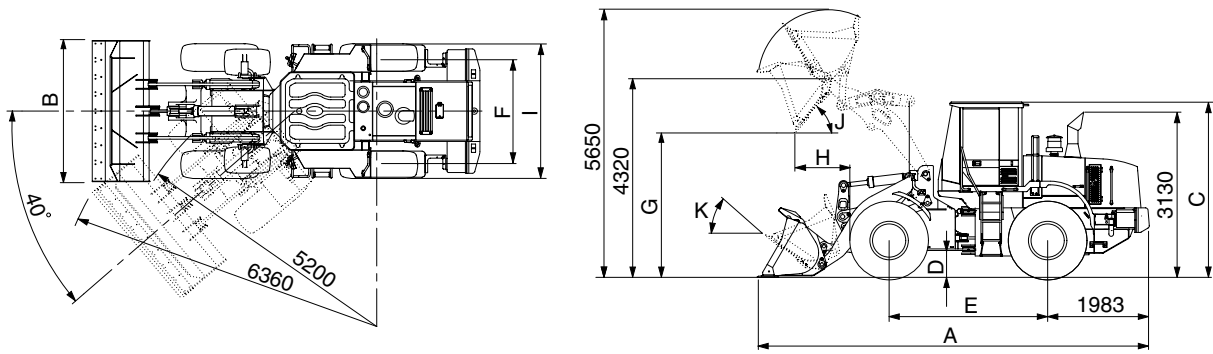

7577A2SE02

Description		Unit	Specification	
Operating weight		kg(lb)	15000(33070)	
Bucket capacity	Struck	m <sup>3</sup> (yd <sup>3</sup> )	2.3(3.0)	
	Heaped		2.7(3.5)	
Overall length	A	mm(ft-in)	7880(25'10")	
Overall width	B		2740( 9' 0")	
Overall height	C		3300(10'10")	
Ground clearance	D		410( 1' 4")	
Wheelbase	E		3030( 9'11")	
Tread	F		2050( 6' 9")	
Dump clearance at 45°	G		3270(10' 9")	
Dump reach(Full lift)	H		1060( 3' 6")	
Width over tires	I		2580( 8' 6")	
Dump angle	J		Degree (°)	47
Roll back angle(Carry position)	K			48
Cycle time	Lift(With load)	sec	5.9	
	Dump(With load)		1.2	
	Lower(Empty)		3.0	
Maximum travel speed		km/hr(mph)	36.0(22.4)	
Braking distance		m(ft-in)	12(39' 4")	
Minimum turning radius(Center of outside tire)			5.2(17' 1")	
Gradability		Degree (°)	30	
Travel speed	Forward	km/hr(mph)	First gear	
			Second gear	
			Third gear	
	Reverse		First gear	
			Second gear	
			Third gear	

**WITH BOLT-ON CUTTING EDGE TYPE BUCKET(HL757TM-7A)**

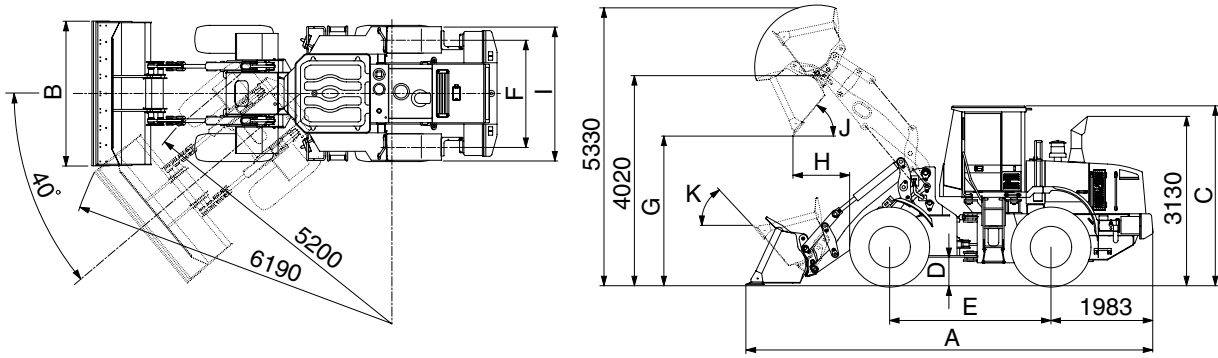

757TM7ASE03

Description		Unit	Specification	
Operating weight		kg(lb)	15000(33070)	
Bucket capacity	Struck	m <sup>3</sup> (yd <sup>3</sup> )	2.1(2.7)	
	Heaped		2.5(3.3)	
Overall length	A	mm(ft-in)	7670( 25' 2")	
Overall width	B		2740( 9' 0")	
Overall height	C		3300(10'10")	
Ground clearance	D		410( 1' 4")	
Wheelbase	E		3030( 9'11")	
Tread	F		2050( 6' 9")	
Dump clearance at 45°	G		2900( 9' 6")	
Dump reach(Full lift)	H		1280( 4' 2")	
Width over tires	I		2580( 8' 6")	
Dump angle	J		Degree (°)	50
Roll back angle(Carry position)	K			54
Cycle time	Lift(With load)	sec	5.9	
	Dump(With load)		1.7	
	Lower(Empty)		3.0	
Maximum travel speed		km/hr(mph)	36.0(22.4)	
Braking distance		m(ft-in)	12(39' 4")	
Minimum turning radius(Center of outside tire)			5.2(17' 1")	
Gradability		Degree (°)	30	
Travel speed	Forward	First gear	7(4.4)	
		Second gear	11.5(7.2)	
		Third gear	22.9(14.3)	
		Fourth gear	36.0(22.4)	
	Reverse	First gear	7.3(4.5)	
		Second gear	12.1(7.5)	
Third gear		23.9(14.9)		

## 2) WITH TOOTH TYPE BUCKET(HL757-7A)

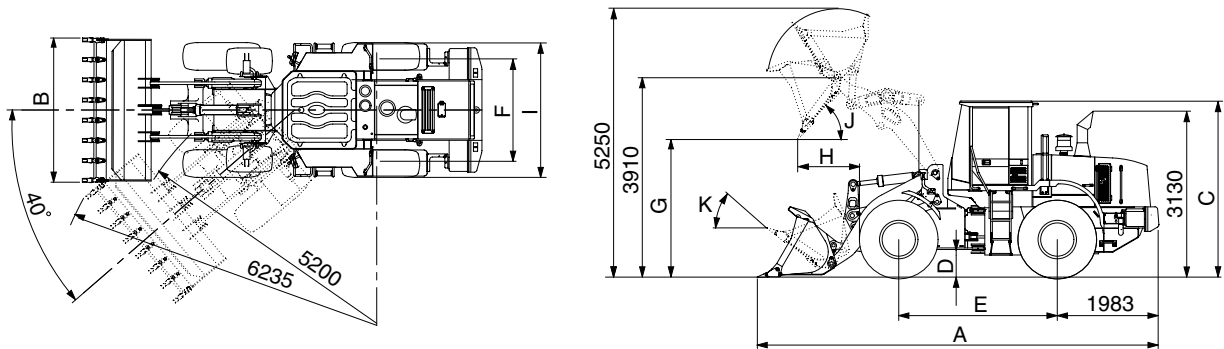

7577A2SE04

Description		Unit	Specification	
Operating weight		kg(lb)	14500(31970)	
Bucket capacity	Struck	m <sup>3</sup> (yd <sup>3</sup> )	2.3(3.0)	
	Heaped		2.6(3.4)	
Overall length	A	mm(ft-in)	7550(24' 9")	
Overall width	B		2790( 9' 2")	
Overall height	C		3300(10'10")	
Ground clearance	D		410( 1' 4")	
Wheelbase	E		3030( 9'11")	
Tread	F		2050( 6' 9")	
Dump clearance at 45°	G		2770( 9' 1")	
Dump reach(Full lift)	H		1140( 3' 9")	
Width over tires	I		2580( 8' 6")	
Dump angle	J		Degree (°)	47
Roll back angle(Carry position)	K			46
Cycle time	Lift(With load)		sec	5.9
	Dump(With load)			1.2
	Lower(Empty)	3.0		
Maximum travel speed		km/hr(mph)	36.0(22.4)	
Braking distance		m(ft-in)	12(39' 4")	
Minimum turning radius(Center of outside tire)			5.2(17' 1")	
Gradability		Degree (°)	30	
Travel speed	Forward	First gear	7.0(4.4)	
		Second gear	11.5(7.2)	
		Third gear	22.9(14.3)	
		Fourth gear	36.0(22.4)	
	Reverse	First gear	7.3(4.5)	
		Second gear	12.1(7.5)	
Third gear		23.9(14.9)		

**WITH TOOTH TYPE BUCKET(HL757XTD-7A)**

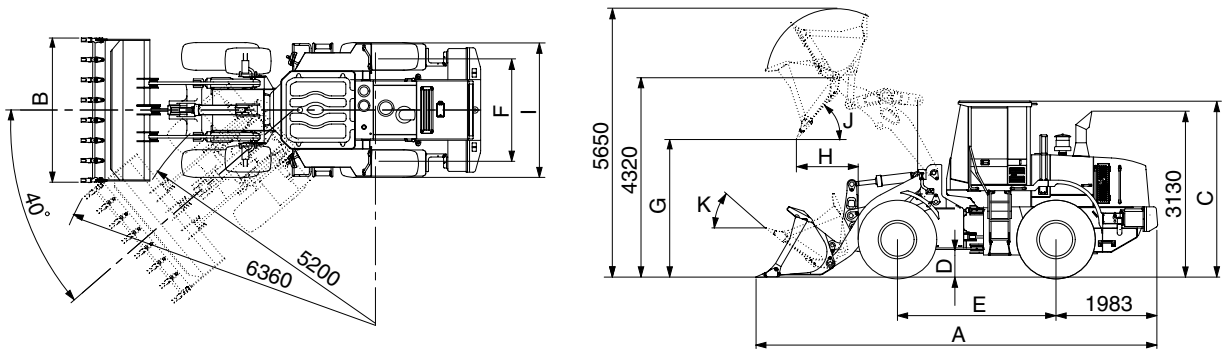

7577A2SE05

Description		Unit	Specification	
Operating weight		kg(lb)	15000(33070)	
Bucket capacity	Struck	m <sup>3</sup> (yd <sup>3</sup> )	2.3(3.0)	
	Heaped		2.6(3.4)	
Overall length	A	mm(ft-in)	7880(25'10")	
Overall width	B		2790( 9' 2")	
Overall height	C		3300(10'10")	
Ground clearance	D		410( 1' 4")	
Wheelbase	E		3030( 9'11")	
Tread	F		2050( 6' 9")	
Dump clearance at 45°	G		2930( 9' 7")	
Dump reach(Full lift)	H		1060( 3' 6")	
Width over tires	I		2580( 8' 6")	
Dump angle	J		Degree (°)	47
Roll back angle(Carry position)	K		Degree (°)	48
Cycle time	Lift(With load)		sec	5.9
	Dump(With load)			1.2
	Lower(Empty)	3.0		
Maximum travel speed		km/hr(mph)	36.0(22.4)	
Braking distance		m(ft-in)	12(39' 4")	
Minimum turning radius(Center of outside tire)			5.2(17' 1")	
Gradability		Degree (°)	30	
Travel speed	Forward	First gear	7.0(4.4)	
		Second gear	11.5(7.2)	
		Third gear	22.9(14.3)	
		Fourth gear	36.0(22.4)	
	Reverse	First gear	7.3(4.5)	
		Second gear	12.1(7.5)	
Third gear		23.9(14.9)		

### 3. WEIGHT

Item		kg	lb
Front frame assembly	HL757-7A/XTD-7A	1168	2580
	HL757TM-7A	1235	2720
Rear frame assembly		1573	3470
Front fender(LH & RH)		25	55
Counterweight	HL757-7A	550	1210
	HL757XTD-7A/TM-7A	820	1810
Cab assembly		1020	2250
Engine assembly		485	1070
Transmission assembly		470	1040
Drive shaft(Front)		18	40
Drive shaft(Center)		17	37
Drive shaft(Rear)		11	24
Front axle(Include differential)		640	1410
Rear axle(Include differential)		576	1270
Tire(20.5-25, 16PR, L3)		203	448
Hydraulic tank assembly		205	452
Fuel tank assembly		353	778
Main pump assembly		37	82
Fan & brake pump assembly		7	15
Main control valve		51	112
Steering valve(EHPS)		10	22
Boom assembly	HL757-7A	980	2160
	HL757XTD-7A	1145	2524
	HL757TM-7A	910	2010
Bell crank assembly		264	580
Quick coupler(HL757TM-7A)		245	540
Bucket link		45	100
2.5m <sup>3</sup> bucket, with bolt on cutting edge		1065	2350
2.7m <sup>3</sup> bucket, with bolt on cutting edge		1135	2500
2.6m <sup>3</sup> bucket, with tooth		1060	2340
Boom cylinder assembly	HL757-7A/XTD-7A	110	243
	HL757TM-7A	120	265
Bucket cylinder assembly	HL757-7A/XTD-7A	122	269
	HL757TM-7A	100	220
Steering cylinder assembly		28	62
Quick coupler cylinder assembly(HL757TM-7A)		6	13
Seat		40	88
Battery		55	121



#### 4. SPECIFICATION FOR MAJOR COMPONENTS

##### 1) ENGINE

Item	Specification
Model	Cummins QSB6.7
Type	4-cycle turbocharged and charge air-cooled diesel engine
Control type	Electronic control
Cooling method	Water cooling
Number of cylinders and arrangement	6 cylinders, in-line
Firing order	1-5-3-6-2-4
Combustion chamber type	Direct injection type
Cylinder bore × stroke	104 × 132mm(4.1" × 5.2")
Piston displacement	6730cc(410cu in)
Compression ratio	17.2 : 1
Rated gross horse power	173hp at 2100rpm
Maximum gross torque at 1500rpm	83kgf · m(600lbf · ft)
Engine oil quantity	16 l (4.2 U.S. gal)
Wet weight	485kg(1069lb)
High idling speed	2230 ± 50rpm
Low idling speed	800 ± 50rpm
Rated fuel consumption	252g/kW · hr
Starting motor	Nippondenso 228000-7902 (24V-3.7kW)
Alternator	Delco Remy 24SI(24V-70Amp)
Battery	2 × 12V × 160Ah

## 2) MAIN PUMP

Item	Specification
Type	Fixed displacement double helical gear pump
Capacity	56+56cc/rev
Maximum operating pressure	210kgf/cm <sup>2</sup> (2990psi)
Rated oil quantity	230 l /min(60.8U.S.gpm / 50.6U.K.gpm)
Rated speed	2100rpm

## 3) FAN + BRAKE PUMP

Item	Specification	
	Fan	Brake
Type	Fixed displacement tandem gear pump	
Capacity	19cc/rev	11.9cc/rev
Maximum operating pressure	115kgf/cm <sup>2</sup> (1640psi)	180kgf/cm <sup>2</sup> (2560psi)
Rated oil quantity	39 l /min(10.3U.S.gpm)	24 l /min(6.3 U.S.gpm)
Rated speed	2100rpm	

## 4) MAIN CONTROL VALVE

Item	Specification
Type	2 spool
Operating method	Hydraulic pilot assist
Main relief valve pressure	210kgf/cm <sup>2</sup> (2990psi)
Overload relief valve pressure	240kgf/cm <sup>2</sup> (3410psi)

## 5) REMOTE CONTROL VALVE

Item	Specification	
Type	Pressure reducing type	
Operating	Minimum	5.8kgf/cm <sup>2</sup> (82.5psi)
	Maximum	19kgf/cm <sup>2</sup> (270psi)
Single operation stroke	Lever	70mm(2.8in)

## 6) CYLINDER

Item		Specification
Boom cylinder	Bore dia × Rod dia × Stroke	∅ 140 × ∅ 75 × 750mm
Bucket cylinder	Bore dia × Rod dia × Stroke	∅ 160 × ∅ 80 × 475mm
*Bucket cylinder	Bore dia × Rod dia × Stroke	∅ 120 × ∅ 65 × 775mm
Steering cylinder	Bore dia × Rod dia × Stroke	∅ 70 × ∅ 45 × 436mm
*Quick coupler cylinder	Bore dia × Rod dia × Stroke	∅ 50 × ∅ 25 × 105mm

\*HL757TM-7A

## 7) DYNAMIC POWER TRANSMISSION DEVICES

Item		Specification	
Transmission	Model	4WG190	
	Type	Converter	Single-stage, single-phase
		Transmission	Full-automatic power shift
	Gear shift	Forward fourth gear, reverse third gear	
	Adjustment	Electrical single lever type, kick-down system	
Axle	Drive devices	4-wheel drive	
	Front	Front fixed location	
	Rear	Oscillation $\pm 13^\circ$ of center pin-loaded	
Wheels	Tires	20.5-25, 16PR(L3)	
Brakes	Travel	Four-wheel, wet-disc type, full hydraulic	
	Parking	Spring applied, hydraulic released brake on transmission	
Steering	Type	Full hydraulic, articulated	
	Steering angle	40° to both right and left angle, respectively	

## 5. TIGHTENING TORQUE OF MAJOR COMPONENT

No.		Items	Size	kgf · m	lbf · ft
1	Engine	Engine mounting bolt, nut(Rubber, 2EA)	M20×2.5	57.9 ± 8.7	419± 62.9
2		Engine mounting bolt(Bracket, 8EA)	M12×1.75	10.7 ± 1.6	77.4± 11.6
3		Engine mounting bolt(Flywheel housing,12EA)	M10×1.5	4.6 ± 0.9	33.3± 6.5
4		Radiator mounting bolt	M16×2.0	29.7± 4.5	215± 32.5
5		Fuel tank mounting bolt, nut	M16×2.0	29.7 ± 4.5	215± 32.5
6	Hydraulic system	Main pump housing mounting bolt	M12×1.75	12.8 ± 3.0	92.6± 21.7
7		Brake pump housing mounting bolt	M10×1.5	6.9 ± 1.4	49.9± 10.1
8		Main control valve mounting bolt	M12×1.75	12.8 ± 3.0	92.6± 21.7
9		Steering unit mounting bolt	M10×1.5	6.9 ± 1.4	49.9± 10.1
10		Steering valve(EHPS) mounting bolt	M8×1.25	2.5 ± 0.5	18.1± 3.6
11		Brake valve mounting bolt	M8×1.25	2.5 ± 0.5	18.1± 3.6
12		Cut-off valve mounting bolt	M12×1.75	12.8 ± 3.0	92.6± 21.7
13		Remote control lever mounting bolt	M6×1.0	1.1±0.2	8.0± 1.4
14		Pilot supply unit mounting bolt	M8×1.25	2.5 ± 0.5	18.1± 3.6
15		Safety valve	M8×1.25	2.5 ± 0.5	8.1± 3.6
16	Hydraulic oil tank mounting bolt	M16×2.0	29.7 ± 4.5	215 ± 32.5	
17	Power train system	Transmission mounting bolt, nut(Rubber, 2EA)	M24×3.0	100 ± 15	723 ± 108
18		Transmission mounting bolt(Bracket)	M20×2.5	46.3 ± 7.0	335± 50.6
19		Front axle mounting bolt, nut	M24×2.0	100 ± 15	723± 108
20		Rear axle support mounting bolt, nut	M27×2.0	135 ± 15	976± 108
21		Tire mounting nut	M22×1.5	79 ± 2.5	571± 18.1
22		Drive shaft joint mounting bolt, nut	3/8-24UNF	6.0 ± 0.8	43.4± 5.8
23	Others	Counterweight mounting bolt	M30×3.5	199 ± 29.9	1439± 216
24		Operator's seat mounting bolt	M8×1.25	3.4 ± 0.8	24.6± 5
25		ROPS Cab mounting bolt(4EA)	M27×2.0	125 ± 15	904 ± 108

## 6. TORQUE CHART

Use following table for unspecified torque.

### 1) BOLT AND NUT

#### (1) Coarse thread

Bolt size	8T		10T	
	kgf · m	lbf · ft	kgf · m	lbf · ft
M 6 × 1.0	0.85 ~ 1.25	6.15 ~ 9.04	1.14 ~ 1.74	8.2 ~ 12.6
M 8 × 1.25	2.0 ~ 3.0	14.5 ~ 21.7	2.73 ~ 4.12	19.7 ~ 29.8
M10 × 1.5	4.0 ~ 6.0	28.9 ~ 43.4	5.5 ~ 8.3	39.8 ~ 60
M12 × 1.75	7.4 ~ 11.2	53.5 ~ 79.5	9.8 ~ 15.8	71 ~ 114
M14 × 2.0	12.2 ~ 16.6	88.2 ~ 120	16.7 ~ 22.5	121 ~ 167
M16 × 2.0	18.6 ~ 25.2	135 ~ 182	25.2 ~ 34.2	182 ~ 247
M18 × 2.5	25.8 ~ 35.0	187 ~ 253	35.1 ~ 47.5	254 ~ 343
M20 × 2.5	36.2 ~ 49.0	262 ~ 354	49.2 ~ 66.6	356 ~ 482
M22 × 2.5	48.3 ~ 63.3	350 ~ 457	65.8 ~ 98.0	476 ~ 709
M24 × 3.0	62.5 ~ 84.5	452 ~ 611	85.0 ~ 115	615 ~ 832
M30 × 3.5	124 ~ 168	898 ~ 1214	169 ~ 229	1223 ~ 1655
M36 × 4.0	174 ~ 236	1261 ~ 1703	250 ~ 310	1808 ~ 2242

#### (2) Fine thread

Bolt size	8T		10T	
	kgf · m	lbf · ft	kgf · m	lbf · ft
M 8 × 1.0	2.17 ~ 3.37	15.7 ~ 24.3	3.04 ~ 4.44	22.0 ~ 32.0
M10 × 1.25	4.46 ~ 6.66	32.3 ~ 48.2	5.93 ~ 8.93	42.9 ~ 64.6
M12 × 1.25	7.78 ~ 11.58	76.3 ~ 83.7	10.6 ~ 16.0	76.6 ~ 115
M14 × 1.5	13.3 ~ 18.1	96.2 ~ 130	17.9 ~ 24.1	130 ~ 174
M16 × 1.5	19.9 ~ 26.9	144 ~ 194	26.6 ~ 36.0	193 ~ 260
M18 × 1.5	28.6 ~ 43.6	207 ~ 315	38.4 ~ 52.0	278 ~ 376
M20 × 1.5	40.0 ~ 54.0	289 ~ 390	53.4 ~ 72.2	386 ~ 522
M22 × 1.5	52.7 ~ 71.3	381 ~ 515	70.7 ~ 95.7	512 ~ 692
M24 × 2.0	67.9 ~ 91.9	491 ~ 664	90.9 ~ 123	658 ~ 890
M30 × 2.0	137 ~ 185	990 ~ 1338	182 ~ 248	1314 ~ 1795
M36 × 3.0	192 ~ 260	1389 ~ 1879	262 ~ 354	1893 ~ 2561

## 2) PIPE AND HOSE(FLARE TYPE)

Thread size	Width across flat(mm)	kgf · m	lbf · ft
1/4"	19	4	28.9
3/8"	22	5	36.2
1/2"	27	9.5	68.7
3/4"	36	18	130
1"	41	21	152
1-1/4"	50	35	253

## 3) PIPE AND HOSE(ORFS TYPE)

Thread size	Width across flat(mm)	kgf · m	lbf · ft
9/16-18	19	4	28.9
11/16-16	22	5	36.2
13/16-16	27	9.5	68.7
1-3/16-12	36	18	130
1-7/16-12	41	21	152
1-11/16-12	50	35	253

## 4) FITTING

Thread size	Width across flat(mm)	kgf · m	lbf · ft
1/4"	19	4	28.9
3/8"	22	5	36.2
1/2"	27	9.5	68.7
3/4"	36	18	130
1"	41	21	152
1-1/4"	50	35	253

## 7. RECOMMENDED LUBRICANTS

Use only oils listed below or equivalent.

Do not mix different brand oil.

Service point	Kind of fluid	Capacity l (U.S. gal)	Ambient temperature °C (°F)						
			-20 (-4)	-10 (14)	0 (32)	10 (50)	20 (68)	30 (86)	40 (104)
Engine oil pan	Engine oil	16(4.2)	SAE 30						
			SAE 10W						
			SAE 10W-30						
			SAE 15W-40						
Transmission	Oil	43(11.4)	SAE 10W-30						
			SAE 15W-40						
Axle	UTTO	Front : 29(7.7) Rear : 24(6.3)	*Refer to below list						
Hydraulic tank	Hydraulic oil	Tank: 125(33)  System: 175(46)	ISO VG 32						
			ISO VG 46						
			ISO VG 68						
Fuel tank	Diesel fuel	295(78)	ASTM D975 NO. 1						
			ASTM D975 NO. 2						
Fitting (Grease nipple)	Grease	As required	NLGI NO. 1						
			NLGI NO. 2						
Radiator	Mixture of antifreeze and water 50 : 50	35(9.2)	Ethylene glycol base permanent type						

• SAE : Society of Automotive Engineers

• API : American Petroleum Institute

• ISO : International Organization for Standardization

• NLGI : National Lubricating Grease Institute

• ASTM : American Society of Testing and Material

• UTTO : Universal Tractor Transmission Oil

\* Recommended oil list

- BP TERRAC SUPER TRANSMISSION 10W-30

- CASTROL AGRI TRANS PLUS 10W-30

- MOBILFLUID 426

- SHELL DONAX TD 10W-30

- TOTAL DYNATRANS MPV