

GROUP 2 ELECTRICAL CIRCUIT

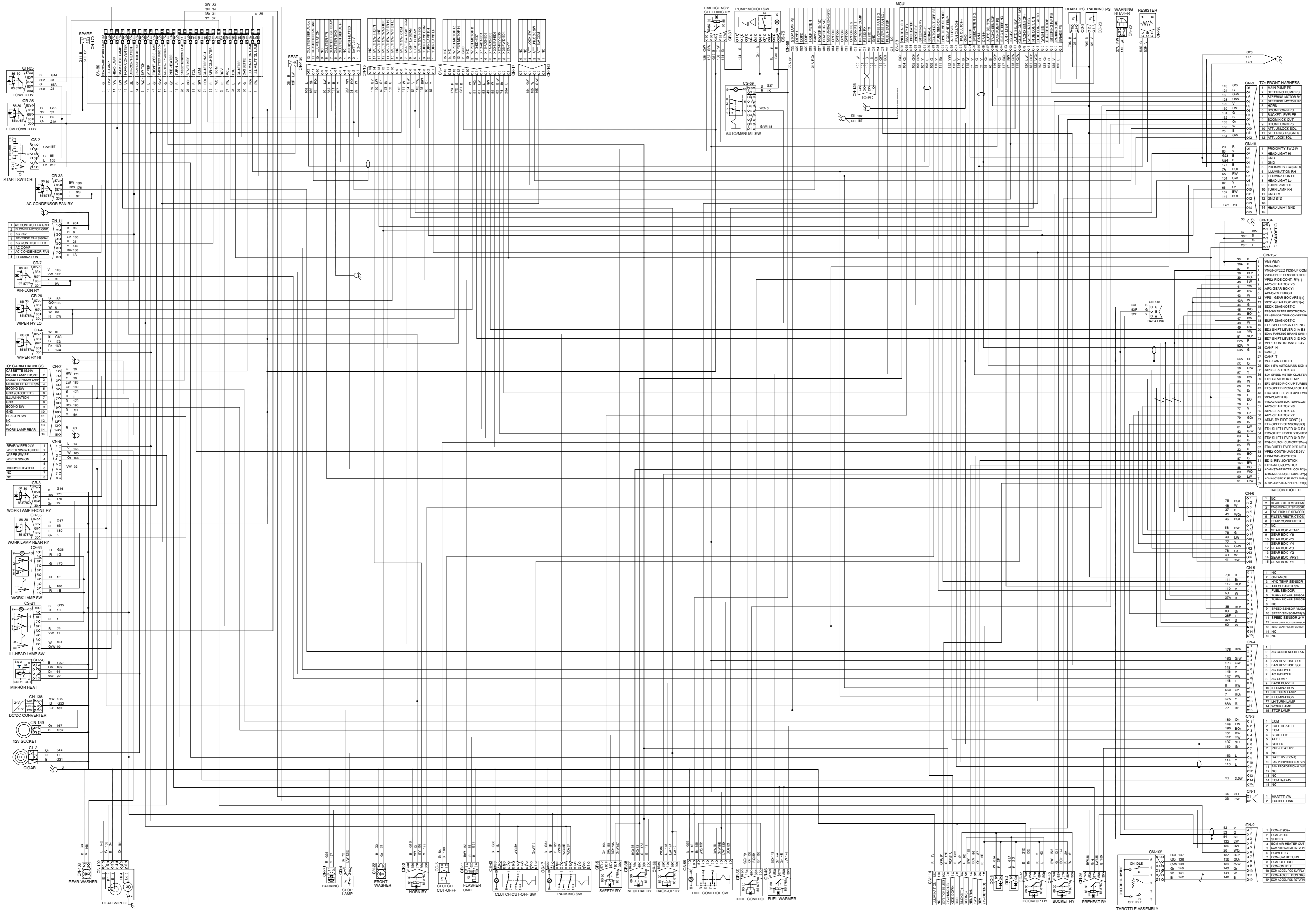

ENGINE HARNESS

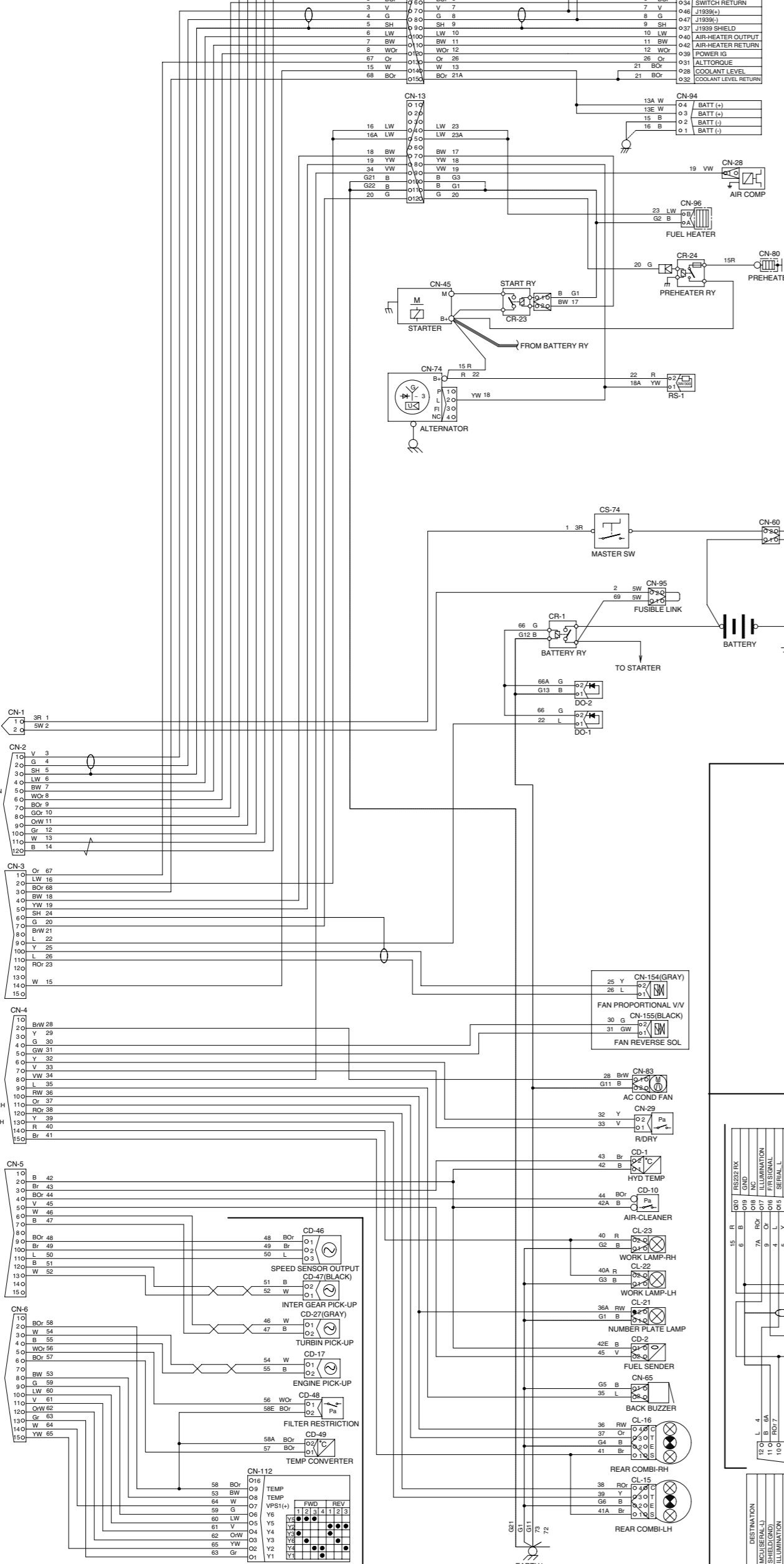

TRANSMISSION



JOY STICK

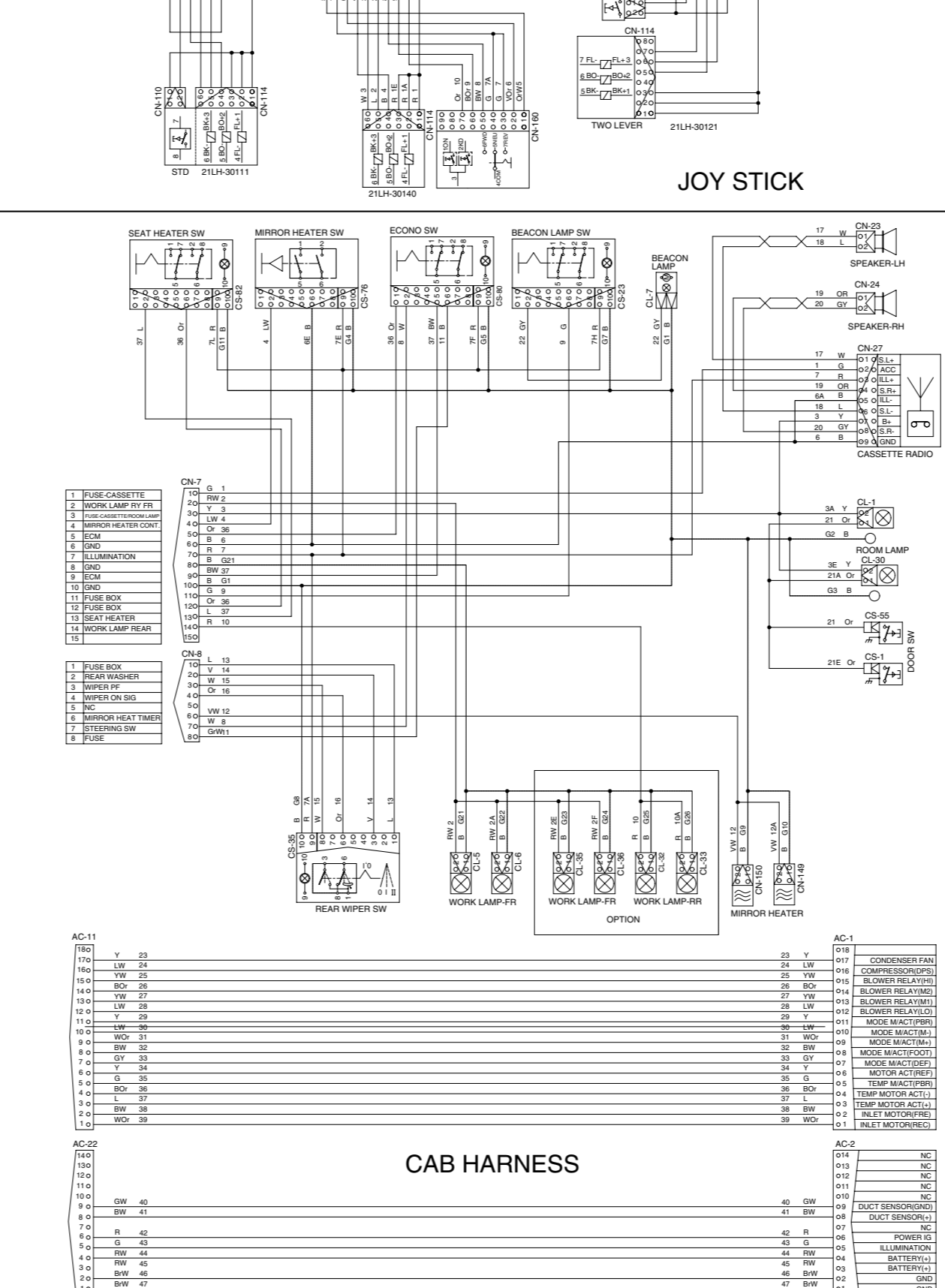

CAB HARNESS

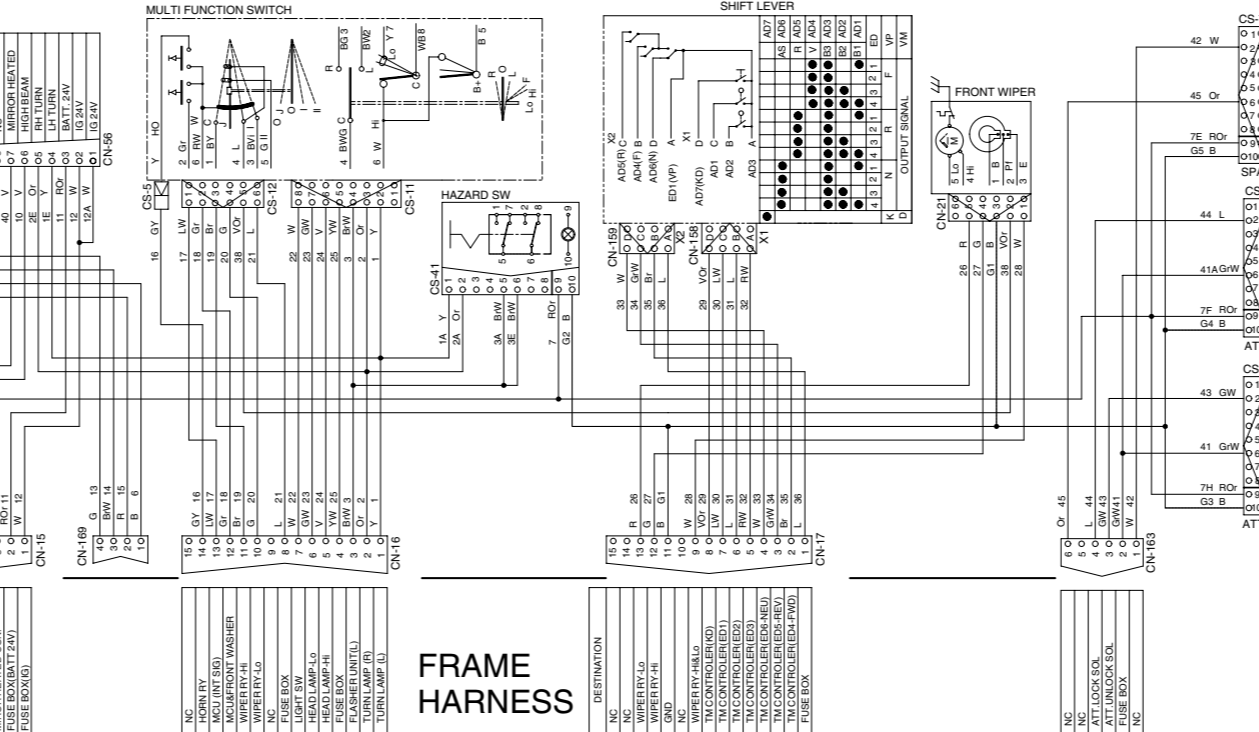

FRAME HARNESS



FRONT HARNESS

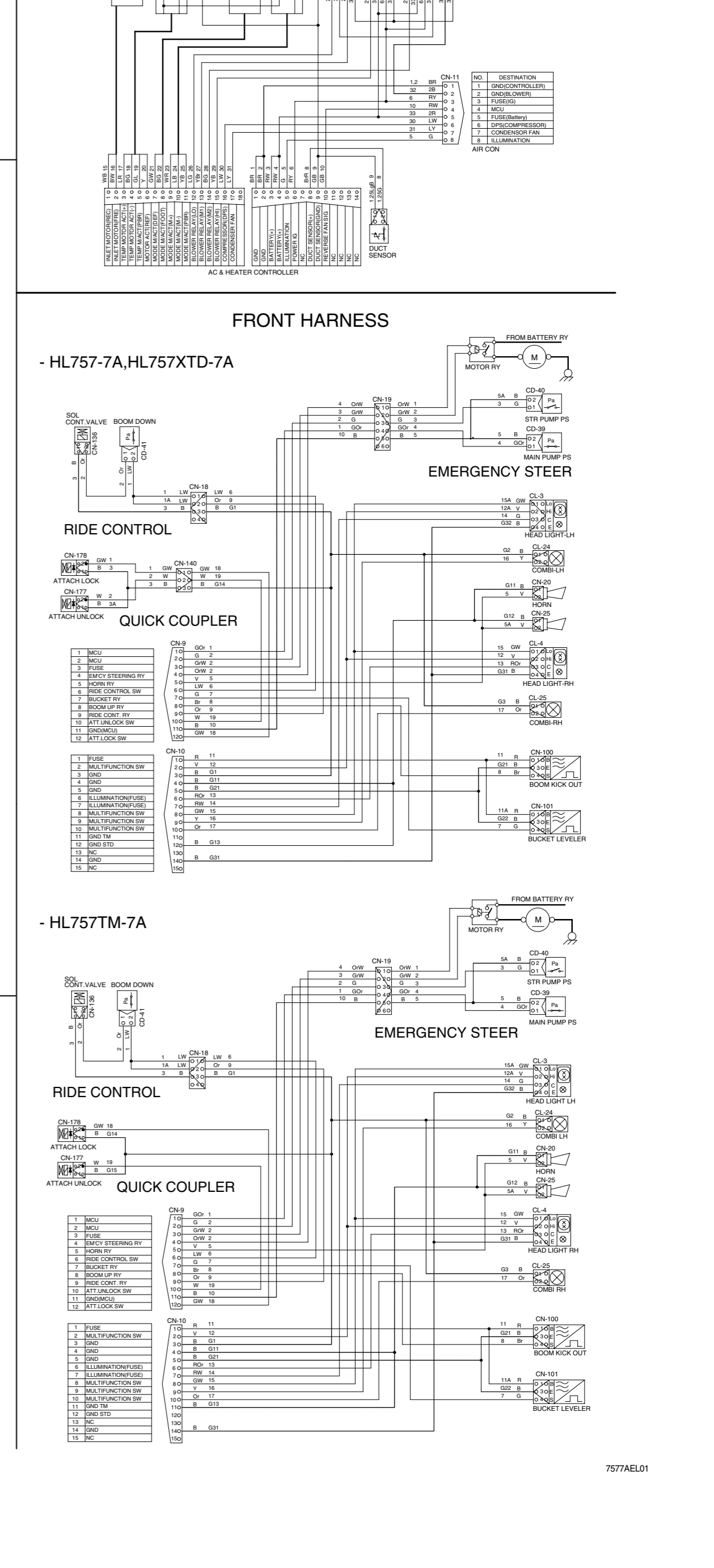



1. ILLUMINATION CIRCUIT

1) OPERATING FLOW

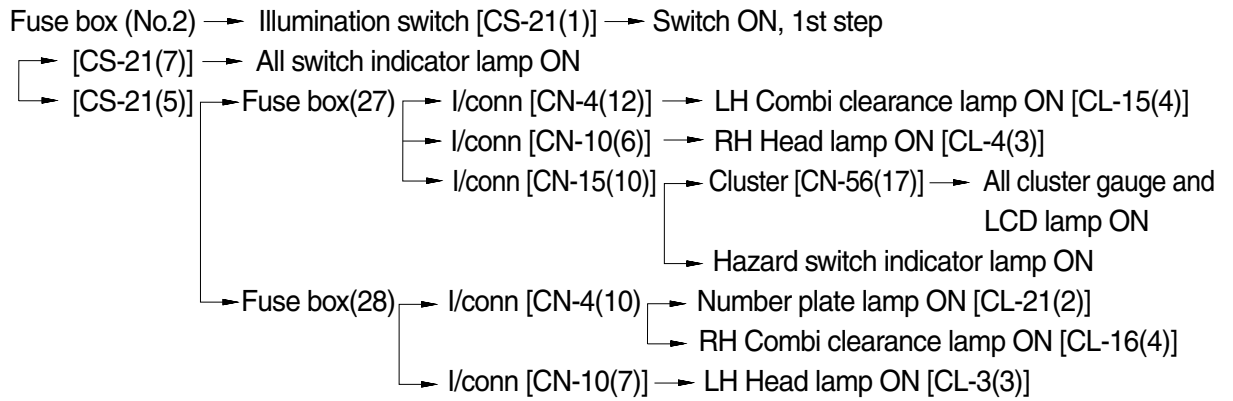

2) CHECK POINT

Engine	Key switch	Check point	Voltage
OFF	ON	① - GND (Switch input) ② - GND (Switch output) ③ - GND (To light) ④ - GND (To cluster)	20~25V

※ GND : Ground

ILLUMINATION CIRCUIT

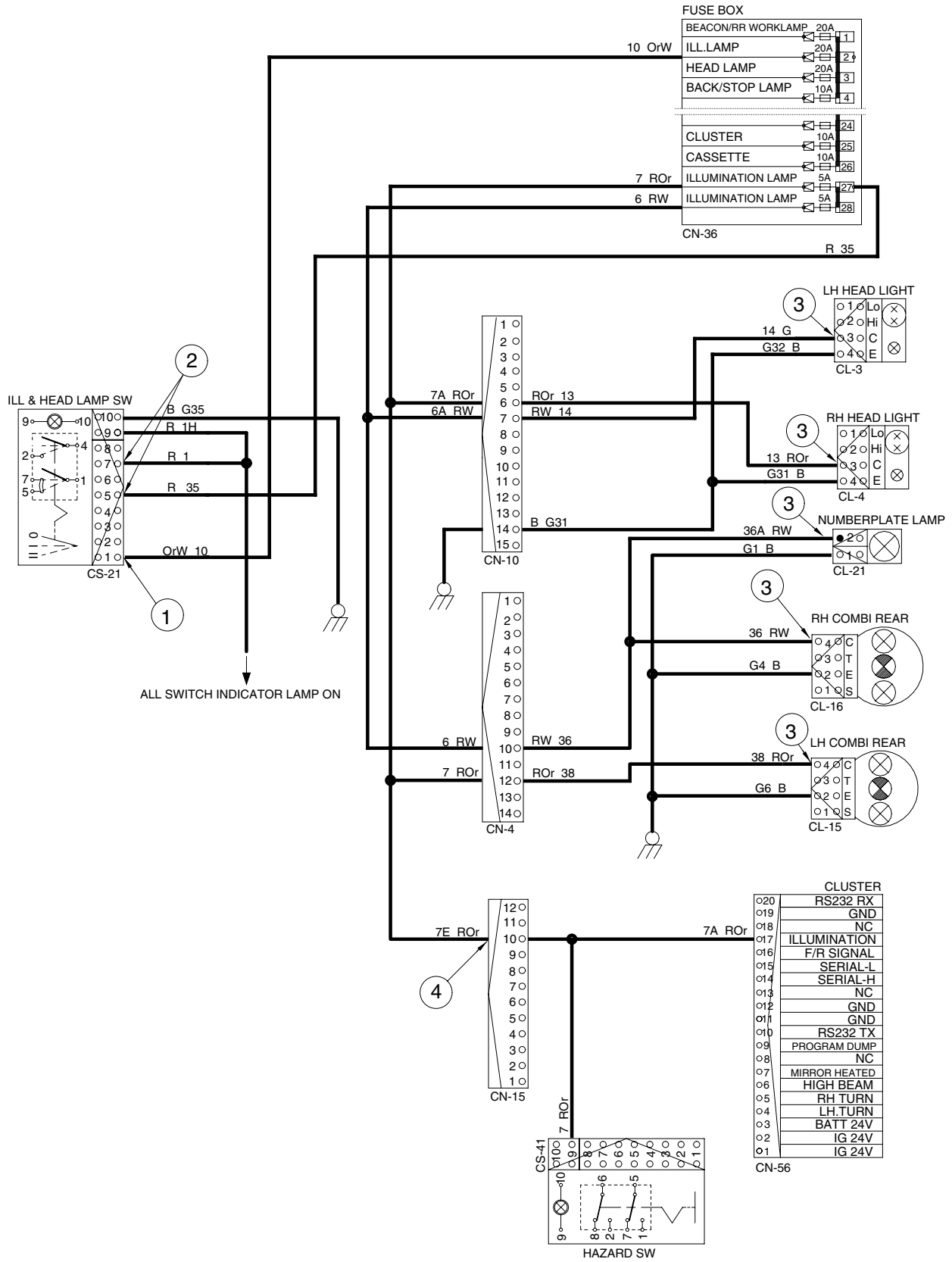

2. HEAD LIGHT CIRCUIT

1) OPERATING FLOW

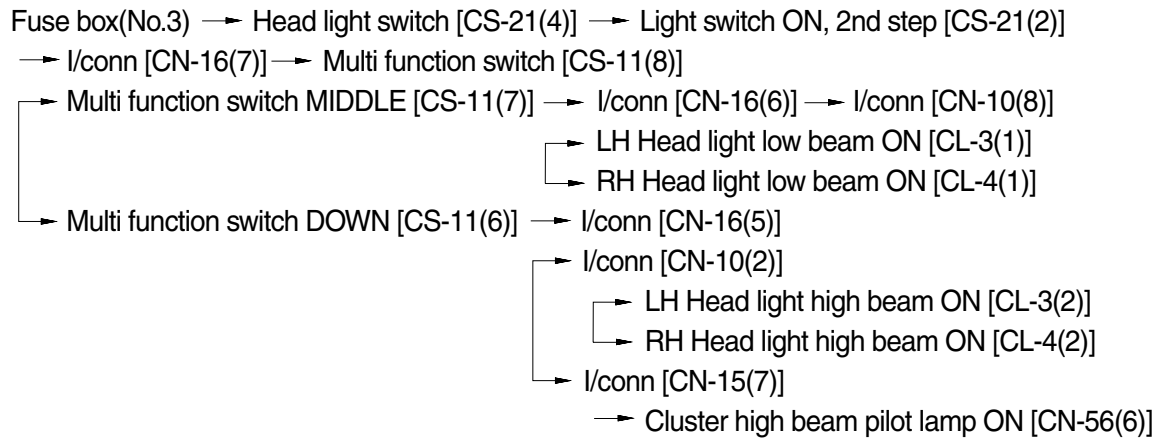

2) CHECK POINT

Engine	Key switch	Check point	Voltage
OFF	ON	① - GND (Switch input) ② - GND (Switch output) ③ - GND (Multi function input) ④ - GND (Multi function output) ⑤ - GND (Multi function output) ⑥ - GND (Low beam) ⑦ - GND (High beam) ⑧ - GND (Passing B+)	20~25V

※ GND : Ground

HEAD LIGHT CIRCUIT

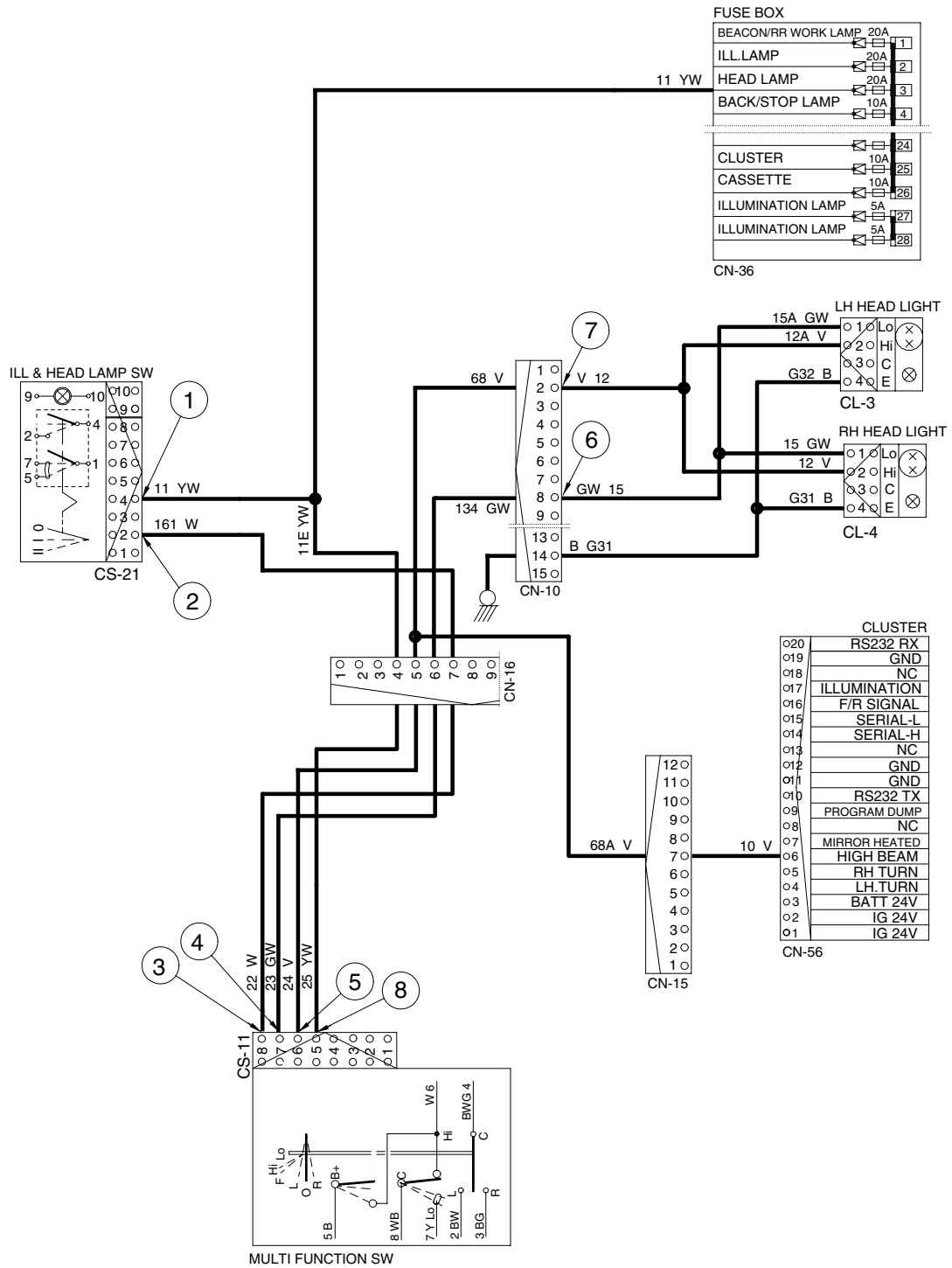

7707AEL04

3. WORK LIGHT SWITCH

1) OPERATING FLOW

※ Illumination switch : ON position(1st step)

(1) Work lamp switch ON (1st step)

ILL & head lamp switch [CS-21(7)] → Work lamp switch indicate lamp ON
 → Work lamp switch [CS-36(1)→(7)] →
 Front work lamp relay[CR-3(30)→(87)] → I/conn [CN-7(2)]
 → RH Front work lamp ON [CL-5(2)]
 → LH Front work lamp ON [CL-6(2)]

(2) Work lamp switch (2nd step)

Work lamp switch [CS-36(4)→(2)] → Rear work lamp relay [CR-55(30)→(87)] →
 I/conn [CN-4(14)] → LH Rear work lamp ON [CL-22(2)]
 → RH Rear work lamp ON [CL-23(2)]

2) CHECK POINT

Engine	Key switch	Check point	Voltage
OFF	ON	① - GND (Work lamp power input) ② - GND (Work lamp power output) ③ - GND (Front work lamp) ④ - GND (Rear work lamp)	20~25V

※ GND : Ground

WORK LIGHT SWITCH

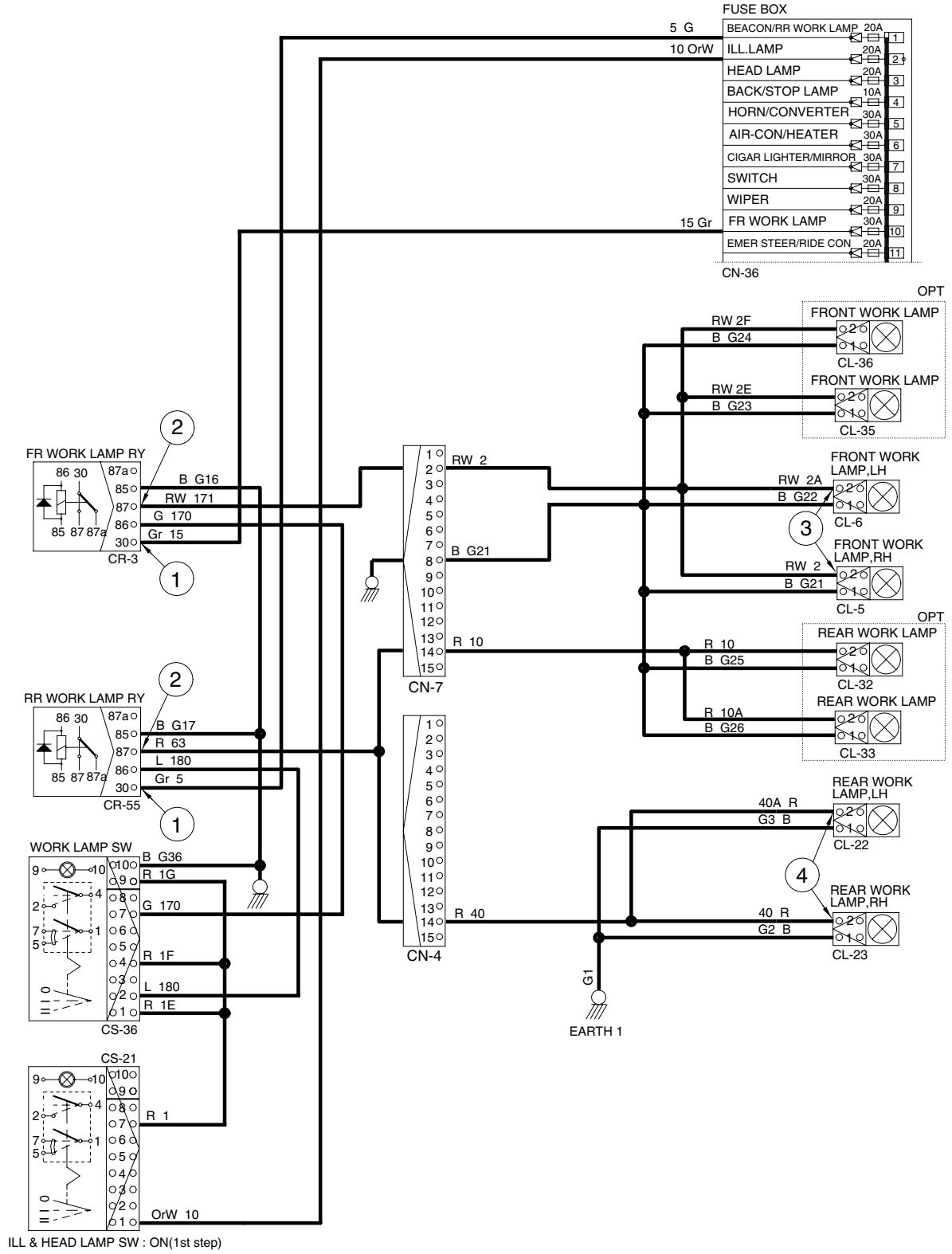

4. STARTING CIRCUIT

1) OPERATING FLOW

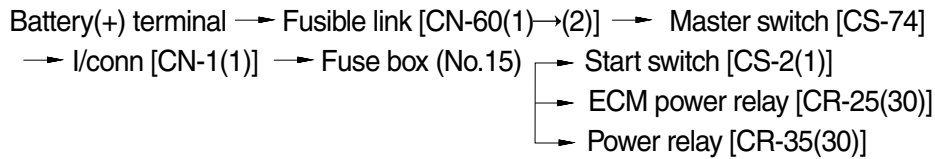

※ The gear selector lever is neutral position. It is necessary condition before the starting.

The gear selector has an output signal which is activated whenever the shift lever is in the neutral position. This signal can be used to control a relay and prevent engine from starting whenever the shift lever is not in the neutral position.

(1) When start key switch is in ON position

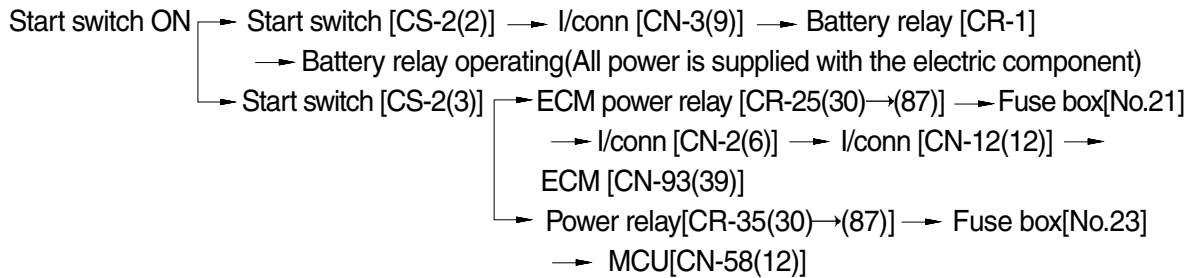

(2) When start key switch is in START position

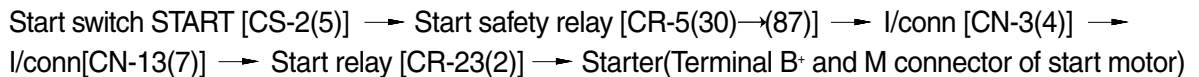

2) CHECK POINT

Engine	Key switch	Check point	Voltage
Running	ON	① - GND (Battery B ⁺) ② - GND (Fusible link) ③ - GND (Start key B terminal) ④ - GND (Start key BR terminal) ⑤ - GND (I/conn CN-3(9)) ⑥ - GND (Start key ST terminal) ⑦ - GND (Start safety relay output) ⑧ - GND (Start key ACC terminal)	20~25V

※ GND : Ground

※ ECM : Electronic control module

※ MCU : Machine control unit

STARTING CIRCUIT

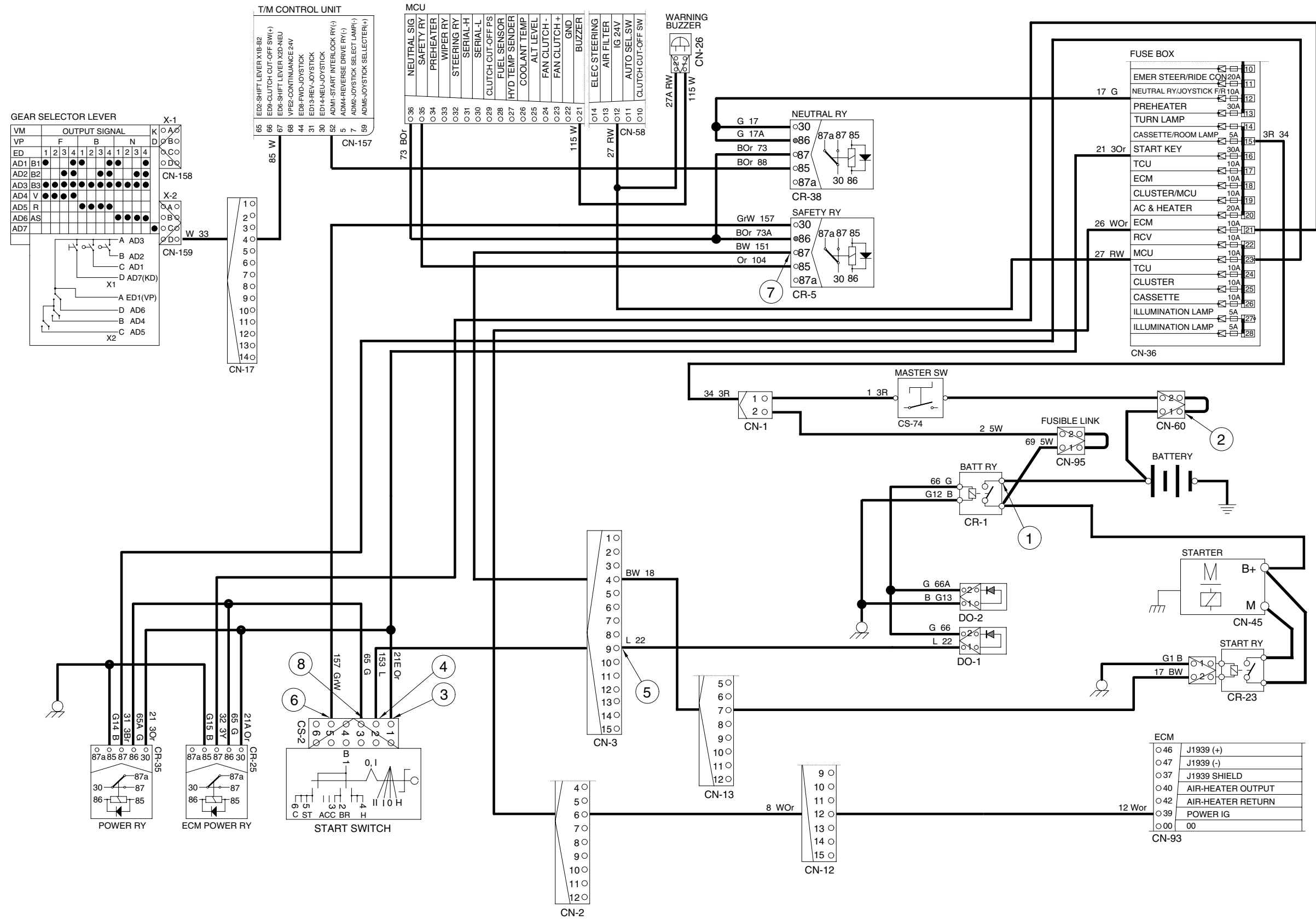

5. CHARGING CIRCUIT

When the starter is activated and the engine is started, the operator releases the key switch to the ON position.

Charging current generated by operating alternator flows into the battery through the battery relay (CR-1).

The current also flows from alternator to each electrical component and controller through the fuse box.

1) OPERATING FLOW

(1) Warning flow

Alternator [CN-74(2)] → I/conn [CN-13(8)] → I/conn [CN-3(5)] → MCU [CN-58(25)]
 → Cluster charge warning lamp ON

(2) Charging flow

Alternator → Starter [CN-45(B⁺)] → Battery relay [CR-1]
 → Battery(+) terminal → Charging
 → Fusible link [CN-95(1)→(2)] → I/conn [CN-1(2)] → Fuse box

2) CHECK POINT

Engine	Key switch	Check point	Voltage
Running	ON	① - GND (Battery) ② - GND (Battery relay) ③ - GND (Alternator B ⁺) ④ - GND (Alternator 2) ⑤ - GND (MCU) ⑥ - GND (Fuse box)	20~28V

※ GND : Ground

※ MCU : Machine control unit

CHARGING CIRCUIT

FUSE BOX

BEACON/RR WORK LAMP	20A	1
ILL. LAMP	20A	2
HEAD LAMP	20A	3
BACK/STOP LAMP	10A	4
HORN/CONVERTER	30A	5
AIR-CON/HEATER	30A	6
CIGAR/MIRROR	30A	7
SWITCH	30A	8
WIPER	20A	9
FR WORK LAMP	30A	10
EMER STEER/RIDE CON	20A	11
NEUTRAL RY/JOYSTICK F	10A	12
PREHEATER	30A	13
TURN LAMP	20A	14
CASSETTE/ROOM LAMP	5A	15
START KEY	30A	16
TCU	10A	17

CN-36

MCU

NEUTRAL SIG	01
SAFETY RY	02
PREHEATER	03
WIPER RY	04
STEERING RY	05
SERIAL-H	06
SERIAL-L	07
CLUTCH CUT-OFF PS	08
FUEL SENSOR	09
HYD TEMP SENDER	10
COOLANT TEMP	11
ALT LEVEL	12
FAN CLUTCH -	13
FAN CLUTCH +	14
GND	15
BUZZER	16
SPEEDMETER SIG.	17
CAN-L	18
CAN-H	19
AUTO SEL.TCU	20
TAHCO SENSOR -	21
MAIN PUMP PS	22
ELEC STEERING	23
AIR FILTER	24
IG 24V	25
AUTO SEL.SW	26
CLUTCH CUT-OFF SW	27
TACHO SENSOR+	28
WIPER INT SIG	29
RIDE CONT. ON	30
RIDE CONT. AUTO	31
WASH SIG	32
BUZZER STOP	33
STEERING P/P PS	34
PARKING SIG	35
BRAKE PS	36

CN-58

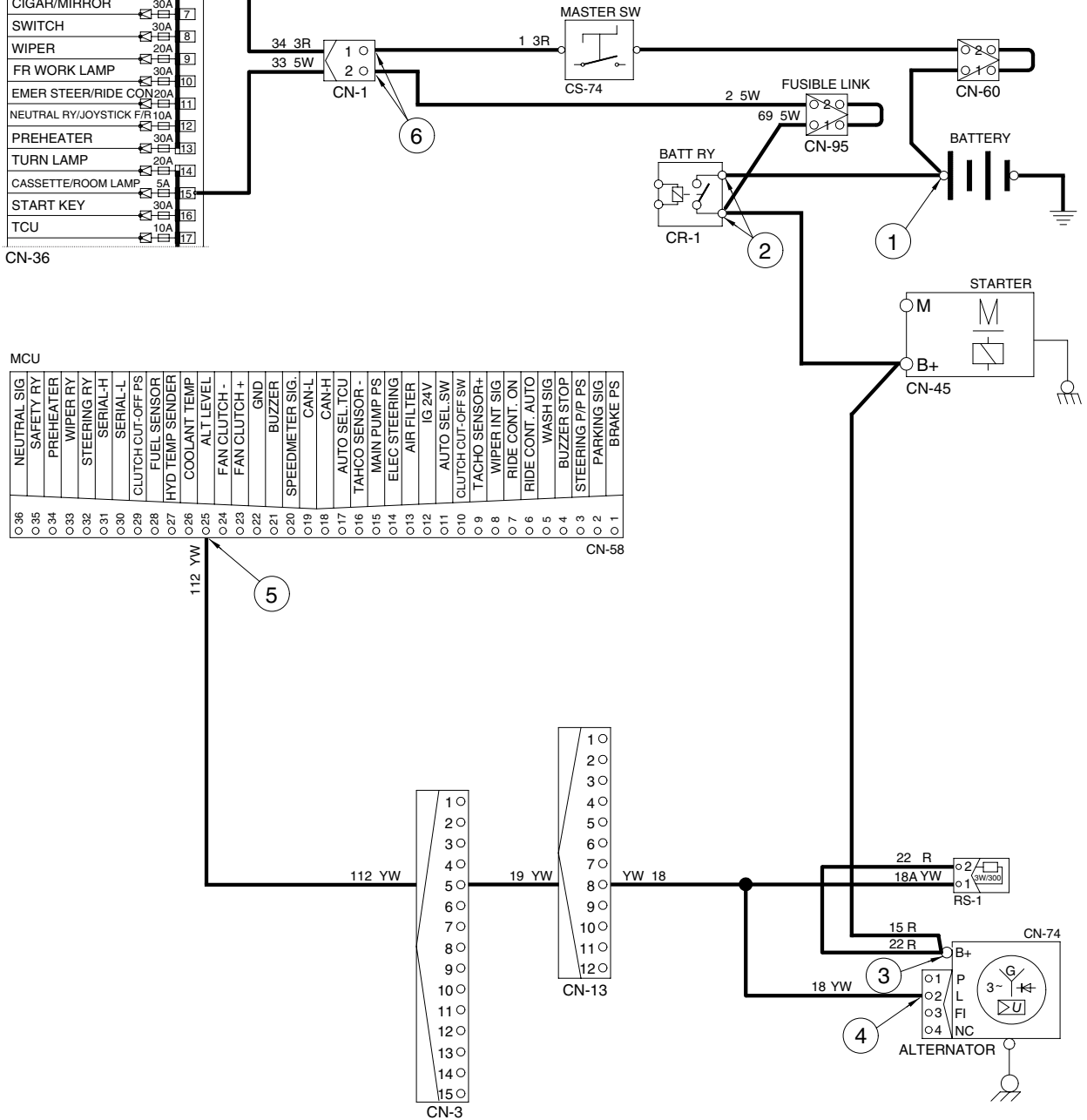

7607AEL07

6. ELECTRIC PARKING, DECLUTCH CIRCUIT

1) OPERATING FLOW

(1) Parking OFF

Fuse box (No.8) → Parking switch OFF → [CS-17(6)→(8)] → Parking solenoid ON (Activated)
 → Parking brake released (By hydraulic pressure)
 → [CS-17(5)→(7)] → T/M control unit [CN-157(21)]

(2) Parking ON

Fuse box (No.8) → Parking switch ON → Parking solenoid [CN-71] OFF
 → Parking brake applied [By spring force]

(3) Declutch ON

Fuse box (No.8) → Clutch cut-off switch ON → Clutch cut-off switch [CS-42(5)→(1)]
 → MCU [CN-58(10)→(29)] → Service brake applied → Service brake pressure switch
 ON [CD-5] → T/M control unit [CN-157(66)] → Declutch

2) CHECK POINT

Engine	Key switch	Check point	Voltage
Running	ON	① - GND (Parking switch input) ② - GND (Parking switch output) ③ - GND (Parking switch input) ④ - GND (Parking switch output) ⑤ - GND (Parking solenoid) ⑥ - GND (Pressure switch clutch cut-off)	20~25V

※ GND : Ground

ELECTRIC PARKING, DECLUTCH CIRCUIT

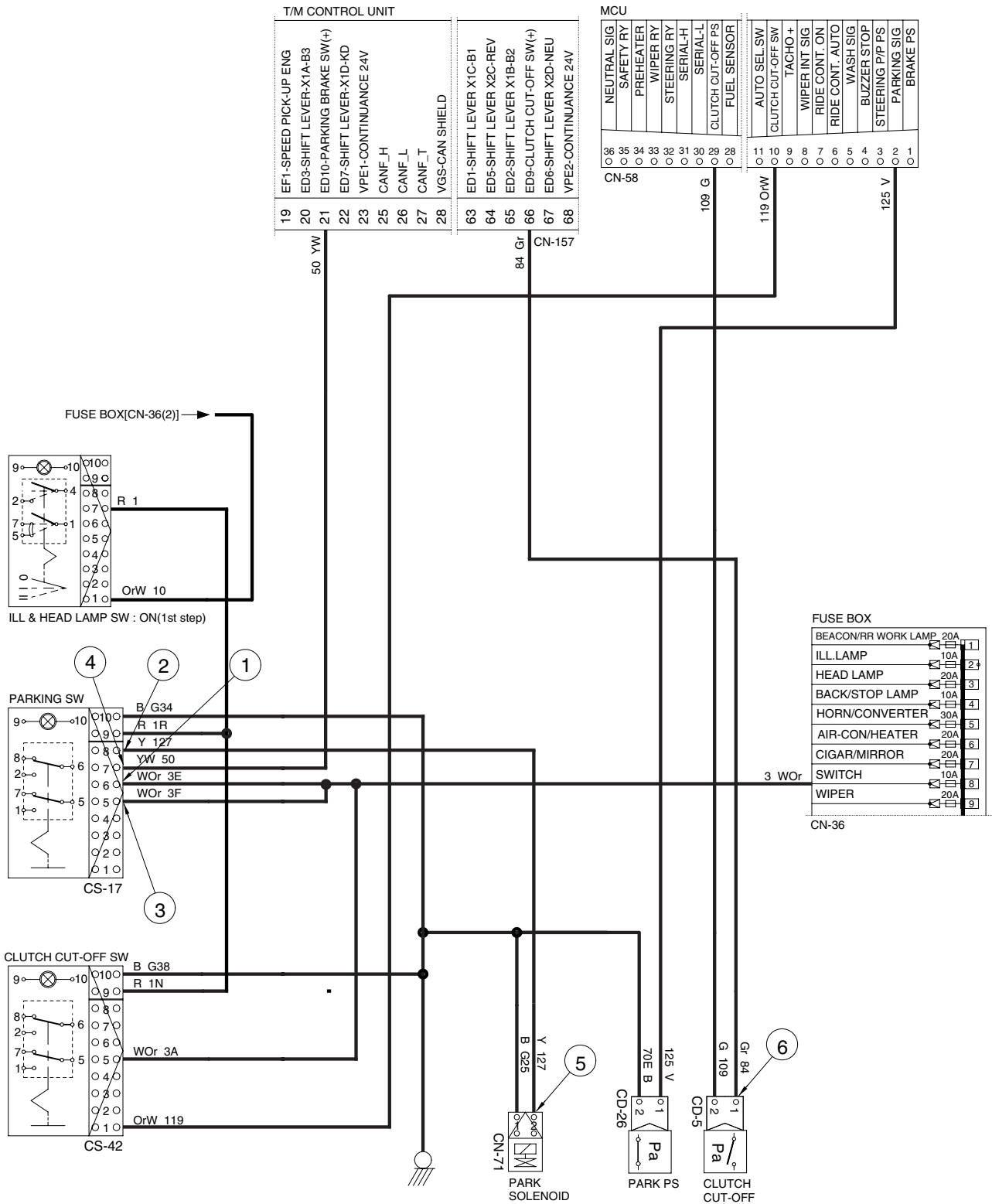

7. WIPER AND WASHER CIRCUIT

1) OPERATING FLOW

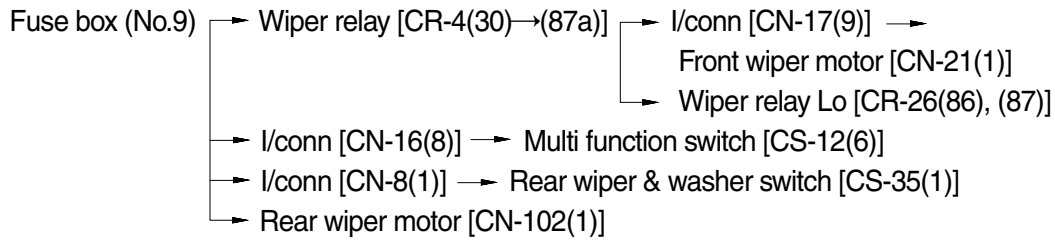

(1) Front washer switch ON

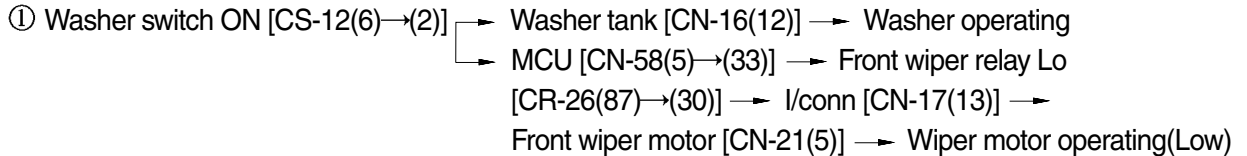

(2) Front wiper switch ON

① INT position

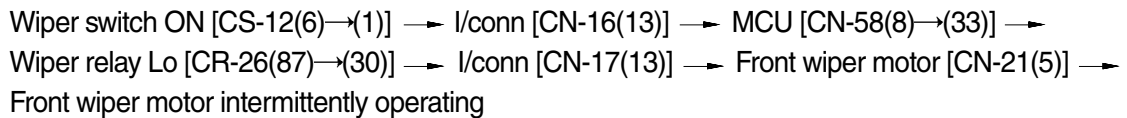

② Lo position

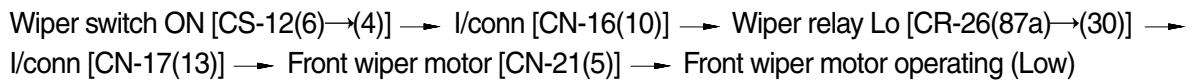

③ Hi position

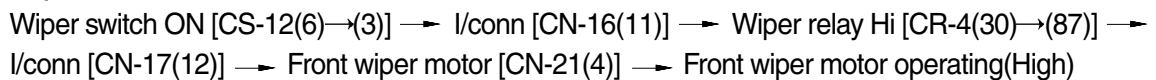

(3) Auto-parking(When switch OFF)

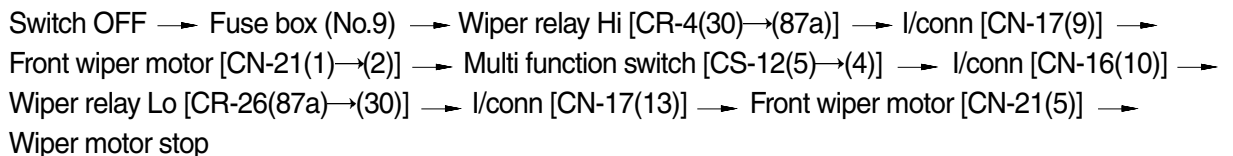

(4) Rear wiper and washer switch

① Wiper switch ON(1st step)

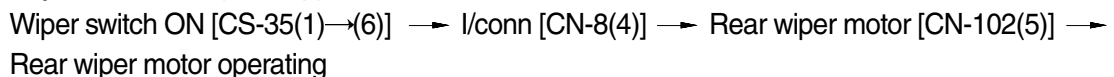

② Washer switch ON(2nd step)

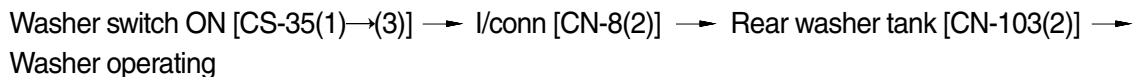

2) CHECK POINT

Condition	Check point	
Engine : Stop Key switch : ON Voltage : 20~25V	① - GND (Front wiper switch power input)	⑥ - GND (Wiper relay power input)
	② - GND (Rear wiper switch power input)	⑦ - GND (Front washer power output)
	③ - GND (Wiper relay power input)	⑧ - GND (Rear washer power output)
	④ - GND (Front wiper motor Lo power input)	⑨ - GND (Front wiper motor power output)
	⑤ - GND (Front wiper motor High power input)	⑩ - GND (Rear wiper motor power output)

※ GND : Ground

WIPER AND WASHER CIRCUIT

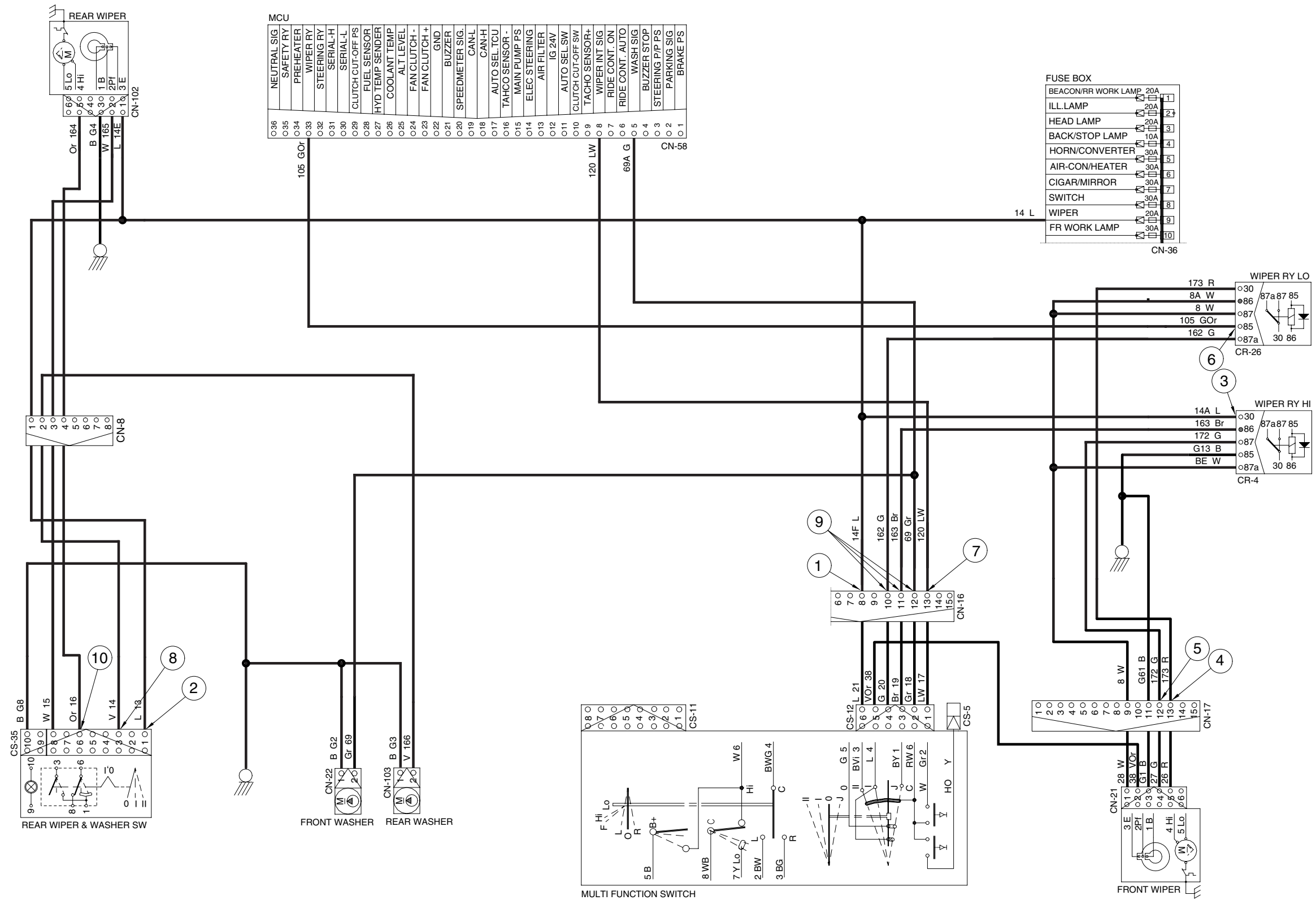

HAZARD, TURN AND ROTARY CIRCUIT

