

SECTION 6 WORK EQUIPMENT

Group 1 Structure and Function	6-1
Group 2 Operational Checks and Troubleshooting	6-33
Group 3 Tests and Adjustments	6-44
Group 4 Disassembly and Assembly	6-59

SECTION 6 WORK EQUIPMENT

GROUP 1 STRUCTURE AND FUNCTION

1. HYDRAULIC SYSTEM OUTLINE

The loader hydraulic system is a pilot operated, open center system which is supplied with flow from the fixed displacement main hydraulic pump.

The pilot control system is a low pressure, closed center hydraulic system which is supplied with flow from the first (steering) pump.

The loader system components are :

- Main pump
- Main control valve
- Bucket cylinder
- Boom cylinders
- Pilot supply unit
- Remote control valve (Pilot control valve)
- Safety valve

The pilot supply unit consists of the pressure reducing valve, relief valve and accumulator.

Flow from the main hydraulic pump not used by the steering system leaves the steering valve EF port.

It flows to the inlet port plate of mono block type main control valve.

The main control valve is open center system which routes flow to the boom, bucket or auxiliary cylinders (not shown) when the respective spools are shifted.

Flow from the steering pump is routed to the pilot supply unit where the steering pump outlet pressure is reduced to pilot circuit pressure. The pilot supply unit control valve flow to the remote control valve.

The remote control valve routed flow to either end of each spool valve section in the main control valve to control spool stroke.

A accumulator mounted on pilot supply unit supplies a secondary pressure source to operated remote control valve so the boom can be lowered if the engine is off.

The return circuit for the main hydraulic system have return filter inside the hydraulic tank. The return filter uses a filter element and a bypass valve. The bypass valve is located in the upside of filter.

2. HYDRAULIC CIRCUIT

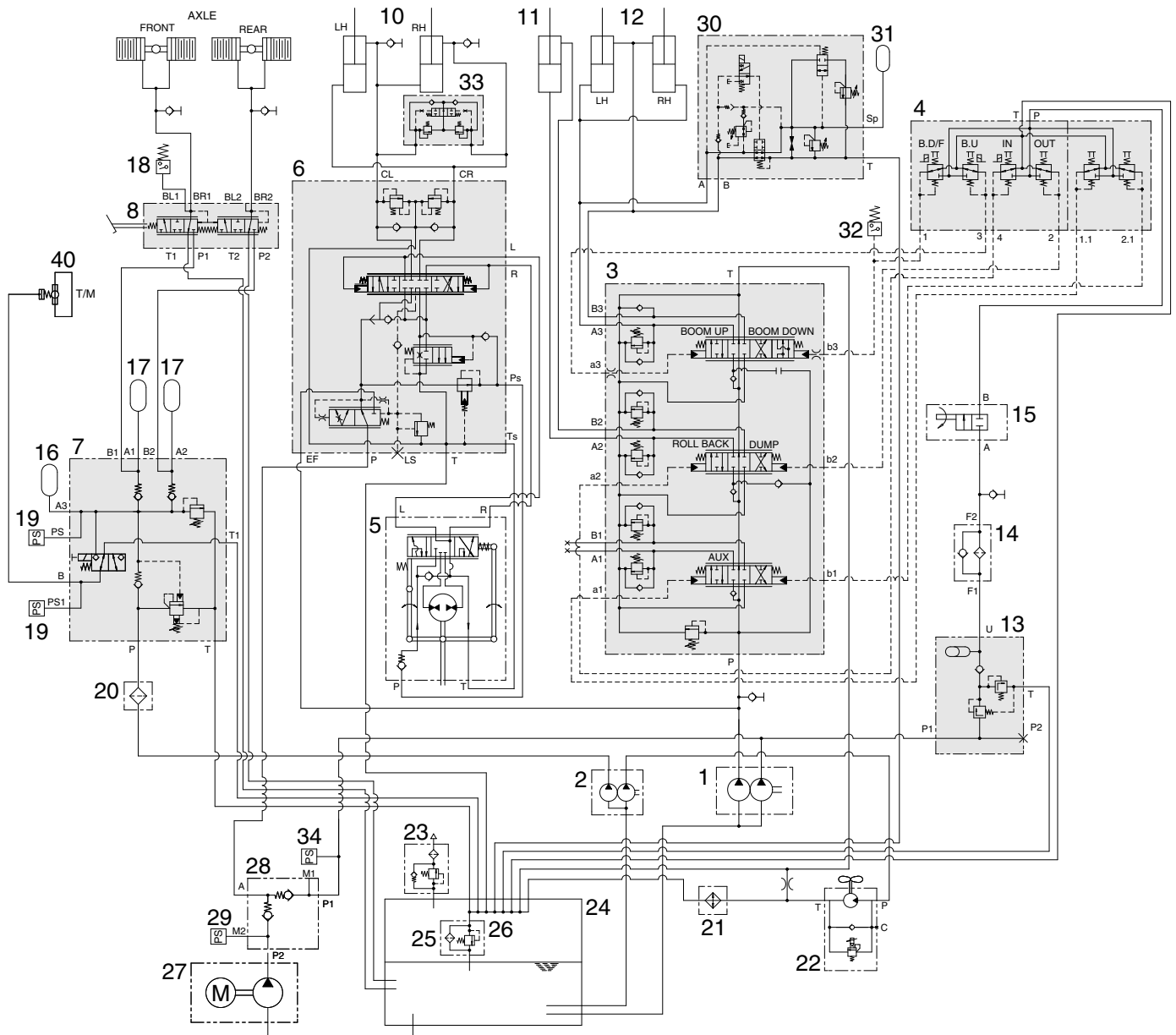

7579SM6WE01

- | | | | | | |
|----|----------------------|----|-----------------|----|--------------------------|
| 1 | Main pump | 14 | Line filter | 26 | Bypass valve |
| 2 | Fan & brake pump | 15 | Safety valve | 27 | Pump motor (opt) |
| 3 | Main control valve | 16 | Accumulator | 28 | Check valve (opt) |
| 4 | Remote control valve | 17 | Accumulator | 29 | Pressure sensor (opt) |
| 5 | Steering unit | 18 | Pressure switch | 30 | Ride control valve (opt) |
| 6 | Steering valve | 19 | Pressure sensor | 31 | Accumulator (opt) |
| 7 | Cut off valve | 20 | Line filter | 32 | Pressure switch (opt) |
| 8 | Brake valve | 21 | Oil cooler | 33 | Cushion valve |
| 10 | Steering cylinder | 22 | Fan motor | 34 | Pressure sensor |
| 11 | Bucket cylinder | 23 | Air breather | 40 | Parking brake on T/M |
| 12 | Boom cylinder | 24 | Hydraulic tank | | |
| 13 | Pilot supply unit | 25 | Return filter | | |

3. WORK EQUIPMENT HYDRAULIC CIRCUIT

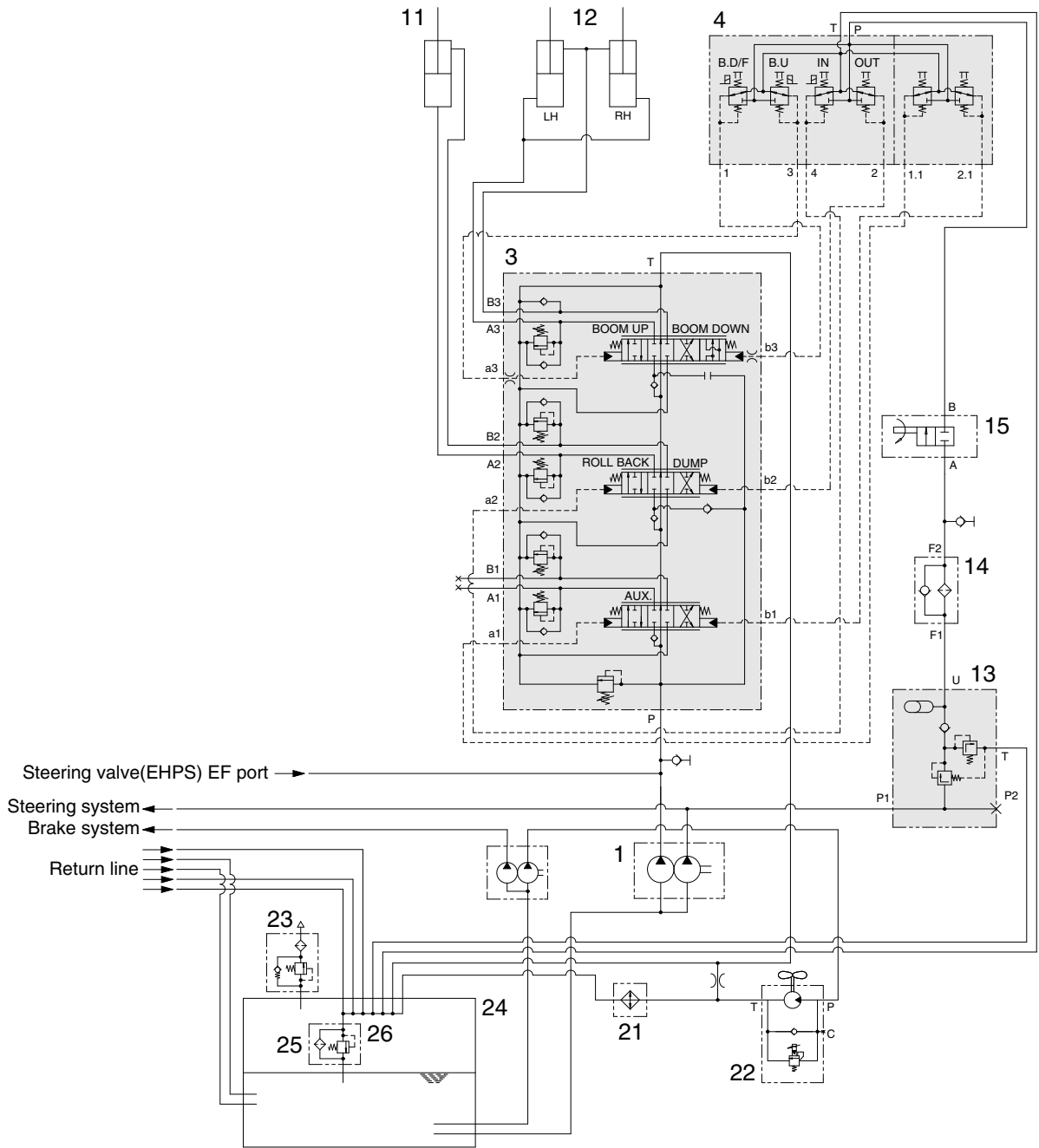

7579S6WE02

- | | | | | | |
|----|----------------------|----|-------------------|----|----------------|
| 1 | Main pump | 13 | Pilot supply unit | 24 | Hydraulic tank |
| 3 | Main control valve | 14 | Line filter | 25 | Return filter |
| 4 | Remote control valve | 15 | Safety valve | 26 | Bypass valve |
| 11 | Bucket cylinder | 21 | Oil cooler | | |
| 12 | Boom cylinder | 23 | Air breather | | |

1) WHEN THE RCV LEVER IS IN THE RAISE POSITION

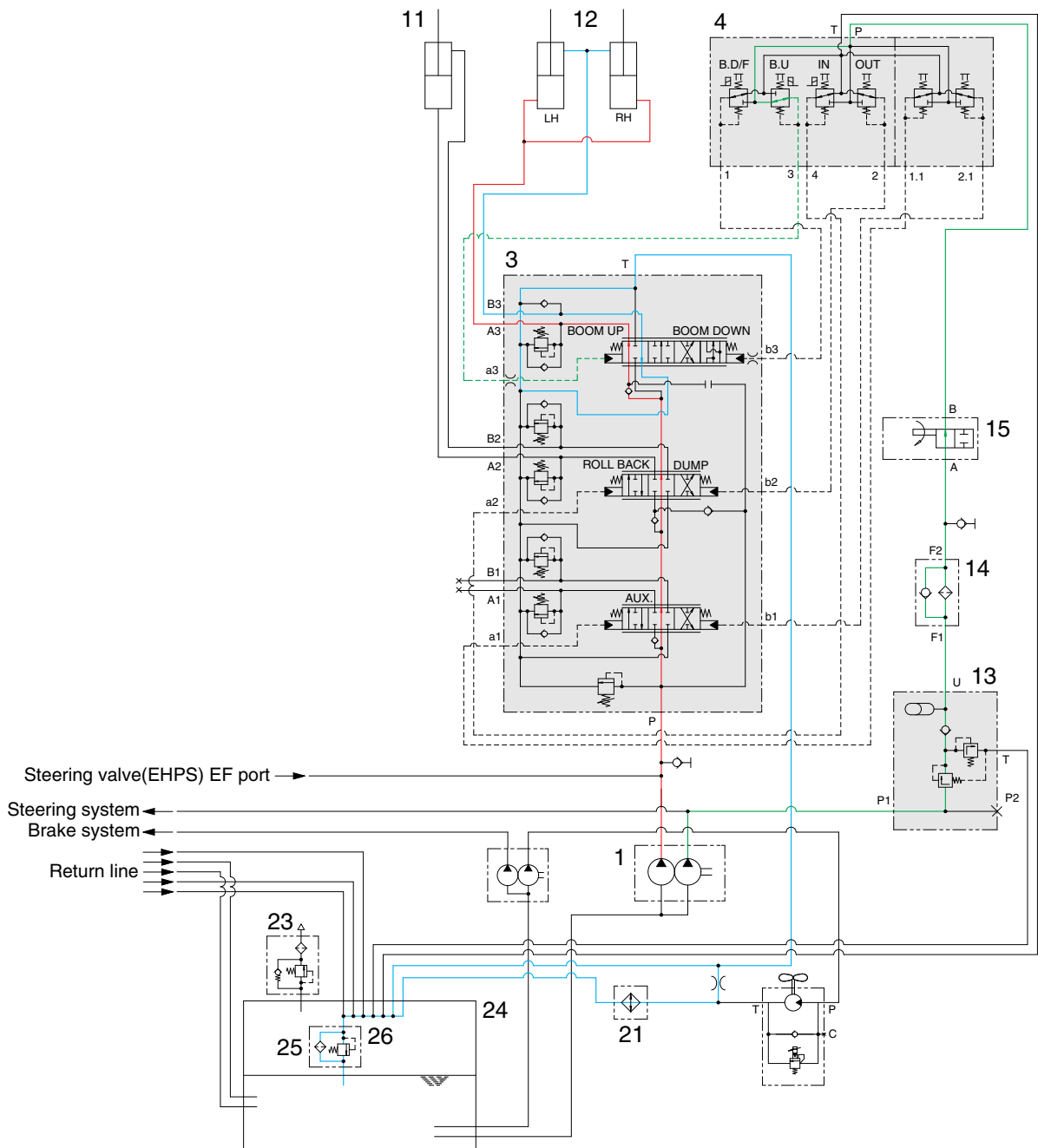

7579S6WE03

- When the RCV lever (4) is pulled back, the boom spool is moved to raise position by pilot oil pressure from port 3 of RCV.
- The oil from main pump (1) flows into main control valve (3) and then goes to the large chamber of boom cylinder (12) by pushing the load check valve of the boom spool.
- The oil from the small chamber of boom cylinder (12) returns to hydraulic oil tank (24) through the boom spool at the same time.
- When this happens, the boom goes up.

2) WHEN THE RCV LEVER IS IN THE LOWER POSITION

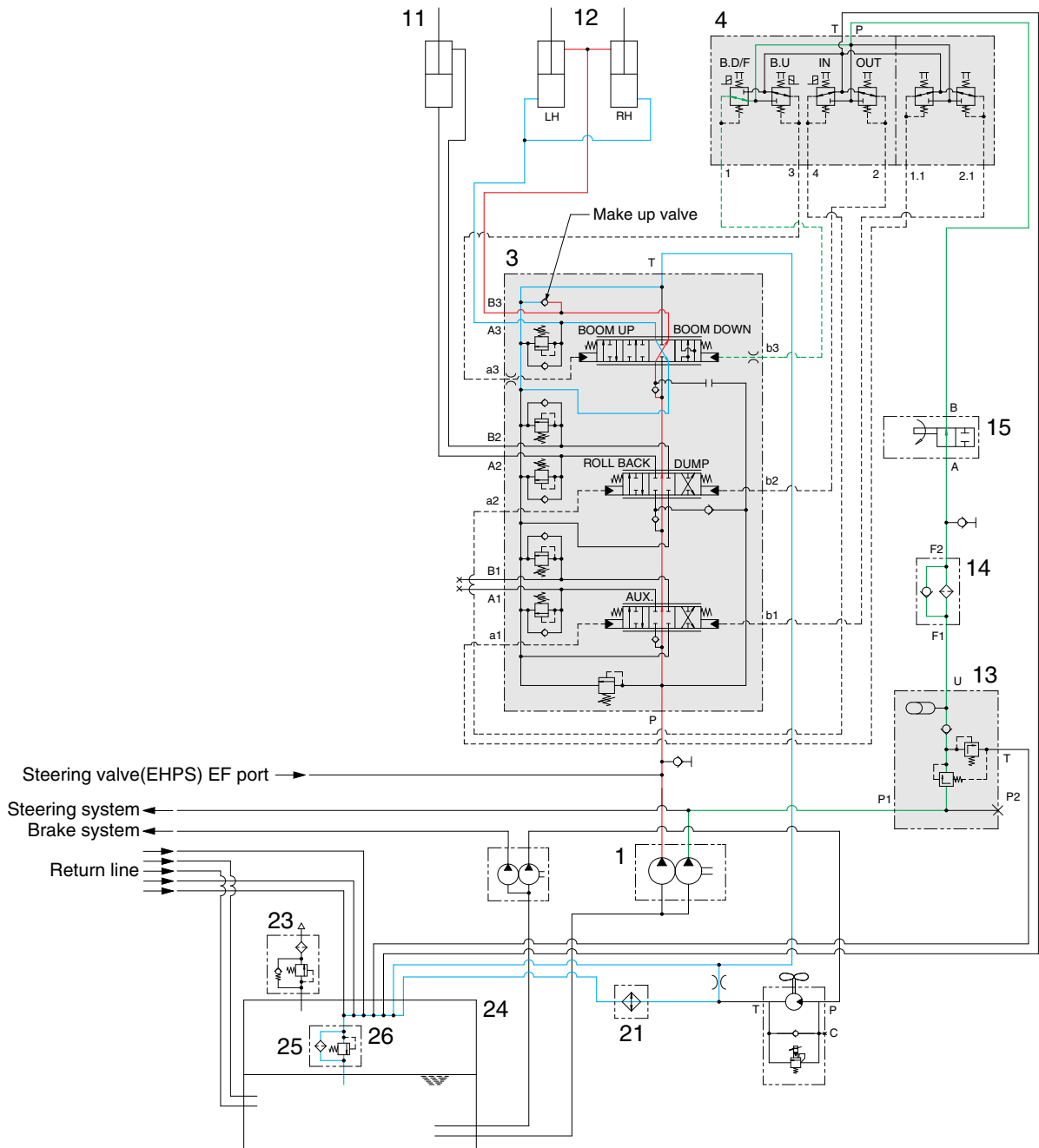

7579S6WE04

- When the RCV lever (4) is pushed forward, the boom spool is moved to lower position by pilot pressure.
- The oil from main pump (1) flows into main control valve (3) and then goes to small chamber of boom cylinder (12) by pushing the load check valve of the boom spool.
- The oil returned from large chamber of boom cylinder (12) returns to hydraulic tank (24) through the boom spool at the same time.
- When the lowering speed of boom is faster, the return oil from the large chamber of boom cylinder combines with the oil from the pump through the make up valve, and flows into the small chamber of the cylinder.

This prevents cylinder cavitation by the negative pressure when the pump flow cannot match the boom down speed.

3) WHEN THE RCV LEVER IS IN THE FLOAT POSITION

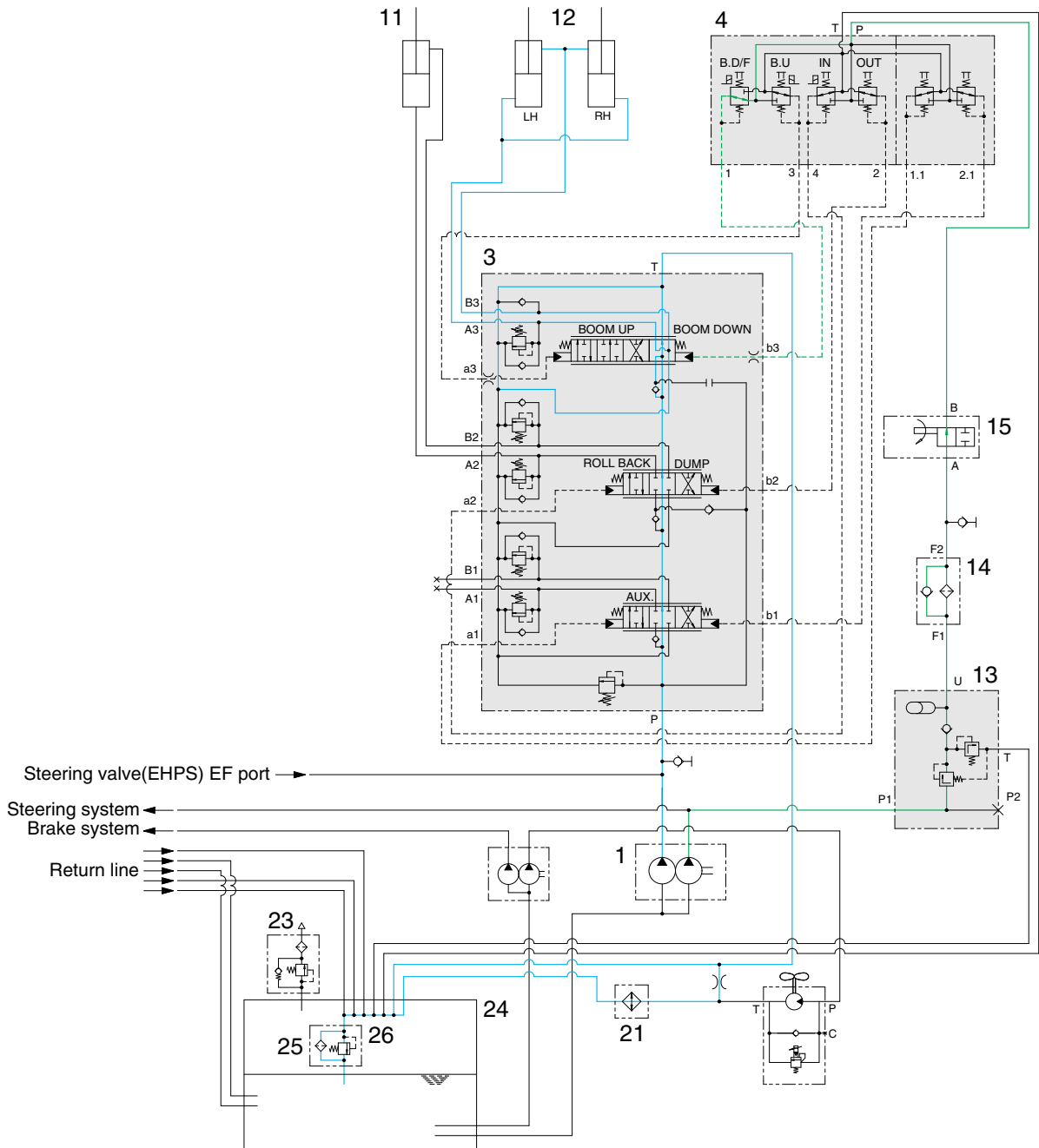

7579S6WE05

- When the RCV lever (4) is pushed further forward from the lower position, the pilot pressure reaches to 13~15bar, then the boom spool is moved to floating position.
- The work ports (A3), (B3) and the small chamber and the large chamber are connected to the return passage, so the boom will be lowered due to it's own weight.
- In this condition, when the bucket is in contact with the ground, it can be move up and down in accordance with the shape of the ground.

4) WHEN THE RCV LEVER IS IN THE DUMP POSITION

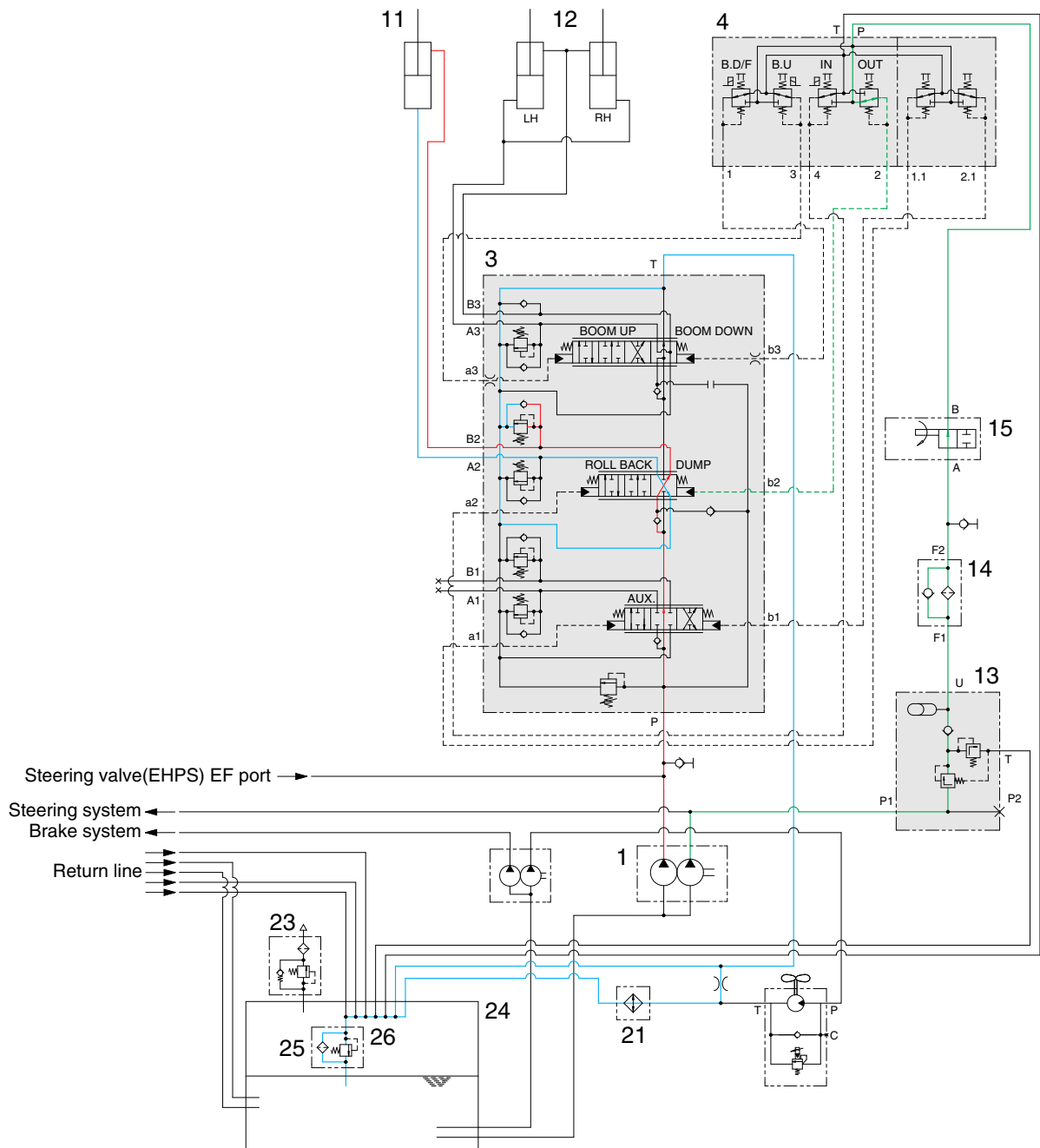

7579S6WE06

- If the RCV lever (4) is pushed right, the bucket spool is moved to dump position by pilot oil pressure from port 2 of RCV.
- The oil from main pump (1) flows into main control valve (3) and then goes to the small chamber of bucket cylinder (11) by pushing the load check valve of the bucket spool.
- The oil at the large chamber of bucket cylinder (11) returns to hydraulic tank (24).
- When this happens, the bucket is dumped.
- When the dumping speed of bucket is faster, the oil returned from the large chamber of bucket cylinder combines with the oil from the pump, and flows into the small chamber of the cylinder. This prevents cylinder cavitation by the negative pressure when the pump flow cannot match the bucket dump speed.

5) WHEN THE RCV LEVER IS IN THE ROLL BACK (retract) POSITION

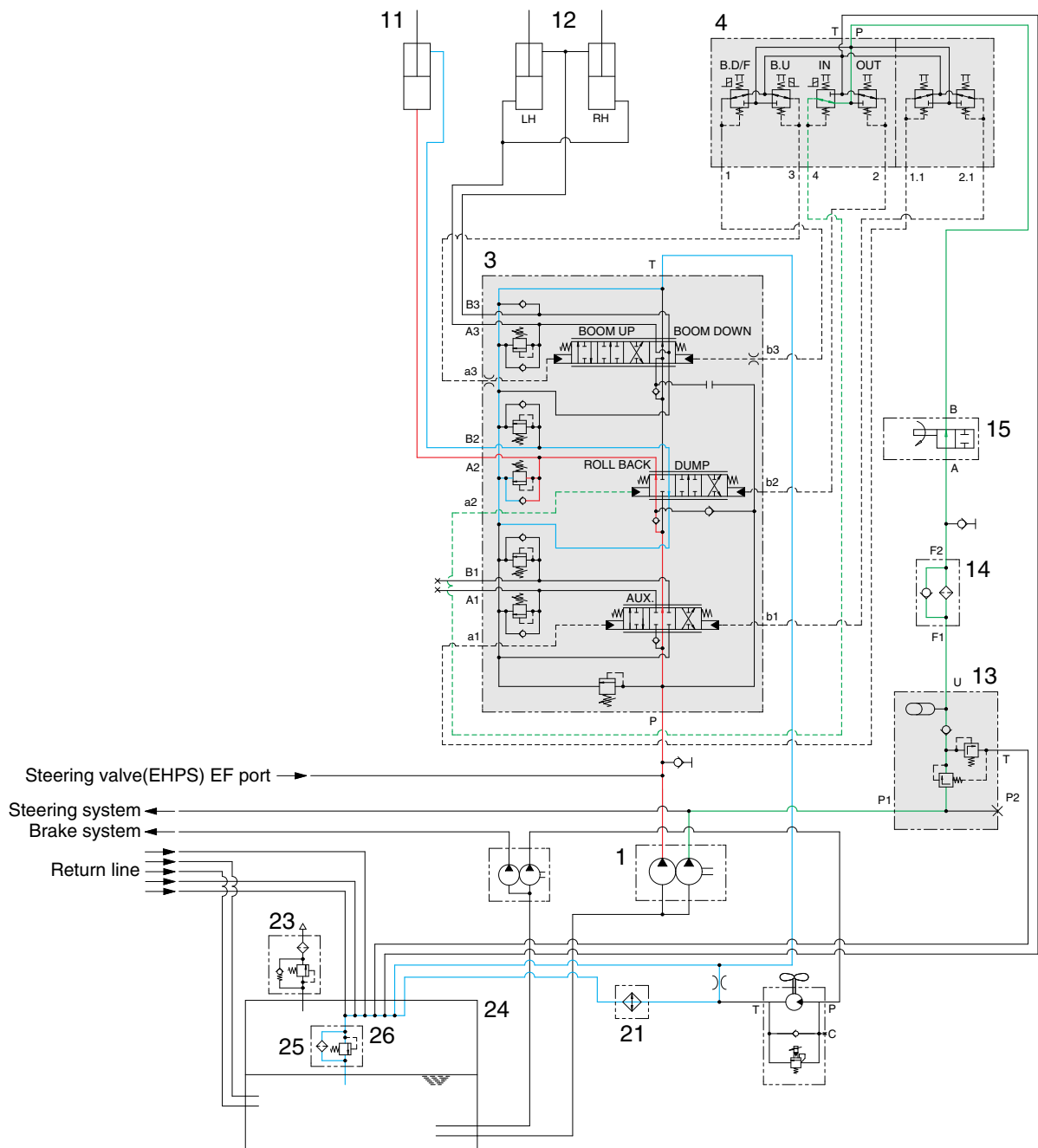

7579S6WE07

- If the RCV lever (4) is pulled left, the bucket spool is moved to roll back position by pilot oil pressure from port 4 of RCV.
- The oil from main pump (1) flows into main control valve (3) and then goes to the large chamber of bucket cylinder by pushing the load check valve of the bucket spool.
- The oil at the chamber of bucket cylinder (11) returns to hydraulic tank (24).
- When this happens, the bucket roll back.

6) WHEN THE RCV LEVER IS IN THE HOLD POSITION

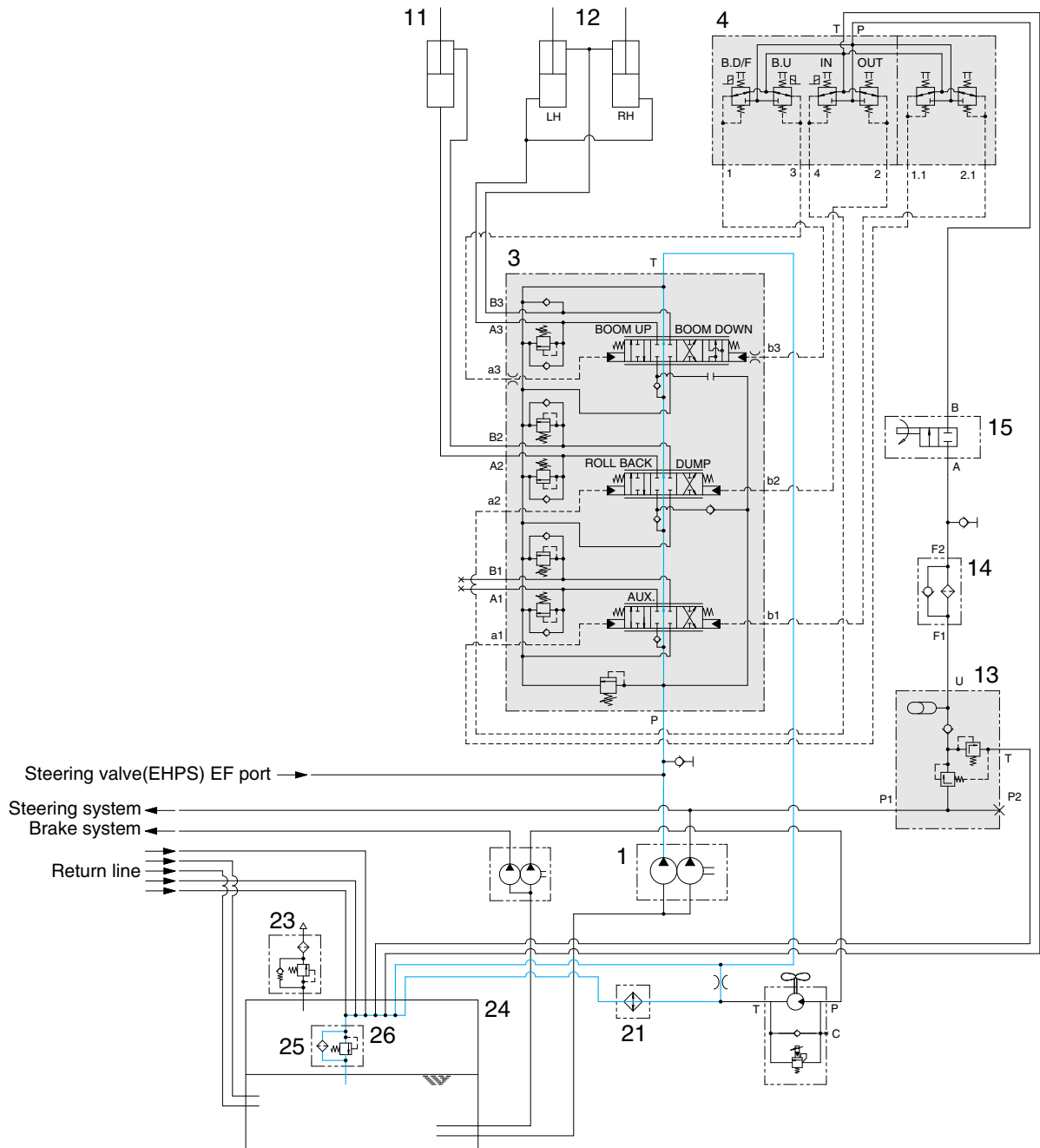

7579S6WE08

- The oil from main pump (1) flows into main control valve (3)
In this time, the bucket spool, the boom spool and the boom float spool are in neutral position, then
- the oil supplied to main control valve (3) returns into hydraulic tank (24) through center bypass circuit of each spool.
- In this condition, each cylinder keeps the neutral position, so the boom and the bucket is held.

4. MAIN PUMP

1) STRUCTURE

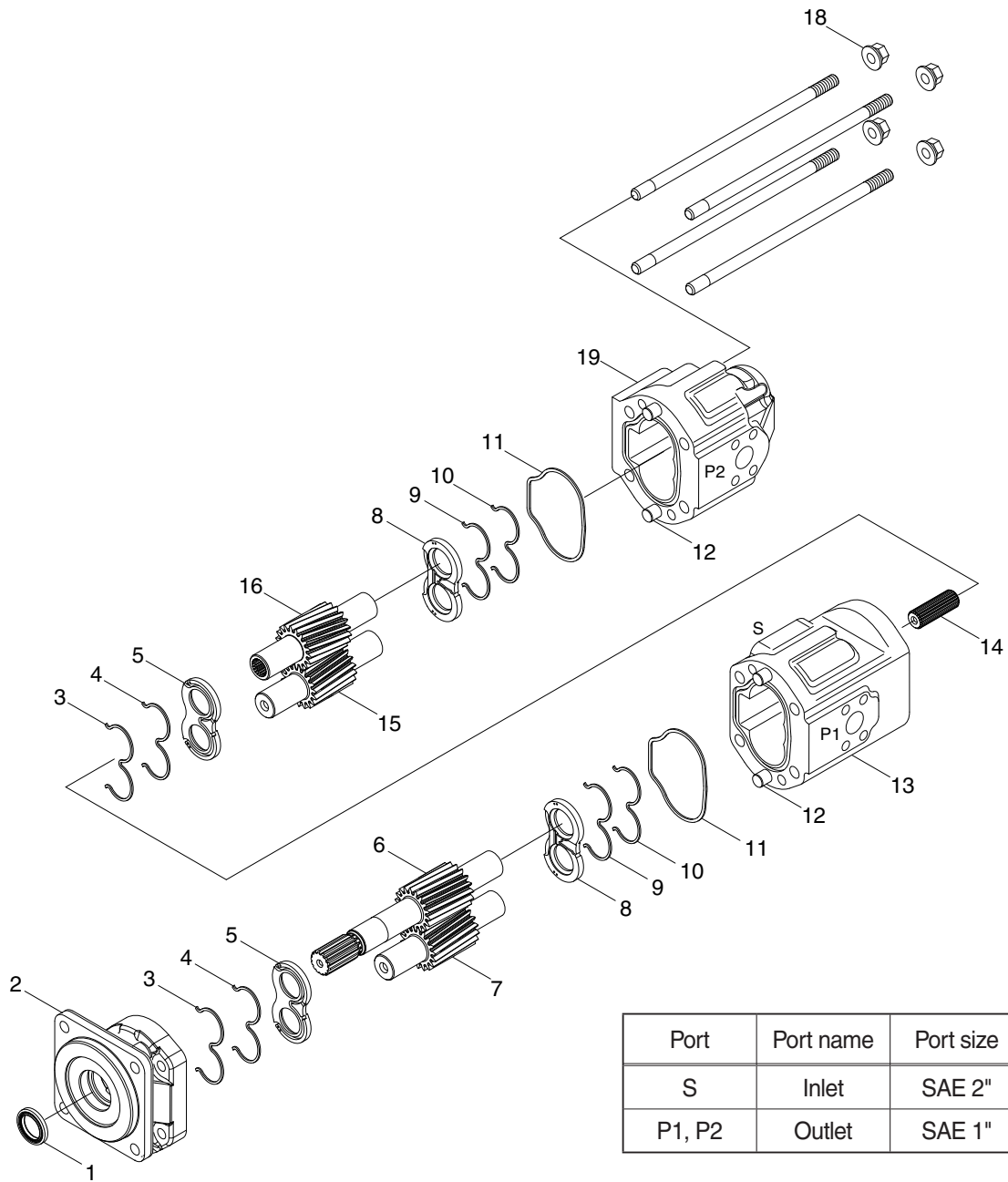

Port	Port name	Port size
S	Inlet	SAE 2"
P1, P2	Outlet	SAE 1"

7579SM6WE29

- | | | | | | |
|---|-------------------|----|-----------------|----|------------------|
| 1 | Shaft seal | 8 | Wearplate | 15 | Rear driven gear |
| 2 | Adapter | 9 | O-ring seal | 16 | Rear drive gear |
| 3 | Back up seal | 10 | Back up seal | 17 | Stud |
| 4 | O-ring seal | 11 | Interface seal | 18 | Flanged nut |
| 5 | Wearplate | 12 | Dowel | 19 | Rear body |
| 6 | Front drive gear | 13 | Front body | | |
| 7 | Front driven gear | 14 | Spline coupling | | |

2) OPERATION

The main hydraulic pump is a fixed displacement gear type pump. The pump is drive at engine speed by the transmission. The pump shafts are supported by shaft seal (1) adapter (2), front body (13) and rear body (19). The wearplate (5, 8) are located between the gear surface and adapter (1), rear body (19) and front body (13).

As the drive gear (6) and (16) turns the idler gears (7, 15), the gear teeth come out of mesh. Oil flows from the hydraulic tank through the inlet into the cavity between the gear teeth. As the gears continue to rotate, the oil becomes trapped between the gear teeth and front body (13).

The trapped oil is then carried to the pump outlet. Oil is forced out the outlet to supply the hydraulic function. As the gears re-mesh, they form a seal to prevent oil from flowing between the gears and back to the inlet.

The pump uses outlet pressure oil to load the wearplate (5, 8) against the gear faces. This controls internal leakage to maintain pump displacement.

Outlet pressure fills the area bounded by the pressure balance moulded seals (3, 4) to force the wearplate against the high pressure area or the gear faces.

5. REMOTE CONTROL VALVE

1) STRUCTURE

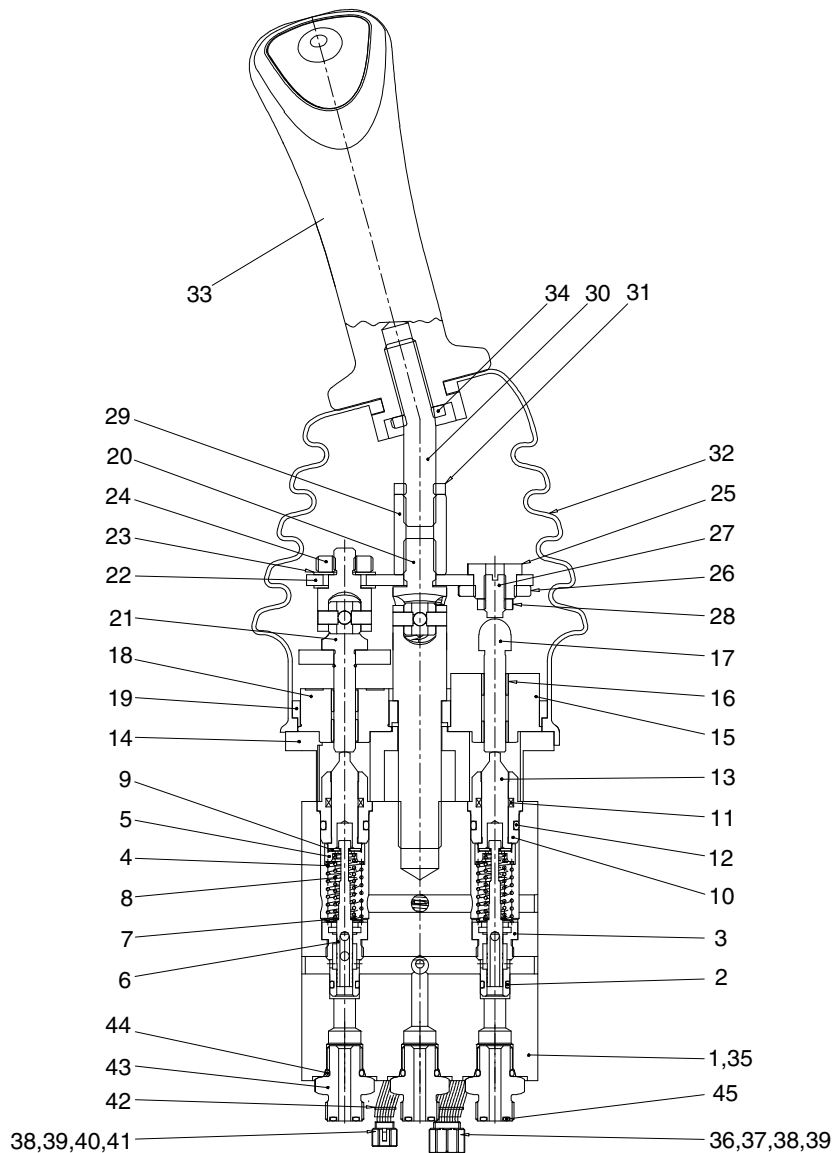

7607B6WE28

1	Body	16	Bushing	31	Nut
2	O-ring	17	Rod	32	Boot
3	Plug	18	Magnet	33	Handle assy
4	Spring	19	Plate	34	Nut
5	Spring seat	20	Joint assy	35	Plug
6	Spool	21	Joint assy	36	6 pin connector
7	Spring seat	22	Plate	37	Rear holder
8	Spring	23	Washer	38	Terminal
9	Stopper	24	Nut	39	Seal wire
10	Plug	25	Plug	40	2 pin connector
11	Rod seal	26	Nut	41	Rear holder
12	O-ring	27	Set screw	42	Clip band
13	Push rod	28	Nut	43	Connector
14	Plate	29	Nut	44	O-ring
15	Rod stopper	30	Handle bar	45	O-ring

2) OPERATION

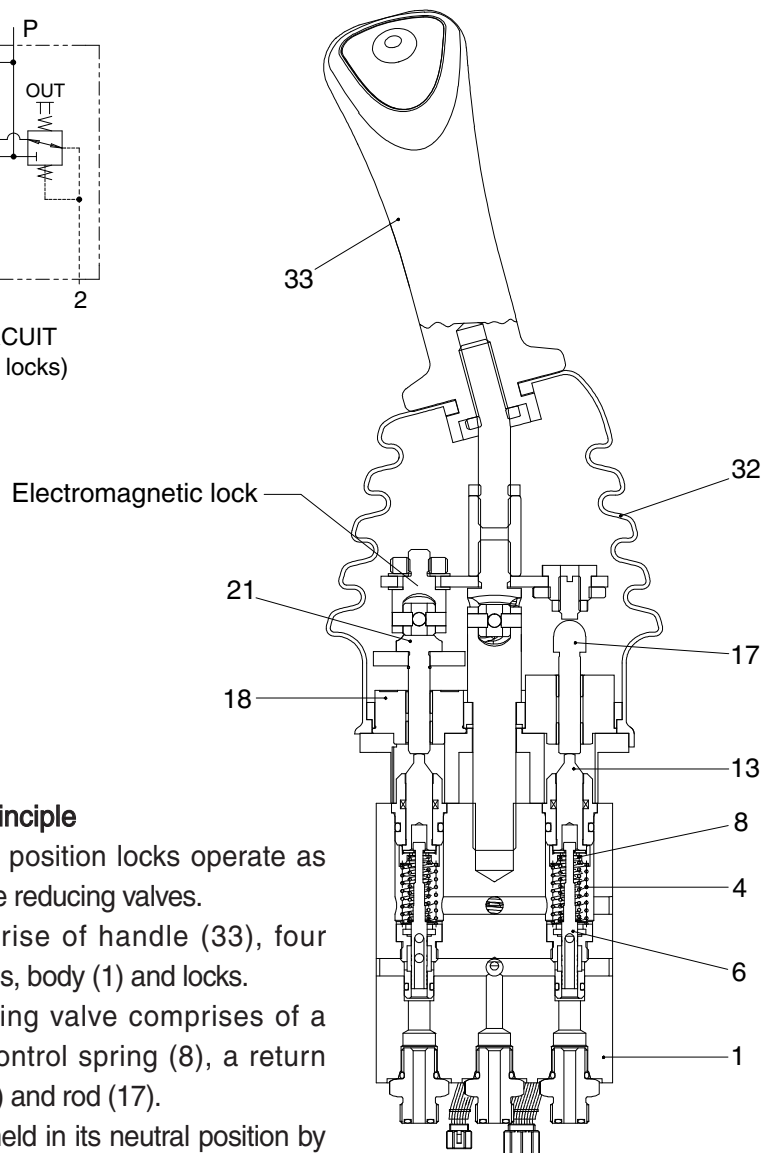
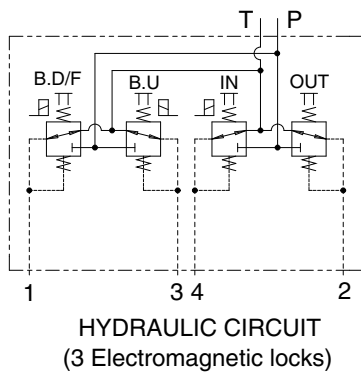

(1) Hydraulic functional principle

Pilot devices with end position locks operate as direct operated pressure reducing valves.

They basically comprise of handle (33), four pressure reducing valves, body (1) and locks.

Each pressure reducing valve comprises of a control spool (6), a control spring (8), a return spring (4), push rod (13) and rod (17).

At rest, handle (33) is held in its neutral position by return springs (4). Ports (1, 2, 3, 4) are connected to tank port T via drilling.

When handle (33) is deflected, rod (17) is pressed against return spring (4) and control spring (8). Control spring (8) initially moves control spool (6) downwards and closes the connection between the relevant port and tank port T. At the same time the relevant port is connected to port P via drilling. The control phase starts as soon as control spool (6) finds its balance between the force from control spring (8) and the force, which results from the hydraulic pressure in the relevant port (ports 1, 2, 3 or 4).

Due to the interaction between control spool (6) and control spring (8) the pressure in the relevant port is proportional to the stroke of rod (17) and hence to the position of handle (33).

This pressure control which is dependent on the position of the handle (33) and the characteristics of the control spring permits the proportional hydraulic control of the main directional valves and high response valves for hydraulic pumps.

A rubber boot (32) protects the mechanical components in the housing from contamination.

7607B6WE27

(2) End position lock

Only those control ports, for which it is necessary to hold the handle in a deflected position are equipped with end position locks.

Electromagnetic lock

When this threshold is overcome, a joint assy (21) contacts the magnet (18); if the magnet (18) is energized, then handle (33) is held in its end position by magnetic force.

This lock is released automatically when the solenoid is deenergized.

6. MAIN CONTROL VALVE

1) STRUCTURE

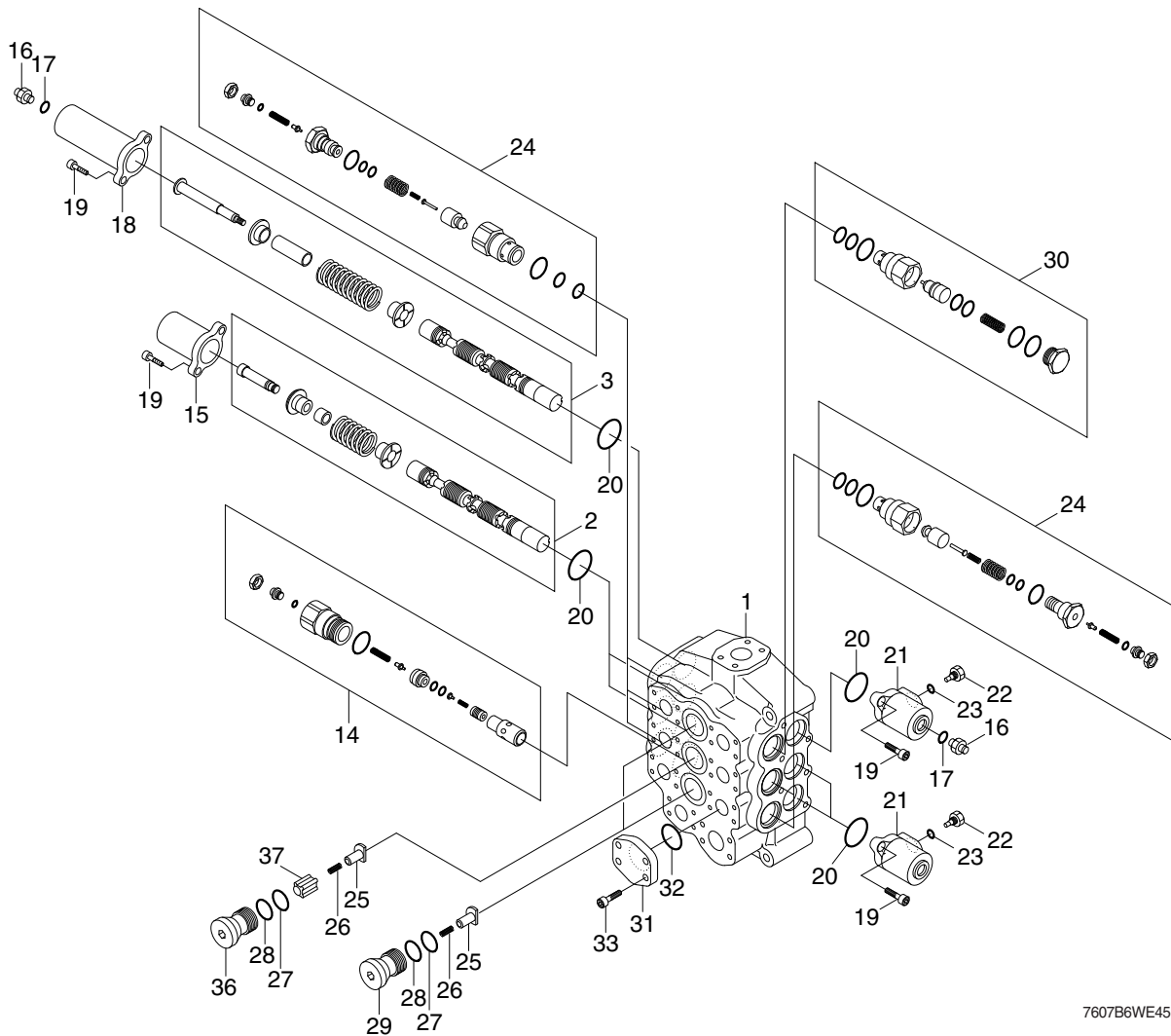

7607B6WE45

1	Block	20	O-ring	29	Plug
2	Spool assembly	21	Pilot cap (C)	30	Make up valve
3	Spool assembly	22	Guide plug	31	Cover
14	Main relief valve	23	O-ring	32	O-ring
15	Pilot cap (A)	24	Overload relief valve	33	Socket bolt
16	Nipple	25	Check	36	Plug
17	O-ring	26	Spring	37	Check
18	Pilot cap (B)	27	O-ring		
19	Wrench bolt	28	Back up ring		

STRUCTURE

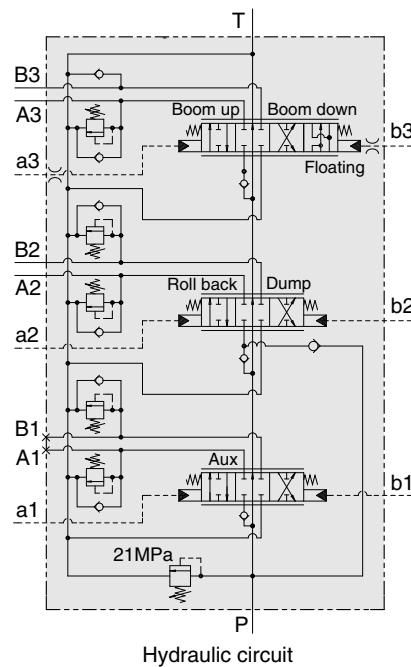
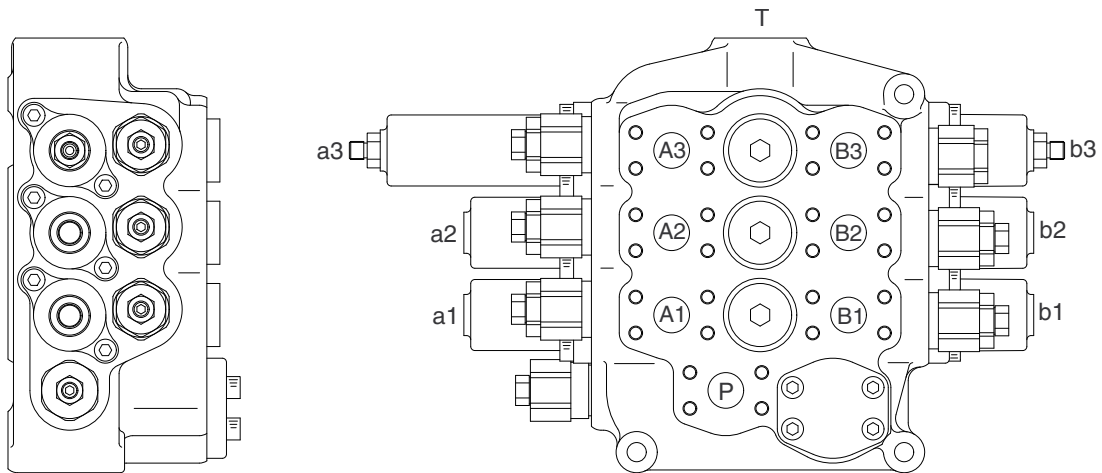

7607B6WE10

Port	Port name	Port size
P	From main pump	1" Split flange
T	To hydraulic tank	1-1/4" Split flange
A2, B2	To bucket cylinder port	1" Split flange
A3, B3	To boom cylinder port	1" Split flange
a3, b3	Boom pilot port	PF 3/8" Fitting
a2, b2	Bucket pilot port	PF 3/8 O-ring boss

2) BOOM SECTION OPERATION

(1) Spool in neutral

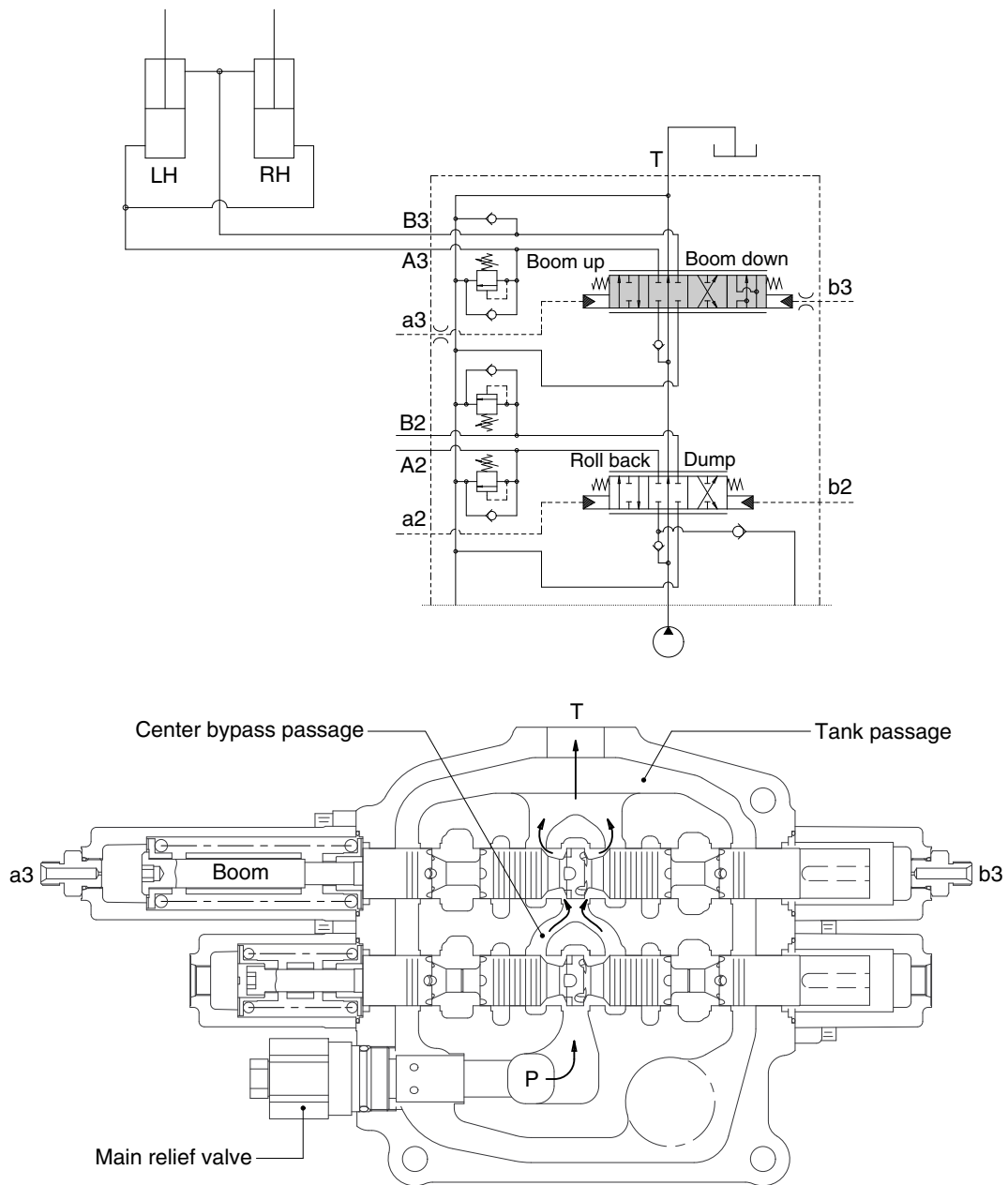

7607WE11

When the boom plunger is in neutral position, oil from the pump flows to the tank through the center bypass line.

The cylinder port (A3, B3) are shut off from the high pressure feed passage and tank passage by the boom plunger.

(2) Boom raise position

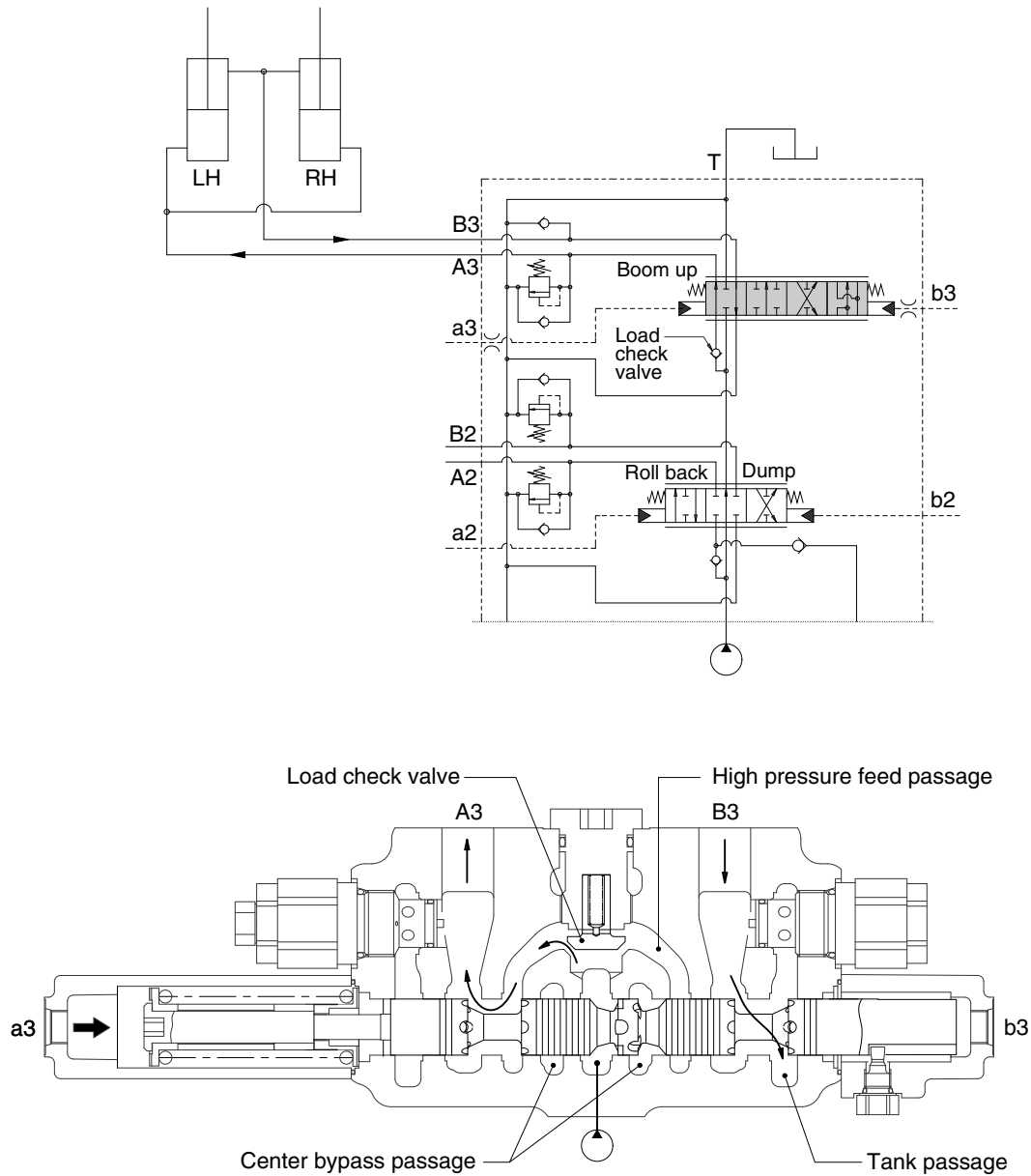

7607WE12

When the pilot pressure is led to the port (a3), the boom plunger is switched, and shut off center bypass passage.

Oil from the pump flows to the cylinder port (A3) through the load check valve and oil from the cylinder flows into the tank passage through the cylinder port (B3).

※ Load check valve

When the load pressure is higher than the pump pressure, the load check shuts off the passage between the high pressure feed passage and the center bypass passage and prevents the reverse flow from the cylinder.

(3) Boom lower position

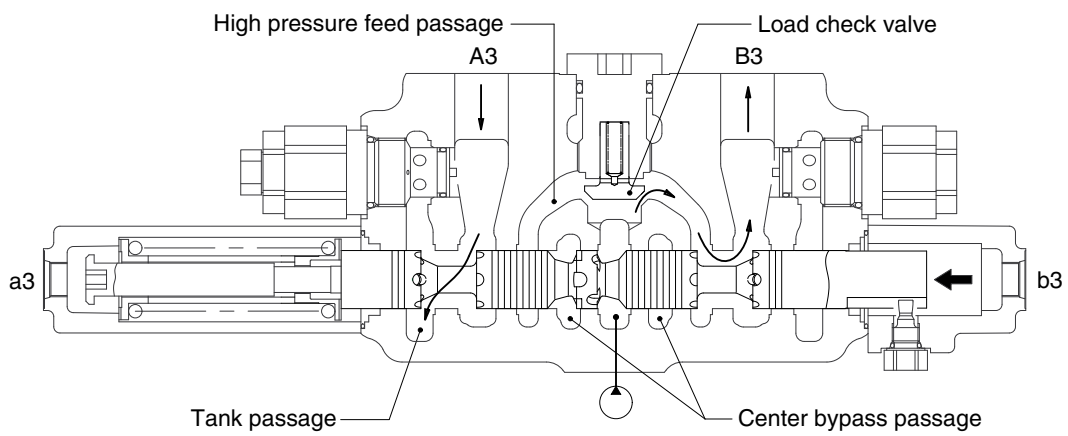
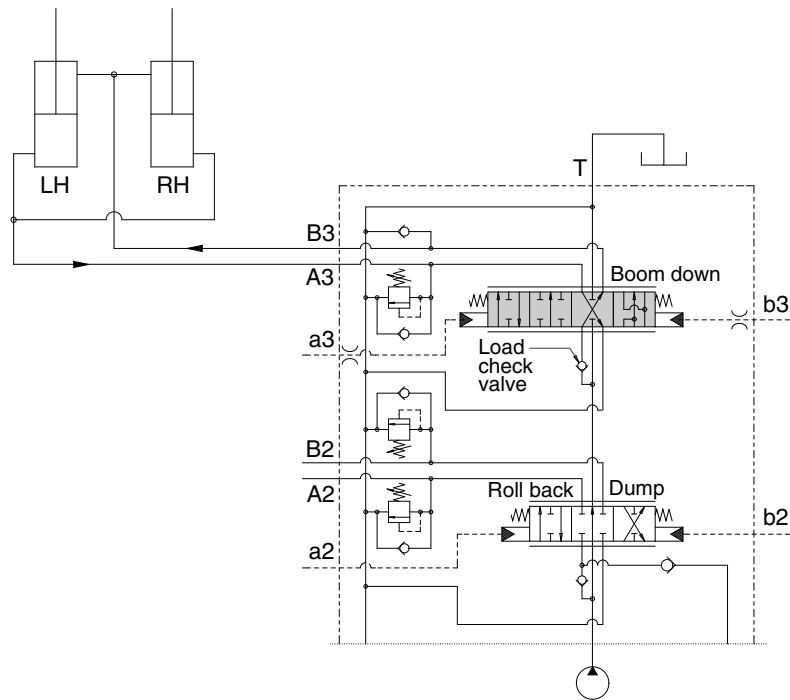

7607WE13

When the pilot pressure is led to the port (b3), the boom plunger is switched, and shut off center bypass passage. Oil from the pump flows to the cylinder port (B3), through the load check valve and oil from the cylinder flows into the tank passage through the cylinder port (A3).

(4) Boom float position

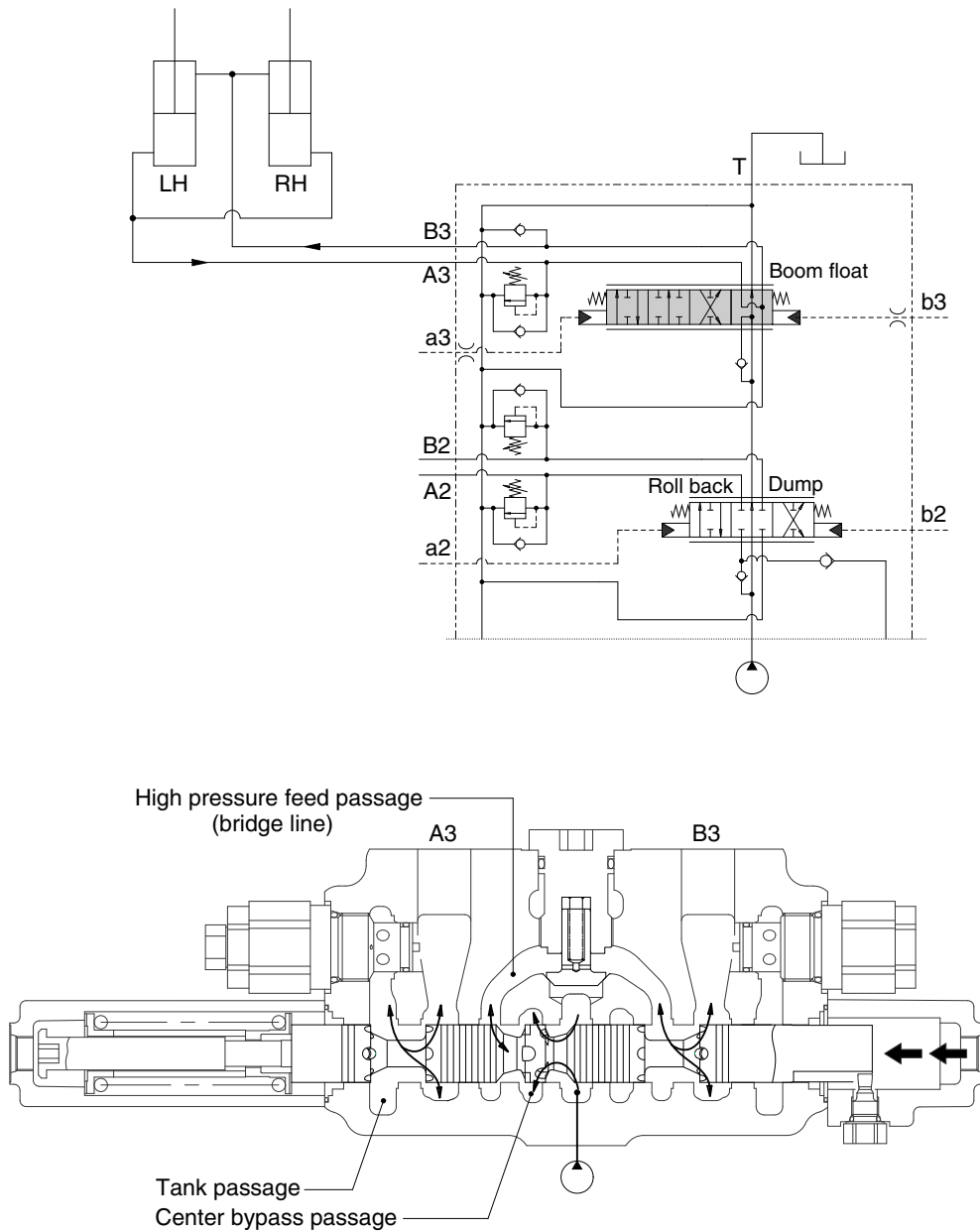

7607WE14

When the boom plunger is located in float position, the oil from the pump flows to the tank through the center bypass line.

The cylinder port (A3) is connected to the tank passage, and the cylinder port (B3) is connected to the tank passage through the bridge line. And then the both cylinder port is in float condition.

3) BUCKET SECTION OPERATION

(1) Spool in neutral

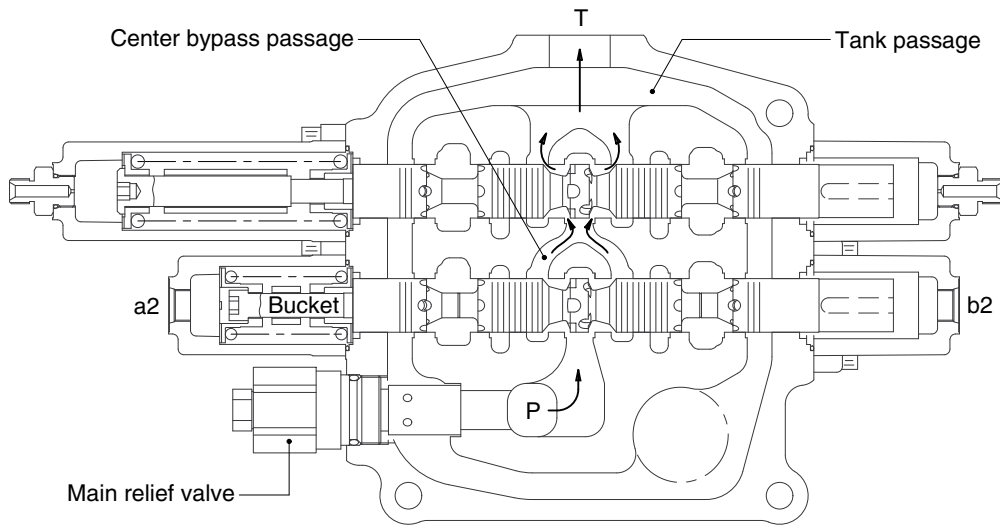
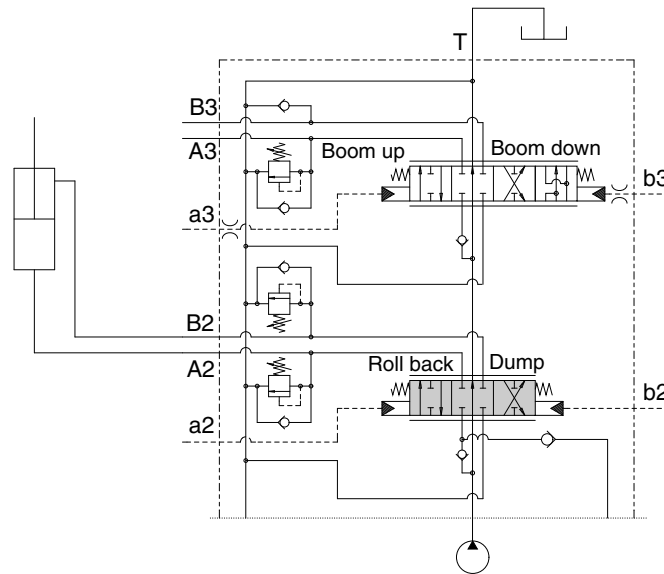

7607WE15

When the bucket plunger is in neutral position, oil from the pump flows to the tank through the center bypass line.

To cylinder port (A2, B2) are shut off from the high pressure feed passage and tank passage by the bucket plunger.

(2) Bucket rollback position

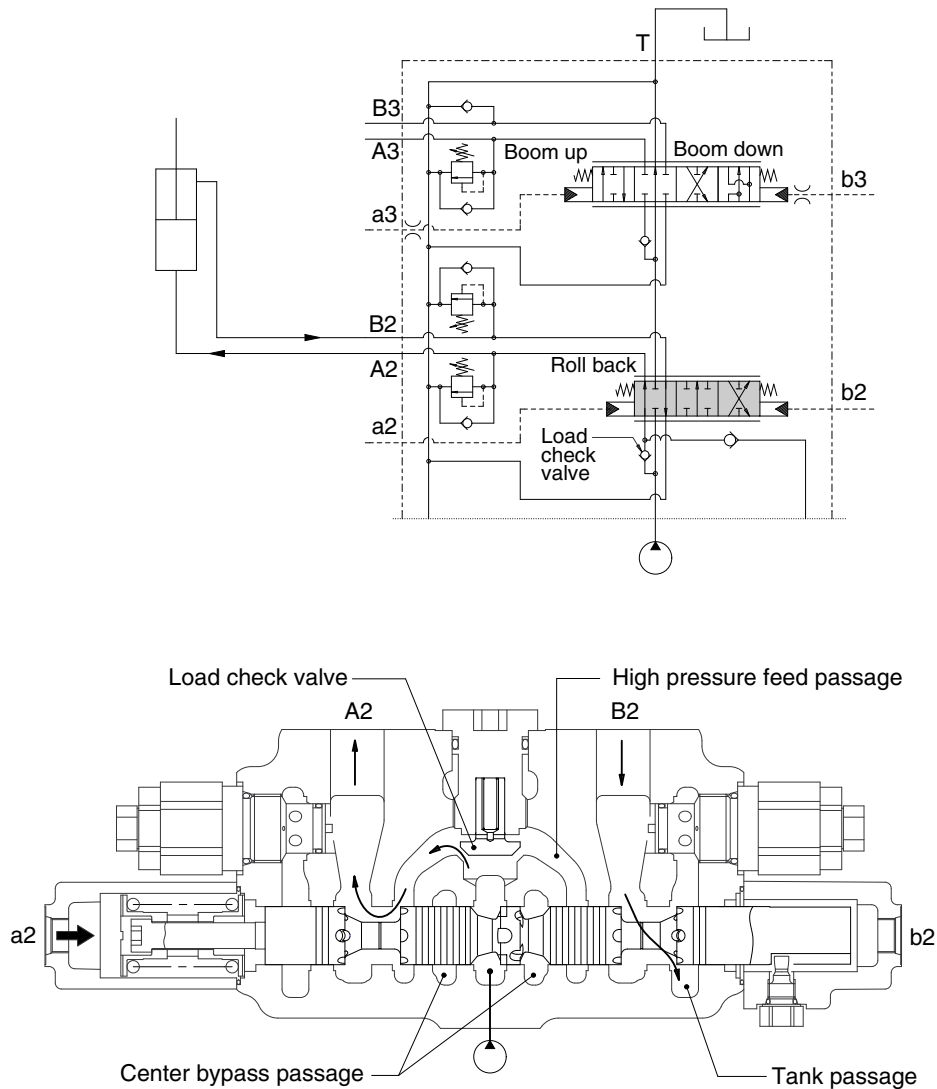

7607WE16

When the pilot pressure is led to the port (a2), the bucket plunger is switched, and shut off center bypass passage.

Oil from the pump flows to the cylinder port (A2) through the load check valve and oil from the cylinder flows into the tank passage through the cylinder port (B2).

※ Load check valve

When the load pressure is higher than the pump pressure, the load check shuts off the passage between the high pressure feed passage and the center bypass passage and prevents the reverse flow from the cylinder.

(3) Bucket dump position

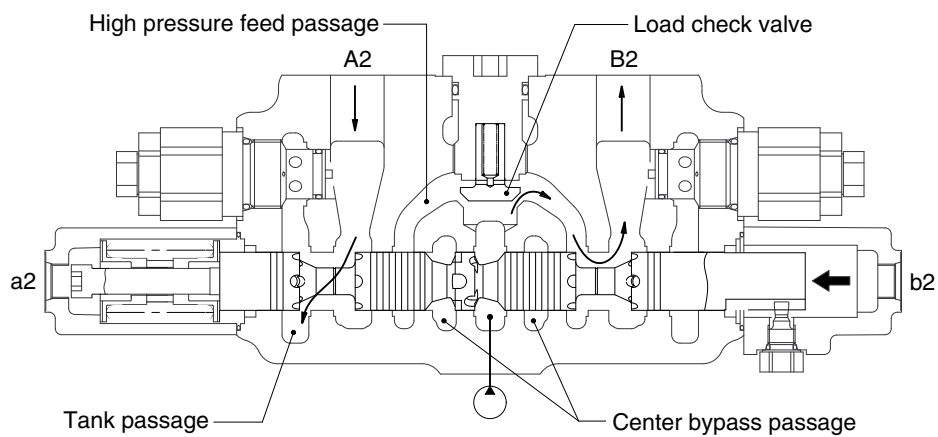
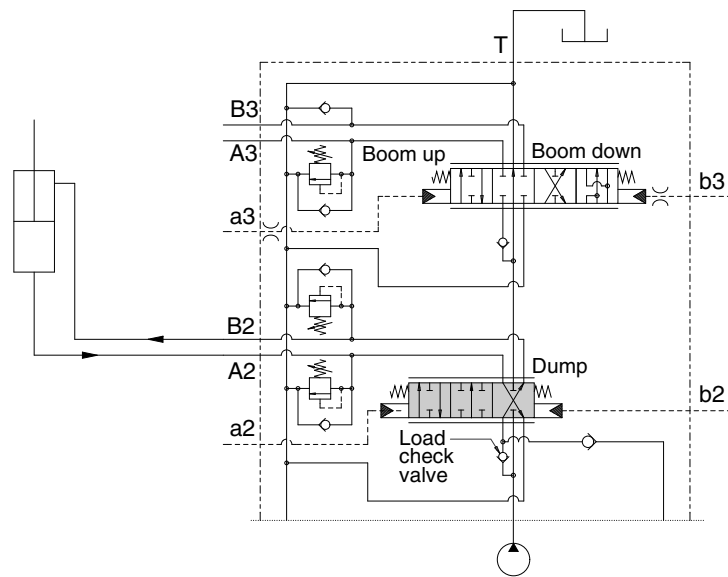

7607WE17

When the pilot pressure is led to the port (b2), the bucket plunger is switched, and shut off center bypass passage.

Oil from the pump flows to the cylinder port (B2) through the load check valve and oil from the cylinder flows into the tank passage through the cylinder port (A2).

4) Main relief valve

- The relief valve is installed between pump circuit and tank circuit in the main control valve housing and keeps system pressure to setting pressure.
- Oil from the pump port (P) enters into the chamber (3) through the orifice (2) of the main poppet (A).
As $d_2 < d_1$, main poppet (A) is securely seated.

- When the pressure reaches the preset force of the spring (C), the pilot poppet (B) opens. Oil flow around pilot poppet (B) and flows into the tank passage (T) through the side hole (4).

- As oil flows from the pump port (P) to the tank passage (T) through the orifice (2) of the main poppet (A), the pressure of the chamber (3) comes to lower than that of the pump port.
Then the main poppet (A) is lifted and pressured oil flows into the tank passage.

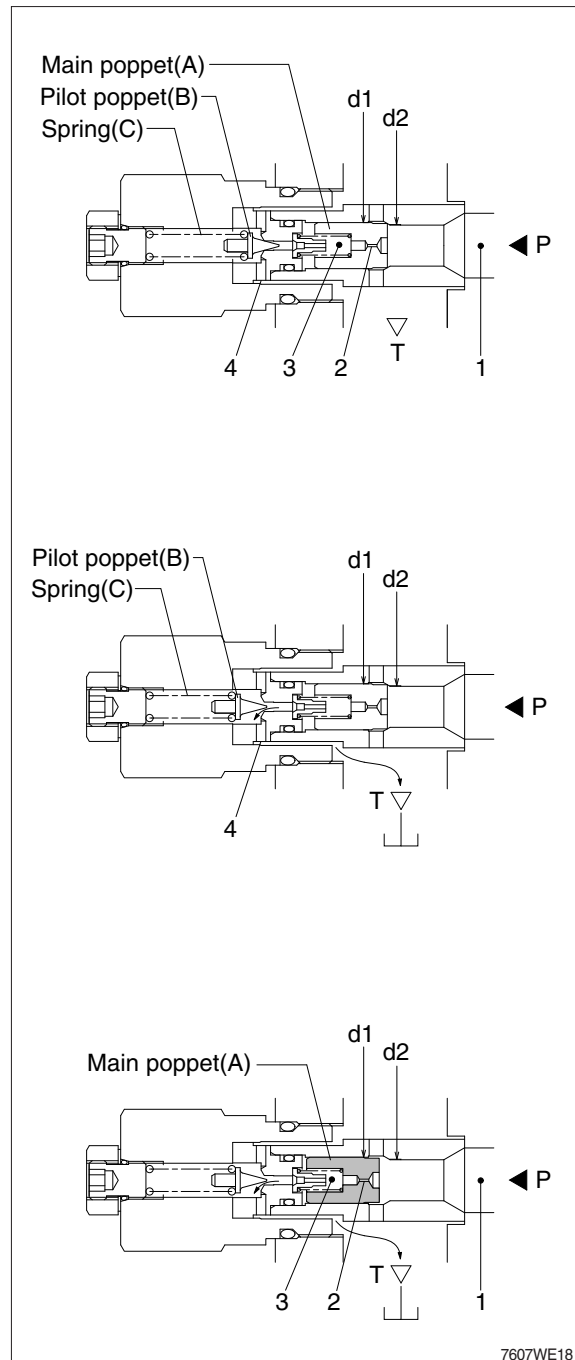

5) Port relief valve

The port relief valve is installed between cylinder port and tank passage.

It protects the actuator from abnormal pressure, due to outer force or sudden block of cylinder pressure.

The port relief valve is the type of built-in make-up function.

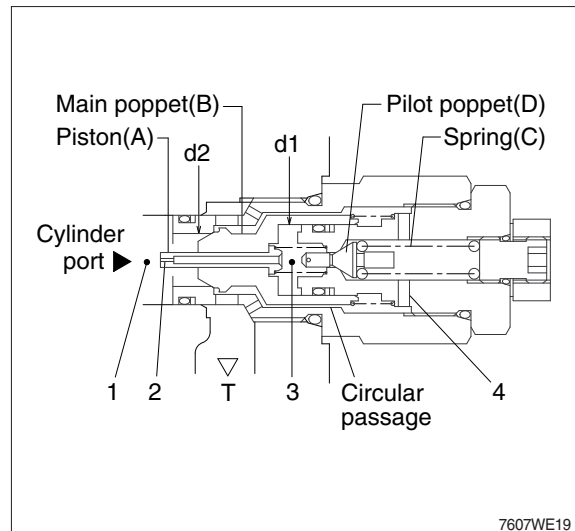

(1) Overload relief function

- ① When the pressure reaches the preset force of the spring (C), the pilot poppet (D) is lifted and pressured oil flows into the tank passage.

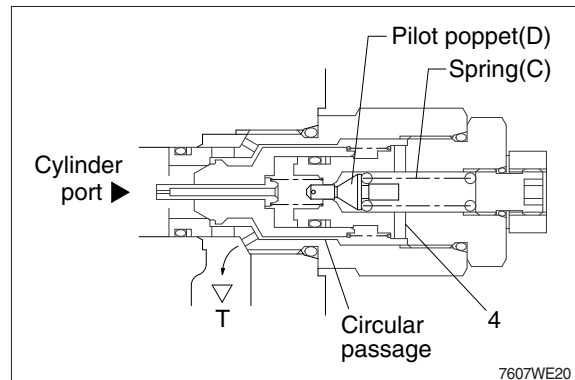

- ② As oil flows from the cylinder port to the tank passage through the orifice (2) of the piston (A), the pressure of the chamber (3) comes to lower than that of the cylinder port. Then the piston (A) is lifted and seated to the pilot poppet (D). Oil from the cylinder port flows to the tank passage through the orifice (5) of the pilot poppet (D), side hole (4) and the circular passage.

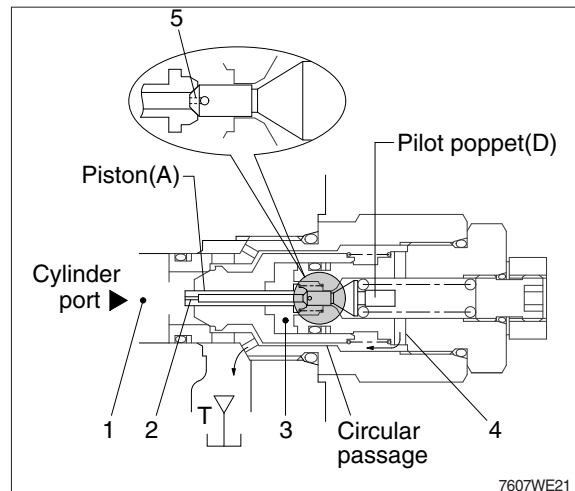

7. PILOT OIL SUPPLY UNIT

1) STRUCTURE

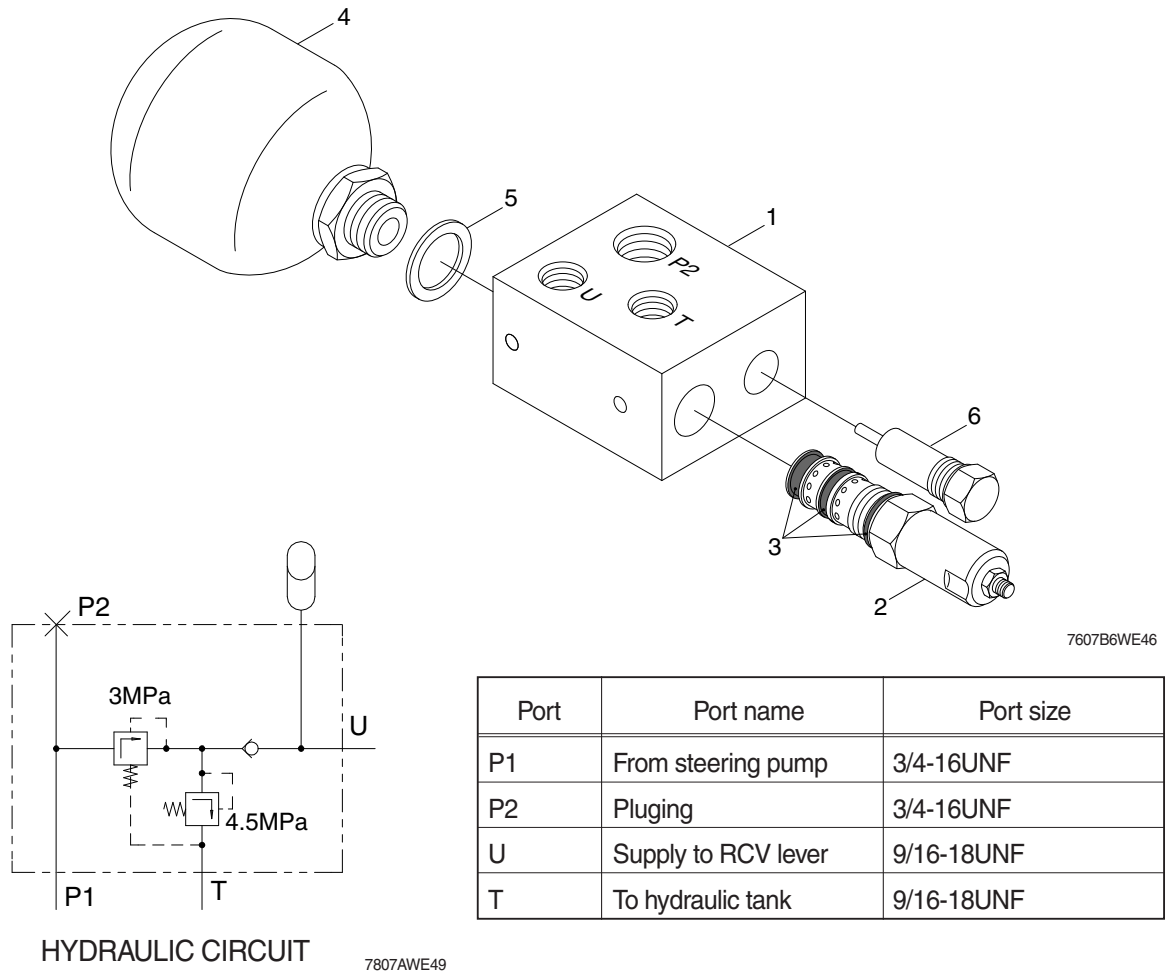

- | | | | |
|---|-------------------|---|--------------|
| 1 | Manifold complete | 4 | Accumulator |
| 2 | Reducing valve | 5 | Gasket |
| 3 | Seal kit | 6 | Relife valve |

(2) OPERATION

The pilot supply manifold reduces the pressure from the high pressure circuit to a low pressure circuit in order to supply the remote control valve.

The accumulator satisfies short term peak power demands and is a source of emergency power in case of main circuit pressure failures.

The unit consists of the housing, the accumulator(4), the relief valve (6), the check valve and the reducing valve (2).

The flow path is from the high pressure circuit through port P2 to the pressure reducing valve (2). The pressure is reduced in the reducing valve (2) and oil passes the check valve into the accumulator (4) and to the port U, which is connected with the remote control valve.

The pressure relief valve (6) protects the pilot circuit in case of the reducing valve (2) failures or external increase of pressure.

8. BOOM AND BUCKET CYLINDER

The boom cylinders are two unit and the bucket cylinder is one unit. They use a bolt on rod guide.

The piston (12) threads on to the rod (2) and is retained by a nut (18) and set screw (19).

The piston seals against the tube (1) with piston seal (15). Two wear rings (16) are located on each side of the piston seal.

The gland (3, the rod guide) seals against the tube with an O-ring (10). The cylinder thread seals against the rod with a lip type buffer ring (7) and a rod seal (5). A dust wiper (8) cleans the rod when it is retracted.

1) BOOM CYLINDER

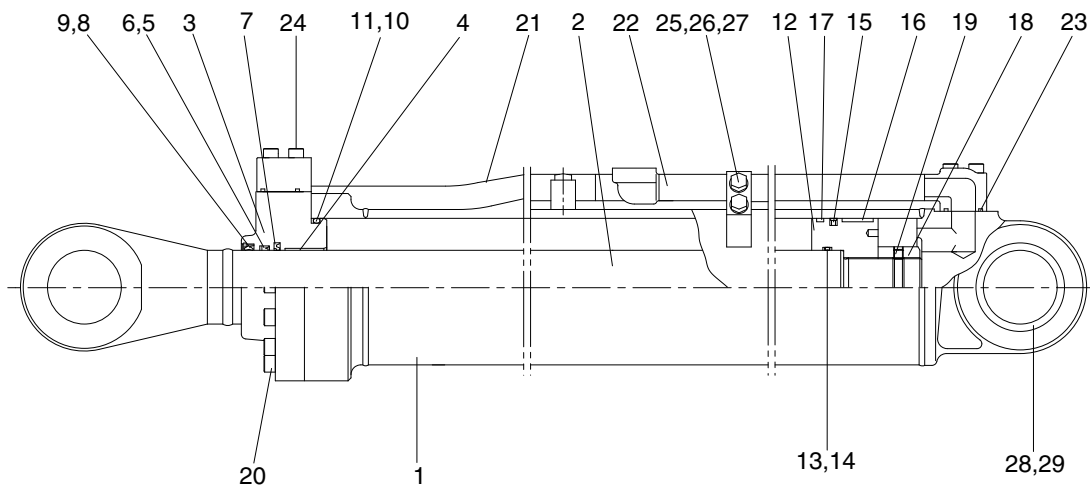

7579S6WE26

1	Tube assembly	11	Back up ring	21	Pipe assembly
2	Rod assembly	12	Piston	22	Pipe assembly
3	Gland	13	O-ring	23	O-ring
4	Bushing	14	Back up ring	24	Bolt
5	Rod seal	15	Piston seal	25	Spring washer
6	Back up ring	16	Wear ring	26	Bolt
7	Buffer ring	17	Dust ring	27	Pipe clamp
8	Dust wiper	18	Lock nut	28	Bushing
9	Snap ring	19	Set screw	29	Dust seal
10	O-ring	20	Bolt		

2) BUCKET CYLINDER

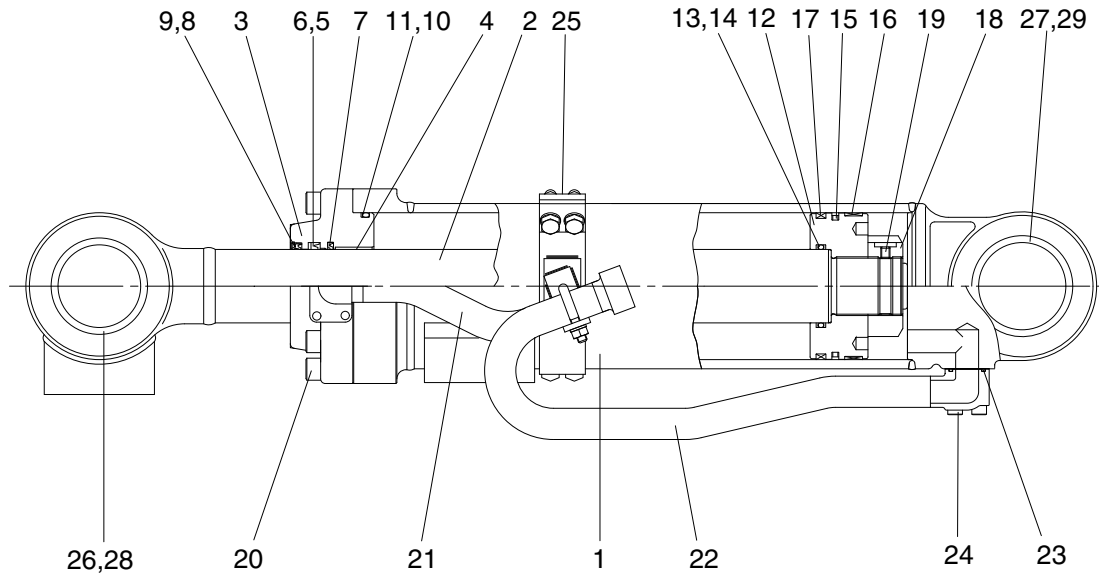

7577S6WE20

- | | | | | | |
|----|---------------|----|--------------|----|---------------|
| 1 | Tube assembly | 11 | Back up ring | 21 | Pipe assembly |
| 2 | Rod assembly | 12 | Piston | 22 | Pipe assembly |
| 3 | Gland | 13 | O-ring | 23 | O-ring |
| 4 | Bushing | 14 | Back up ring | 24 | Bolt |
| 5 | Rod seal | 15 | Piston seal | 25 | Band assembly |
| 6 | Back up ring | 16 | Wear ring | 26 | Pin bushing |
| 7 | Buffer ring | 17 | Dust ring | 27 | Pin bushing |
| 8 | Dust wiper | 18 | Lock nut | 28 | Dust seal |
| 9 | Snap rin | 19 | Set screw | 29 | Dust seal |
| 10 | O-ring | 20 | Bolt | | |

9. HYDRAULIC OIL TANK

1) STRUCTURE

- The oil from the hydraulic tank is sent from the pump through main control valve to the cylinders. In the return circuit, the oil from various parts merges.
- A part of oil is cooled in the oil cooler, passes through the hydraulic filter and returns to the hydraulic tank (1).
- If the hydraulic return oil filter becomes clogged, return filter bypass valve (6) acts to allow the oil to return directly to the hydraulic tank (1). This prevents damage to the hydraulic filter (5). The bypass valve (6) is also actuated when negative pressure is generated in the circuit.

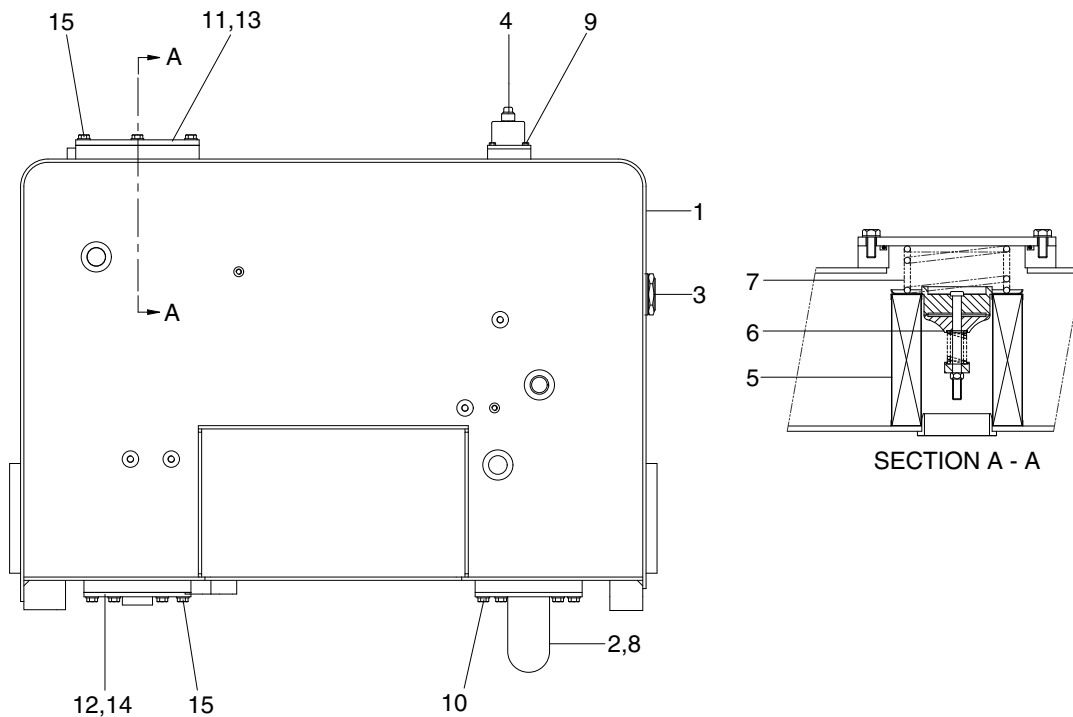

7579SM6WE22

- | | | | |
|---|-------------------|----|-------------|
| 1 | Hydraulic tank wa | 9 | Socket bolt |
| 2 | Pipe wa | 10 | Bolt |
| 3 | Sight gauge | 11 | Cover |
| 4 | Air breather | 12 | Cover |
| 5 | Element assembly | 13 | O-ring |
| 6 | Bypass valve | 14 | O-ring |
| 7 | Spring | 15 | Bolt |
| 8 | O-ring | | |

2) RETURN OIL FILTER BYPASS VALVE

(1) When the filter is clogged

Bypass valve (1) is opened and the oil returns directly to the tank without passing through the filter.

- Bypass valve set pressure : 1.36kgf/cm²
(19.3psi)

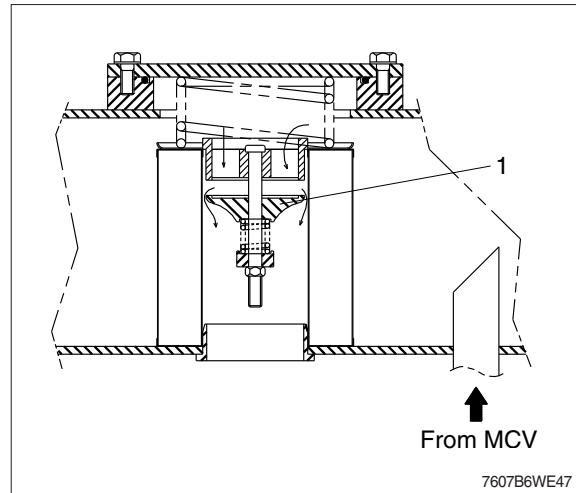

3) AIR BREATHER

The air breather is equipped with the capacity to perform three functions simultaneously-as an air filter, breathing valve, and as a lubrication opening.

(1) Preventing negative pressure inside the tank

The tank is a pressurized sealed type, so negative pressure is formed inside the hydraulic tank when the oil level drops during operations. When this happens, the difference in pressure between the tank and the outside atmospheric pressure opens the poppet in the breather, and air from the outside is let into the tank or prevent negative pressure.

(2) Preventing excessive pressure inside the tank

When the hydraulic cylinder is being used, the oil level in the hydraulic system increases and as temperature rises. If the hydraulic pressure rises above the set pressure, breather is actuated to release the hydraulic pressure inside the tank.

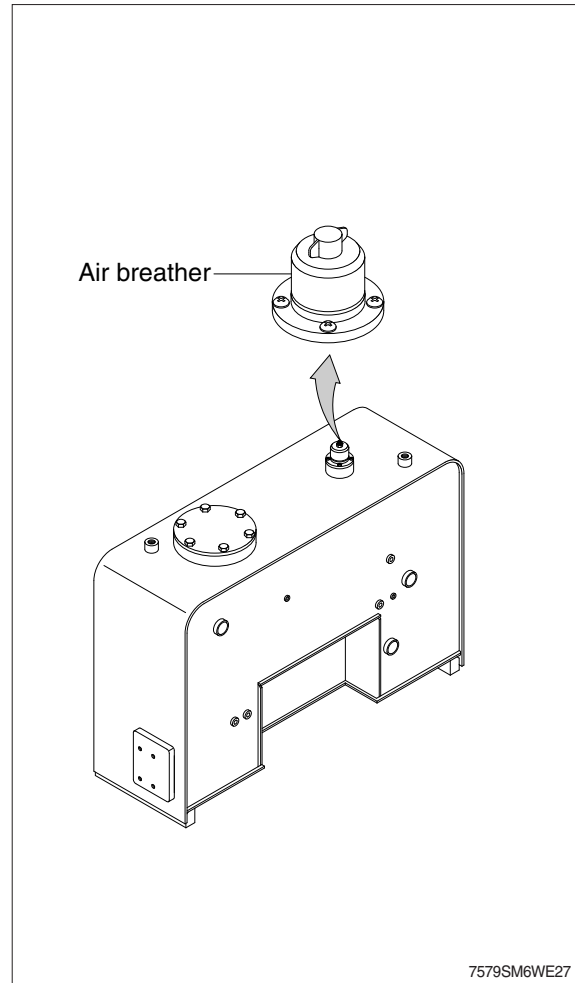

10. ACCUMULATOR

The accumulator is installed at the pilot oil supply unit. When the boom is left the raised position, and the control levers are operated with the engine stopped the pressure of the compressed nitrogen gas inside the accumulator sends pilot pressure to the control valve to actuate it and allow the boom and bucket to come down under their own weight.

Type of gas	Nitrogen gas (N ₂)
Volume of gas	0.75 l (0.2 U.S.gal)
Charging pressure of gas	16 kg/cm ² (228 psi)
Max actuating pressure	128 kg/cm ² (1820 psi)

