

# GROUP 2 SPECIFICATION

## 1. MAJOR COMPONENT

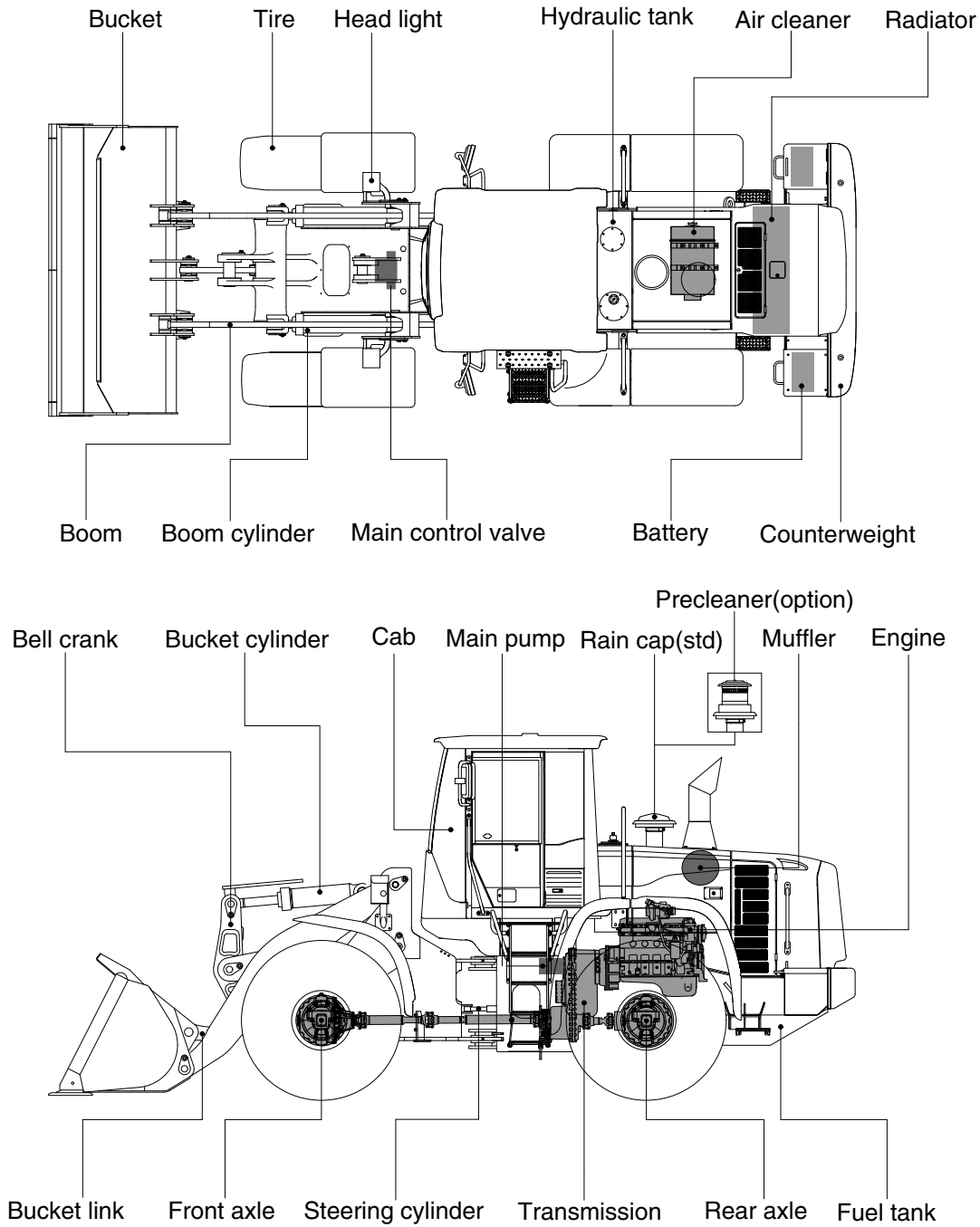

7579SM2SE01

## 2. SPECIFICATIONS

### 1) WITH BOLT-ON CUTTING EDGE TYPE BUCKET (HL757-9SM)

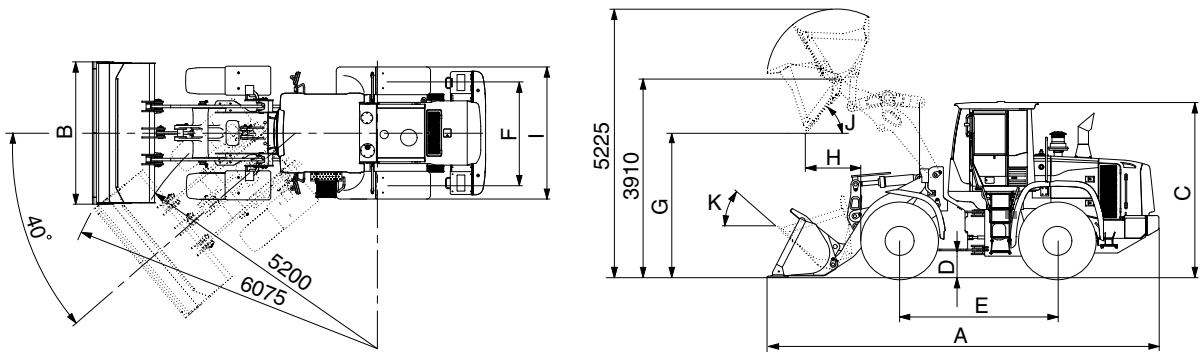

7579SM2SE03

Description		Unit	Specification	
Operating weight		kg (lb)	13600 (30000)	
Bucket capacity	Struck	m <sup>3</sup> (yd <sup>3</sup> )	2.1 (2.8)	
	Heaped		2.5 (3.3)	
Overall length	A	mm (ft-in)	7460 (24' 6")	
Overall width	B		2740 ( 9' 0")	
Overall height	C		3400 (11' 2")	
Ground clearance	D		410 ( 1' 4")	
Wheelbase	E		3050 ( 10' 0")	
Tread	F		2050( 6' 9")	
Dump clearance at 45°	G		2848 ( 9' 4")	
Dump reach (full lift)	H		1000 ( 3' 3")	
Width over tires	I		2580 ( 8' 6")	
Dump angle	J		degree (°)	47
Roll back angle (carry position)	K			46
Cycle time	Lift (with load)	sec	6.1	
	Dump (with load)		1.2	
	Lower (empty)		3.1	
Maximum travel speed		km/hr (mph)	38.0 (23.6)	
Braking distance		m (ft-in)	12 (39' 4")	
Minimum turning radius (center of outside tire)			5.2 (17' 1")	
Gradeability		degree (°)	30	
Brakeout force		kg (lb)	13120 (28920)	
Travel speed	Forward	First gear	7.2 (4.5)	
		Second gear	11.9 (7.4)	
		Third gear	23.8 (14.8)	
		Fourth gear	38.0 (23.6)	
	Reverse	First gear	7.6 (4.7)	
		Second gear	12.6 (7.8)	
Third gear		25.1 (15.6)		

**WITH BOLT-ON CUTTING EDGE TYPE BUCKET (HL757XTD-9SM)**

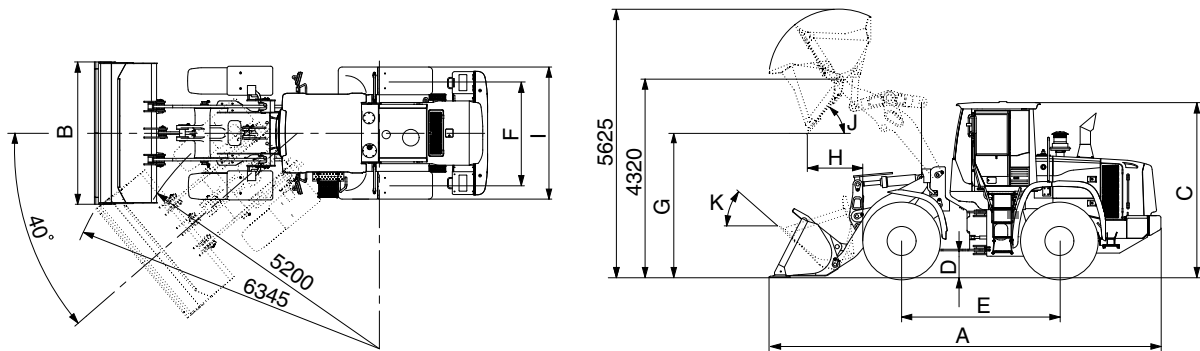

7579SM2SE03-1

Description		Unit	Specification	
Operating weight		kg (lb)	14100 (31080)	
Bucket capacity	Struck	m <sup>3</sup> (yd <sup>3</sup> )	2.1 (2.8)	
	Heaped		2.5 (3.3)	
Overall length	A	mm (ft-in)	7890 (25' 11")	
Overall width	B		2740 ( 9' 0")	
Overall height	C		3400 (11' 2")	
Ground clearance	D		410 ( 1' 4")	
Wheelbase	E		3050 ( 10' 0")	
Tread	F		2050 ( 6' 9")	
Dump clearance at 45°	G		3265 (10' 9")	
Dump reach (full lift)	H		1000 ( 3' 3")	
Width over tires	I		2580 ( 8' 6")	
Dump angle	J		degree (°)	47
Roll back angle (carry position)	K			48
Cycle time	Lift (with load)	sec	6.1	
	Dump (with load)		1.2	
	Lower (empty)		3.1	
Maximum travel speed		km/hr (mph)	38.0 (23.6)	
Braking distance		m (ft-in)	12 (39' 4")	
Minimum turning radius (center of outside tire)			5.2 (17' 1")	
Gradeability		degree (°)	30	
Brakeout force		kg (lb)	12950 (28550)	
Travel speed	Forward	First gear	7.2 (4.5)	
		Second gear	11.9 (7.4)	
		Third gear	23.8 (14.8)	
		Fourth gear	38.0 (23.6)	
	Reverse	First gear	7.6 (4.7)	
		Second gear	12.6 (7.8)	
Third gear		25.1 (15.6)		

**2) WITH TOOTH TYPE BUCKET (HL757-9SM)**

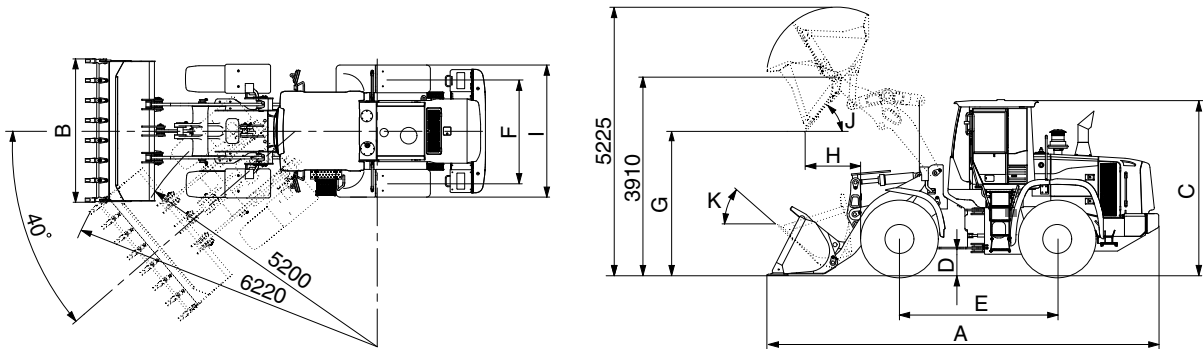

7579SM2SE02

Description		Unit	Specification	
Operating weight		kg (lb)	13600 (30000)	
Bucket capacity	Struck	m <sup>3</sup> (yd <sup>3</sup> )	2.0 (2.6)	
	Heaped		2.4 (3.1)	
Overall length	A	mm (ft-in)	7560 (24' 10")	
Overall width	B		2790 ( 9' 2")	
Overall height	C		3400 (11' 2")	
Ground clearance	D		410 ( 1' 4")	
Wheelbase	E		3050 ( 10' 0")	
Tread	F		2050 ( 6' 9")	
Dump clearance at 45°	G		2760 ( 9' 1")	
Dump reach (full lift)	H		1075 ( 3' 6")	
Width over tires	I		2580 ( 8' 6")	
Dump angle	J		degree (°)	47
Roll back angle (carry position)	K			46
Cycle time	Lift (with load)	sec	6.1	
	Dump (with load)		1.2	
	Lower (empty)		3.1	
Maximum travel speed		km/hr (mph)	38.0 (23.6)	
Braking distance		m (ft-in)	12 (39' 4")	
Minimum turning radius (center of outside tire)			5.2 (17' 1")	
Gradeability		degree (°)	30	
Brakeout force		kg (lb)	11810 (26040)	
Travel speed	Forward	First gear	7.2 (4.5)	
		Second gear	11.9 (7.4)	
		Third gear	23.8 (14.8)	
		Fourth gear	38.0 (23.6)	
	Reverse	First gear	7.6 (4.7)	
		Second gear	12.6 (7.8)	
Third gear		25.1 (15.6)		

## WITH TOOTH TYPE BUCKET (HL757XTD-9SM)

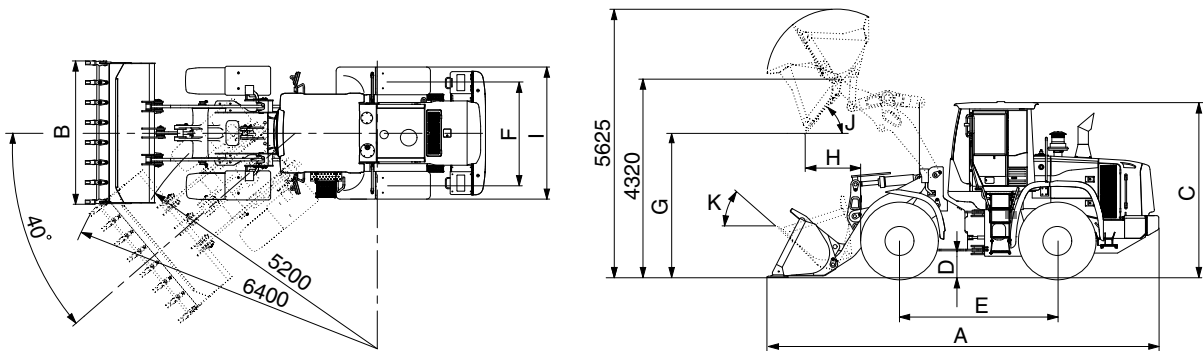

7579SM2SE02-1

Description		Unit	Specification	
Operating weight		kg (lb)	14100 (31080)	
Bucket capacity	Struck	m <sup>3</sup> (yd <sup>3</sup> )	2.0 (2.6)	
	Heaped		2.4 (3.1)	
Overall length	A	mm (ft-in)	7990 (26' 3")	
Overall width	B		2790 ( 9' 2")	
Overall height	C		3400 (11' 2")	
Ground clearance	D		410 ( 1' 4")	
Wheelbase	E		3050 ( 10' 0")	
Tread	F		2050 ( 6' 9")	
Dump clearance at 45°	G		3175 ( 10' 5")	
Dump reach (full lift)	H		1075 ( 3' 6")	
Width over tires	I		2580 ( 8' 6")	
Dump angle	J		degree (°)	47
Roll back angle (carry position)	K			48
Cycle time	Lift (with load)	sec	6.1	
	Dump (with load)		1.2	
	Lower (empty)		3.1	
Maximum travel speed		km/hr (mph)	38.0 (23.6)	
Braking distance		m (ft-in)	12 (39' 4")	
Minimum turning radius (center of outside tire)			5.2 (17' 1")	
Gradeability		degree (°)	30	
Brakeout force		kg (lb)	11440 (25220)	
Travel speed	Forward	First gear	7.2 (4.5)	
		Second gear	11.9 (7.4)	
		Third gear	23.8 (14.8)	
	Reverse	First gear	7.6 (4.7)	
		Second gear	12.6 (7.8)	
		Third gear	25.1 (15.6)	

### 3. WEIGHT

Item		kg	lb
Front frame assembly		1139	2510
Rear frame assembly		1422	3130
Front fender (LH & RH)		31	68
Counterweight	HL757-9SM	550	1210
	HL757XTD-9SM	840	1850
Cab assembly		780	1720
Engine assembly		432	952
Transmission assembly		518	1140
Drive shaft (front)		26	57
Drive shaft (center)		22	49
Drive shaft (rear)		13	29
Front axle (include differential)		970	2140
Rear axle (include differential)		760	1680
Tire (20.5-25, 16PR, L3)		203	448
Hydraulic tank assembly		160	353
Fuel tank assembly		219	483
Main pump assembly		40	88
Fan & brake pump assembly		6.5	14.3
Main control valve (2/3 spool)		45 / 65	99 / 143
Steering valve (EHPS)		10	22
Boom assembly	HL757-9SM	980	2160
	HL757XTD-9SM	1145	2520
Bell crank assembly		264	580
Bucket link		48	110
2.5 m <sup>3</sup> bucket, with bolt on cutting edge		1060	2340
2.4 m <sup>3</sup> bucket, with tooth		1045	2300
Boom cylinder assembly		108	238
Bucket cylinder assembly		122	269
Steering cylinder assembly		29	64
Seat		40	88
Battery		44	97

#### 4. SPECIFICATION FOR MAJOR COMPONENTS

##### 1) ENGINE

Item	Specification
Model	Cummins 6BTAA5.9
Type	4-cycle turbocharged and charge air-cooled diesel engine
Control type	Mechanical control
Cooling method	Water cooling
Number of cylinders and arrangement	6 cylinders, in-line
Firing order	1-5-3-6-2-4
Combustion chamber type	Direct injection type
Cylinder bore × stroke	102 × 120 mm (4.0" × 4.7")
Piston displacement	5900 cc (359 cu in)
Compression ratio	18.0 : 1
Rated horse power (Net)	173 hp at 2200 rpm
Maximum torque at 1400 rpm (Net)	80 kgf · m (579 lbf · ft)
Engine oil quantity	15 l (4.0 U.S. gal)
Wet weight	432 kg (952 lb)
High idling speed	2400 ± 50 rpm
Low idling speed	800 ± 25 rpm
Rated fuel consumption	225 g/kW · hr
Starting motor	Denso PA908 (24V-4.8kW)
Alternator	Delco Remy 24SI (24V-70Amp)
Battery	2 × 12V × 160Ah

## 2) MAIN PUMP

Item	Specification
Type	Gear pump
Capacity	51+51 cc/rev
Maximum operating pressure	210 kgf/cm <sup>2</sup> (2990 psi)
Rated oil quantity	220 l /min (58.1 U.S.gpm)
High speed	2400 rpm

## 3) FAN + BRAKE PUMP

Item	Specification	
	Fan	Brake
Type	Gear pump	
Capacity	19.4 cc/rev	11.9 cc/rev
Maximum operating pressure	120 kgf/cm <sup>2</sup> (1710 psi)	150 kgf/cm <sup>2</sup> (2130 psi)
Rated oil quantity	42 l /min (11.1 U.S.gpm)	26 l /min (6.9 U.S.gpm)
High speed	2400 rpm	

## 4) MAIN CONTROL VALVE

Item	Specification
Type	2 spool
Operating method	Hydraulic pilot assist
System pressure	200 kgf/cm <sup>2</sup> (2840 psi)
Overload relief valve pressure	240 kgf/cm <sup>2</sup> (3410 psi)

## 5) REMOTE CONTROL VALVE

Item	Specification	
Type	Pressure reducing type	
Operating pressure	Minimum	6.5 kgf/cm <sup>2</sup> (92.4 psi)
	Maximum	22 kgf/cm <sup>2</sup> (312.9 psi)
Single operation stroke	Lever	80 mm (3.4 in)



## 6) CYLINDER

Item		Specification
Boom cylinder	Bore dia × Rod dia × Stroke	∅ 140 × ∅ 75 × 750 mm
Bucket cylinder	Bore dia × Rod dia × Stroke	∅ 160 × ∅ 80 × 475 mm
Steering cylinder	Bore dia × Rod dia × Stroke	∅ 70 × ∅ 45 × 436 mm

## 7) DYNAMIC POWER TRANSMISSION DEVICES

Item		Specification	
Transmission	Model	4WG190	
	Type	Converter	Single-stage, single-phase
		Transmission	Full-automatic power shift
	Converter stall ratio	2.542 : 1	
	Gear shift	Forward fourth gear, reverse third gear	
	Control	Electrical single lever type, kick-down system	
	Pump rated flow	105 ℓ /min (27.7 U.S.gpm) at 2000 rpm	
Axle	Drive devices	4-wheel drive	
	Front	Front fixed location	
	Rear	Oscillation ± 13° of center pin-loaded	
Wheels	Tires	20.5-25, 16PR (L3)	
Brakes	Travel	Four-wheel, wet-disc type, full hydraulic	
	Parking	Spring applied, hydraulic released brake on transmission	
Steering	Type	Full hydraulic, articulated	
	Steering angle	40° to both right and left angle, respectively	

## 5. TIGHTENING TORQUE OF MAJOR COMPONENT

No.	Descriptions	Bolt size	Torque		
			kgf · m	lbf · ft	
1	Engine	Engine mounting bolt, nut (rubber, 2EA)	M20 × 2.5	46.3 ± 7.0	335 ± 50.6
2		Engine mounting bolt (bracket, 8EA)	M12 × 1.75	10.7 ± 1.6	77.4 ± 11.6
3		Engine mounting bolt (T/C housing, 12EA)	M10 × 1.5	4.6 ± 0.9	33.3 ± 6.5
4		Engine mounting bolt (flywheel, 4EA)	M10 × 1.5	4.5 ± 0.6	32.5 ± 4.3
5		Radiator mounting bolt	M16 × 2.0	29.7 ± 4.5	215 ± 32.5
6		Fuel tank mounting bolt	M16 × 2.0	29.7 ± 4.5	215 ± 32.5
7	Hydraulic system	Main pump housing mounting bolt	M12 × 1.75	12.8 ± 3.0	92.6 ± 21.7
8		Fan & Brake pump housing mounting bolt	M10 × 1.5	6.9 ± 1.4	50 ± 10.1
9		Main control valve mounting bolt	M12 × 1.75	12.8 ± 3.0	92.6 ± 21.7
10		Steering unit mounting bolt	M10 × 1.5	6.9 ± 1.4	50 ± 10.1
11		Stop valve	M10 × 1.5	6.9 ± 1.4	50 ± 10.1
12		Steering valve (EHPS) mounting bolt	M8 × 1.25	2.5 ± 0.5	18.1 ± 3.6
13		Cushion valve	M8 × 1.25	2.5 ± 0.5	18.1 ± 3.6
14		Brake valve mounting bolt	M8 × 1.25	2.5 ± 0.5	18.1 ± 3.6
15		Cut-off valve mounting bolt	M12 × 1.75	12.8 ± 3.0	92.6 ± 21.7
16		Remote control lever mounting bolt	M6 × 1.0	1.1 ± 0.2	8.0 ± 1.4
17		Safety valve	M8 × 1.25	2.5 ± 0.5	18.1 ± 3.6
18		Hydraulic oil tank mounting bolt	M16 × 2.0	29.7 ± 4.5	215 ± 32.5
19	Power train system	Transmission mounting bolt, nut (rubber, 2EA)	M24 × 3.0	100 ± 15	723 ± 108
20		Transmission mounting bolt (bracket, 6EA)	M20 × 2.5	46.3 ± 7.0	335 ± 50.6
21		Front axle mounting bolt, nut	M27 × 2.0	135 ± 15	976 ± 108
22		Rear axle support mounting bolt, nut	M27 × 2.0	135 ± 15	976 ± 108
23		Tire mounting nut	M22 × 1.5	79 ± 2.5	571 ± 18.1
24		Drive shaft joint mounting bolt	1/2-20UNF	6.0 ± 0.8	43.4 ± 5.8
25	Others	Counterweight mounting bolt	M30 × 3.5	199 ± 30	1440 ± 216
26		Operator's seat mounting bolt	M8 × 1.25	3.4 ± 0.8	24.6 ± 5
27		Cab mounting bolt (4EA)	M20 × 2.5	57.9 ± 8.7	419 ± 62.9
28		Cab mounting nut (4EA)	M16 × 2.0	29.7 ± 4.5	215 ± 32.5

## 6. TORQUE CHART

Use following table for unspecified torque.

### 1) BOLT AND NUT

#### (1) Coarse thread

Bolt size	8T		10T	
	kg · m	lb · ft	kg · m	lb · ft
M 6 × 1.0	0.85 ~ 1.25	6.15 ~ 9.04	1.14 ~ 1.74	8.2 ~ 12.6
M 8 × 1.25	2.0 ~ 3.0	14.5 ~ 21.7	2.73 ~ 4.12	19.5 ~ 29.8
M10 × 1.5	4.0 ~ 6.0	28.9 ~ 43.4	5.5 ~ 8.3	39.8 ~ 60
M12 × 1.75	7.4 ~ 11.2	53.5 ~ 79.5	9.8 ~ 15.8	71 ~ 114
M14 × 2.0	12.2 ~ 16.6	88.2 ~ 120	16.7 ~ 22.5	121 ~ 167
M16 × 2.0	18.6 ~ 25.2	135 ~ 182	25.2 ~ 34.2	182 ~ 247
M18 × 2.5	25.8 ~ 35.0	187 ~ 253	35.1 ~ 47.5	254 ~ 343
M20 × 2.5	36.2 ~ 49.0	262 ~ 354	49.2 ~ 66.6	356 ~ 482
M22 × 2.5	48.3 ~ 63.3	350 ~ 457	65.8 ~ 98.0	476 ~ 709
M24 × 3.0	62.5 ~ 84.5	452 ~ 611	85.0 ~ 115	615 ~ 832
M30 × 3.0	124 ~ 168	898 ~ 1214	169 ~ 229	1223 ~ 1655
M36 × 4.0	174 ~ 236	1261 ~ 1703	250 ~ 310	1808 ~ 2242

#### (2) Fine thread

Bolt size	8T		10T	
	kg · m	lb · ft	kg · m	lb · ft
M 8 × 1.0	2.17 ~ 3.37	15.7 ~ 24.3	3.04 ~ 4.44	22.0 ~ 32.0
M10 × 1.25	4.46 ~ 6.66	32.3 ~ 48.2	5.93 ~ 8.93	42.9 ~ 64.6
M12 × 1.25	7.78 ~ 11.58	76.3 ~ 83.7	10.6 ~ 16.0	76.6 ~ 115
M14 × 1.5	13.3 ~ 18.1	96.2 ~ 130	17.9 ~ 24.1	130 ~ 174
M16 × 1.5	19.9 ~ 26.9	144 ~ 194	26.6 ~ 36.0	193 ~ 260
M18 × 1.5	28.6 ~ 43.6	207 ~ 315	38.4 ~ 52.0	278 ~ 376
M20 × 1.5	40.0 ~ 54.0	289 ~ 390	53.4 ~ 72.2	386 ~ 522
M22 × 1.5	52.7 ~ 71.3	381 ~ 515	70.7 ~ 95.7	512 ~ 692
M24 × 2.0	67.9 ~ 91.9	491 ~ 664	90.9 ~ 123	658 ~ 890
M30 × 2.0	137 ~ 185	990 ~ 1338	182 ~ 248	1314 ~ 1795
M36 × 3.0	192 ~ 260	1389 ~ 1879	262 ~ 354	1893 ~ 2561

**2) PIPE AND HOSE (FLARE type)**

Thread size	Width across flat (mm)	kgf · m	lbf · ft
1/4"	19	4	28.9
3/8"	22	5	36.2
1/2"	27	9.5	68.7
3/4"	36	18	130
1"	41	21	152
1-1/4"	50	35	253

**3) PIPE AND HOSE (ORFS type)**

Thread size	Width across flat (mm)	kgf · m	lbf · ft
9/16-18	19	4	28.9
11/16-16	22	5	36.2
13/16-16	27	9.5	68.7
1-3/16-12	36	18	130
1-7/16-12	41	21	152
1-11/16-12	50	35	253

**4) FITTING**

Thread size	Width across flat (mm)	kgf · m	lbf · ft
1/4"	19	4	28.9
3/8"	22	5	36.2
1/2"	27	9.5	68.7
3/4"	36	18	130
1"	41	21	152
1-1/4"	50	35	253

## 7. RECOMMENDED LUBRICANTS

Use only oils listed below or equivalent.

Do not mix different brand oil.

Service point	Kind of fluid	Capacity ℓ (U.S. gal)	Ambient temperature °C ( °F)						
			-50 (-58)	-30 (-22)	-20 (-4)	-10 (14)	0 (32)	10 (50)	20 (68)
Engine oil pan	Engine oil	15 (4.0)	* <sup>1</sup> SAE 5W-40						
			SAE 30						
			SAE 10W						
			SAE 10W-30						
			SAE 15W-40						
Transmission	Engine oil	28 (7.4)	SAE 10W-30						
			SAE 15W-40						
Axle	UTTO	FR : 32 (8.5) RR : 24 (6.3)	* Refer to below list						
Hydraulic tank	Hydraulic oil	Tank; 110 (29.1) System; 242 (63.9)	* <sup>1</sup> ISO VG 15						
			ISO VG 46						
			ISO VG 68						
Fuel tank	Diesel fuel	230 (60.8)	* <sup>1</sup> ASTM D975 NO.1						
			ASTM D975 NO.2						
Fitting (grease nipple)	Grease	As required	* <sup>1</sup> NLGI NO.1						
			NLGI NO.2						
Radiator (reservoir tank)	Mixture of antifreeze and soft water* <sup>2</sup>	30 (7.9)	Ethylene glycol base permanent type (50 : 50)						
			* <sup>1</sup> Ethylene glycol base permanent type (60 : 40)						

**SAE** : Society of Automotive Engineers

**API** : American Petroleum Institute

**ISO** : International Organization for Standardization

**NLGI** : National Lubricating Grease Institute

**ASTM** : American Society of Testing and Material

**UTTO** : Universal Tractor Transmission Oil

\* Recommended oil list

- BP TERRAC SUPER TRANSMISSION 10W-30

- CASTROL AGRI TRANS PLUS 10W-30

- MOBILFLUID 426

- SHELL DONAX TD 10W-30

- TOTAL DYNATRANS MPV

\*<sup>1</sup> Cold region

Russia, CIS, Mongolia

\*<sup>2</sup> Soft water

City water or distilled water