

GROUP 4 DISASSEMBLY AND ASSEMBLY

1. MAIN PUMP

1) STRUCTURE

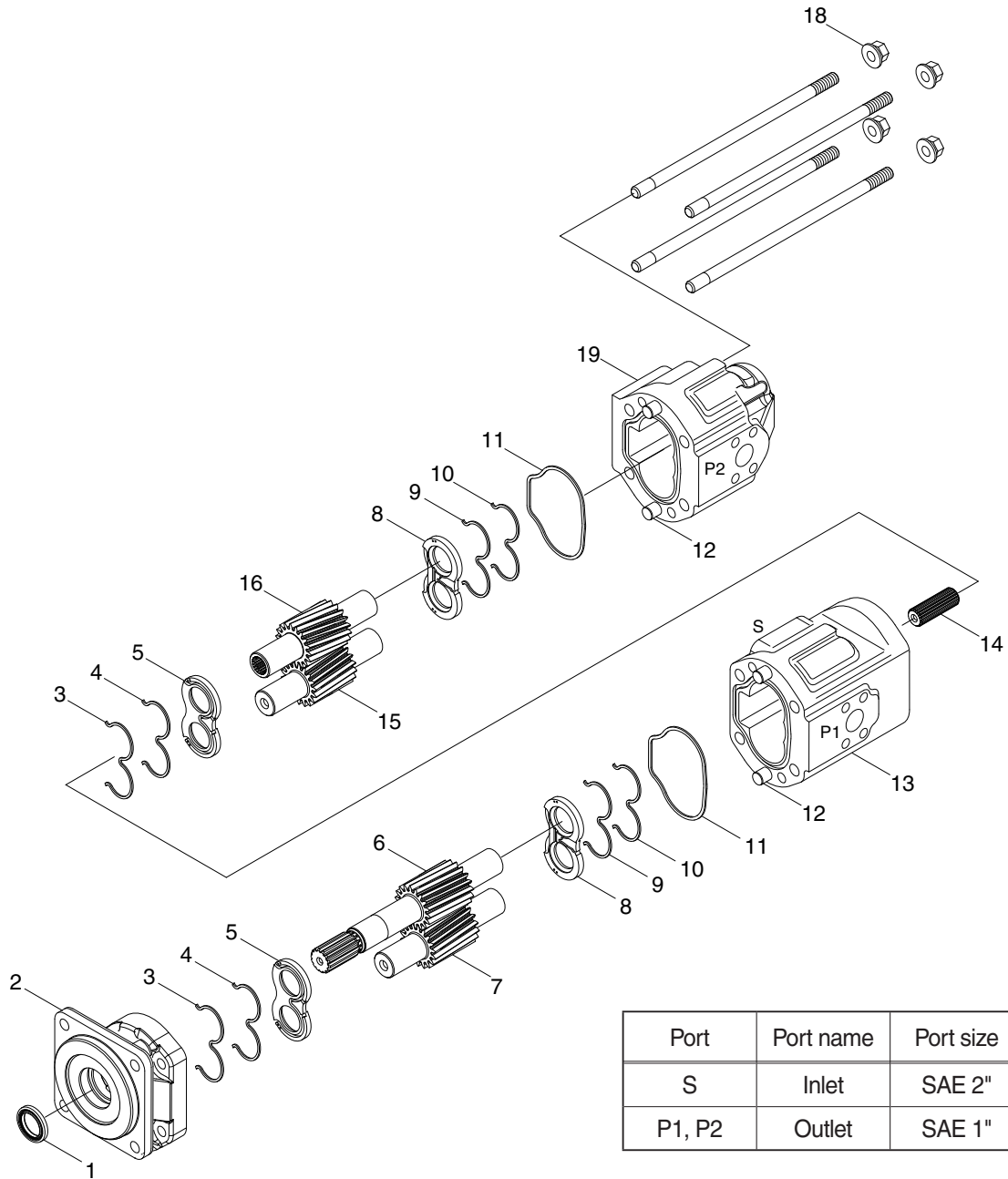

Port	Port name	Port size
S	Inlet	SAE 2"
P1, P2	Outlet	SAE 1"

7579SM6WE29

- | | | | | | |
|---|-------------------|----|-----------------|----|------------------|
| 1 | Shaft seal | 8 | Wearplate | 15 | Rear driven gear |
| 2 | Adapter | 9 | O-ring seal | 16 | Rear drive gear |
| 3 | Back up seal | 10 | Back up seal | 17 | Stud |
| 4 | O-ring seal | 11 | Interface seal | 18 | Flanged nut |
| 5 | Wearplate | 12 | Dowel | 19 | Rear body |
| 6 | Front drive gear | 13 | Front body | | |
| 7 | Front driven gear | 14 | Spline coupling | | |

2) DISASSEMBLY

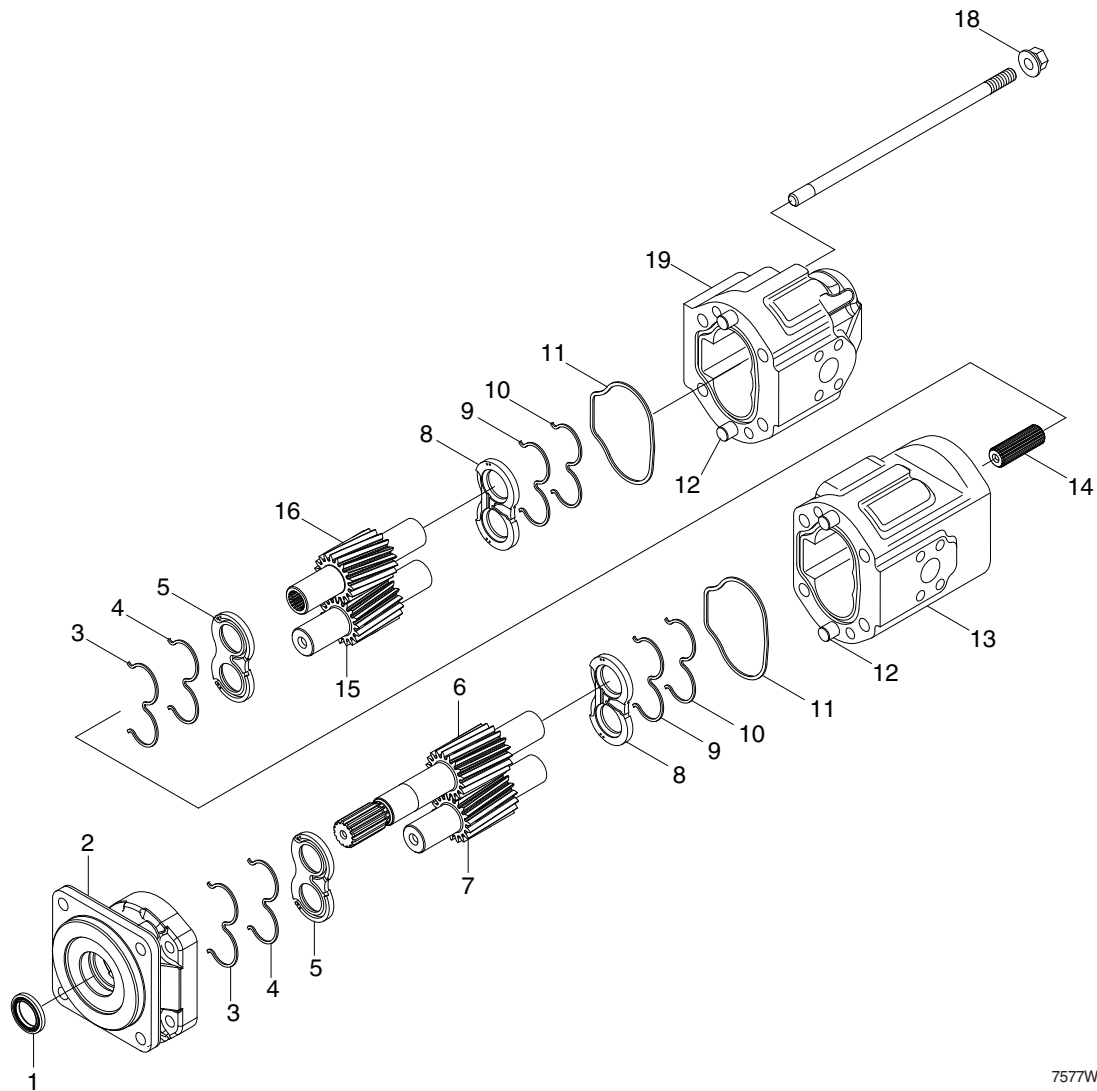

7577WE33

- ※ Plug all ports prior to cleaning and disassembling pump to prevent ingress of debris or contamination.
 - ※ Clean the pump thoroughly with a solvent, ensuring no loose debris or contamination remains on the unit.
 - ※ Mark each interface and then separate into individual pump sections.
- (1) Securely clamp pump horizontally on one port face, ensuring that no damage is sustained to the port face and remove the stud (17) and nut (18).
 - (2) Remove the front adapter (2) from the body (13) using a pulling tool centred on the drive shaft (6).
- ※ Under **NO** circumstances attempt to prise or chisel cover from body as such action could damage the machined sealing faces.
- (3) Remove and discard the shaft seal (1) from adaptor making sure that no damage is sustained to the surface of the seal bore.
 - (4) Unclamp pump and place it vertically with drive shaft up.
 - (5) Before removing wearplate from the body mark it using a soft pencil or a felt-tip pen to ensure correct reassembly. Remove wearplate (5) complete with O-ring seal (4) and back up seal (3).

DISASSEMBLY

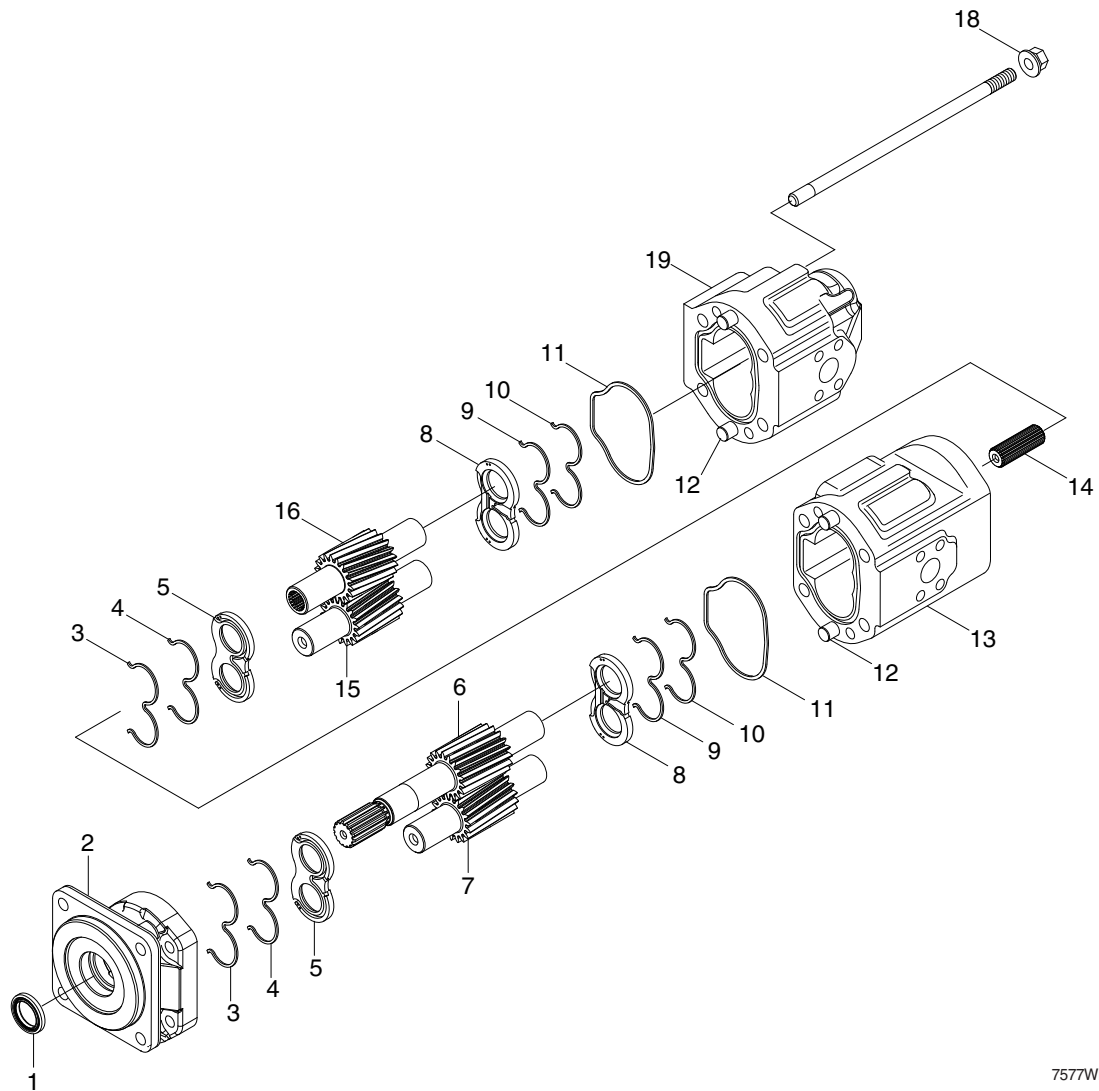

7577WE33

- (6) Mark the gears using a soft pencil or felt-tip pen to ensure assembly in the same relative position, see figure on the right, then withdraw the drive shaft/gear (6) and driven gear (7) separately to prevent jamming.
- (7) Again, to ensure correct assembly, mark remaining wearplate (8) using a soft pencil or a felt-tip pen. Remove wearplate from body complete with O-ring seal (9) and back up seal (10).
- (8) Discard interface seal (11).
- (9) Having separated into individual pumps, proceed as per paragraph (1)~(4).



7607WE34

3) MANDATORY REPLACEMENT PARTS

Discard all seals including interface seals, shaft seals, wear plate seals and back up seals. Fit new seals on reassembly. Wearplates should also be replaced with new items from seal kit.

4) HANDLING/STORAGE

While disassembling pump, ensure no surfaces are scored or marked in any way. A rubber surfaced table will be beneficial. All components must be placed in a clean, dry and safe area.

Leakage will be created by scratches on components. If parts are to be left for any period ensure they are not exposed to dirt, dust and corrosion. Keep gears separate from each other in protective boxes.

5) INSPECTION OF PARTS

Wash all parts in a solvent and dry.

(1) Adaptor housing and cover

The pump must be replaced if the damage listed is present.

Feature	Damage
Surfaces	Corrosion, nicks or burrs (slight burrs can be removed using and india stone)
Machined sealing Interfaces	Scores, cracks or corrosion
Bearing	Loose

(2) Gears

The pump must be replaced if the damage listed is present.

Feature	Damage
Surfaces	Corrosion, nicks or burrs (slight burrs can be removed using an India stone). Wear due to seal (s)
Journals	Pitting, wear, sufficient wear to change outside diameter
Tooth	Cracks or heavy scoring or chipped
Splines/keyways	Distortion of wear
End faces	Wear, cracks

(3) Floating wear plates

The pump must be replaced if the damage listed is present.

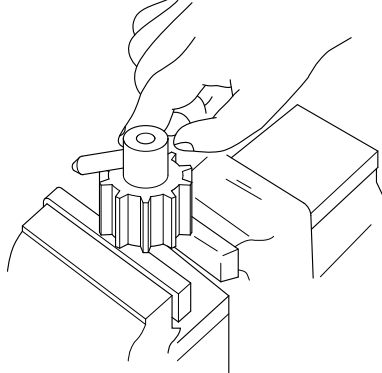
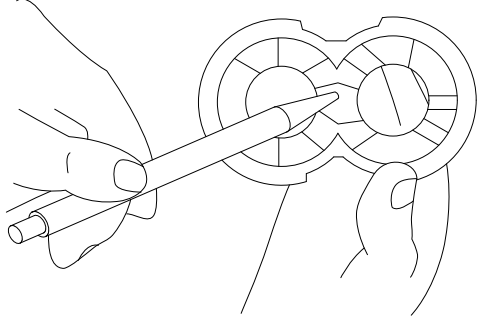
Feature	Damage
Surfaces	Corrosion, nicks or burrs, amounts of scoring, erosion or any cracks, discoloration caused by overheating
	
Removing burrs or minor scoring from end faces and teeth of the gears.	Scoring of wear plate.

(4) Bolts/Studs

The pump should be replaced if the damage listed is present.

Feature	Damage
Surfaces	Corrosion, nicks or burrs (slight burrs can be removed using an India stone), cracks or scoring, distortion or damage to thread form

(5) Plain bearings

The pump must be replaced if the damage listed is present.

Feature	Damage
Surfaces	Cracks or scoring
PTEF Coating	Worn-bronze, sub-layer showing
Bearing	Loose in housing/cover

(6) Coupling

This must be replaced if damage listed is present.

Feature	Damage
Surfaces	Corrosion, nicks or burrs, erosion, cracks or pitting
Splines	Distorted or badly worn

6) ASSEMBLY

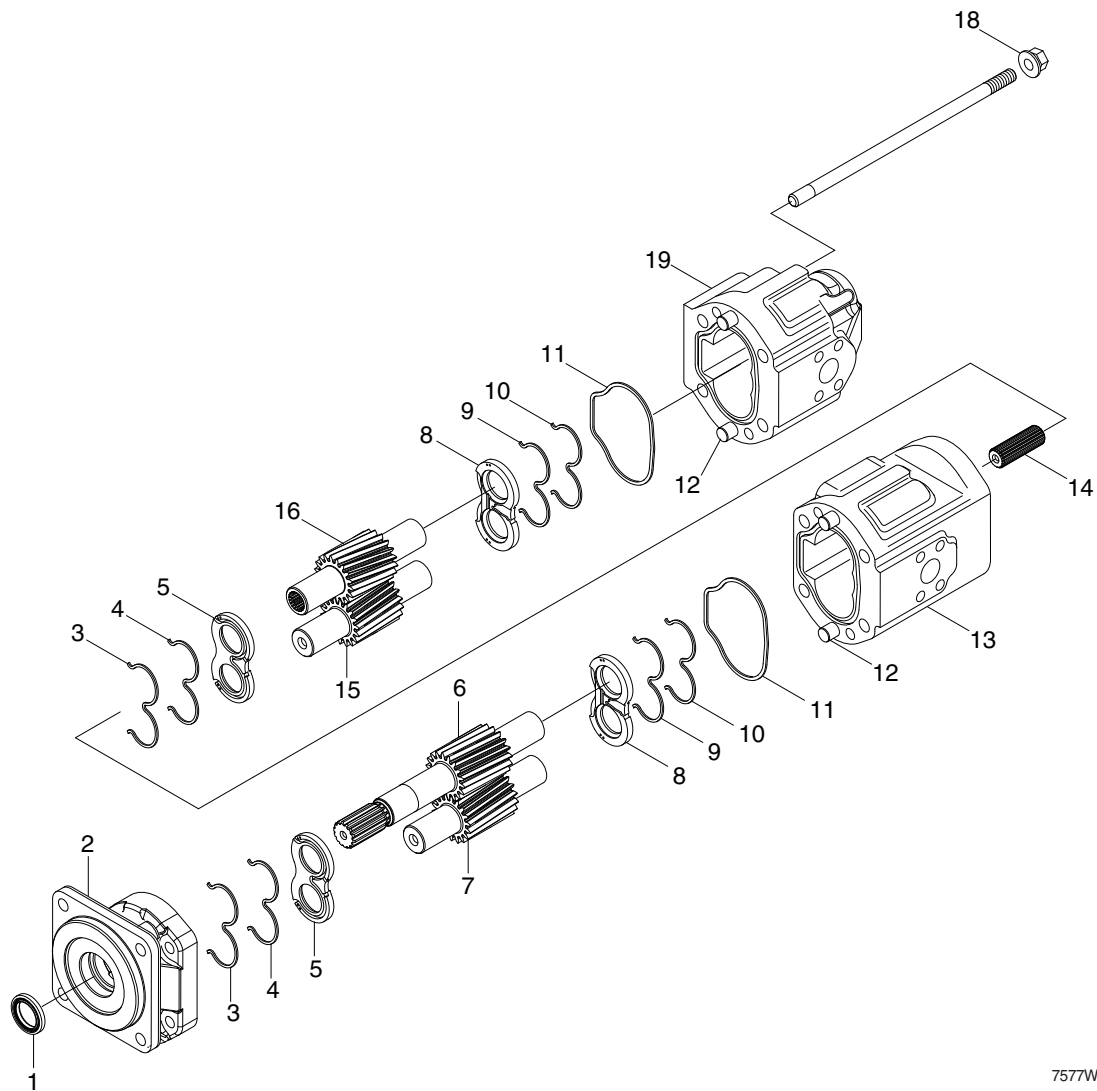

7577WE33

- ※ It is critical that the wearplates are assembled into the pump with regard to the following:
 - The seal side of the wearplate must be adjacent to the adaptor or body.
 - The high pressure side of the wearplate must be adjacent to the outlet port.
- ※ This must take place in a clean dry area, ensuring that all parts are clean and free from contamination or loose particles. Lightly oil all surfaces.
- (1) Place body vertically with gear pockets upper most.
- (2) Slide wearplate (8) complete with O-ring seal (9) and back up seal (10) down through the housing to the bottom of the gear pockets.
- ※ Be sure to refit the wearplate the same as that marked from this position during disassembly.
- (3) Fit the gears (15,16) within the housing taking care to replace as marked, with the teeth reassembled to their original related position.
- (4) Fit the wearplate (5) complete with O-ring seal (4) and back up seal (3).
- ※ Be sure to refit the wearplate the same as that marked from this position during disassembly.

ASSEMBLY

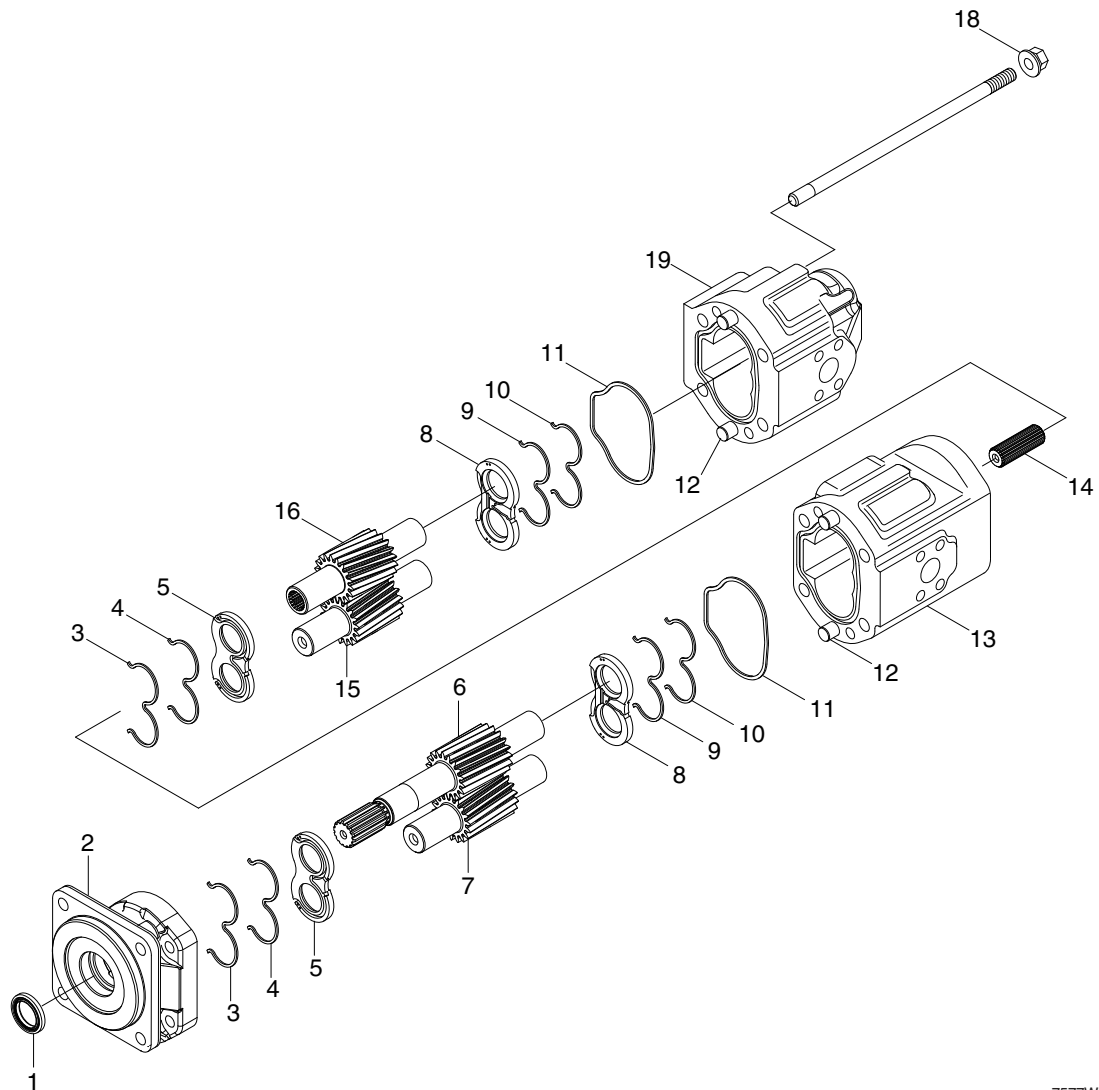

7577WE33

- (5) Fit new interface seal (11) into groove in body.
- (6) Proceed as per paragraph (1)~(2).
- (7) Fit adapter (2) over the drive gear (6) and fit stud (17).
- (8) Securely clamp unit and tighten nut (18) to half torque and then full torque.
 - Tightening torque : 23.2 kgf · m (168 lbf · ft)
- (9) Fit shaft seal (1) using appropriate tooling, in correct position and orientation.
- (10) Pour a little clean hydraulic oil into the ports.

2. MAIN CONTROL VALVE

1) STRUCTURE

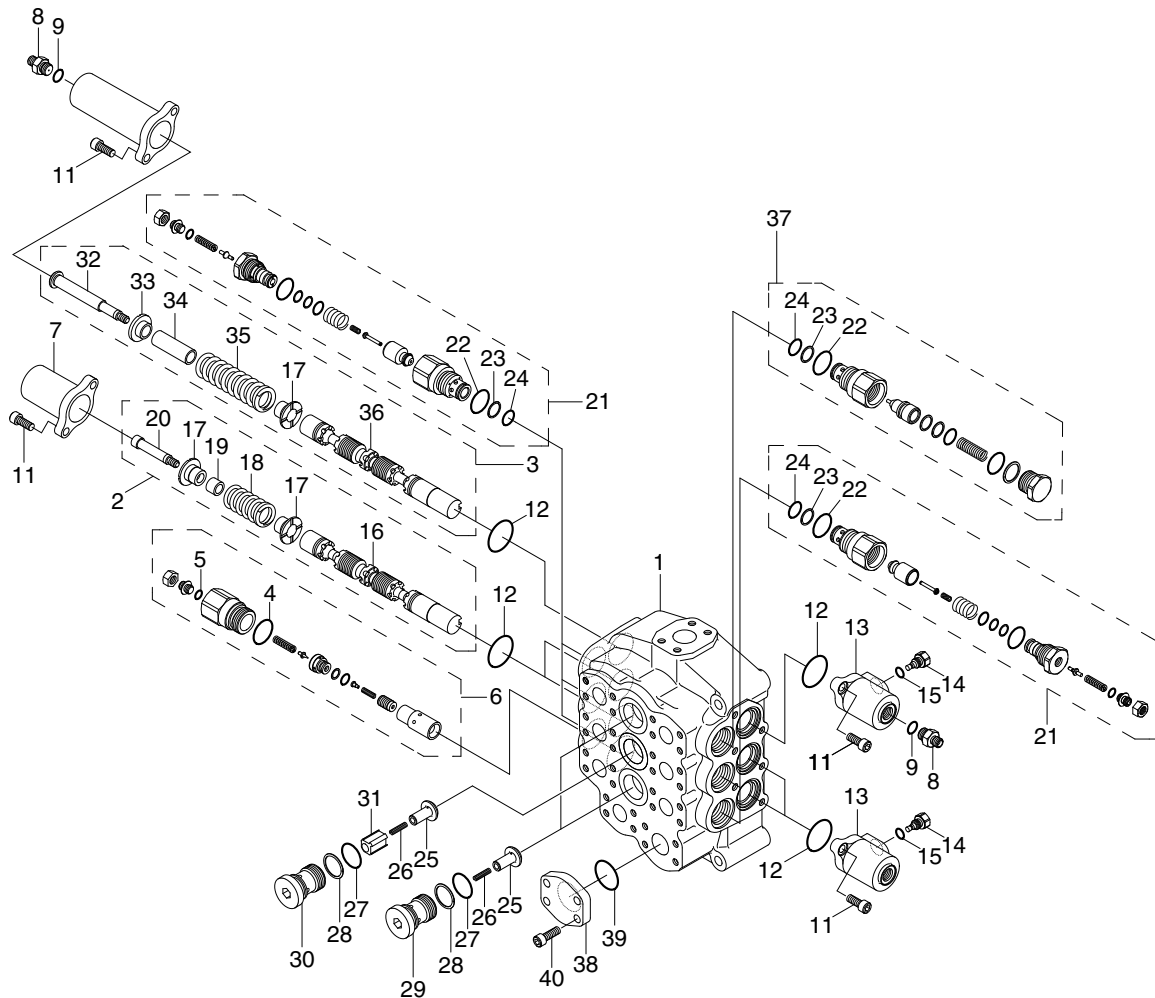

7607WE35

1	Housing assembly	15	O-ring	29	Cap
2	Plunger assembly	16	Plunger	30	Cap
3	Plunger assembly	17	Guide	31	Check
4	O-ring	18	Spring	32	Cap
5	O-ring	19	Spacer	33	Guide
6	Main relief assembly	20	Nipple	34	Spacer
7	Cover	21	Port relief assembly	35	Spring
8	Nipple	22	O-ring	36	Plunger
9	O-ring	23	Back up ring	37	Make up assembly
10	Cover	24	O-ring	38	Cover
11	Socket bolt	25	Check	39	O-ring
12	O-ring	26	Spring	40	Bolt
13	Cover	27	O-ring		
14	Plug	28	Back up ring		

2) GENERAL PRECAUTIONS

- (1) Clean room with no dust is recommended for maintenance. Because hydraulic components are precision, and have minute clearance. Tool and wash-oil must be clean, too. Handle them carefully.
- (2) At removing control valve from the machine, wash around the piping port, and neither dust nor water should go into inside with plugging. It is same at attaching the machine.
- (3) Prepare the required parts by checking structure figure before assembly. There are parts which are supplied with only sub-assembly part, so check the parts list before assembly.

3) PRECAUTIONS FOR DISASSEMBLY

- (1) Handle the components carefully not to drop them or bump them with each other as they are made with precision.
- (2) Do not force the work by hitting or twisting as burred or damaged component may not be assembled or result in oil leakage or low performance.
- (3) When disassembled, tag the components for identification so that they can be reassembled correctly.
- (4) Once disassembled, O-ring and back-up rings are usually not to be used again (remove them using a wire with its end made like a shoe-horn. Be careful not to damage the slot).
- (5) If the components are left disassembled or half-disassembled, they may get rust from moisture or dust. If the work has to be interrupted, take care to prevent rust and dust.

4) PRECAUTIONS FOR REASSEMBLY

- (1) Take the same precautions as for disassembly.
- (2) When assembling the components, remove any metal chips or foreign objects and check them for any burrs or dents. Remove burrs and dents with oil-stone, if any.
- (3) O-rings and back-up rings are to be replaced with new ones, as a rule.
- (4) When installing O-rings and back-up rings, be careful not to damage them (apply a little amount of grease for smoothness).
- (5) Tighten the bolts and caps with specified torque.

5) SPECIAL TOOL

· HOLDER

Material : copper

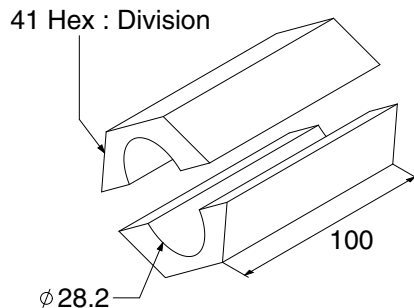

- ※ Regarding to change the main plunger
- We can not supply the main plunger, because the plunger is fit for valve housing.
- So, do not change the plunger at the field.
- If changing plunger must be needed, then tell us model name of control valve and serial number written at its nameplate.

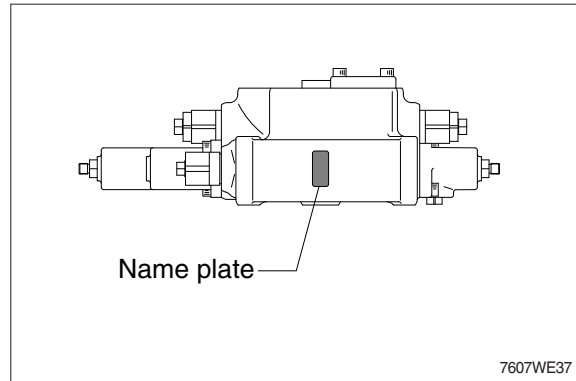

6) BUCKET PLUNGER AND ACCESSORY PLUNGER

- ※ Reassemble in the opposite order to disassemble.
- ※ To reassemble correctly, attach an identification tag immediately after parts are removed.

- (1) Remove hexagon socket bolts (1) then remove cover (2).
 - Hexagon socket bolt
 - Width across flat : 8 mm
 - Tightening torque : 5.1 kgf · m (36.8 lbf · ft)

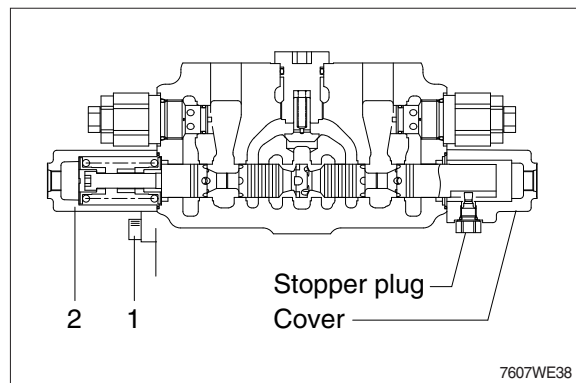

- ※ Reassembly
- Install cover (2), after making sure that O-ring is placed on the edge of the housing hole.

- (2) Pull out spool assembly from housing.

- ※ Do not pull out the spool all at once.
- Pull slowly while fitting in the housing hole.
- ※ Reassembly
- Set the key groove of the plunger with the stopper plug of the cover.

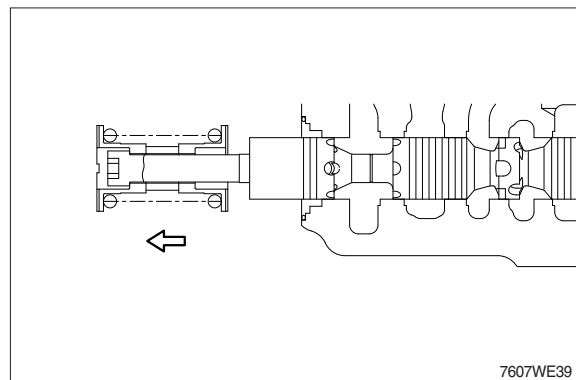

- (3) Set the spool between holders and loosen plunger cap (3) by using vise.
 - Plunger cap
 - Width across flat : 8 mm
 - Tightening torque : 6.1 kgf · m (44.2 lbf · ft)

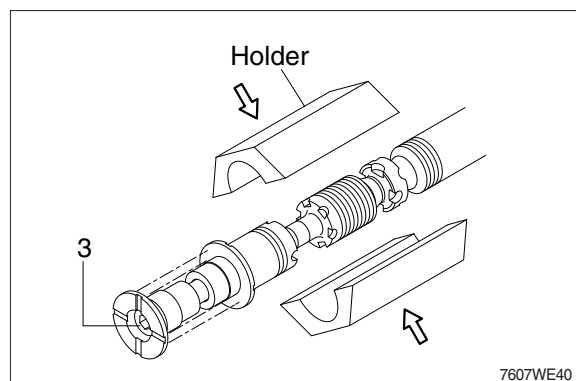

- ※ Set the spool between holders and clamp them by a vise after degreasing the spool and holders as a special tool.

- (4) Remove the plunger cap (3), spring guide (4), spring (6) and sleeve (5).

※ Spring is different from boom section spring.

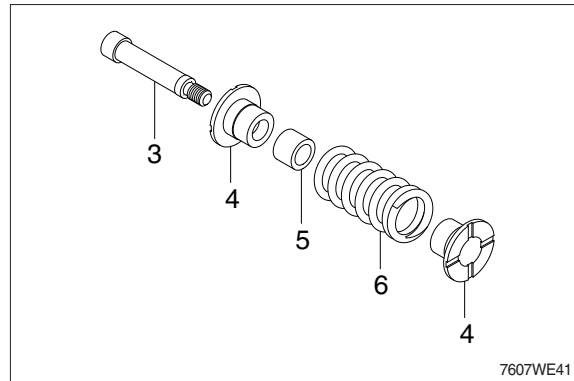

7607WE41

- (5) Remove hexagon socket bolts (8) then remove cover (9) after remove plug (7).

· Plug (7)

Width across flat : 19 mm

Tightening torque : 8.2 kgf · m (59.0 lbf · ft)

· Hexagon socket bolt (8)

Width across flat : 8 mm

Tightening torque : 5.1 kgf · m (36.8 lbf · ft)

※ Make sure that O-ring is on the face of housing.

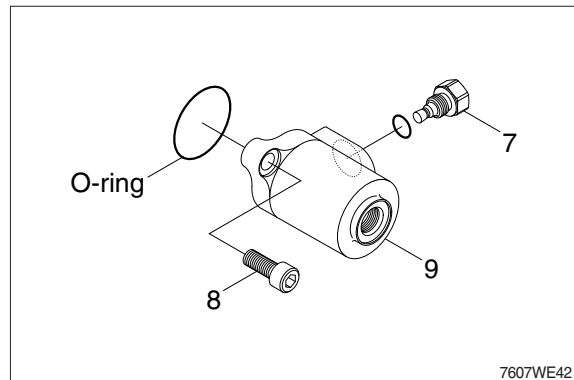

7607WE42

7) BOOM PLUNGER

- (1) Remove hexagon socket bolts (1) then remove cover (2).

· Hexagon socket bolt

Width across flat : 8 mm

Tightening torque : 5.1 kgf · m (36.8 lbf · ft)

※ Reassembly

Install cover (2), after making sure that O-ring is placed on the edge of the housing hole.

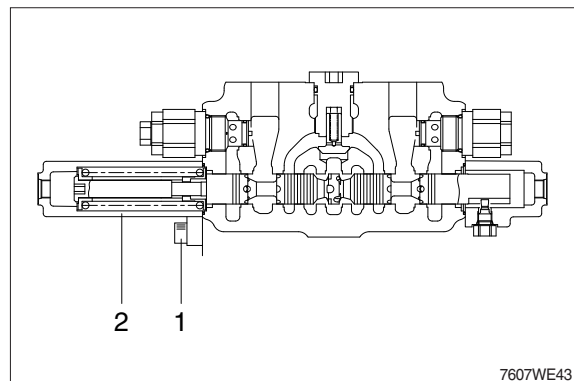

7607WE43

- (2) Pull out spool assembly from housing.

※ Do not pull out the spool all at once. Pull slowly while fitting in the housing hole.

※ Reassembly

Set the key way of the plunger to the stopper plug of the cover.

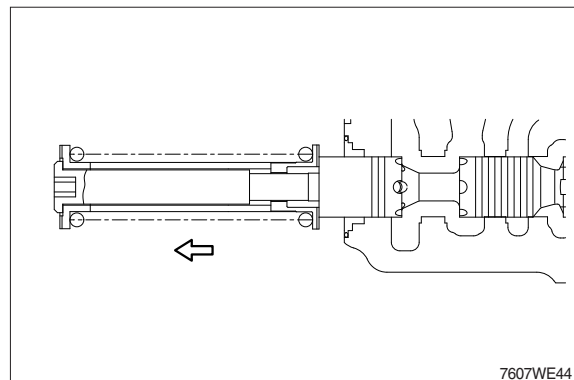

7607WE44

- (3) Set the spool between holders and loosen plunger cap (3) by using vise.

- Plunger cap

Width across flat : 8 mm

Tightening torque : 6.1 kgf · m (44.2 lbf · ft)

- ※ Set the spool between holders and clamp them by a vise after degreasing the spool and holders as a special tool.

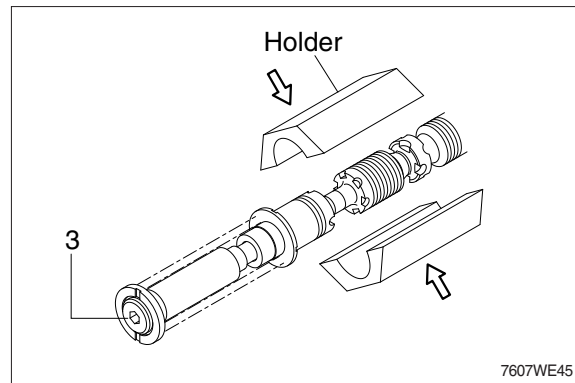

- (4) Remove the plunger cap (3), spring guide (4), spring (6), sleeve (5) and spring guide (7).

- ※ Spring is different from the other section spring.

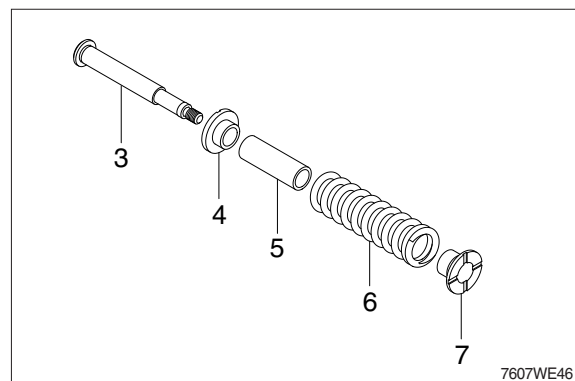

- (5) Remove hexagon socket bolts (9) then remove cover (10) after remove plug (8).

- Plug (8)

Width across flat : 19 mm

Tightening torque : 8.2 kgf · m (59.0 lbf · ft)

- Hexagon socket bolt (9)

Width across flat : 8 mm

Tightening torque : 5.1 kgf · m (36.8 lbf · ft)

- ※ Confirm that O-ring is put to end face of housing.

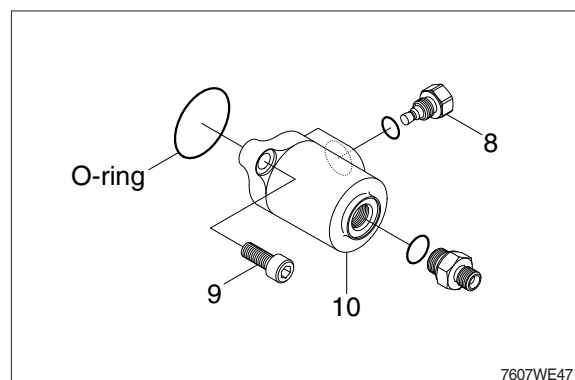

8) MAIN RELIEF VALVE

- (1) Loosen cap (1) and remove the main relief cartridge from the body.

- Cap (1)

Width across flat : 41 mm

Tightening torque : 10.2 kgf · m (73.8 lbf · ft)

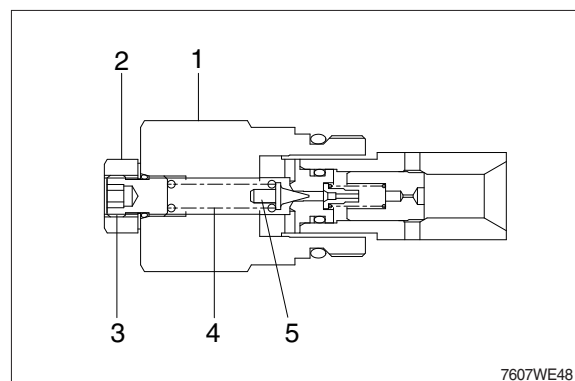

(2) Loosen hex nut (2), and remove adjust screw (3), spring (4) and pilot poppet (5).

· Hex nut (2)

Width across flat : 19 mm

Tightening torque : 3.3 kgf · m (23.6 lbf · ft)

· Adjust screw (3)

Width across flat : 22 mm

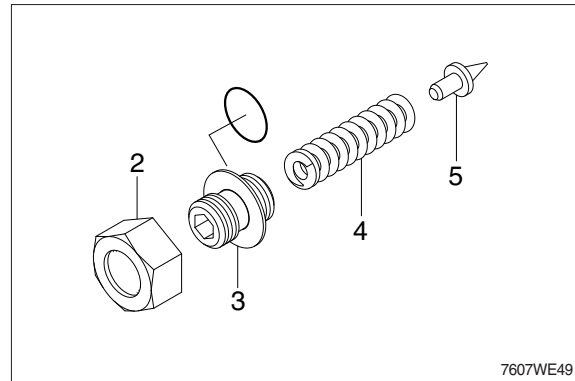

(3) Pull out sleeve (9), and remove orifice (6), spring (7) and main poppet (8).

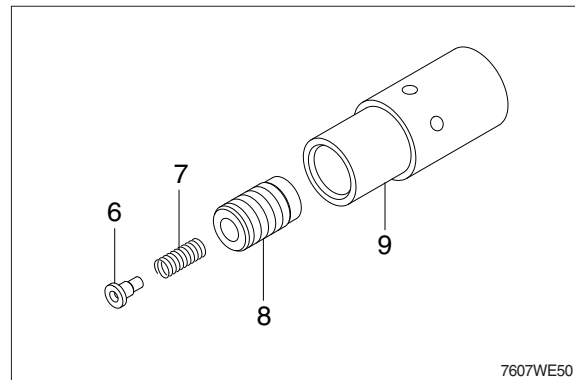

※ Do not disassemble pilot seat, because the pilot seat is assembled with pressure.

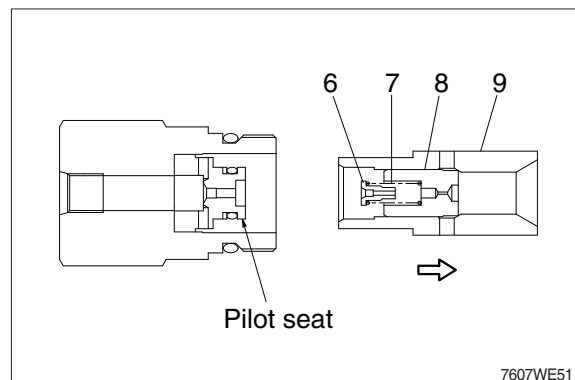

(5) RESETTING THE RELIEF PRESSURE

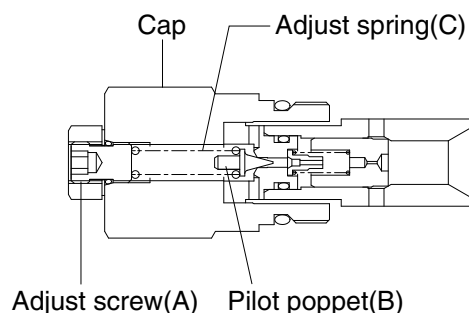

7607WE52

- ※ If setting pressure is mistaken, hydraulic unit may be destroyed and danger may be caused.
Do not raise by any means more than the pressure decided for every model.

Temporary assembly and setting

- ① Check the position of setting pressure 0 MPa.
Set adjusting screw (A) temporarily in the position that pilot poppet (B) contacts to pilot seat.
Then pressure adjusting spring (C) begins to be effective.
- ② Install the main relief valve which is set temporarily to main body.
Tighten cap with torque wrench.
 - Tightning torque : 10.2 kgf · m (73.8 lbf · ft)

To set pressure

- ① Attach exact pressure gauge at exit of pump or gauge port of control valve.
 - ② Operate the pump with rated speed.
 - ③ Operate plunger either boom or bucket at full stroke and check the pressure.
 - ④ Turn adjusting screw (A) (right turn) and set pressure with checking pressure gauge.
 - One quarter turn of adjusting screw (A) equals about 4 MPa.
 - Setting pressure 20.6 MPa (210 kgf/cm²) at 220 l /min.
 - Relief is very sensitivity. So, do not turn adjusting screw (A) suddenly.
 - ⑤ Tighten lock nut with torque wrench holding adjusting screw.
 - Tightning torque : 3.3 kgf · m (23.6 lbf · ft)
- ※ Operate plunger and check the setting pressure, again.

9) PORT RELIEF VALVE

- ※ Do not disassemble adjusting screw.
It's impossible to readjust setting pressure exactly on the machine.

(1) Loosen sleeve (1) and remove relief valve.

- Sleeve (1)

Width across flat : 41 mm

Tightening torque : 10.2 kgf · m (73.8 lbf · ft)

- ※ Install to original position.

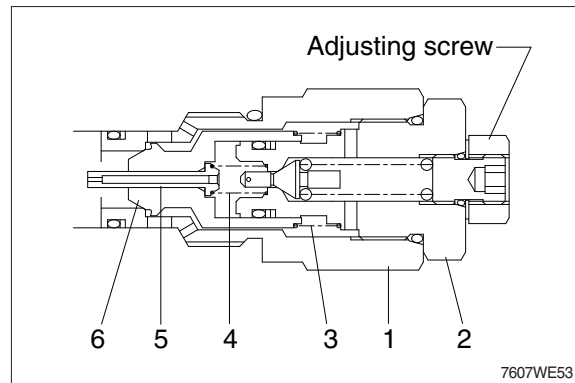

(2) Loosen and remove relief seat sub-assembly (2). And remove spring (3),(4) piston (5), and main poppet (6).

- Relief seat (2)

Width across flat : 36 mm

Tightening torque : 10.2 kgf · m (73.8 lbf · ft)

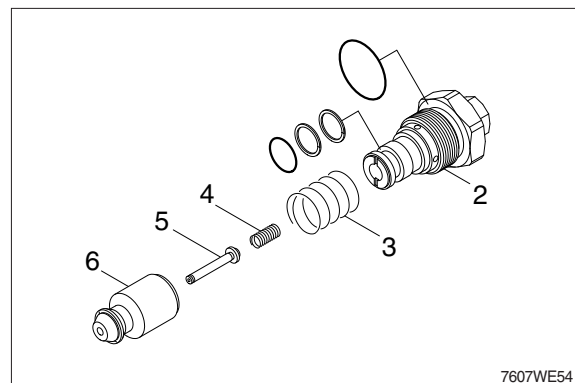

10) MAKE UP VALVE

(1) Loosen sleeve (1) and remove relief valve.

- Sleeve (1)

Width across flat : 41 mm

Tightening torque : 10.2 kgf · m (73.8 lbf · ft)

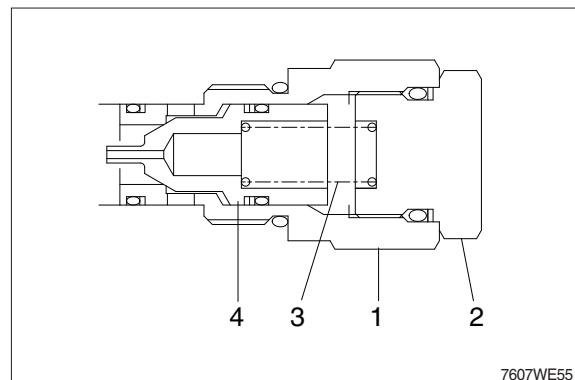

(2) Remove cap (2) and pull out spring (3), poppet (4).

- Cap (2)

Width across flat : 36 mm

Tightening torque : 10.2 kgf · m
(73.8 lbf · ft)

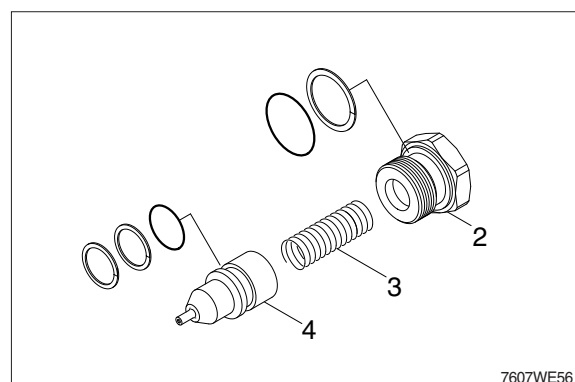

11) LOAD CHECK VALVE

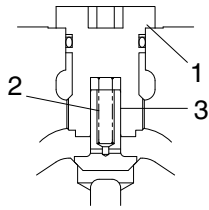

- Bucket for 2-spools valve
- Aux for 3-spools valve
- Boom for 2 & 3-spools valve

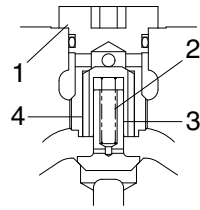

- Bucket for 3-spools valve

7607WE57

Example for explanation : Bucket section of 3-spools valve (double check)

- (1) Remove cap (1) pull out spring (2), check (3) and (4)

- Cap (2)

Width across flat : 36 mm

Tightening torque : 25.5 kgf · m (184 lbf · ft)

- ※ When reassembly ;
Be careful for the back-up ring not to protrude.
- ※ Only Bucket section has double check.

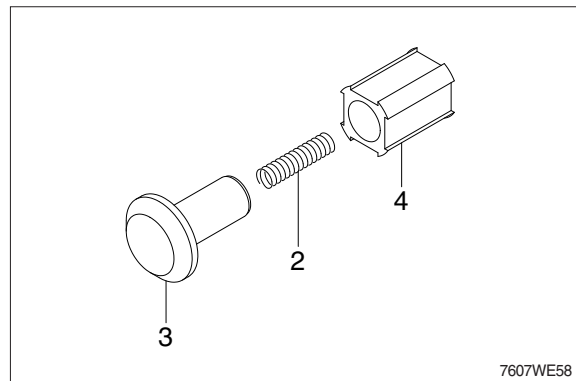

7607WE58

3. REMOTE CONTROL VALVE

1) STRUCTURE

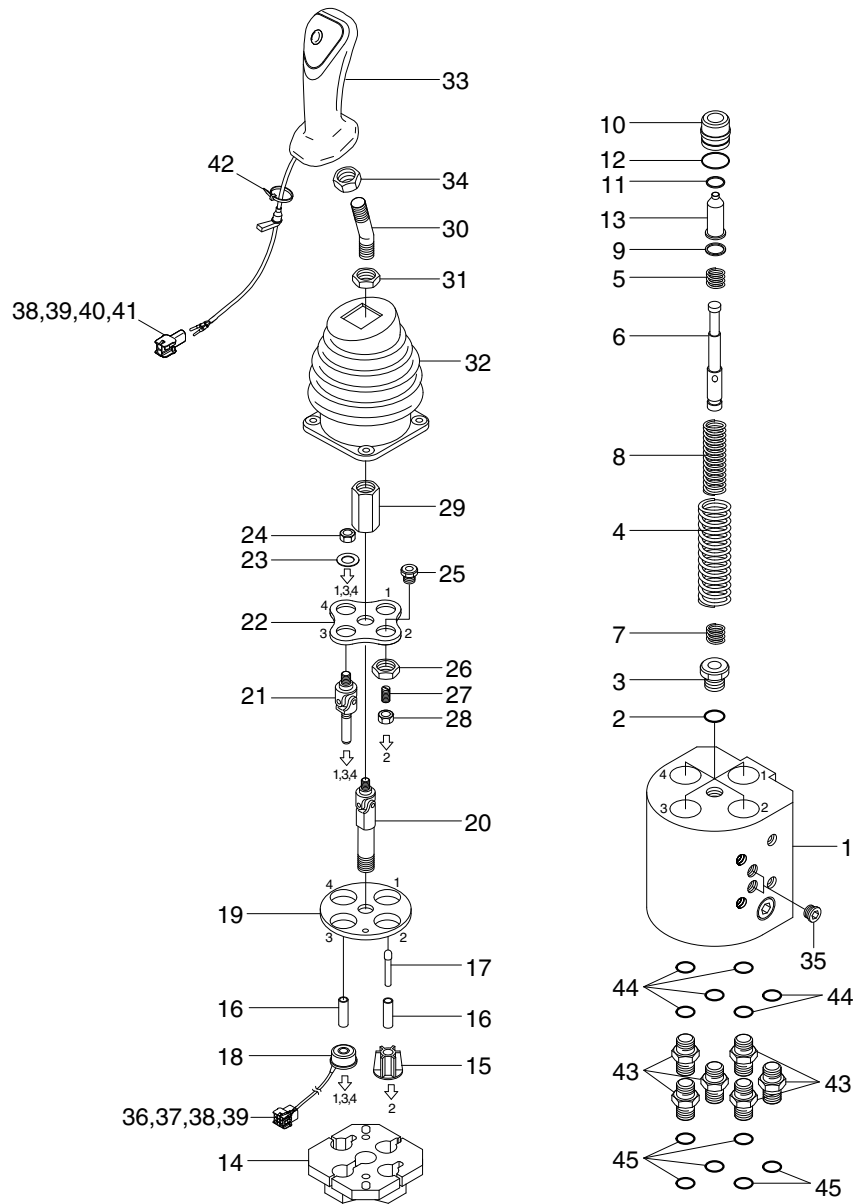

7607B6WE48

1	Body	13	Push rod	25	Plug	37	Rear holder
2	O-ring	14	Plate	26	Nut	38	Terminal
3	Plug	15	Rod stopper	27	Set screw	39	Seal wire
4	Spring	16	Bushing	28	Nut	40	2 Pin connector
5	Spring seat	17	Rod	29	Nut	41	Rear holder
6	Spool	18	Magnet	30	Handle bar	42	Clip band
7	Spring seat	19	Plate	31	Nut	43	Connector
8	Spring	20	Joint assy	32	Boot	44	O-ring
9	Stooper	21	Joint assy	33	Handle assy	45	O-ring
10	Plug	22	Plate	34	Nut		
11	Rod seal	23	Washer	35	Plug		
12	O-ring	24	Nut	36	6 Pin connector		

2) DISASSEMBLY

(1) Remove the boots (32) and loosen nut (31).

- Tool : spanner 19 mm



7607BRCV01



7607BRCV02

(2) Remove nut (29).



7607BRCV03

(3) Disassemble plate kit.



7607BRCV04

(4) Remove rod (17).



7607BRCV05

(5) Remove joint assembly (20).

· Tool : Spanner 17 mm



7607BRCV06

(6) Disassemble plate (19).



7607BRCV07

(7) Disassemble magnet (18) and rod stopper (15).

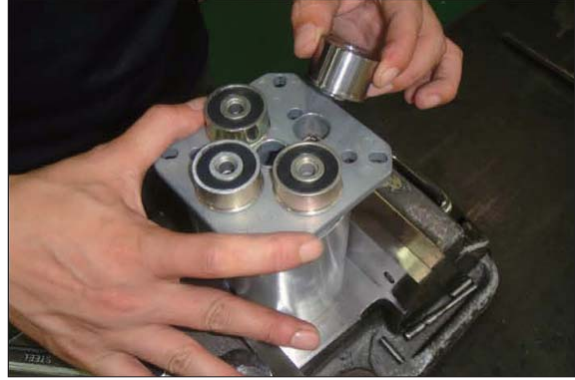

7607BRCV08

(8) Disassemble plate (14).

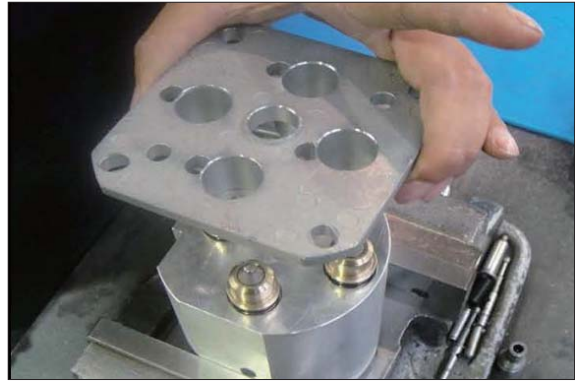

7607BRCV09

(9) Disassemble plug kit.



7607BRCV10

(10) Disassemble spring (4) and spool kit.

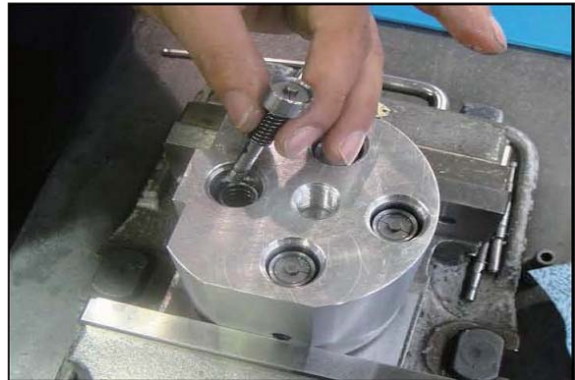

7607BRCV11

- (11) Disassemble plug (2).
- Tool : Wrench 10 mm



7607BRCV12

3) ASSEMBLY

- (1) Coat oil on O-ring and mount plug (3) into body assembly (1).



7607BRCV13

- (2) Tighten the plug (3).

- Tool : Wrench 10 mm
- Tightening torque : $30 \pm 3 \text{ kgf} \cdot \text{m}$
($217 \pm 21.7 \text{ lbf} \cdot \text{ft}$)



7607BRCV14

- (3) Assemble spring (4).



7607BRCV15

- (4) Assemble spool kit.



7607BRCV16

(5) Assemble plug kit.



7607BRCV17

(6) Assemble plate (14).

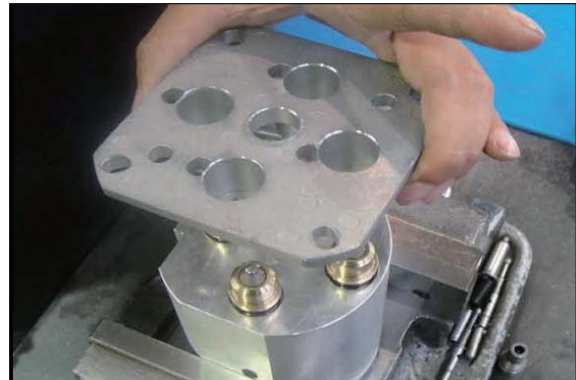

7607BRCV09

(7) Assemble magnet (18) at port 1, 3 and 4.
Assemble rod stopper (15) at port 2.

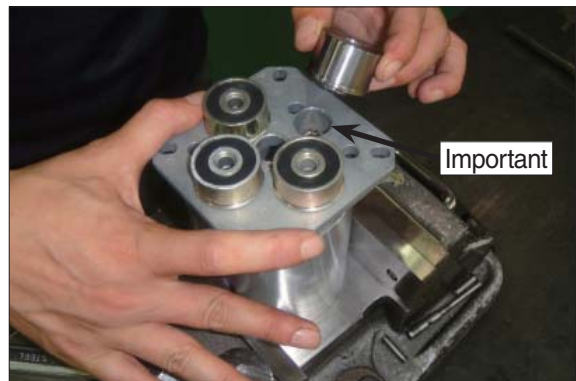

7607BRCV19

(8) Confirm port 2 on the bottom of the body.

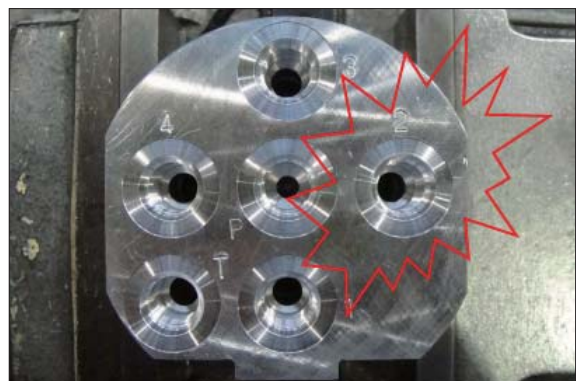

7607BRCV20

(9) Assemble plate (19).



7607BRCV21

(10) Assemble joint assembly (20) and put grease on joint pin lightly.

- Tools : spanner 17 mm
- Tightening torque (M16) :
 $45 \pm 4.5 \text{ kgf} \cdot \text{m}$ ($325 \pm 32.5 \text{ lbf} \cdot \text{ft}$)



7607BRCV22



7607BRCV23

(11) Assemble rod (17).



7607BRCV24

(12) Assemble plate kit.

Put a bit of grease on rod (17) and Joint (21).



7607BRCV04

(13) Assemble nut (29).

- Tool : spanner 17 mm
- Tightening torque :
 $40 \pm 4 \text{ kgf} \cdot \text{cm}$ ($289 \pm 28.9 \text{ lbf} \cdot \text{ft}$)



7607BRCV03



7607BRCV02

(14) Assembled nut (31).

- Tool : spanner 19 mm
- Tightening torque (M12) :
 $40 \pm 4 \text{ kgf} \cdot \text{cm}$ ($28 \pm 28.9 \text{ lbf} \cdot \text{ft}$)



7607BRCV01

(15) Assemble the boots (32).



7607BRCV25