

# GROUP 2 SPECIFICATION

## 1. MAJOR COMPONENT

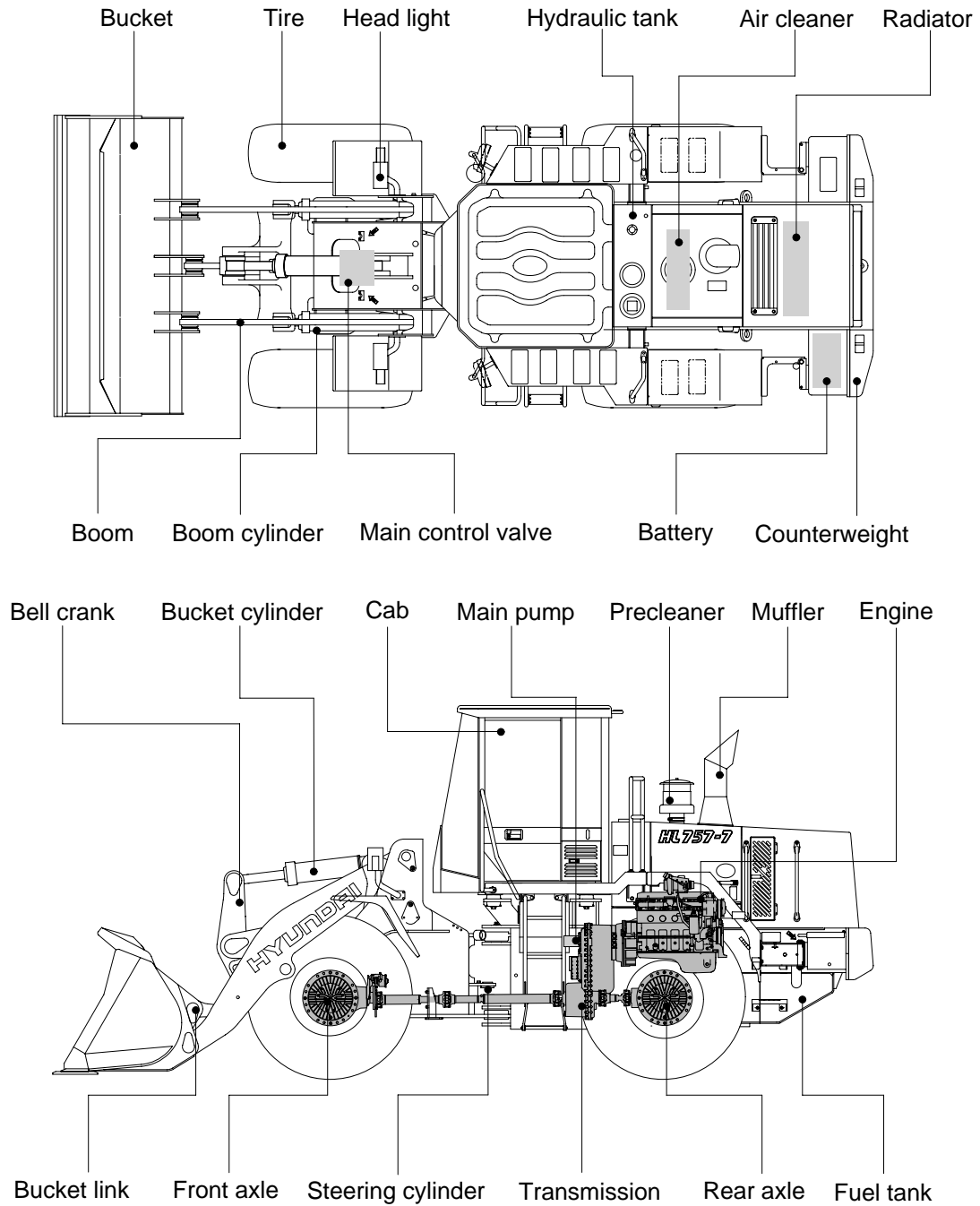

7572SE01

## 2. SPECIFICATIONS

### 1) WITHOUT TOOTH AND CUTTING EDGE TYPE BUCKET

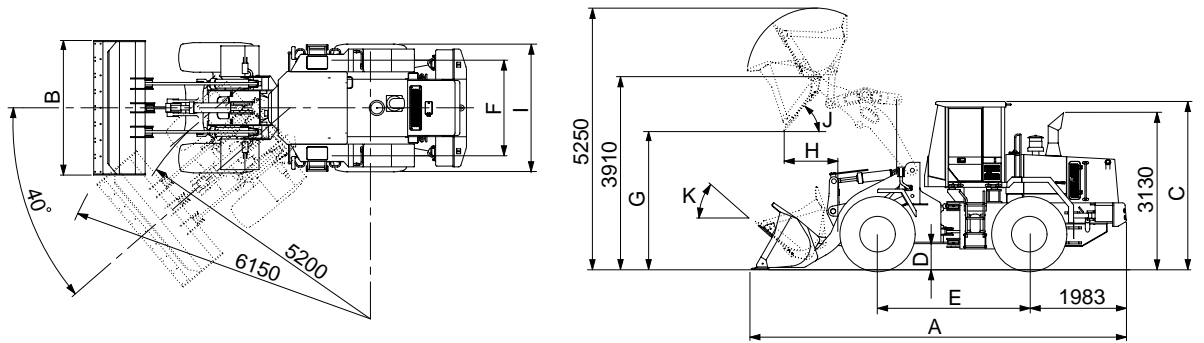

7572SE02

Description		Unit	Specification	
Operating weight		kg(lb)	13800(30420)	
Bucket capacity	Struck	m <sup>3</sup> (yd <sup>3</sup> )	2.3(3.0)	
	Heaped		2.7(3.5)	
Overall length	A	mm(ft-in)	7350(24' 1")	
Overall width	B		2740( 9' 0")	
Overall height	C		3300(10'10")	
Ground clearance	D		410( 1' 4")	
Wheelbase	E		3030( 9'11")	
Tread	F		2050( 6' 9")	
Dump clearance at 45°	G		2930( 9' 7")	
Dump reach(Full lift)	H		1005( 3' 4")	
Width over tires	I		2580( 8' 6")	
Dump angle	J		Degree (°)	47
Roll back angle(Carry position)	K			46
Cycle time	Lift(With load)	sec	5.9	
	Dump(With load)		1.2	
	Lower(Empty)		3.2	
Maximum travel speed		km/hr(mph)	37.0(23.0)	
Braking distance		m(ft-in)	12(39' 4")	
Minimum turning radius(Center of outside tire)			5.2(17' 1")	
Gradability		Degree (°)	30	
Travel speed	Forward	km/hr(mph)	First gear	7.4(4.6)
			Second gear	12.1(7.5)
			Third gear	23.7(14.7)
			Fourth gear	37.0(23.0)
	Reverse		First gear	7.8(4.9)
			Second gear	12.8(8.0)
Third gear		25(15.6)		

## 2) WITH BOLT-ON CUTTING EDGE TYPE BUCKET

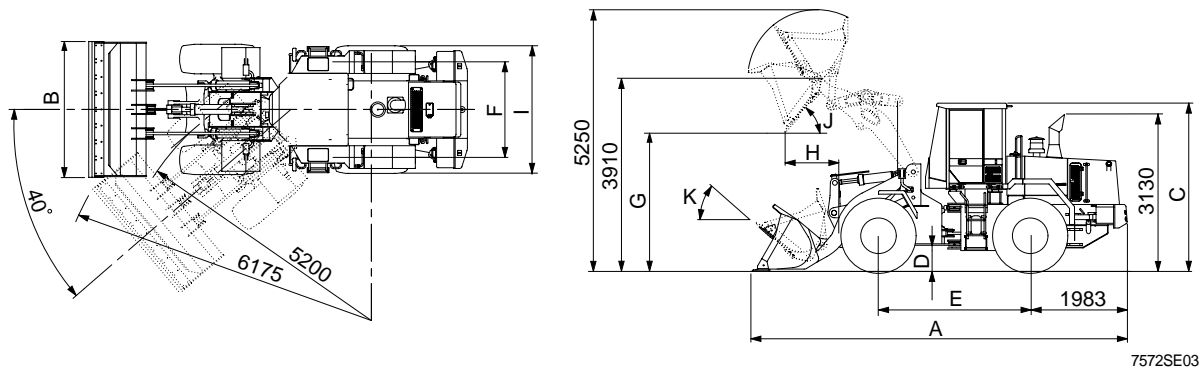

7572SE03

Description		Unit	Specification	
Operating weight		kg(lb)	13800(30420)	
Bucket capacity	Struck	m <sup>3</sup> (yd <sup>3</sup> )	2.43(1)	
	Heaped		2.8(3.7)	
Overall length	A	mm(ft-in)	7450(24' 5")	
Overall width	B		2740( 9' 0")	
Overall height	C		3300(10'10")	
Ground clearance	D		410( 1' 4")	
Wheelbase	E		3030( 9'11")	
Tread	F		2050( 6' 9")	
Dump clearance at 45°	G		2860( 9' 5")	
Dump reach(Full lift)	H		1040( 3' 4")	
Width over tires	I		2580( 8' 6")	
Dump angle	J		Degree (°)	47
Roll back angle(Carry position)	K			46
Cycle time	Lift(With load)	sec	5.9	
	Dump(With load)		1.2	
	Lower(Empty)		3.2	
Maximum travel speed		km/hr(mph)	37.0(23.0)	
Braking distance		m(ft-in)	12(39' 4")	
Minimum turning radius(Center of outside tire)			5.2(17' 1")	
Gradability		Degree (°)	30	
Travel speed	Forward	km/hr(mph)	First gear	7.4(4.6)
			Second gear	12.1(7.5)
			Third gear	23.7(14.7)
			Fourth gear	37.0(23.0)
	Reverse		First gear	7.8(4.9)
			Second gear	12.8(8.0)
Third gear		25(15.6)		

### 3) WITH TOOTH TYPE BUCKET

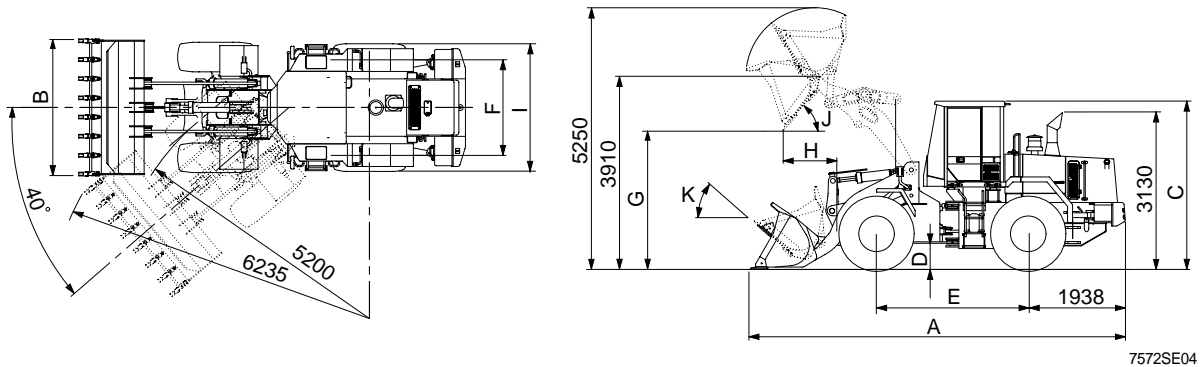

Description		Unit	Specification	
Operating weight		kg(lb)	13800(30420)	
Bucket capacity	Struck	m <sup>3</sup> (yd <sup>3</sup> )	2.3(3.0)	
	Heaped		2.6(3.4)	
Overall length	A	mm(ft-in)	7550(24' 9")	
Overall width	B		2790( 9' 2")	
Overall height	C		3300(10'10")	
Ground clearance	D		410( 1' 4")	
Wheelbase	E		3030( 9'11")	
Tread	F		2050( 6' 9")	
Dump clearance at 45°	G		2775( 9' 1")	
Dump reach(Full lift)	H		1125( 3' 8")	
Width over tires	I		2580( 8' 6")	
Dump angle	J		Degree (°)	47
Roll back angle(Carry position)	K			46
Cycle time	Lift(With load)	sec	5.9	
	Dump(With load)		1.2	
	Lower(Empty)		3.2	
Maximum travel speed		km/hr(mph)	37.0(23.0)	
Braking distance		m(ft-in)	12(39' 4")	
Minimum turning radius(Center of outside tire)			5.2(17' 1")	
Gradability		Degree (°)	30	
Travel speed	Forward	First gear	7.4(4.6)	
		Second gear	12.1(7.5)	
		Third gear	23.7(14.7)	
		Fourth gear	37.0(23.0)	
	Reverse	First gear	7.8(4.9)	
		Second gear	12.8(8.0)	
Third gear		25(15.6)		

### 3. WEIGHT

Item	kg	lb
Front frame assembly	1157	2551
Rear frame assembly	1573	3468
Front fender(LH & RH)	77	170
Counterweight	560	1235
Cab assembly	1020	2249
Engine assembly	432	952
Transmission assembly	470	1036
Drive shaft(Front)	19	42
Drive shaft(Center)	15	33
Drive shaft(Rear)	11	24
Front axle(Include differential)	526	1160
Rear axle(Include differential)	766	1689
Tire(20.5-25, 16PR, L3)	203	448
Hydraulic tank assembly	203	448
Fuel tank assembly	352	776
Main pump assembly	37	82
Fan & brake pump assembly	7	15
Main control valve	51	112
Steering valve(EHPS)	15	33
Boom assembly	980	2161
Bell crank assembly	264	582
Bucket link	45	99
3.1m <sup>3</sup> bucket, with bolt on cutting edge	1150	2535
3.0m <sup>3</sup> bucket, with tooth	1090	2403
3.0m <sup>3</sup> bucket, without tooth and cutting edge	1135	2502
Boom cylinder assembly	108	238
Bucket cylinder assembly	122	269
Steering cylinder assembly	29	64
Seat	40	88
Battery	55	121

#### 4. SPECIFICATION FOR MAJOR COMPONENTS

##### 1) ENGINE

Item	Specification
Model	Cummins QSB5.9-C
Type	4-cycle turbocharged, diesel engine
Control type	Electronic control
Cooling method	Water cooling
Number of cylinders and arrangement	6 cylinders, in-line
Firing order	1-5-3-6-2-4
Combustion chamber type	Direct injection type
Cylinder bore x stroke	102 x 120mm(4.02" x 4.72")
Piston displacement	5880cc(359cu in)
Compression ratio	17.5 : 1
Rated gross horse power	175ps at 2200rpm
Maximum gross torque at 1500rpm	82kgf · m(590lbf · ft)
Engine oil quantity	16 (4.2 U.S. gal)
Wet weight	432kg(952lb)
High idling speed	2330 ± 50rpm
Low idling speed	950 ± 50rpm
Rated fuel consumption	166g/ps · hr
Starting motor	Nippondenso 228000-7902 (24V-7.5kW)
Alternator	Delco Remy 22SI(24V-70Amp)
Battery	2 x 12V x 160Ah

## 2) MAIN PUMP

Item	Specification
Type	Fixed displacement double helical gear pump
Capacity	51+51cc/rev
Maximum operating pressure	210kgf/cm <sup>2</sup> (2990psi)
Rated oil quantity	220 l /min(58.1U.S.gpm / 48.4U.K.gpm)
Rated speed	2200rpm

## 3) FAN + BRAKE PUMP

Item	Specification	
	FAN	BRAKE
Type	Fixed displacement double helical gear pump	
Capacity	19cc/rev	9.5cc/rev
Maximum operating pressure	115kgf/cm <sup>2</sup> (1640psi)	150kgf/cm <sup>2</sup> (2130psi)
Rated oil quantity	40 l /min(10.6U.S.gpm)	20 l /min(5.3U.S.gpm)
Rated speed	2200rpm	

## 4) MAIN CONTROL VALVE

Item	Specification
Type	2 spool
Operating method	Hydraulic pilot assist
Main relief valve pressure	210kgf/cm <sup>2</sup> (2990psi)
Overload relief valve pressure	240kgf/cm <sup>2</sup> (3410psi)

## 5) REMOTE CONTROL VALVE

Item	Specification	
Type	Pressure reducing type	
Operating	Minimum	5.8kgf/cm <sup>2</sup> (82.5psi)
	Maximum	19kgf/cm <sup>2</sup> (270psi)
Single operation stroke	Lever	70mm(2.8in)

## 6) CYLINDER

Item		Specification
Boom cylinder	Bore dia × Rod dia × Stroke	Ø 140 × Ø 75 × 750mm
Bucket cylinder	Bore dia × Rod dia × Stroke	Ø 160 × Ø 80 × 475mm
Steering cylinder	Bore dia × Rod dia × Stroke	Ø 70 × Ø 45 × 436mm

## 7) DYNAMIC POWER TRANSMISSION DEVICES

Item		Specification	
Transmission	Model	4WG190	
	Type	Converter	Single-stage, single-phase
		Transmission	Full-automatic power shift
	Gear shift	Forward fourth gear, reverse third gear	
	Adjustment	Electrical single lever type, kick-down system, user selective automatic kick down from 2nd to 1st gear	
Axle	Drive devices	4-wheel drive	
	Front	Front fixed location	
	Rear	Oscillation ± 13° of center pin-loaded	
Wheels	Tires	20.5-25, 16PR(L3)	
Brakes	Travel	Four-wheel, wet-disc type, full hydraulic	
	Parking	Spring applied, hydraulic released brake on front axle	
Steering	Type	Full hydraulic, articulated	
	Steering angle	40° to both right and left angle, respectively	



## 5. TIGHTENING TORQUE OF MAJOR COMPONENT

No	Items	Size	kgf · m	lbf · ft	
1	Engine	Engine mounting bolt(2EA)	M20 × 2.5	57.9 ± 8.7	419 ± 62.9
2		Engine mounting bolt(Bracket)	M12 × 1.75	10.7 ± 1.6	77.4 ± 11.6
3		Radiator mounting bolt	M16 × 2.0	29.7 ± 4.5	215 ± 32.5
4		Fuel tank mounting bolt	M16 × 2.0	29.7 ± 4.5	215 ± 32.5
5		Air cleaner mounting bolt	M 8 × 1.25	2.5 ± 0.5	18.1 ± 3.6
6	Hydraulic system	Main pump housing mounting bolt	M12 × 1.75	12.8 ± 3.0	92.6 ± 21.7
7		Main control valve mounting bolt	M12 × 1.75	12.8 ± 3.0	92.6 ± 21.7
8		Steering unit mounting bolt	M10 × 1.5	6.9 ± 1.4	49.9 ± 10.1
9		Steering valve mounting bolt	M 8 × 1.25	2.5 ± 0.5	18.1 ± 3.6
10		Brake valve mounting bolt	M 8 × 1.25	2.5 ± 0.5	18.1 ± 3.6
11		Fan and brake pump mounting bolt	M10 × 1.5	6.9 ± 1.4	49.9 ± 10.1
12		Cut-off valve mounting bolt	M12 × 1.75	12.8 ± 3.0	92.6 ± 21.7
13		Remote control lever mounting bolt	M 6 × 1.0	1.1 ± 0.2	8.0 ± 1.4
14		Pilot supply unit mounting bolt	M 8 × 1.25	2.5 ± 0.5	18.1 ± 3.6
15		Safety valve	M 8 × 1.25	2.5 ± 0.5	18.1 ± 3.6
16		Hydraulic oil tank mounting bolt	M16 × 2.0	29.7 ± 4.5	215 ± 32.5
17	Power train system	Transmission mounting bolt	M24 × 3.0	100 ± 15	723 ± 109
18		Transmission mounting bolt(Bracket)	M20 × 2.5	46.3 ± 7.0	335 ± 50.6
19		Torque converter housing mounting bolt	M10 × 1.5	4.6 ± 0.7	33.3 ± 5.1
20		Front axle mounting bolt, nut	M24 × 2.0	100 ± 15	723 ± 109
21		Rear axle support mounting bolt, nut	M27 × 2.0	135 ± 15	976 ± 108
22		Tire mounting nut	M22 × 1.5	79 ± 2.5	571 ± 18
23		Drive shaft joint mounting bolt	3/8-24UNF-48	5.95 ± 0.85	43.0 ± 6.1
24	Others	Counterweight mounting bolt	M30 × 2.0	199 ± 29.9	1439 ± 216
25		Operator's seat mounting bolt	M 8 × 1.25	3.4 ± 0.8	24.6 ± 5
26		ROPS Cab mounting bolt(4EA)	M27 × 2.0	124	900

## 6. TORQUE CHART

Use following table for unspecified torque.

### 1) BOLT AND NUT

#### (1) Coarse thread

Bolt size	8T		10T	
	kgf · m	lbf · ft	kgf · m	lbf · ft
M 6 × 1.0	0.85 ~ 1.25	6.15 ~ 9.04	1.14 ~ 1.74	8.2 ~ 12.6
M 8 × 1.25	2.0 ~ 3.0	14.5 ~ 21.7	2.73 ~ 4.12	19.7 ~ 29.8
M10 × 1.5	4.0 ~ 6.0	28.9 ~ 43.4	5.5 ~ 8.3	39.8 ~ 60
M12 × 1.75	7.4 ~ 11.2	53.5 ~ 79.5	9.8 ~ 15.8	71 ~ 114
M14 × 2.0	12.2 ~ 16.6	88.2 ~ 120	16.7 ~ 22.5	121 ~ 167
M16 × 2.0	18.6 ~ 25.2	135 ~ 182	25.2 ~ 34.2	182 ~ 247
M18 × 2.5	25.8 ~ 35.0	187 ~ 253	35.1 ~ 47.5	254 ~ 343
M20 × 2.5	36.2 ~ 49.0	262 ~ 354	49.2 ~ 66.6	356 ~ 482
M22 × 2.5	48.3 ~ 63.3	350 ~ 457	65.8 ~ 98.0	476 ~ 709
M24 × 3.0	62.5 ~ 84.5	452 ~ 611	85.0 ~ 115	615 ~ 832
M30 × 3.5	124 ~ 168	898 ~ 1214	169 ~ 229	1223 ~ 1655
M36 × 4.0	174 ~ 236	1261 ~ 1703	250 ~ 310	1808 ~ 2242

#### (2) Fine thread

Bolt size	8T		10T	
	kgf · m	lbf · ft	kgf · m	lbf · ft
M 8 × 1.0	2.17 ~ 3.37	15.7 ~ 24.3	3.04 ~ 4.44	22.0 ~ 32.0
M10 × 1.25	4.46 ~ 6.66	32.3 ~ 48.2	5.93 ~ 8.93	42.9 ~ 64.6
M12 × 1.25	7.78 ~ 11.58	76.3 ~ 83.7	10.6 ~ 16.0	76.6 ~ 115
M14 × 1.5	13.3 ~ 18.1	96.2 ~ 130	17.9 ~ 24.1	130 ~ 174
M16 × 1.5	19.9 ~ 26.9	144 ~ 194	26.6 ~ 36.0	193 ~ 260
M18 × 1.5	28.6 ~ 43.6	207 ~ 315	38.4 ~ 52.0	278 ~ 376
M20 × 1.5	40.0 ~ 54.0	289 ~ 390	53.4 ~ 72.2	386 ~ 522
M22 × 1.5	52.7 ~ 71.3	381 ~ 515	70.7 ~ 95.7	512 ~ 692
M24 × 2.0	67.9 ~ 91.9	491 ~ 664	90.9 ~ 123	658 ~ 890
M30 × 2.0	137 ~ 185	990 ~ 1338	182 ~ 248	1314 ~ 1795
M36 × 3.0	192 ~ 260	1389 ~ 1879	262 ~ 354	1893 ~ 2561

**2) PIPE AND HOSE(FLARE TYPE)**

Thread size(PF)	Width across flat(mm)	kgf · m	lbf · ft
1/4"	19	4	28.9
3/8"	22	5	36.2
1/2"	27	6	43.4
3/4"	36	12	86.8
1"	41	14	101

**3) PIPE AND HOSE(ORFS TYPE)**

Thread size(UNF)	Width across flat(mm)	kgf · m	lbf · ft
13/16-16"	24	4.4	32.5
1-3/16-12"	36	9.3	67.3
1-7/16-12"	41	13.2	95.5
1-11/16-12"	50	18.3	132.4
2-12"	55	22.6	163.5

**4) FITTING**

Thread size(PF)	Width across flat(mm)	kgf · m	lbf · ft
1/4"	19	4	28.9
3/8"	22	5	36.2
1/2"	27	6	43.4
3/4"	36	13	94.0
1"	41	15	109

## 7. RECOMMENDED LUBRICANTS

Use only oils listed below or equivalent.

Do not mix different brand oil.

Service point	Kind of fluid	Capacity (U.S. gal)	Ambient temperature °C(°F)						
			-20 (-4)	-10 (14)	0 (32)	10 (50)	20 (68)	30 (86)	40 (104)
Engine oil pan	Engine oil	16(4.2)	SAE 30						
			SAE 10W						
			SAE 10W-30						
			SAE 15W-40						
Transmission	Oil	43(11.4)	SAE 10W-30						
			SAE 15W-40						
Axle	Gear oil	Front : 29(7.7) Rear : 29(7.7)	SAE 80W-90LSD/API GL-5						
Hydraulic tank	Hydraulic oil	Tank: 130(34.3) System: 175(46)	ISO VG 32						
			ISO VG 46						
			ISO VG 68						
Fuel tank	Diesel fuel	319(84.3)	ASTM D975 NO. 1						
			ASTM D975 NO. 2						
Fitting (Grease nipple)	Grease	As required	NLGI NO. 1						
			NLGI NO. 2						
Radiator	Mixture of antifreeze and water 50 : 50	35(9.2)	Ethylene glycol base permanent type						