

GROUP 4 DISASSEMBLY AND ASSEMBLY

1. MAIN PUMP

1) STRUCTURE

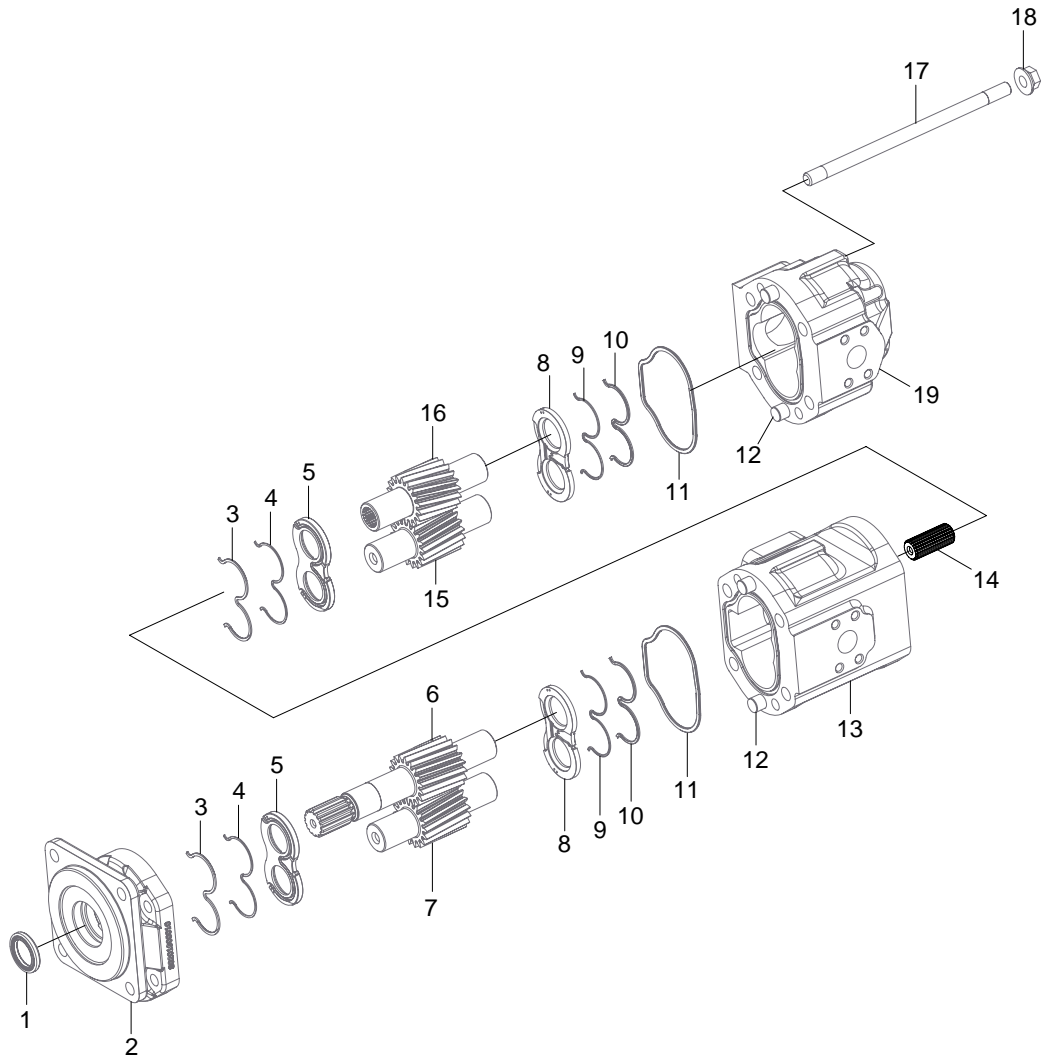

7577WE33

- | | | | | | |
|---|-------------------|----|----------------|----|------------------|
| 1 | Shaft seal | 8 | Wearplate | 14 | Spline coupling |
| 2 | Adapter | 9 | O-ring seal | 15 | Rear driven gear |
| 3 | Back up seal | 10 | Back up seal | 16 | Rear drive gear |
| 4 | O-ring seal | 11 | Interface seal | 17 | Stud |
| 5 | Wearplate | 12 | Dowel | 18 | Flanged nut |
| 6 | Front drive gear | 13 | Front body | 19 | Rear body |
| 7 | Front driven gear | | | | |

2) DISASSEMBLY

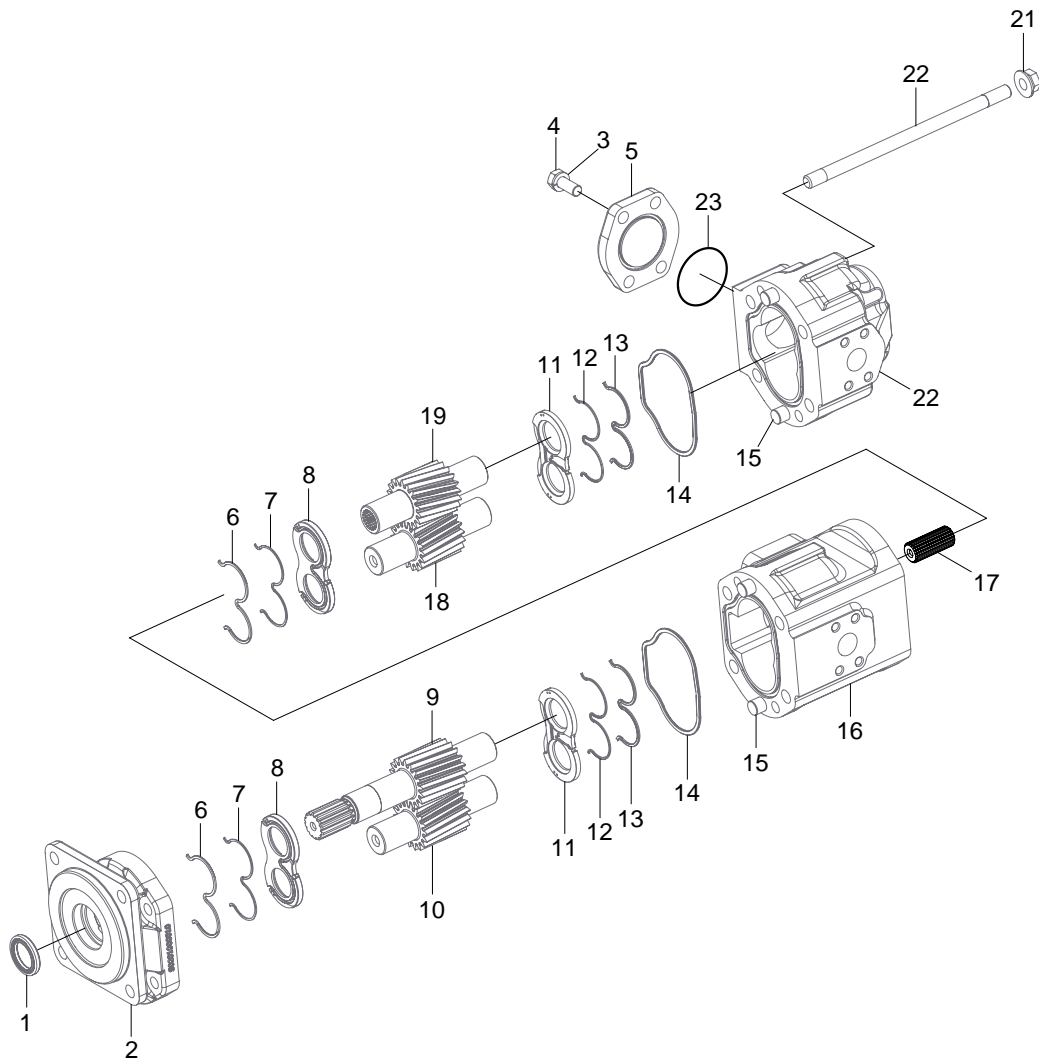

7607WE33

Plug all ports prior to cleaning and disassembling pump to prevent ingress of debris or contamination.

Clean the pump thoroughly with a solvent, ensuring no loose debris or contamination remains on the unit.

Mark each interface and then separate into individual pump sections.

- (1) Securely clamp pump horizontally on one port face, ensuring that no damage is sustained to the port face and remove the stud(17) and nut(18).
- (2) Remove the front adaptor(2) from the body(13) using a pulling tool centred on the drive shaft(6).
Under **NO** circumstances attempt to prise or chisel cover from body as such action could damage the machined sealing faces.
- (3) Remove and discard the shaft seal(1) from adaptor making sure that no damage is sustained to the surface of the seal bore.
- (4) Unclamp pump and place it vertically with drive shaft up.
- (5) Before removing wearplate from the body mark it using a soft pencil or a felt-tip pen to ensure correct reassembly. Remove wearplate(5) complete with O-ring seal(4) and back up seal(6).

DISASSEMBLY

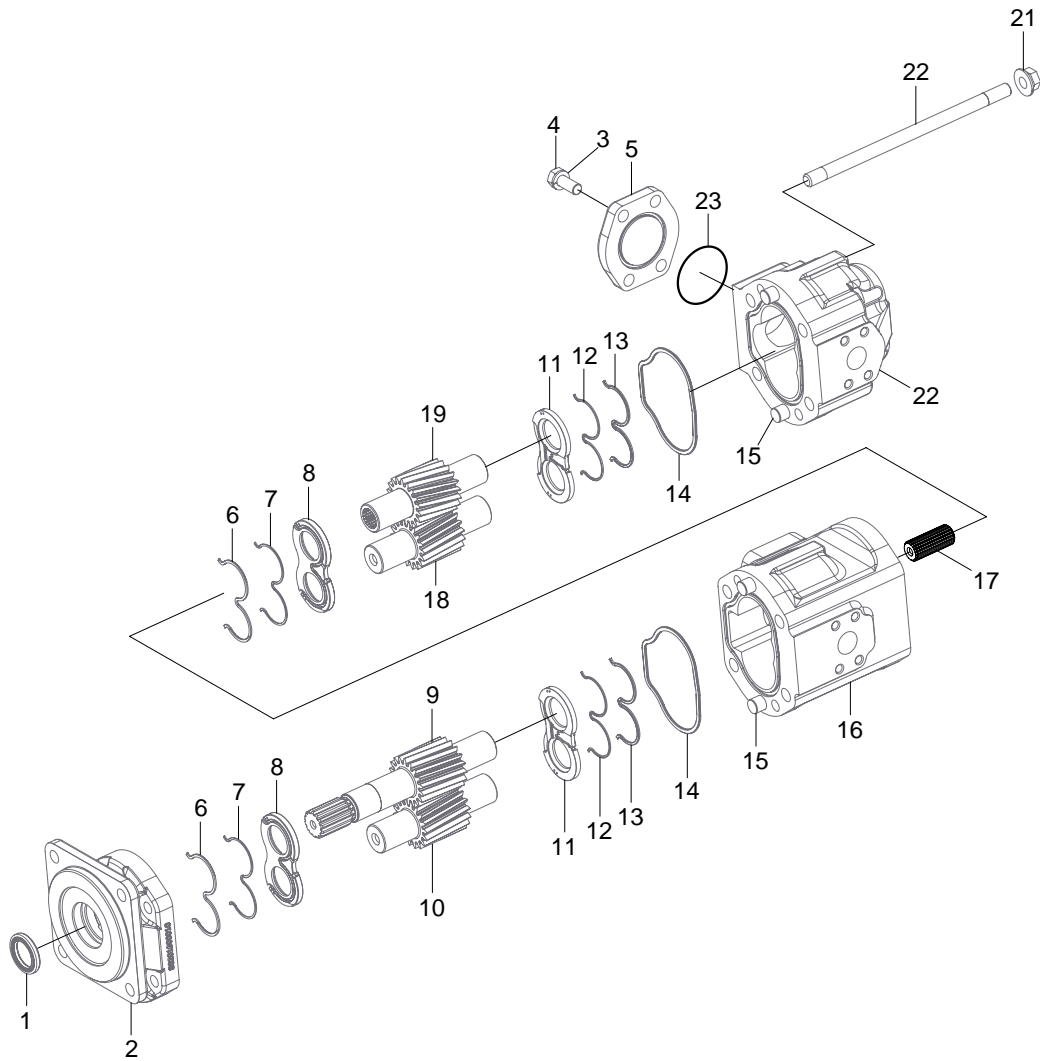

7607WE33

- (6) Mark the gears using a soft pencil or felt-tip pen to ensure assembly in the same relative position, see figure on the right, then withdraw the drive shaft/gear(6) and driven gear(7) separately to prevent jamming.
- (7) Again, to ensure correct assembly, mark remaining wearplate(8) using a soft pencil or a felt-tip pen. Remove wearplate from body complete with O-ring seal(9) and back up seal(10).
- (8) Discard interface seal(11).
- (9) Having separated into individual pumps, proceed as per paragraph (1)~(4).

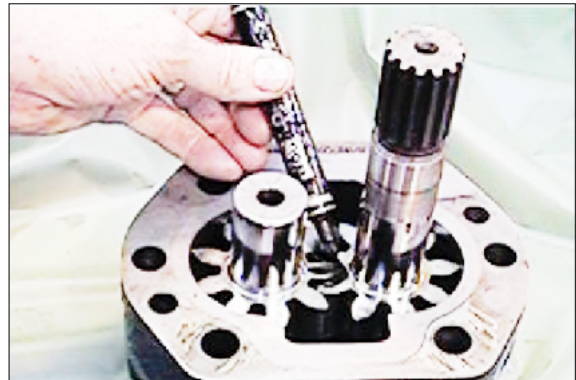

7607WE34

3) MANDATORY REPLACEMENT PARTS

Discard all seals including interface seals, shaft seals, wear plate seals and back up seals. Fit new seals on reassembly. Wearplates should also be replaced with new items from seal kit.

4) HANDLING/STORAGE

While disassembling pump, ensure no surfaces are scored or marked in any way. A rubber surfaced table will be beneficial. All components must be placed in a clean, dry and safe area. Leakage will be created by scratches on components. If parts are to be left for any period ensure they are not exposed to dirt, dust and corrosion. Keep gears separate from each other in protective boxes.

5) INSPECTION OF PARTS

Wash all parts in a solvent and dry.

(1) Adaptor housing and cover

The pump must be replaced if the damage listed is present.

Feature	Damage
Surfaces	Corrosion, nicks or burrs(slight burrs can be removed using and india stone)
Machined sealing Interfaces	Scores, cracks or corrosion
Bearing	Loose

(2) Gears

The pump must be replaced if the damage listed is present.

Feature	Damage
Surfaces	Corrosion, nicks or burrs(slight burrs can be removed using an India stone). Wear due to seal(s)
Journals	Pitting, wear, sufficient wear to change outside diameter
Tooth	Cracks or heavy scoring or chipped
Splines/keyways	Distortion of wear
End faces	Wear, cracks

(3) Floating wear plates

The pump must be replaced if the damage listed is present.

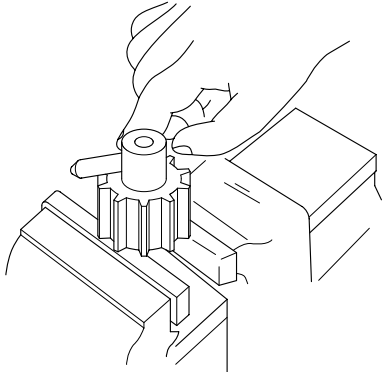
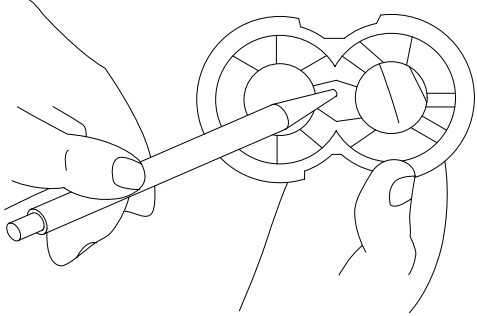
Feature	Damage
Surfaces	Corrosion, nicks or burrs, amounts of scoring, erosion or any cracks, discoloration caused by overheating
 <p>Removing burrs or minor scoring from end faces and teeth of the gears.</p>	 <p>Scoring of wear plate.</p>

(4) Bolts/Studs

The pump should be replaced if the damage listed is present.

Feature	Damage
Surfaces	Corrosion, nicks or burrs (slight burrs can be removed using an India stone), cracks or scoring, distortion or damage to thread form

(5) Plain bearings

The pump must be replaced if the damage listed is present.

Feature	Damage
Surfaces	Cracks or scoring
PTEF Coating	Worn-bronze, sub-layer showing
Bearing	Loose in housing/cover

(6) Coupling

This must be replaced if damage listed is present.

Feature	Damage
Surfaces	Corrosion, nicks or burrs, erosion, cracks or pitting
Splines	Distorted or badly worn

6) ASSEMBLY

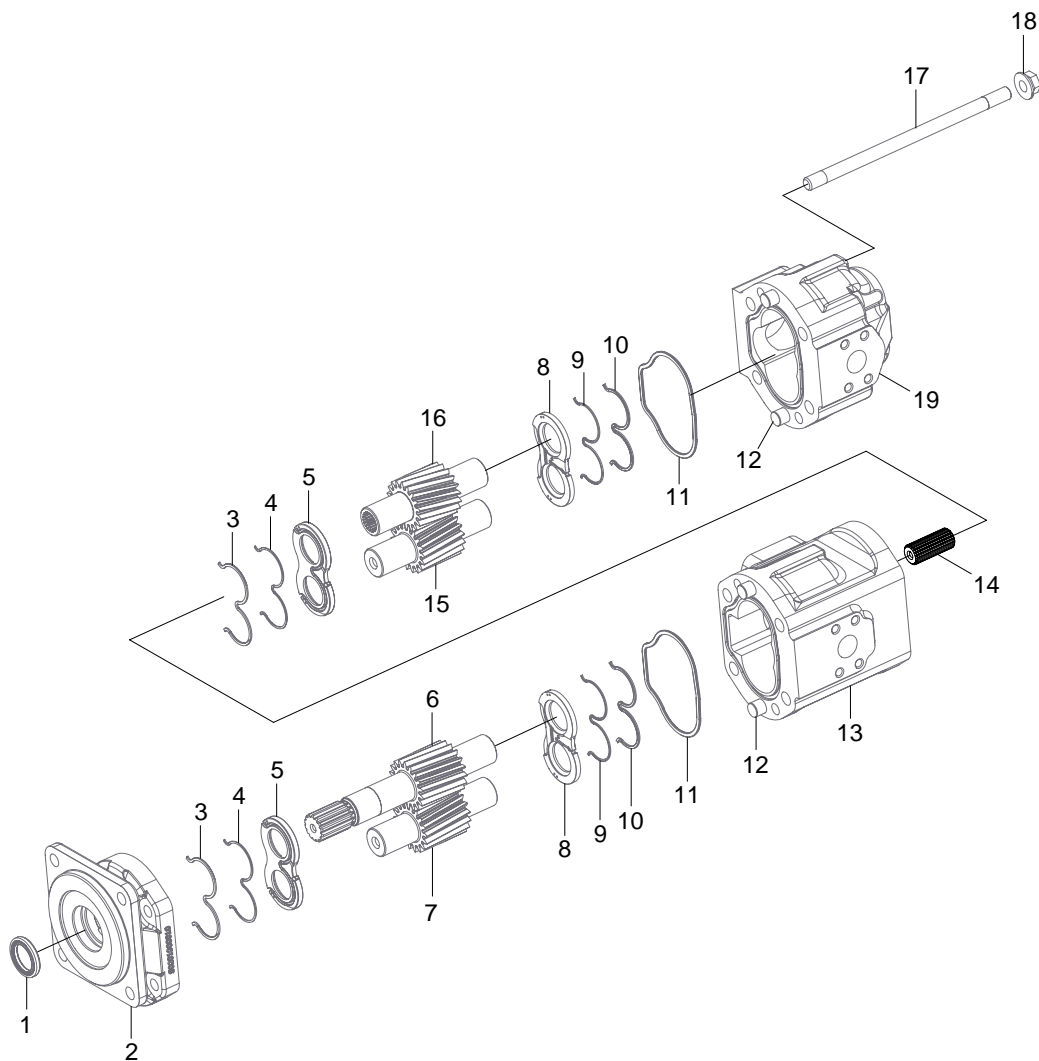

7577WE33

It is critical that the wearplates are assembled into the pump with regard to the following:

- The seal side of the wearplate must be adjacent to the adaptor or body.
- The high pressure side of the wearplate must be adjacent to the outlet port.

This must take place in a clean dry area, ensuring that all parts are clean and free from contamination or loose particles. Lightly oil all surfaces.

- (1) Place body vertically with gear pockets upper most.
- (2) Slide wearplate(8) complete with O-ring seal(9) and back up seal(10) down through the housing to the bottom of the gear pockets.

Be sure to refit the wearplate the same as that marked from this position during disassembly.

- (3) Fit the gears(15,16) within the housing taking care to replace as marked, with the teeth reassembled to their original related position.
- (4) Fit the wearplate(5) complete with O-ring seal(4) and back up seal(3).

Be sure to refit the wearplate the same as that marked from this position during disassembly.

ASSEMBLY

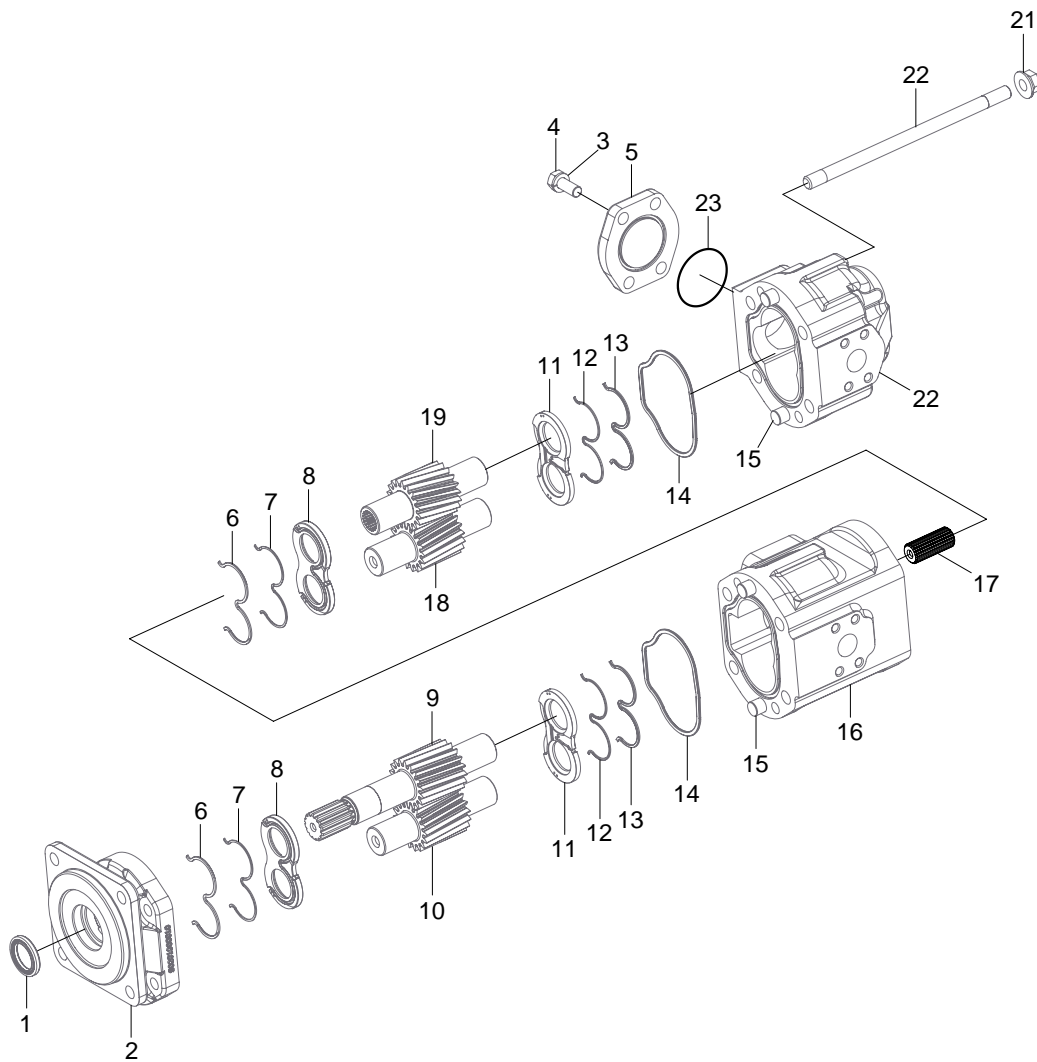

7607WE33

- (5) Fit new interface seal(11) into groove in body.
- (6) Proceed as per paragraph(1)~(2).
- (7) Fit adaptor(2) over the drive gear(6) and fit stud(17).
- (8) Securely clamp unit and tighten nut(18) to half torque and then full torque.
 - Tightening torque : 23.2kgf · m(168lbf · ft)
- (9) Fit shaft seal(1) using appropriate tooling, in correct position and orientation.
- (10) Pour a little clean hydraulic oil into the ports.

2. MAIN CONTROL VALVE

1) STRUCTURE

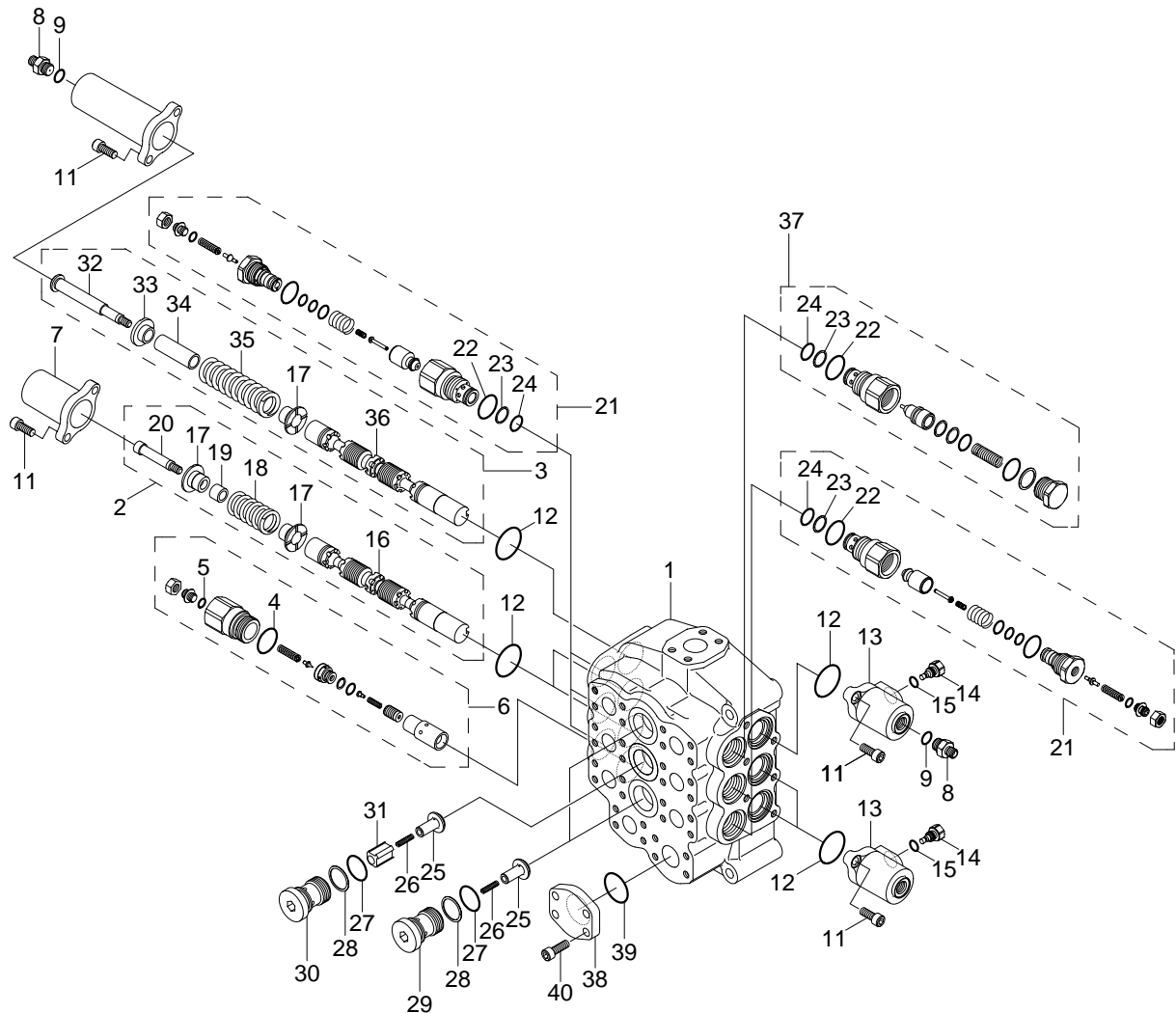

7607WE35

1	Housing assembly	15	O-ring	28	Back up ring
2	Plunger assembly	16	Plunger	29	Cap
3	Plunger assembly	17	Guide	30	Cap
4	O-ring	18	Spring	31	Check
5	O-ring	19	Spacer	32	Cap
6	Main relief assembly	20	Nipple	33	Guide
7	Cover	21	Port relief assembly	34	Spacer
8	Nipple	22	O-ring	35	Spring
9	O-ring	23	Back up ring	36	Plunger
10	Cover	24	O-ring	37	Make up assembly
11	Socket bolt	25	Check	38	Cover
12	O-ring	26	Spring	39	O-ring
13	Cover	27	O-ring	40	Bolt
14	Plug				

2) GENERAL PRECAUTIONS

- (1) Clean room with no dust is recommended for maintenance. Because hydraulic components are precision, and have minute clearance. Tool and wash-oil must be clean, too. Handle them carefully.
- (2) At removing control valve from the machine, wash around the piping port, and neither dust nor water should go into inside with plugging. It is same at attaching the machine.
- (3) Prepare the required parts by checking structure figure before assembly. There are parts which are supplied with only sub-assembly part, so check the parts list before assembly.

3) PRECAUTIONS FOR DISASSEMBLY

- (1) Handle the components carefully not to drop them or bump them with each other as they are made with precision.
- (2) Do not force the work by hitting or twisting as burred or damaged component may not be assembled or result in oil leakage or low performance.
- (3) When disassembled, tag the components for identification so that they can be reassembled correctly.
- (4) Once disassembled, O-ring and back-up rings are usually not to be used again. (Remove them using a wire with its end made like a shoe-horn. Be careful not to damage the slot)
- (5) If the components are left disassembled or half-disassembled, they may get rust from moisture or dust. If the work has to be interrupted, take care to prevent rust and dust.

4) PRECAUTIONS FOR REASSEMBLY

- (1) Take the same precautions as for disassembly.
- (2) When assembling the components, remove any metal chips or foreign objects and check them for any burrs or dents. Remove burrs and dents with oil-stone, if any.
- (3) O-rings and back-up rings are to be replaced with new ones, as a rule.
- (4) When installing O-rings and back-up rings, be careful not to damage them. (Apply a little amount of grease for smoothness)
- (5) Tighten the bolts and caps with specified torque.

5) SPECIAL TOOL

· HOLDER

Material : copper

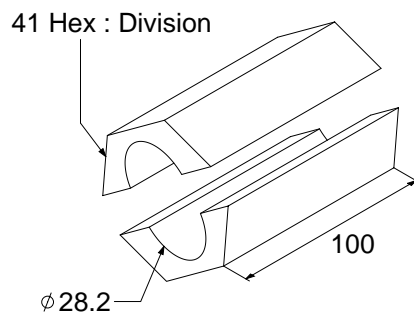

Regarding to change the main plunger

We can not supply the main plunger, because the plunger is fit for valve housing.

So, do not change the plunger at the field. If changing plunger must be needed, then tell us model name of control valve and serial number written at its nameplate.

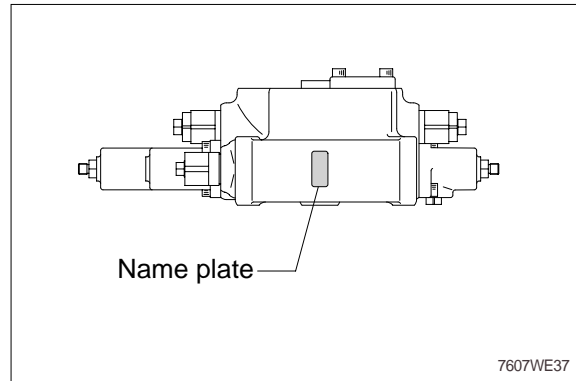

6) BUCKET PLUNGER AND ACCESSORY PLUNGER

Reassemble in the opposite order to disassemble.

To reassemble correctly, attach an identification tag immediately after parts are removed.

- (1) Remove hexagon socket bolts(1) then remove cover(2).

- Hexagon socket bolt
Width across flat : 8mm
Tightening torque : 5.1kgf · m(36.8lbf · ft)

Reassembly

Install cover(2), after making sure that O-ring is placed on the edge of the housing hole.

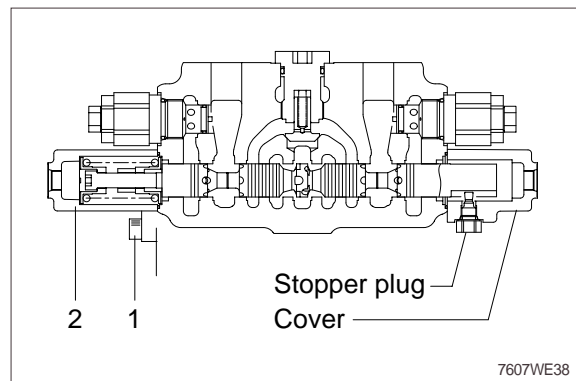

- (2) Pull out spool assembly from housing.

Do not pull out the spool all at once. Pull slowly while fitting in the housing hole.

Reassembly

Set the key groove of the plunger with the stopper plug of the cover.

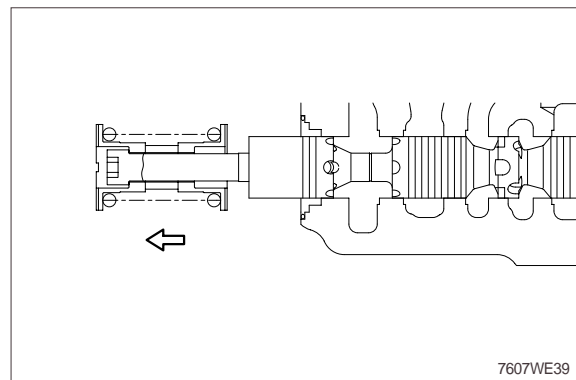

- (3) Set the spool between holders and loosen plunger cap(3) by using vise.

- Plunger cap
Width across flat : 8mm
Tightening torque : 6.1kgf · m(44.2lbf · ft)

Set the spool between holders and clamp them by a vise after degreasing the spool and holders as a special tool.

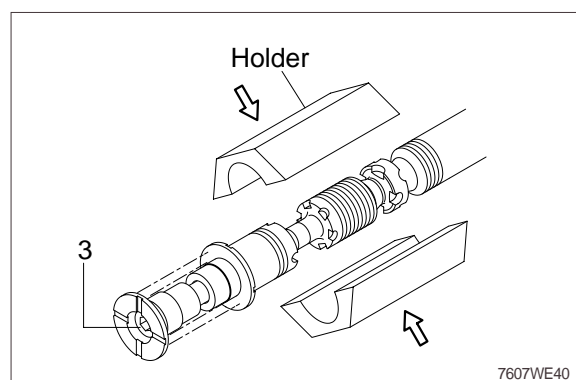

- (4) Remove the plunger cap(3), spring guide (4), spring(5) and sleeve(6).

Spring is different from boom section spring.

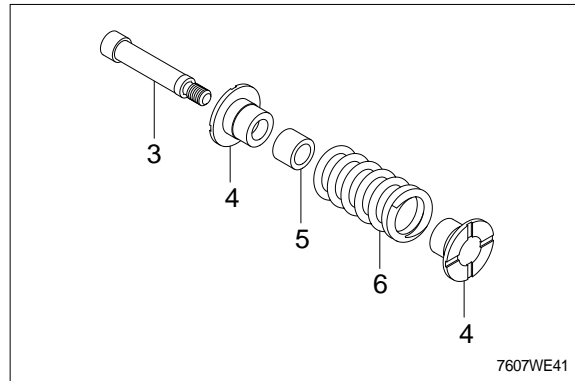

- (5) Remove hexagon socket bolts(8) then remove cover(9) after remove plug(7).

· Plug(7)

Width across flat : 19mm

Tightening torque : 8.2kgf · m(59.0lbf · ft)

· Hexagon socket bolt(8)

Width across flat : 8mm

Tightening torque : 5.1kgf · m(36.8lbf · ft)

Make sure that O-ring is on the face of housing.

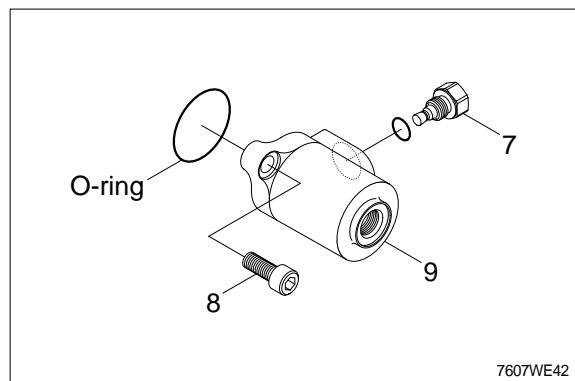

7) BOOM PLUNGER

- (1) Remove hexagon socket bolts(1) then remove cover(2).

· Hexagon socket bolt

Width across flat : 8mm

Tightening torque : 5.1kgf · m(36.8lbf · ft)

Reassembly

Install cover(2), after making sure that O-ring is placed on the edge of the housing hole.

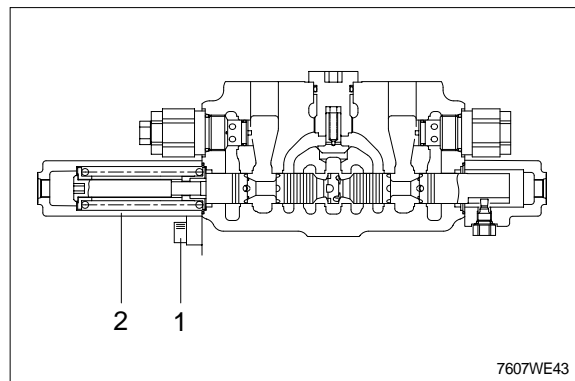

- (2) Pull out spool assembly from housing.

Do not pull out the spool all at once.

Pull slowly while fitting in the housing hole.

Reassembly

Set the key way of the plunger to the stopper plug of the cover.

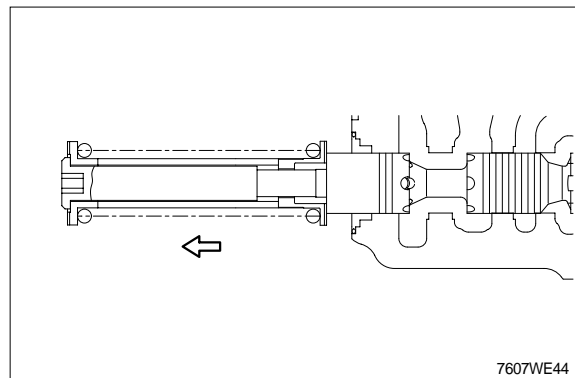

(3) Set the spool between holders and loosen plunger cap(3) by using vise.

- Plunger cap
- Width across flat : 8mm
- Tightening torque : 6.1kgf · m(44.2lbf · ft)

Set the spool between holders and clamp them by a vise after degreasing the spool and holders as a special tool.

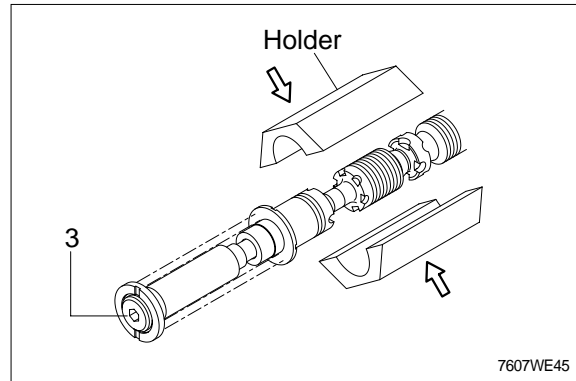

(4) Remove the plunger cap(3), spring guide (4), spring(5), sleeve(6) and spring guide (7).

Spring is different from the other section spring.

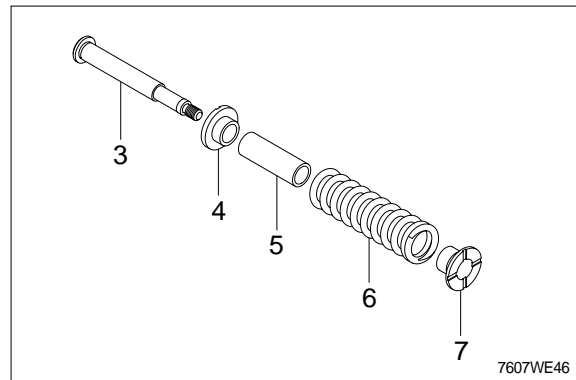

(5) Remove hexagon socket bolts(8) then remove cover(9) after remove plug(7).

- Plug(7)
- Width across flat : 19mm
- Tightening torque : 8.2kgf · m(59.0lbf · ft)
- Hexagon socket bolt(8)
- Width across flat : 8mm
- Tightening torque : 5.1kgf · m(36.8lbf · ft)

Confirm that O-ring is put to end face of housing.

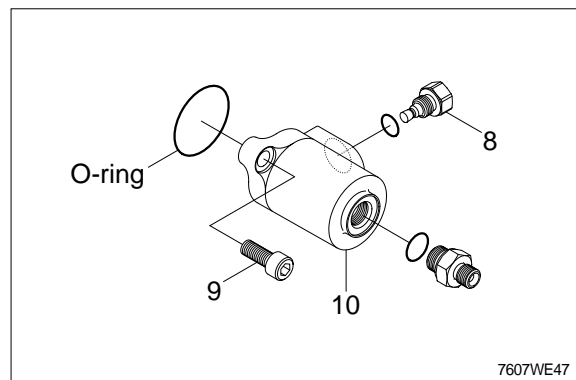

8) MAIN RELIEF VALVE

(1) Loosen cap(1) and remove the main relief cartridge from the body.

- Cap(1)
- Width across flat : 41mm
- Tightening torque : 10.2kgf · m(73.8lbf · ft)

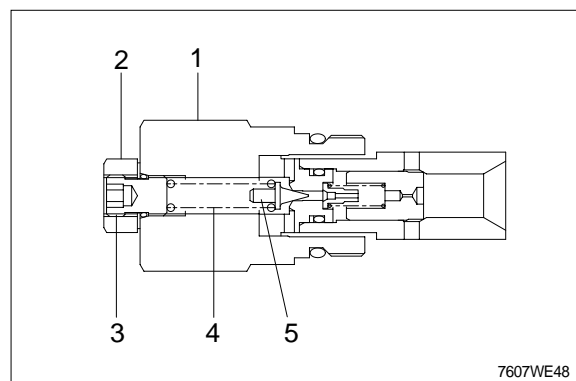

(2) Loosen hex nut(2), and remove adjust screw(3), spring(4) and pilot poppet(5).

- Hex nut(2)
Width across flat : 19mm
Tightening torque : 3.3kgf · m(23.6lbf · ft)
- Adjust screw(3)
Width across flat : 22mm

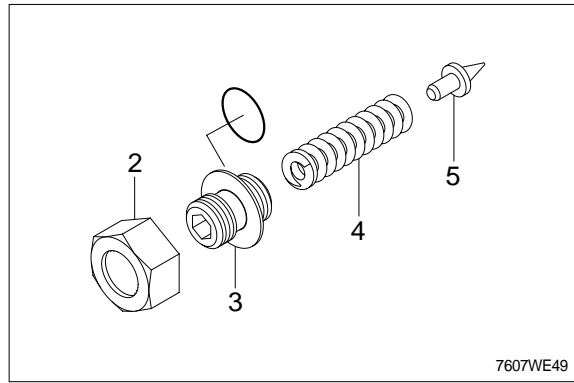

(3) Pull out sleeve(9), and remove orifice(6), spring(7) and main poppet(8).

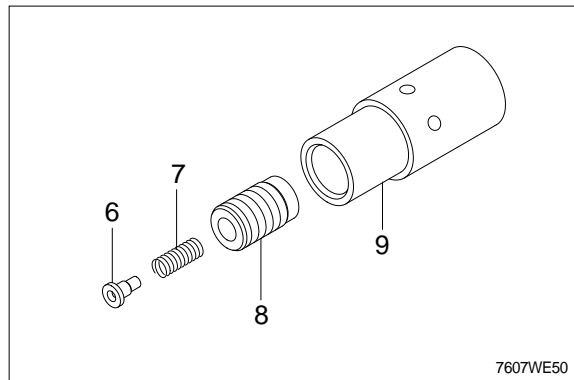

Do not disassemble pilot seat, because the pilot seat is assembled with pressure.

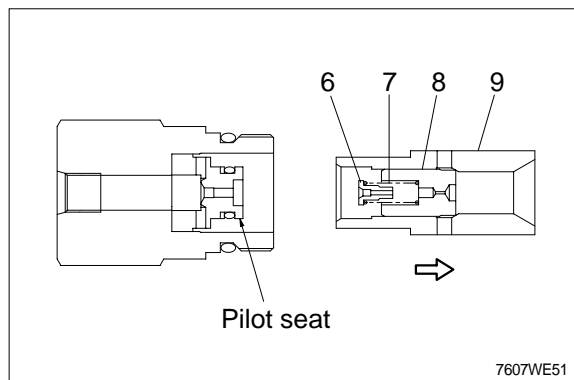

(5) RESETTING THE RELIEF PRESSURE

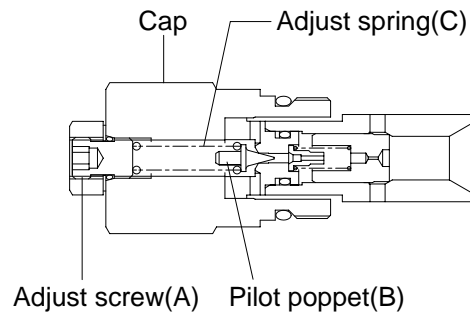

7607WE52

If setting pressure is mistaken, hydraulic unit may be destroyed and danger may be caused. Do not raise by any means more than the pressure decided for every model.

Temporary assembly and setting

Check the position of setting pressure 0 MPa.

Set adjusting screw(A) temporarily in the position that pilot poppet(B) contacts to pilot seat.

Then pressure adjusting spring(C) begins to be effective.

Install the main relief valve which is set temporarily to main body.

Tighten cap with torque wrench.

- Tightning torque : 10.2kgf · m(73.8lb · ft)

To set pressure

Attach exact pressure gauge at exit of pump or gauge port of control valve.

Operate the pump with rated speed.

Operate plunger either boom or bucket at full stroke and check the pressure.

Turn adjusting screw(A) (right turn) and set pressure with checking pressure gauge.

- One quarter turn of adjusting screw(A) equals about 4 MPa.
- Setting pressure 20.6MPa(210kgf/cm²) at 220 /min.
- Relief is very sensitivity. So, do not turn adjusting screw(A) suddenly.

Tighten lock nut with torque wrench holding adjusting screw.

- Tightning torque : 3.3kgf · m(23.6lb · ft)

Operate plunger and check the setting pressure, again.

9) PORT RELIEF VALVE

Do not disassemble adjusting screw.
It's impossible to readjust setting pressure exactly on the machine.

(1) Loosen sleeve(1) and remove relief valve.

- Sleeve(1)
Width across flat : 41mm
Tightening torque : 10.2kgf · m(73.8lbf · ft)

Install to original position.

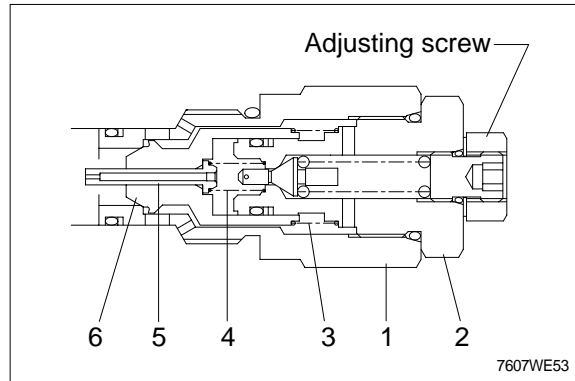

(2) Loosen and remove relief seat sub-assembly(2). And remove spring(3),(4) piston(5), and main poppet(6).

- Relief seat(2)
Width across flat : 36mm
Tightening torque : 10.2kgf · m(73.8lbf · ft)

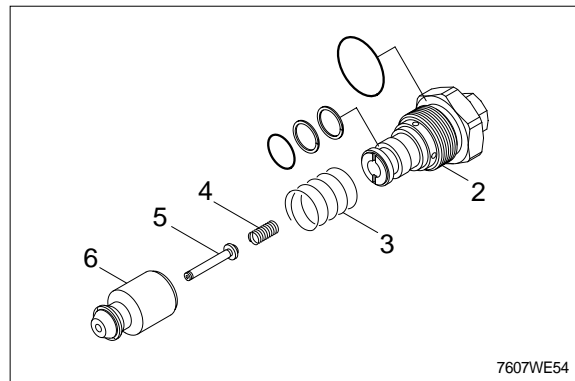

10) MAKE UP VALVE

(1) Loosen sleeve(1) and remove relief valve.

- Sleeve(1)
Width across flat : 41mm
Tightening torque : 10.2kgf · m(73.8lbf · ft)

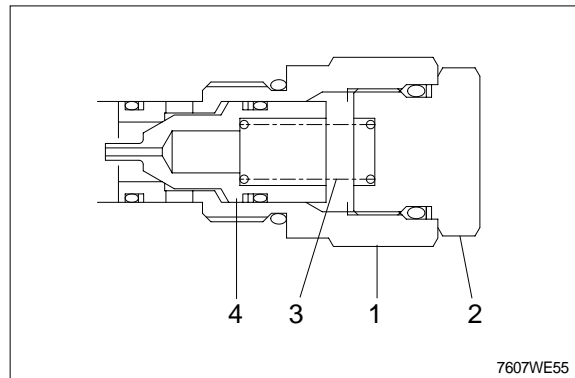

(2) Remove cap(2) and pull out spring(3), poppet(4).

- Cap(2)
Width across flat : 36mm
Tightening torque : 10.2kgf · m(73.8lbf · ft)

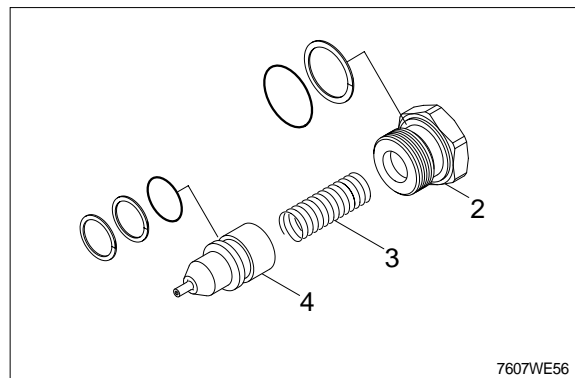

11) LOAD CHECK VALVE

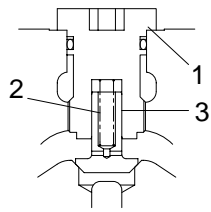

- Bucket for 2-spools valve
- Aux for 3-spools valve
- Boom for 2 & 3-spools valve

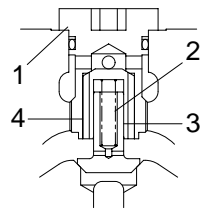

- Bucket for 3-spools valve

7607WE57

Example for explanation : Bucket section of 3-spools valve(double check)

(1) Remove cap(1) pull out spring(2), check (3) and (4)

· Cap(2)

Width across flat : 36mm

Tightening torque : 25.5kgf · m(184lbf · ft)

When reassembly ;

Be careful for the back-up ring not to protrude.

Only Bucket section has double check.

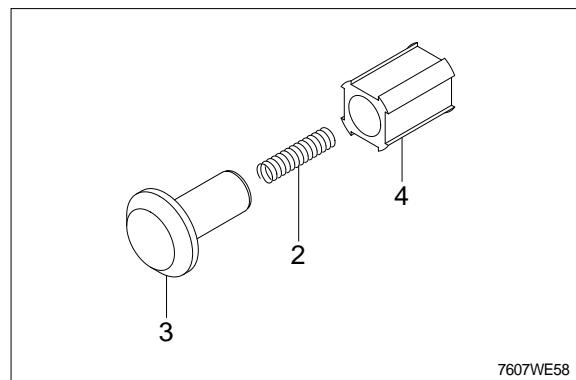

3. REMOTE CONTROL VALVE

1) STRUCTURE

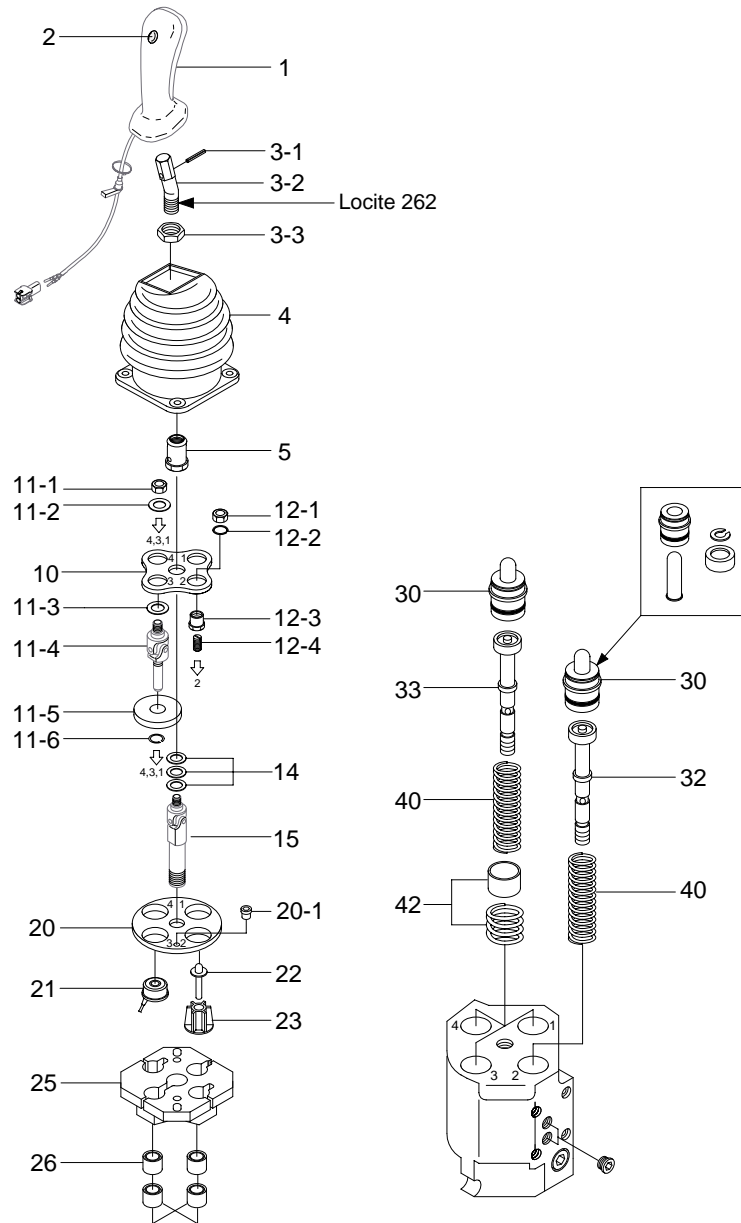

7707WE64

- | | | | | | |
|------|------------------|------|------------------------|----|----------------------------|
| 1 | Handle | 11-4 | Cardan | 21 | Solenoid |
| 2 | Push button | 11-5 | Armature | 22 | Intermediary plunger kit |
| 3-1 | Locking pin | 11-6 | Spring ring | 23 | Intermediary plunger guide |
| 3-2 | Bent lever | 12-1 | Counter nut | 25 | Electric bracket |
| 3-3 | Nut | 12-2 | Spring ring | 26 | Bushing |
| 4 | Rubber boot | 12-3 | Switch plate screw | 30 | Plunger kit |
| 5 | Locking nut | 12-4 | Press screw | 32 | Regulation unit |
| 10 | Cardan bracket | 14 | Shims(0.1, 0.2, 0.5mm) | 33 | Regulation unit |
| 11-1 | Self-locking nut | 15 | Cardan | 40 | Return spring |
| 11-2 | Washer | 20 | Flange | 42 | Prefeeling point kit |
| 11-3 | Washer | | | | |

2) DISASSEMBLY AND ASSEMBLY

(1) PUSH BUTTEN

- ※ The remote control valve does not need to be removed from the machine to perform this operation.
Remove worn pushbutton using a small screwdriver.
The installation of new elements is performed without any special tools; the parts are simply pressed into place.

(2) RUBBER BOOT

Remove the remote control valve from the machine or free the valve by unscrewing the 4 screws fixing the plate in order to release the electrical cable.

- Assembly

Torque : 1.02kgf · m(7.4lbf · ft)

Hold the remote control valve using a vice or a vice-grip wrench(clamp onto the body).

The pilot unit does not need to be removed from the machine to release the cable. However, it is recommended to lift the control unit by undoing the 4 fixing screws on the arm rest.

It is unnecessary to remove the units with no electrical functions.

Lift and turn the boot inside out.

Remove the grommet(7) from its emplacement to free the cable.

Loosen the handle mounting nut(3-3) using a 19mm open-end wrench.

- Assembly : torque 4.08kgf · m(29.5lbf · ft)

Unscrew and remove the handle(1).

- Assembly

- Add loctite 262 onto the lever thread

- Torque : 4.08kgf · m(29.5lbf · ft)

Replace the faulty rubber boot(4) with a new one.

Replace the handle(1) following the disassembly instructions in reverse order.

(3) HANDLE

Clamp the threaded section of the lever(3-2) in a vice fitted with V-shaped vice clamp.

Remove the pin(3-1) using a 5mm pin driver.

Replace the lever(3-2) onto the new handle(1) and secure it with the pin(3-1) using a 5mm pin driver.

Respect the position of the curved lever to ensure that the handle is correctly oriented as indicated by the machine's technical specifications.

Replace the nut(3-3) on the threaded section and replace the boot(4).

(4) DETENT CARDAN BRACKET KIT

Remove the 2 grommets(20-1) from the flange (20).

Place centering sleeves V & W to avoid damaging the cardan knuckles while loosening the nuts.

Unscrew the locking nut(5) using a 23mm open-end wrench.

- Assembly : Torque $4.08 \pm 0.4\text{kgf} \cdot \text{m}$
($29.5 \pm 2.9\text{lbf} \cdot \text{ft}$)

Unscrew the self-locking nut(11-1) using a 13mm open-end wrench.

- Assembly
 - Torque $1.02\text{kgf} \cdot \text{m}$ ($7.4\text{lbf} \cdot \text{ft}$)
 - Place centering sleeves(V-W) to avoid damaging the cardan knuckles while screwing the nuts.

- Remove :
- Friction washer(11-2)
 - Friction washer(11-3)
 - Cardan/armature assembly (11-4 ~ 11-6)

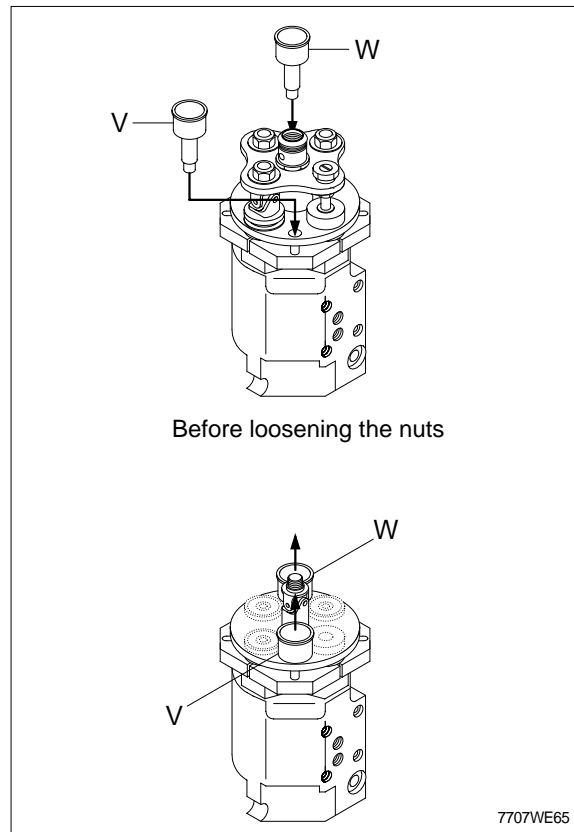

(5) NON-DETENT PLUNGER KIT

Unscrew the self-locking nut(12-1) using a 13mm open-end wrench.

- Reassembly : - Torque $1.02\text{kgf} \cdot \text{m}$ ($7.4\text{lbf} \cdot \text{ft}$)
 - Place centering sleeves(V-W) to avoid damaging the cardan knuckles while screwing the nuts.

Undo the snap ring(12-2) using a flat-end screwdriver.

Remove the screw assembly(12-3, 12-4)

(6) CARDAN

Remove the centering sleeves **V** & **W**.

Remove the cardan bracket(10) and the shims(14).

Unscrew the cardan(15) using a 17mm open-end wrench.

- Reassembly : - Ungrease the cardan threads
 - Add loctite 262 onto the cardan threads(both end)
 - Torque $4.08\text{kgf} \cdot \text{m}$ ($29.5\text{lbf} \cdot \text{ft}$)

(7) SOLENOID AND CONNECTOR

It is advised to mount the connector onto the solenoid cable once the remote control valve is assembled.

Remove the flange(20) and the electrical bracket(25),

Remove the protecting bushes(26) from the electrical bracket(25).

Undo the solenoid(21) from the electric bracket(25).

Replace the solenoid.

Clean the polar face using a piece of cloth and pay attention not to hit them.

Assembly : Place the solenoid cable in its emplacement on the electric bracket before fitting the protection bushes.

(8) INTERMEDIARY PLUNGER KIT

Undo the intermediary plunger guide(23).

Remove and replace the intermediary plunger kit assembly(22).

(9) GUIDE / PLUNGER AND REGULATION UNIT

Beware of the plungers that might jump out due to the spring return.

Remove : - Guide/plunger assembly(30).

- Regulation unit(32/33).

- Return spring(40).

- Pre-feeling point kit(42).

The remote control valve is now totally disassembled.

Assemble in reverse order following the torque specification.