

GROUP 2 ELECTRICAL CIRCUIT

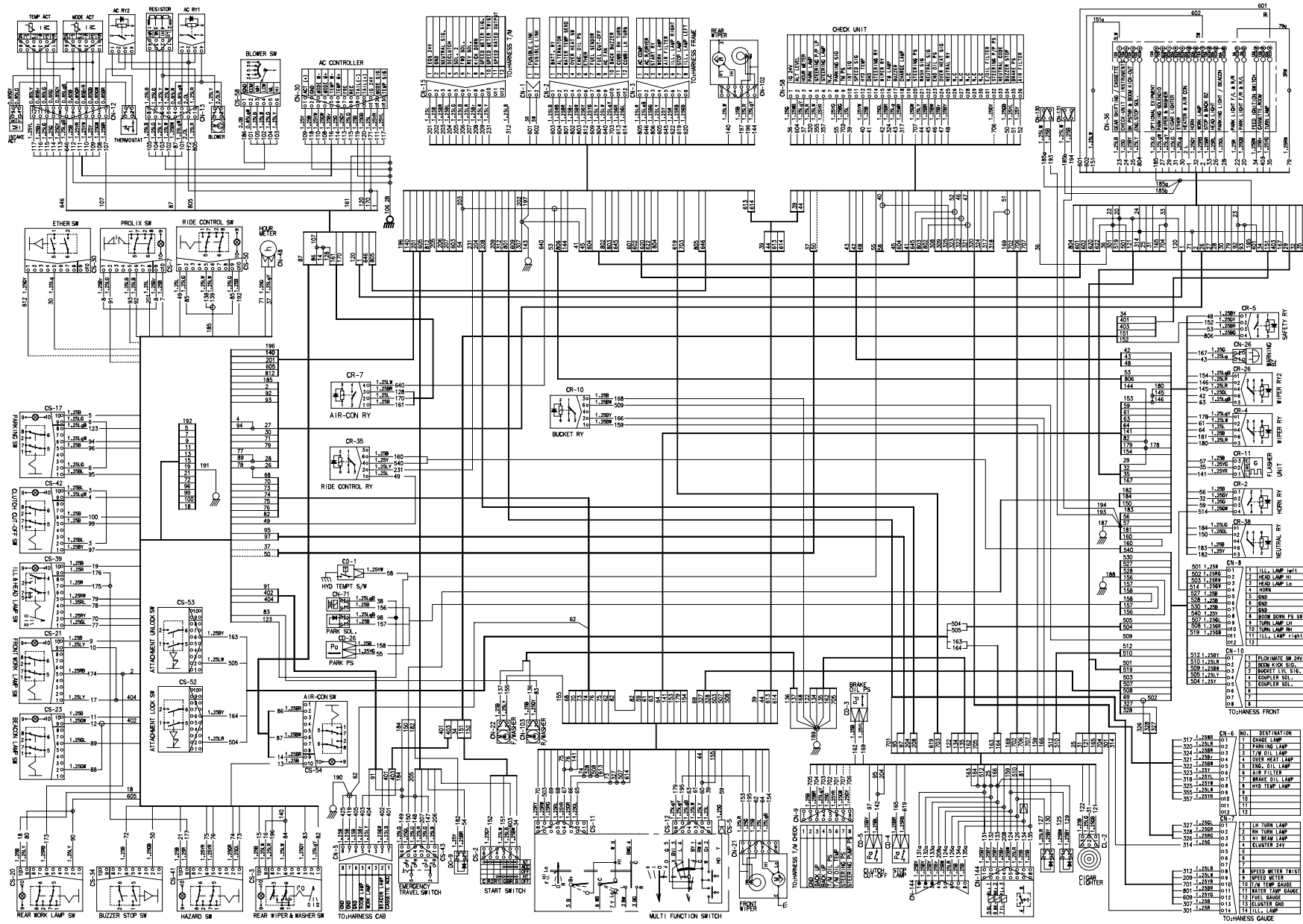

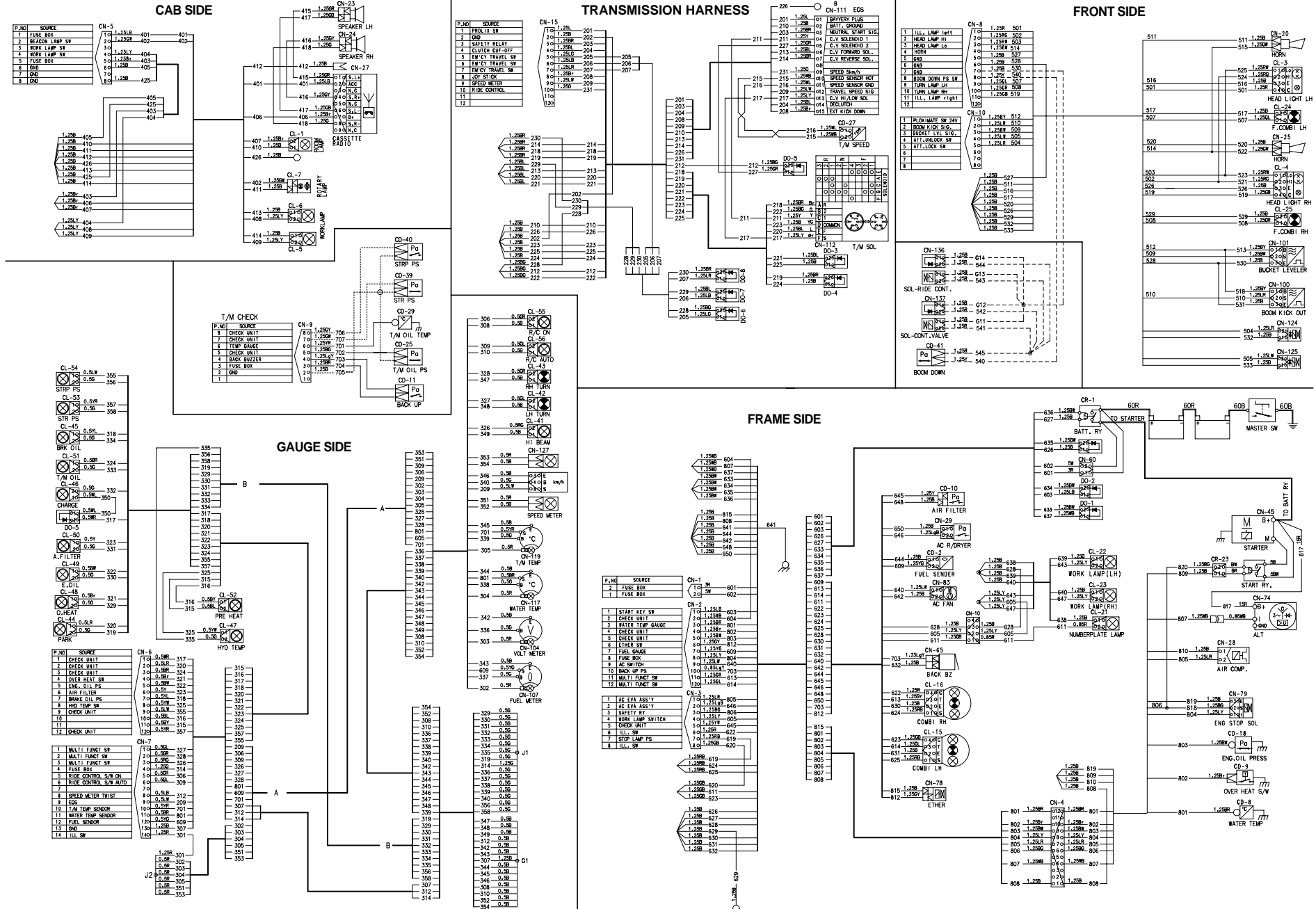

1. ILLUMINATION CIRCUIT

1) OPERATING FLOW

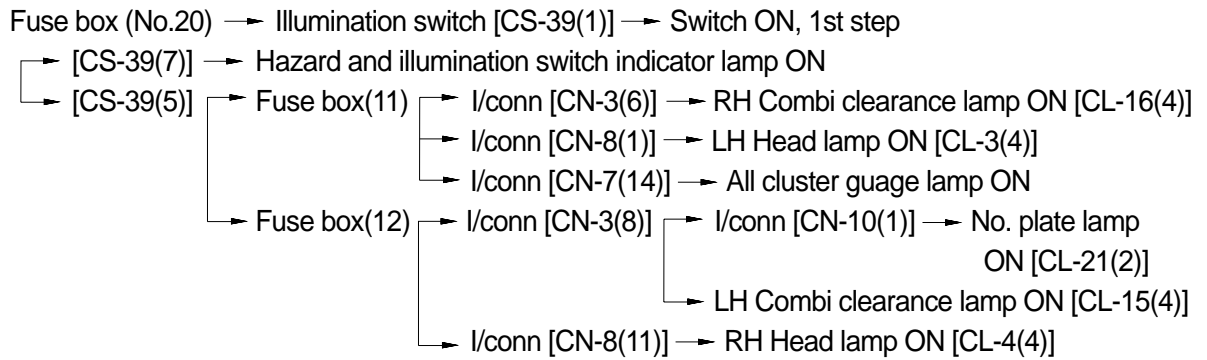

2) CHECK POINT

Engine	Key switch	Check point	Voltage
OFF	ON	① - GND (Switch input) ② - GND (Switch output) ③ - GND (To light) ④ - GND (To gauge lamp)	20~25V

※ GND : Ground

2. HEAD LIGHT CIRCUIT

1) OPERATING FLOW

Fuse box(No.19) → Head light switch [CS-39(4)] → Light switch ON, 2nd step [CS-39(2)]

→ Multi function switch [CS-11(8)]

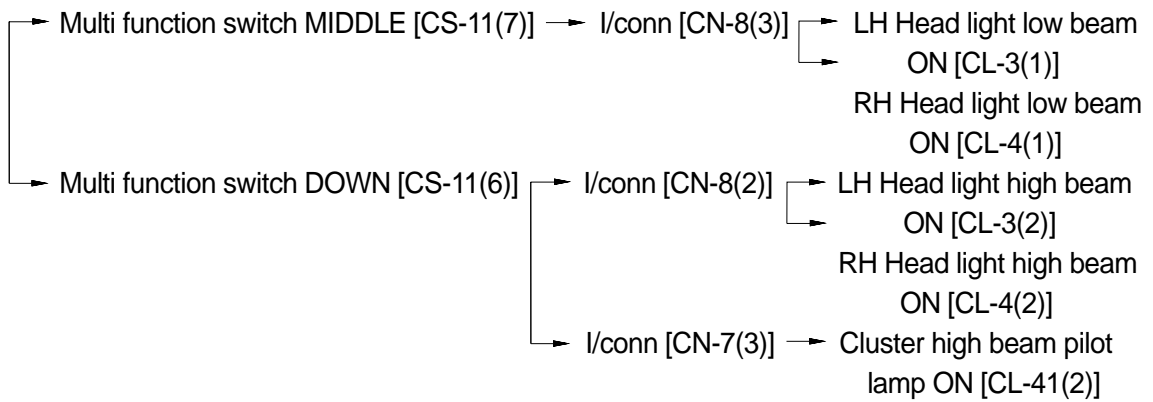

2) CHECK POINT

Engine	Key switch	Check point	Voltage
OFF	ON	① - GND (Switch input) ② - GND (Switch output) ③ - GND (Multi function input) ④ - GND (Multi function output) ⑤ - GND (Multi function output) ⑥ - GND (Low beam) ⑦ - GND (High beam) ⑧ - GND (Passing B+)	20~25V

※ GND : Ground

HEAD LIGHT CIRCUIT

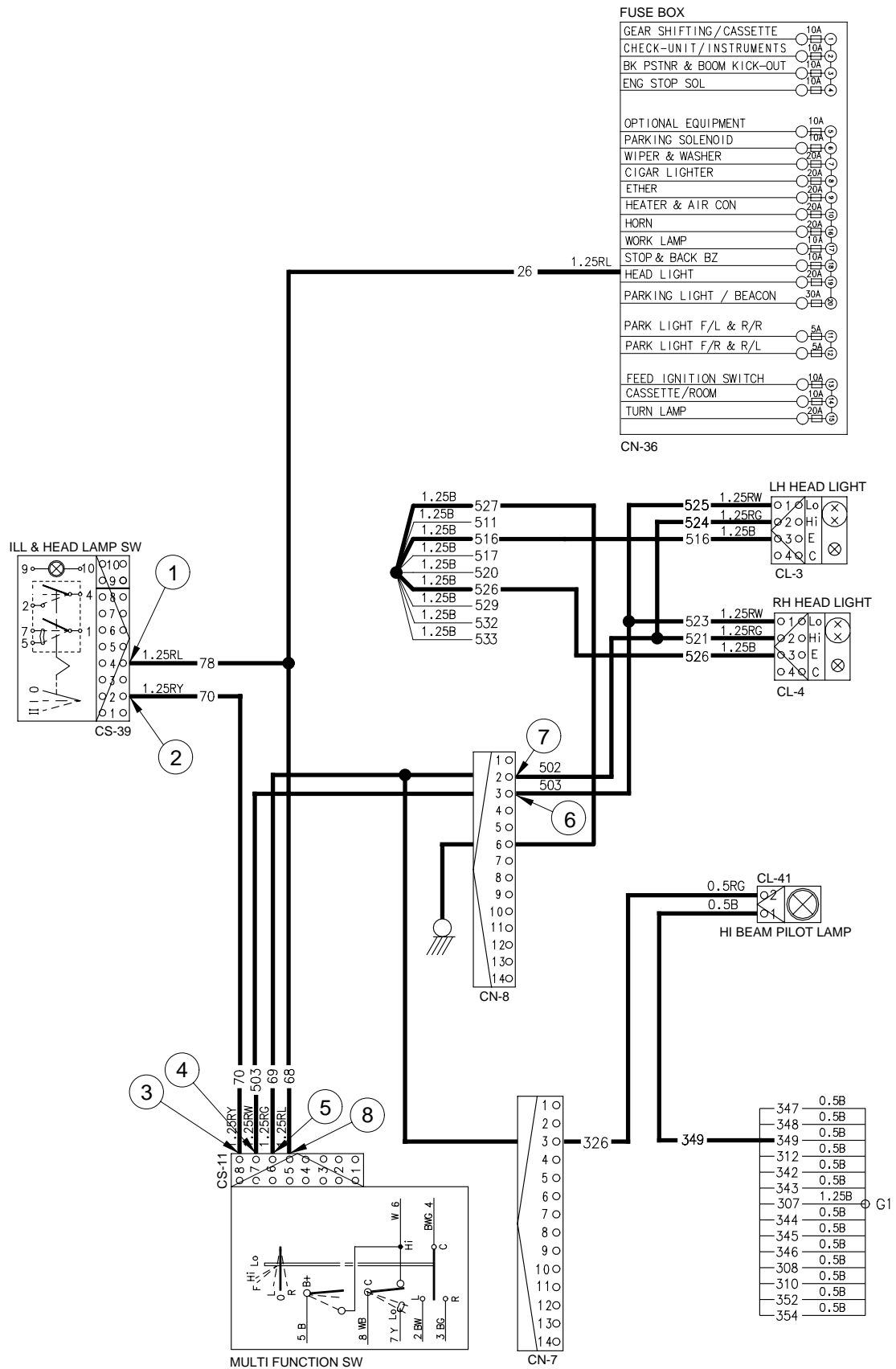

3. WORK LIGHT SWITCH

1) OPERATING FLOW

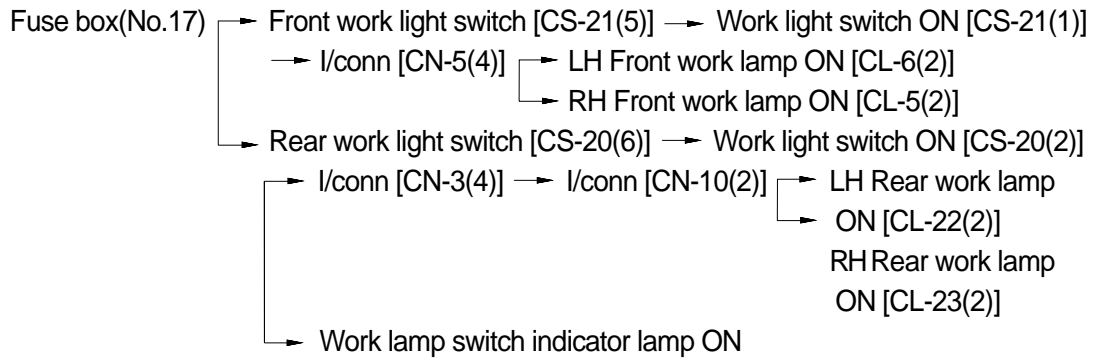

2) CHECK POINT

Engine	Key switch	Check point	Voltage
OFF	ON	① - GND (Switch input) ② - GND (Switch output) ③ - GND (Front work light) ④ - GND (Rear work light)	20~25V

※ GND : Ground

WORK LIGHT SWITCH

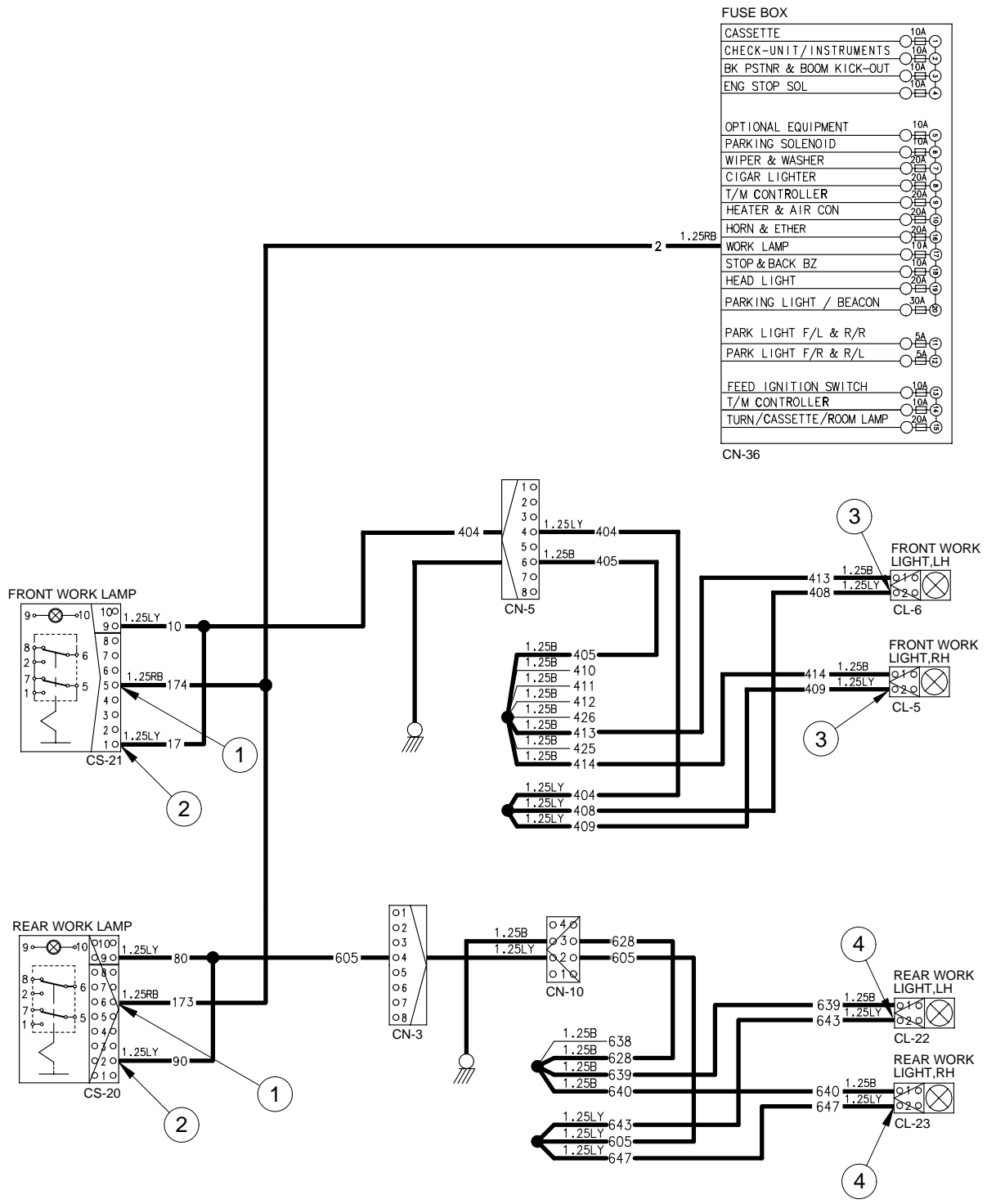

4. STARTING CIRCUIT

1) OPERATING FLOW

Battery(+) terminal → Battery relay(M8, B⁺ terminal) → Fusible link [CN-60(1)]

→ I/conn [CN-1(1)] → Fuse box (No.13) → Start switch [CS-2(1)]

※ The EGS lever is neutral position. It is necessary condition before the starting.

The EGS has an output signal which is activated whenever the shift lever is in the neutral position.

This signal can be used to control a relay and prevent engine from starting whenever the shift lever is not in the neutral position.

(1) When start key switch is in ON position

Start switch ON → Start switch [CS-2(2)] → I/conn [CN-2(1)] → Battery relay [CR-1]
 → Battery relay operating(All power is supplied with the electric component)
 Start switch [CS-2(3)] → Fuse box [No.4] → I/conn [CN-2(8)]
 → I/conn [CN-4(8)] → Engine stop solenoid [CN-79]

(2) When start key switch is in START position

Start switch START [CS-2(5)] → Start safety relay [CR-5(2)] → Start safety relay [CR-5(4)]
 → I/conn [CN-3(3)] → I/conn [CN-4(6)] → Start relay [CR-23(2)]
 → Starter(Terminal B⁺ and M connector of start motor)

2) CHECK POINT

Engine	Key switch	Check point	Voltage
Running	ON	① - GND (Battery B ⁺) ② - GND (Fusible link) ③ - GND (Start key B ⁺) ④ - GND (Start key BR terminal) ⑤ - GND (I/conn CN-2(1)) ⑥ - GND (Start key R2 terminal) ⑦ - GND (Start safety relay output) ⑧ - GND (Check unit) ⑨ - GND (Start key IG terminal) ⑩ - GND (Engine stop solenoid)	20~25V

※ GND : Ground

STARTING CIRCUIT

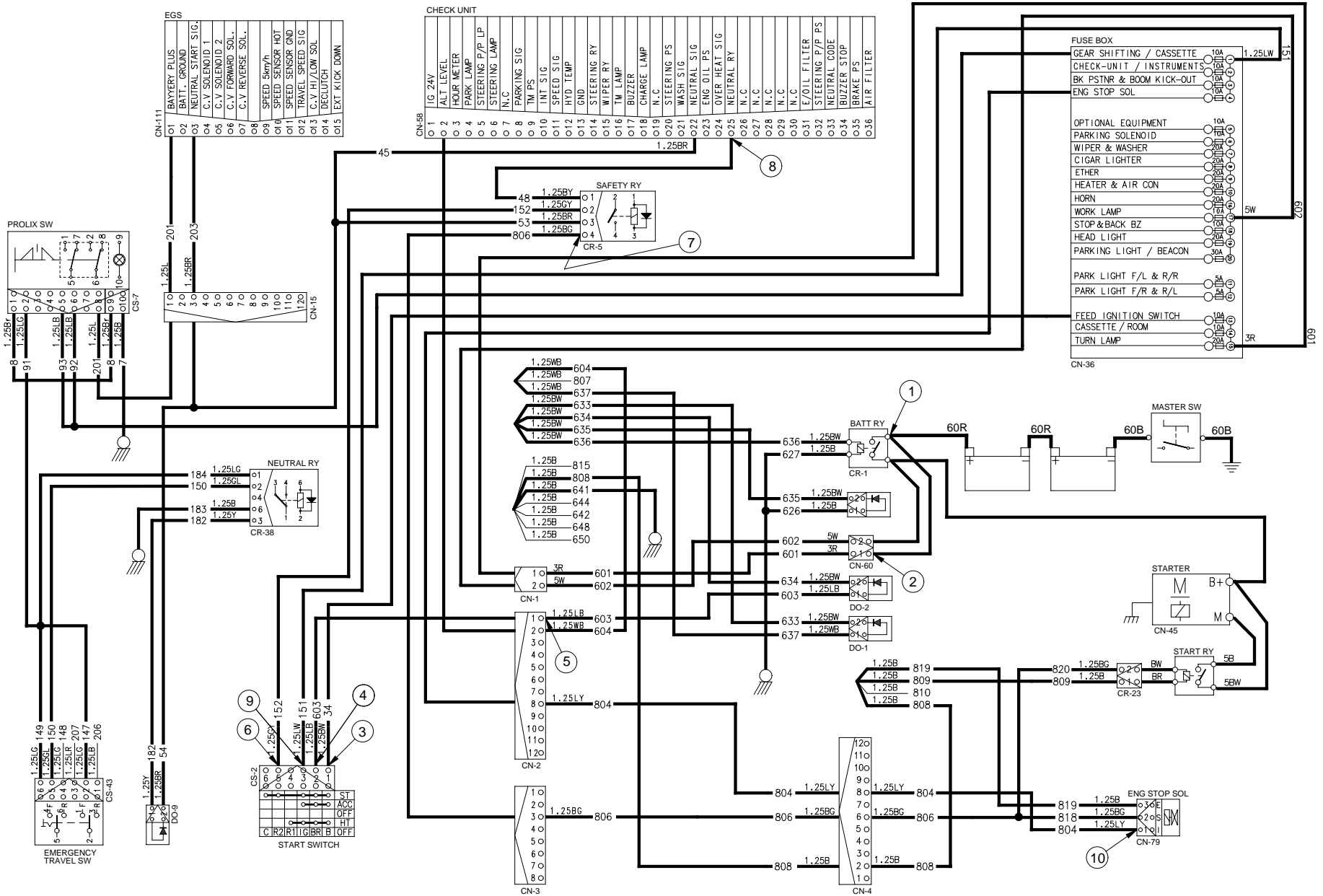

5. ENGINE STOP CIRCUIT

1) OPERATING FLOW

Start key OFF [CS-2(3)] → Fuse box (No.4) → I/conn [CN-2(8)] → I/conn [CN-4(8)]
→ Engine stop solenoid OFF [CN-79]

2) CHECK POINT

Engine	Key switch	Check point	Voltage
OFF	OFF	⑨ - GND (Start key IG terminal) ⑩ - GND (Engine stop solenoid)	0V

※ GND : Ground

3) WIRING DIAGRAM - See page 7-12.

6. CHARGING CIRCUIT

When the starter is activated and the engine is started, the operator releases the key switch to the ON position.

Charging current generated by operating alternator flows into the battery through the battery relay (CR-1).

The current also flows from alternator to each electrical component and controller through the fuse box.

1) OPERATING FLOW

(1) Warning flow

Alternator [CN-74(1)] → I/conn [CN-4(4)] → I/conn [CN-2(2)] → Check unit [CN-58(2)→(18)]
 → I/conn [CN-6(1)] → Cluster charge warning lamp ON [CL-46(1), Below 24V]
 → J1[(332)→(336)] → Volt meter [CN-104(B)]

(2) Charging flow

Alternator → Starter [CN-45(B*)] → Battery relay [CR-1]
 ↳ Battery(+) terminal → Charging
 ↳ I/conn [CN-60(1),(2)] → I/conn [CN-1(1),(2)] → Fuse box

2) CHECK POINT

Engine	Key switch	Check point	Voltage
Running	ON	① - GND (Battery) ② - GND (Battery relay) ③ - GND (ALT B) ④ - GND (ALT I) ⑤ - GND (Check unit) ⑥ - GND (Fuse box)	20~28V

Engine	Key switch	Check point	Resistance
Running	ON	⑦ - GND (Cluster)	∞ Ω

※ GND : Ground

CHARGING CIRCUIT

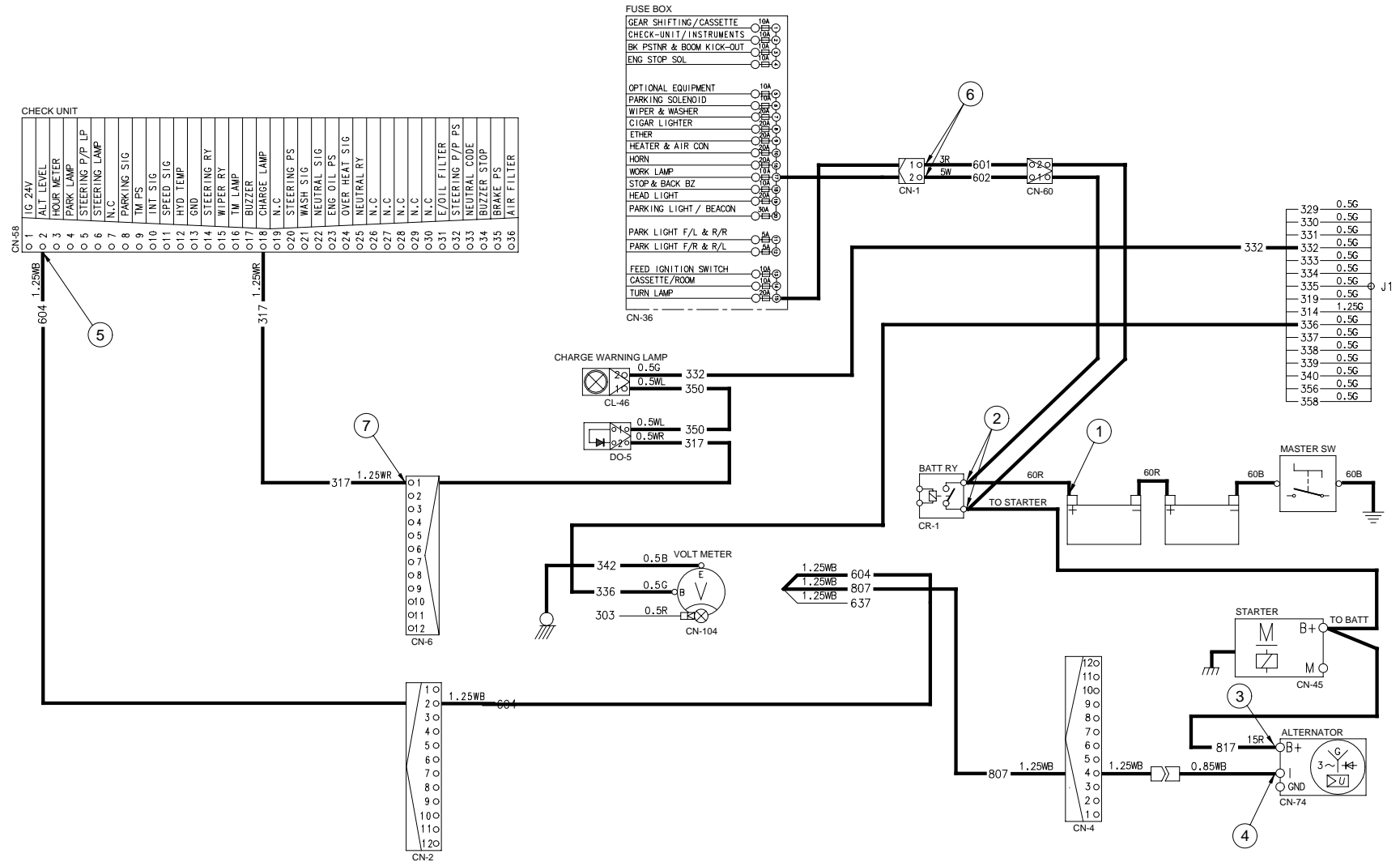

7. ELECTRIC PARKING, DECLUTCH CIRCUIT

1) OPERATING FLOW

(1) Parking OFF

Fuse box (No.6) → Parking switch OFF [CS-17(6)→(8)] → Parking solenoid ON(Activated)
 → Parking brake released(By hydraulic pressure)

(2) Parking ON

Fuse box (No.6) → Parking switch ON

- Parking solenoid [CN-71] OFF
 - Parking brake applied [By spring force]
- [CS-17(6)→(2)] → Parking switch indicator lamp ON
- [CS-17(5)→(1)] → I/conn [CN-15(4)]
 - EGS [CN-111(14)] → T/M declutch

(3) Declutch ON

Fuse box (No.6) → Clutch cut-off switch ON

- Clutch cut-off switch [CS-42(6)→(2)]
 - Clutch cut-off switch indicator lamp ON
- Clutch cut-off switch [CS-42(5)→(1)]
 - Service brake applied
 - Service brake pressure switch ON [CD-5]
 - I/conn [CN-15(4)] → Declutch
 - Clutch oil pressure switch

2) CHECK POINT

Engine	Key switch	Check point	Voltage
Running	ON	① - GND (Parking switch input) ② - GND (Parking switch output) ③ - GND (Parking switch input) ④ - GND (Parking switch output) ⑤ - GND (Parking solenoid) ⑥ - GND (Press switch clutch out-off) ⑦ - GND (Declutch input signal)	20~25V

※ GND : Ground

ELECTRIC PARKING, DECLUTCH CIRCUIT

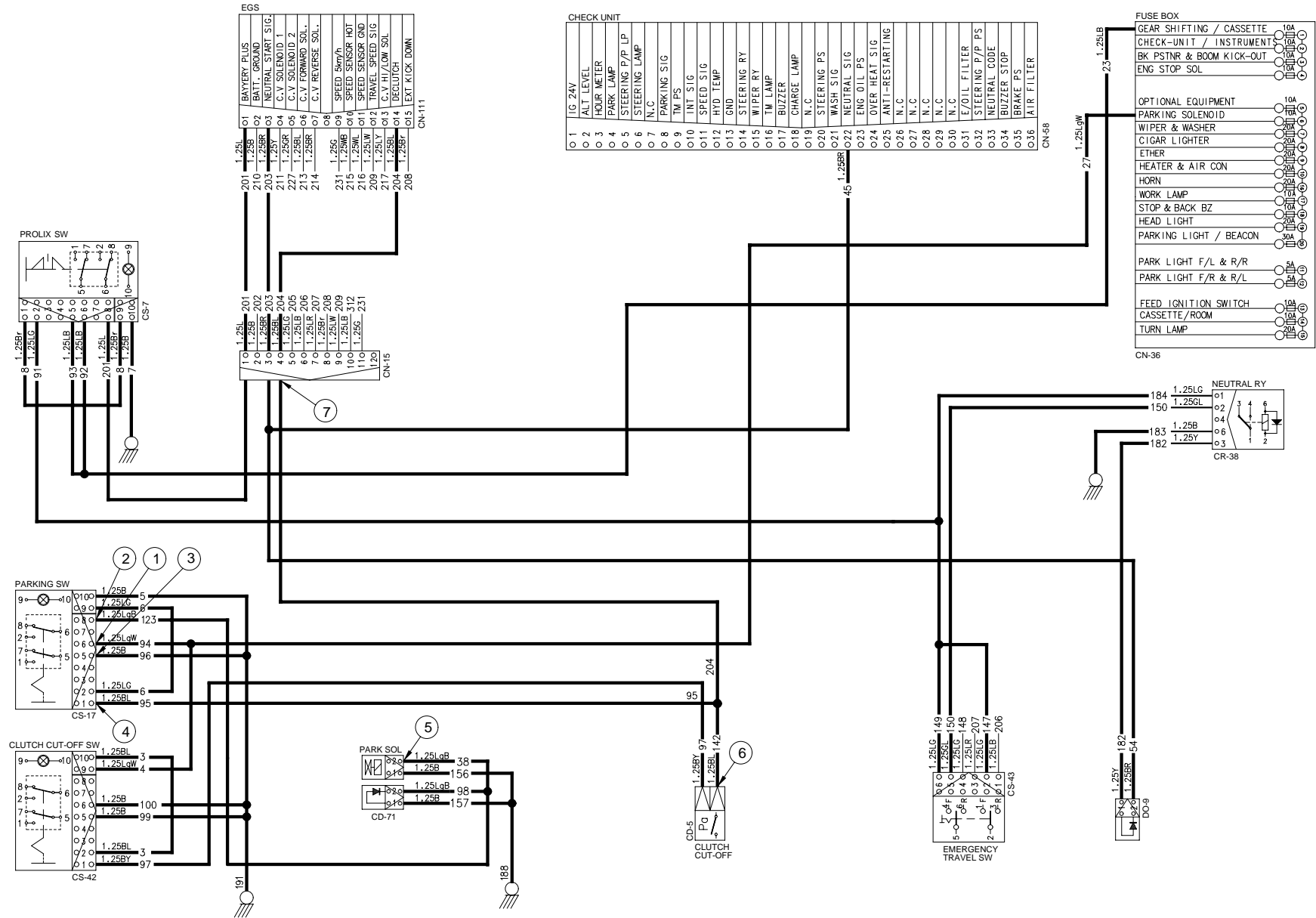

8. WIPER AND WASHER CIRCUIT

1) OPERATING FLOW

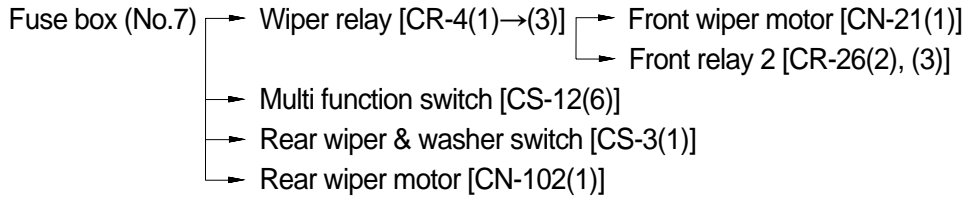

(1) Front washer switch ON

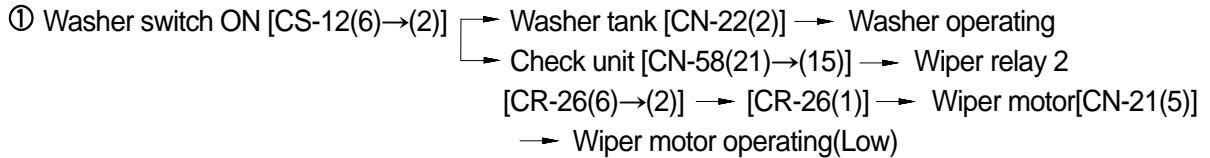

(2) Front wiper switch ON

① INT position

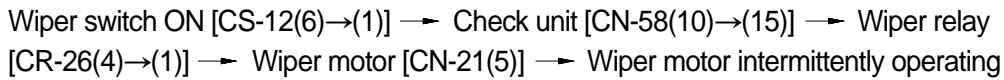

② Lo position

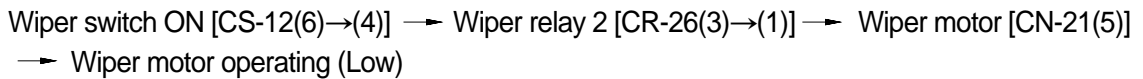

③ Hi position

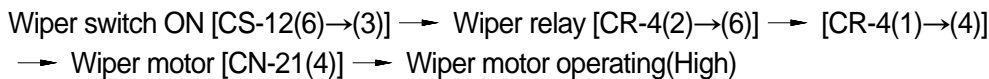

(3) Auto-parking (When switch OFF)

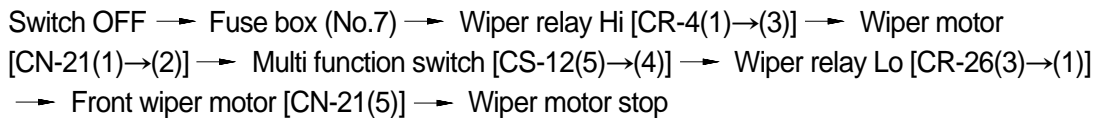

(4) Rear wiper and washer switch

① Wiper switch ON (1st step)

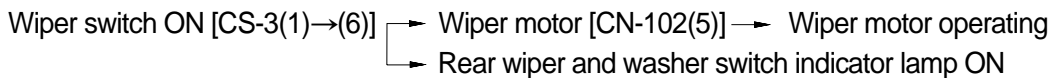

② Washer switch ON (2nd step)



2) CHECK POINT

Engine	Key switch	Check point	Voltage
Stop	ON	① - GND (Front wiper switch power input) ② - GND (Rear wiper switch power input) ③ - GND (Wiper relay power input) ④ - GND (Front wiper motor Lo power input) ⑤ - GND (Front wiper motor High power input) ⑥ - GND (Wiper relay power input) ⑦ - GND (Front washer power output) ⑧ - GND (Rear washer power output) ⑨ - GND (Front wiper motor power output) ⑩ - GND (Rear wiper motor power output)	20~25V

※ GND : Ground

WIPER AND WASHER CIRCUIT

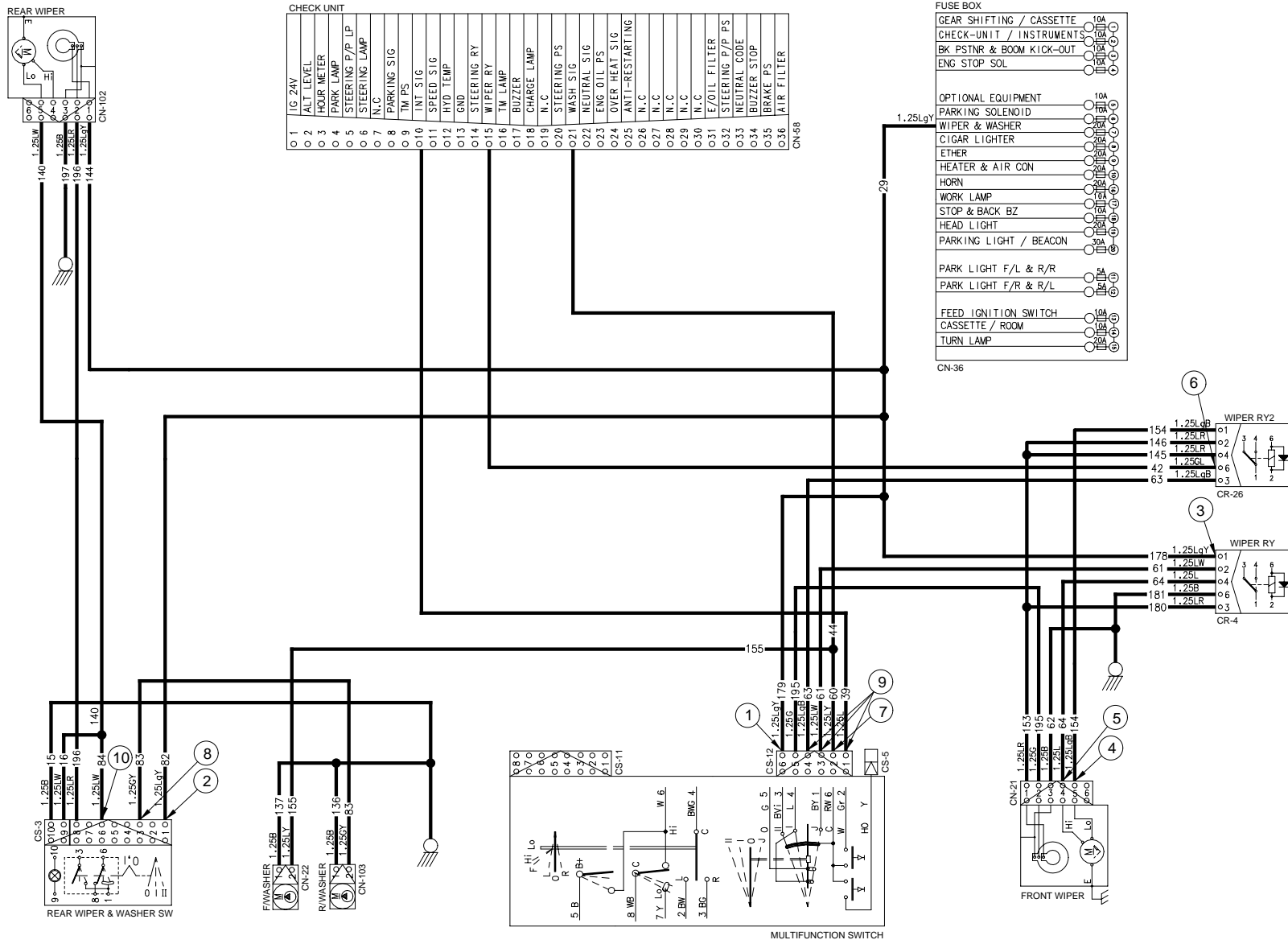

MONITORING CIRCUIT

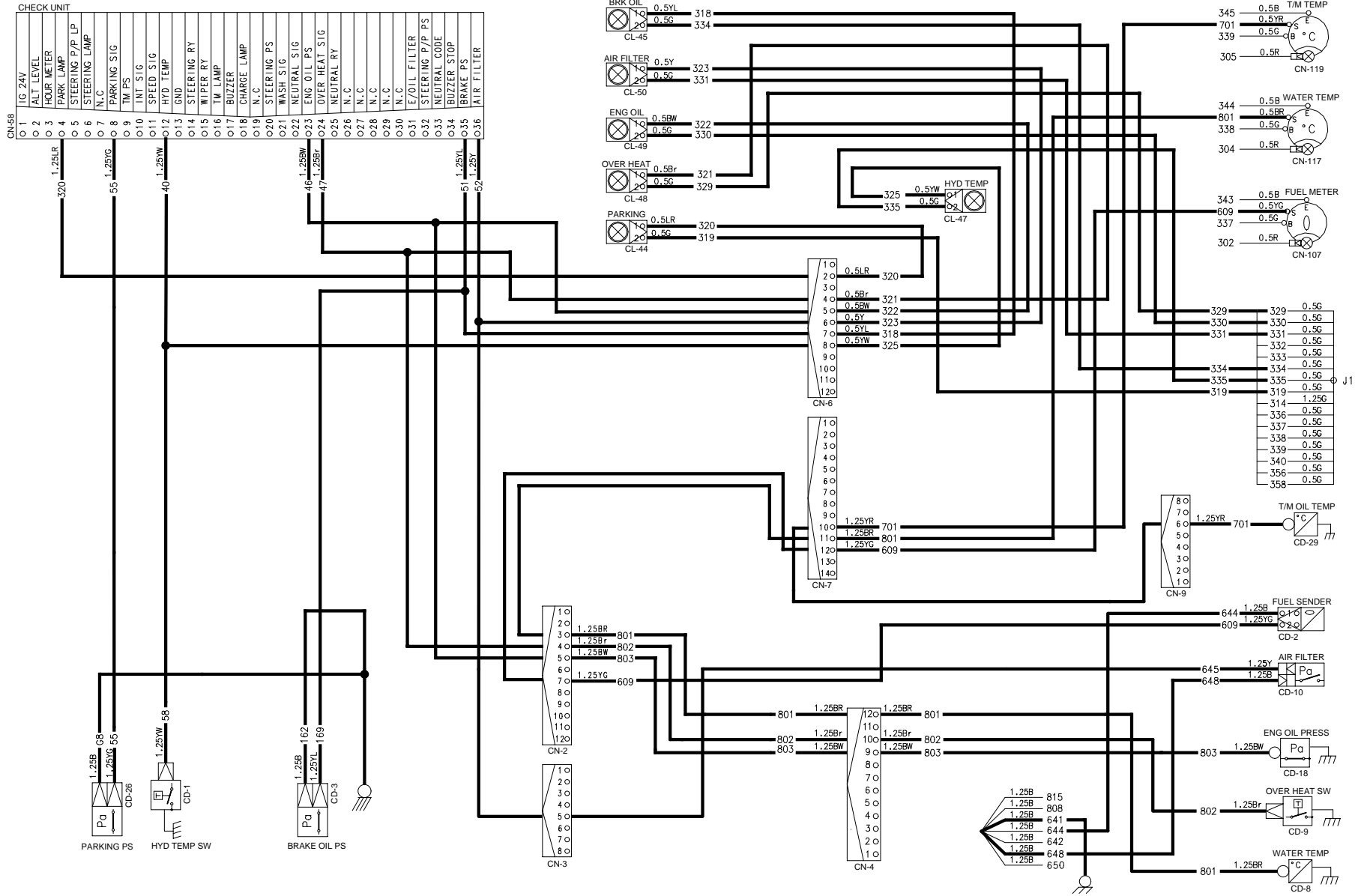

HAZARD, TURN AND ROTARY CIRCUIT

